

Installation, Operation and Maintenance Manual

Please read and save these instructions for future reference. Read carefully before attempting to assemble, install, operate or maintain the product described. Protect yourself and others by observing all safety information. Failure to comply with these instructions will result in voiding of the product warranty and may result in personal injury and/or property damage.

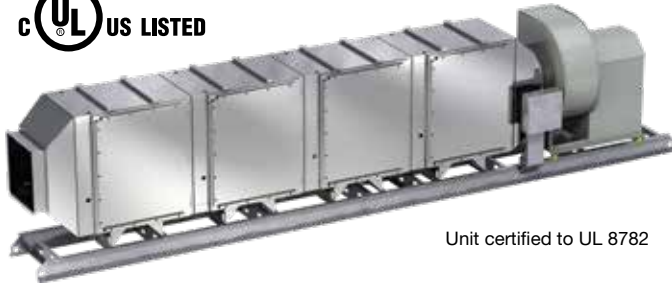

Unit certified to UL 8782

The Grease Trapper Pollution Control Unit is a pre-engineered mechanical filtration pollution control unit with integral exhaust fan (available without exhaust fan as an option). The unit is designed to remove grease and odor molecules from the kitchen exhaust airstream. This installation manual covers procedures for receiving, installing, and maintaining the filtered section of the unit.

For additional instructions and maintenance information on the integral exhaust fan, when applicable, refer to the fan nameplate to determine model type and visit greenheck.com to download the corresponding manual.

Table of Contents

Receiving, Unpacking, Handling, Storage	2
Grease Trapper System Function	3
System Components.	3
PCU Field Assembly	
Unit Modules.	4
Attaching Fan	5
Installation	
Rigging and Placing Equipment	6
Ductwork, Electrical & Plumbing Connections. .6-7	
Remote Filter Status Indicator Panel	7
Filter Installation	7
Fire System.	7
Operation	
Start-Up	8
Remote Filter Status Indicator	8
Filter Replacement	8
Carbon Tray Replacement	8
Maintenance	
Regular Scheduled Maintenance	9
Replacement Filter - Parts Ordering.	9
Unit Layout - Elevation Views.	10
Wiring Diagrams	11
Our Commitment.	12

General Safety Information

Only qualified personnel should install this system. Personnel should have a clear understanding of these instructions and should be aware of general safety precautions. Improper installation can result in electric shock, possible injury due to coming in contact with moving parts, as well as other potential hazards. Other considerations may be required if high winds or seismic activity are present. If more information is needed, contact a licensed professional engineer before moving forward.

- Follow all local electrical and safety codes, as well as the National Electrical Code (NEC), and the National Fire Protection Agency (NFPA), where applicable. Follow the Canadian Electric Code (CEC) in Canada.
- The rotation of the fan wheel is critical. It must be free to rotate without striking or rubbing any stationary objects.
- Fan motor must be securely and adequately grounded.
- Do not spin fan wheel faster than maximum cataloged fan rpm. Adjustments to fan speed significantly effects motor load. If the fan RPM is changed, the motor current should be checked to make sure it is not exceeding the motor nameplate amps.
- Do not allow the power cable to kink or come in contact with oil, grease, hot surfaces or chemicals. Replace cord immediately if damaged.
- Verify that the power source is compatible with the equipment.
- Never open access doors to a duct while the fan is running.

DANGER

Always disconnect power before working on or near a fan. Lock and tag the disconnect switch or breaker to prevent accidental power up.

CAUTION

When servicing the fan, motor may be hot enough to cause pain or injury. Allow motor to cool before servicing.

CAUTION

Precaution should be taken in explosive atmospheres.

Receiving

Upon receiving the product, check to make sure all items are accounted for by referencing items shown on the packing list. Inspect each crate for shipping damage before accepting delivery. Notify the carrier if any damage is noticed. The carrier will make a notation on the delivery receipt acknowledging any damage to the product. All damage should be noted on all the copies of the bill of lading which is countersigned by the delivering carrier. A Carrier Inspection Report should be filled out by the carrier upon arrival and filed with the Traffic Department. If damaged upon arrival, file claim with carrier. Any physical damage to the unit after acceptance is not the responsibility of manufacturer.

Unpacking

Verify that all required parts and the correct quantity of each item have been received. If any items are missing, report shortages to your local representative to arrange for obtaining missing parts. Sometimes it is not possible that all items for the unit be shipped together due to availability of transportation and truck space. Confirmation of shipment(s) must be limited to only items on the bill of lading. Remove all other shipping/packing materials including fan tie down straps.

Handling

Units are to be rigged and moved by the lifting brackets provided or by the skid when a forklift is used. Location of brackets varies by model and size. Handle in such a manner as to keep from scratching or chipping the coating. Damaged finish may reduce ability of unit to resist corrosion.

Storage

Units are protected against damage during shipment. If the unit cannot be installed and operated immediately, precautions need to be taken to prevent deterioration of the unit during storage. The user assumes responsibility of the unit and accessories while in storage. The manufacturer will not be responsible for damage during storage. These suggestions are provided solely as a convenience to the user.

INDOOR - The ideal environment for the storage of units and accessories is indoors, above grade, in a low humidity atmosphere which is sealed to prevent the entry of blowing dust, rain, or snow. Temperatures should be evenly maintained between 30°F (-1°C) and 110°F (43°C) (wide temperature swings may cause condensation and “sweating” of metal parts). All accessories must be stored indoors in a clean, dry atmosphere.

Remove any accumulations of dirt, water, ice, or snow and wipe dry before moving to indoor storage. To avoid “sweating” of metal parts allow cold parts to reach room temperature. To dry parts and packages, use a portable electric heater to get rid of any moisture buildup. Leave coverings loose to permit air circulation and to allow for periodic inspection.

OUTDOOR - Units designed for outdoor applications may be stored outdoors, if absolutely necessary. Roads or aisles for portable cranes and hauling equipment are needed.

The unit should be placed on a level surface to prevent water from leaking into it. The unit should be elevated on an adequate number of wooden blocks so that it is above water and snow levels and has enough blocking to prevent it from settling into soft ground. Locate parts far enough apart to permit air circulation, sunlight, and space for periodic inspection. To minimize water accumulation, place all unit parts on blocking supports so that rain water will run off.

Do not cover parts with plastic film or tarps as these cause condensation of moisture from the air passing through heating and cooling cycles.

Inspection and Maintenance during Storage

While in storage, inspect fans once per month. Keep a record of inspection and maintenance performed.

If moisture or dirt accumulations are found on parts, the source should be located and eliminated. At each inspection, rotate the fan wheel by hand ten to fifteen revolutions to distribute lubricant on motor. Every three months, the fan motor should be energized. Fans with special coatings may require special techniques for touch-up or repair.

Machined parts coated with rust preventive should be restored to good condition promptly if signs of rust occur. Immediately remove the original rust preventive coating with petroleum solvent and clean with lint-free cloths. Polish any remaining rust from surface with crocus cloth or fine emery paper and oil. Do not destroy the continuity of the surfaces. Wipe thoroughly clean with Tectyl® 506 (Ashland Inc.) or the equivalent. For hard to reach internal surfaces or for occasional use, consider using Tectyl® 511M Rust Preventive or WD-40® or the equivalent.

Removing from Storage

As units are removed from storage to be installed in their final location, they should be protected and maintained in a similar fashion, until the equipment goes into operation. Prior to installing the unit and system components, inspect the unit assembly to make sure it is in working order.

1. Check all fasteners, set screws on the fan, wheel, bearings, drive, motor base, and accessories for tightness.
2. Rotate the fan wheel(s), where applicable, by hand and assure no parts are rubbing.

Grease Trapper System Function

Grease Trapper is a 3-stage mechanical air filtration unit, with an additional carbon filter module. It is designed for two specific functions:

1. Remove grease particulate from kitchen exhaust.
2. Remove odor molecules from kitchen exhaust.

NOTE

- Grease Trapper must be connected to a listed exhaust hood assembly and must be installed in accordance with local building codes, NFPA 96 and NEC.
- The unit must be installed with a minimum 12 inch clearance to combustible materials on top of unit, and six inches on the sides and bottom.

Filter stages 1, 2 and 3 are mechanical air filters of progressive filtration efficiency that retain the grease particles.

Each filter stage is monitored by an individual pressure switch that signals when a particular filter stage needs replacing. The pressure switches are located inside the Pressure Switch Enclosure located by the fan. When a filter stage requires replacement, a signal from the pressure switch enclosure lights an indicator light located on the Remote Filter Status Indicator Panel. The remote status indicator must be field mounted in an area convenient for monitoring by the cook staff.

NOTE

Grease Trapper is designed to remove submicron, airborne particulate generated from cooking processes. This system is NOT INTENDED to eliminate regular hood and ductwork cleaning and service. Improper care and maintenance of this system and associated hoods and ductwork may present a fire hazard.

System Components

Unit Body

The unit body is shipped on a common mounting rail ready for installation. If the unit was ordered with an exhaust fan, the fan will also be mounted on the unit. If unit must be disassembled in the field, refer to instructions on page 4.

Filters

Filter quantity for each filter stage is based on unit size. A consistent quantity of filters is provided for each stage of filtration.

Filter Quantity				
Housing	Module 1 Metal Mesh	Module 2 MERV 8	Module 3 MERV 15	Module 4 Carbon Filters
30	3	3	3	6
45	4	4	4	10
60	6	6	6	14
90	8	8	8	20
120	12	12	12	28

Remote Filter Status Indicator Panel *(see page 7)*

At time of delivery, a remote status indicator panel is shipped loose. This item must be mounted remotely in the cooking area prior to unit start-up.

Fire Cabinet

The fire cabinet should be mounted as close to the Pollution Control Unit as possible, typically within 5 feet. Unless the fire cabinet was provided with an outdoor cabinet and heater, the cabinet should be mounted indoors and must be kept above freezing.

PCU Field Assembly - if applicable

If unit is shipped in sections, each section will **need to be assembled in the field.**

Unit Modules

1. Remove (4) 5/16 inch mechanical fasteners that attach each module to the rails.
2. Remove 5/16 inch mechanical fasteners that attach each module to the next adjacent module. PCU housing size can be found in the model number on tag on side of unit.

Housing Size	Number of Mechanical Fasteners
30, 45	4
60, 90	6

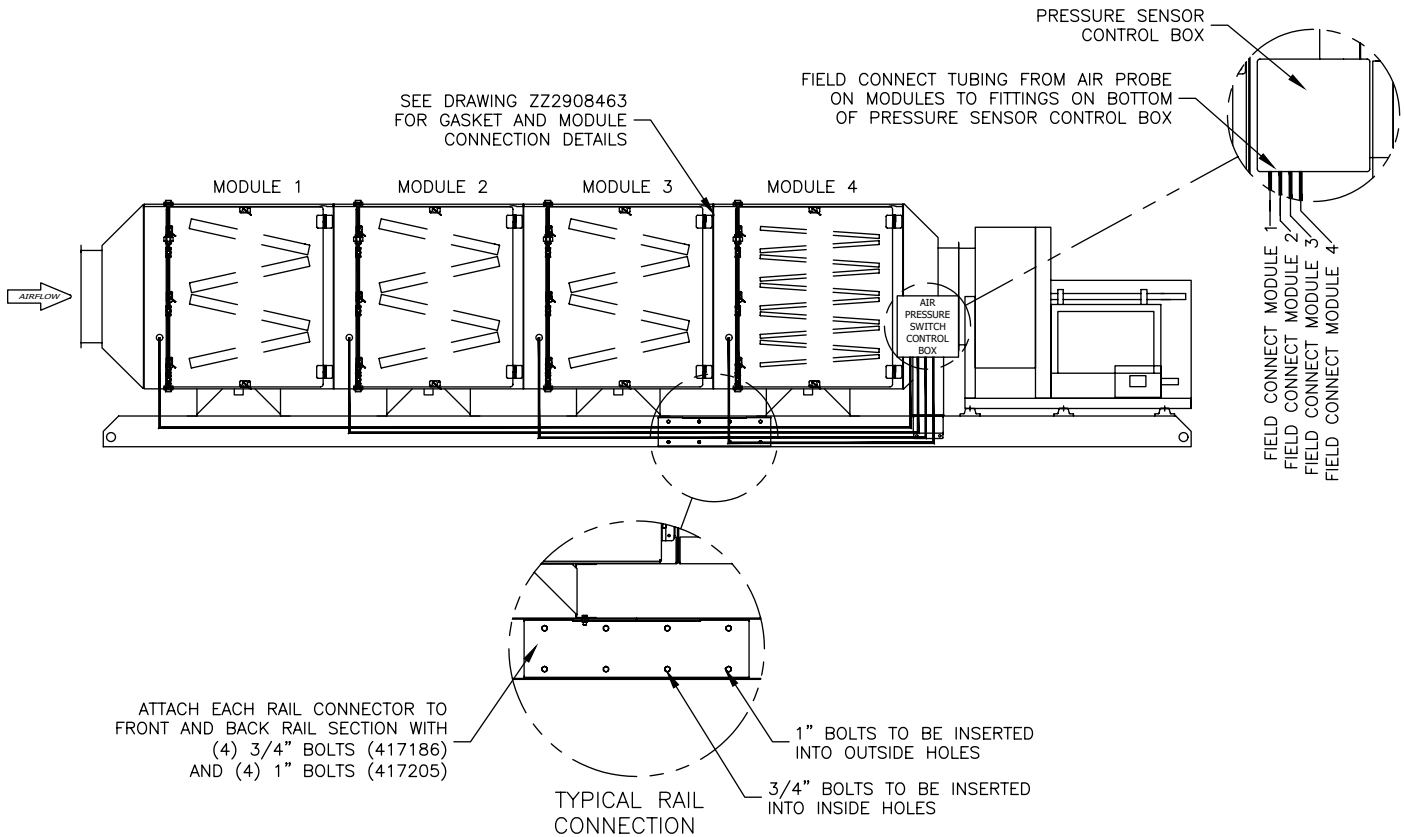

NOTE

Doors will have to be opened and/or removed to access fasteners inside of modules.

- After rails and modules have been moved to desired location, the modules and rails can be reassembled. Install gasket to applicable cells as shown below.

MODULE FLANGE
GASKETING DETAIL

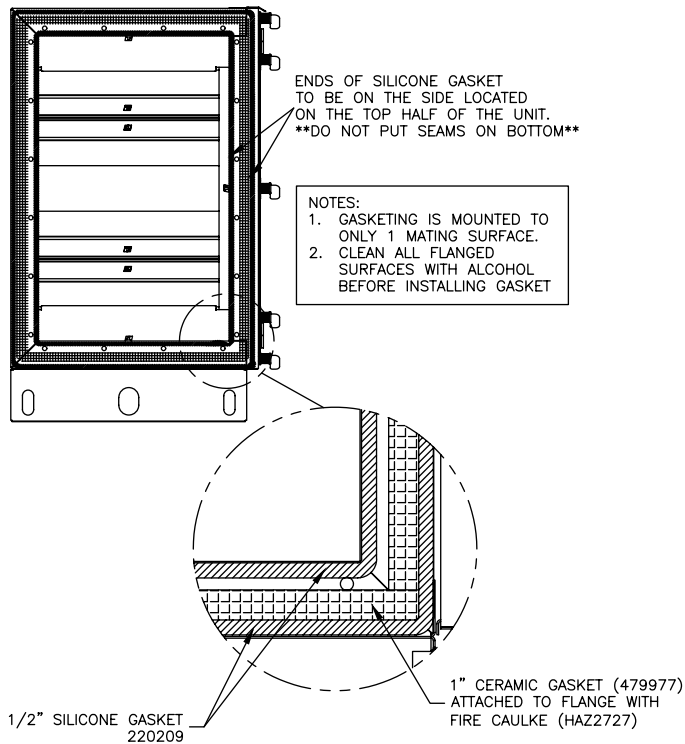

- Reattach the fasteners from step 2 as shown in the drawing below, ensuring proper gasket and seam cover installation.

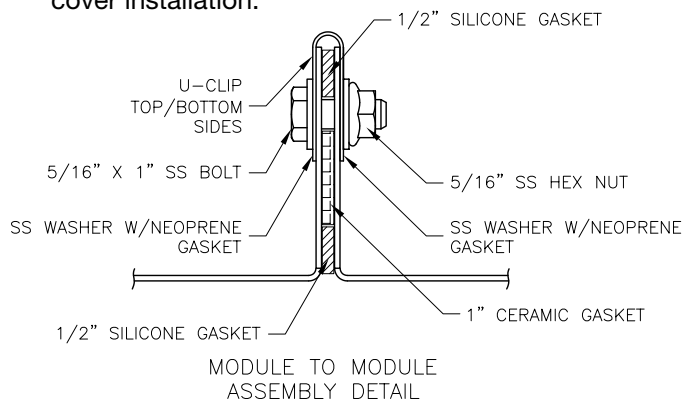

Attaching Fan

The PCU fan is shipped bolted to unit body and rails. If the unit was requested to be disassembled in the field, the unit body-to-fan connection has not been sealed.

- To disassemble in the field, remove mechanical fasteners that attach the companion flange and fan to the unit body.
- Remove mechanical fasteners that attach the fan to the isolators on the rails.

After fan and unit body have been moved to desired location, the fan can be sealed and reattached to the unit body and rails.

- To seal the fan to unit body connection, apply fire rated caulk (3M Fire Barrier Sealant CP25WP+ or equivalent) to fan inlet flange. Make sure to apply caulk around each bolt hole. Caulk to be located outside of silicon gasket mounted during step 4.

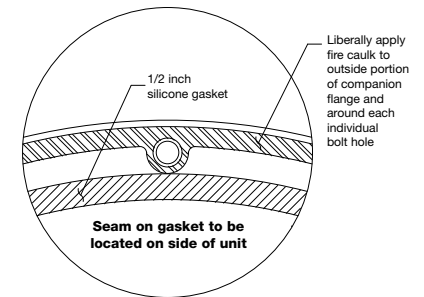

- Attach 1/2 inch silicone gasket around fan inlet flange. Silicone gasket to be located inside of caulk applied in step 3 (seam of gasket to be located on the side of unit).

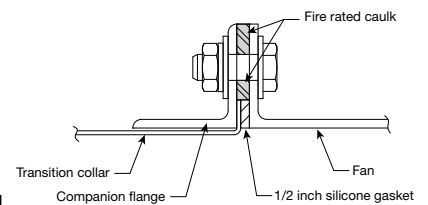

- Attach 1/2 inch silicone gasket around fan inlet flange. Silicone gasket to be located inside of caulk applied in step 3 (seam of gasket to be located on the side of unit).
- To reassemble locate fan on isolators on rails.
- Reattach fasteners for companion flange removed in step 1.
- Reattach fasteners attaching fan to isolators removed in step 2.

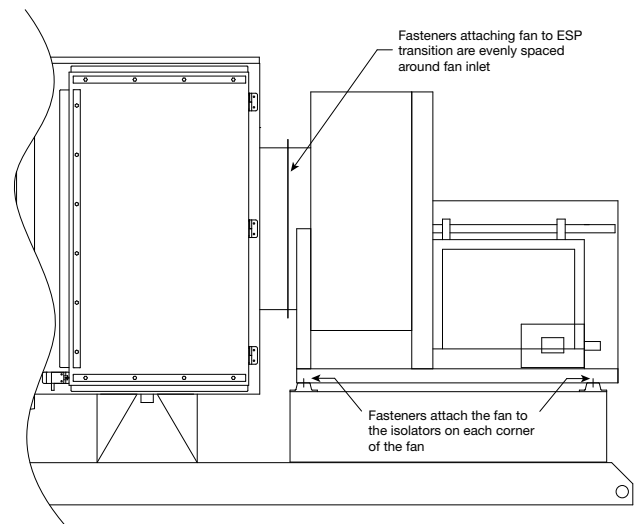

Installation

Rigging and Placing Equipment

1. The unit is furnished with lifting lugs at the four corners.
2. Use a crane and a set of spreader bars hooked to all four factory lifting lugs to lift the unit.

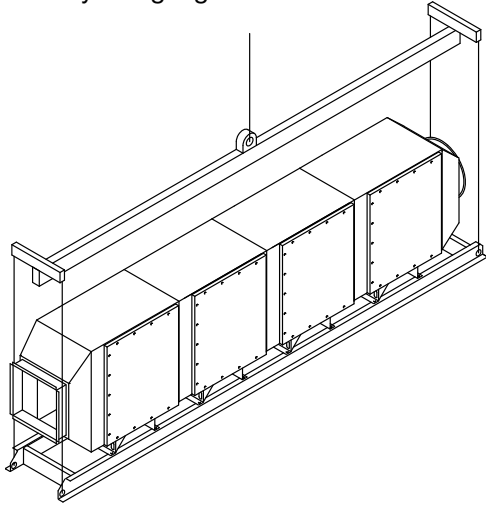

3. Field weight will vary depending upon final selections such as fan type, accessories, etc. Approximate weights (4 module unit with mounted utility set fan as basis) are shown in the table.

Housing	Approximate Weight	
	lbs	kg
30	1285	583
45	1582	718
60	2002	908
90	2531	1148
120	3035	1377

4. The unit can be positioned on a base or roof deck suitable for this purpose.
5. The unit must be anchored to its base/roof deck.

6. Alternatively, the unit may be suspended from an adequate overhead structure, using suitable undercarriage or hanging rods (by others). If the unit is suspended by hanging rods, minimum 1/2 inch (12.7 mm) diameter threaded rod is to be used. All hanger brackets/lifting lugs must be used to ensure proper support of the unit. The unit must also be hung level to ensure proper operation.
7. A service clearance of 36 inches must be provided on the access door side of the unit.

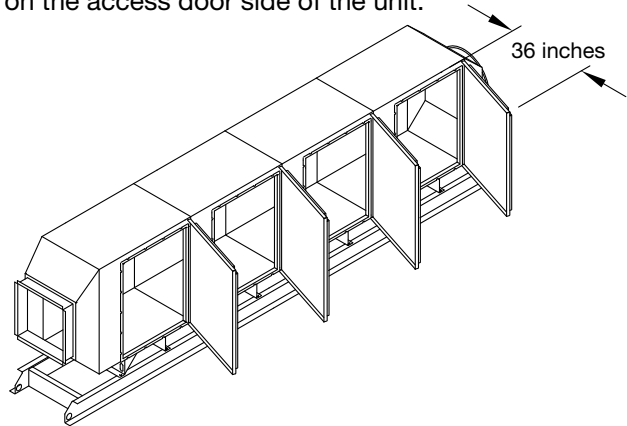

8. A minimum 12 inch clearance must be maintained between the top and 6 inches on each side and bottom of this unit and any combustible material.
 - Ensure the fan is located in an easily accessible area, of adequate size and clearance to allow for service or removal.
9. The Remote Filter Status Indicator Panel (see page 5 and 7) should be located in an area convenient for monitoring by the cook staff. For details on wiring this item, refer to the Wiring Diagrams on page 7.

Ductwork Connections

Ductwork must conform to the IMC and SMACNA guidelines.

All factory-built grease duct needs to be constructed in accordance with ANSI/UL 1978 and should be manufactured and installed in accordance with their listing. All field-built grease ductwork must be constructed in the following manner per NFPA 96, unless otherwise specified by the local authority having jurisdiction (AHJ):

Materials - Ducts shall be constructed of and supported by carbon steel not less than 1.37 mm (0.054 in.) (No. 16 MSG) in thickness or stainless steel not less than 1.09 mm (0.043 in.) (No. 18 MSG) in thickness.

Installation - All seams, joints, penetrations, and duct to hood collar connections shall have a liquid-tight external weld.

Units intended for indoor mounting have an outlet mounting flange provided on the outlet of the fan. Outlet ductwork from the exhaust fan is required to be per the above mentioned methods unless otherwise specified by the local authority having jurisdiction (AHJ).

Electrical Connections

Electrical wiring must conform to the equipment data plate information and to the NEC and local code requirements.

Motor - This unit is furnished with an ON/OFF disconnect switch mounted adjacent to the fan and factory-wired to the fan motor.

A 3-phase electrical supply must be field wired to the motor starter and from the motor starter to the ON/OFF disconnect switch.

Refer to the wiring diagram provided in applicable control system for detailed instructions on wiring the fan. (See page 10 for more information).

Plumbing Connections

Each module is provided with a drain to allow any grease or washing solution to be removed from the unit. The drains must be connected to a grease receptacle ensure proper unit operation.

The units are provided with a 1-inch nipple from the factory located in the middle of each module to be used as a drain connection. The drains can be manifolded together and a ball valve is recommended on each module drain. All plumbing components are provided by others and must be installed based on local plumbing codes.

Remote Filter Status Indicator Panel

A single phase electrical supply must be field wired to the pressure switch enclosures located by the fan. For wiring details, refer to the diagram on page 10.

Filter Installation (see Figure #2 on page 9)

The first three stages of filter are shipped in the unit (Metal Mesh, Standard Pleated, High Efficiency). The final stage of filters (Carbon Trays) ship loose, and are typically located on the end of the shipping pallet.

Care must be taken to ensure filters are installed in the proper sequence and proper direction of airflow.

Open the access doors. Slide filters into filter racks in stages 1, 2, 3 and 4. Close and secure access doors.

Filter Stage	Description	Nominal Dimensions (inches)
Stage 1	MERV 2 Metal mesh frame filter	24 x 24 x 2
Stage 2	MERV 8 Standard pleated filter	24 x 24 x 2
Stage 3	MERV 15 High efficiency pleated filter	24 x 24 x 2
Stage 4	Pre-Filled Carbon Trays	24 x 24 x 1

NOTE

No high voltage wiring is run to the filtered sections of the unit. Wiring connections are made at the fan and the pressure switch enclosure located by the fan.

Fire System

The Pollution Control Unit (PCU) is furnished with factory pre-piped fire suppression nozzles. Field connection, tanks, controls, fusible link detectors, and commissioning is provided and installed, based on specifications at time of order. The AHJ may require additional protection.

The PCU may be provided with one or more cabinets, shipped loose for field install, containing the fire suppression components. If a fire cabinet(s) are provided, locate an area as close to the PCU as possible (within 5 feet from the PCU), with enough space to mount the fire cabinet(s), and fasten to wall. If provided with indoor cabinet(s), fasten to wall using 1/4" holes located along all four sides of the back wall of the cabinet. If provided with outdoor (NEMA4) cabinet(s), fasten to wall using 5/16" bolts at the four (4) holes located 3/4" offset from the corners of the back face of each cabinet. Size and type of fastener are the responsibility of installer. Ensure 36" of horizontal clearance in front of the cabinet(s) for access and code compliance. Ensure sufficient clearance above cabinet(s) for fire system piping to the PCU. Cabinet(s) may be provided with heater if mounted outdoors, refer to Fire System Cabinet Wiring Outdoor for details. Cabinet dimensions and quantity will vary based on the PCU size and mounting location (Indoor/Outdoor); see image and table for reference. Refer to unit fire drawings for final cabinet dimension and quantity.

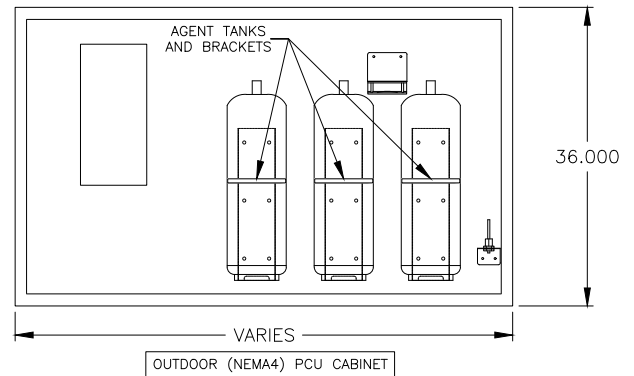
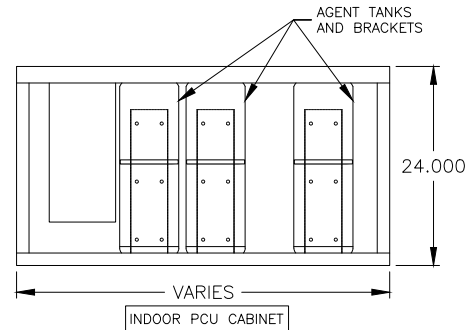

PCU Fire Cabinet Quantity and Size		
Housing Size	Indoor Cabinet	Outdoor (NEMA4) Cabinet
30	See Drawings	(1) 42"
45	See Drawings	(1) 60"
60	See Drawings	(1) 60"
90	See Drawings	(1) 60"

ANSUL

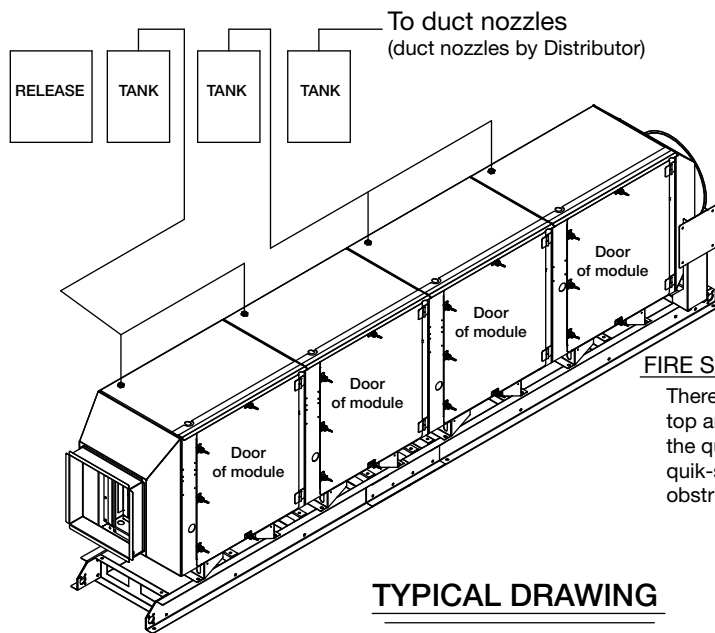

FIRE SYSTEM DISTRIBUTOR / FIRE SYSTEM INSTALLER:

There are four quik-seals on each module. Two are on the top and two are on the bottom. Connection to only one of the quik-seals on each module is required. Multiple quik-seals are provided for situations where there are obstructions to the connection point.

TYPICAL DRAWING

- Do not install fire piping in front of doors on module. Must have 36 inches of clearance.
- Do not install fire piping such that it interferes with the drain plugs & piping on the bottom of the modules.

Operation

NOTE

Prior to starting the fan, remove fan tie down straps. These are used only to prevent shipping damage. After removing the tie down straps, the fan should float freely on the isolators. Confirm that the installation is completed as shown in the Installation section.

IMPORTANT

Replace filters immediately after the Filter Status Indicator light comes on. Failure to do so may cause a reduced exhaust air volume allowing smoke to escape into the kitchen, or may cause filters to rupture, or both. The terminal resistance for each stage of filters is factory set. Altering these settings without first contacting Greenheck will void the manufacturer's warranty.

Start-Up

Turn the unit on momentarily and then turn off. Remove fan drive access cover and verify proper fan wheel rotation. If rotation is backwards, reverse the fan motor electrical input leads. After verifying proper fan wheel rotation, the unit is ready for operation.

Remote Filter Status Indicator

As filter stages 1, 2 and 3 load with grease particles, resistance to airflow increases and the exhaust air volume decreases. Pressure switches continuously read the resistance across each

Filter Stage	Resistance Setting
1	0.5 in. wg.
2	
3	

filter stage. Each pressure switch is factory preset to transmit an alarm signal when that stage of filter has reached its terminal resistance and needs replacing with new filters. This terminal resistance setting is based on the filter manufacturers rating. The alarm signal lights an indicator located on the face panel of the Remote Filter Status Indicator Panel.



Filter Replacement

Determine which stage(s) of filter needs replacing as shown by lighted indicator located on the face panel of the Remote Filter Status Indicator Panel.

1. Have the correct type and quantity of filters available at the unit.
2. Turn off and lockout power to the fan.
3. Open the appropriate access door(s).
4. Remove the spent filter(s) by sliding them out of the housing access door opening.
5. Replace with the proper new filter(s) making sure direction of airflow is correct.
6. Close and secure access door(s).
7. Turn on power to the fan.
8. Proper filter disposal is important to the environment. Refer to local landfill codes.

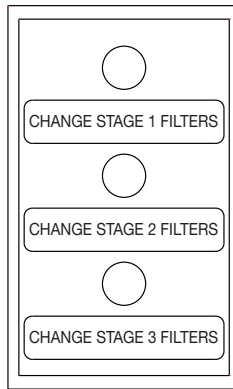

**Remote
Filter Status
Indicator Panel**

Carbon Tray Replacement

Unlike particulate filters, technology has yet to develop a cost-friendly method of determining when the carbon trays need replacing. So, the industry standard is the human sniff test. As the carbon begins to lose its effectiveness, odor breakthrough gradually occurs and odor concentration increases. Based on a variety of cooking applications/installations, life of the carbon trays can range from a few months to one year. Replace carbon trays when odor breakthrough is first noticed. When replacing carbon trays, follow the instructions in the Operation section, Filter Replacement, Steps 2 thru 8.

Maintenance

Regular Scheduled Maintenance

1. Replace stage 1, 2 and 3 filter(s) immediately after the Remote Filter Status Indicator lights up.
2. Replace carbon trays at the first sign of odor breakthrough.
3. Remove all filters and carbon trays and pressure wash/clean the housing interior as needed or as dictated by local code. Only use degreasers that are compatible with stainless steel surfaces. Use caution so as to not damage static pressure tips, tubing or fire system nozzles and detectors. Verify drain connections on unit. Dry the housing interior and replace Stage 1 thru 4 filters, close and secure access doors.
4. Remove/open fan scroll access door and pressure wash/clean all internal surfaces of the fan every 6 months. Check sheave-belt alignment and belt tightness.
5. Refer to fan Installation, Operation and Maintenance (IOM) manual provided with unit for maintenance requirements.

Replacement Filter - Parts Ordering

Replacement filters and carbon panels can be obtained through the Greenheck Parts Department, 800-355-5354 or your local authorized Greenheck Sales Representative. To locate your local Greenheck Representative, visit greenheck.com

Filter Stage	Description	Part Number
Stage 1	MERV 2 Metal mesh frame filter	479981
Stage 2	MERV 8 Standard pleated filter	1009615
Stage 3	MERV 15 High efficiency pleated filter	479980
Stage 4	Pre-Filled Carbon Trays	484411

Unit Layout - Elevation Views

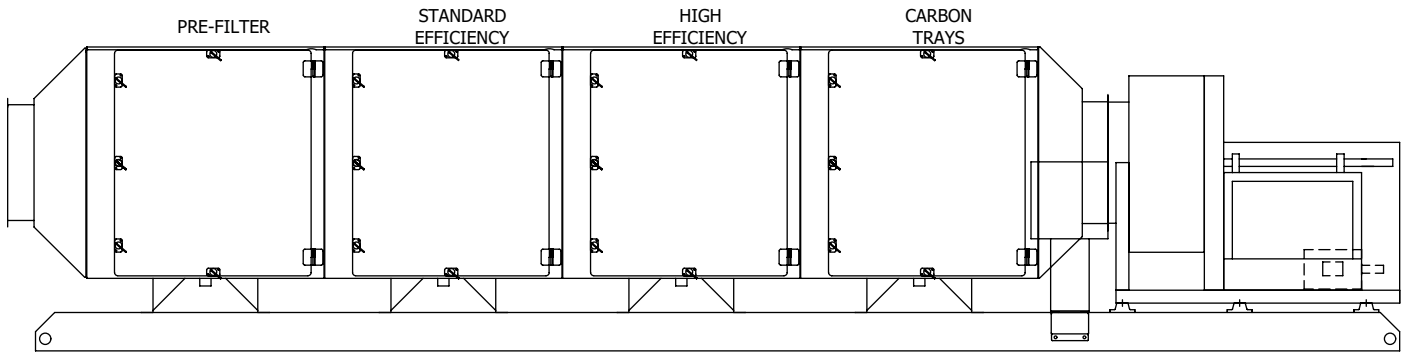

FIGURE #1: ACCESS DOOR SIDE

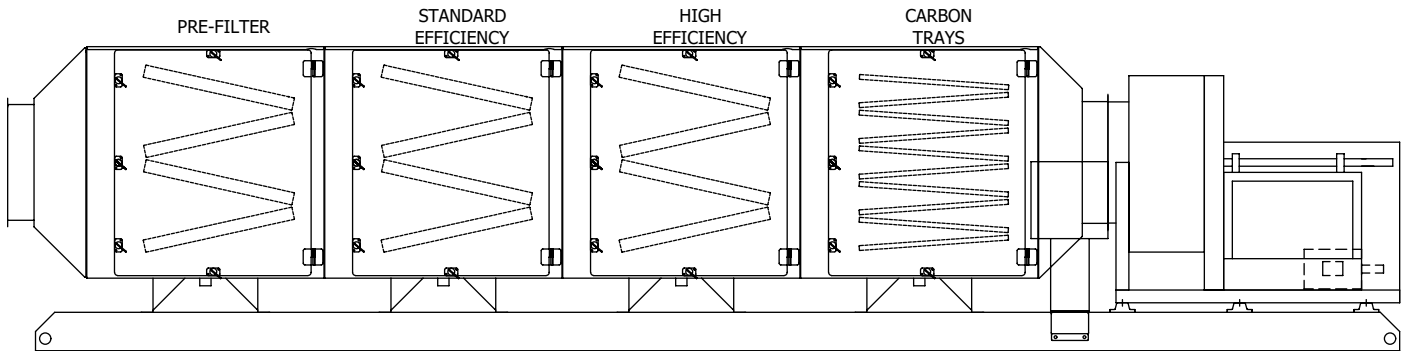

FIGURE #2: ACCESS DOORS REMOVED

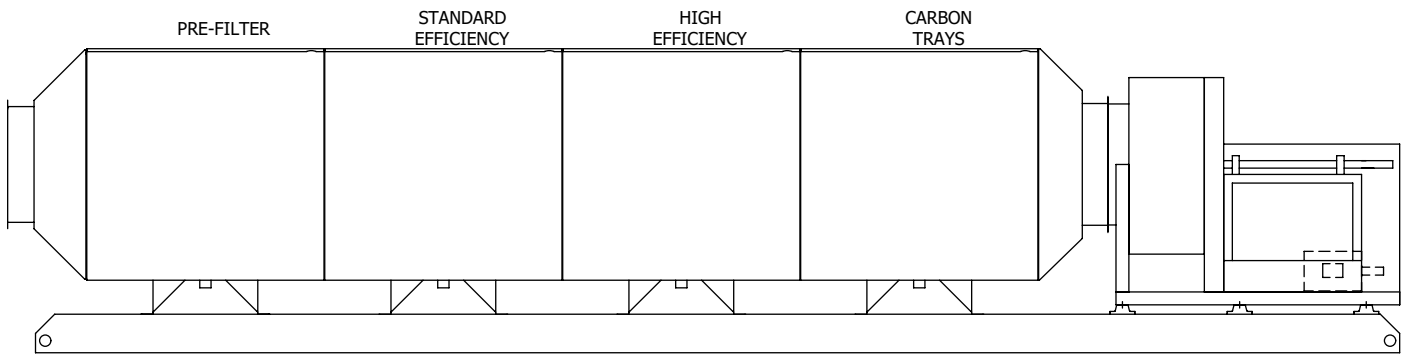
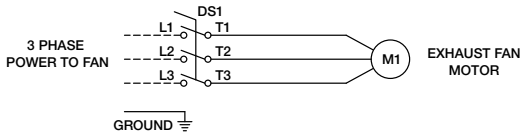

FIGURE #3: VIEW OF A NON ACCESS DOOR SIDE

Wiring Diagrams

FAN WIRING



FIRE SYSTEM WIRING - ANSUL ELECTRIC RELEASE

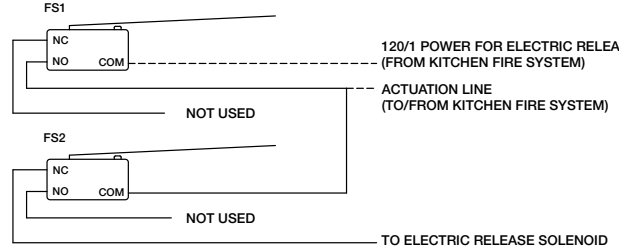

FIRE SYSTEM CABINET WIRING OUTDOOR

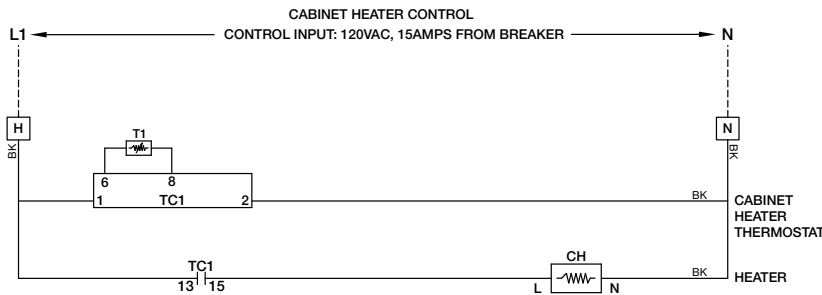

THERMOSTAT PROGRAMMING INSTRUCTIONS		
IR33 PARAMETER	SETTING	
c0	2	
P1	5.0	
P3	0	
c9	5	
c10	1	
c11	4	
c13	3	
P14	0	
c18	1	
c19	0	
St1	40	
THERMOSTAT SETPOINT ADJUSTMENT		
1. PRESS THE SET BUTTON TO SEE THE SETPOINT (St1).		
2. PRESS THE UP/DOWN ARROW BUTTON TO CHANGE THE SET POINT.		
3. PRESS THE SET BUTTON TO VIEW THE CURRENT TEMPERATURE.		
TORQUE:	FIELD WIRING:	
TERMINAL BLOCKS = 8 LB.IN	USE MINIMUM	
GROUNDING BLOCKS = 8 LB.IN	60° Copper Wire	
<p>————— FACTORY WIRING</p> <p>----- FIELD WIRING</p>		
LABEL	DESCRIPTION	WIRE COLOR
TC1	IR33 Controller	BK - black
T1	PT1000 Temperature Sensor	BL - blue
VFD	Variable Frequency Drive	BR - brown
CH	Cabinet Heater (250 Watts)	OR - orange
DS1	Disconnect	PR - purple
PS#	Pressure Switch	RD - red
LT#	Status Light	YW - yellow
FS1	Fire System Microswitch 1	WH - white
FS2	Fire System Microswitch 2	

FILTER STATUS WIRING

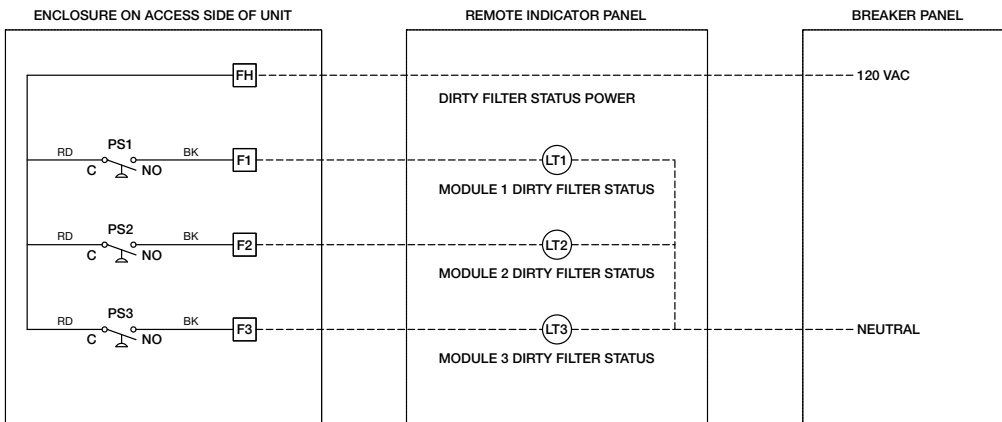

Our Commitment

As a result of our commitment to continuous improvement, Greenheck reserves the right to change specifications without notice.

Product warranties can be found online at Greenheck.com, either on the specific product page or in the literature section of the website at Greenheck.com/Resources/Library/Literature.

Greenheck Grease Trapper catalog provides additional information describing the equipment, fan performance, available accessories, and specification data.

AMCA Publication 410-96, Safety Practices for Users and Installers of Industrial and Commercial Fans, provides additional safety information. This publication can be obtained from AMCA International, Inc. at www.amca.org.

