



INSTALLATION MANUAL

FlexFusion® PLATINUM ELECTRIC COMBI

FPE-615

FPE-621

FPE-115

FPE-121

FPE-215

FPE-221



Directory of Contents

1	Introduction	4
1.1	About this manual	4
1.1.1	Explanation of signs	4
1.2	Use of the unit	6
1.3	Warranty	6
2	Safety information	7
3	Description of the unit	9
3.1	Overview of the unit	9
3.2	Planning drawing	11
3.3	Equipment and connection data	12
4	Transporting the unit	14
4.1	Information about transporting	14
4.2	Transporting to the installation site	14
4.2.1	Transporting on a pallet	15
4.2.2	Transporting without a pallet	15
4.2.3	Transporting by lifting and lowering	17
4.3	Unpacking the unit	17
5	Setting up the unit	18
5.1	Lifting the unit off the pallet	18
5.2	Setting up the unit on the equipment legs	19
5.3	Setting up the unit on a work surface	19
5.4	Aligning the unit	20
5.4.1	Aligning countertop units	21
5.4.2	Aligning floor-standing units	21

5.5	Minimum clearances	22
6	Connecting the unit	24
6.1	Opening and closing the housing	24
6.1.1	Removing and attaching the side panel	24
6.2	Making the electrical connection	26
6.2.1	Connected loads for various connection voltages	26
6.2.2	Connecting to the electric mains	27
6.2.3	Connecting the electric power cable to the unit	28
6.3	Connecting the power optimizing system	30
6.4	Connecting the unit to the network	30
6.5	Basic settings	32
6.6	Making the water connection	34
6.6.1	Information about the water connection	34
6.6.2	Connecting hard and soft water	34
6.6.3	Connecting soft water twice	36
6.7	Making the wastewater connection	37
6.7.1	Information about the wastewater connection	37
6.7.2	Connecting the wastewater line permanently	37
6.8	Making the exhaust air connection	38
6.8.1	Information about the exhaust air connection	38
7	Putting the unit into service	39
7.1	Filling out the commissioning report	39

1 Introduction

1.1 About this manual

Target group

The target group for the installation manual is trained technical personnel that is familiar with installing and operating the unit.

Figures

All figures in this manual are intended as examples. Discrepancies between these and the actual unit can arise.

The instruction manual is part of the unit and contains information on safe installation of the unit.

Observe and adhere to the following instructions:

- Read the instruction manual in its entirety prior to installation.
- Make the instruction manual available to the installer at the operating site at all times.
- Preserve the installation manual throughout the service life of the unit.
- Insert any supplements from the manufacturer.
- Pass on the installation manual to any subsequent operator of the unit.

1.1.1 Explanation of signs

	<div style="background-color: red; color: white; padding: 5px;"> DANGER</div> <p>Imminent threat of danger Failure to comply will lead to death or very severe injuries.</p>
	<div style="background-color: orange; color: white; padding: 5px;"> WARNING</div> <p>Possible threat of danger Failure to comply can lead to death or very severe injuries.</p>
	<div style="background-color: yellow; color: black; padding: 5px;"> CAUTION</div> <p>Dangerous situation Failure to comply can cause minor or moderate injuries.</p>





	SAFETY INSTRUCTIONS
	<p>Material damage Failure to comply can cause material damage.</p>

	<i>NOTICE</i>
	<p>Information Notes for better understanding and operation of the unit.</p>

Symbol / sign	Meaning
▪	Listing of information.
	Action steps, which can be performed in any sequence.
1. 2.	Action steps, which must be performed in the prescribed sequence.
	Result of a listed action.

1.2 Use of the unit

This unit is intended to be used solely for commercial purposes, particularly in commercial kitchens.

This unit is certified in the following:    

1.3 Warranty

The warranty is void and safety is no longer assured in the event of:

- Modifications or technical changes to the unit,
- Improper use,
- Incorrect startup, operation or maintenance of the unit,
- Problems resulting from failure to observe these instructions.

2 Safety information

Ensuring conformity with standards

Observe applicable international, European and national laws, regulations, standards and directives for the unit when transporting, setting up and connecting it.

Improper installation

Risk of property damage and personal injury from improper installation

- Install the unit only as specified in these installation instructions.
- Use only original spare parts.

Fire prevention

Risk of fire from combustible surfaces

- Observe general fire prevention regulations.

Organisational measures

Risk of property damage and personal injury from lack of organizational measures

- Identify hazard areas when transporting, setting up and connecting the unit.
- Prior to starting the installation work, notify any operators present about the procedure.
- Prior to starting the installation work, discuss how to behave in an emergency.
- Use equipment and protective gear suitable for the activity.
- Brace housing components to prevent them from falling over and dropping.

Transportation and storage

Risk of personal injury and property damage from improper transportation and improper storage.

- Store the unit in a dry, frost-free environment.
- Observe the safety regulations for the lifting gear used.
- Attach the unit to the lifting gear securely during transport and setup, and prevent it from dropping.
- Transport the unit in an upright position, do not tilt or stack.
- Pay attention to protruding parts when transporting the unit without packaging.

Setup**Risk of property damage and personal injury from improper setup**

- Ensure that the installation area has adequate load-bearing capacity.
- Where safety shoes and protective gloves.

Electrical connection**Risk of fire from improper connection**

- Observe applicable regional regulations of the electrical utility.
- Ensure that only licensed electricians connect the unit.
- Ensure that the electrical system is earthed by a protective earthing conductor.
- Note the information on the nameplate.

Risk of electric shock from live components.

- Prior to working on the electrical system, switch off the unit, disconnect the electrical system from the mains and prevent power from being switched on again. Check to ensure absence of voltage.

Commissioning**Risk of property damage and personal injury from improper commissioning**

- Read the operating instructions prior to commissioning. Observe the safety instructions in this installation manual and in the "Safety information" chapter of the operating instructions.
- Put the unit into service only after a successful function test following assembly.
- Put the unit into service only after it has reached room temperature.

3 Description of the unit

3.1 Overview of the unit

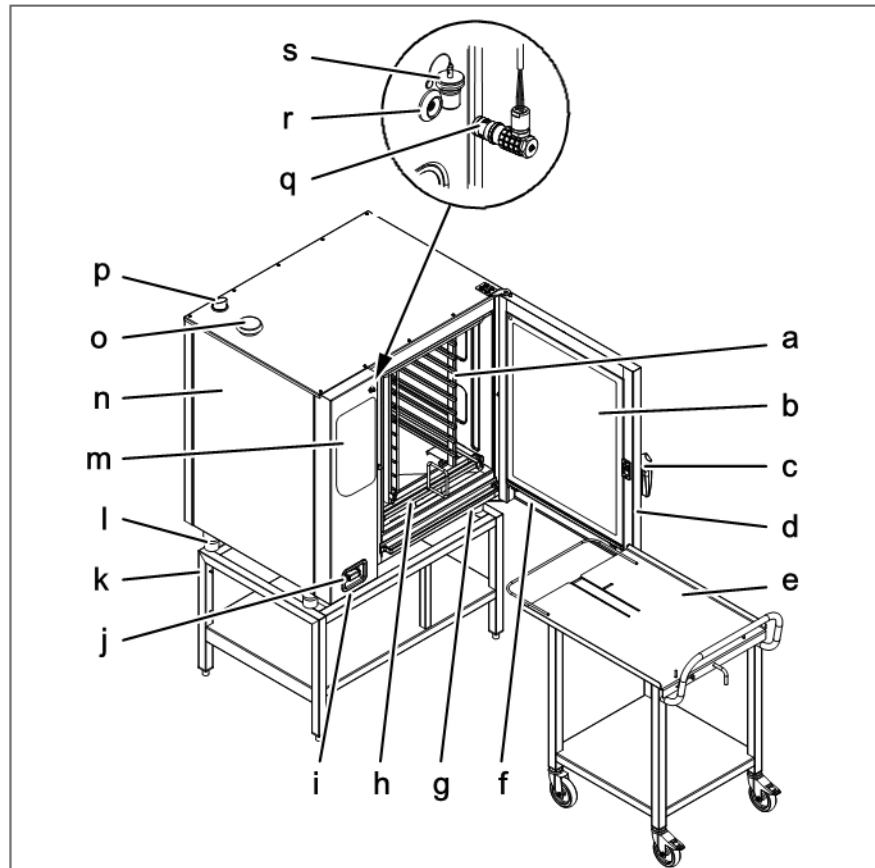

FlexFusion with tray rack trolley

a	Tray rack	k	Base frame (optional)
b	Insulated window	l	Equipment foot
c	Door handle	m	Operating control
d	Cooking zone door	n	Housing
e	Tray rack trolley (optional)	o	Air intake connection fitting
f	Steam drain channel, door	p	Steam outlet connection fitting
g	Steam drain channel, unit	q	Core temperature sensor (optional)

3

Description of the unit

Overview of the unit

h	Guide rail for tray rack (optional)	r	Connection (optional)
i	USB port (covered)	s	Protective cap (optional)
j	Hand shower (optional)		

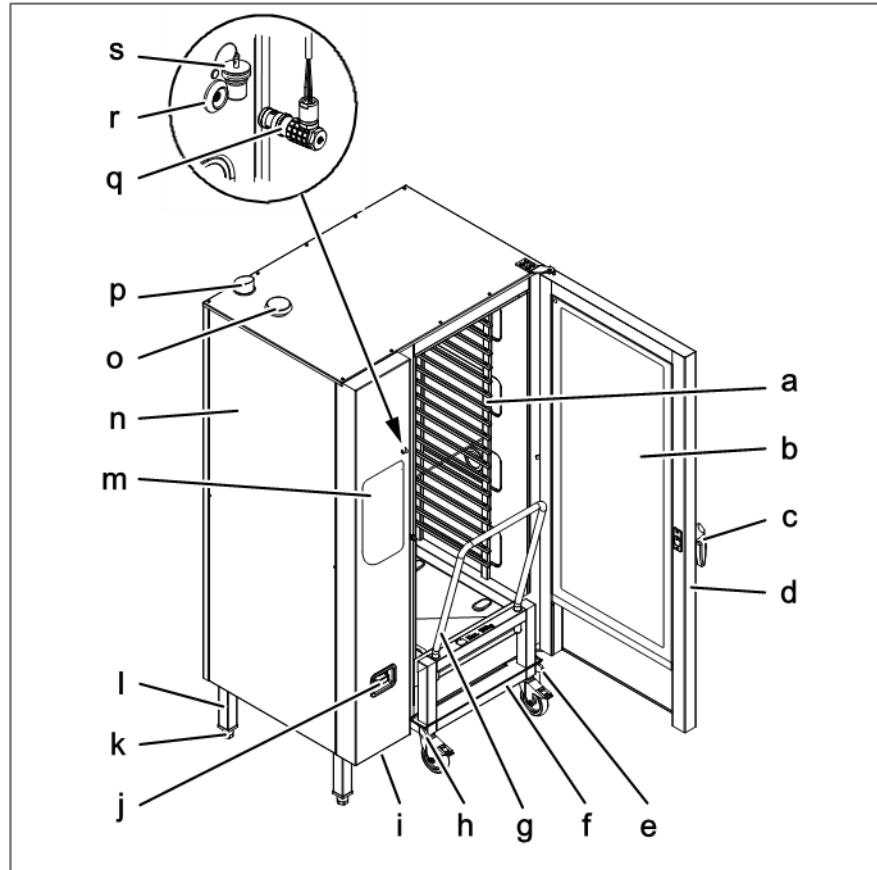

FlexFusion with tray trolley

a	Tray rack	k	Equipment leg
b	Insulated window	l	Equipment foot
c	Door handle	m	Operating control
d	Cooking zone door	n	Housing
e	Guide rail (right)	o	Air intake connection fitting
f	Tray trolley	p	Steam outlet connection fitting
g	Push handle	q	Core temperature sensor (optional)

h	Guide rail (left)	r	Connection (optional)
i	USB port (covered)	s	Protective cap (optional)
j	Hand shower		

3.2 Planning drawing

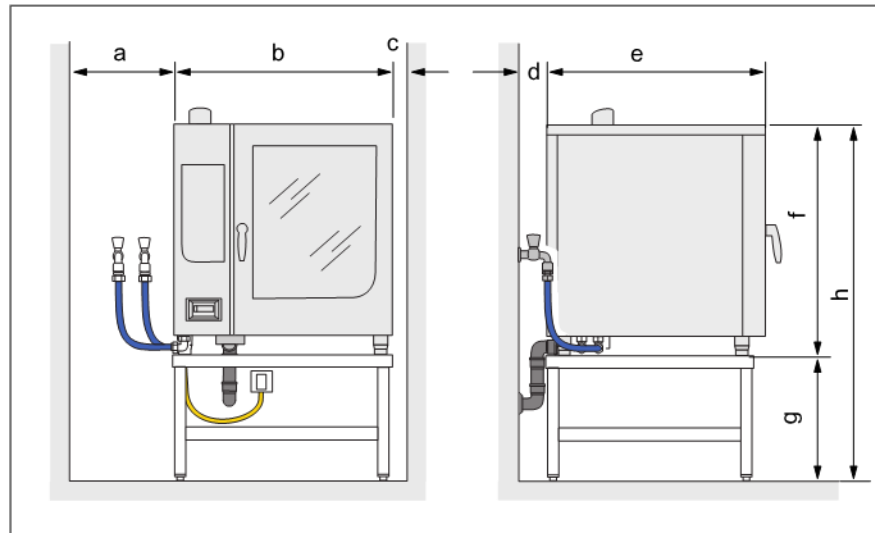

Combisteamer – sizes 6 and 10

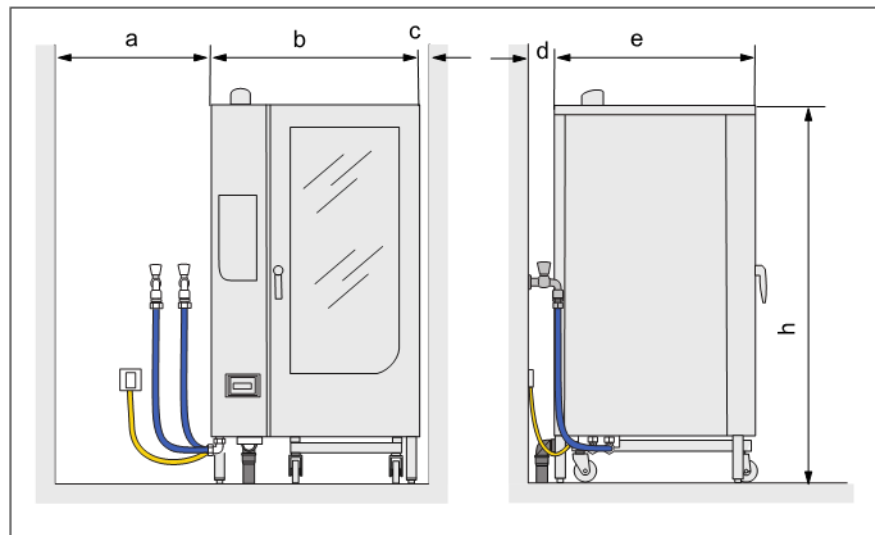

Combisteamer – size 20

3

Description of the unit

Equipment and connection data

Size	a mm (in)	b mm (in)	c mm (in)	d mm (in)	e mm (in)	f mm (in)	g mm (in)	h mm (in)
6.15, 6.21	500 (20)	997 (39)	50 (2)	50 (2)	799 (31)	790 (31)	850 (33)	1640 (65)
10.15, 10.21	500 (20)	997 (39)	50 (2)	50 (2)	799 (31)	1060 (42)	580 (23)	1640 (65)
20.15, 20.21	500 (20)	1075 (42)	50 (2)	50 (2)	813 (32)	--	--	1960 (65)

3.3 Equipment and connection data

Unit size	6.15	6.21	10.15	10.21	20.15	20.21
Dimensions						
Unit Length x width x height mm (in)	1000 x 800 x 790 (39 x 31 x 31)	1000 x 800 x 790 (39 x 31 x 31)	1000 x 800 x 1060 (39 x 31 x 42)	1000 x 800 x 1060 (39 x 31 x 42)	1075 x 813 x 1722 (42 x 32 x 68)	1075 x 813 x 1722 (42 x 32 x 68)
Packaged unit Length x width x height mm (in)	1080 x 960 x 1020 (39 x 38 x 40)	1080 x 960 x 1020 (39 x 38 x 40)	1080 x 960 x 1280 (39 x 38 x 50)	1080 x 960 x 1280 (39 x 38 x 50)	1160 x 960 x 2200 (46 x 38 x 87)	1160 x 960 x 2200 (46 x 38 x 87)
Weight						
Unit kg (lbs)	120 (265)	125 (276)	140 (309)	145 (320)	305 (672)	313 (690)
Packaged unit kg (lbs)	140 (309)	145 (320)	165 (364)	170 (375)	340 (750)	348 (767)
Emissions						
Latent heat rejection (W)	1780	3670	2750	5400	5510	10200
Sensible heat rejection (W)	1190	2450	1840	3600	3670	7100
Noise level (db (A))	< 70					
Ambient climate	5–40 °C (41-104°F), 95 % relative humidity, non-condensing					
Electrical connection						
Protection class	IPX5					

Connected load (kW)	10.4	20.9	15.9	30.5	31.7	60.9
Type of connection	3 N PE 400 V AC 50 Hz					
Maximum line current (A)	15.6	31.0	23.6	45.0	47.0	90.0
Recommended fusing (A)	3 x 16	3 x 35	3 x 25	3 x 50	3 x 63	3 x 100
Soft water connection						
Type of water	Softened tap water, cold					
Carbonate hardness CaCO ₃ (mmol/l)	< 1.5					
Chloride Cl (mg/l)	< 50					
Iron Fe (mg/l)	< 0.1					
Connection pressure (hPa), (bar)	200–600, 2–6					
Type of connection	R ¾", male thread					
Hard water connection						
Type of water	Tap water, cold					
Carbonate hardness CaCO ₃ (mmol/l)	Maximum 4					
Connection pressure (hPa), (bar)	200–600, 2–6					
Type of connection	R ¾", male thread					
Wastewater connection						
Type of wastewater	Dirty water, maximum 80 °C (176°F)					
Connection to unit	Connection fitting, 50 mm (2in) diameter					

4 Transporting the unit

4.1 Information about transporting

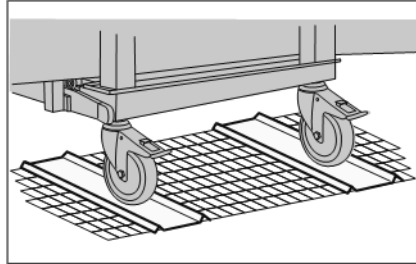

Crossing a grate with the tray trolley

- Prior to transporting the unit to the installation site, ensure that:
 - a) The route has adequate load-bearing capacity; place rails or metal plates underneath if necessary.
 - b) Wall openings are large enough. Removing the packaging reduces the clear width required Equipment and connection data [→ 12] .“

4.2 Transporting to the installation site

	<p>⚠ WARNING</p>
	<p>Risk of property damage and personnel injury from tipping equipment</p> <ol style="list-style-type: none"> a) Do not linger next to or behind raised equipment. b) Move raised equipment carefully.
	<p>SAFETY INSTRUCTIONS</p>
	<p>Risk of physical damage from improper transport</p> <ol style="list-style-type: none"> a) Transport the unit upright. b) Do not tilt or stack the unit. c) Pay attention to protruding parts when transporting the unpacked unit.

4.2.1 Transporting on a pallet

- a) Move the pallet truck under the pallet.
- b) Raise the unit on the pallet.

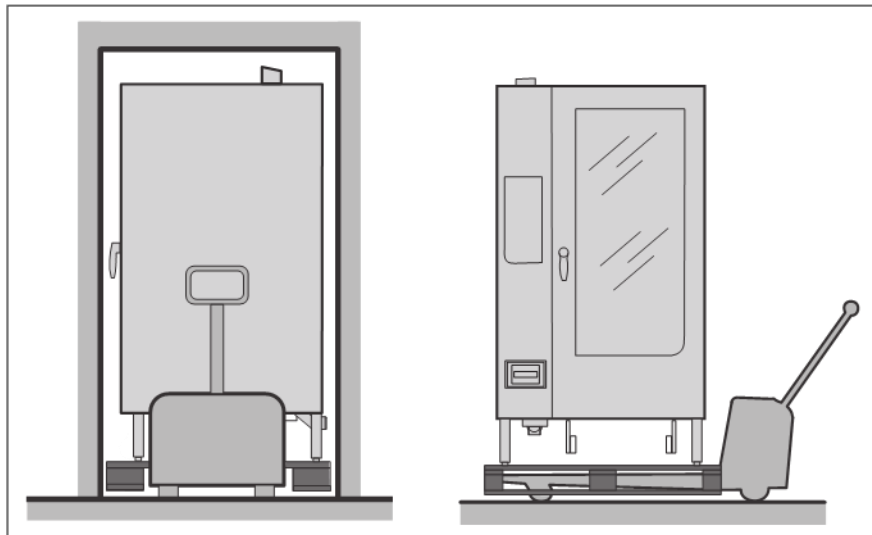

Transporting the unit on a pallet

- c) Move the unit to the installation site.

4.2.2 Transporting without a pallet

SAFETY INSTRUCTIONS	
	<p>Risk of physical damage from improper lifting of the unit</p> <ol style="list-style-type: none"> a) Lift size 6 and size 10 units only with the aid of wooden beams placed underneath.

Unit sizes 6 and 10

Requirement

- Packaging removed except for the pallet

 - a) Move the pallet truck under the unit from the right.
 - b) Place the wooden beams on the lift forks and slide under the unit.
 - c) Lift the unit off the pallet.

4

Transporting the unit

Transporting to the installation site

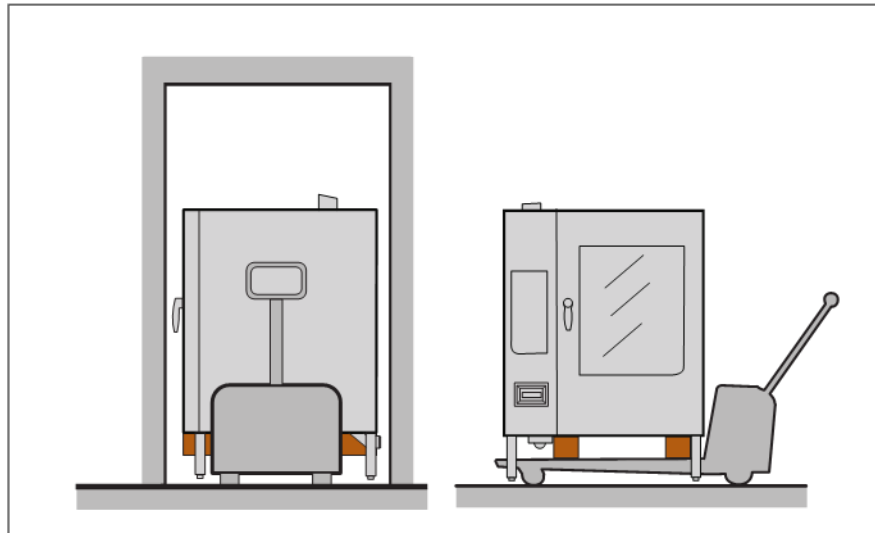

Transporting unit sizes 6 and 10 without a pallet

d) Move the unit to the installation site.

Unit size 20

Requirement

➤ Packaging removed except for the pallet

a) Move the pallet truck under the guide rails of the unit from the right.

b) Lift the unit off the pallet.

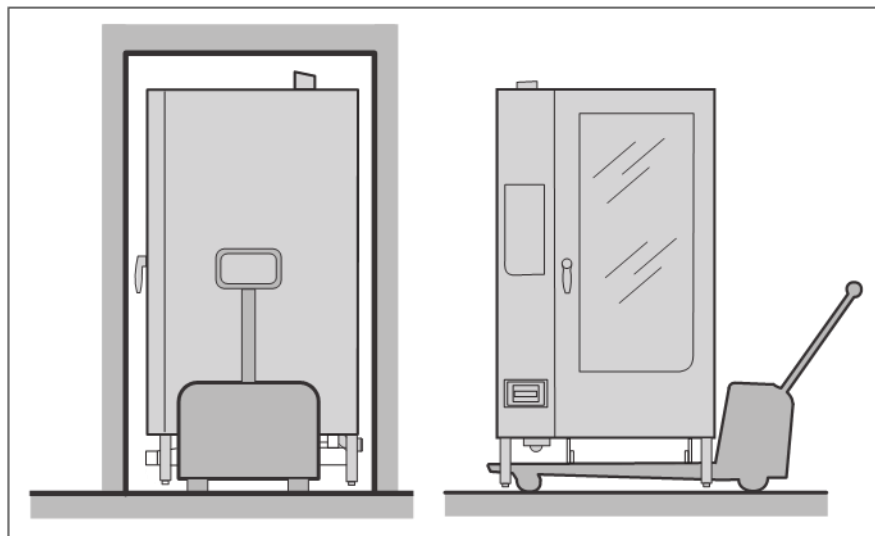

Transporting unit size 20 without a pallet

c) Move the unit to the installation site.

4.2.3 Transporting by lifting and lowering

	 DANGER
	<p>Risk of fatal injury from falling load</p> <p>a) Do not linger under a suspended load.</p> <p>b) Cordon off the hazard area according to regulations.</p>

	SAFETY INSTRUCTIONS
	<p>Risk of physical damage from tightened lifting straps</p> <p>a) Always lift the unit with lifting straps and a spreader bar.</p>

- a) Guide the lifting straps under the pallet and attach them to the spreader bar.
- b) Brace the unit to prevent tipping.
- c) Carefully lift the unit onto the pallet.



4.3 Unpacking the unit

	 WARNING
	<p>Risk of injury from sharp edges</p> <p>Wear protective gloves.</p>

	NOTICE
	<p>When unpacking the unit, inspect it for transport damage. Do not install damaged units or put into service. Enter the information from the nameplate into the commissioning report.</p>

- a) Remove the packaging.
- b) Pull the protective film off the unit.
- c) Remove the packaging material from the cooking zone completely.
- d) Lift the unit off the pallet and place in position.
- e) Clean the unit *see the "Cleaning and maintaining the unit" chapter in the operating instructions.*
- f) Separate and dispose of the packaging material.

5 Setting up the unit

	<p> WARNING</p> <p>Risk of burns from spraying hot fat</p> <p>a) Set up deep fat fryers outside the range of the hand shower.</p>
	<p> CAUTION</p> <p>Risk of crushing from improper setup</p> <p>a) Protect the unit and work area during setup and alignment.</p>
	<p> WARNING</p> <p>Risk of fire from failure to observe applicable regional fire prevention regulations</p> <p>a) Observe applicable regional fire prevention regulations.</p>
	<p>SAFETY INSTRUCTIONS</p> <p>Risk of physical damage from overheating of the unit</p> <p>a) Do not set up the unit close to heat sources.</p>

5.1 Lifting the unit off the pallet

	<p> CAUTION</p> <p>Risk of property damage and personnel injury from tipping equipment</p> <p>a) Do not linger next to or behind raised equipment.</p> <p>b) Move raised equipment carefully.</p>
	<p>SAFETY INSTRUCTIONS</p> <p>Risk of physical damage from lifting the unit incorrectly</p> <p>a) Place the forks of the lift truck next to the waste trap.</p>

Requirement

- > Unit unpacked
- > Protective film removed
- > Unit cleaned

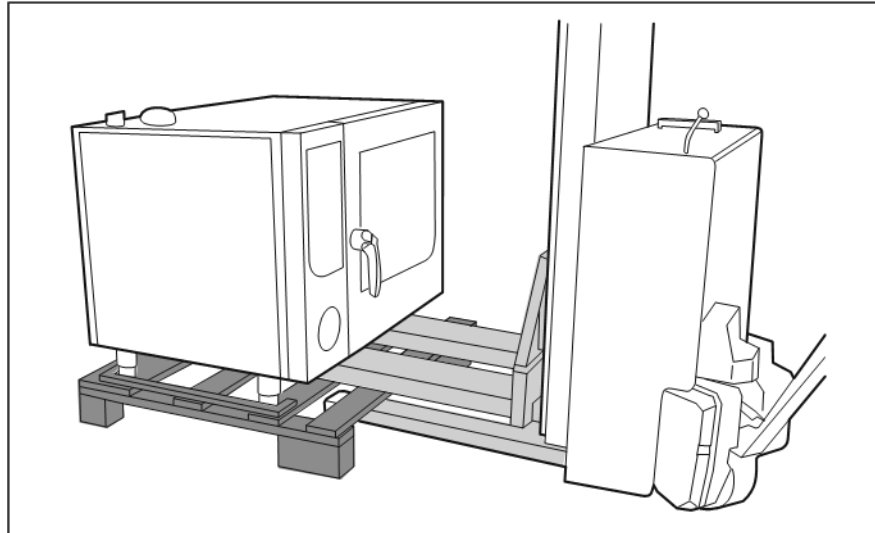

Lifting the unit off the pallet

- a) Slide the forks of the pallet truck under the unit and to the right of the waste trap.
- b) Lift the unit off the pallet.

5.2 Setting up the unit on the equipment legs

Requirement

- The floor must carry the weight of the unit

 - a) Lift the unit with the pallet truck.
 - b) Move the unit to the installation site.
 - c) Place the unit on the floor.
 - d) Set up the unit in accordance with the planning drawing Planning drawing .

5.3 Setting up the unit on a work surface

Requirement

- The base frame must carry the weight of the unit
- Base frame levelled
- Base frame set up in accordance with the planning drawing Planning drawing

 - a) Lift the unit.

5

Setting up the unit Aligning the unit

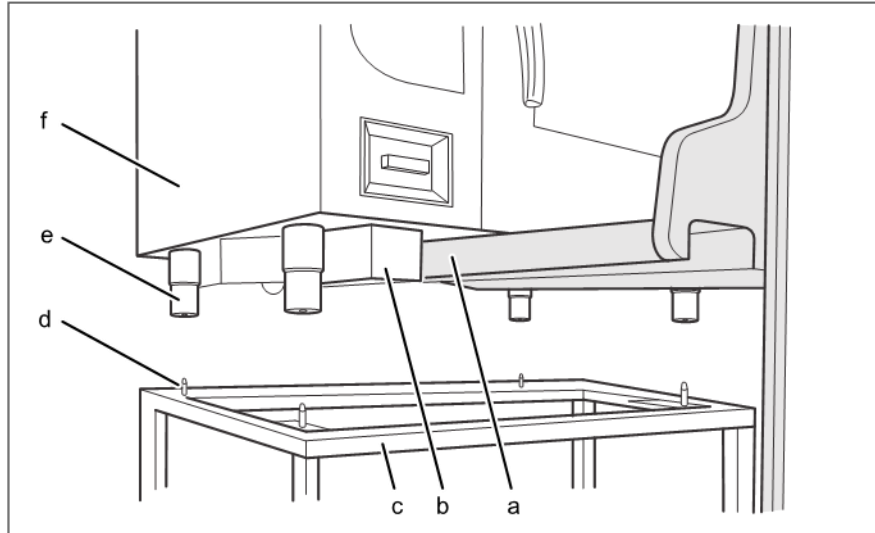

Setting up the unit on a work surface

a	Lift fork	d	Stud bolt
b	Waste trap on the unit	e	Equipment leg
c	Base frame	f	Unit

b) Place the unit over the stud bolts on the work surface.

WARNING

Risk of burns from missing stickers

a) Attach stickers if the upper insertion rails are higher than 1.60 m (63in).

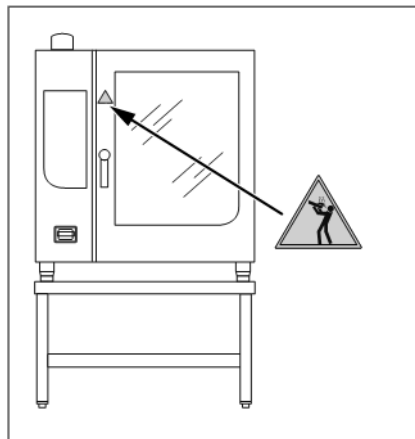

Attach warning sign regarding insertion height

a) Clean the adhesion surface for the sticker.

b) Attach the sticker to the cooking zone door at a height of 1.6 m (63in).

5.4 Aligning the unit

5.4.1 Aligning countertop units

Requirement

- > Base frame levelled
- a) Place a spirit level on the unit.
- b) Screw the equipment legs in or out to level the unit.

5.4.2 Aligning floor-standing units

NOTICE

The tray trolley is needed to align a floor-standing unit.
Prepare the tray trolley.

- a) Screw the equipment legs in or out to align the unit.
- b) Open the cooking zone door.

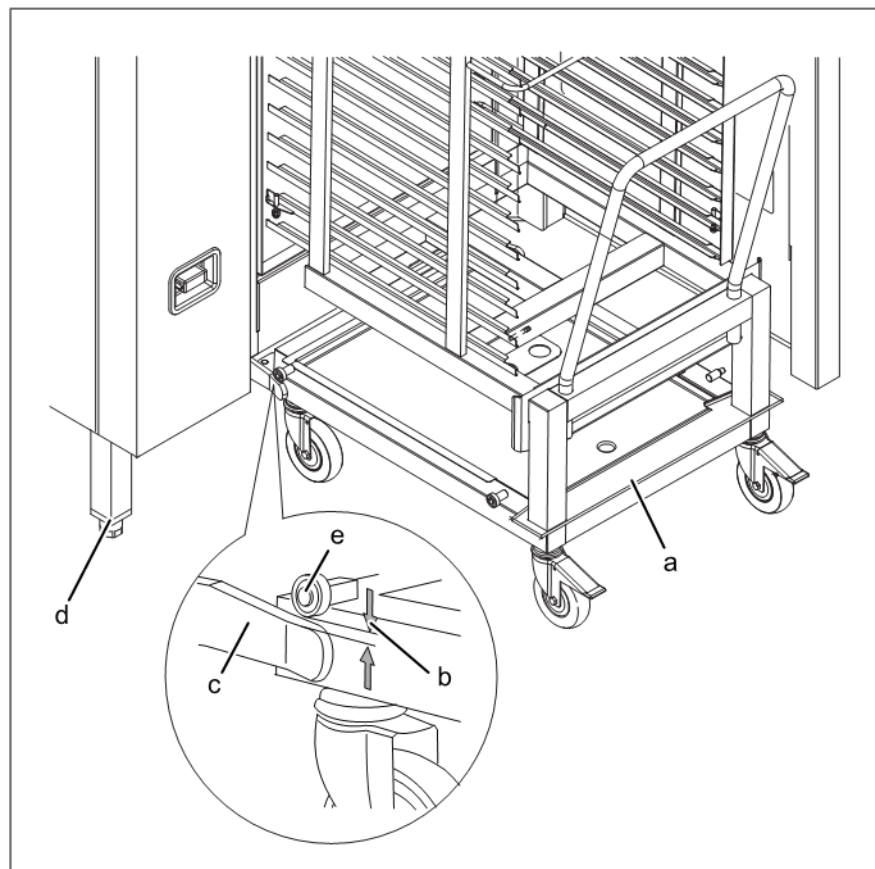

Aligning the unit with the tray trolley

a	Tray trolley	d	Equipment leg
b	Distance between roller and support rail	e	Roller
c	Support rail		

- c) Place the tray trolley against the support rails.
 - d) Screw the equipment legs in or out until the rollers are 1 to 5 mm above the support rails.
 - e) Retract the tray trolley.
 - f) Level the support rails.
 - g) Push the tray trolley against the unit until it stops.
 - h) Remove the push handle.
 - i) Close the cooking zone door.
- ⇒ The unit is aligned correctly.

5.5 Minimum clearances

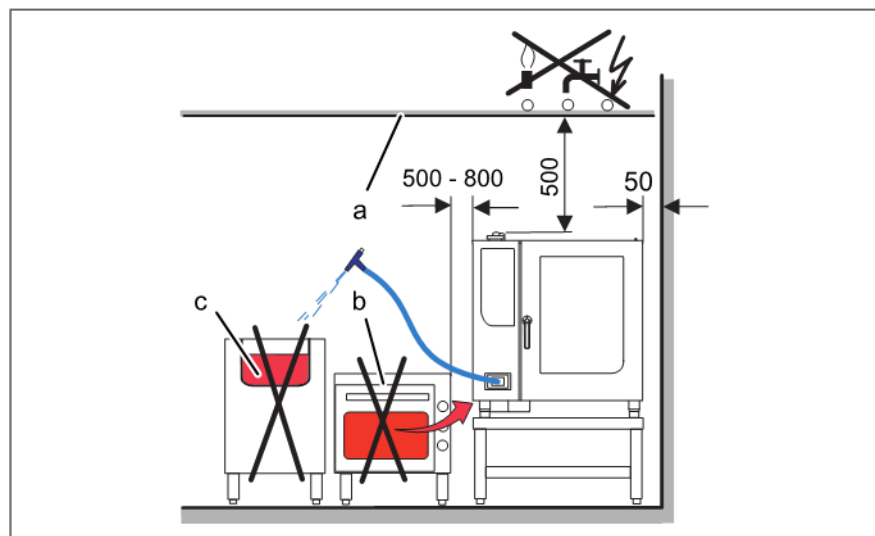

FlexFusion minimum clearances

a	Ceiling
b	Baking oven
c	Deep fat fryer

The following clearances from walls, ceilings or other equipment must be provided when setting up the unit:

- Left, right and behind: at least 50 mm (2in).
- If possible at the left, 500 mm (20in) for service work

- If possible at the left, 800 mm (31in) for parking the trolley tray
- At the left, 500 mm (20in) to heat sources (baking ovens) so that the cooling air for the unit is not heated.
- Left and right, one length of the hand shower so that no water can be sprayed into the hot deep fat fryer.
- To ceilings, at least 500 mm (20in). There must be no water, gas or electric lines in the ceiling above the unit.

6 Connecting the unit

6.1 Opening and closing the housing

	<p>⚠ DANGER</p>
	<p>Risk of electric shock</p> <p>a) Prior to working on the unit, ensure that the unit has been disconnected from the mains.</p> <p>b) Do not operate the unit with the housing open.</p>
	<p>⚠ WARNING</p>
	<p>Risk of injury from sharp edges</p> <p>a) Wear protective gloves.</p>
	<p>SAFETY INSTRUCTIONS</p>
	<p>Risk of physical damage from damage to the lines</p> <p>a) Remove and attach housing components carefully.</p>

6.1.1 Removing and attaching the side panel

Removing the side panel

- Unscrew the bolts on the bottom of the side panel.
- Pull the bottom of the side panel forward.

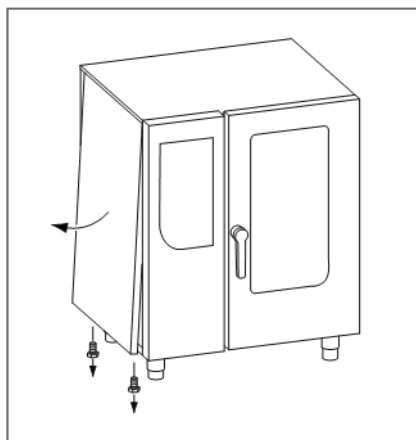

Removing and attaching the side panel

- Remove the side panel.

Attaching the side panel

	SAFETY INSTRUCTIONS
	Risk of physical damage from squeezing the lines When attaching the side panel, make sure that no lines are squeezed.

- a) Insert the top edge of the side panel.

	SAFETY INSTRUCTIONS
	Risk of physical damage from a loose side panel a) The side panel must be in contact with the unit on all sides.

- a) Carefully push the bottom of the side panel inward.
- b) Secure the bottom of the side panel with bolts.
- c) Check that the side panel is in contact with the unit on all sides.

6.2 Making the electrical connection

- Ensure that only licensed electricians connect the unit.
- Note the information on the nameplate.
- Observe applicable regional regulations of the electrical utility.

6.2.1 Connected loads for various connection voltages

Unit size	6.15	6.21	10.15	10.21	20.15	20.21
Electricity network type	3PE / AC 50/60Hz , 3NPE / AC 50/60Hz					
Voltage (V)	200					
Connected load (kW)	9.7	16.3	14.7	25.5	29.4	50.9
Fusing (A)	35	50	50	80	100	180
Voltage (V)	208					
Connected load (kW)	10.2	17.4	15.7	27.3	31.4	54.6
Fusing (A)	35	50	50	80	100	180
Voltage (V)	230					
Connected load (kW)	12.6	21.4	19.3	33.6	38.6	67
Fusing (A)	35	63	63	100	125	180
Voltage (V)	240					
Connected load (kW)	13.7	23.3	21	36.5	42	72.9
Fusing (A)	35	63	63	100	125	180
Voltage (V)	380					
Connected load (kW)	9.4	18.9	14.4	27.6	28.7	55
Fusing (A)	16	35	25	50	50	100
Voltage (V)	400					

Connected load (kW)	10.4	20.9	15.9	30.5	31.7	60.9
Fusing (A)	16	35	25	50	50	100
Voltage (V)	415					
Connected load (kW)	11.2	22.5	17.1	32.8	34.1	65.5
Fusing (A)	16	35	25	50	50	100
Voltage (V)	440					
Connected load (kW)	10.4	20.9	15.8	30.5	31.5	60.9
Fusing (A)	16	35	25	50	50	100
Voltage (V)	480					
Connected load (kW)	12.3	20.9	18.9	32.6	37.6	65.1
Fusing (A)	16	35	25	50	50	100

6.2.2 Connecting to the electric mains

Electric power cable

An electric power cable of the type HO7RN-F must be used to connect the unit to the electric mains.

Residual-current protective device

The unit can be connected to a residual-current protective device. The residual-current protective device must incorporate a residual-current protective switch of type B (RCD Type B) in order to detect AC fault currents, pulsating DC currents and continuous DC currents.



RCD switch type B circuit symbol

6

Connecting the unit

Making the electrical connection

SAFETY INSTRUCTIONS
<p>Risk of property damage and personal injury from improper installation</p> <p>a) In the case of a permanent electrical connection, install an all-phase disconnect switch before the unit.</p>

Permanent connection

Install an all-phase disconnect switch if the unit will be connected permanently to the electric mains.

SAFETY INSTRUCTIONS
<p>Risk of property damage and personal injury from improper installation</p> <p>a) The plug-in connection must be readily accessible.</p>

Plug-in connection

If the unit will be connected to the electric mains by a plug, use a plug and socket that comply with IEC 60309. The socket must be readily accessible so that the unit can be disconnected from the electric mains at any time.

6.2.3 Connecting the electric power cable to the unit

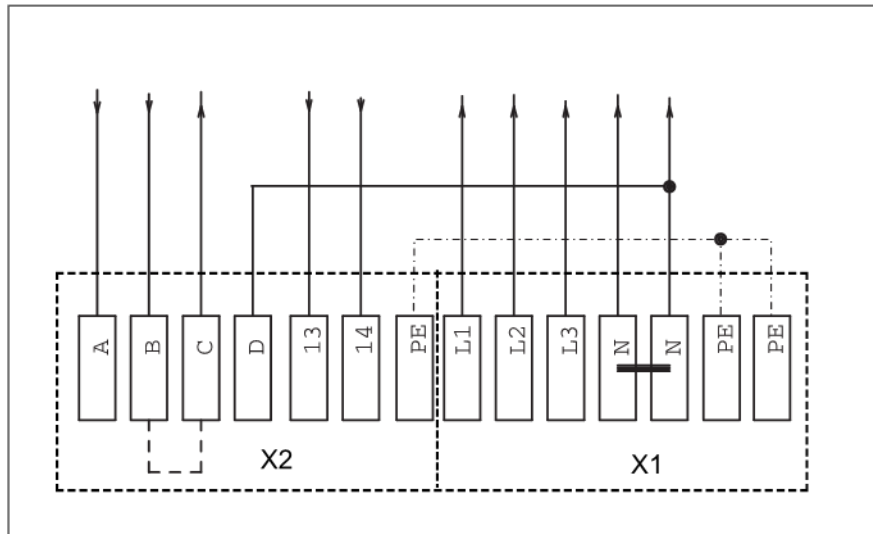

Electrical connection terminal diagram in the unit

A, B, C, D	Power optimizing system	PE	Protective earth
13, 14	Floating contact	X1	Mains connection
L1, L2, L3	Phases	X2	Power optimizing system connection
N	Neutral conductor		

Length of connection cable in the unit

Model	Length mm (in)
6.15, 6.21	1000 (39)
10.15, 10.21	1200 (47)
20.15, 20.21	720 (28)

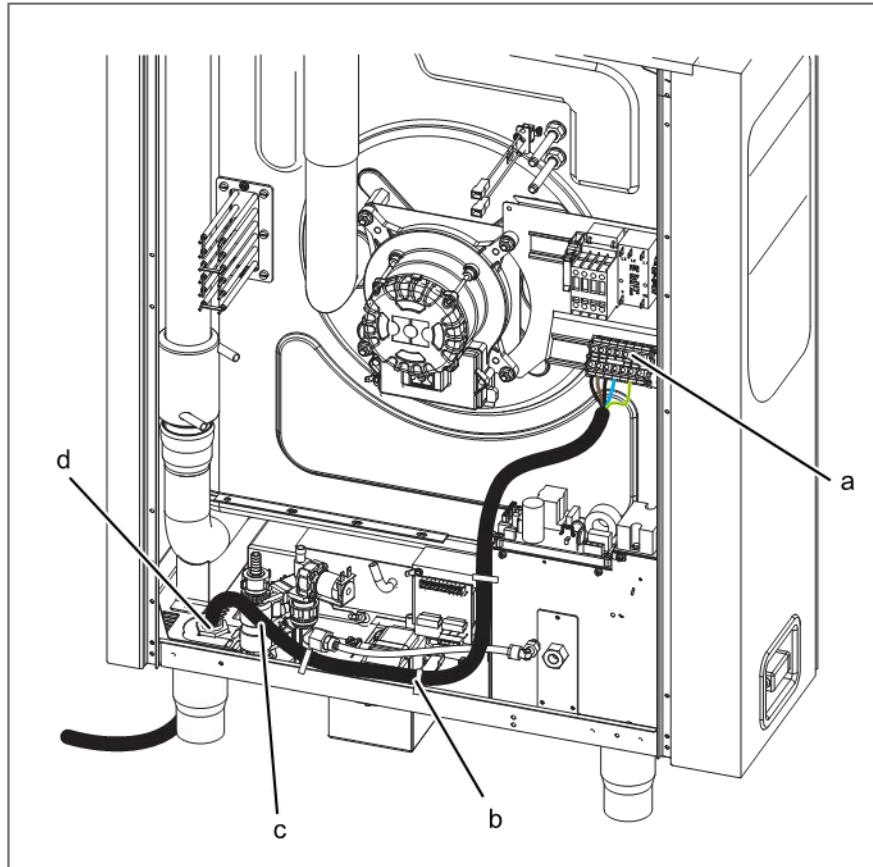

Connecting the electric power cable

a	Connection terminals	c	Electric power cable
b	Cable tie	d	Cable gland

Requirement

- Electrical connection to the unit matches the information on the nameplate
 - Housing open
 - Electric power cable sufficiently long
- a) Insert the electric power cable into the unit through the cable gland.
 - b) Connect the electric power cable in accordance with the terminal diagram.
 - c) Secure the electric power cable to the unit with cable ties.
 - d) Tighten the cable gland securely to provide strain relief.

6.3 Connecting the power optimizing system

The unit can be connected to a power optimizing system. The line length in the unit corresponds to the length of the electric power cable.

Requirement

- Unit disconnected from the electric mains
- Left side panel removed
- a) Pull the connection cable into the unit through the opening next to the entry for the electric power cable.
- b) Bring the connection cable to the connection terminals.
- c) Attach the connection cable in accordance with the terminal diagram.
- d) Secure the connection cable with cable ties.
- e) Enter the power optimizing system in the basic settings.

6.4 Connecting the unit to the network

The units can be connected to an Ethernet network with a RJ45 plug.

Requirements for network connection

Type of network	Ethernet
Cabling	In accordance with EN 50173
Cable quality	4-twin, shrouded patch cable Cat-6 S/FTP
Connection to the unit	Shrouded RJ45 plug
Cable length in the unit	As per electric power cable

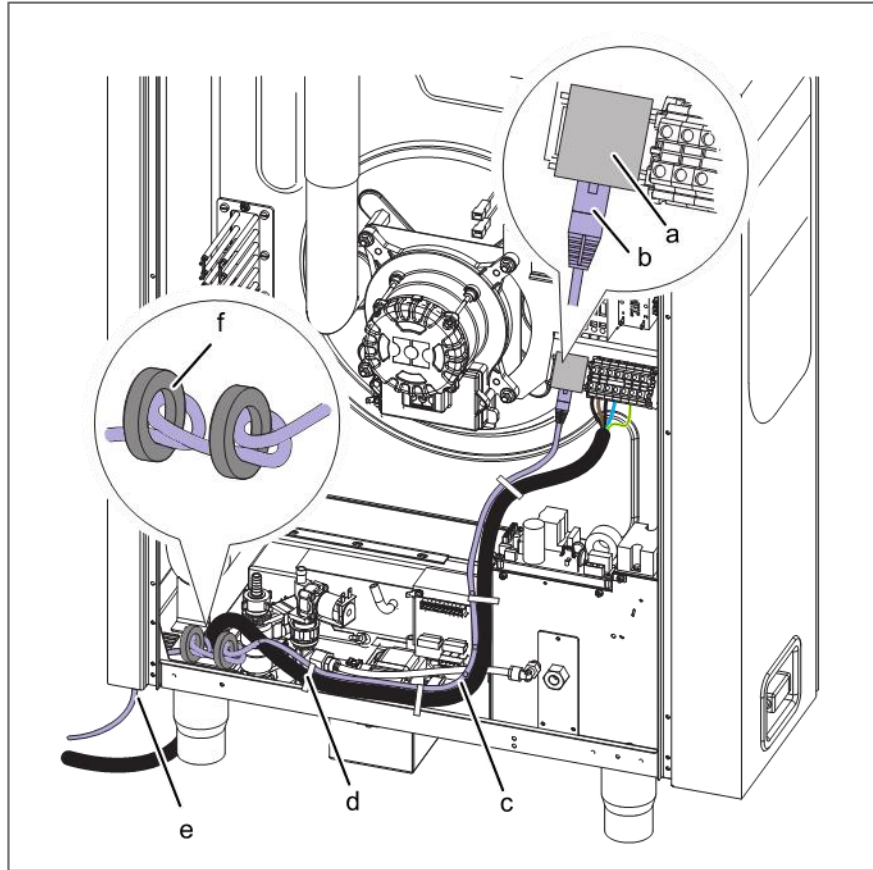

Connecting the network cable

a	RJ45 socket	d	Cable tie
b	RJ45 plug	e	Feed-through in the base of the unit
c	Network cable	f	Ferrite rings

Requirements

- Unit is disconnected from the electric mains
- Side panel is removed
- a) Pull the network cable alongside the electrical connection into the unit.
- b) Lead the network cable through the two ferrite rings with one turn each.
- c) Connect the network cable to the unit with the RJ45 plug.
- d) Put the unit into service and under basic setting enter the network address or select DHCP.

6.5 Basic settings

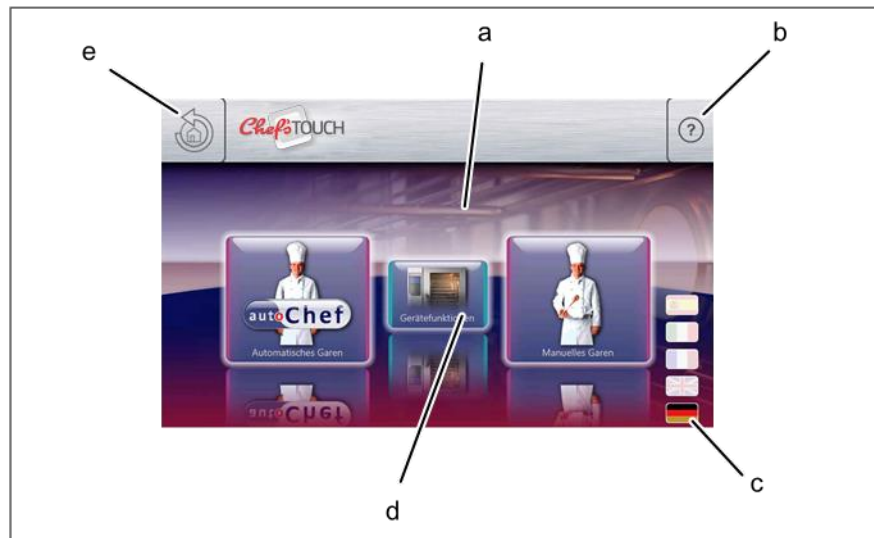

Start menu for FlexFusion ChefsTouch

a	Start menu for FlexFusion ChefsTouch	d	Key for "Unit functions"
b	Key for <i>FlexFusion Help</i>	e	Key for "Back"
c	Language selection		

By entering the password "2100", the basic settings for the installation can be displayed and changed.

Requirements

- > The unit is switched on
- a) Touch the key for "Unit functions" in the main menu.
- b) Enter the password "2100" with the keypad.
- c) Select and set parameters in the menu.

Basic setting	No.	Standard value	Setting range	Explanation
Actual voltage	1			Enter the local, mean voltage between the outer cables.
Date / Time	2		dd mm yyyy/ hh mm	

Basic setting	No.	Standard value	Setting range	Explanation
Altitude	3	0	0 - 3	Request the altitude above sea level from the closest weather station. If the altitude is unknown, enter 0 – 500 m. <ul style="list-style-type: none"> ▪ 0 = 0 - 500 m (0 - .31 mi) ▪ 1 = 501 – 1000 m (.31 - .62 mi) ▪ 2 = 1001 – 1500 m (.62 - .93 mi) ▪ 3 = > 1500 m (.93 mi)
Audio setting	4	20	0 – 180 s	Duration of the audible signal 0 = Signal off
Units	5		Metric/Imperial	
Water filter maintenance	6		Litres > 0 0 = No maintenance message	Water quantity up to the maintenance message
Network	7		Network address and DHCP	Select Ethernet interface
Kitchen control technology			Disabled/enabled	Address of port and unit can be entered.
80% power	4	0	0 = No 1 = Yes	Yes = Power limited to 80 % (for special applications)
Power optimizing system connected?	5	0	0 = No 1 = Yes	If the power optimizing system is connected, "Yes" must be selected in order for the unit to heat.

6.6 Making the water connection

6.6.1 Information about the water connection

Installation work involving drinking water must be performed by an authorised plumbing contractor. Observe applicable regional regulations with regard to drinking water installations and connection data. Equipment and connection data [→ 12]

6.6.2 Connecting hard and soft water

The unit is equipped with a connection for:

- Soft water for generating steam
- Hard water for cooling, rinsing and WaveClean

SAFETY INSTRUCTIONS	
Hygiene risk from contaminated drinking water	
a) The connection to the drinking water supply must be equipped with a backflow preventer.	

NOTICE	
Always connect hard and soft water to the unit	

SAFETY INSTRUCTIONS	
Risk of physical damage from the wrong water quality	
a) Ensure that the water quality complies with the equipment and connection data.	

SAFETY INSTRUCTIONS	
Hygiene risk from contaminated drinking water	
a) The connection to the drinking water supply must be equipped with a backflow preventer.	

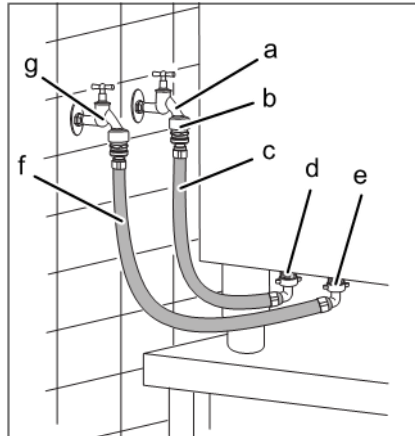

Hard and soft water connection

a	Soft water tap	e	Hard water connection fitting
b	Backflow preventer, installed	f	Hard water hose
c	Hose	g	Backflow preventer, installed
d	Soft water connection fitting	h	Hard water tap

Requirement

- > Water quality meets specifications
- > Backflow preventers installed
- > Required water pressure available

- Pressure-resistant hoses suitable for drinking water available
- a) Connect the hoses to the water taps.
- b) Open the water taps and flush the hoses.
- c) Insert dirt filters into the two water connection fittings.
- d) Connect hoses to the unit.
- e) Open the water taps and check the threaded fittings for leaks.

6.6.3 Connecting soft water twice

If only a soft water connection is available at the installation site, the hard water connection fitting and the soft water connection fitting must be connected by means of a T-piece.

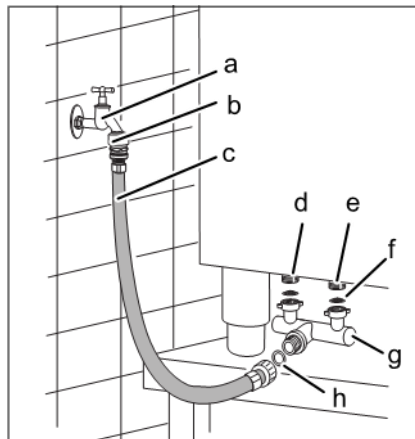

Soft water connection twice

a	Soft water tap	e	Hard water connection fitting
b	Backflow preventer	f	Dirt filter
c	Hose	g	T-piece
d	Soft water connection fitting	h	Seal

Requirement

- Hose connected to soft water tap
- a) Insert a dirt filter into the hard and soft water connection fittings.
- b) Connect the T-piece with seals to the connection fittings.
- c) Connect hose with seal to the T-piece.
- d) Open the soft water tap and check the threaded fittings for leaks.

6.7 Making the wastewater connection

6.7.1 Information about the wastewater connection

Installation work involving wastewater must be performed by an authorised plumbing contractor. Observe the applicable regional regulations of the sewage utility involved.

6.7.2 Connecting the wastewater line permanently

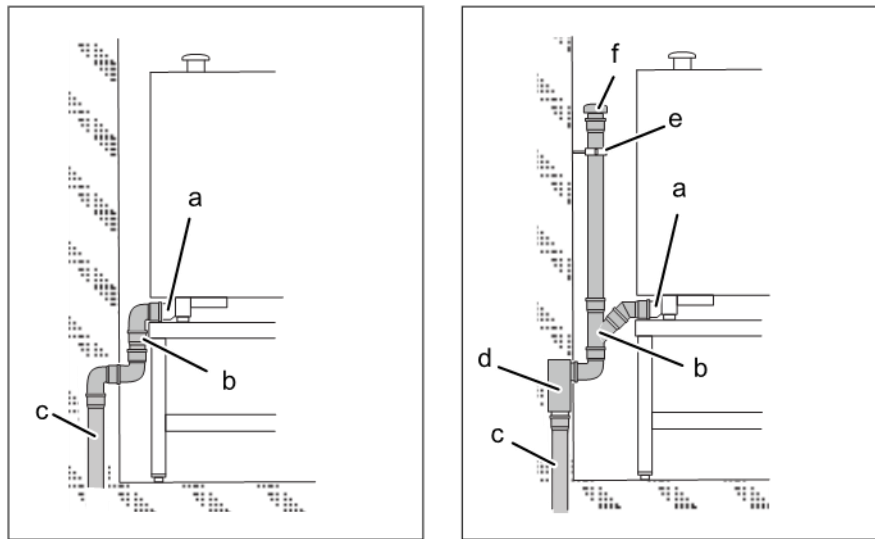

Connecting the wastewater line permanently

a	Wastewater discharge from unit	d	Wastewater system trap
b	Wastewater line	e	Pipe clamp
c	Wastewater system	f	Vacuum breaker valve

NOTICE

If a waste trap is installed in the wastewater system, a vacuum breaker must be installed in the wastewater line.

Requirement

Polypropylene (PP) pipes and elbows



- Heat-resistant to 95 °C (203°F)
- Nominal diameter 50 mm (2in)
- Maximum pipe length 1.0 m (39in)

- a) Install wastewater line up to connection to the sewer system.
- b) Secure the wastewater line with clamps.
- c) Pour tap water into the wastewater trap on the unit.

6.8 Making the exhaust air connection

6.8.1 Information about the exhaust air connection

When setting up the unit under an exhaust hood, observe the applicable regional regulations for ventilation systems.

	 CAUTION
	Risk of physical damage from fouling of the exhaust air ducts a) Do not incorporate the exhaust air line directly into an exhaust air system.
	 CAUTION
	Risk of corrosion damage from condensate a) Install the exhaust air line such that condensate cannot collect.

Requirement

Flexible aluminium hose

- Nominal diameter 63 mm for sizes 6 and 10
- Nominal diameter 76 mm for size 20
- Maximum length of hose 2.5 m (98in)
- Temperature-resistant to 180 °C (356°F)

- a) Connect hose to exhaust air connection fitting.
- b) Route hose to the exhaust hood with about a 3° rise.
- c) Secure end of hose about 50-200 mm (2-8in) below the exhaust hood.

7 Putting the unit into service

7.1 Filling out the commissioning report

General		Yes	No
Information from the nameplate entered? SN: _____ Typ: _____ QN (Hi): _____ E: _____ Bez: _____ Item-Nr.: _____ (if listed)		<input type="checkbox"/>	<input type="checkbox"/>
Obvious damage to the unit? What and where?: _____		<input type="checkbox"/>	<input type="checkbox"/>
Unit levelled?		<input type="checkbox"/>	<input type="checkbox"/>
Elements that can tilt levelled? (for instance: pans)		<input type="checkbox"/>	<input type="checkbox"/>
Electrical connection		Yes	No
Power connection made properly?		<input type="checkbox"/>	<input type="checkbox"/>
<input type="checkbox"/> Equipotential bonding	<input type="checkbox"/> Power optimizing system		
<input type="checkbox"/> Floating contact	<input type="checkbox"/> ...		
Electrical connections made properly?		<input type="checkbox"/>	<input type="checkbox"/>
Residual-current protective device connected immediately before this unit?		<input type="checkbox"/>	<input type="checkbox"/>
Residual-current protective device connected before this and other units?		<input type="checkbox"/>	<input type="checkbox"/>

7

Putting the unit into service

Filling out the commissioning report

Water connection	Yes	No
Minimum connection pressure available? Connection pressure: _____ bar	<input type="checkbox"/>	<input type="checkbox"/>
Water connection made properly?	<input type="checkbox"/>	<input type="checkbox"/>
Lines and connections have no leaks?	<input type="checkbox"/>	<input type="checkbox"/>
Mixing battery mounted properly?	<input type="checkbox"/>	<input type="checkbox"/>

Wastewater connection	Yes	No
Wastewater connection made properly?	<input type="checkbox"/>	<input type="checkbox"/>
<input type="checkbox"/> On-site waste trap <input type="checkbox"/> Vacuum breaker	<input type="checkbox"/>	<input type="checkbox"/>
<input type="checkbox"/> Funnel discharge		
Wastewater pipe dimension: _____ mm (in)		

Exhaust air connection	Yes	No
Set up under exhaust hood?	<input type="checkbox"/>	<input type="checkbox"/>
Connected to exhaust air duct?	<input type="checkbox"/>	<input type="checkbox"/>
Exhaust air pipe dimension: _____ mm (in)	<input type="checkbox"/>	<input type="checkbox"/>
Exhaust air pipe length: _____ m (in)		

Final notes	Yes	No
Was the unit put into service?	<input type="checkbox"/>	<input type="checkbox"/>
Comments:	<input type="checkbox"/>	<input type="checkbox"/>
Operator trained?		

Electrical installation was provided by:			
Company	Installer	City, date	Signature

Water installation was provided by:			
Company	Installer	City, date	Signature

Wastewater installation was provided by:			
Company	Installer	City, date	Signature

Exhaust air connection was provided by:			
Company	Installer	City, date	Signature

Operator training was provided by:			
Company	Installer	City, date	Signature



Henny Penny Corporation
P.O.Box 60
Eaton, OH 45320

1-937-456-8400
1-937-456-8402 Fax

Toll free in USA
1-800-417-8417
1-800-417-8434 Fax

www.hennypenny.com



F M 0 8 - 4 5 3 - A

Henny Penny Corp., Eaton, Ohio 45320, Revised 2-19-15