



OPERATOR'S M A N U A L

FlexFusion™ ELECTRIC PLATINUM COMBI

MODEL

FPE-615

FPE-621

FPE-115

FPE-121

FPE-215

FPE-221



HENNY PENNY®

Engineered to Last

REGISTER WARRANTY ONLINE AT WWW.HENNYPENNY.COM

Read instructions before operating the appliance

Operating and display elements

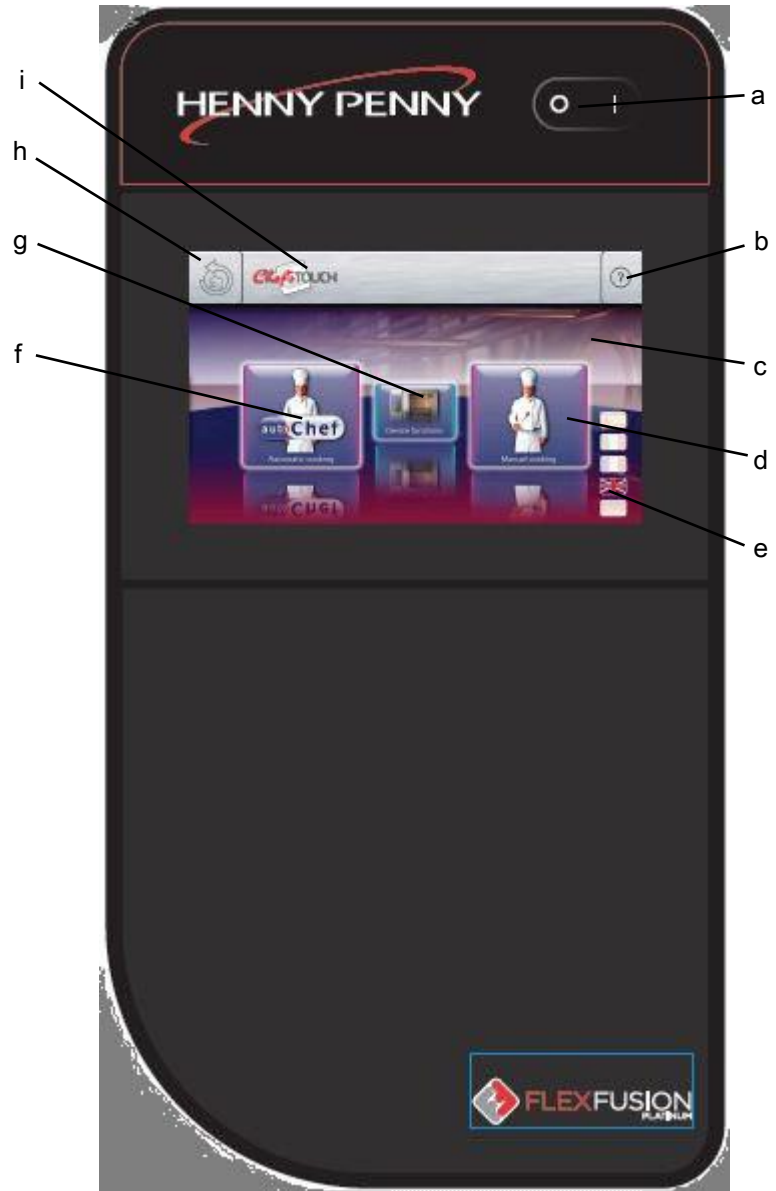

a	<i>On Off</i> button	f	"Automatic cooking" button
b	<i>FlexiHelp</i> button	g	"Equipment functions" button
c	Operating element with touchscreen	h	<i>Back</i> button
d	"Manual cooking" button	i	Information bar
e	<i>Language selection</i> button		



Directory of contents

1	Introduction	8
1.1	About this manual	8
1.1.1	Explanation of signs	9
1.2	Intended use	11
1.3	Warranty	11
2	Safety information	12
3	Description of the unit	15
3.1	Overview of the unit	15
3.1.1	Countertop unit	15
3.1.2	Floor-standing unit	16
3.2	Features	17
3.2.1	Characteristics	17
3.2.2	Operating modes	17
3.2.3	Types of cooking	18
3.2.4	Expanded cooking functions	19
3.2.5	Core temperature measurement	21
3.2.6	Barcode scanner	22
3.2.7	USB port	22
3.2.8	HACCP logging	22
3.2.9	VideoAssist	22
3.2.10	WaveClean automatic cleaning	23
3.2.11	CombiDoctor (self-diagnostic program)	23
3.3	Operating, control and display element functions	23
3.4	Application	24
3.4.1	Plate capacity during regeneration	24
3.4.2	Loading capacity	25

3.4.3	Temperature standard setting	25
3.4.4	Core temperature standard setting	26
3.5	Chef's Touch equipment controls	26
3.5.1	Touchscreen operation	28
3.5.2	Display elements	29
4	Putting the unit into service	31
5	Operating the unit	32
5.1	Switching the unit on and off	32
5.1.1	Switching on	32
5.1.2	Switching off	32
5.2	Opening and closing the cooking zone door	33
5.2.1	Opening the single-stage door latch	33
5.2.2	Closing the single stage door latch	33
5.2.3	Opening the two-stage door latch	34
5.2.4	Closing the two-stage door latch	34
5.3	Loading and emptying the unit	35
5.3.1	Loading and emptying	35
5.3.2	Loading and emptying with a tray rack trolley	36
5.3.3	Loading and emptying with a tray trolley	37
5.4	Using the core temperature sensor	39
5.4.1	Measuring with a 4-point core temperature sensor	39
5.4.2	Measuring with a sous-vide core temperature sensor	40
5.4.3	Measuring the core temperature when cooking frozen food	40
5.5	Making the basic settings	41
5.5.1	Opening the Setting menu	41
5.5.2	Retrieving equipment information	42
5.5.3	Setting the date and time	43
5.5.4	Presetting the language selection	44

5.5.5	Activating and cancelling inhibit operation	45
5.6	Basic functions	46
5.6.1	Setting the cooking temperature	46
5.6.2	Setting the cooking time and continuous operation	47
5.6.3	Setting the core temperature	49
5.6.4	Setting the fan speed and direction of rotation	50
5.6.5	Inserting and removing a USB flash drive	50
5.6.6	Exporting the HACCP log	51
5.7	Equipment functions	51
5.7.1	Opening the Equipment function menu	51
5.8	Manual cooking	51
5.8.1	Opening the Manual cooking menu	52
5.8.2	Creating a cooking program	52
5.9	User's own cooking programs	53
5.9.1	Creating a cooking program	53
5.9.2	Saving the cooking program	55
5.9.3	Exporting a cooking program	58
5.10	Automatic cooking (autoChef)	58
5.10.1	Opening the Automatic cooking menu	58
5.10.2	Finding and opening a cooking program	59
5.10.3	Starting the cooking program	60
5.10.4	Ending the cooking program	61
5.10.5	Modifying the cooking program	61
5.10.6	Deleting a cooking program	62
5.10.7	Exporting and importing a cooking program	63
5.11	Pausing and finishing use	64
6	Cleaning and caring for the unit	65
6.1	Preventing corrosion	65
6.2	Remove rust spots	65

6.3	Cleaning the housing	66
6.4	Cleaning the handle, operating elements and operating panel membrane	66
6.5	Cleaning the touchscreen	67
6.6	Cleaning the door seal	68
6.7	Cleaning the cooking zone door	69
6.7.1	Cleaning the door with hygienic glazing	69
6.8	Cleaning the steam outlet	69
6.9	Cleaning the condensation hood (optional)	70
6.10	Removing calcium deposits from the unit	71
6.11	Cleaning the cooking zone automatically with WaveClean	71
6.11.1	Preparing for cleaning	71
6.11.2	Selecting the cleaning level	72
6.11.3	Inserting the cleaning cartridge	72
6.11.4	Starting automatic cleaning	73
6.11.5	Cancelling automatic cleaning	73
6.11.6	Ending automatic cleaning	73
6.12	Cleaning the cooking zone manually	74
6.12.1	Preparing the cooking zone	74
6.12.2	Starting the cleaning program	74
6.12.3	Spraying the cleaner	75
6.12.4	Allowing the cleaner to act	75
6.12.5	Starting cleaning	75
6.12.6	Rinsing the cooking zone	76
6.12.7	Drying the cooking zone	76
6.13	Swinging the air diverter open and closed	77
6.14	Inspecting the unit	78
6.14.1	Performing a visual inspection	78
6.14.2	Running CombiDoctor (self-diagnostic program)	78



7	Troubleshooting	80
7.1	Causes of errors and remedies	80
7.2	Nameplate	80
8	Dispose of unit in an environmentally responsible manner	81

1 Introduction

1.1 About this manual

The instruction manual is part of the unit and contains information:

- on safe operation
- on cleaning and care
- on remedial actions in case of faults

Observe and adhere to the following instructions:

- Read the instruction manual completely before operating the unit for the first time.
- Make the instruction manual available to the operator at all times at the operating site of the unit.
- Insert any supplements from the manufacturer.
- Preserve the instruction manual throughout the service life of the unit.
- Pass on the instruction manual to any subsequent operator of the unit.



Target group

The target group of the instruction manual is the operator, who is entrusted with the operation, cleaning and care of the unit.

Figures

All figures in this manual are intended as examples. Discrepancies between these and the actual unit can arise.

1.1.1 Explanation of signs

	 DANGER
<p>Imminent threat of danger Failure to comply will lead to death or very severe injuries.</p>	
	 WARNING
<p>Possible threat of danger Failure to comply can lead to death or very severe injuries.</p>	
	 CAUTION
<p>Dangerous situation Failure to comply can cause minor or moderate injuries.</p>	
	SAFETY INSTRUCTIONS
<p>Material damage Failure to comply can cause material damage.</p>	
	NOTICE
<p>Information Notes for better understanding and operation of the unit.</p>	

Symbol / sign	Meaning
▪	Listing of information.
	Action steps, which can be performed in any sequence.
1. 2.	Action steps, which must be performed in the prescribed sequence.
	Result of a listed action.

1.2 Intended use

This unit is intended to be used solely for commercial purposes, particularly in commercial kitchens.

This unit may only be used with suitable accessories and for the cooking of food.

It is forbidden to use the unit for purposes, which include the following:

- Washing dishes
- Storing supplies
- Drying cloths, paper or dishes
- Heating acids, alkaline solutions or other chemicals
- Heating preserved food
- Heating flammable liquids
- Heating rooms
- Cleaning air filters

This unit is certified in the following:



1.3 Warranty

The warranty is void and safety is no longer assured in the event of:

- Modifications or technical changes to the unit,
- Improper use,
- Incorrect startup, operation or maintenance of the unit,
- Problems resulting from failure to observe these instructions.

2 Safety information

The operator must be familiar with regional regulations and observe them.

Operation

During operation, the following group of individuals must be supervised by an individual who is responsible for safety:

- Individuals with physical, sensory, or mental handicaps, or who lack the knowledge and experience to operate the unit properly.

The supervising individual must be familiar with the unit and the risks associated with it.

Hot surfaces

Risk of burns from hot surfaces

- Protect arms and hands by wearing suitable protective gloves.
- Allow surfaces to cool prior to cleaning.
- Remove hot cookware only with suitable protective gloves or potholders.
- Remove containers and baking sheets only with suitable protective gloves or potholders.

Hot liquids

Risk of burns from hot liquids

- Protect arms and hands by wearing suitable protective gloves.
- Remove, transport and empty containers carefully.

Risk of chemical burns from evaporating cleaners

- Follow the instructions of the cleaning agent manufacturer.
- Allow the cooking so to clean to a temperature below 60°C (140°F) and then clean.

Risk of burns from steam

- Protect arms and hands by wearing protective gloves.
- Do not hold hands in front of the extractor hood.
- First open the cooking zone door slightly and allow the steam to escape. Then open the cooking zone door completely.
- Dry unit completely after cleaning it.

Defective unit

Risk of injury from a defective unit

- Disconnect a defective unit from the electric mains.

- Do not operate a defective unit.
- Allow only an authorized technician to repair the unit.

Fire prevention

Risk of fire from dirt and grease deposits

- Clean the unit when finished using it.
- Do not use the unit as a deep fat fryer.
- Do not store any combustible objects or plastic containers in the cooking zone.

Firefighting

- In the event of a fire, disconnect the unit from the electric mains.
- Use a Fire Class F fire extinguisher, never water, to extinguish grease fires. Other fires, for instance, can be extinguished with fire extinguishers suitable for Fire Classes A, B, C, CO₂ fire extinguishers or extinguishing media suitable for the fire class confronted.

Unit on casters

Risk of injury from a unit on casters

- Move the unit only for cleaning or maintenance.
- Lock casters during operation.
- Only move an empty unit.

Risk of electric shock from live components

- Security electric power cable to the wall at the installation location by means of a chain as strain relief.

Improper cleaning

Risk of chemical burns from cleaning agent

- Follow the instructions of the cleaning agent manufacturer.
- Take appropriate protective measures when handling aggressive cleaning agents.

Risk of falling on smooth floors

- Keep the floor in front of the unit clean and dry.

Risk of injury from improper cleaning

- Clean the cooking zone carefully. The cooking zone sensor protrudes into the cooking zone.

Risk of physical damage from improper cleaning

- Clean the unit after using it.
- Do not clean the unit with a high-pressure cleaner.
- Do not clean the housing with highly abrasive or chemically aggressive cleaning agents.
- Do not clean the housing with highly abrasive sponges.
- Follow the instructions of the cleaning agent manufacturer.
- Do not cool shock the unit by cooling it abruptly.
- Clean the cooking zone carefully. The cooking zone sensor protrudes into the cooking zone.
- Do not use any bleaching or chlorine-containing cleaners.
- Remove rust spots with an abrasive.
- Keep the unit free of calcium deposits.

Health risk from insufficient hygiene

Hygiene

Health risk from insufficient hygiene

- Observe applicable regional hygiene regulations.

Core temperature measurement

Risk of injury from overheated core temperature sensor

- Do not heat the core temperature sensor over an open flame.

Improper use

Risk of physical damage from improper use

- Use only original accessories.
- Train operators regularly.
- Do not heat food warmer plates or tins of preserved food.
- Do not cover air inlet and outlet openings.
- Do not operate the unit at temperatures below 4°C (39°F).
- Remove the core temperature sensor before the cooked food is removed.
- Insert the core temperature sensor back into the holder after use.

3 Description of the unit

3.1 Overview of the unit

3.1.1 Countertop unit

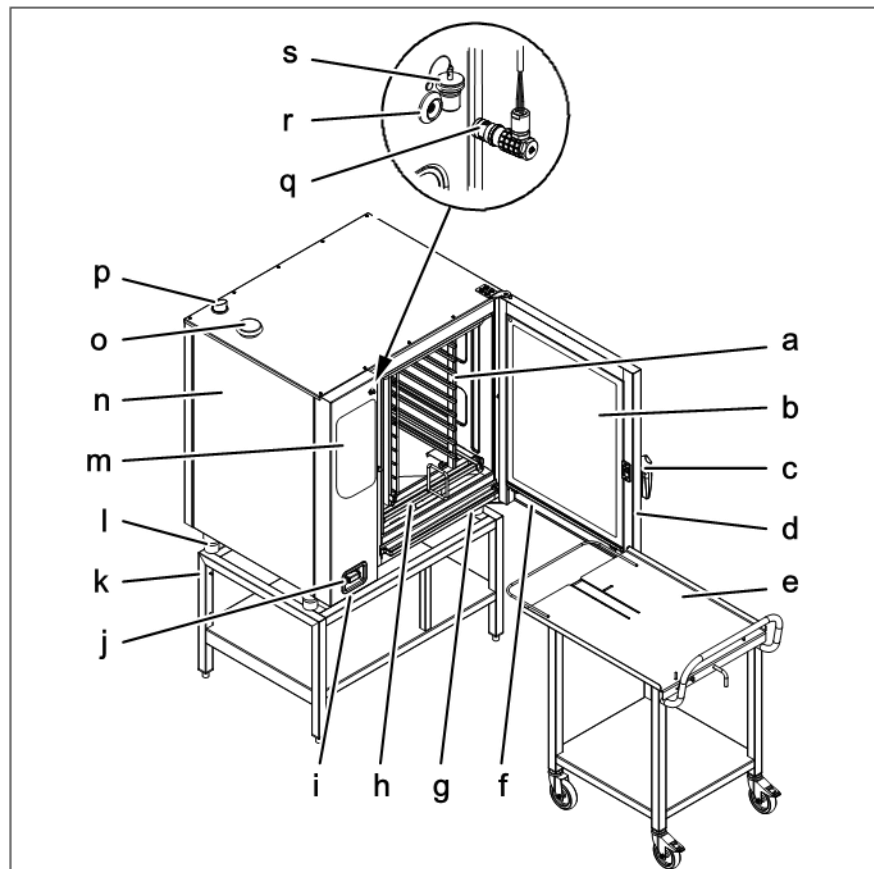

FlexFusion with tray rack trolley

a	Tray rack	k	Base frame (optional)
b	Insulated window	l	Equipment foot
c	Door handle	m	Operating control
d	Cooking zone door	n	Housing
e	Tray rack trolley (optional)	o	Air intake connection fitting
f	Steam drain channel, door	p	Steam outlet connection fitting
g	Steam drain channel, unit	q	Core temperature sensor (optional)

h	Guide rail for tray rack (optional)	r	Connection (optional)
i	USB port (covered)	s	Protective cap (optional)
j	Hand shower		

3.1.2 Floor-standing unit

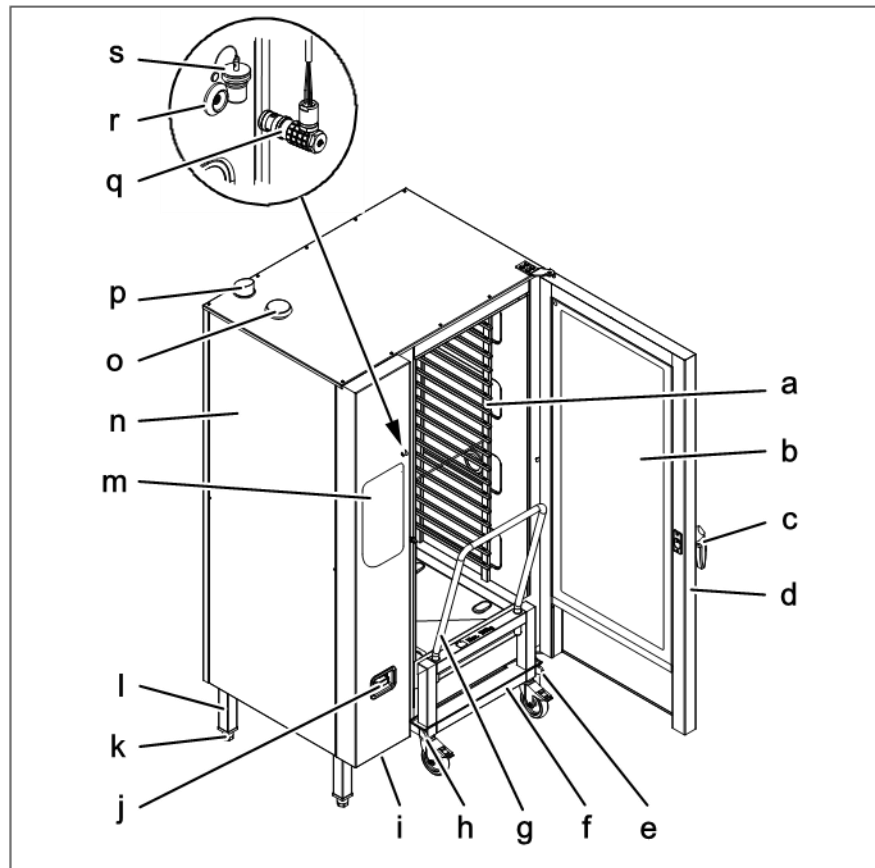

FlexFusion with tray trolley

a	Tray rack	k	Equipment leg
b	Insulated window	l	Equipment foot
c	Door handle	m	Operating control
d	Cooking zone door	n	Housing
e	Guide rail (right)	o	Air intake connection fitting
f	Tray trolley	p	Steam outlet connection fitting
g	Push handle	q	Core temperature sensor

			(optional)
h	Guide rail (left)	r	Connection (optional)
i	USB port (covered)	s	Protective cap (optional)
j	Hand shower		

3.2 Features

3.2.1 Characteristics

- 4-point core temperature sensor
- Sous-vide core temperature sensor or a second 4-point core temperature sensor (optional)
- Hand shower
- Cooking zone door with hygienic glazing
- Single-stage door latch
- Two-stage door latch (optional); this feature is standard on size 20 units
- Power optimizing system (optional)
- Ethernet connection (optional)
- Cooking zone door hinged at right
- Cooking zone door hinged at left (optional), not on size 20 floor-standing units
- WaveClean
- Barcode scanner (optional)
- Steam Exhaust System (SES)

3.2.2 Operating modes

Manual cooking

In the manual cooking mode, individual cooking programs and equipment functions can be actuated directly. The various cooking modes and equipment functions can be modified individually.

Automatic cooking (autoChef)

In the automatic cooking mode, stored cooking programs can be actuated and adapted as necessary.

3.2.3 Types of cooking

Steaming

Steaming is a cooking mode where the food to be cooked is cooked gently in steam in a temperature range of 30°C (86°F) to 130°C (266°F).

Combisteaming

Combisteaming is a cooking mode that can be used to cook large roasts, casseroles and baked goods in a temperature range of 30°C (86°F) to 250°C (482°F).

Hot air

Hot air is a cooking mode where the food to be cooked is cooked without additional moisture in a temperature range of 30°C (86°F) to 300°C (572°F).

Perfection (regeneration)

Perfection is a cooking mode that can be used to prepare cooled cooked food quickly in a temperature range of 30°C (86°F) to 150°C (302°F) and then keep it warm.

Delta-T cooking

Delta-T cooking is a cooking mode where the cooking temperature depends on the core temperature of the food being cooked.

The cooking temperature is always higher than the current core temperature by the set value (Delta-T value, cooking temperature difference). The resulting cooking time is longer than with other cooking modes.

Delta-T cooking is especially well-suited for general cooking. The food being cooked remains tender and juicy with little weight loss.

Low-temperature cooking

Low-temperature cooking is a cooking mode where the food to be cooked is cooked in an especially gentle manner in a temperature range of 30°C (86°F) to 100°C (212°F).

The cooking time is considerably longer than at higher temperatures, but no supervision is required and the cooking time can be extended considerably without any loss in quality.

The food being cooked remains tender and juicy with little weight loss.

Baking

Baking is a cooking mode where the food to be cooked is cooked and browned by hot air in a temperature range of 30°C (86°F) to 220°C (248°F); this opens up the texture of the food. Humidification and an associated idle time may precede baking.

3.2.4 Expanded cooking functions

Expanded cooking functions can be used to modify individual cooking steps for the particular food being cooked.

The following expanded cooking functions are available:

PerfectHold

PerfectHold is a cooking function where the prepared food is held in the unit in a temperature range of 50°C (122°F) to 100°C (212°F) after the actual cooking process until it is ready to be served.

Ready2Cook (preheating)

For many cooking programs such as baking, for instance, the correct starting temperature is important.

With Ready2Cook, the cooking zone can automatically be heated or cooled to the correct starting temperature.

Start-time preselection

 CAUTION
When using the start time delay, temperatures that promote the growth of harmful microorganisms on the food being cooked can occur in the cooking zone. Observe food processing regulations.

The start time delay can be used to set a waiting period until the program starts.

In this way, bottlenecks in production and preparation can be avoided.

The prepared food can be loaded into the unit and the desired cooking program selected.

Steam Exhaust System (SES)

This function is activated by default for all cooking programs that have a cooking time longer than 6 minutes.

The Steam Exhaust System (SES) is activated automatically shortly before the end of cooking.

After the cooking time, the Steam Exhaust System (SES) extracts the steam from the cooking zone. It is then possible to open the cooking zone door without risk of injury.

RackControl

With the expanded cooking function RackControl, different foods such as potatoes, cauliflower, peas, carrots and meat can be cooked simultaneously for different times.

RackControl monitors the various cooking times in one process. When one cooking time has elapsed, a signal sounds and the food being cooked can be removed. RackControl is ideal for rolling cooking.

FamilyMix

With the expanded cooking function FamilyMix, the appropriate cooking programs are displayed in the *Automatic cooking (autoChef)* menu for the currently set cooking mode. The cooking programs displayed have the same cooking climate and an identical or shorter cooking time. Tapping the individual suggestions transfers the cooking times for the individual products to the RackControl function and these can then be started when desired during the cooking process.

Manual humidification

Manual humidification allows the cooking zone humidity to be increased during operation.

Manual humidification can be used only in the hot air and Delta-T hot air cooking modes.

Idle time

With the idle time expanded cooking function, a cooking step can be inserted during which the heating and the fans are programmed to switch off for a certain period of time.

3.2.5 Core temperature measurement

When using core temperature measurement, the temperature inside the food being cooked is measured by means of a sensor.

The core temperature sensor measures the core temperature at one or more points, depending on the version. The temperature measured at the coldest spot is used to control the cooking process.

As soon as the target core temperature has been reached, the cooking process is ended automatically or, in the case of a multi-step cooking program, advances to the next cooking step.

The use of core temperature measurement offers the following benefits:

- Reduced energy and water consumption
- No overcooking
- Less weight lost by the food being cooked

The following core temperature sensors are available:

- 4-point core temperature sensor

or

- a second 4-point core temperature sensor (optional)

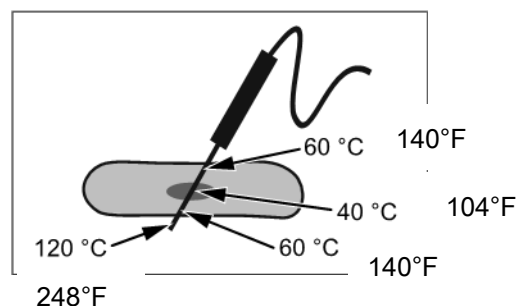

Core temperature measurement with a 4-point core temperature sensor

or

- Sous-vide core temperature sensor (optional)

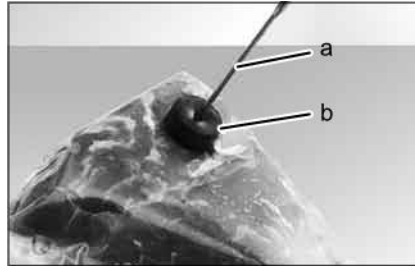

Core temperature measurement with sous-vide core temperature sensor

a	Sous-vide core temperature sensor	b	Foam rubber
---	-----------------------------------	---	-------------

3.2.6 Barcode scanner

The barcode scanner scans the barcode on the packaging of the food to be cooked and transmits it to the unit. The unit then searches for the appropriate cooking program for the food to be cooked. If several appropriate cooking programs are found, they are displayed in a list.

A prerequisite is that the cooking programs are assigned a corresponding identification when saved.

3.2.7 USB port

The unit is equipped with a USB port (USB 2.0).

HACCP logs can be exported via the USB port.

A wireless or corded barcode scanner (optional) can be connected to the USB port.

3.2.8 HACCP logging

All cooking steps are recorded with a log number in the HACCP log.

The data are exported via the USB port.

3.2.9 VideoAssist

VideoAssist can be used to display videos with additional explanations regarding operation.

3.2.10 WaveClean automatic cleaning

With WaveClean automatic cleaning, the cooking zone is cleaned with the aid of a cleaning cartridge intended specifically for the program and then rinsed clean.

3.2.11 CombiDoctor (self-diagnostic program)

CombiDoctor uses a selectable self-diagnostic program to check the components used for climate control and cleaning.

3.3 Operating, control and display element functions

NOTICE

To see the operating and display elements, see next page.

Symbol	Operating and display element	Function
	<i>On Off</i> button	<ul style="list-style-type: none"> ▪ "I" switches on the unit ▪ "O" switches off the unit
	"Automatic cooking" button	<ul style="list-style-type: none"> ▪ Opens the <i>Automatic cooking</i> menu for selection of programs
	"Manual cooking" button	<ul style="list-style-type: none"> ▪ Opens the <i>Manual cooking</i> menu for selection of the cooking modes
	"Equipment functions" button	<ul style="list-style-type: none"> ▪ Opens the <i>Equipment function</i> menu for selection of cleaning and settings

Symbol	Operating and display element	Function
	<i>Language selection</i> button	<ul style="list-style-type: none"> Indicates that the operating language for the unit can be selected here by tapping a country's flag <p>Selection and the number of selectable languages can be specified in the <i>Equipment functions</i> menu in the settings field "Languages".</p>
	<i>Back</i> button	<ul style="list-style-type: none"> Tapping once returns the user to the previous menu Tapping twice returns the user directly to the main menu
	<i>FlexiHelp</i> button	<ul style="list-style-type: none"> Displays the help texts for the active menu or window.

3.4 Application

3.4.1 Plate capacity during regeneration

Cooking time and cooking temperature depend on the number of plates.

Version	Plate diameter					
	26 cm (10.24 in)		28 cm (11.02 in)		32 cm (12.1 in)	
6.15	30	(11.81)	24	(9.45)	22	(8.66)
6.21	30	(11.81)	24	(9.45)	22	(8.66)
10.15	50	(19.69)	40	(15.75)	40	(15.75)
10.21	50	(19.69)	40	(15.75)	40	(15.75)

Version	Plate diameter		
	26 cm (10.24 in)	28 cm (11.02 in)	32 cm (12.1 in)
20.15	100 (39.37)	80 (31.5)	80 (31.5)
20.21	120 (47.24)	120 (47.24)	80 (31.5)
on	1/1 GN grate		Tray rack or tray trolley

3.4.2 Loading capacity

Tray rack trolley and tray trolley

Version	Max. per tray		Max. per unit	
	(kg)	(lbs)	(kg)	(lbs)
6.15	15	33	50	110
6.21	15	33	50	110
10.15	15	33	80	176
10.21	15	33	80	176
20.15	15	33	150	330
20.21	15	33	150	330

3.4.3 Temperature standard setting

The setting range for the cooking zone temperature depends on the type of cooking.

Type of cooking	Standard value		Setting range		Change increments (°C)
	(°C)	(°F)	(°C)	(°F)	
Steaming	100	212	0 - 99	86 - 320	1-steps
Combisteam	150	302	30 - 250	86 - 482	1-steps
Hot air	180	356	30 - 250	86 - 482	1-steps
Regeneration	50	122	30 - 150	86 - 302	1-steps

3.4.4 Core temperature standard setting

The setting range for the core temperature depends on the type of cooking.

Type of cooking	Standard value		Setting range		Change increments (°C)
	(°C)	(°F)	(°C)	(°F)	
Steaming	70	158	0 - 99	32-210	1-steps
Combisteaming	70	158	0 - 99	32-210	1-steps
Hot air	70	158	0 - 99	32-210	1-steps
Regeneration	50	158	20 - 99	68-210	1-steps

3.5 Chef's Touch equipment controls

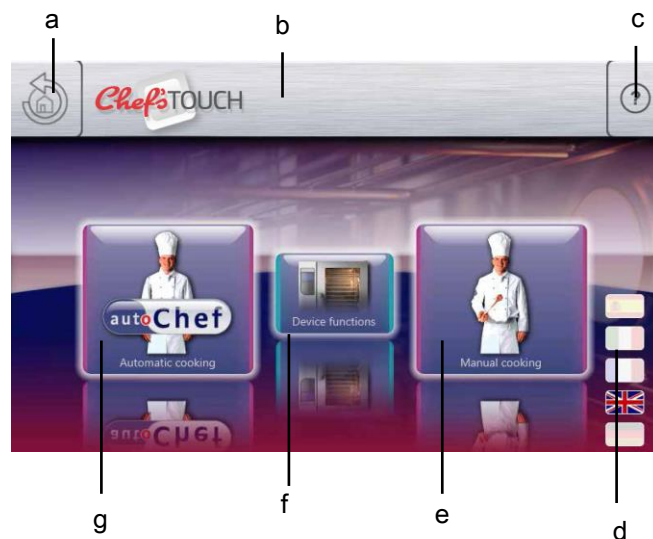

Main menu

a	Back button	e	"Manual cooking" button
b	Information bar	f	"Equipment functions" button
c	FlexiHelp button	g	"Automatic cooking" button
d	Language selection button		

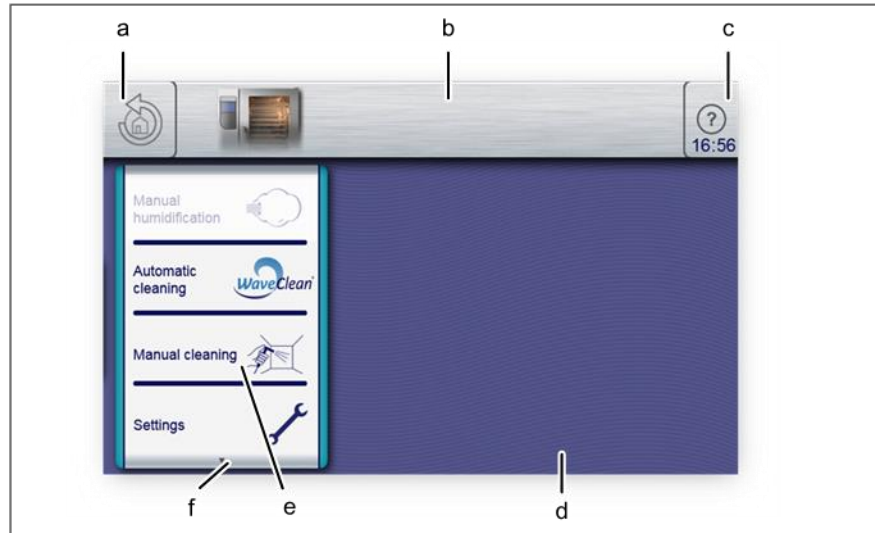

Equipment functions menu

a	Back button	d	Window
b	Information bar	e	Clean touchscreen field
c	FlexiHelp button	f	Next page arrow symbol

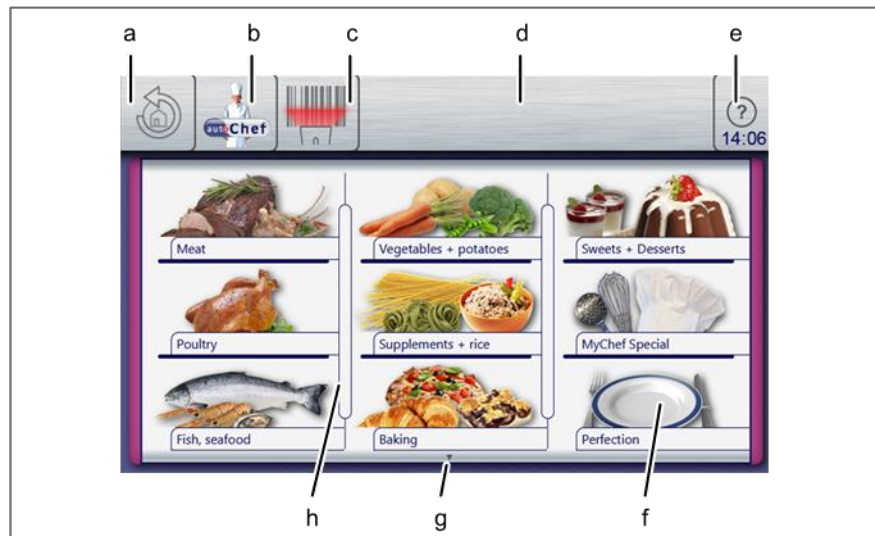

Automatic cooking, AutoChef menu

a	Back button	e	FlexiHelp button
b	"autoChef" button	f	"Perfection" field
c	Barcode scanner button	g	Next page arrow symbol
d	Information bar	h	Separating bar

3

Description of the unit

Chef's Touch equipment controls

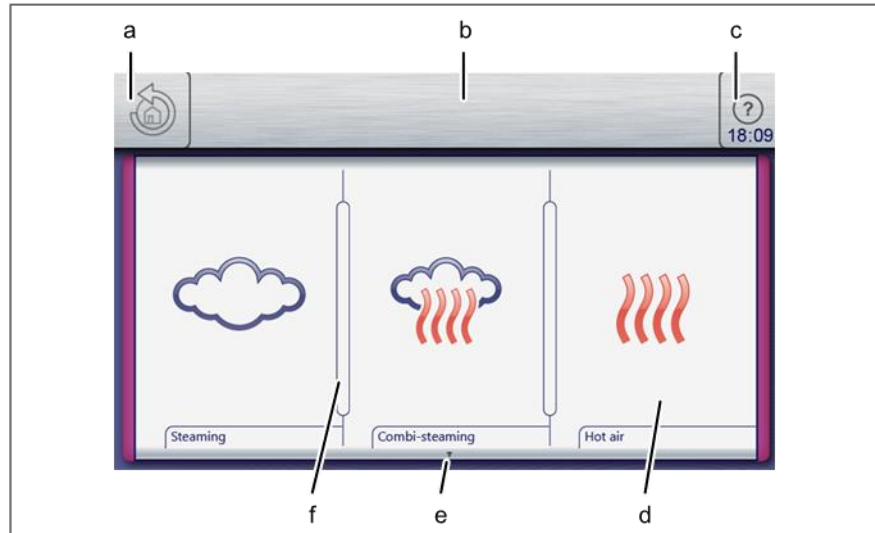

Manual cooking menu

a	Back button	d	"Hot air" field
b	Information bar	e	Next page arrow symbol
c	FlexiHelp button	f	Separating bar

3.5.1 Touchscreen operation

NOTICE

The touchscreen can be operated with latex gloves.

Tapping on the touchscreen executes commands that operate the unit.

Action	Function
Tap	To select or activate display elements such as buttons, fields, tabs.
Tap twice	To execute special functions by tapping a button twice rapidly
Wiping gesture	To change the page or the set value by moving up, down, to the left or to the right with the fingertip after first tapping and then maintaining contact with the field to be changed.

3.5.2 Display elements

The following table lists the basic display elements of the unit's control system with examples.

Display element	Function
Information bar	<p>The information bar is the uppermost bar on the touchscreen and visible at all times.</p> <p>The information bar is used to display current information, for instance, categories or cooking programs.</p>
Menu	<p>Menus have a coloured border that identifies the associated subject.</p> <ul style="list-style-type: none"> ▪ Blue for equipment functions <p>and</p> <ul style="list-style-type: none"> ▪ Violet for cooking functions. <p>Menus frequently contain vertical separating bars to simplify wiping gestures.</p> <p>Menus represent central entry points and provide an overview of the selectable functions and submenus.</p>
Window	<p>Windows have a coloured border and are opened from menus or higher-level windows.</p> <p>Functions are executed and settings displayed in windows.</p> <p>Depending on the function, there are several window types, for instance, Find.</p>
Field	<p>Fields are areas in windows or menus defined by separating bars.</p> <p>Tapping fields opens functions and settings.</p>
Button	<p>Buttons are areas enclosed by borders in windows or menus.</p> <p>Tapping buttons confirms settings. Buttons control functions and are used to navigate in</p>

Display element	Function
	menus and windows.
Page	<p>Pages are the areas with content in windows and menus. Several pages can follow one another in sequence.</p> <p>An arrow symbol displays further pages. Changing to the next or the previous page is accomplished by wiping up or down.</p>
Tab	<p>A <i>blue</i> and a <i>green</i> tab are located on the left side of the touchscreen. The tabs are available only in the cooking step display.</p> <p>Tapping the tabs offers quick access to equipment functions and cooking program functions.</p>
Display	<p>Displays are information-containing areas in windows.</p> <p>Displays show entries and current information some of which may be operated by tapping.</p>
Symbol	<p>Symbols are graphical elements in windows and in the toolbar.</p> <p>Symbols indicate current states and possible functions some of which may be operated by tapping.</p>
Roller	<p>Rollers are areas where settings can be made by means of wiping gestures.</p>

4 Putting the unit into service

Requirement

- Any remaining packaging removed from the cooking zone
 - Protective film pulled off the housing
 - a) Clean the unit.
 - b) Enter the data on the nameplateNameplate [→ 80].
 - c) Switch on the unit and select the cooking program *Combisteam* in the "Manual cooking: menu.
 - d) Set the temperature to 200°C (392°F) Setting the cooking temperature [→ 46].
- ⇒ Operate the unit for 20 minutes.

5 Operating the unit

	NOTICE
	Explanatory video clips can be selected under VideoAssist by press the Help button.

5.1 Switching the unit on and off

5.1.1 Switching on

- a) Press "I" on the *On Off* button.
 - ⇒ The unit is now on
 - ⇒ The control system starts the power-on process automatically. The progress bar at the lower edge of the touchscreen displays the status of the process.
 - ⇒ The main menu appears after 1 minute and the unit is ready for use.

5.1.2 Switching off

	NOTICE
	Fans may continue to run for cooling; the unit's control system is disconnected from power.

- a) Press "O" on the *On Off* button.
 - ⇒ The unit is now off.

5.2 Opening and closing the cooking zone door

NOTICE

The single-stage door latch is standard on sizes 6 and 10.

NOTICE

The two-stage door latch is standard on size 20, and optional on sizes 6 and 10.

5.2.1 Opening the single-stage door latch

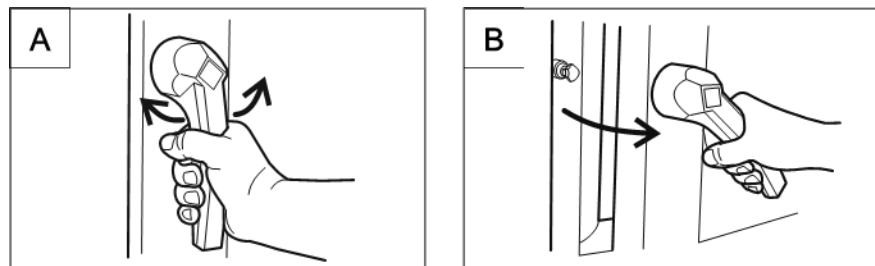

Opening the single-stage door latch

- a) Rotate the door handle anti-clockwise or clockwise.
 - ⇒ The cooking zone door opens.

NOTICE

If the door handle is released, it returns automatically to its initial position.

- a) Open the cooking zone door completely.

5.2.2 Closing the single stage door latch

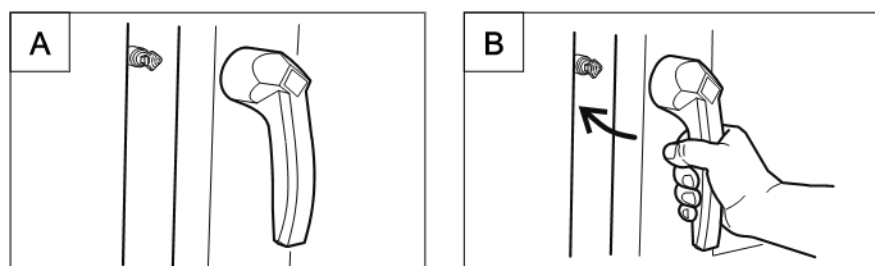

Closing the single stage door latch

- Door handle in initial position

 - a) Close the cooking zone door with pressure.

Requirement

⇒ The cooking zone door is closed.

5.2.3 Opening the two-stage door latch

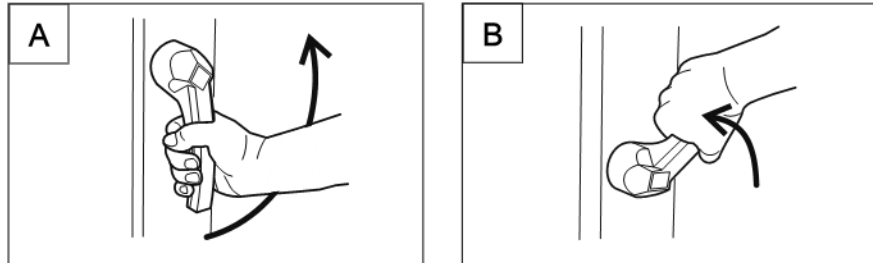

Opening the two-stage door latch

NOTICE

On size 6 and size 10, first rotate the door handle anti-clockwise.

- a) Rotate the door handle to a horizontal position.
 - ⇒ The cooking zone door opens, but is still held.
- b) Continue rotating the door handle upwards.
 - ⇒ The cooking zone door is no longer held.

NOTICE

If the door handle is released, it returns automatically to its initial position.

- a) Open the cooking zone door completely.

5.2.4 Closing the two-stage door latch

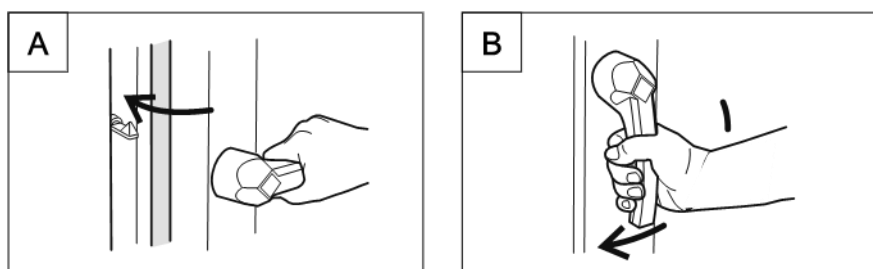



Closing the two-stage door latch

Requirement

- Door handle in initial horizontal position
- a) Close the cooking zone door with pressure.
 - ⇒ The cooking zone door latches.
 - b) Rotate the door handle downwards.
 - ⇒ The cooking zone door is closed.

5.3 Loading and emptying the unit

	<p> WARNING</p> <p>Risk of burns from hot liquid</p> <ul style="list-style-type: none"> a) Never insert a food-carrying tray with cooking liquid above eye level. b) Use only suitable trays to hold food. The food-containing trays must rest securely on the support brackets. c) Always insert the food-containing trays into the U-rails.
	<p> CAUTION</p> <p>Risk of physical damage and personnel injury from exceeding the loading capacity</p> <ul style="list-style-type: none"> a) Do not exceed the maximum loading capacity.
	<p> CAUTION</p> <p>To not use bent or damaged support racks.</p>

5.3.1 Loading and emptying

Loading

- a) Open the cooking zone door.
- b) Insert food-containing trays into the support racks.
- c) Close the cooking zone door.
- d) Start the cooking process.

Emptying

- a) Open the cooking zone door.
- b) Remove the food-containing trays.
- c) Remove all food residues from the drain screen.
- d) Leave the cooking zone door slightly ajar.
 - ⇒ This extends the service life of the door seal.
 - ⇒ No moisture builds up in the cooking zone.

5.3.2 Loading and emptying with a tray rack trolley

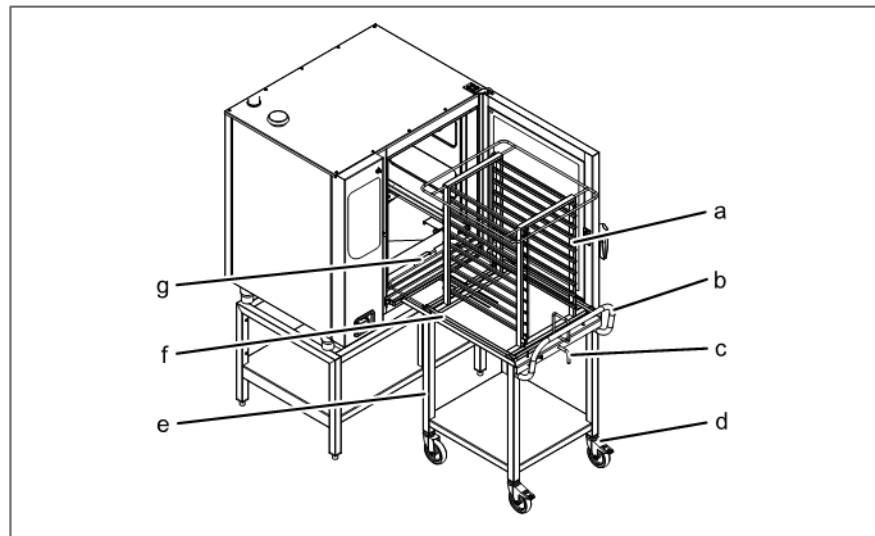

Loading and emptying with a tray rack trolley

a	Tray rack	e	Tray rack trolley
b	Push handle	f	Tray rack support plate
c	Lever	g	Guide rail
d	Locking casters		

Loading with a tray rack trolley

Requirement

- Remove support racks and place guide rails on pins.
 - Food-containing trays resting securely on the tray rack
- a) Open the cooking zone door.
 - b) Rotate the lever on the tray rack trolley.
 - ⇒ The tray rack is secured to prevent its rolling down.
 - ⇒ Check that the tray rack is locked in place by pulling on it slightly.
 - c) Load the tray rack.
 - d) Position the tray rack trolley at the unit.
 - ⇒ Lock the casters to prevent the trolley's rolling away.
 - e) Rotate the lever.
 - ⇒ The tray rack is now free to move.
 - f) Insert the tray rack completely until the rollers rest in the openings in the guide rail.
 - g) Retract the tray rack support plate and secure in place with the lever.
 - h) Move the tray rack trolley away from the unit.
 - i) Close the cooking zone door.

j) Start the cooking process.

Emptying with a tray rack trolley

- a) Open the cooking zone door.
- b) Position the tray rack trolley at the unit.
 - ⇒ Lock the casters to prevent the trolley's rolling away.
- c) Insert the tray rack support plate and secure the tray rack on the plate.
- d) Pull the tray rack onto the tray rack trolley and secure in place.
- e) Release the locking casters and move the tray rack trolley away from the unit.
- f) Remove all food residues from the drain screen.
- g) Leave the cooking zone door slightly ajar.
 - ⇒ This extends the service life of the door seal.
 - ⇒ No moisture builds up in the cooking zone.

5.3.3 Loading and emptying with a tray trolley

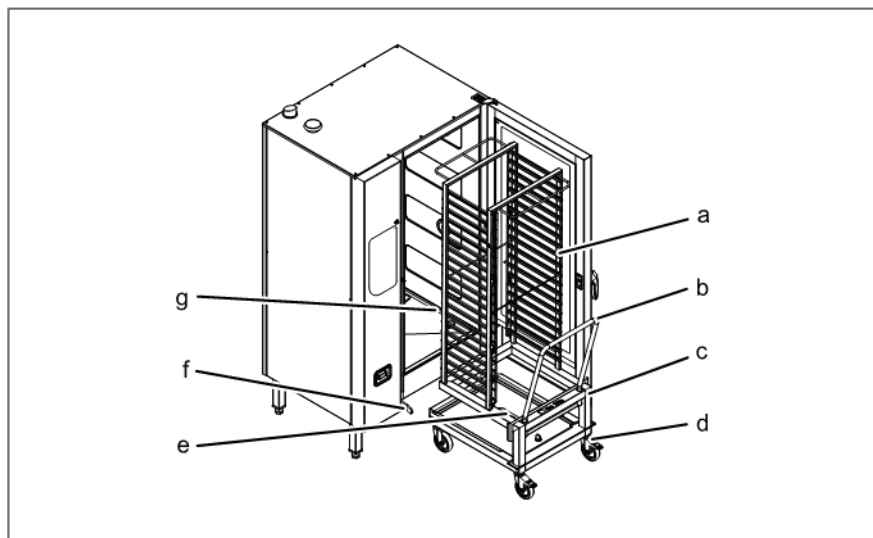

Loading and emptying with a tray trolley

a	Tray rack	e	Cleaning cartridge holder
b	Push handle	f	Guide rail (left)
c	Tray trolley	g	Guide rail (right)
d	Locking casters		

Loading with a tray trolley

- Food-containing trays resting securely on the tray trolley
- a) Load the tray trolley.

Requirement

- b) Insert the tray trolley completely.
- c) Pull the push handle out of the tray trolley.
- d) Close the cooking zone door.
- e) Start the cooking process.

Emptying with a tray trolley

- a) Open the cooking zone door.
- b) Insert the push handle into the tray trolley.
- c) Retract the tray trolley.
- d) Remove all food residues from the drain screen.
- e) Leave the cooking zone door slightly ajar.
 - ⇒ This extends the service life of the door seal.
 - ⇒ No moisture builds up in the cooking zone.

5.4 Using the core temperature sensor

	<p>⚠ WARNING</p> <p>Risk of injury from a bursting core temperature sensor</p> <p>a) The core temperature sensor can burst as the result of overheating of the measuring tip.</p> <p>b) Never heat a core temperature sensor with a cigarette lighter or other heat source.</p>
	<p>NOTICE</p> <p>Measuring the core temperature is recommended for all types of cooking to achieve an optimal result.</p> <p>The unit has a core temperature sensor in the cooking zone and can be equipped with an optional connection for an external core temperature sensor.</p>

5.4.1 Measuring with a 4-point core temperature sensor

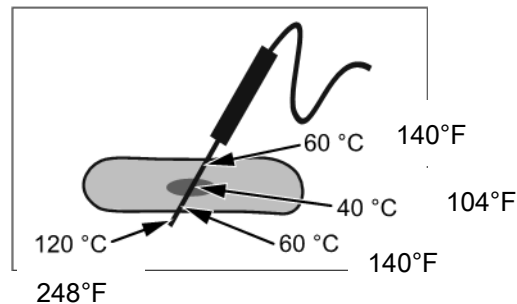

Core temperature sensor with four measuring points

- Completely insert the core temperature sensor into the food to be cooked.
- Insert the core temperature sensor into the thickest section of the food to be cooked.
- When cooking food with a bone, insert the core temperature sensor close to the bone.
- When cooking longer pieces of food, insert the core temperature sensor across the food to avoid a hole in the centre of the slice.
- When cooking fowl, insert the core temperature sensor into the inside of the leg.

5.4.2 Measuring with a sous-vide core temperature sensor

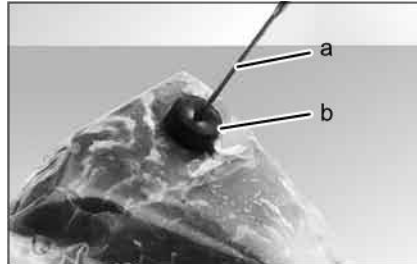

Sous-vide core temperature sensor with sous-vide pads

- a) Attach foam rubber or expanded rubber sous-vide pads to the vacuum-packed food to be cooked.
- b) Always insert the sous-vide core temperature sensor through the sous-vide pads completely into the food to be cooked.
- c) Insert the sous-vide core temperature sensor into the thickest section of the food to be cooked.
- d) When cooking food with a bone, insert the sous-vide core temperature sensor close to the bone.
- e) When cooking longer pieces of food, insert the sous-vide core temperature sensor across the food to avoid a hole in the centre of the slice.
- f) When cooking fowl, insert the sous-vide core temperature sensor into the inside of the leg.

5.4.3 Measuring the core temperature when cooking frozen food

NOTICE

When cooking frozen food, measuring with a sous-vide core temperature sensor is not possible.

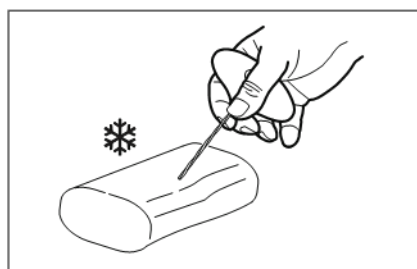

Drilling a hole with a hand drill

1. Use a hand drill to make a hole for inserting the sensor.
2. Place the food to be cooked on the baking sheet or into the cooking pan.
3. Place the cooking sheet or cooking pan into the unit.
4. Insert the core temperature sensor into the food being cooked.

5.5 Making the basic settings

The basic settings for operation can be displayed and changed by entering the password "111".

5.5.1 Opening the Setting menu

Requirement

- The unit is on
- The main menu is displayed
 - a) Tap the "Equipment functions" button.
 - ⇒ The *Equipment functions* menu is displayed.
 - b) Tap the "Settings" field.
 - ⇒ The *PIN* window opens.
 - c) Enter the password.
 - d) Tap the *Confirm* button.
 - ⇒ The *Equipment settings* menu is displayed.
- ⇒ The basic settings can be changed.

The unit has default settings when it is delivered.

These fields can be modified in the "Setting" window:

- Equipment information
- Export HACCP
- Settings for favourites
- CombiDoctor
- Select language
- Installation height
- Audio settings
- Select signal tones
- Date and time
- Select the cook book
- Import the manufacturer's cookbook
- Lock the cookbook

- Import HansDampf programs
- Software update
- Import additional content
- Export log data
- Setting units

These fields are switched on or off in the "Setting" window:

- QualityControl on or off
- Eco display on or off
- Inhibit operation on or off

5.5.2 Retrieving equipment information

	<i>NOTICE</i>
	The equipment information contains data on the software and hardware version, the serial number of the unit and contact data.

Requirement

- The *Setting* menu is displayed
- a) Tap the "Equipment information" field.
 - ⇒ The *Equipment information* window is displayed.
 - ⇒ Equipment information can now be read.

5.5.3 Setting the date and time

NOTICE
Observe the displayed date and time format carefully. If values are invalid, the entry is not accepted.



Date and time setting window

Requirement

- The *Settings* menu is displayed
- a) Tap the "Set date and time" field.
 - ⇒ The *Setting* window opens.
 - ⇒ The *Keypad* opens.
- b) Enter the date and time.
- c) Tap the Confirm button.
 - ⇒ The *Keypad* closes.
- ⇒ The date and time are set.

5.5.4 Presetting the language selection

	NOTICE
	A maximum of 5 languages can be specified for language selection in the main menu.
	NOTICE
	Highlighted fields represent the specified languages. Fields that are not highlighted are languages that have not been specified.
	NOTICE
	The currently set language cannot be deselected.



Language setting window

Requirement

- The *Setting* menu is displayed
- a) Tap the "Select language" field.
 - ⇒ The *Languages* menu is displayed.
- b) Select or deselect the language by tapping the fields with the country's flag.
 - ⇒ The selected languages are displayed.
- c) Tap the "OK" button.
 - ⇒ Languages have been preset for language selection and are available in the main menu.

5.5.5 Activating and cancelling inhibit operation

5.5.5.1 Activating inhibit operation

Requirement

- The "Inhibit operation ON" function is activated in the *Setting* menu
- a) Tap and hold the centre of the information bar for 3 seconds.
 - ⇒ The FlexiHelp button disappears and the lock symbol appears in the information bar.
 - ⇒ The touchscreen is locked.

5.5.5.2 Cancelling inhibit operation



Unlock the main menu by entering the PIN

Requirement

- The touchscreen is locked
- a) Tap the lock symbol.
 - ⇒ The Keypad opens.
- b) Enter the password.
 - ⇒ Inhibit operation is cancelled by entering the password "369".
- ⇒ The lock symbol and the keypad disappear. The *FlexiHelp* button appears in the information bar and the touchscreen is unlocked.

5.6 Basic functions

5.6.1 Setting the cooking temperature

NOTICE

The temperature range differs, depending on the cooking mode. At a cooking temperature outside the allowed temperature range, the display turns red.

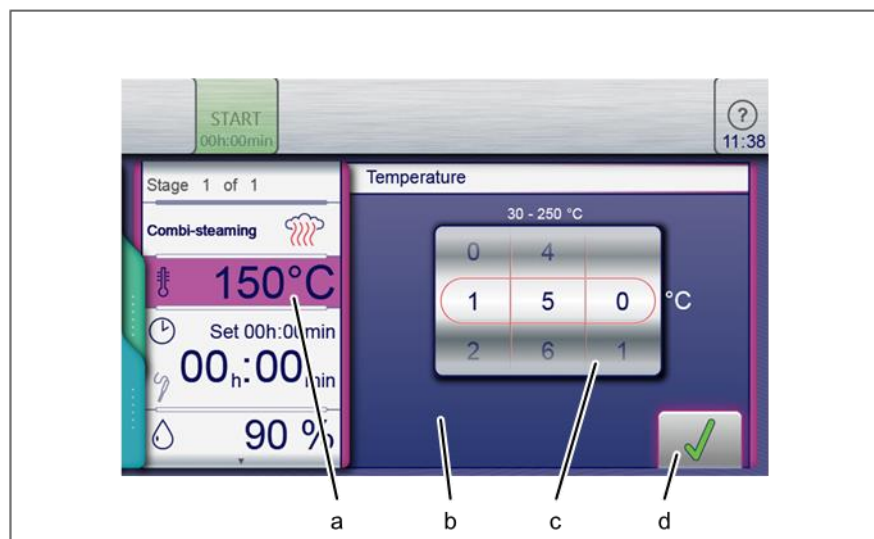

Cooking temperature setting window

a	Temperature field	c	Roller
b	Setting window	d	Confirm button

Requirement

- Cooking program selected
- a) Tap the *Cooking temperature* field.
 - ⇒ The *Setting* window is displayed.
- b) Tap the *Temperature* field.
- c) Using a wiping gesture, set the rollers to the desired temperature.
 - ⇒ Wipe up / down to increase / decrease the cooking temperature.
- d) Tap the *Confirm* button.
 - ⇒ The *Setting* window closes.
 - ⇒ The *Cooking mode* window displays the set cooking temperature.
- ⇒ The cooking temperature is set.

5.6.2 Setting the cooking time and continuous operation

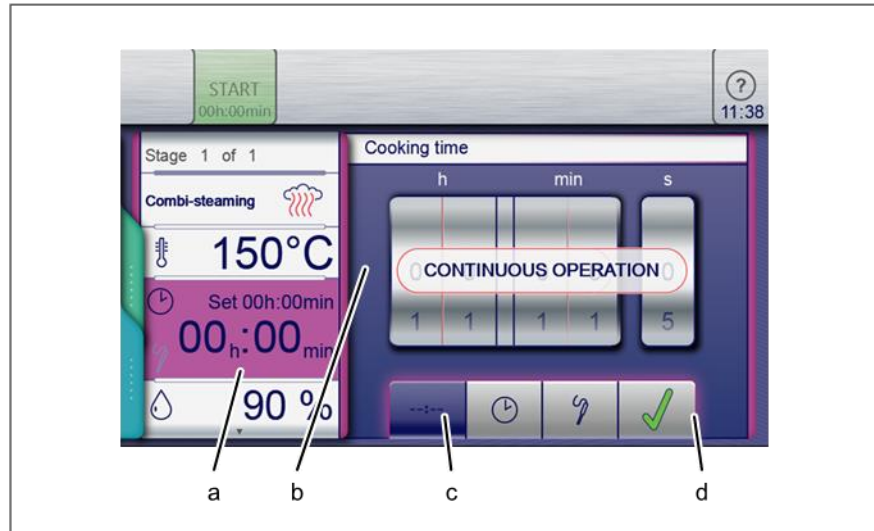

Setting the cooking time to continuous operation

a	Cooking time field	c	Continuous operation button
b	Setting window	d	Confirm button

Requirement

- Cooking program selected
- a) Tap the *Cooking time* field.
 - ⇒ The *Setting* window is displayed.
- b) Tap the *Continuous operation* button.
- c) Tap the *Confirm* button.
 - ⇒ The *Setting* window closes.
 - ⇒ The *Cooking mode* window displays the cooking time.
- ⇒ The cooking time is set to continuous operation and will end after 24 hours.

Setting the cooking time

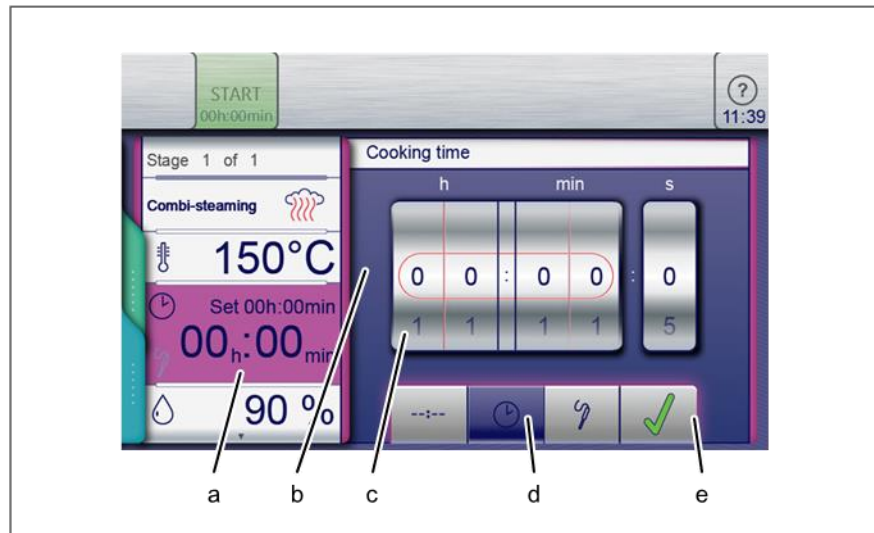

Setting the cooking time

a	Cooking time field	d	Cooking time button
b	Setting window	e	Confirm button
c	Roller		

Requirement

- Cooking program selected
- a) Tap the *Cooking time* field.
 - ⇒ The *Setting* window is displayed.
- b) Tap the *Cooking time* button.
- c) Using a wiping gesture, set the rollers to the desired temperature.
 - ⇒ Wipe up / down to increase / decrease the cooking time.
- d) Tap the *Confirm* button.
 - ⇒ The *Setting* window closes.
 - ⇒ The *Cooking mode* window displays the cooking time.
- ⇒ The cooking time is set.

5.6.3 Setting the core temperature

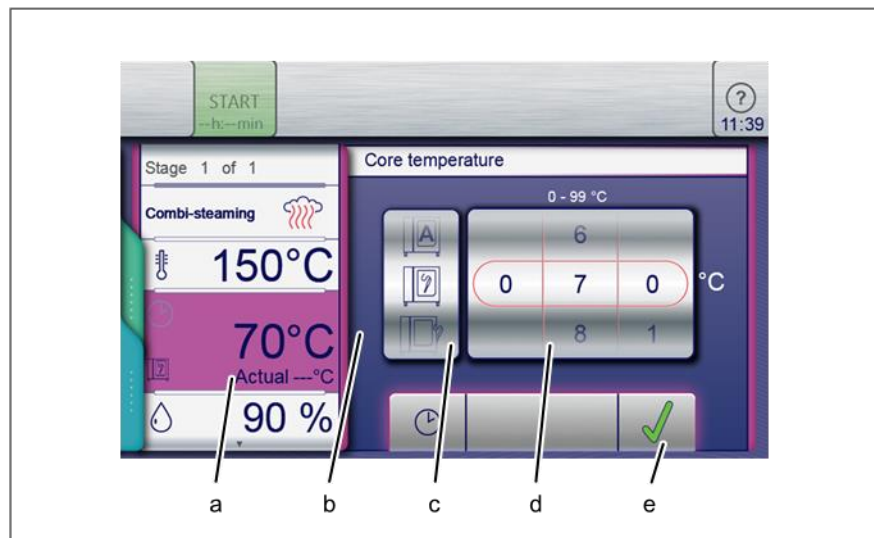

Core temperature setting window for internal and external display

a	Core temperature field	d	Temperature roller
b	Setting window	e	Confirm button
c	Core temperature sensor type roller		

Requirement

- Cooking program selected
- Cooking time set
- a) Tap the *Cooking time* field.
 - ⇒ The *Cooking time* setting window is displayed.
- b) Tap the *Core temperature* button.
 - ⇒ The *Core temperature* setting window is displayed.
- c) Using a wiping gesture, set the rollers to the desired temperature.
 - ⇒ Wipe up / down to increase / decrease the core temperature.
- d) Tap the *Confirm* button.
 - ⇒ The *Setting* window closes.
 - ⇒ The *Cooking time* field changes to the *Core temperature* field.

5.6.4 Setting the fan speed and direction of rotation

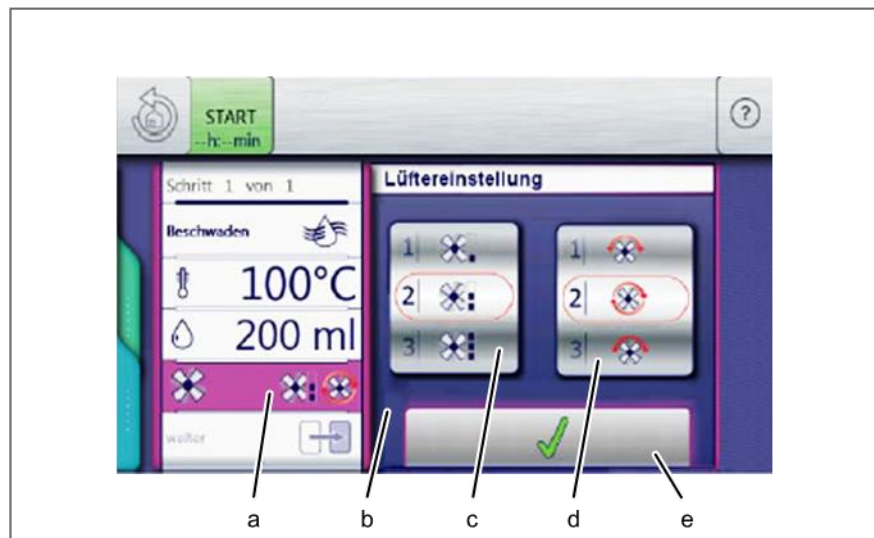

Setting the fan speed and direction of rotation

a	Fan setting field	d	Fan rotation direction roller
b	Setting window	e	Confirm button
c	Fan speed roller		

Requirement

➤ Cooking program selected

a) Tap the *Fan setting* field.

⇒ The Setting window opens.

b) Using a wiping gesture, set the *Fan speed* roller to the desired value.

c) Using a wiping gesture, set the *Fan rotation direction* roller to the desired value.

d) Tap the *Confirm* button.

⇒ The fan speed and fan rotation direction are set.

5.6.5 Inserting and removing a USB flash drive

Inserting a USB flash drive

Requirement

➤ USB flash drive with a minimum of 2 GB and maximum of 32 GB available storage capacity (not included with delivery)

➤ USB flash drive not write-protected

a) Insert the USB flash drive.

⇒ The USB flash drive is ready after at most 20 seconds.

Removing the USB flash drive

Requirement

- Exporting or importing of data completed
- a) Remove the USB flash drive.

5.6.6 Exporting the HACCP log

Requirement

- USB flash drive inserted
- User logged in with password under equipment settings
- a) Tap the "Export HACCP" field.
 - ⇒ The *Operating instructions* window opens.
- b) Tap the *Confirm* button.
 - ⇒ The HACCP log is exported to the USB flash drive.
 - ⇒ The *Confirm* window opens.
- c) Tap the *Confirm* button.
 - ⇒ the *Confirm* window closes.
 - ⇒ The HACCP log is exported to the USB flash drive.

5.7 Equipment functions

Various functions or settings can be selected in the "Equipment functions" menu.

5.7.1 Opening the Equipment function menu

NOTICE
All equipment functions can also be accessed from within a cooking program by tapping the <i>blue</i> tab.

Requirement

- The unit is on
- The main menu is displayed
- a) Tap the Equipment functions button.
 - ⇒ The Equipment functions menu is displayed.

5.8 Manual cooking

Cooking modes and other functions are available in the manual cooking mode. Selecting one of the components automatically creates a single-step cooking program.

5.8.1 Opening the Manual cooking menu

Requirement

- The unit is on
- The main menu is displayed
- a) Tap the "Manual cooking" button.
 - ⇒ The *Manual cooking* menu is displayed.

5.8.2 Creating a cooking program

Requirement

- The unit is on
- The *Manual cooking* menus is displayed
- Cooking mode selected
- a) Tap the *Cooking temperature* field.
 - ⇒ The *Setting* window is displayed.
- b) Using a wiping gesture, set the rollers to the desired value.
- c) Tap the *Confirm* button.
 - ⇒ The *Setting* window closes.
- d) Tap the *Cooking time* field.
 - ⇒ The *Setting* window is displayed.
- e) Tap the *Continuous operation* button or the *Cooking time* button or the *Core temperature* button.
- f) Using a wiping gesture, set the rollers to the desired value.
- g) Tap the *Confirm* button.
 - ⇒ The *Setting* window closes.
- h) Tap cooking zone humidity.
 - ⇒ The *Setting* window is displayed.
- i) Using a wiping gesture, set the roller to the desired value.
- j) Tap the *Confirm* button.
 - ⇒ The *Setting* window closes.
- k) Use a wiping gesture to change to the next page and make further settings.
- l) Tap the *Fan* field.
 - ⇒ The *Setting* window is displayed.
- m) Set the fan speed and direction of rotation.
- n) Using a wiping gesture, set the rollers to the desired value.
- o) Tap the *Confirm* button.
 - ⇒ The *Setting* window closes.
- p) Tap the *green* tab.
 - ⇒ The *green* tab opens.

- q) Save or start the cooking program.

5.9 User's own cooking programs

Cooking modes and other functions are available in the *Manual cooking* menu. Using these components, users can create their own programs.

5.9.1 Creating a cooking program

Requirement

- The *Manual cooking* menu opens
 - a) Tap the field for the desired cooking mode.
 - ⇒ The first step of the cooking program is created.
 - ⇒ The cooking program step display reads "Step 1 of 1".
 - b) Modify the desired settings for the first step.
 - ⇒ The first step of the cooking program has been created.

Adding cooking program steps

NOTICE
Up to 20 steps can be added to a cooking program.

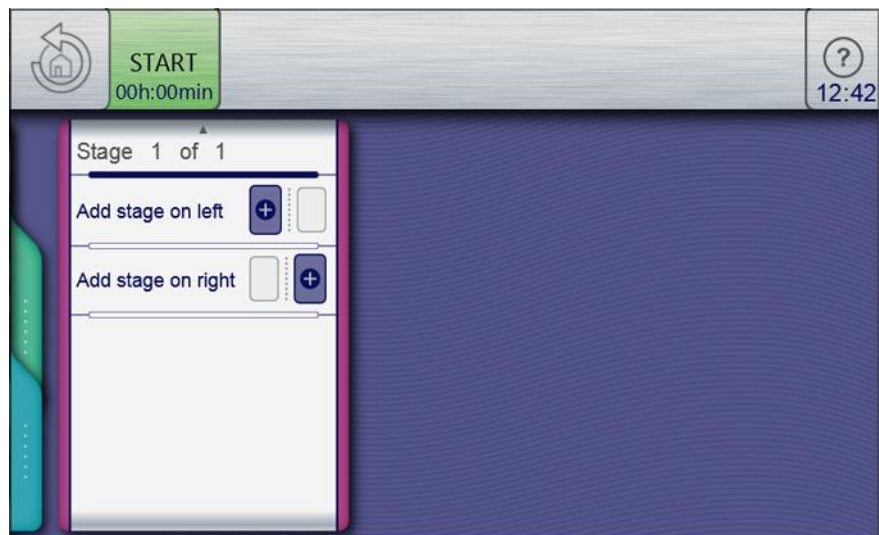

Adding a step in the menu item

Requirement

- Cooking program is created and is open
 - a) A wiping gesture upward opens the next page.
 - ⇒ The next page is displayed.
 - b) Tap the field " Add step at the left".
- or
- a) the field "I had step at the right".
 - ⇒ The "New step" window opens.

- b) Select the cooking mode or function in the window by tapping it.
 - ⇒ The cooking program step display in the window shows the current position of the new step in the cooking program.
- c) Modify the settings for the step.
 - ⇒ The new step is added.

Deleting a cooking program step

NOTICE
If a cooking program has only one step, it cannot be deleted. The function is not active.

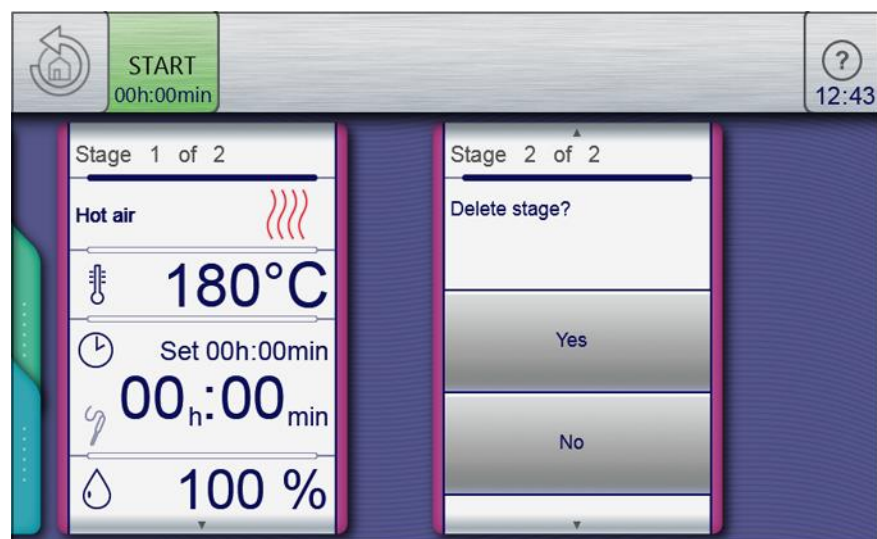

Deleting a step

Requirement

- Cooking program is created and is open
 - a) Select the step.
 - b) A wiping gesture upward opens the next page.
 - ⇒ The next page for the step is displayed.
 - c) Tap the "Delete step" field.
 - ⇒ The *Delete* window is displayed.
 - d) Tap the "Yes" button.
 - ⇒ This deletes the step.
 - ⇒ The positions of the remaining steps in the cooking program are updated.
 - ⇒ The step is deleted.

5.9.2 Saving the cooking program

⚠ CAUTION
Cooking programs that have been created can be saved prior to starting or after completion of the cooking program.

⚠ CAUTION
To save a cooking program, at least one cooking program name and one category must be specified.

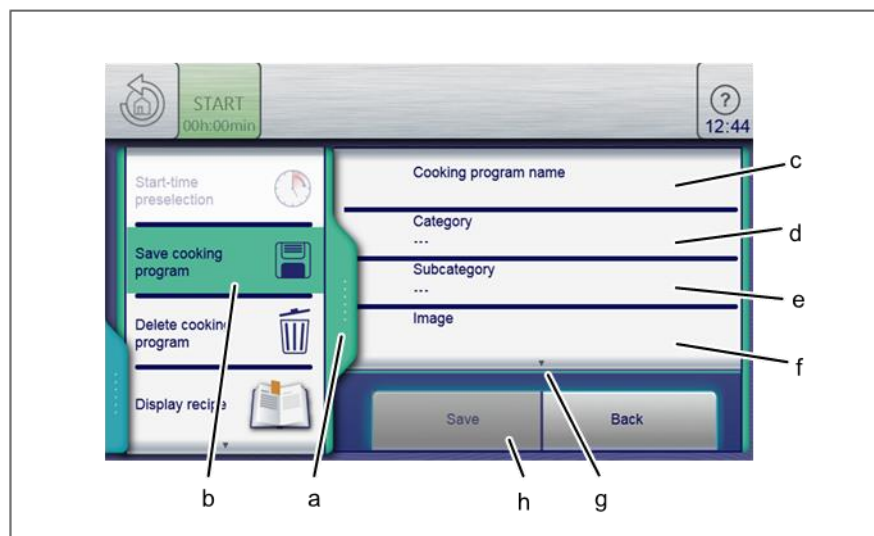

Green tab and cooking program in the Save window

a	Green tab	e	"Subcategory" field
b	"Save cooking program" field	f	"Image" field
c	"Cooking program name" field	g	Next page arrow symbol
d	"Category" field	h	"Save" button

Requirement

➤ Cooking program is created and displayed

- a) Tap the *green* tab.
 - ⇒ The *Tab* window is open.
- b) Tap the "Save cooking program" field.
 - ⇒ The *Save* window is open.

5.9.2.1 Saving the cooking program name

- a) Tap the "Cooking program name" field.

- ⇒ The *Keypad* menu is displayed.
- b) Views the keys to enter the desired program name.
- c) Tap the *Confirm* button.
 - ⇒ The *Keypad* menu closes.
 - ⇒ The program name is displayed in the *Save* window.

5.9.2.2 Entering a category

- a) Tap the "Category" field.
 - ⇒ The *Automatic cooking (autoChef)* menu is displayed.
- b) Tap the field with the desired *Category*.
 - ⇒ The category is set.
 - ⇒ The *Automatic cooking (autoChef)* menu closes.
 - ⇒ The category is displayed in the *Save* window.

5.9.2.3 Entering a subcategory (optional)

- a) Tap the "Subcategory" field.
 - ⇒ The *Subcategory* menu is displayed.
- b) Tap the field with the desired *Subcategory*.
 - ⇒ The subcategory is set.
 - ⇒ The *Subcategory* menu closes.
 - ⇒ The subcategory is displayed in the *Save* window.

5.9.2.4 Assigning an image (optional)

- a) Tap the "Image" field.
 - ⇒ The *Image* menu is displayed.
- b) Select a photo by tapping it.
- c) Select the location to save the photo.
- d) Tap the "Photos in unit" button or the "Photos on USB flash drive" button.
 - ⇒ The photo is selected.
 - ⇒ The *Image* menu closes.
 - ⇒ The name of the photo is displayed in the *Save* window.

5.9.2.5 Assigning a recipe (optional)

- a) Tap the "Recipe" field.
 - ⇒ The *Recipe* menu is displayed.
- b) Tap the "Empty recipe" field.

- c) Select the save location.
- d) Tap the "Recipes in unit" button or the "Recipes on USB flash drive" button.
 - ⇒ The recipe is set.
 - ⇒ The *Recipe* menu closes.
 - ⇒ The name of the recipe is displayed in the *Save* window.
- e) Tap the "Save" button in the *Save* window.
 - ⇒ The cooking program is saved.
 - ⇒ The *Confirm* window is displayed.
- f) Tap the Confirm button.
 - ⇒ The *green* tab closes.
 - ⇒ The cooking program is saved.

5.9.2.6 Selecting favourites (optional)

- a) Tap the "Show favourites" field.
 - ⇒ The *Show favourites* menu is displayed.
- b) Tap the "Yes" button or the "No" button.
 - ⇒ Tapping Yes displays the cooking program in the Favourites menu.

5.9.2.7 Selecting characteristics of the food to be cooked (optional)

- a) Tap the "Frozen food" field.
 - ⇒ The *Frozen food* menu is displayed.
- b) Tap the "Yes" button or the "No" button.
 - ⇒ Tapping Yes selects the food to be cooked as a frozen food.

5.9.2.8 Assigning an identification (optional)

- a) Tap the "Identification" field.
 - ⇒ The *Identification* menu is displayed.
- b) Tap the *Barcode scanner* button.
 - ⇒ Scan the barcode and assign to a cooking program or to food to be cooked.

5.9.2.9 Selecting QualityControl

- a) Tap the "QualityControl" field.
 - ⇒ The *QualityControl* menu is displayed.
- b) Tap the "No" button.

- ⇒ QualityControl is switched off for the cooking program.
- c) Tap the "Yes" button.
 - ⇒ Tapping Yes sets the cooking program for a minimal amount of food to be cooked.
 - ⇒ QualityControl automatically adjusts the cooking time for a larger charge.

5.9.3 Exporting a cooking program

NOTICE
Previously exported cooking programs on the USB flash drive will be overwritten.

Requirement

- Cooking program open
- Cooking program saved
- USB flash drive inserted
- a) Tap the *green* tab.
 - ⇒ The *Tab* window is open.
- b) Tap the "Export cooking programs" field.
 - ⇒ The *Operating instructions* window opens.
- c) Read and then close the displayed operating instructions.
- d) Close the *Operating instructions* window.
- e) Tap the *Confirm* button.
 - ⇒ The cooking program is exported to the USB flash drive.
 - ⇒ The *Confirm* window is displayed.
- f) Tap the *Confirm* button.
 - ⇒ The *green tab* window closes.
 - ⇒ The cooking program is exported.

5.10 Automatic cooking (autoChef)

In the "Automatic cooking" mode, all cooking programs stored in the unit are available. The cooking program is selected in the *Automatic cooking* menu.

5.10.1 Opening the Automatic cooking menu

Requirement

- The unit is on
- The main menu is displayed
- a) Tap the "Automatic cooking" button.
 - ⇒ The *Automatic cooking (autoChef)* menu is displayed.

5.10.2 Finding and opening a cooking program

Finding and opening a cooking program by category

Cooking programs can be found in the *Automatic cooking* menu by category and subcategory.

NOTICE

Arrow symbols in a window always display the next or previous page. A wiping gesture upward or downward opens the corresponding window.

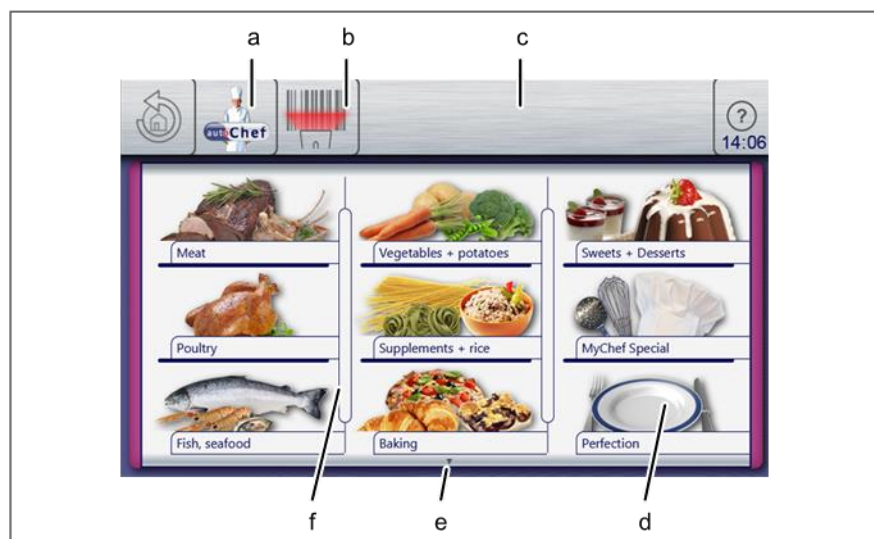

Automatic cooking menu

a	"autoChef" button	d	Category field
b	BarcodeScan button	e	Next page arrow symbol
c	Information bar	f	Separating bar

Requirement

- The unit is on
- Main menu is displayed
- a) Tap the "Automatic cooking" button.
 - ⇒ The *Automatic cooking* menu is displayed.
 - ⇒ An additional menu page is displayed.
- b) Tap the field with the desired category.
 - ⇒ The Subcategory menu is displayed.
- c) Tap the field with the desired subcategory.
 - ⇒ The Recipe menu with all recipes in the subcategory is displayed.
- d) Tap the field with the desired recipe.
 - ⇒ The cooking program is selected and being loaded.

5

Operating the unit

Automatic cooking (autoChef)

- ⇒ The cooking program steps are displayed.
- ⇒ The cooking program is open.

Finding and opening a cooking program in the cookbook

All cooking programs are saved in the cookbook in alphabetical order.



Find cooking program window

Requirement

- The unit is on
- Main menu is displayed
- a) Tap the "Automatic cooking" button.
 - ⇒ The Category menu is displayed.
- b) Tap the "autoChef" button in the information bar.
 - ⇒ The *autoChef* window is displayed.
- c) Tap the *Find cooking program* field.
 - ⇒ The *Entry* window is displayed.
- d) Using the keypad, enter the letters for the name to be found.
 - ⇒ A filtered list is displayed in the *Result* window.
- e) Tap the field with the name found.
 - ⇒ The cooking program is selected and being loaded.
 - ⇒ The cooking program steps are displayed.
- ⇒ The cooking program is open.

5.10.3 Starting the cooking program

NOTICE
The current step in the cooking program is highlighted. Upon completion, the following step automatically appears in the display.

Requirement

- Cooking program open

- a) Tap the "START" button in the information bar.
 - ⇒ The cooking program starts.
 - ⇒ The "START" button in the information bar changes to the "STOPP" button.
 - ⇒ The remaining cooking program time is displayed in the "STOPP" button.
- ⇒ The cooking program is started.

5.10.4 Ending the cooking program

Requirement

- Cooking program started
 - Cooking program time has not elapsed
 - a) Tap the "STOPP" button in the information bar.
- or
- a) Wait for the cooking time to end.
 - ⇒ Cooking program has ended.
 - ⇒ The "STOPP" button in the information bar changes to the "START" button.
 - ⇒ The cooking program has ended.

5.10.5 Modifying the cooking program

	NOTICE
	Tabs available only within cooking programs. Tapping the tabs provides faster access to their functions.
	NOTICE
	The current step in the cooking program is highlighted and can be modified. All settings of a step can be modified.
	NOTICE
	After the settings are made, the modified cooking program can be saved. The cooking program is overwritten if a new cooking program name is not specified.

Modifying a cooking program after the program has started

Requirement

- Cooking program started
- Cooking program has not elapsed

- a) Modify the settings for the current step.
 - ⇒ The modifications of the step become active immediately.
 - ⇒ The modifications of the step are displayed.
- b) Tap the "Continue" field.
 - ⇒ The active step is being ended.
 - ⇒ The next step is being started.
 - ⇒ Steps advance in the *Settings* window.
- ⇒ The cooking program is modified.

Modifying a cooking program before the program has started

Requirement

- Cooking program open
- Cooking program not started
- a) Modify various steps.
- b) Use a wiping gesture to reach the individual step to be modified.
- c) Modify the settings for the step.
 - ⇒ The modifications of the step are displayed.
 - ⇒ The cooking program can be started without being saved.
 - ⇒ If the modifications are to be saved, continue with the next step.
- d) Tap the *green* tab.
 - ⇒ The *Tab* window is open.
- e) Save the cooking program.
 - ⇒ All modifications to the cooking program are saved.
- ⇒ The saved cooking program is modified.

5.10.6 Deleting a cooking program

Requirement

- Cooking program open
- Cooking program not started
- a) Tap the *green* tab.
- b) The *Tab* window is open.
- c) Tap the "Delete cooking program" field.
 - ⇒ The *Delete* window is displayed.
- d) Tap the "Yes" button.
 - ⇒ The cooking program is being deleted.
 - ⇒ The *Confirm* window is displayed.
- e) Tap the *Confirm* button.
 - ⇒ The *green* tab closes.
- ⇒ The cooking program is deleted.

5.10.7 Exporting and importing a cooking program

Exporting a cooking program

When exporting, all user-created cooking programs in the cookbook are exported.

NOTICE
Previously exported cooking programs on the USB flash drive will be overwritten.

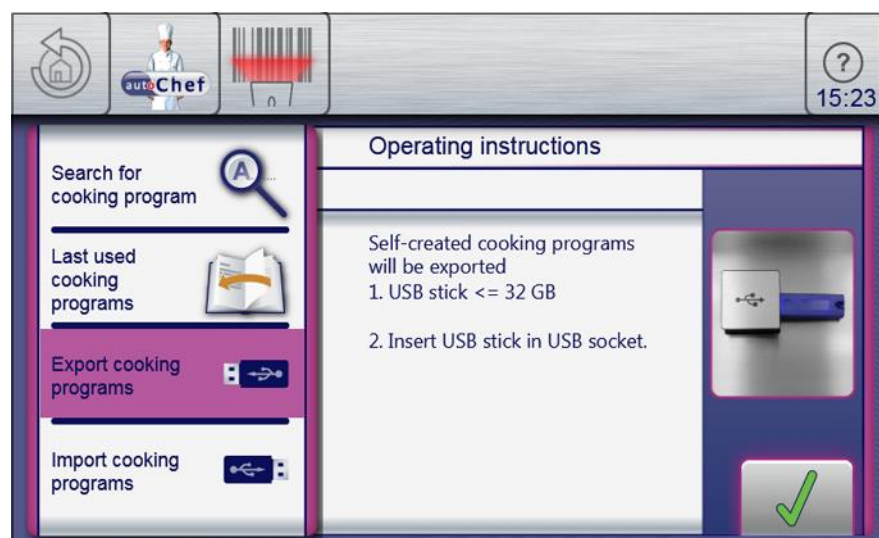

Export cooking program window

Requirement

- > USB flash drive inserted
 - > *Automatic cooking* open
 - > User-created cooking programs are saved in the cookbook
- a) Tap the "autoChef" button in the information bar.
 - ⇒ The *autoChef* window opens.
 - b) Tap the "Export cooking programs" field.
 - ⇒ The *Operating instructions* window opens.
 - ⇒ Read the displayed operating instructions.
 - c) Tap the *Confirm* button.
 - ⇒ All user-created cooking programs are exported to the USB flash drive from the cookbook.
 - ⇒ The *Confirm* window is displayed.
 - d) Tap the *Confirm* button.
 - ⇒ The *Confirm* window closes.
 - ⇒ The cooking programs are exported.

Importing cooking programs

When importing, new cooking programs are added to the cookbook.

NOTICE

Existing cooking programs can be overwritten or the file names of the imported cooking programs can have a supplement added.

Requirement

- USB flash drive inserted
- Automatic cooking menu open.
- a) Tap the "autoChef" button in the information bar.
 - ⇒ The *autoChef* window opens.
- b) Tap the "Import cooking programs" field.
 - ⇒ The *Operating instructions* window opens.
 - ⇒ Read the displayed operating instructions.
- c) Tap the *Confirm* button.
 - ⇒ All cooking programs on the USB flash drive are imported to the cookbook.
 - ⇒ The *Operating instructions* window is displayed.
- d) Tap the "OK" button.
 - ⇒ The cooking programs are imported.

5.11 Pausing and finishing use

- a) Switch off the unit during pauses and when finished using it.

Period of idleness last more than 2 days

Requirement

- GN containers, baking sheets and grates removed from the cooking zone
- No food to be cooked in the cooking zone
- a) Operate the hand shower for 1 minute.
- b) Run the unit in the Steaming mode for 7 minutes at 100°C (212°F).

Period of idleness lasting more than 7 days

Requirement

- GN containers, baking sheets and grates removed from the cooking zone
- No food to be cooked in the cooking zone
- a) Operate the hand shower for 5 minutes.
- b) Run the unit in the Steaming mode for 1 hour at 100°C (212°F).

6 Cleaning and caring for the unit

	 WARNING
	Risk of burns from hot surfaces a) Allow surfaces to cool prior to cleaning.
	SAFETY INSTRUCTIONS
	Risk of physical damage from extremely abrupt cooling a) Do not cool shock the unit by cooling it abruptly.
	SAFETY INSTRUCTIONS
	Risk of physical damage from improper cleaning a) Do not clean the unit with a high-pressure cleaner.

6.1 Preventing corrosion

- Keep the surfaces of the unit clean, with access to air.
- Remove lime, grease, starch and protein deposits.
- Remove salt accumulations.
- Expose parts made from non-rusting steel only briefly to contact with highly acidic foods, spices, salts or the like.
- Avoid damaging the stainless steel surface with other metal items, for instance, steel spatulas or steel wire brushes.
- Prevent contact with iron and steel, for instance, steel wool and steel spatulas.
- Do not use bleaching or chlorine-containing cleaning agents.
- Clean contact surfaces with water.

6.2 Remove rust spots

- Remove fresh rust spots with a mild abrasive or fine sandpaper.
- Always remove rust spots completely.
- Expose treated areas to fresh air for at least 24 hours. During this time, do not allow any contact with greases, oils or foods so that a new protective layer can form.

6.3 Cleaning the housing

Requirement

Unit switched off and cool

	SAFETY INSTRUCTIONS
	<p>Risk of physical damage from improper cleaning</p> <p>a) Do not clean the housing with highly abrasive or chemically aggressive cleaning agents.</p> <p>b) Do not clean the housing with highly abrasive sponges.</p>

a) Clean the housing with warm water and a commercially available detergent.

6.4 Cleaning the handle, operating elements and operating panel membrane

	SAFETY INSTRUCTIONS
	<p>Risk of physical damage from improper cleaning</p> <p>a) Do not clean the surface with highly abrasive or chemically aggressive cleaning agents.</p> <p>b) Do not clean the surface with highly abrasive sponges.</p>

Requirement

➤ Unit switched off

a) Clean the door handle, operating elements and control panel with a damp cloth and commercially available detergent.

6.5 Cleaning the touchscreen

	SAFETY INSTRUCTIONS
	<p>Risk of physical damage from improper cleaning</p> <p>a) Do not clean the touchscreen with highly abrasive or chemically aggressive cleaning agents.</p> <p>b) Do not clean the touchscreen with highly abrasive sponges.</p>
	NOTICE
	<p>A cleaning time of 20 seconds is provided. During this time, the touchscreen cannot be operated.</p>

Requirement

- Equipment function menu displayed
- a) Tap the "Clean touchscreen" field.
 - ⇒ The touchscreen no longer reacts when touched.
 - ⇒ The *Clean* window opens.
 - ⇒ The cleaning time is updated.
- b) Clean the touchscreen within 20 seconds.
 - ⇒ The Clean window closes.
 - ⇒ The equipment function menu is displayed.
- ⇒ The touchscreen is clean.

6.6 Cleaning the door seal

	<p>SAFETY INSTRUCTIONS</p> <p>Risk of physical damage from improper cleaning Animal fats in combination with high temperatures can damage the door seal very quickly if it is not maintained properly.</p> <ul style="list-style-type: none">a) Clean the door seal regularly.b) Do not use aggressive cleaners.
	<p>NOTICE</p> <p>During automatic cleaning and semi-automatic cleaning, the outside surface of the door seal is not cleaned.</p> <p>The door seal must be cleaned separately after each semi-automatic and automatic cleaning.</p>

- a) When finished using the unit, clean the door seal with warm water and a commercially available detergent.

	NOTICE
	If the unit is used primarily for roasting, also clean the door seal during pauses in use.

6.7 Cleaning the cooking zone door

	⚠ WARNING
	Risk of burns from hot surfaces a) Allow surfaces to cool prior to cleaning.
	SAFETY INSTRUCTIONS
	Risk of physical damage from improper cleaning of the surface a) Do not use abrasive cleaners or cloths. b) Do not use grill cleaners.

6.7.1 Cleaning the door with hygienic glazing

- a) Remove residual calcium deposits from the glass window with vinegar or citric acid.

6.8 Cleaning the steam outlet

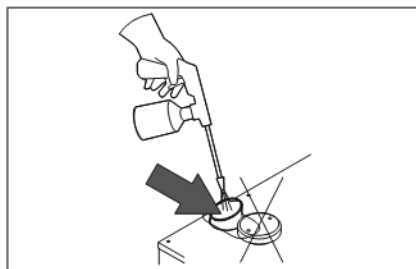

Cleaning the steam outlet

	SAFETY INSTRUCTIONS
	Risk of physical damage from deposits a) Check the steam outlet and connected piping for deposits.

	NOTICE
	Use a liquid cleaner containing at most 20% sodium or potassium hydroxide. Flushing with water is not necessary.

- a) Examine the steam outlet and connected piping for deposits.
- b) Spray liquid cleaner into the steam outlet.

6.9 Cleaning the condensation hood (optional)

	⚠ CAUTION
	Risk of fire from dirt and grease accumulation a) Clean the hood after use. b) Follow the cleaning instructions.

	⚠ WARNING
	Risk of burns from hot surfaces a) Allow surfaces to cool prior to cleaning.

	⚠ CAUTION
	Risk of injury from sharp edges a) Wear protective gloves.

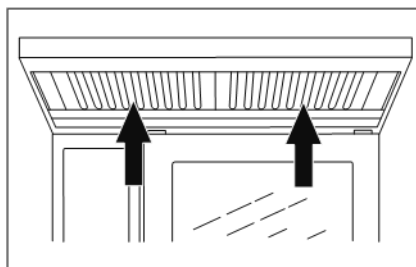

Cleaning the condensation hood

Requirement

- > Unit and hood disconnected from the electric mains
 - > Unit and hood cool
- a) Clean the housing daily with warm water and a commercially available cleaner.

- b) Push the grease filter upwards.
- c) Pull the grease filter on the underside of the hood forward to remove it.
- d) Clean the grease filter and hood with a commercially available cleaning agent.
- e) Rinse and dry the grease filter, and replace it in the hood.

6.10 Removing calcium deposits from the unit

NOTICE
To remove calcium deposits manually, fill a manual spray gun with a special decalcifier.

Requirement

- Cooking zone temperature less than 40°C (140°F)
- Cooking zone cleaned
- a) Dilute special decalcifier with water in a ratio of 1:2.
- b) Open the air diverter.
- c) Spray the diluted special decalcifier into the cooking zone.
- d) Allow to act for 30 minutes.
- e) Rinse the cooking zone thoroughly.
- f) Examine the cooking zone for any remaining calcium deposits.
- g) If necessary, repeat the decalcification.
- h) Open the cooking zone door and leave it ajar until the unit is used again.
 - ⇒ This extends the service life of the door seal.
 - ⇒ No moisture builds up in the cooking zone.

6.11 Cleaning the cooking zone automatically with WaveClean

6.11.1 Preparing for cleaning

SAFETY INSTRUCTIONS
<p>Risk of physical damage from improper cleaning</p> <ul style="list-style-type: none"> a) Do not clean the unit with a high-pressure cleaner.

Requirement

- GN containers, baking sheets and grates removed from the cooking zone
- a) Remove any food remains from the cooking zone.
 - ⇒ The drain screen is not obstructed.

Cleaning the cooking zone automatically with WaveClean

- b) Leave only the support rack in the cooking zone in countertop units and the tray trolley in the cooking zone in floor-standing units.
- c) Close the cooking zone door.

6.11.2 Selecting the cleaning level

NOTICE
Despite different cleaning times, all cleaning levels required the same amount of water.

Requirement

- The unit is on
- Main menu is displayed
- a) Tap equipment function.
- b) Tap the *WaveClean* symbol.
- c) Select the cleaning level.
- d) Tap the "START STOPP" button.
 - ⇒ If necessary, the cooling zone cools until the cleaning temperature of 60°C (140°F) is reached.

6.11.3 Inserting the cleaning cartridge

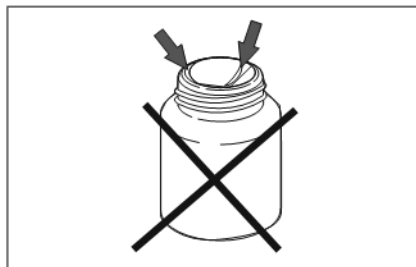

Wax seal on the cartridge damaged

SAFETY INSTRUCTIONS
<p>Use only cleaning cartridges with an undamaged wax seal.</p> <p>If the wax seal is damaged, the cleaner can enter the cleaning circuit prematurely or not dissolve completely, so that complete cleaning is no longer assured.</p> <p>Insert the cleaning cartridges only when requested to do so.</p>

Requirement

- Cleaning cartridges sealed and undamaged
- a) Open the cooking zone door.
- b) Open the cover on the cartridge.

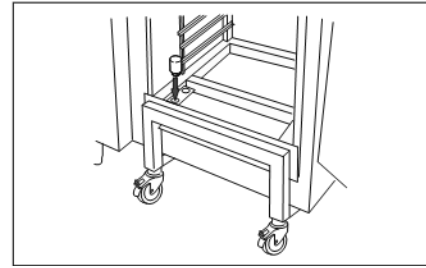
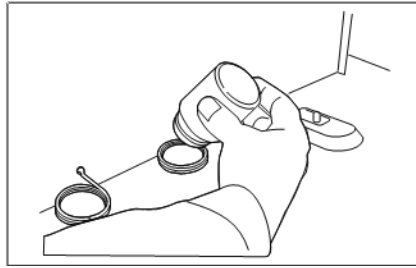

Inserting the cartridge into the countertop unit or the floor-standing unit

- c) Place the cartridge into the holder on the air diverter or into the holder on the tray trolley.

SAFETY INSTRUCTIONS

Never operate the unit in the automatic cleaning mode without a cleaning cartridge

In the event of severe soiling, select the "extra" cleaning level and use 2 cleaning cartridges.

- a) Close the cooking zone door.

6.11.4 Starting automatic cleaning

Requirement

- Water connection is opened
 - The unit is on
 - Cooking zone temperature at 60 °C (140°F)
- a) Tap the "START STOPP" button.
- ⇒ The display shows the remaining time.

6.11.5 Cancelling automatic cleaning

- a) Tap the "STOPP" button.
- ⇒ Automatic cleaning is cancelled.
 - ⇒ Automatic rinsing starts and cannot be cancelled.
 - ⇒ Upon completion, a request appears to remove the cartridge.
- a) Remove the cartridge.

6.11.6 Ending automatic cleaning

Requirement

- Automatic rinsing has stopped after the cleaning program was cancelled or the cleaning time has elapsed
- a) Open the cooking zone door.
- b) Remove the empty cleaning cartridge.
- c) Use the hand shower to thoroughly rinse away any remaining cleaner or rinse aid.

d) Leave the cooking zone door open slightly until the unit will be used again.

⇒ This extends the service life of the door seal.

⇒ No moisture builds up in the cooking zone.

6.12 Cleaning the cooking zone manually

6.12.1 Preparing the cooking zone

	SAFETY INSTRUCTIONS
	Risk of physical damage from improper cleaning a) Do not clean the unit with a high-pressure cleaner.

Requirement

➤ GN containers, baking sheets and grates removed from the cooking zone

a) Remove any food remains from the cooking zone.

⇒ The drain screen is not obstructed.

b) Leave only the support rack in the cooking zone in countertop units and the tray trolley in the cooking zone in floor-standing units.

c) Close the cooking zone door.

6.12.2 Starting the cleaning program

Requirement

➤ The unit is on

a) Tap manual cleaning.

6.12.3 Spraying the cleaner

	⚠ CAUTION
	Dangerous situation Failure to observe precautions can result in slight to moderately severe injuries. a) Wear protective clothing. b) Wear breathing protection.
	SAFETY INSTRUCTIONS
	Risk of physical damage from exceeding the recommended acting time of the cleaner a) Do not allow the cleaner to act longer than specified by the program.

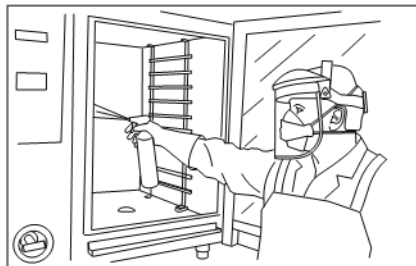

Spraying the cooking zone

- a) When the message "Spray cleaner" appears, open the cooking zone door.
- b) Spray the cooking zone, heat register and fan wheel with cleaner.

6.12.4 Allowing the cleaner to act

- a) Close the cooking zone door.
 - ⇒ The acting time starts.
 - ⇒ The display shows the remaining acting time.

6.12.5 Starting cleaning

- a) The acting time has elapsed, the cleaning process starts.
 - ⇒ The cooking zone is heated.
 - ⇒ The display shows the remaining time.

6.12.6 Rinsing the cooking zone

Requirement

- The cleaning process has completed
 - a) Open the cooking zone door.
 - b) Using the hand shower, thoroughly rinse through the openings in the air diverter.
 - c) Thoroughly rinse the cooking zone with the hand shower for 3 minutes.
 - d) Close the cooking zone door.

6.12.7 Drying the cooking zone

Requirement

- Cooking his own door closed
 - a) The drying process starts automatically.

	<i>NOTICE</i>
	The cooking zone is heated for 5 minutes.

- a) After the end of the drying process, a signal sounds.
 - ⇒ "End" appears on the display.
- b) Open the cooking zone door and leave it ajar until the unit is used again.
 - ⇒ This extends the service life of the door seal.
 - ⇒ No moisture builds up in the cooking zone.

6.13 Swinging the air diverter open and closed

 CAUTION	
<p>Pinch hazard from rotating fan</p> <p>a) Prior to working on the unit, ensure that the unit has been disconnected from the mains.</p> <p>b) Do not operate the unit without the air diverter.</p>	

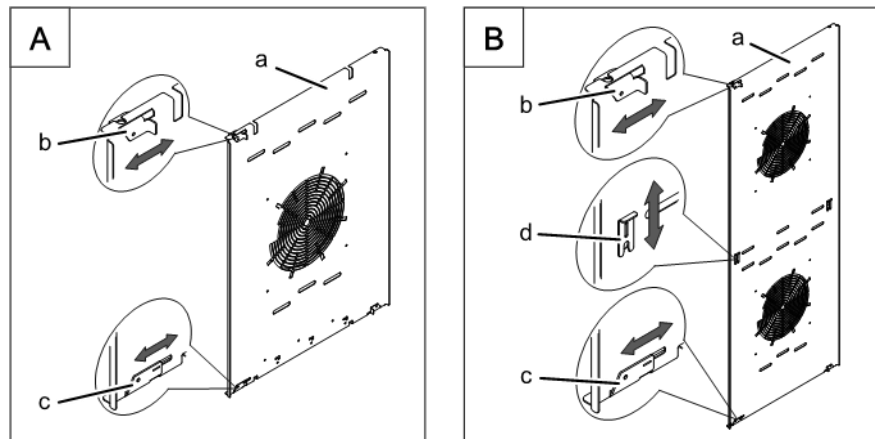

Air diverter fasteners on countertop and floor-standing units

a	Air diverter	c	Lower fastener
b	Upper fastener	d	Centre fastener

Swinging the air diverter open

Requirement

- Unit switched off
- a) Remove the left support rack; present only in size 6 and size 10.
- b) Loosen the upper fastener.
- c) Loosen the lower fastener.
- d) Loosen the centre fastener; present only in size 20.
- e) Swing the air diverter toward the back wall.

Swinging the air diverter closed

- a) Swing back the air diverter along the side wall.
- b) Close the upper fastener.
- c) Close the lower fastener.
- d) Close the centre fastener; present only in size 20.
- e) Check the fasteners.
- f) Insert the left support rack; present only in size 6 and size 10.

6.14 Inspecting the unit

6.14.1 Performing a visual inspection

SAFETY INSTRUCTIONS
<p>Risk of physical damage from improper inspection</p> <p>a) Inspect in accordance with the inspection intervals.</p> <p>b) Have inspections performed by a capable user.</p> <p>c) In the event of damage or signs of wear, contact customer service immediately and stop using the unit.</p>

Requirement

- Unit empty and cleaned
- Cooking zone door opened completely
- a) Inspect housing, cooking zone door and cooking zone yearly for deformation and cracks.
- ⇒ Visual inspection has been performed.

6.14.2 Running CombiDoctor (self-diagnostic program)

NOTICE
Incorrect results are displayed when the unit is warm. Allow the unit to cool.

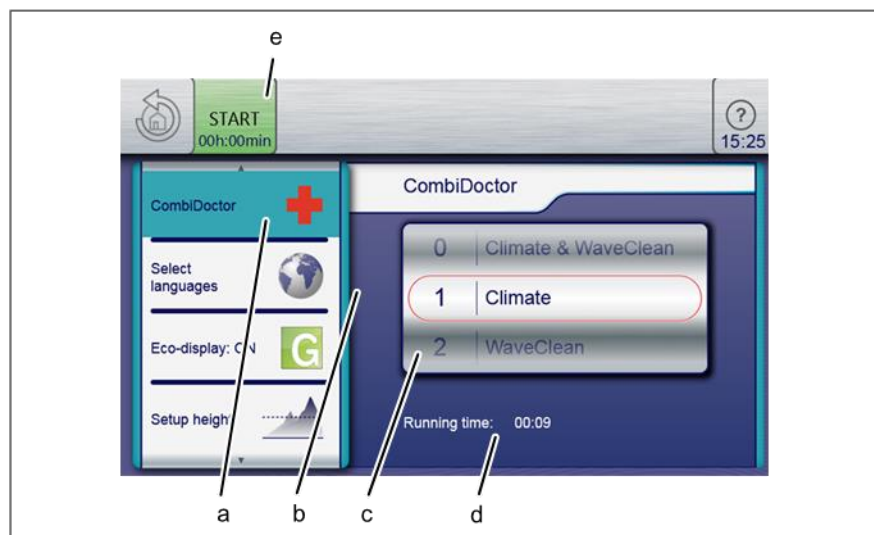

Select the self-diagnostic program setting

a	CombiDoctor field	d	Remaining time
b	Setting window	e	START button
c	Roller		

Requirement

- Water connection is opened
- Energy optimization system deactivated (optional)
- Cooking zone empty, no grates and no containers, with support rack or tray trolley
- The unit is on
- No errors displayed
- Equipment functions displayed
- a) Open the *Settings* menu.
- b) Enter the password.
- c) Tap the "CombiDoctor" field.
- d) Using a wiping gesture, set the roller to the desired self-diagnostic program.
 - ⇒ The set self-diagnostic program displays the elapsed time.
- e) Press the "START" button.
 - ⇒ A help text is displayed.
- f) Open the cooking zone door briefly and then close it.
 - ⇒ The self-diagnostic program continues automatically.
- ⇒ On completion of self-diagnosis, the result is displayed. Note the error message and forwarded to your local customer service.

7 Troubleshooting

7.1 Causes of errors and remedies

If an error occurs during operation, the error group and the error number within the group are displayed.

7.2 Nameplate

When contacting customer service, please always provide the data from the nameplate:

Serial number (SN)	
Type number (TYP)	

8 Dispose of unit in an environmentally responsible manner

The unit has been designed to provide a lifetime of 10 years with average use.

Did not dispose of the unit in normal trash. These materials damage your health and the environment when disposed of in normal trash or treated improperly. Dispose of the unit in accordance with local regulations for used appliances. If you have questions, please contact the responsible agencies (for instance, waste disposal).

Unit

In addition to valuable materials, used electrical and electronic equipment also contains harmful substances that were needed for their operation and safety.

Cleaning agents

Dispose of leftover cleaning agents and cleaning agent containers in accordance with the information provided by the cleaning agent's manufacturer. Observe applicable regional regulations.



Henny Penny Corporation
P.O.Box 60
Eaton, OH 45320

1-937-456-8400
1-937-456-8402 Fax

Toll free in USA
1-800-417-8417
1-800-417-8434 Fax

www.hennypenny.com

* FM05-11" - @* Henny Penny Corp., Eaton, Ohio 45320, Revised 8-15-14