

HENNY PENNY™

Global Foodservice Solutions

**Henny Penny
Pressure Fryer
Model 581**

SERVICE MANUAL

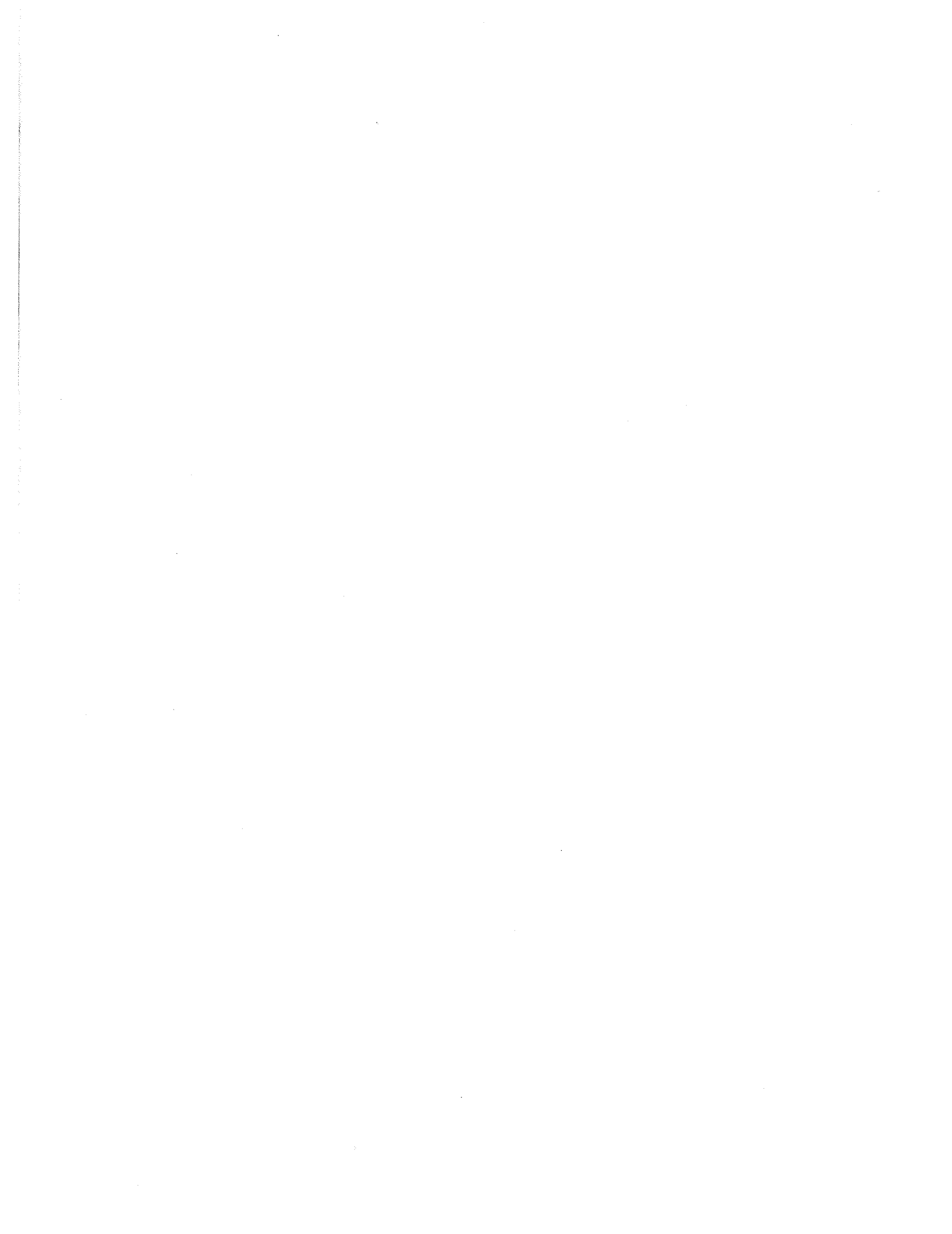

Henny Penny Pressure Fryer Model 581

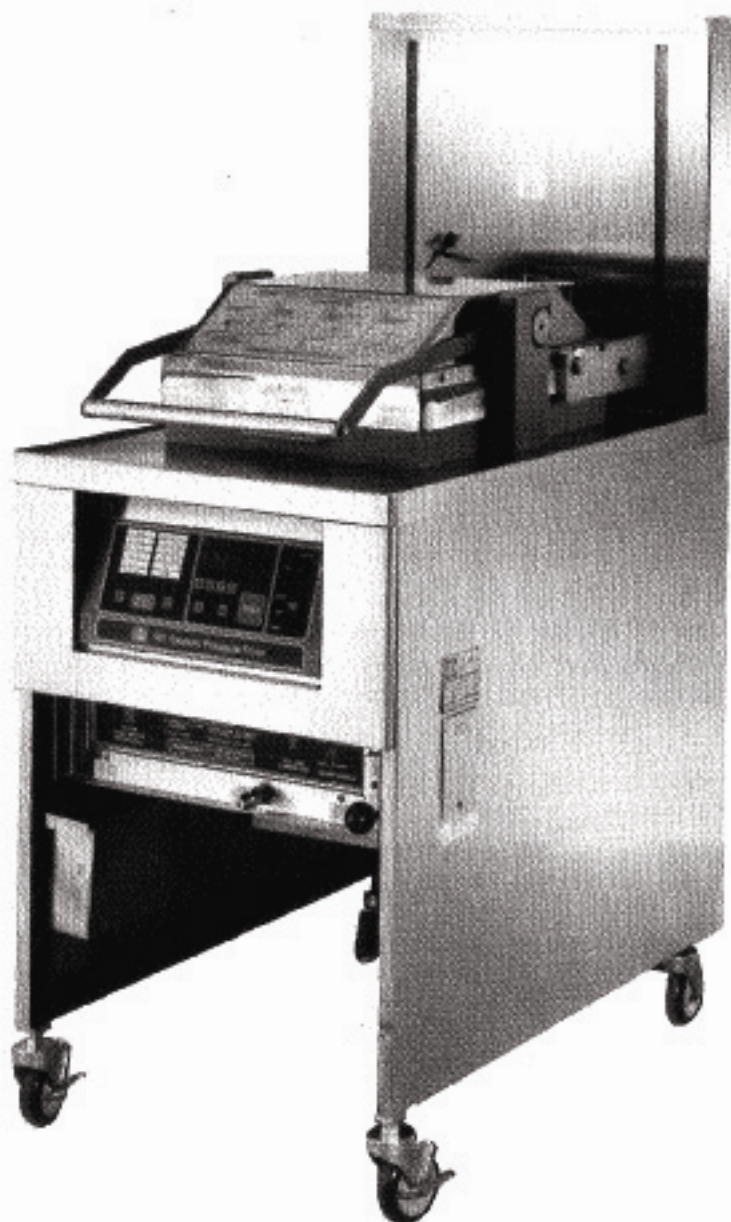

Product Number 02324

LIMITED WARRANTY FOR HENNY PENNY APPLIANCES

Subject to the following conditions, Henny Penny Corporation makes the following limited warranties to the original purchaser only for Henny Penny appliances and replacement parts:

NEW EQUIPMENT: Any part of a new appliance, except lamps and fuses, which proves to be defective in material or workmanship within two (2) years from date of original installation, will be repaired or replaced without charge F.O.B. factory, Eaton, Ohio, or F.O.B. authorized distributor. To validate this warranty, the registration card for the appliance must be mailed to Henny Penny within ten (10) days after installation.

REPLACEMENT PARTS: Any appliance replacement part, except lamps and fuses, which proves to be defective in material or workmanship within ninety (90) days from date of original installation will be repaired or replaced without charge F.O.B. factory, Eaton, Ohio, or F.O.B. authorized distributor.

The warranty for new equipment and replacement parts covers only the repair or replacement of the defective part and does not include any labor charges for the removal and installation of any parts, travel or other expenses incidental to the repair or replacement of a part.

EXTENDED FRYPOT WARRANTY: Henny Penny will replace any frypot that fails due to manufacturing or workmanship issues for a period of up to seven (7) years from date of manufacture. This warranty shall not cover any frypot that fails due to any misuse or abuse, such as heating of the frypot without shortening.

0 TO 3 YEARS: During this time, any frypot that fails due to manufacturing or workmanship issues will be replaced at no charge for parts, labor, or freight. Henny Penny will either install a new frypot at no cost or provide a new or reconditioned replacement fryer at no cost.

3 TO 7 YEARS: During this time, any frypot that fails due to manufacturing or workmanship issues will be replaced at no charge for the frypot only. Any freight charges and labor costs to install the new frypot as well as the cost of any other parts replaced, such as insulation, thermal sensors, high limits, fittings, and hardware, will be the responsibility of the owner.

Any claim must be represented to either Henny Penny or the distributor from whom the appliance was purchased. No allowance will be granted for repairs made by anyone else without Henny Penny's written consent. If damage occurs during shipping, notify the sender at once so that a claim may be filed.

THE ABOVE LIMITED WARRANTY SETS FORTH THE SOLE REMEDY AGAINST HENNY PENNY FOR ANY BREACH OF WARRANTY OR OTHER TERM. BUYER AGREES THAT NO OTHER REMEDY (INCLUDING CLAIMS FOR ANY INCIDENTAL OR CONSEQUENTIAL DAMAGES) SHALL BE AVAILABLE.

The above limited warranty does not apply (a) to damage resulting from accident, alteration, misuse, or abuse; (b) if the equipment's serial number is removed or defaced; or (c) for lamps and fuses. THE ABOVE LIMITED WARRANTY IS EXPRESSLY IN LIEU OF ALL OTHER WARRANTIES, EXPRESS OR IMPLIED, INCLUDING MERCHANTABILITY AND FITNESS, AND ALL OTHER WARRANTIES ARE EXCLUDED. HENNY PENNY NEITHER ASSUMES NOR AUTHORIZES ANY PERSON TO ASSUME FOR IT ANY OTHER OBLIGATION OR LIABILITY.

TABLE OF CONTENTS

Section	Page
Section 1. INTRODUCTION	1-1
1-1. Pressure Fryer	1-1
1-2. Proper Care	1-1
1-3. Assistance	1-1
1-4. Safety	1-2
Section 2. INSTALLATION	2-1
2-1. Unpacking Instructions	2-1
2-2. Selecting the Fryer Location	2-4
2-3. Leveling the Fryer	2-4
2-4. Ventilation of Fryer	2-4
2-5. Electrical Requirements	2-4
2-6. Testing the Fryer	2-5
2-7. Operational Checks	2-5
2-8. International Electrical Requirements	2-6
Section 3. OPERATION	3-1
3-1. Operating Controls	3-1
3-2. Lid Operation	3-6
3-3. Filling or Adding Shortening	3-8
3-4. Care of the Shortening	3-8
3-5. Start-Up (Preheat) Procedures	3-9
3-6. Frying Procedures	3-10
3-7. Filtering	3-12
3-8. Changing the Filter Envelope	3-14
3-9. Filter Pump Problem Prevention	3-16
3-10. Cleaning the Frypot	3-17
3-11. Seasonal Shutdown	3-19
3-12. Cleaning the Operating Valve	3-19
3-13. Night Closing Procedures	3-20
Section 4. TROUBLESHOOTING	4-1
4-1. Introduction	4-1
4-2. Troubleshooting	4-1
Section 5. MAINTENANCE	5-1
5-1. Introduction	5-1
5-2. Arrangement	5-1
5-3. Maintenance Hints	5-1
5-4. Removing Complete Panel Assy.	5-1
5-5. High Temperature Limit Control	5-2
5-6. Fuse Holders	5-4
5-7. Cook/Pump Switch	5-4
5-8. Contactors	5-6
5-9. Heating Elements	5-8

TABLE OF CONTENTS

Section	Page
5-10. Drain Switch	5-10
5-11. Temperature Probe Replacement.....	5-11
5-12. Control Panel Replacement.....	5-12
5-13. Switchboard Replacement	5-13
5-14. Heat Relay.....	5-14
5-15. Pressure Relay.....	5-15
5-16. “E10” Relay	5-16
5-17. Keyswitch	5-17
5-18. Transformer.....	5-18
5-19. Reversing the Lid Gasket.....	5-19
5-20. Lid Counterweight	5-20
5-21. Pressure Pads	5-21
5-22. Lid Adjustment	5-22
5-24. Adjusting the Magnet Plate (SN: GG015JJ and below)	5-23
5-25. Solenoid Valve.....	5-23
5-26. Operating Control Valve.....	5-25
5-27. Removal & Cleaning of Safety Relief Valve.....	5-27
5-28. Pressure Gauge.....	5-27
5-29. Drain Valve Removal	5-28
5-30. Nylatron Slides.....	5-28
Section 6. PROGRAMMING	6-1
6-1. Introduction.....	6-1
6-2. Programming.....	6-1
6-3. Load Compensation	6-4
6-4. Load Anticipation	6-4
6-5. Proportional Control	6-4
6-6. Filter Cycle Count.....	6-5
6-7. Idle Mode.....	6-5
6-8. Melt Mode.....	6-6
6-9. Programming 1 st Cycle	6-7
6-10. One Button Henny Penny Parameters.....	6-7
6-11. Timing Through Power Interruptions.....	6-7
6-12. Clean-Out Mode.....	6-8
Section 7. PROGRAMMING	7-1
7-1. Introduction.....	7-1
7-2. Genuine Parts	7-1
7-3. When Ordering Parts.....	7-1
7-4. Prices.....	7-1
7-5. Delivery.....	7-1
7-6. Warranty	7-1
7-7. Recommended Spare Parts for Distributors.....	7-1
Exploded Views	7-2 to 7-19
Wiring Diagrams	
Distributor Lists – Domestic and International	

SECTION 1. INTRODUCTION

1-1. PRESSURE FRYER

The Henny Penny Pressure Fryer is a basic unit of food processing equipment which is used only in institutional and commercial food service operations.

P-H-T

A combination of Pressure, Heat, and Time is automatically controlled to produce the optimum in a tasty, appealing product.

Pressure

Pressure is basic to this method of food preparation. The pressure is developed from the natural moisture of the food. The patented lid traps this moisture and uses it as steam. Because the steam builds rapidly, a greater part of the natural juices are retained within the food. An operation valve vents excess steam from the pot and maintains constant live steam pressure.

Heat

Heat generated is another important factor of the pressure fryer. Energy savings is realized due to the unit's short frying time, low temperature, and heat retention of the stainless steel cookpot.

Time

Time is important because the shorter time involved in frying foods results in additional economies for the user. Foods are table ready in less time than it would take to fry them in a conventional open-type fryer.

1-2. PROPER CARE

As in any unit of food service equipment, the Henny Penny Pressure fryer does require care and maintenance. Requirements for the maintenance and cleaning are contained in this manual and must become a regular part of the operation of the unit at all times.

1-3. ASSISTANCE

Should you require outside assistance, call your local distributor in your area, or call 1-800-417-8405 or 937-456-8405.

1-4. SAFETY

The Henny Penny Pressure Fryer has many safety features incorporated. However, the only way to ensure a safe operation is to fully understand the proper installation, operation, and maintenance procedures. The instructions in this manual have been prepared to aid you in learning the proper procedures. Where information is of particular importance or safety related, the words DANGER, WARNING, CAUTION, and NOTE are used. Their usage is described below.



The word DANGER indicates an imminent hazard which will result in highly serious injury such as second or third degree burns, loss of sight, and other permanent injuries.

WARNING

The WARNING is used to alert you to a procedure, that if not performed properly, might cause personal injury, such as burns and/or loss of sight, and damage to the fryer.

CAUTION

The word CAUTION is used to alert you to a procedure that, if not performed properly, may damage the fryer, or product.

NOTE

The word NOTE is used to highlight especially important information.

SECTION 2. INSTALLATION

2-1. UNPACKING
INSTRUCTIONS

1. Cut and remove the metal bands from the carton.
2. Remove the carton lid and lift the main carton off the fryer.
3. Remove corner packing supports (4).
4. Cut and remove the metal bands holding the fryer to the pallet.

WARNING

Do not unlatch the lid before completion of steps 5, 6, and 7.

5. Remove the fryer from the pallet. See page 2-2.

WARNING

The fryer weighs approximately 600 lbs. (273 KG). Extreme care should be taken when moving the fryer to prevent personal injury.

6. Load the Counterweight Assembly. See page 2-3.
7. Replace rear cover.
8. Cut warning tags from the lid assembly. The lid may now be unlatched.
9. Prepare the deadweight valve for operation.

CAUTION

The metal shipping support is placed inside the deadweight valve housing to protect the orifice and weight during shipment. This support must be removed prior to installation and start-up.

- A. Unthread the top cap.
- B. Remove the round weight.
- C. Remove and discard the shipping support.
- D. Clean the orifice with a dry cloth.
- E. Replace the weight and secure the top cap.

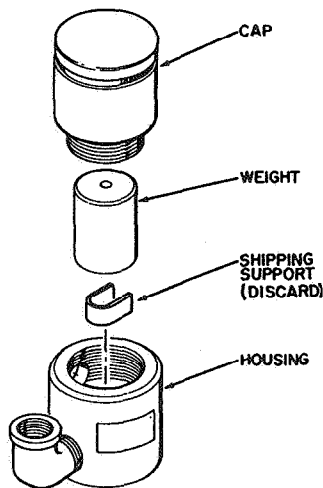

2-1. UNPACKING INSTRUCTIONS (Continued)

10. Unpacking is complete.
11. Open lid and remove packing racks from inside of cookpot.
12. Remove the protective paper from the fryer cabinet. It is necessary to clean exterior surface with a damp cloth.

WARNING

THE FRYER WEIGHS APPROXIMATELY 600 LBS. (273 KG). EXTREME CARE MUST BE TAKEN WHEN MOVING THE FRYER TO PREVENT PERSONAL INJURY.

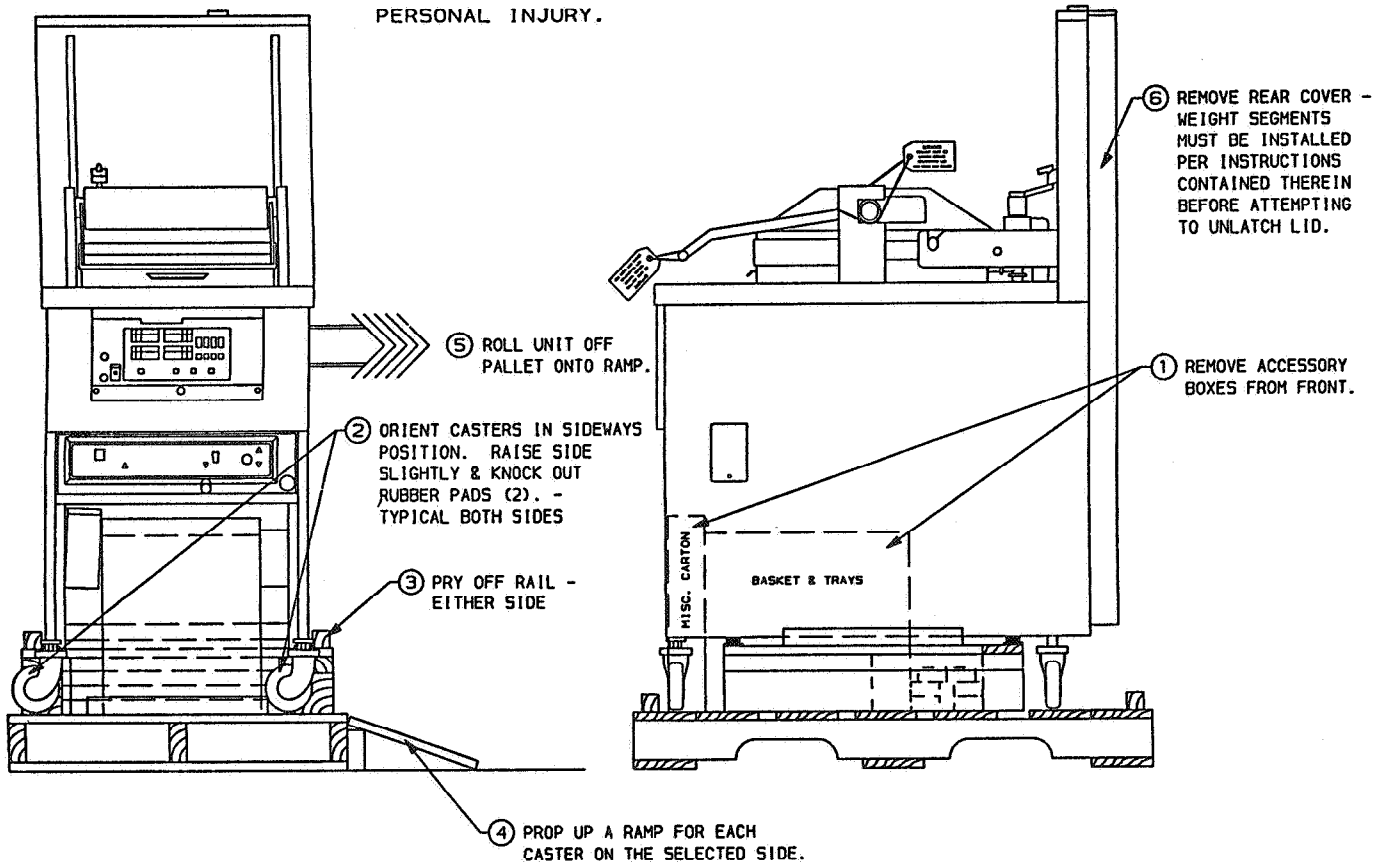

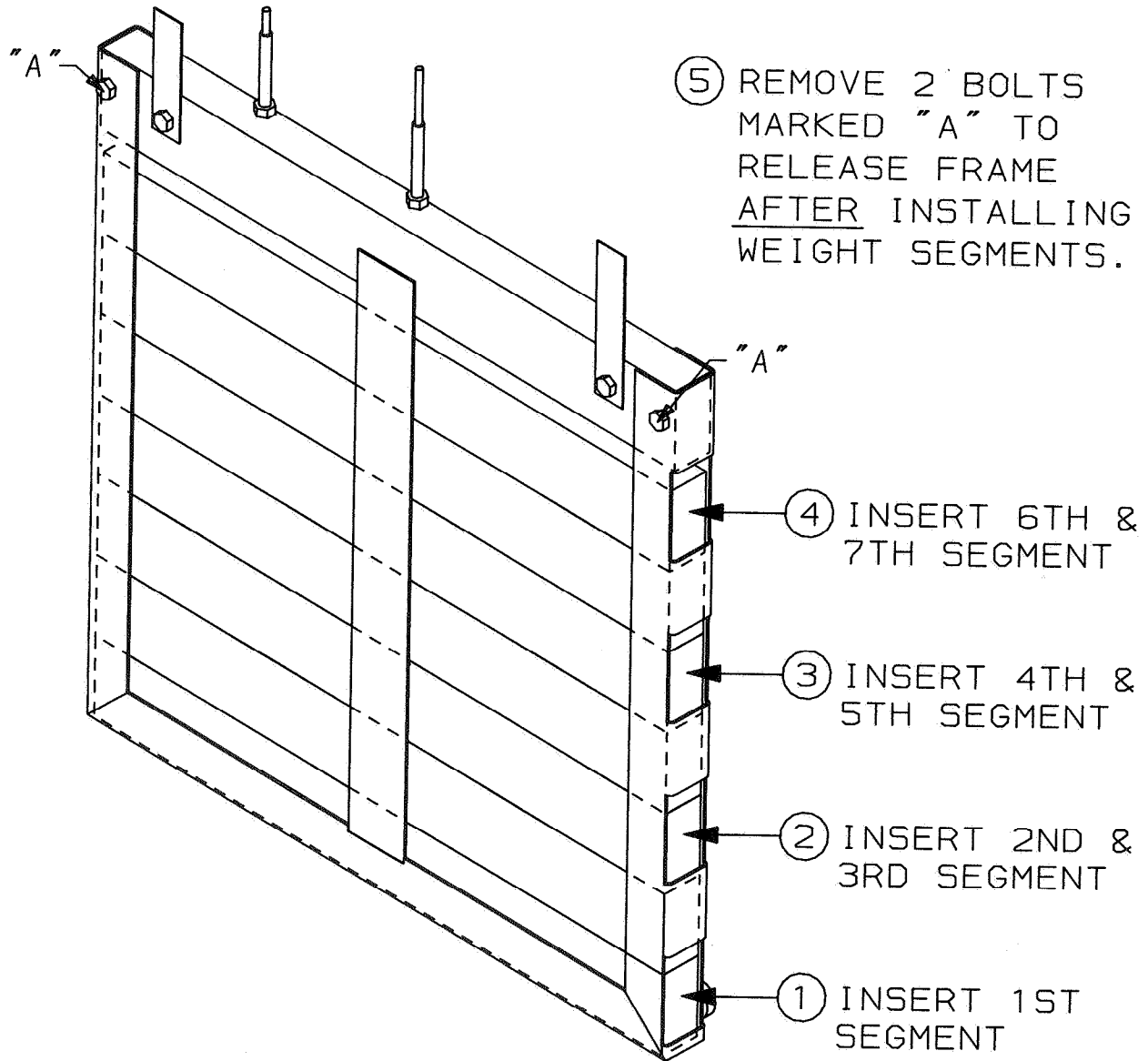

WARNING!

- * EACH WEIGHT SEGMENT WEIGHS APPROXIMATELY 18 LBS. (8.1 KG) - HANDLE WITH CARE.
- * ALL SEGMENTS ARE IDENTICAL.
- * ALL SEGMENTS MUST BE INSTALLED AND SECURED IN THE FRAME BEFORE ATTEMPTING TO UNLATCH LID.

2-2. SELECTING THE FRYER LOCATION

The proper location of the fryer is very important for operation, speed, and convenience. Choose a location which will provide easy loading and unloading without interfering with the final assembly of food orders. Operators have found that frying from raw to finish, and holding the product in a warmer provides fast continuous service. Landing or dumping tables should be provided next to at least one side of the fryer. Keep in mind the best efficiency will be obtained by a straight line operation, i.e. raw in one side and finished out the other side. Order assembly can be moved away with only a slight loss of efficiency.

2-3. LEVELING THE FRYER

For proper operation, the fryer must be level from side to side and front to back. Using a level placed on the flat areas around the frypot collar, adjust the casters until the unit is level.

2-4. VENTILATION OF FRYER

The fryer should be located with provision for venting into adequate exhaust hood or ventilation system. This is essential to permit efficient removal of the steam exhaust and frying odors. Special precaution must be taken in designing an exhaust canopy to avoid interference with the operation of the fryer. Make certain the exhaust hood is designed high enough to allow for proper opening of the fryer lid. We recommend you consult a local ventilation or heating company to help in designing an adequate system.

2-5. ELECTRICAL REQUIREMENTS

The electric fryer is available from the factory wired for 208/120 or 240/120 volts, three phase 60 Hz. service. The power cord may be already attached to the fryer, or provided at installation. Check the data plate on the right side of the fryer to determine the correct power supply.



This fryer must be adequately and safely grounded. Refer to local electrical codes for correct grounding procedures. If fryer is not adequately grounded, electrical shock could result.

A separate disconnect switch with proper capacity fuses or breakers must be installed at a convenient location between the fryer and the power source. It should be an insulated copper conductor rated for 600 volts and 90 °C. For runs longer than 50 feet, use the next larger size wire.

2-6. TESTING THE FRYER

Each Henny Penny pressure fryer was completely checked and tested prior to shipment. However, it is good practice to check the unit again after installation.

2-7. OPERATIONAL CHECKS

1. Cook a round of product.
2. Check to see that the indicator needle in the pressure gauge is reading in the "Operating Zone".

WARNING

Should the pressure gauge read beyond the "Operating Zone" turn the Power/Pump switch to the "OFF" position and refer to the Operation Control Valve Section. Continued use of the unit at this high pressure could result in serious injuries and severe burns.

3. Make sure lid gasket is not leaking, and no steam is coming from safety relief valve.
4. Check the drain valve and fill line check valve
5. At the end of the cook cycle:
 - The control will sound off by beeping.
 - The fryer will automatically depressurize.
6. Push the timer button.
7. When all the pressure has exhausted (observe pressure gauge) open the lid.



DO NOT ATTEMPT TO OPEN LID UNTIL THE PRESSURE DROPS TO ZERO. Opening the lid when the cookpot is pressurized will allow hot shortening and moisture to escape from the cookpot, resulting in severe burns.

8. Let rack hang for 3-5 seconds, then proceed to take out racks of chicken and place onto a bun pan.

**2-7. OPERATIONAL CHECKS
(Continued)**

If all the above functions have been performed satisfactorily the fryer is ready for operation.

WARNING

All operators, as well as maintenance and management personnel, must thoroughly read and understand the Operation Section prior to putting the fryer into operation. Failure to adhere to these instructions could result in serious bodily injury or property damage.

**2-8. INTERNATIONAL
ELECTRICAL
REQUIREMENTS**

Units being used outside the United States may not be shipped with the power cord attached to the unit because of the different wiring codes. The fryers are available from the factory wired for 208, 240, 380 and 415 volts, 3 phase, 50 Hertz service. A terminal block is mounted inside the fryer for the cable wiring. A decal on the inside of the right side panel will help in the wiring of the unit.

To install the power cord, follow these procedures:

1. Remove the side panel from the right side of the unit.
2. Remove the front panel, behind the filter knob and quick disconnect.
3. Thread the cable through the strain relief on the junction box.
4. Attach the wires to the terminal block according to the wiring diagram on the side panel.
5. Pull the slack out of the cable and tighten the screws on the strain relief.
6. Pull the slack out of the cable and secure it with the clamp on the back of the cookpot.

NOTE

Be sure the cable doesn't sag, or it could interfere with the use of the portable filter.

**2-8. INTERNATIONAL
ELECTRICAL
REQUIREMENTS
(Continued)**

7. Pull the slack out of the cable and secure it with the clamp on the frame, at the rear, right leg of fryer.

WARNING

Be sure enough slack is out of the cable so it doesn't extend out past the portable filter stop bracket at the bottom of the fryer frame. The cable could interfere with the portable filter, not allowing it to be pushed all the way in. This could cause hot shortening to spill onto the floor.

8. Wiring the fryer is now complete.

**BOIL-OVER PREVENTION
IN HENNY PENNY FRYERS**



FAILURE TO FOLLOW THESE INSTRUCTIONS CAN RESULT IN SHORTENING OVERFLOWING THE FRYPOT, WHICH COULD CAUSE SERIOUS BURNS, PERSONAL INJURY, FIRE AND/OR PROPERTY DAMAGE.

- THE SHORTENING MAY BE STIRRED **ONLY** DURING THE MORNING START UP PROCEDURE. **DO NOT STIR THE SHORTENING AT ANY OTHER TIME**
- FILTER THE SHORTENING AT LEAST TWICE A DAY
- FILTER ONLY AFTER POWER SWITCH IS OFF
- BRUSH ALL CRACKLINGS FROM FRYPOT SURFACES AND THE COLD ZONE DURING THE FILTERING PROCESS
- MAKE SURE THE FRYER IS LEVEL
- BE CERTAIN THE SHORTENING IS NEVER ABOVE THE UPPER FRYPOT "FILL" LINE
- USE RECOMMENDED PRODUCT LOAD SIZE, 22lbs. (9.9 kg)

FOR ADDITIONAL INFORMATION ON THESE INSTRUCTIONS REFER TO THE HENNY PENNY SERVICE.

**FOR ASSISTANCE CALL THE HENNY PENNY SERVICE DEPARTMENT AT
1-800-417-8405, or 1-937-456-8405.**

SECTION 3. OPERATION

3-1. OPERATING CONTROLS

This section describes the functions of all operating controls and their components.

Item	Description	Function
1	Control Decal	The control decal is a self-adhesive decal which displays the desired functions.
2	Menu Board	The menu board displays the products that have been programmed within the control.
3	Menu Indicator	The menu indicators, when illuminated, point to the product cycle the control is in.
4	Done Indicator	This indicator shows the operator the cooking cycle is completed.
5	Digital Display	The digital display is a LED type display which shows the temperature of the shortening and the timer countdown of the frying cycle.
6	Ready Light	The ready light indicates the shortening has reached operating temperature and the operator may drop product.
7	High Limit Light	This light will illuminate in the event the manual reset high limit has tripped. This indicates the shortening temperature has exceeded the safe operating limit.
8	Change Switch Indicators	These indicators, when illuminated, show which part of the display is functional for programming such as increasing or decreasing temperature, time, etc.
9	Pressure Light	When illuminated, shows the solenoid is closed which allows pressure to build.
10	Key Switch	When in the COOK position the unit is in the normal operation mode. In the PROGRAM position the unit is in the program mode.
11	Power Switch	This switch is a sealed illuminated rocker type switch. When in the COOK position, applies power to the control. When in the PUMP position applies power to the pump motor.
12	Timer Switch	The timer switch is used to start, stop, or abort a cooking cycle.

Item	Description	Function
13	Reset Usage Switch (Program Mode Only)	This switch resets the total number of cycles that have been cooked either in one product or in all products.
14	Change Switches (Program Mode Only)	These switches change the value of the displayed number. Such as increasing or decreasing the time of a cook cycle, or increasing or decreasing the temperature of a cook cycle.
15	Review Usage Switch (Program Mode Only)	By depressing this switch the display will show you the number of cook cycles that have been cooked for a particular product.
16	Select Function Switch (Program Mode Only)	This switch will change the function that is being programmed such as time, temperature, alarm, etc.
17	Select Product Switch	This switch selects the product you wish to cook or program.
18	Select Time Switch	The select time switch selects the interval within a product. There are ten intervals per product.
19	Function Display (Program Mode Only)	The function display will show you the function you are in when programming.

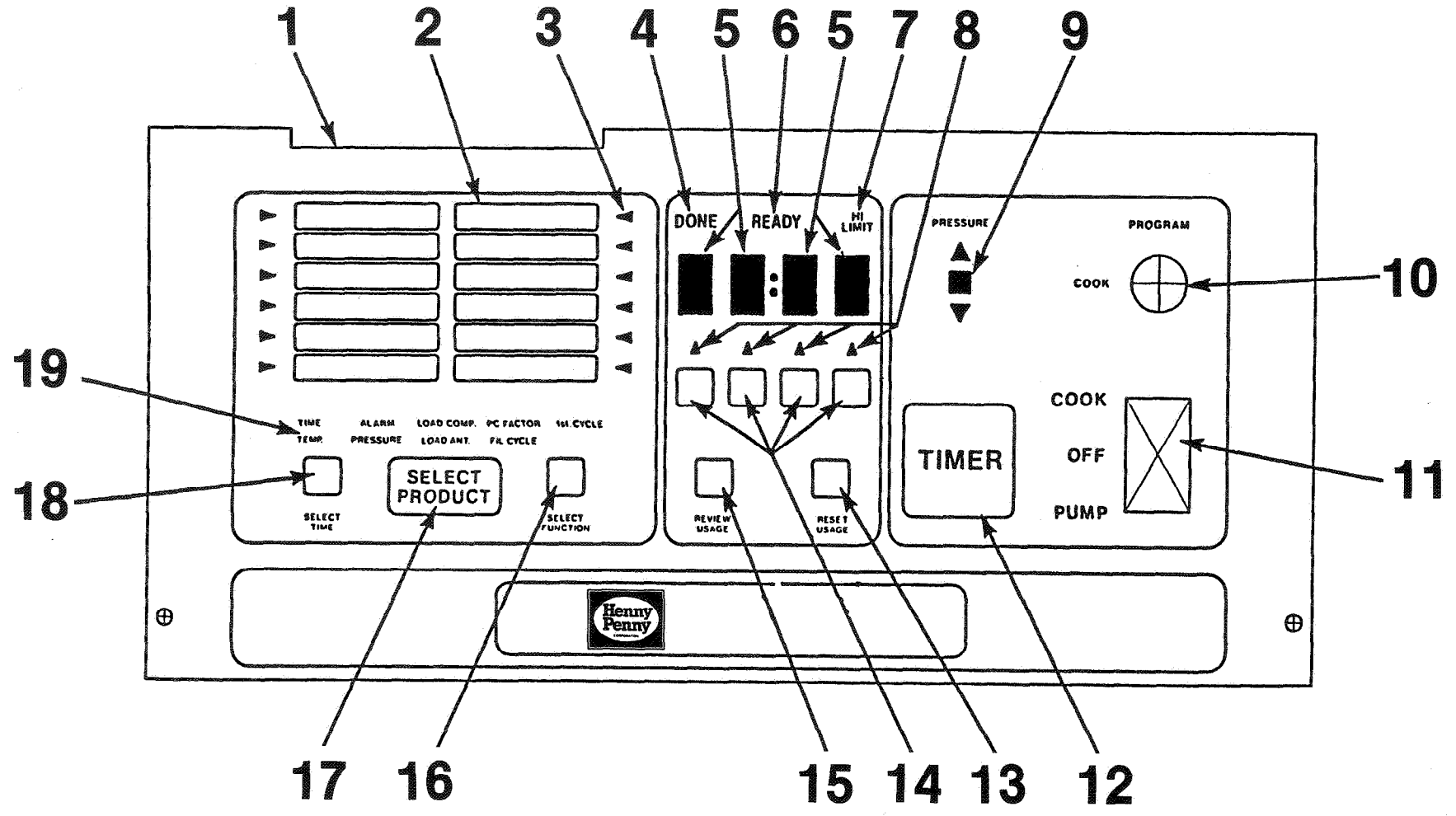

3-1. OPERATING CONTROLS (Continued)

<p>1. Cook/Pump Switch</p>	<p>This is a three-way switch with center “OFF” position. Move the switch to the position marked “POWER” to operate the fryer. Move the switch to the position marked “PUMP” to operate the filter pump. Certain conditions must be met prior to operation of the filter pump. These conditions are covered later in this section.</p>
<p>2. Cookpot</p>	<p>This reservoir holds the cooking shortening, and is designed to accommodate the Heat Exchanger, 8 head of product and an adequate cold zone for collection of cracklings.</p>
<p>3. Cooking Rack</p>	<p>This stainless steel rack consists of five baskets that contain the food product during and after frying.</p>
<p>4. Lid Gasket</p>	<p>The lid gasket provides the pressure seal for the cookpot chamber.</p>
<p>5. Operating Valve</p>	<p>The dead weight style operating pressure relief valve is used to maintain a constant level of steam pressure within the cookpot. Any excess steam pressure is vented through the exhaust stack.</p> <p style="text-align: center;">NOTE</p> <p>Remove the dead weight cap, and clean the cap, weight, and orifice, once a day to prevent over pressurization of the cookpot</p>
<p>6. Safety Relief Valve</p>	<p>The safety relief valve is an ASME approved spring loaded valve set at 14.5 psi (999 mbar). In the event the operation valve becomes obstructed, this safety valve will release excess pressure, keeping the cookpot chamber at 14.5 psi (999 mbar). If this occurs, turn the Power/Pump switch to the “OFF” position to release all pressure from the cookpot.</p>
<p>7. Safety Relief Valve Ring</p>	<p>THE RING IS NOT TO BE PULLED.</p> <div style="text-align: center;">  <p>DANGER</p> </div> <p>Severe burns from the steam will result.</p>
<p>8. Gauge</p>	<p>The pressure gauge indicates the pressure inside the cookpot.</p>

<p>9</p>	<p>Solenoid Valve</p>	<p>The solenoid valve is an electro-mechanical device that causes pressure to be held in the cookpot.</p> <p>The solenoid valve closes at the beginning of the frying cycle and is opened automatically at the end of the frying cycle. If this valve should become dirty or the teflon seat nicked, pressure will not build up and it must be repaired per the maintenance section.</p>
<p>10</p>	<p>Drain Valve</p>	<p>The drain valve is a two-way ball valve. It is normally in the closed position. Pull the knob out to drain the shortening from the cookpot into the filter drain pan.</p> <div data-bbox="987 821 1228 1000" style="text-align: center;"> <p>DANGER</p> </div> <p>DO NOT OPEN THE DRAIN VALVE WHILE COOKPOT IS UNDER PRESSURE. Hot shortening will exhaust from this valve. Severe burns will result.</p>
<p>11</p>	<p>Drain Interlock Switch</p>	<p>The drain interlock switch is a microswitch that provides protection for the cookpot in the event an operator inadvertently drains the shortening from the cookpot while the main switch is in the COOK position. The switch is designed to automatically shut off the heat when the drain valve is opened.</p>
<p>12</p>	<p>Condensation Drain Pan</p>	<p>The condensation drain pan is the collection point for the condensation formed on the lid liner and within the steam exhaust system. It must be removed and emptied periodically.</p>

3-2. LID OPERATION

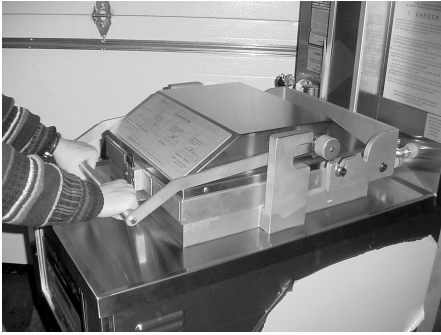

1



2



3



4



5

To close lid:

1. Lower the lid until lid latches into place.
2. Pull lid handle forward until it stops.
3. Lift up on the lid handle until it stops.
4. Bring lid handle out towards you until it stops.
5. Push lid handle down, locking lid in place.



DO NOT ATTEMPT TO OPEN LID UNTIL THE PRESSURE DROPS TO ZERO. Lid is locked when fryer is under pressure. Do not attempt to force the lid latch or open the lid while under pressure. Opening the lid when the cookpot is pressurized will allow hot shortening and moisture to escape from the cookpot, resulting in severe burns.

3-2. LID OPERATION (Continued)

To open lid:



1



2



3

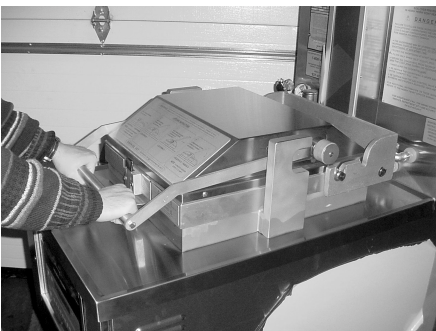

4



5



DO NOT ATTEMPT TO OPEN LID UNTIL THE PRESSURE DROPS TO ZERO. Lid is locked when fryer is under pressure. Do not attempt to force the lid latch or open the lid while under pressure. Opening the lid when the cookpot is pressurized will allow hot shortening and moisture to escape from the cookpot, resulting in severe burns.

1. Gently raise handle until it stops.
2. Push handle back until it stops.
3. Lower handle.



DO NOT raise the lid with the handle in the up position. Lower the handle before attempting to raise the lid, or damage to the lid could result.

4. Push handle back.
5. Unlatch the front lid latch and raise lid with handle.

**3-2. LID OPERATION
(Continued)**



Kickstand

Tilt the lid back for ease of filtering or servicing.

1. With the lid completely raised, remove the Cooking Rack from lid.
2. Using the handle, tilt lid back until the metal “kickstand” fits in the groove in the lid support. (See photo).

WARNING

Make sure the “kickstand” is secure in the groove of the lid support, or severe injuries could result.

**3-3. FILLING OR ADDING
SHORTENING**

level Indicator lines

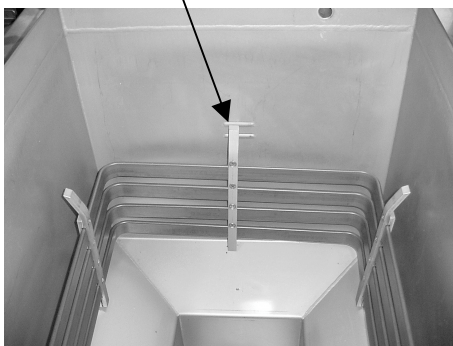

1. It is recommended that a high quality frying shortening be used in the pressure fryer. Some low-grade shortenings have high moisture content and will cause foaming and boiling over.
2. If a solid shortening is used, it can be melted into a liquid first, then poured into the cookpot. Attempting to melt solid shortening in the cookpot may cause burning or scorching of the fresh shortening.

WARNING

GLOVES SHOULD BE WORN AND CARE MUST BE TAKEN WHEN POURING HOT SHORTENING. Severe burns could result. Also, when adding fresh shortening to existing shortening, care must be taken to avoid splashing or severe burns could result.

3. The electric model requires 100 lbs. The pot has two level indicator lines inscribed on the rear wall of the frypot which show when the heated shortening is at the proper level. Maintain hot shortening at the upper level indicator line. Add fresh shortening as needed.
4. Cold shortening should be filled to 1/2 inch below lower level indicator line.

3-4. CARE OF THE SHORTENING

1. To protect the shortening when the fryer is not in immediate use, the fryer should be put into the Idle Mode.
2. Frying breaded products requires filtering to keep the shortening clean. The shortening should be filtered at least twice a day; after lunch rush and at the end of the day.
3. Maintain hot shortening at the upper level indicator line. Add fresh shortening as needed.



CAUTION

The shortening level must always be above the heating elements when the fryer is heating, and up to the upper level indicator line on the frypot. Failure to follow these instructions could result in a fire and/or damage to the fryer.



With prolonged use, the flashpoint of shortening is reduced. Discard shortening if it shows signs of excessive smoking or foaming. Serious burns, personal injury, fire, and/or property damage could result.

To avoid shortening overflowing the frypot, do not overload the basket with product, or place product with extreme moisture content into basket. The recommended product load size is 22 lbs (9.9 kg.) Serious burns, personal injury, fire and/or property damage could result.

3-5. START-UP (Preheat) PROCEDURE

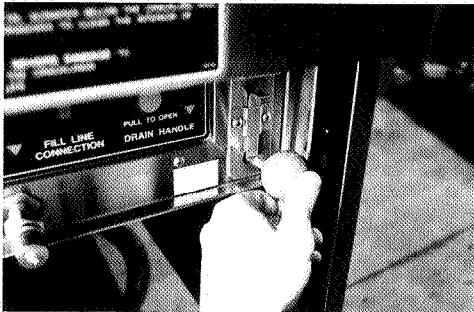

The following procedures should be followed on the initial start-up of the fryer each time the fryer is brought from a cold, or shut down, condition back into operation.

1. Check to see that all of the control switches are turned off.
2. Be sure the drain valve is CLOSED.
3. Remove carrier and baskets from lid and tilt lid back (see section 3-2).
4. Fill the cookpot to a level at ½ inch below the bottom fill line (see section 3-3).
5. Connect power to fryer.
6. Move the Cook/Pump switch to the "COOK" position.
7. Select the desired product using the Select Product switch. The red indicator will be illuminated beside the product.
8. When the desired temperature has been reached the Ready Light will illuminate. Stir the shortening at this time to stabilize the temperature. Be sure to agitate the shortening in the "cold zone" in the bottom of the cookpot.



Do not stir the shortening at any other time except at initial "cold" start-up. Failure to follow these instructions can result in shortening overflowing the cookpot which could cause serious burns, personal injury, fire, and/or property damage.

9. After the shortening temperature has stabilized for a minimum of 30 minutes, check the shortening temperature using a good deep fat thermometer (Henny Penny part number 12106). If off more than 5°F, refer to the maintenance section.
10. If the shortening was not filtered the night before at shut-down, it should be filtered now, after the shortening reaches the frying temperature (325°F) and before the fryer is used.

3-5. START-UP (Preheat) PROCEDURE (Continued)



If the shortening temperature exceeds 420°F immediately shut off the power at the main circuit breaker and have the fryer repaired. If shortening (temperature) exceeds its flashpoint, fire will occur, resulting in severe burns and/or property damage.

11. Raise the lid up and place carrier and baskets onto lid.
12. Lower lid and emerse baskets into shortening, then raise lid. This will keep the product from sticking to the baskets. You are now ready to start frying.

NOTE

Do not permit the fryer to set for an extended period of time at high temperature (325°F or above), because the shortening will break down much sooner. When the fryer is not being used for frying, put the controls to the "IDLE" position.

3-6. FRYING PROCEDURES

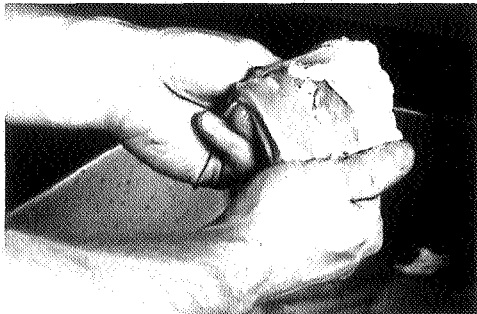

1. Take the chicken parts, 2, 4, 6, or 8 cut-up chickens, from the cooler and place in a scullery sink. Wash the chicken and at this point break the thigh from the joint of the backbone.
2. Remove any excess fat from the thigh.
3. Remove the chicken from the water and drain slightly but allow the parts to remain moist.
4. If a breading machine is used, fill the breading drum with approximately 8 to 10 pounds of PHT Fryer Mix. Feed the moist but drained pieces into the chute at one end of the breader.

3-6. FRYING PROCEDURES (Continued)

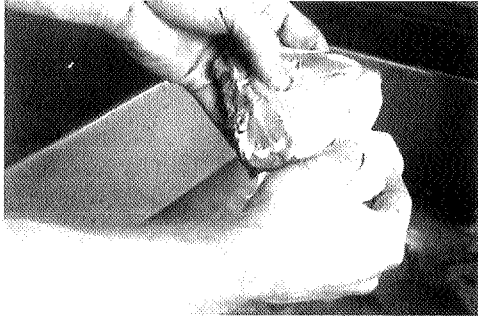

5. Allow the breaded pieces to fall onto a tray as they come out of the breeder drum. (More breading may be needed if a large amount of product is to be breaded.)
6. If a breading machine is not used, the food should be placed in the dry mix and hand tumbled so that each piece of food is completely covered.
7. Knock off any excess breading and place the breaded product on a tray for cooler storage. Place a damp cloth over the breaded food to retain moisture. The breaded food should be held for a minimum of 30 minutes before frying, so that it can absorb spices from the breading and so that breading can better adhere to the product.
8. Prepare fryer as per start-up procedures.
9. Be sure the product selector is on chicken.
10. Lower the lid and baskets into shortening, then raise them to grease the baskets.
11. Remove baskets and place product into baskets - the larger pieces to the outside edge of baskets.
12. Place the baskets onto carrier, starting with the bottom rack and working up.
13. Place cover grid on top rack to prevent pieces from floating.
14. Lower lid and baskets and lock lid down.
15. Push the timer switch.
16. Within a few minutes, the pressure gauge should increase to the operation zone. If it does not, recheck the procedures and then refer to the troubleshooting section.
17. When the timer reaches zero the fryer will automatically depressurize and the control will beep. Push the timer switch to reset the controls.



Check the pressure gauge reading. Do not attempt to open the lid until the pressure drops to zero. Opening the lid when the cookpot is pressurized will allow hot shortening and moisture to escape from the cookpot resulting in severe burns to the operator.

**3-6. FRYING PROCEDURES
(Continued)**

18. After the pressure drops to zero, open the lid.
19. Let baskets hang for approximately 15 seconds before removing the baskets.
20. Place the product into a warming cabinet immediately.
21. Before frying the next load, allow time for the shortening to reheat. (Wait until the ready light comes on.)

3-7. FILTERING

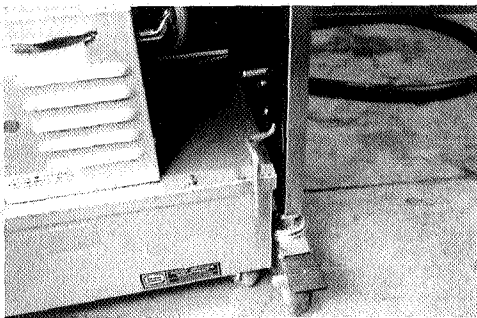
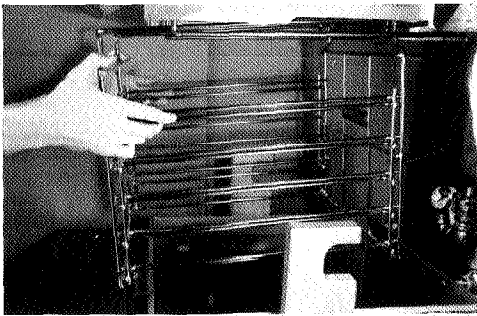

Frying breaded food requires frequent filtering. Taste the cold shortening every day for flavor. Watch the shortening for foaming during frying cycles. Discard the shortening as soon as it shows signs of foaming. Clean the frypot as follows each time the shortening is changed or filtered.

1. Turn the power switch to the "OFF" position.

NOTE

The best results are obtained when the shortening is filtered at the normal frying temperature.

2. Remove carrier from lid of the fryer.

WARNING

Rack may be hot. Burns could result.

3. Lower the lid to the lid stop bracket and tilt the lid back and into an upright position (see section 3-2).
4. Use a metal spatula to scrape any build-up from the sides of the frypot. Do not scrape heating element.
5. Roll the filter unit under the fryer, until the latch located on the front, right leg of the fryer, secures the filter unit in place.



The filter unit must be in the proper position beneath the drain valve. This will prevent the splashing of shortening on the floor. This splashing could result in severe burns.

3-7. FILTERING
(Continued)

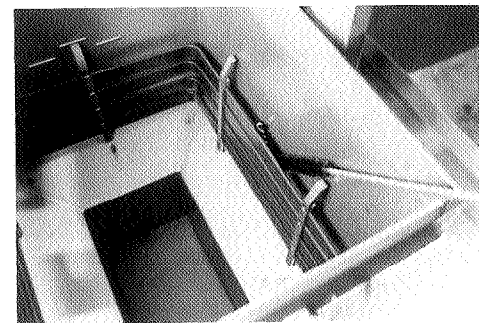
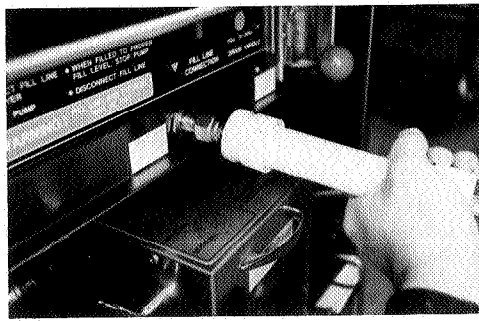
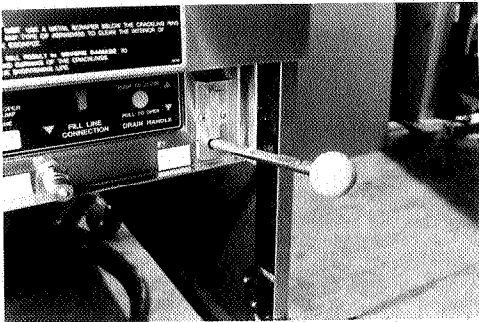

6. Open the drain valve fully by pulling the drain valve knob all the way out.
7. As the shortening drains from the cookpot, use brushes (Henny Penny part number 12105 includes both brushes) to scrape and clean the side of the cookpot and the heating elements. If the drain fills with breading, use the white brush to push the breading into the filter pan.
8. When all of the shortening has drained, scrape or brush the sides and the bottom of the cookpot.
9. Rinse the frypot as follows:
 - A. Close the drain valve.
 - B. Connect hose of filter unit to the fryer.
 - C. Plug filter unit into the fryer.



Lower the lid so that the very first surge of shortening will not splash up or over the top of the cookpot, causing severe burns.

- D. Turn the cook/pump switch to the "PUMP" position. Carefully open lid to see if shortening is returning properly. Fill cookpot 1/3 full, then turn pump off.



If there are air bubbles coming up in the shortening, it is possible that the filter connection union on the filter tube line is not tightened properly. If so, turn off the pump. Use gloves to tighten the union. Severe burns could result.

- E. Wash down and scrub the sides of cookpot. Use "L" brush to clean the heating elements.
- F. After the sides and bottom are cleaned, open the drain valve and let shortening drain out, then close drain valve.

**3-7. FILTERING
(Continued)**

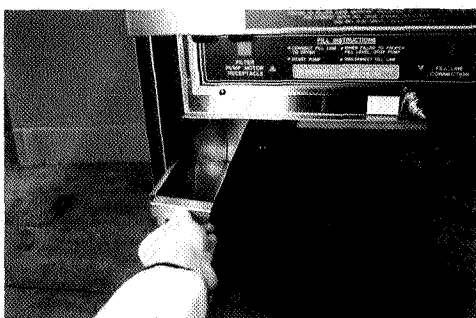
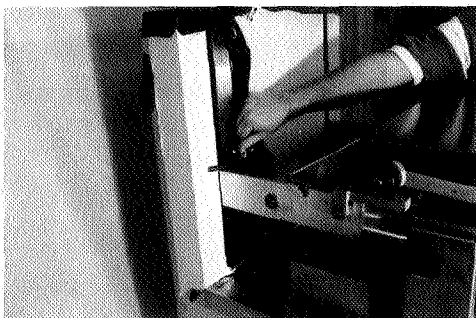

10. Lower the lid down to the lid stop bracket during the first surge of pumping and pump all the shortening out of the filter pan and back into the frypot.
11. When the pump is pumping air only, the shortening in the cookpot will appear to be boiling. Move the main power switch to the "OFF" position.

NOTE

When the appearance of boiling occurs, immediately turn the pump off. This will prevent aeration of the shortening, therefore increasing shortening life.

12. Check the level of the shortening in the cookpot. Add fresh shortening if necessary, until it reaches the point between the level indicators.
13. After completing the filtering operation, empty and replace the condensation drain pan.
14. If frying is to be continued at this time, move the main power switch back to the "COOK" position, and allow time for reheating of the shortening.

3-8. CHANGING THE FILTER ENVELOPE

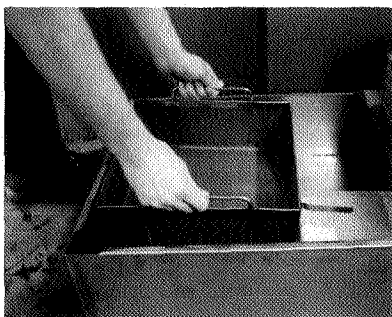
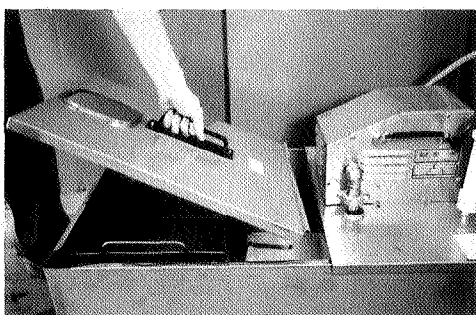

The filter envelope should be changed after 10-12 filterings or whenever it becomes clogged with crumbs. Proceed as follows:

1. Unplug portable filter (PF-180) from cooker and roll filter unit out from under the cooker.
2. Remove back cover from filter unit and remove crumb basket. Discard crumbs and clean thoroughly with soap and water. Rinse thoroughly with hot water.
3. Unscrew dairy union from standpipe and remove filter head assembly from filter pan.



This union will be hot. Use protective glove or cloth, or severe burns will result.

3-8. CHANGING THE FILTER ENVELOPE (Continued)

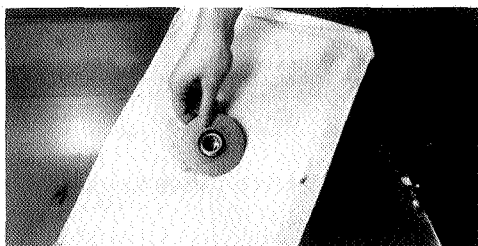
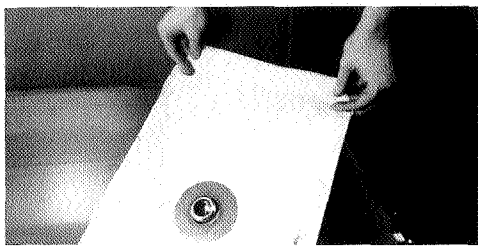
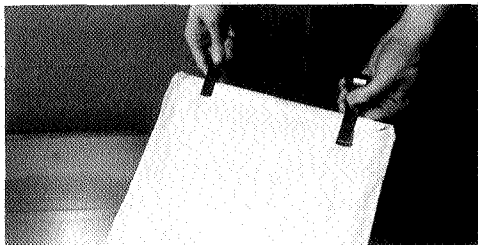
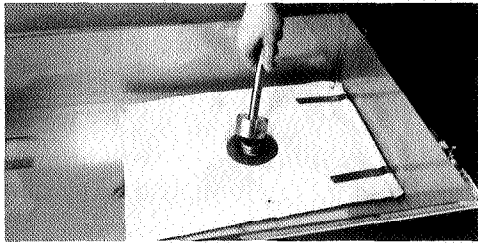
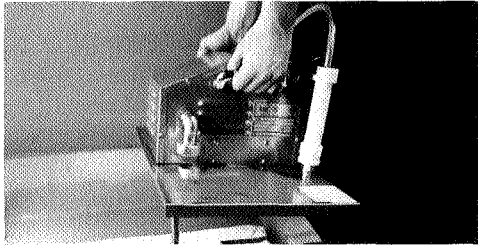
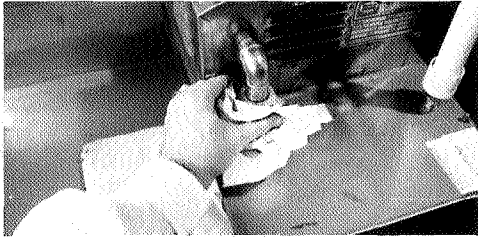

4. Lift the screen assembly from the drain pan.
5. Wipe the shortening and crumbs from the drain pan. Clean the drain pan with soap and water. Thoroughly rinse with hot water.
6. Unthread the suction standpipe from the screen assembly.
7. Remove filter clips and discard the filter envelope.
8. Clean the top and bottom filter screen with soap and water. Rinse thoroughly with hot water.

CAUTION

Be sure that the filter screens, crumb catcher, filter clips, and the suction standpipe are thoroughly dry before assembly of filter envelope, as water will dissolve the filter paper.

9. Assemble the top filter screen to the bottom filter screen.
10. Slide the screens into a clean filter envelope.
11. Fold the corners in, then double fold the open end.
12. Clamp the envelope in place with the two filter retaining clips.
13. Place large washer on top of filter paper and screw on the suction standpipe assembly.
14. Place complete filter screen assembly back into filter drain pan.
15. Place filter assembly over suction standpipe assembly, and connect filter union by hand. Do not use a wrench to tighten.
16. Place crumb basket into position in the back of the filter pan and place cover over it.
17. Portable filter is now ready to be slid under the cooker for filtering.

3-9. FILTER PUMP PROBLEM PREVENTION

The following steps will help prevent filter pump problems:

1. Make certain the filter paper envelope is properly installed over the filter screens. Make sure the open end of the envelope is properly folded over and clamped in place with the retaining clips, so that the envelope is sealed and crumbs cannot enter.
2. Make sure the filter valve is kept closed at all times during frying.
3. Make sure all the shortening has been pumped from the filter lines and the pump by allowing the filter pump motor to run until the shortening in the cookpot appears to be bubbling or boiling.

The filter motor is equipped with a manual reset button in the event the motor's thermal protector actuates. This reset button is located on the front of the filter head assembly, behind a hinged circular door. Wait approximately 5 minutes before attempting to reset this protector device.

NOTE

Use steady, hard pressure on the reset button until a definite "click" is heard. The button takes some force to reset.

WARNING

To prevent burns caused by splashing shortening, the unit's power cord must be unplugged before resetting the filter pump motor's manual reset protection device.

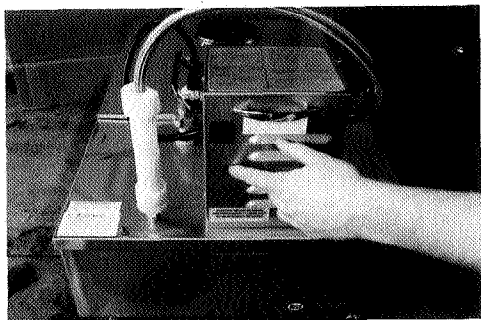

3-10. CLEANING THE FRYPOT

After the initial installation of the fryer, as well as before every change of shortening, the cookpot should be thoroughly cleaned as follows:

1. Turn the main power switch OFF.



The filter drain pan must be in position under the drain valve to prevent splashing or spilling of hot liquids. Failure to do so will result in splashing and severe burns.

2. If hot shortening is present in the cookpot, it must be drained by slowly pulling the drain valve knob.
3. Close the drain valve. Discard the shortening in the filter pan. Roll the empty filter pan under the fryer.
4. Lower the lid to the lid stop bracket and tilt lid back, so that the lid won't interfere with cleaning.
5. Fill the cookpot to the level indicators with hot water. Add 8 to 10 ounces of fryer cleaner (Henny Penny part number 12101) to the water and mix thoroughly.

WARNING

Always wear safety goggles or face shield and protective rubber gloves when cleaning the cookpot, as the cleaning solution is highly alkaline. Avoid splashing or other contact of the solution with eyes or skin. Severe burns or blindness could result. Carefully read the instructions on the cleaner. If solution comes in contact with eyes, rinse thoroughly with cool water and see a physician immediately.

6. Enter Boil Out mode. (See page 6-8.)



NEVER PRESSURIZE FRYER TO CLEAN. Leave lid open. Water under pressure is super heated and will cause severe burns if it comes in contact with skin.

3-11. CLEANING THE FRYPOT (Continued)

WARNING

DO NOT let the cleaning solution boil. If the cleaning solution in the cookpot starts to foam and boil over, DO NOT TRY TO CONTAIN IT BY CLOSING THE FRYER LID or severe burns could result.

7. Using the fryer brush (Henny Penny part number 12105) scrub the inside of the cookpot, the lid liner, and around the counter-top of the fryer.

CAUTION

Do not use steel wool, other abrasive cleaners or cleaners/sanitizers containing chlorine, bromine, iodine or ammonia chemicals, as these will deteriorate the stainless steel material and shorten the life of the unit.

Do not spray the unit with water, such as, with a garden hose. Failure to follow this caution could cause component failure.

8. After cleaning, turn off the main power switch. Open the drain valve and drain the cleaning solution from the cookpot into the drain pan and discard.
9. Close the drain valve and refill the cookpot with hot water to proper level.
10. Add approximately 16 ounces of distilled vinegar and heat the solution to no more than 195°F (91°C).
11. Using a clean brush, scrub the interior of the cookpot and lid liner. This will neutralize the alkaline left by the cleaning compound.
12. Drain the vinegar rinse water and discard.
13. Rinse down the cookpot, using clean hot water.
14. Thoroughly dry the drain pan, and the cookpot interior.

NOTE

Make sure the inside of the cookpot, the drain valve opening, and all parts that come in contact with the new shortening are as dry as possible.

15. Refill the fryer with fresh shortening

3-11. SEASONAL SHUTDOWN

1. Drain and clean the frypot.
2. Turn the main circuit breaker off and unplug the electrical cord if possible.
3. Close the lid.
4. Remove and clean condensation drain pan.

3-12. CLEANING THE OPERATING VALVE

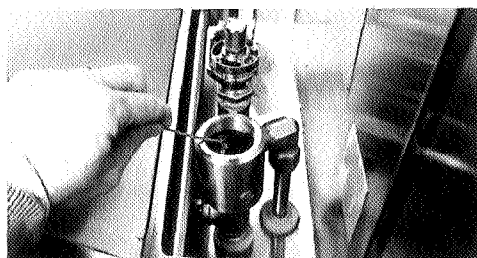
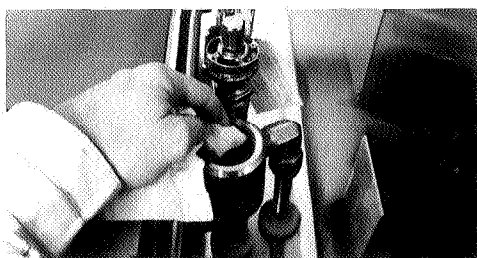
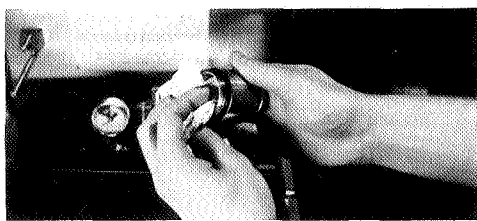
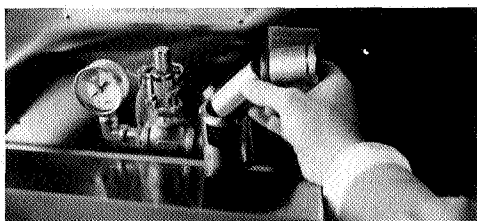

At the end of each day, the operating valve must be cleaned as follows:

1. Turn the COOK/PUMP switch to OFF. Be sure all pressure has been released and open the lid.
2. Unscrew the valve cap and remove the cap and weight.

WARNING

Use gloves. Valve cap may be very hot and burns could result.

3. Clean the cap and weight in hot detergent water. Make certain to thoroughly clean the inside of the valve cap and the weight.
4. Clean the exhaust tube with stainless steel brush (Henny Penny part number 12147).
5. Clean orifices and the inside of the valve body with a clean lint free cloth.
6. Dry the weight and valve cap.
7. Replace weight and valve cap. Hand tighten the cap.

**3-13. NIGHT CLOSING
PROCEDURES**

At the end of each day or shift, perform the following procedures:

1. Move the COOK/PUMP switch to the OFF position.
2. Filter the shortening.
3. Place racks and carrier in sink for cleaning.
4. Clean operating valve per previous paragraph.

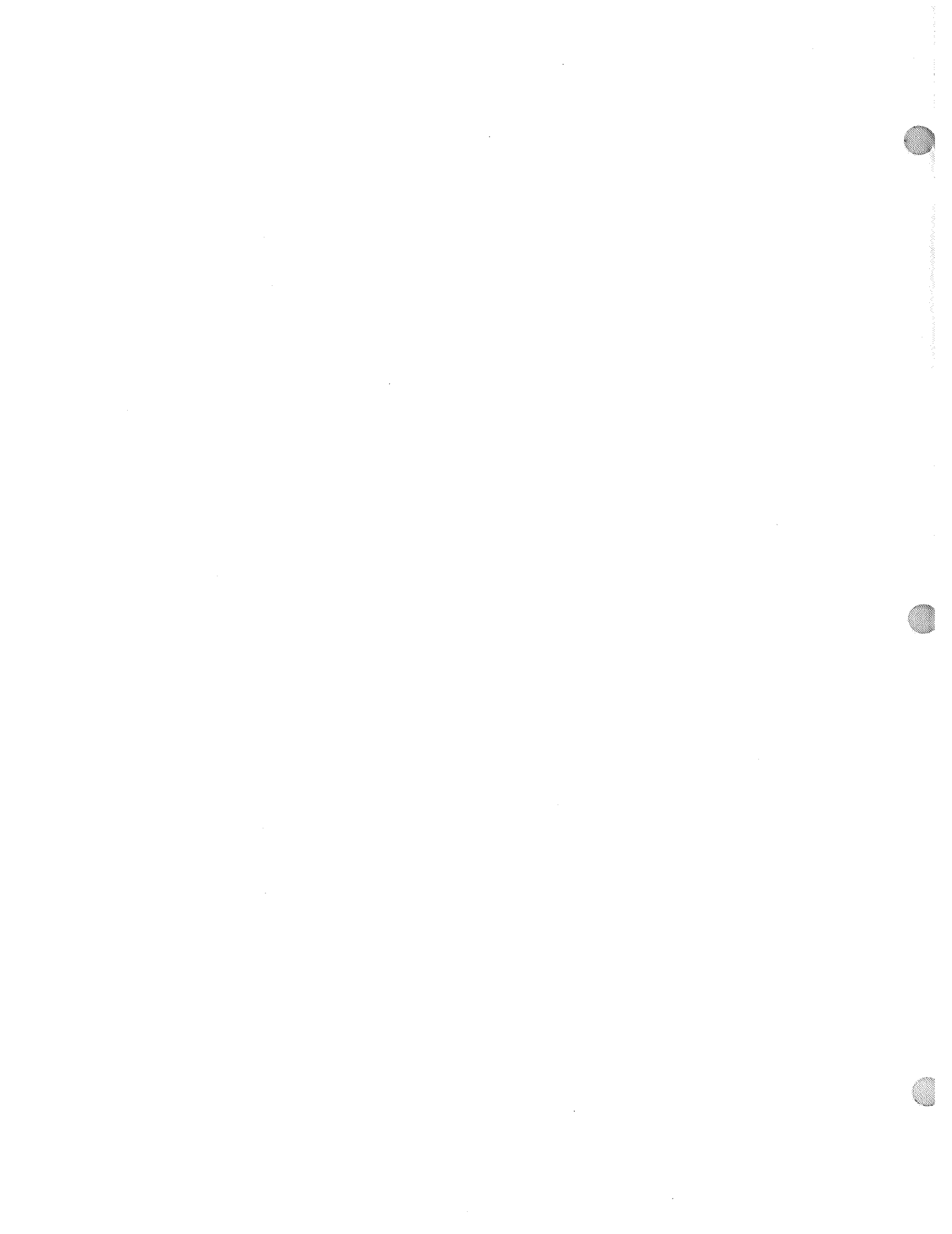

SECTION 4. TROUBLESHOOTING**4-1. INTRODUCTION**

This section provides troubleshooting information in the form of an easy to read table.

If a problem occurs during the first operation of a new fryer, recheck the installation per the Installation Section of this manual.

Before troubleshooting, always recheck the operation procedures per Section 3 of this manual.

4-2. TROUBLESHOOTING

To isolate a malfunction, proceed as follows:

1. Clearly define the problem (or symptom) and when it occurs.
2. Locate the problem in the Troubleshooting table.
3. Review all possible causes. Then, one-at-a-time work through the list of corrections until the problem is solved.
4. Refer to the maintenance procedures in the Maintenance Section to safely and properly make the checkout and repair needed.

WARNING

If maintenance procedures are not followed correctly, injuries and/or property damage could result.

Problem	Cause	Correction
COOKING SECTION		
Product Color Not Correct: A. Too Dark	<ul style="list-style-type: none"> • Temperature too high. • Shortening too old. • Shortening too dark. • Breeding product too far in advance. • Wrong cook button pushed. 	<ul style="list-style-type: none"> • Check temperature setting in the program mode. See section on programming. • Remove and replace defective probe. • Change shortening. • Filter shortening. • Change shortening. • Bread product closer to actual frying period. • Be sure to select the correct product to be cooked.
B. Too Light	<ul style="list-style-type: none"> • Temperature too low. • Fryer incorrect preheat. • Slow fryer heat-up/recovery. • Wrong cook button pushed. 	<ul style="list-style-type: none"> • Check temperature setting. • Remove and replace defective probe. • Allow proper preheat time. • Refer to heating elements in the maintenance section. • Be sure to select the correct product to be cooked.
C. Product Greasy	<ul style="list-style-type: none"> • Shortening old. • Temperature too low. • Wrong cook button pushed. • Cookpot overloaded. • Product not removed from cookpot immediately after depressurization. 	<ul style="list-style-type: none"> • Replace shortening. • Check temperature setting. • Temperature not recovered when product was dropped in cookpot. • Remove and replace defective probe. • Be sure to select the correct product to be cooked. • Reduce cooking load. • Remove product immediately after depressurization of the cookpot.

Problem	Cause	Correction
COOKING SECTION (Continued)		
<p>B. Too Light</p>	<ul style="list-style-type: none"> • Temperature too low. • Fryer incorrect preheat. • Slow fryer heat-up/recovery. • Wrong cook button pushed. 	<ul style="list-style-type: none"> • Check temperature setting. • Remove and replace defective probe. • Allow proper preheat time. • Refer to heating elements in the maintenance section. • Be sure to select the correct amount of product to be cooked.
<p>C. Product Greasy</p>	<ul style="list-style-type: none"> • Shortening old. • Temperature too low. • Cookpot overloaded. • Product not removed from cookpot immediately after end of cycle. 	<ul style="list-style-type: none"> • Replace shortening. • Check temperature setting. • Temperature not recovered when product was dropped in cookpot. • Remove and replace defective probe. • Reduce cooking load. • Remove product immediately after end of cycle.
<p>D. Spotted Product</p>	<ul style="list-style-type: none"> • Improper separation of the product. • Breading not uniform on the product. • Burned breading particles on product. • Product sticking together. 	<ul style="list-style-type: none"> • Load product into basket properly. • Sift breading regularly. • Separate product during breading. • Filter the shortening more frequently. • Separate product prior to pressure cooking.

Problem	Cause	Correction
COOKING SECTION (Continued)		
<p>E. Dryness of Product</p>	<ul style="list-style-type: none"> • Moisture loss prior to cooking. • Overcooking the product. • Low operating pressure. • Wrong cook button pushed. 	<ul style="list-style-type: none"> • Use fresh products. • Reduce cooking time. • Reduce cooking temperature. • Check pressure gauge reading, check for pressure leaks. • Be sure to select the correct product to be cooked.
<p>Product Flavor (Taste):</p> <p>A. Salty Taste</p>	<ul style="list-style-type: none"> • Breading mixture is too salty. • Incorrect choice of breading. 	<ul style="list-style-type: none"> • Sift breading after each use. • Incorrect breading mixture. • Discard old breading. • Use breading designed for the desired product.
<p>B. Burned Taste</p>	<ul style="list-style-type: none"> • Burned shortening flavor. • Cookpot not properly cleaned. 	<ul style="list-style-type: none"> • Replace shortening. • Drain and clean cookpot.
<p>C. Bland Taste</p>	<ul style="list-style-type: none"> • Raw product not fresh. • Breading mixture incorrect for product (spice content too low). • Cooking temperature too high (spice flavors lost). 	<ul style="list-style-type: none"> • Use fresh raw products. • Use breading designed for desired product. • Check temperature.

Problem	Cause	Correction
COOKING SECTION (Continued)		
D. Rancid Taste	<ul style="list-style-type: none"> • Shortening too old. • Non compatible products cooked within the same shortening. • Infrequent filtering. • Raw product not fresh. 	<ul style="list-style-type: none"> • Replace shortening, and follow recommended care and use of shortening. • Replace shortening. • Use compatible products, and follow recommended care and use of shortening. • Replace shortening, and follow recommended care and use of shortening. • Use fresh product.
General: A. Meat Separation From Bone	<ul style="list-style-type: none"> • Incorrect meat cut. • Overcooking. • Product not fresh. 	<ul style="list-style-type: none"> • Use correct meat cutting procedures. • Check cooking time. • Use fresh product.
B. Bone Color Not Proper	<ul style="list-style-type: none"> • Using frozen product (black bone). • Improper processing of product (black bone). • Product not thoroughly cooked (red bone). 	<ul style="list-style-type: none"> • Use fresh product. • Use proper processing procedure for product. • Check cooking time. • Check cooking temperature.
C. Breading Falls Off	<ul style="list-style-type: none"> • Incorrect breading procedures. • Product partially frozen. 	<ul style="list-style-type: none"> • Use correct breading procedure. • Thoroughly thaw the product, before breading.
D. Product Sticking Together	<ul style="list-style-type: none"> • Product breaded too long prior to cooking. • Improper loading procedure. • Wrong cook button pushed. 	<ul style="list-style-type: none"> • Refer to breading and frying instructions. • Properly load product per loading procedures. • Be sure to select the correct product to be cooked.

Problem	Cause	Correction
POWER SECTION		
<p>With switch in POWER position, the fryer is completely inoperative (NO POWER)</p>	<ul style="list-style-type: none"> • Open circuit. 	<ul style="list-style-type: none"> • Check to see that unit is plugged in. • Check the breaker or fuse at supply box. • Check control panel fuses (electric model only). • Check voltage at wall receptacle. • Check MAIN POWER switch. Replace if defective. • Check cord and plug.
LID/PRESSURE SECTION		
<p>Pressure will not exhaust at end of cooking cycle.</p>	<ul style="list-style-type: none"> • Exhaust line from solenoid valve to condensation tank clogged. • Solenoid valve clogged. 	<ul style="list-style-type: none"> • Turn unit off and allow fryer to cool to release pressure from cookpot; clean all pressure lines, exhaust stacks, and condensation tank. • Check and clean solenoid valve per Maintenance Section on Solenoid Valve.
<p>Operating pressure too high</p>	<ul style="list-style-type: none"> • Dead weight clogged. 	<ul style="list-style-type: none"> • Turn unit off and allow fryer to cool to release pressure from cookpot; remove dead weight and clean.

Problem	Cause	Correction
LID/PRESSURE SECTION (Continued)		
<div data-bbox="203 268 446 451" data-label="Image"> </div> <p data-bbox="152 478 540 982">DO NOT OPERATE UNIT IF HIGH PRESSURE CONDITIONS EXIST, SEVERE INJURIES AND BURNS WILL RESULT. Place the Power/Pump switch in the “OFF” position immediately. Release the pressure by allowing unit to cool. The pressure will then drop. Do not resume use of unit until cause of high pressure has been found and corrected.</p> <p data-bbox="152 1024 378 1094">Pressure does not build</p>	<ul style="list-style-type: none"> <li data-bbox="574 405 971 436">• Exhaust line to stack clogged <li data-bbox="574 1024 959 1094">• Not enough product in fryer or product not fresh. <li data-bbox="574 1171 954 1241">• Metal shipping spacer not removed from dead weight. <li data-bbox="574 1276 906 1308">• Lid open or not latched. <li data-bbox="574 1350 927 1419">• Solenoid valve leaking or not closing. <li data-bbox="574 1539 946 1570">• Dead weight valve leaking. <li data-bbox="574 1644 935 1675">• Pressure not programmed. <li data-bbox="574 1717 841 1749">• Lid gasket leaking. 	<ul style="list-style-type: none"> <li data-bbox="1097 405 1466 436">• Clean exhaust line to stack. <li data-bbox="1097 1024 1466 1136">• Place proper quantity of fresh product within cookpot to generate steam. <li data-bbox="1097 1171 1438 1241">• Remove shipping spacer. See Unpacking Section. <li data-bbox="1097 1276 1360 1308">• Close and latch lid. <li data-bbox="1097 1350 1425 1493">• Check or clean solenoid valve per maintenance section on the solenoid valve. <li data-bbox="1097 1539 1479 1608">• Repair per maintenance section on operating valve. <li data-bbox="1097 1644 1385 1675">• Check programming. <li data-bbox="1097 1717 1474 1829">• Reverse gasket or lid needs adjusted. See Sections 5-10 & 5-13.

Problem	Cause	Correction
LID/PRESSURE SECTION (Continued)		
Lid won't move up or down	<ul style="list-style-type: none"> • Safety relief valve leaking. • Pressure pad broken or crushed. 	<ul style="list-style-type: none"> • Check and replace if necessary per maintenance section on the relief valve. • Replace pressure pads.
	<ul style="list-style-type: none"> • Cable on Counterweight loose or broken Counterweight Cable. • Check operation of counterweight carriage in rear of cooker. 	<ul style="list-style-type: none"> • Put cable on Counterweight per section on • Make proper adjustments.
HEATING OF SHORTENING SECTION		
Shortening will not heat	<ul style="list-style-type: none"> • Blown fuse or tripped circuit breaker at supply box or control panel. • Blown fuse at control panel. • Faulty Cook/Pump switch. • Faulty Cord and Plug. • Faulty contactor. • Faulty Drain Switch. • Faulty PC board. • Faulty high limit control switch. 	<ul style="list-style-type: none"> • Reset breaker or replace fuse. • Check fuse per Maintenance Section on fuses • Check Cook/Pump switch per Maintenance Section on Cook/Pump switch. • Check cord and plug and power at wall receptacle. • Check contactor per Maintenance Section on contactors. • Check drain switch per Maintenance Section on Drain Switches. • Remove and replace control panel. • Check high limit control switch per Maintenance Section on High Limits.

Problem	Cause	Correction
---------	-------	------------

HEATING OF SHORTENING SECTION (Continued)

Heating of shortening too slow (Electric Model)	<ul style="list-style-type: none"> • Low or improper voltage. • Weak or burnt out element(s). • Points in contactor bad. • Wire(s) loose. • Burnt or charred wire connection. 	<ul style="list-style-type: none"> • Use a meter and check the receptacle against data plate. • Check heating element(s) per Maintenance Section on Heating Elements. • Check contactor per Maintenance Section on Contactors. • Tighten. • Replace wire and clean connectors.
Shortening overheating (Electric Model)	<ul style="list-style-type: none"> • Check shortening temperature. • Check contactor for not opening. • Faulty PC Board. • Faulty probe. 	<ul style="list-style-type: none"> • Check temperature setting in the program mode. • Check faulty contactor per Maintenance Section on Contactors. • Remove and replace control panel. • Remove and replace probe.

SHORTENING FOAMING/DRAINING SECTION

Foaming or boiling over of shortening	<ul style="list-style-type: none"> • Water in shortening. • Condensation line stopped up. • Improper or bad shortening. • Improper filtering. 	<ul style="list-style-type: none"> • At end of cooking cycle, drain shortening and clean cookpot. Add fresh shortening. • Remove and clean condensation line. • Use recommended shortening. • Refer to the procedure covering filtering the shortening.
---------------------------------------	---	---

Problem	Cause	Correction
SHORTENING FOAMING/DRAINING SECTION (Continued)		
<p>Shortening will not drain from cookpot</p> <p>Shortening leaking through drain valve.</p>	<ul style="list-style-type: none"> • Cold zone full of cracklings. • Improper rinsing after cleaning the fryer. • Too much stirring. • Drain valve clogged with crumbs. • Drain valve will not open by pulling the knob. • Obstruction in drain. • Faulty drain valve. 	<ul style="list-style-type: none"> • Filter shortening. • Clean and neutralize the cookpot. Rinse with vinegar to remove the alkaline, then rinse with hot water and dry cookpot. • Only stir on initial heat-up. • Open valve - push cleaning brush through drain opening from inside of cookpot. • Replace cotter pins in valve coupling. • Remove obstruction. • Replace drain valve.

CONTROL PANEL SECTION

WARNING

The following guide requires voltage to be present when troubleshooting the control. When the guide refers to connecting pins on the power connection, unplug the power connector from the board and refer to the attached illustration. These are numbered 1 through 9. Using a strand of #16 gauge wire, connect the pins as numbered in the troubleshooting guide. Extreme caution must be taken when connecting these pins to avoid control board damage or electrical shock.

Problem	Correction
With switch in COOK position, the fryer is completely inoperative (no power switch light).	<ul style="list-style-type: none"> • Check to see if unit has voltage. • Check fuses. • Defective power switch.
With switch in COOK position, the fryer is completely inoperative (power switch light on, pump works).	<ul style="list-style-type: none"> • Check voltage on pins 1 and 7 on the power connector, 10 VAC. • If voltage is present, check fuse on control board. • If fuse is defective, replace fuse.
Control operative - all lights on - primary contactor engages - no heat or pressure.	<ul style="list-style-type: none"> • Drain valve open. • Defective drain switch.
Control operative - all lights on - no heat or pressure - primary contactor does NOT engage.	<ul style="list-style-type: none"> • Check 5 amp fuse located on heat shroud - fuse OK. • Check voltage from center of fuse to ground - 208/240 VAC. • Defective transformer.
Control operative - all lights on - has pressure - no heat.	<ul style="list-style-type: none"> • Connect pins 4 and 6 on the power connector. • If contactor engages - replace control board • If contactor does not engage, replace contactor.
Control operative - all lights on - heat on - no pressure - pressure light OFF.	<ul style="list-style-type: none"> • Connect pins 3 and 6 on the power connector. • If solenoid engages - defective control board. • If solenoid does not engage - defective solenoid coil - 208/240 VAC.
Control operative - all lights on - heat on - no pressure - pressure light ON.	<ul style="list-style-type: none"> • Check programming

CONTROL PANEL SECTION (Continued)

Problem	Correction
Error message E-5 display reads HI.	<ul style="list-style-type: none"> • Cool shortening down. • Read display temperature - if display temperature reads HI, unplug power connector from control board. If secondary contactor stays engaged, change contactor - if secondary contactor disengages, change control board. If shortening temperature reads normal - defective thermal sensor - replace.
Error message E-6.	<ul style="list-style-type: none"> • Defective thermal sensor. • Replace thermal sensor.
Error message E-10.	<ul style="list-style-type: none"> • Reset manual high limit thermostat.
Error message E-41.	<ul style="list-style-type: none"> • Depress timer switch. • Control must be completely reprogrammed.

POWER CONNECTOR FROM UNIT TO CONTROL BOARD

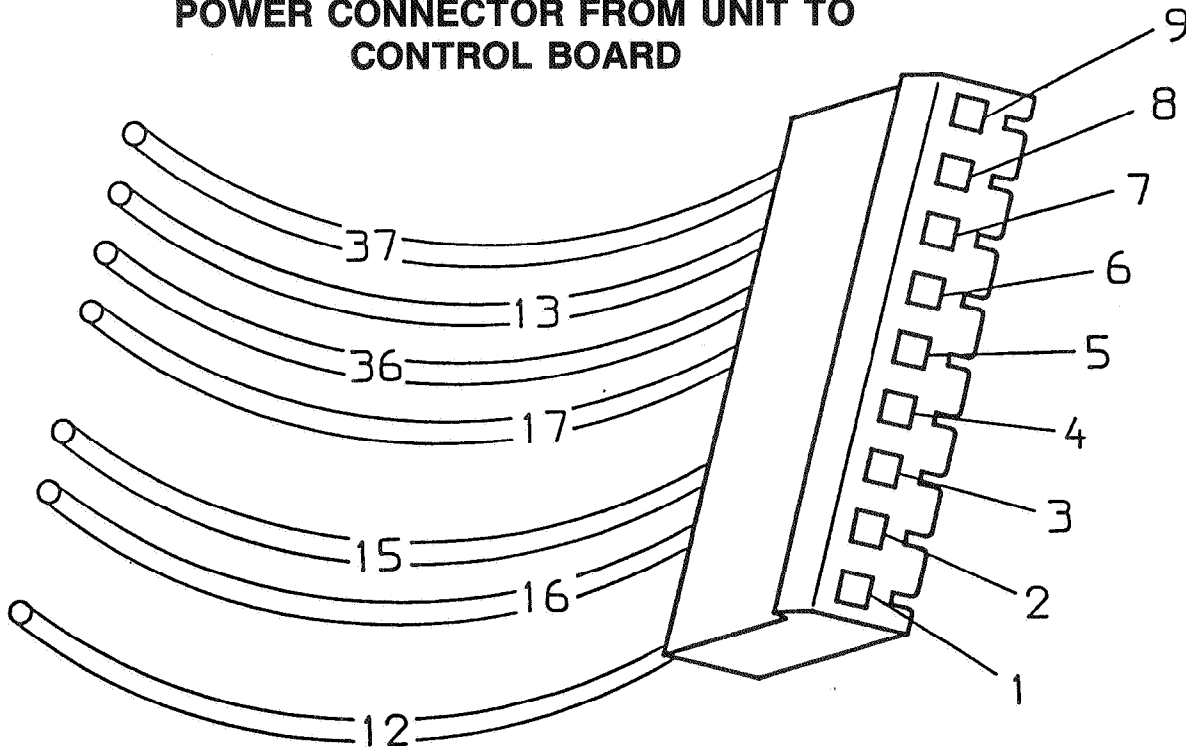

NOTE

If the power connector is making poor contact onto the board, an error message could be read, or it might disable other components. When removing connector, look down into power connector to see if the ramp connectors, inside the power connector, are not flat. If so, they can be removed from the power connector, and bent back into proper position.

SECTION 5. MAINTENANCE

5-1. INTRODUCTION

This section provides procedures for the checkout and replacement of the various parts used within the fryer. Before replacing any parts, refer to the Troubleshooting section. It will aid you in determining the cause of the malfunction.

5-2. ARRANGEMENT

This section is arranged in groupings of the components that work together within the fryer. The general groups are listed below.

- Removing the Control Panel
- Probe
- Electrical Components
- Control Board
- Pressure System

5-3. MAINTENANCE HINTS

1. You may want to use a multimeter to check the electric components.
2. When the manual refers to the circuit being closed, the multimeter should read zero unless otherwise noted.
3. When the manual refers to the circuit being open, the multimeter will read infinity.

5-4. REMOVING COMPLETE CONTROL PANEL

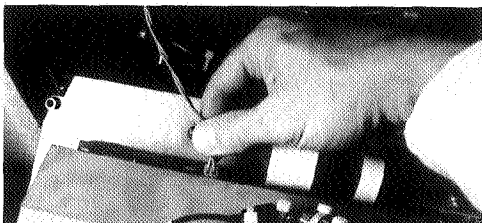
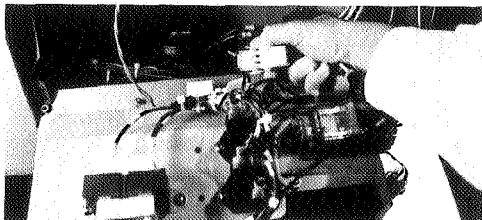

The complete control panel can be easily removed for repair on the panel itself, or for access to the area behind the control panel.

1. Remove electrical power supplied to the fryer.

WARNING

Place the Cook/Pump Switch in the "OFF" position, and unplug the power cord and/or turn the wall circuit breaker off or electrical shock could result.

2. Remove the two screws securing the Control Panel and lift panel up and out.
3. Unplug the 9-pin connector and the probe connection at the Control Board. Then remove complete panel from unit.

5-5. HIGH TEMPERATURE LIMIT CONTROL (Electric Models)

Description

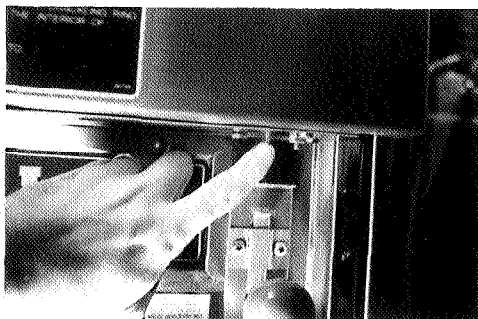

This high temperature control is a manual reset control which senses the temperature of the shortening. If the shortening temperature exceeds 420°F (215°C), this control switch will open and shut off the heat to the cookpot. When the temperature of the shortening drops to a safe operation limit, the control must be manually reset. The reset button is located above the filter knob in the front of the cooker. This will allow heat to be supplied to the cookpot.

Checkout

Before replacing a high temperature limit control, check to see that its circuit is closed.

NOTE

The shortening temperature must be below 380°F (193°C) to accurately perform this check.

1. Remove electrical power supplied to the fryer.

WARNING

Remove electrical power supplied to the fryer by unplugging the unit, or by turning off the wall circuit breaker or electrical shock could result.

2. Remove the control panel.
3. Remove the two electrical wires from the high temperature limit control.
4. Manually reset the control, then check for continuity between the two terminals after resetting the control. If the circuit is open, replace the control, then continue with this procedure. (If the circuit is closed, the high limit is not defective. Reconnect the two electrical wires.)

5-5. HIGH TEMPERATURE LIMIT CONTROL (Electric Models) (Continued)

Replacement

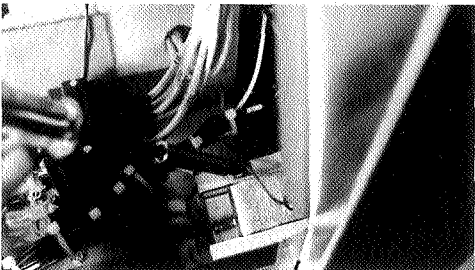
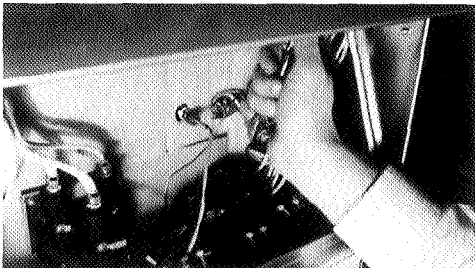
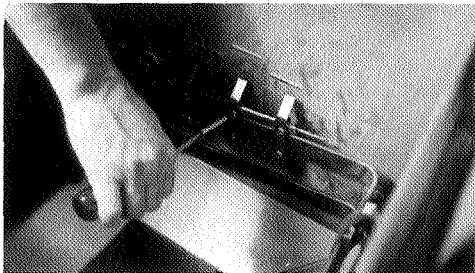
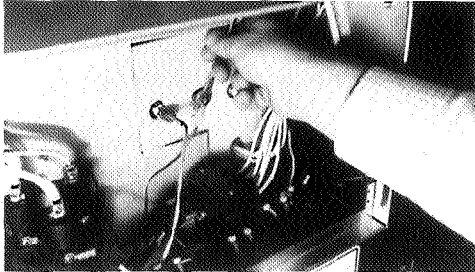

WARNING

Remove electrical power supplied to the fryer by unplugging the unit, or by turning off the wall circuit breaker or electrical shock could result.

1. If the tube is broken or cracked, the control will open, shutting off electrical power. The control cannot be reset.
2. Drain shortening from the cookpot and discard. A substance in the tube could contaminate the shortening.
3. Remove control panel.
4. Loosen small inside screw nut on capillary tube.
5. Remove capillary bulb from bulb holder inside the cookpot.
6. Straighten the capillary tube.
7. Remove larger outside nut that threads into pot wall.
8. Remove the two nuts securing the high limit bracket at the front of the fryer, and remove bracket.
9. Loosen the three screws that secure high limit to the high limit bracket.
10. Remove defective control from control panel area.
11. Insert new control and replace screws.
12. Uncoil capillary line, starting at capillary tube, and insert through cookpot wall.

WARNING

To avoid electrical shock or other injury, the capillary line must run under and away from all electrical power wires and terminals. The tube must NEVER be in such a position where it could accidentally touch the electrical power terminals.

13. Carefully bend the capillary bulb holder on heating elements.

5-5. HIGH TEMPERATURE LIMIT CONTROL (Electric Models) (Continued)

14. Slip capillary bulb into bulb holder located on heating elements. Pull excess capillary line from pot and tighten nut into cookpot wall.

CAUTION

Be sure capillary bulb of high limit is positioned as not to interfere with basket or when cleaning the cookpot wall, or damage to capillary tube could result.

- 15. With excess capillary line pulled out, tighten smaller nut.
- 16. Replace front panel.
- 17. Refill with shortening.

5-6. FUSE HOLDERS

There are two fuse holders on each model of the electric fryers.

WARNING

Remove electrical power supplied to the fryer by unplugging the unit, or turning off the wall circuit breaker or electrical shock could result.

Checking Procedure for Fuses

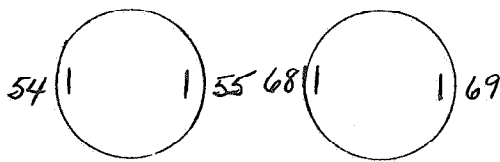

CONTROL PANEL FUSES 3 Phase Check from #54 to #55 and #68 to #69 on fuse assembly, or the fuse can be removed to check for a closed circuit. If not, replace the fuse (HP# EF02-007).

5-7. COOK/PUMP SWITCH

The Cook/Pump Switch is a three way rocker switch with a center "OFF" position. With the switch in the "COOK" position the fryer will operate. With the switch in the "PUMP" position the filter pump will operate, but the heating unit will not.

WARNING

Remove electrical power supplied to the fryer by unplugging the unit, or turning off the wall circuit breaker or electrical shock could result.

5-7. COOK/PUMP SWITCH
(Continued)

Checkout

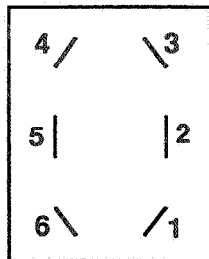

Replacement

1. Remove Control Panel.
2. "OFF" Position - should be open circuit anywhere on the switch.
3. "COOK" Position - Check from:
#5 to #6 closed circuit
#1 to #2 closed circuit
4. "PUMP" Position - Check from:
#4 to #5 closed circuit
#3 to #2 closed circuit

NOTE

Check across the jumpers on the wires of the Cook/Pump Switch. These jumpers have resistors and capacitors which may be faulty.

1. With control panel removed and wires off of the switch, push in on tabs on the switch to remove from the panel.
2. Replace with new switch, and reconnect wires to switch following the wiring diagram.
3. Replace the control panel.

5-8. CONTACTORS

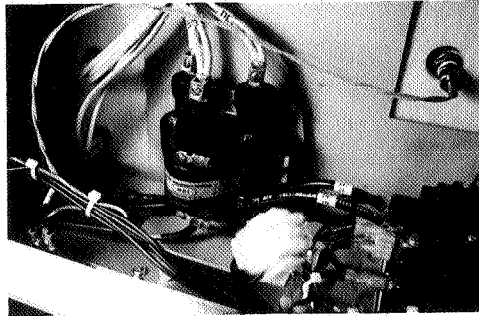
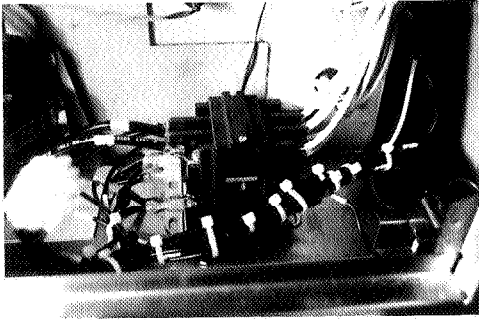

Checkout

The electric fryer requires two switching contactors: a primary contactor and a heat contactor. The primary contactor energizes (contacts close) any time the Cook/Pump Switch is in the "COOK" position and the temperature of the pot is below 420°F (215°C). The high limit will cut the power at the primary contactor if temperatures in the cookpot exceed 420°F (215°C). The primary contactor supplies power to one side of the heat contactors.

The heat contactor (mercury contactor) is controlled by the computer controller. When the controller calls for heat, the heat contactor applies power to one side of the heating elements. When the heat contactor and the primary contactor are energized (contacts closed), the electric heating elements heat the shortening.

1. Remove electrical power supplied to the fryer.

WARNING

Remove electrical power supplied to the fryer by unplugging the unit, or turning off the wall circuit breaker or electrical shock could result.

2. Remove the control panel.
3. Perform a check on both contactors as follows:

Test Point	Results
L3 - L3	Open Circuit
L2 - L2	Open Circuit
L1 - L1	Open Circuit

4. Check across the coil terminals:
 Standard Contactor - 415 ohms
 Mercury Contactor - 1500 ohms

5-8. CONTACTORS (Continued)

Replacement

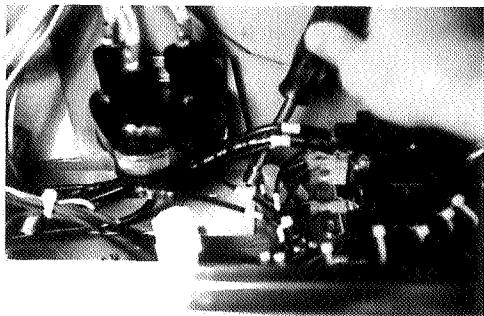
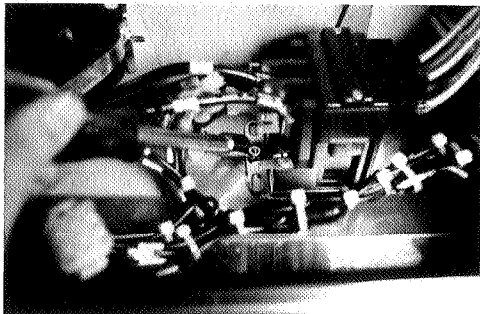

WARNING

The following checks are performed with the wall circuit breaker on, and the Cook/Pump Switch in the "COOK" position. Extreme caution should be taken. Make connections before applying power, take reading, and remove power by unplugging the power cord, or by turning off the wall circuit breaker, before removing meter leads or electrical shock could result.

5. With power re-applied and in a heat-up mode, check the power going to both contactor coils. This is to be sure power is going to the contactors.

If no voltage is found going into the coils, check wiring, high-limit, and drain switch for the primary contactor. (See Maintenance Section). For the heat contactor, check wiring and connection at the P.C. Board.

If either contactor is defective it must be replaced as follows:

WARNING

Remove electrical power supplied to the fryer by unplugging power cord or turning off the wall circuit breaker, or electrical shock could result.

1. Remove only those wires directly connected to the contactor being replaced. Label the wires.
2. Remove the two mounting nuts on the base plate and remove standard contactor (primary), proceed to step 5, if this is the contactor to be replaced.
3. Remove the two mounting nuts securing the mercury contactor bracket to the base plate and remove bracket.
4. Remove the two screws securing the mercury contactor to the bracket and remove contactor.
5. Install new contactor in reverse order of previous steps.
6. Install control panel.
7. Reconnect power to fryer and test the fryer for proper operation.

5-9. HEATING ELEMENTS

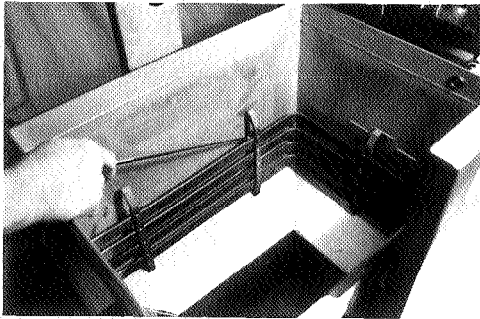

Each electric fryer uses two heating elements.

NOTE

Heating elements are available for 208 or 220/240, 380 and 415 voltage. Check the data plate on the right side panel of unit to determine the correct voltage.

If the shortening's temperature recovery is very slow, or at a slower rate than required, this may indicate defective heating element(s). A multimeter will quickly indicate if the elements are shorted or open.

1. Remove electrical power supplied to the fryer.

WARNING

Remove electrical power supplied to the fryer by unplugging the unit, or turning off the wall circuit breaker or electrical shock could result.

2. Remove the Control Panel.

WARNING

The following checks are performed with the wall circuit breaker closed and the Cook/Pump switch in the "COOK" position. Extreme caution should be taken. Make connections before applying power, take reading, and remove power by unplugging the power cord, or by turning off the wall circuit breaker, before removing meter leads, or electrical shock could result.

3. Perform an amp check on one heating element at a time with the wires connected to the contactors. The two heaters actually have three small heating elements on the inside of the outer plate. It is important to check between the correct wires to obtain an accurate amp reading. The wires are labelled for your convenience.

Wires	Power	Voltage	Amperage
L1 - L3	8500 W	208 V	48
L3 - L2	8500 W	208 V	48
L2 - L1	8500 W	208 V	48
L1 - L2	8500 W	240 V	40
L3 - L2	8500 W	240 V	40
L2 - L1	8500 W	240 V	40

5-9. HEATING ELEMENT (Continued) Replacement

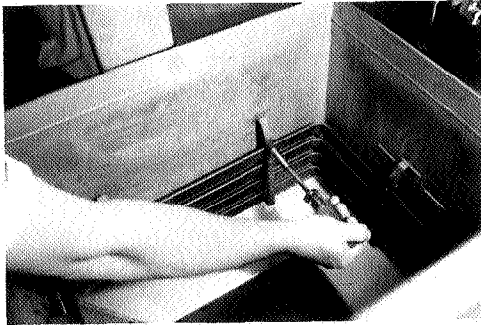

1. Drain the shortening.
2. Remove the high limit bulb holder from the heating element.
3. Remove the Control Panel.
4. Disconnect the heating element wires from the contactors.
5. Loosen the screws on the element spreaders.
6. Slide the element spreaders to the back of the heating elements.
7. Pull wires through insulation and bend insulation down, out of the way.
8. Remove the brass nuts and washers which secure the ends of the elements through the cookpot.
9. Remove the heating elements from the cookpot as a group by lifting the far end and sliding them up and out toward the rear of the cookpot.

CAUTION

Always install new rubber "O" rings when installing heater elements.

10. Install new heating elements with new rubber "O" rings mounted in the center of the stacked elements.
11. Replace the heating elements, terminal ends first at approximately 45° angle, slipping the terminal ends through the front wall of the cookpot.
12. Replace the brass nuts and washers on the heating element terminals.
13. Move the element spreaders from the back of the elements into a position which will spread each element apart evenly on all four sides, and tighten.
14. Replace the high limit bulb holder on the top element, and position the bulb above the top element and tighten screws which hold bulb in place.
15. Reconnect the wires to the appropriate terminals.
16. Replace the front control panel.
17. Connect the power cord to the wall receptacle or turn wall circuit breaker on.

5-9. HEATING ELEMENT (Continued)

CAUTION

Heating elements should never be energized without shortening in the cookpot, or damage to heating elements could result.

18. Replace shortening in cookpot.

5-10. DRAIN SWITCH

All fryers are equipped with a drain valve micro-switch that prevents heat from coming on when the drain valve is open. With the drain valve open, the switch prevents power from being applied to the coil of the primary and heat contactors, and the solenoid coil.

WARNING

Remove electrical power supplied to the fryer by unplugging the unit, or turning off the wall circuit breaker or electrical shock could result.

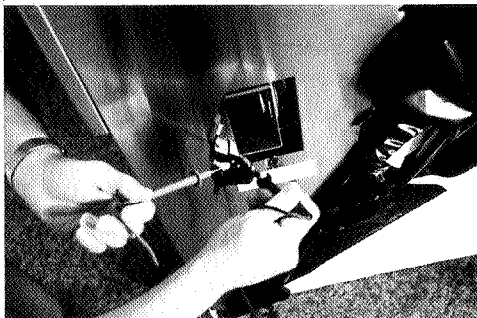

1. The following check should be made to determine if the Drain Switch is defective.
 - a. Remove the access panel on the right side of the unit.
 - b. Remove and label the wires from the Drain Switch.
 - c. Check for continuity across the two outside terminals on the Drain Switch. If circuit is open, the Drain Switch is bad. The circuit should only be opened by pressing on the actuator of the Drain Switch.
2. To replace the Drain Switch, use a 5/8" wrench and remove the nut securing the switch to the bracket.
3. Position actuator and attach the Drain Switch to the bracket with the nut.
4. Connect wires to Drain Switch.
5. Test to see if drain valve extension rod actuates the switch. NOTE - Listen for CLICK of switch while pulling drain valve extension rod.

5-11. TEMPERATURE PROBE REPLACEMENT

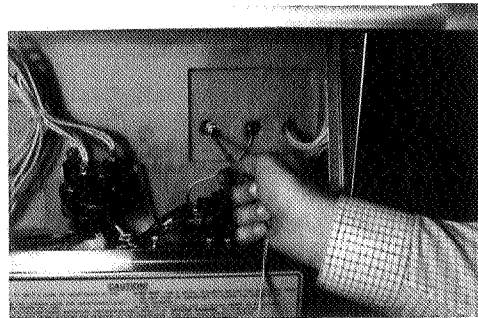
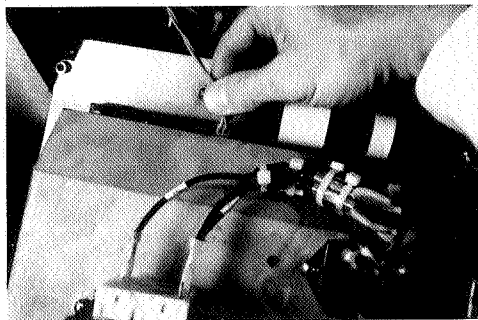

The Temperature Probe relays the actual shortening temperature to the control. If it becomes disabled, E06 will show in the display. Also, if the temperature is out of calibration more than 10°F or C°, the probe should be replaced as follows:

1. Remove electrical power supplied to the fryer.

WARNING

Place the Power Switch to the "OFF" position, and unplug the power cord or turn the wall circuit breaker off or electrical shock could result.

2. Drain the shortening from the cookpot.
3. Remove the Control Panel.
4. Remove probe connections from PC board.
5. Using a 1/2" wrench, remove the nut on the compression fitting.
6. Remove the probe from the cookpot.
7. Place the nut and new ferrule on the new probe and insert the probe into the compression fitting until it extends 1/2 inch (1.3 cm) into the cookpot. (See Figure 5-1.)
8. Tighten, hand tight, and then half turn with wrench.

CAUTION

Excess force will damage probe.

9. Connect new probe to PC board and replace control panel.
10. Replace shortening.
11. Turn power "ON" and check out fryer.

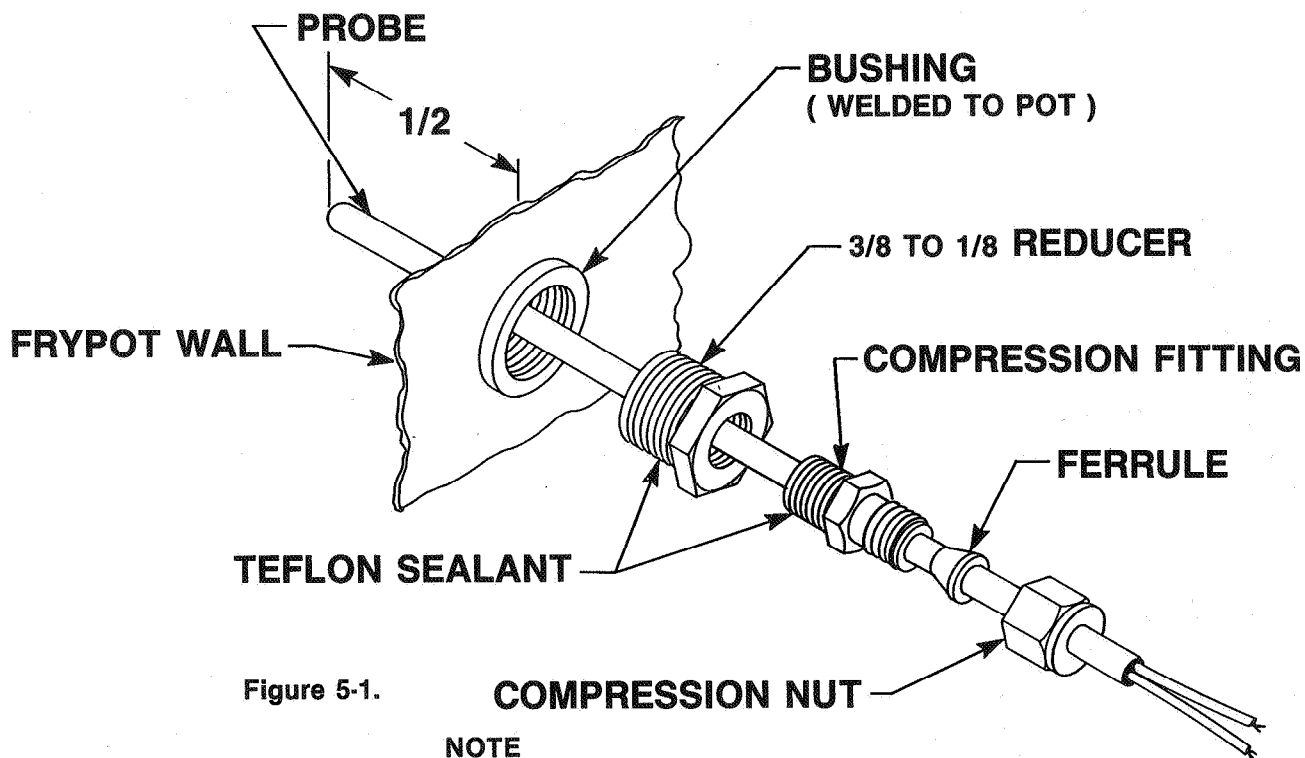

Figure 5-1.

COMPRESSION NUT

NOTE

Probe is to be mounted 1/2 inch from the pot bushing, NOT the pot wall.

5-12. CONTROL BOARD REPLACEMENT

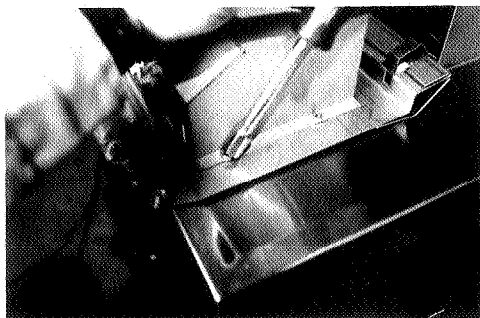
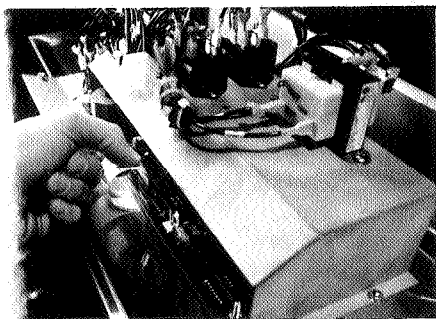

Should the control panel become inoperative, follow these instructions for replacing the control board.

1. Remove electrical power supplied to the fryer.

WARNING

Place the Cook/Pump Switch in the "OFF" position, and unplug the power cord and/or turn off the wall circuit breaker, or electrical shock could result.

2. Remove the complete control panel from unit. (See Section 5-4.)
3. Unplug Keyswitch and ribbon connectors from board.
4. Using 5/16" socket remove the four nuts securing control panel cover and unplug straight nine-pin connector from board. Then lay the cover off to one side.

**5-12. CONTROL BOARD
REPLACEMENT
(Continued)**

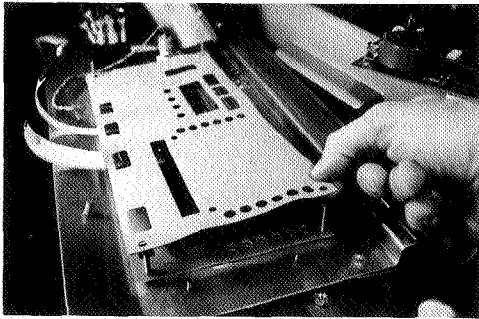
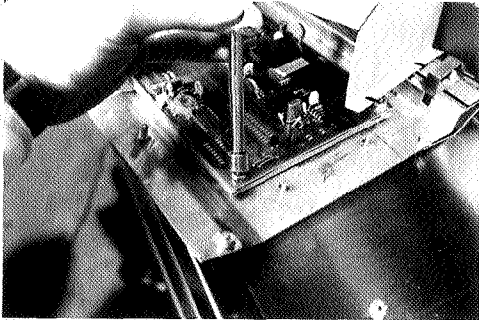

5. Using 5/16" socket remove the four nuts securing the control board and remove board.

NOTE

The cardboard insulator will probably come up along with the control board. When installing a new control board be sure to get the spacers installed between the insulator and the board.

6. Install new control board in reverse manner.

**5-13. SWITCHBOARD
REPLACEMENT**

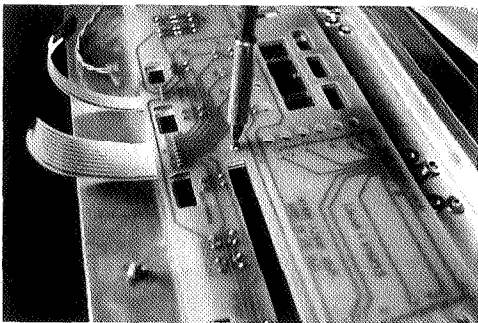

1. Follow steps 1 thru 5 from instructions above.
2. Unscrew the small screw from the middle of the switch board and remove switch board from studs.
3. Replace switch board in reverse manner.

NOTE

During disassembly some wires may have inadvertently come off terminals. Make sure all loose wires are reconnected after assembly is complete.

5-14. HEAT RELAY

Checkout

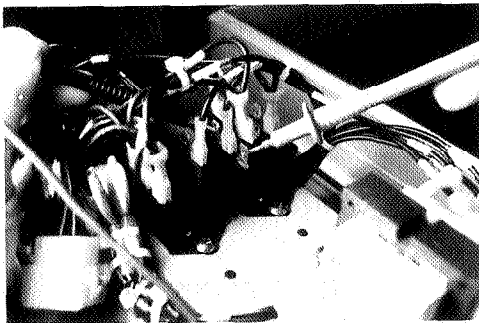

The heat relay transfers the voltage to the heat contactor coil, energizing this coil, then the elements begin to heat. The elements not heating could be caused by a faulty relay.

1. Remove electrical power supplied to the unit.

WARNING

Remove the electrical power supplied to the fryer by unplugging the unit, or turning off the wall circuit breaker, or electrical shock could result.

2. Remove the Phillips head screws from the control panel. Then lift the complete control panel up and out of position, leaving the connectors attached.

WARNING

The following checks are performed with the wall circuit breaker on, and the COOK/PUMP Switch in the "COOK" position. Extreme caution should be taken. Make connections before applying power, take reading, and remove power by unplugging the power cord, or by turning off the wall circuit breaker before removing meter leads, or electrical shock could result.

3. Take a voltage check across the N.O. terminal which has wires 5A and 22A attached, and terminal COM which has wires 6A and 27A attached. If zero voltage is detected, the relay is good. If 208 or 240 volts is found, continue on to the next step.
4. Remove power to unit, and then move wire numbers 5A and 22A to the NC terminal, on the opposite side of the relay.
5. Turn power back on and turn the COOK/PUMP switch to the "COOK" position.
6. If unit now heats up the relay needs to be replaced. If the unit does not heat up, and a voltage check from the NC terminal to the COM terminal shows 0 volts, the relay is good and a problem lies somewhere else.

5-14. HEAT RELAY (Continued)

Replacement

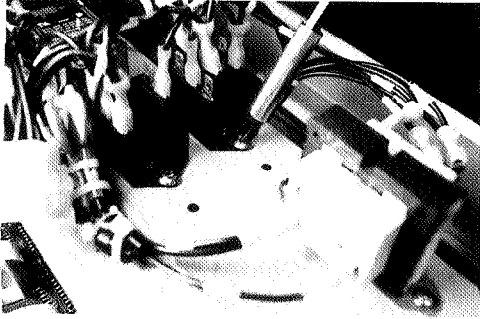

1. With the control panel dropped down and the electrical power disconnected, unplug the nine-pin connector and probe from board. Then remove complete panel from unit.
2. Unplug the wires from the relay, labeling the wires to ensure correct placement on new relay.
3. Unscrew the two Phillips head screws securing the relay, and remove relay.
4. Replace new relay in reverse order.

5-15. PRESSURE RELAY

The pressure relay transfers the voltage onto the solenoid, which closes and the unit can then build pressure. If the fryer doesn't pressurize during a cook cycle, the pressure relay may be faulty.

Checkout

1. Remove electrical power supplied to the unit.

WARNING

Remove electrical power supplied to the fryer by unplugging the unit, or turning off the wall circuit breaker, or electrical shock could result.

2. Remove the two Phillips head screws from the control panel. Then lift complete panel up and out of position, leaving the connectors attached.

WARNING

The following checks are performed with the wall circuit breaker on, and the COOK/PUMP switch in the "COOK" position. Extreme caution should be taken. Make connections before applying power, take reading and remove power by unplugging the power cord, or by turning off the wall circuit breaker before removing meter leads, or electrical shock could result.

5-15. PRESSURE RELAY (Continued)

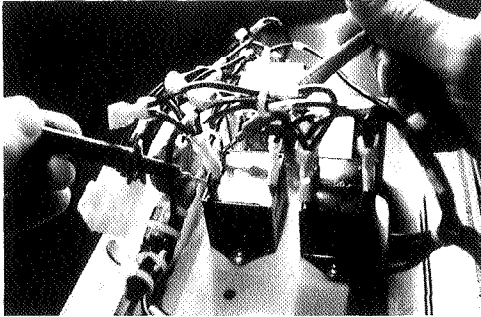

Replacement

3. Take a voltage check across the NO terminal which has wires 8A and 21A attached, and terminal COM which has wires 27A and 20A attached. If zero voltage is detected, the relay is good. If 208 or 240 volts is found, continue on to the next step.
4. Remove power to unit and then move wires 8A and 21A to the NC terminal on the opposite side of the relay.
5. Turn power back on and turn the COOK/PUMP switch to the "COOK" position.
6. Press the timer switch. If the solenoid does not engage and a voltage check from the NC terminal to the COM terminal shows 0 volts, the relay is good, and a problem lies somewhere else.

1. With the control panel dropped down, and electrical power disconnected, disconnect the nine-pin connector and probe from board. Then remove complete panel from unit.
2. Unplug the wires from the relay, labeling the wires to ensure correct placement on new relay.
3. Unscrew the two Phillips head screws securing the relay, and remove relay.
4. Replace new relay in reverse order.

5-16. "E10" RELAY

Checkout

When the high limit or drain microswitch are kicked off, this relay sends 12 volts to the board and "E10" is displayed.

1. Remove electrical power supplied to the unit.

WARNING

Remove electrical power supplied to the fryer by unplugging the unit, or turning off the wall circuit breaker, or electrical shock could result.

2. Remove the two Phillips head screws from the control panel. Then lift complete panel up and out of position, leaving the connectors attached.

5-16. "E10" RELAY (Continued)

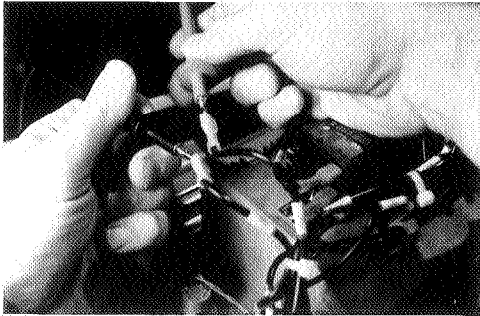

Replacement

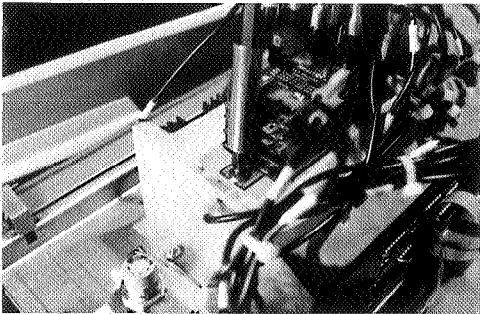

5-17. KEYSWITCH

Replacement

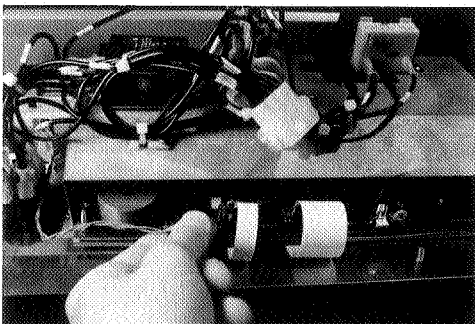

WARNING

The following checks are performed with the wall circuit breaker on, and the COOK/PUMP switch in the "COOK" position. Extreme caution should be taken. Make connections before applying power, take reading, and remove power by unplugging the power cord or by turning off the wall circuit breaker before removing meter leads, or electrical shock could result.

3. Pull wires 9A and 26A from relay and check voltage across the wires. If 208 and 240 volts is indicated, the relay should be replaced. If 0 volts is indicated, the high limit or drain microswitch are kicked, or bad.

1. With the control panel dropped down and the electrical supply disconnected, unplug the nine-pin connector and probe from the board. Then remove the complete panel assembly.
2. Unscrew the two Phillips head screws and remove relay and install new relay.

The keyswitch allows the programming mode to be accessed once the key is inserted.

1. Remove the electrical power supplied to the unit.

WARNING

Remove electrical power supplied to the unit by unplugging the unit or turning off the wall circuit breaker, or electrical shock could result.

2. Remove the two Phillips head screws from the control panel. Then lift complete panel up and out of position, and unplug nine-pin connector and probe from board. Then remove complete panel assembly from unit.
3. Unplug switch from the board.

**5-17. KEYSWITCH
(Continued)**

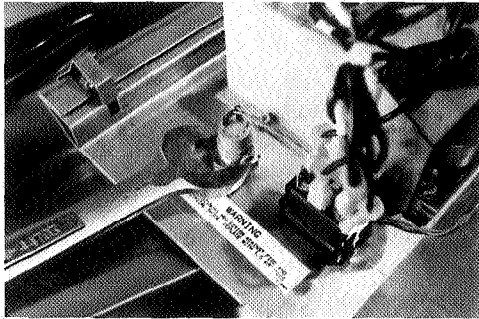

4. Using 7/8" wrench, unscrew nut securing the switch to the panel, and remove switch.
5. Install new switch in reverse order.

5-18. TRANSFORMER

The control panel transformer reduces the voltage from either 208 or 240 volts to 12 volts.

Checkout

1. Remove electrical power supplied to the unit.

WARNING

Remove electrical power supplied to the unit by unplugging the unit or turning off the wall circuit breaker, or electrical shock could result.

2. Remove the two Phillips head screws from the control panel. Then lift complete panel up and out of position.
3. Check voltage across the terminals marked 240 volt or 208 volt. If the correct voltage is indicated, check for 12 volts across the terminals marked LOAD. If 12 volts (+/- 1.2 volts) is indicated, then the transformer is good. If 0 volts is indicated, or if too much voltage is indicated, the transformer needs replaced.

Replacement

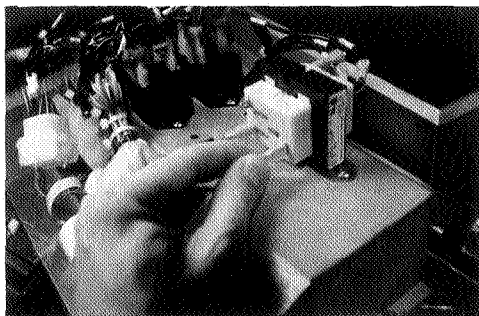

1. With the control panel dropped down, and the electrical power disconnected, disconnect the nine-pin connector and probe from board. Then remove complete panel from unit.
2. Unplug and label wires from transformer.
3. Unscrew the two Phillips head screws and remove transformer from back of panel.
4. Replace transformer with new transformer.

PRESSURE REGULATION

The Henny Penny Fryer uses pressure as one of the components of the cooking process. Once the lid is sealed to the cookpot, and the solenoid valve closes, a deadweight valve maintains the correct pressure in the cookpot.

The lid has minimal and limited maintenance and repair procedures, which are addressed in the following sections.

The following is a routine maintenance schedule for the Lid:

Every 90 days

- Clean and reverse lid gasket

Yearly Cleaning and Inspection

- Remove and clean Safety Relief Valve
- Check Lid Gasket for splitting and tears - replace if necessary
- Check Pressure Pads for wear - rotate if necessary
- Check Cam Slide Guides - replace if worn or broken
- Check Lid Rollers - replace if cracked or damaged.

5-19. REVERSING THE LID

The gray rubber gasket surrounding the inside of the lid is designed to be reversed. HENNY PENNY RECOMMENDS THAT THIS BE DONE EVERY 90 DAYS.

Because of heat expansion and the pressure used for the cooking process, the gasket is constantly under extreme stress. Reversing the lid gasket every 90 days helps to assure that the fryer will not lose pressure through leakage.



1. Put the lid in the upright position, as previously described in section 3-2.
2. Using a thin blade screwdriver pry out the gasket at the corners. Remove the gasket.

WARNING

Be careful that the lid doesn't fall down while it is in the upright position, or serious injury could result.

3. Clean gasket and the gasket seat with soap and hot water.
4. Rotate gasket with the opposite side facing out.

5-19. REVERSING THE LID GASKET (Continued)

NOTE

Begin the installation by installing the four corners of the lid gasket, and smoothing the gasket into place from the corners.

5-20. LID COUNTERWEIGHT

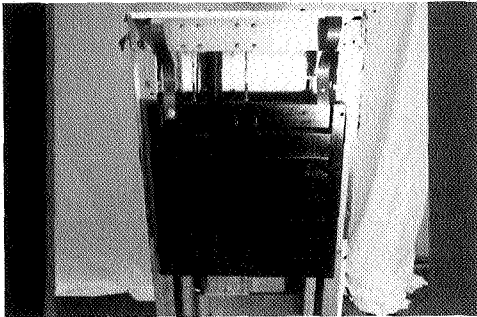

The Lid Counterweight in the back of the fryer balances the weight of the lid system to allow easier opening and closing of the lid. The weight has two cables attached to it, and weighs about 150 lbs. (67.5 Kg). One cable is centered on the weight and is the cable being used. The other cable is a safety cable and is off center. In case the main cable becomes loose or broken, the safety cable catches the weight and puts the weight into a bind, not allowing the lid to be opened or closed.

Replacement/Repair

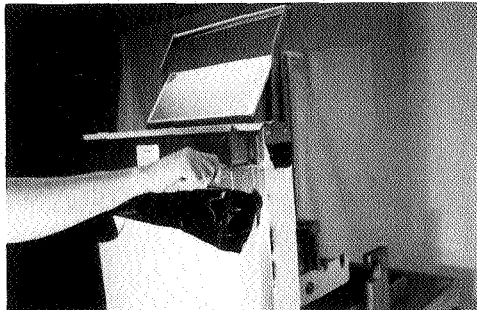

1. Using a 3/8" socket, remove the back shroud of the fryer.

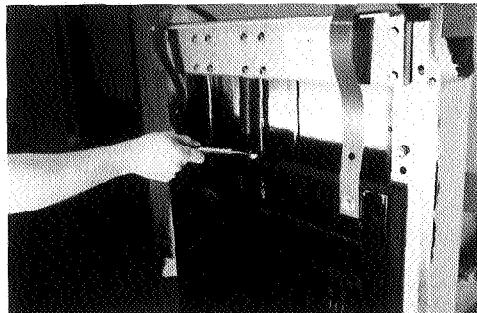

2. With one person holding the weight level, another person locks the lid down.

3. Unthread the broken cable from the weight and the bracket attached to the fryer, and remove broken cable.



4. Thread a 5/16" nut on each end of the new cable.

5. Screw the new cable into the weight, using a wrench, until it is tight.

6. Using a 1/2" wrench, tighten the nut (already threaded on the cable) against the weight securing the cable into the weight.

5-20. LID COUNTERWEIGHT (Continued)



7. Pull cable over pulley and down behind the weight.
8. Thread the other end of the cable through a 5/16" nut on the underside of the bracket.
9. Tighten the cable up by screwing the cable through the nut, until the weight becomes level.

NOTE

The safety cable should now have some slack in it, with the weight level. (See photo at left).

10. Tighten the nut against the bracket, securing the cable.
11. Replace the back shroud. Repair is now complete.

5-21. PRESSURE PADS

Removal

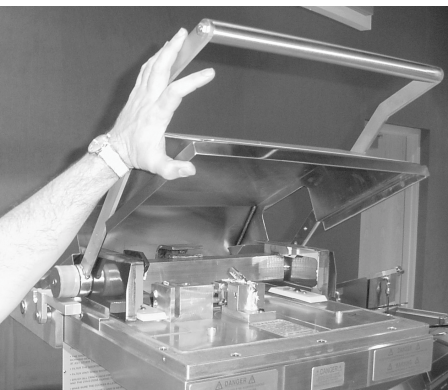

The Pressure Pads are plastic strips that the lid cam presses against to seal the lid. They are located under the lid cover and under the lid cam.

1. Raise the lid.
2. Remove the four screws securing the lid cover and remove cover.
3. Push the lid cam back, off of the pressure pads.
4. Using a 5/32" hex drive, remove the bolt securing the pressure pad and remove broken pad.
5. Install new pad in reverse order.

NOTE

If one side of the pressure pad is worn or broken, the pad can be turned 180° and the opposite end of the pressure pad used. Remove the bolt and turn the pad end for end.

5-22. LID ADJUSTMENT

If steam leaks out from around the lid gasket, the pressure pads could be worn or broken. If the pressure pad is worn, but not broken, it can be reversed 180 degrees, and the other end of the pad used. See Section 5-12.

WARNING

Other problems could cause the steam to leak, such as a cracked or worn gasket, or gasket not installed properly. Be certain leaking is not caused by too much pressure before making any lid adjustments. Fryer should be operating at 12 psi. Refer to Operating Control Valve section. All these areas should be checked, or serious burns could result.

5-24. ADJUSTING THE MAGNET PLATE

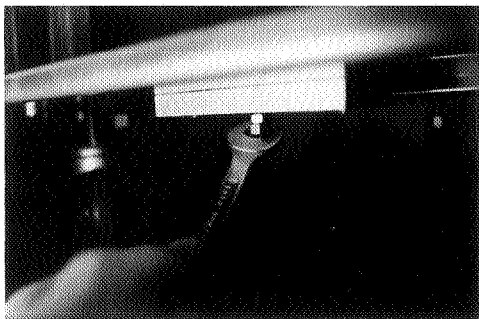
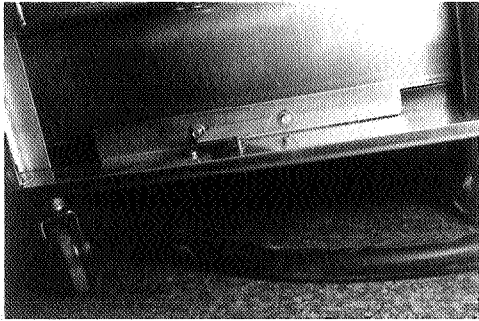

With the carrier and racks installed on the lid, the lid should stay down, in contact with the pot rim, when the lid is lowered. The user will then be able to lock the lid in place. If the lid has a tendency to rise up before getting the lid locked down, the magnet plate probably needs adjusting. Follow these steps:

1. Remove the six nuts securing the back shroud and remove back shroud.
2. Loosen the bottom nut under the plate and unscrew both nuts a couple turns, then lower the lid again to see if the lid stays down. If not, repeat procedure.
3. Tighten lower nut up against the other nut and install back shroud - adjustment is now complete.

5-25. SOLENOID VALVE

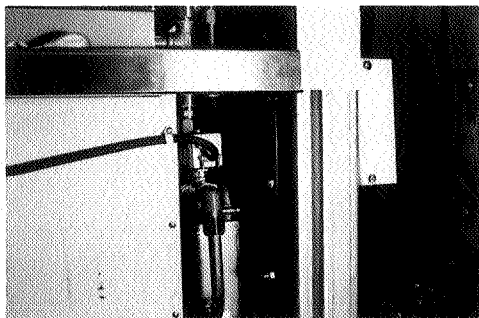

This is an electromechanical device that causes pressure to be held in the cookpot. The solenoid valve closes at the beginning of the cook cycle and opens automatically at the end of the cook cycle. If this valve should become dirty, or the Teflon seat is nicked, pressure will not build up. The electric fryer uses a 208/240 volt, 60 hertz coil (50 hertz internationally).

WARNING

Before starting repair procedures, move the Cook/Pump switch to the "OFF" position. Disconnect main circuit breaker at the circuit breaker box and/or unplug service cord from the wall receptacle or electrical shock could result.

Coil Check Procedure

Remove the solenoid wires from the wire nuts which are found behind the control panel. Check across wires.

	Results
208/240 Volt, 60 Hz	150 Ohms
208/240 Volt, 50 Hz	230 Ohms

5-25. SOLENOID VALVE (Continued) Replacement

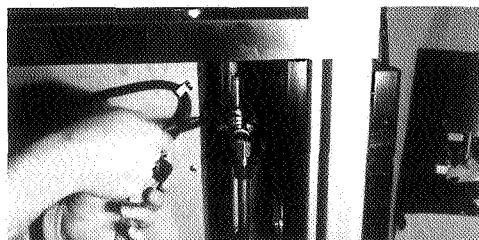
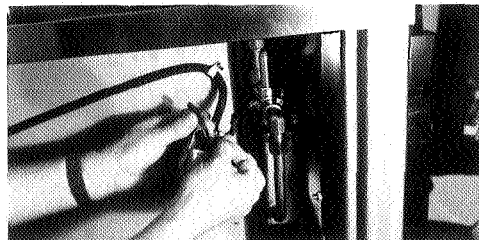
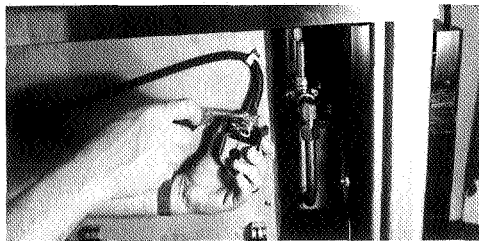
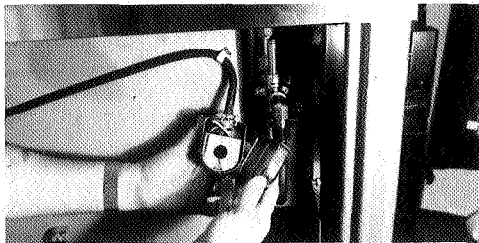
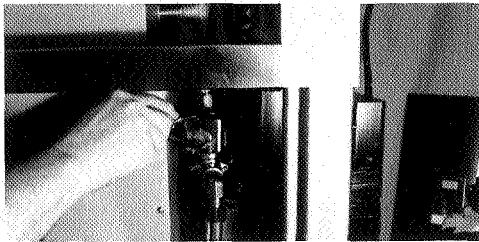
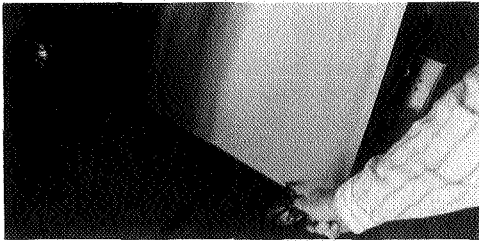

NOTE

Prior to servicing the solenoid valve, it is necessary to remove the side panel on the right side of the unit. Remove the two Phillips head screws and panel will drop down.

1. Remove the "tru-arc" retaining clip on top of the coil housing.
2. Remove the cover.
3. If only the coil is to be replaced, disconnect the two coil wires at the wire nuts in the coil housing. Remove the coil, insert new coil, and connect the wires at the wire nuts. Assemble in reverse order of disassembly.

NOTE

The wires may be connected in any order.

4. Loosen the screws on the strain relief and pull the wires through the relief.
5. If the core-disc assembly is sticking due to buildup of shortening, breading, and food particles, proceed with the following steps.
 - a. Unscrew the solenoid bonnet assembly from the solenoid valve body.
 - b. Remove the solenoid bonnet assembly and bonnet gasket.
 - c. Remove the core-disc assembly, core spring retainer, and the core spring.
 - d. Wash all these parts in hot water.

NOTE

If Teflon seals need to be replaced, proceed to Step 6; otherwise, assemble in reverse order of disassembly. Assemble valve core and blade with smooth side and rounded edge of blade toward the disc spring guide.

**5-25. SOLENOID VALVE
(Continued)**

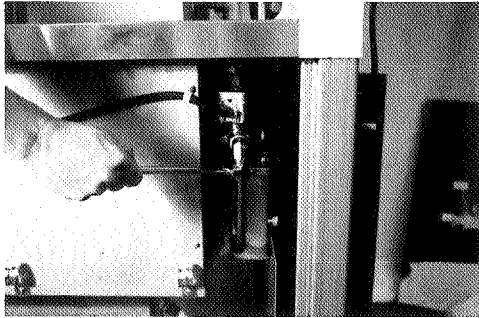

6. A repair kit (Henny Penny part number 17120) is available if any of the seals must be replaced. If any one seal is defective, they all should be replaced.

NOTE

Solenoid body must be removed from the fryer for replacement of seals.

7. With the bonnet assembly and core-disc assembly removed, disconnect the two nut fittings. One connects the solenoid valve to the dead weight system, the other is attached to the condensation tank.
8. Remove the elbows from the solenoid valve.
9. Remove the two adapter screws which attach the pipe adapter to the solenoid valve body.
10. Remove the disc spring, guide, and Teflon seat.
11. Clean the valve body.
12. Wet "O" ring around seat with water and insert "O" ring assembly (flat side first) in valve through "IN" side of body. Use an eraser end of a pencil and press in the Teflon seal until it snaps into place. **BE CAREFUL NOT TO MAR OR NICK THE SEAT.**

NOTE

The smallest nick can cause a pressure leak. Replace all "O" ring seals that are in the parts kit and reassemble valve.

13. If the complete valve is to be replaced, follow steps 1, 2, 3, 4, 5, 7, and 8 in this section. Reassemble in reverse order.

**5-26. OPERATING CONTROL
VALVE**



Do not attempt to remove the valve cap while the fryer is operating, or severe burns or other injuries could result.

5-26. OPERATING CONTROL VALVE

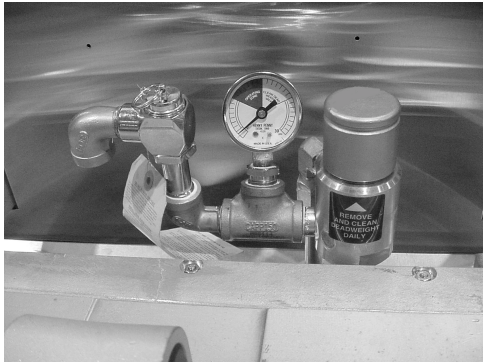

DO NOT ATTEMPT TO REMOVE THE VALVE CAP WHILE THE FRYER IS OPERATING, or severe burns or other injuries could result.

The operating valves are located at the back of the unit. The valve left of the pressure gauge is a 14-½ lb. safety relief valve, and to the right of the pressure gauge, the operating valve.

Valves are working properly, when “OPERATING ZONE” indicates on the gauge by the pointer. The gauge pointer should not normally exceed the operating zone. If the pressure builds to 14 ½ lbs., the safety relief valve opens and releases pressure from the frypot.



DO NOT MANUALLY ACTIVATE THE SAFETY RELIEF VALVE. Hot steam will be released from the valve when the ring is pulled. Keep away from safety valve exhaust, or severe burns could result.

Cleaning Steps

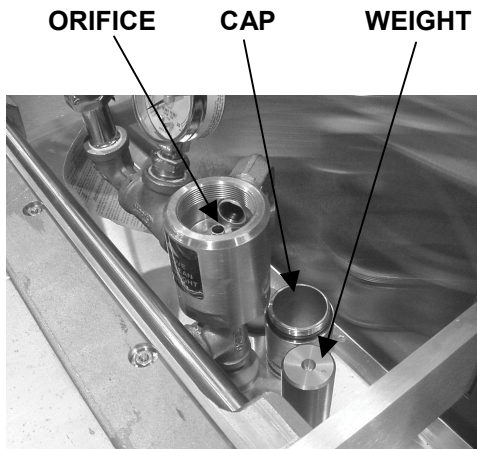

1. AT THE END OF EACH DAY’S USAGE OF THE FRYER, THE OPERATING VALVE MUST BE CLEANED. The fryer must be OFF and the pressure released. Open the lid and then remove the dead weight valve cap and dead weight.



Failure to clean the operating valve daily could result in the fryer building too much pressure. Severe injuries and burns could result.

2. Wipe both the cap and weight with a soft cloth. Make certain to thoroughly clean inside cap, the weight seat, and around valve orifice. (See Section 3-12).
3. Dry the parts and replace immediately to prevent damage or loss.

5-27. REMOVAL & CLEANING OF SAFETY RELIEF VALVE

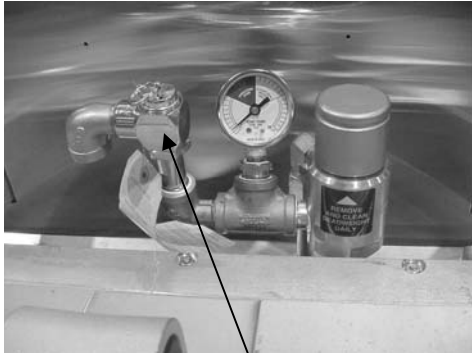

SAFETY RELIEF VALVE

The safety relief valve should be cleaned once a year.



Do not attempt to remove valve while fryer is operating, or severe burns or other injuries could result.

1. Remove the pressure gauge. See section 5-28.
2. Use a wrench to loosen the valve from the elbow, turn counterclockwise to remove.
3. Clean inside of the elbow with hot water.

NOTE

Turn the relief valve towards the left side of the fryer when reinstalling relief valve.

4. Immerse the safety relief valve in soapy water for 24 hours. Use a 1 to 1 dilution rate. The valve cannot be disassembled. It is factory preset to open at 14-½ pounds of pressure. If it does not open or close, replace it!



DO NOT DISASSEMBLE OR MODIFY THIS VALVE!
 Tampering with this valve could cause serious injuries and also voids agency approvals and appliance warranty.

5-28. PRESSURE GAUGE

PRESSURE GAUGE



Cleaning Steps

Recalibrate the pressure gauge if it is out of adjustment.

1. Remove the rim and glass.
2. If the indication hand shows a pressure or vacuum reading when it should stand at "0", turn the recalibrator screw in the same direction in the indicating hand is to be moved until the hand stands at proper "0" position.
3. Replace the rim and glass.

1. Remove the gauge and check inside the pipefittings from dead weight body. Fittings should be clean and open.
2. Clean and reinstall the gauge.

5-29. DRAIN VALVE REMOVAL**Step 3****Step 4**

Find the drain valve underneath the cookpot, in the back of the fryer. Open the drain by pulling the red knob in the front of the fryer, allowing the shortening to drain from the cookpot.

1. Drain the shortening from the cookpot.
2. Remove right side panel of fryer.
3. Remove the two cotter pins from the drain valve fitting and pull extension from the valve.
4. Unscrew the drain shield from the valve.
5. Unscrew drain valve from the cookpot.
6. Replace new drain valve in reverse order.

5-30. NYLATRON SLIDES**Replacement****Step 2**

The Nylatron slides fill the gap in the shroud behind the lid.

1. Remove Cooking Rack and baskets from lid and raise lid.
2. Remove one of the tru-arc rings from the lid pin and pull the pin from the fryer.
3. Lift the lid from the unit.

WARNING

The lid weighs 80 lbs. Take care when lifting the lid to prevent personal injury.

5-30. NYLATRON SLIDES (Continued)



4. Using a 3/8" socket, remove the nuts securing the back shroud.

5. Pull the back shroud off of the threaded studs.

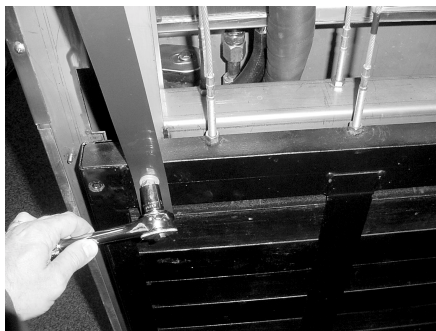

6. Using a 1/2" socket, remove the bolts securing the strips to weights.

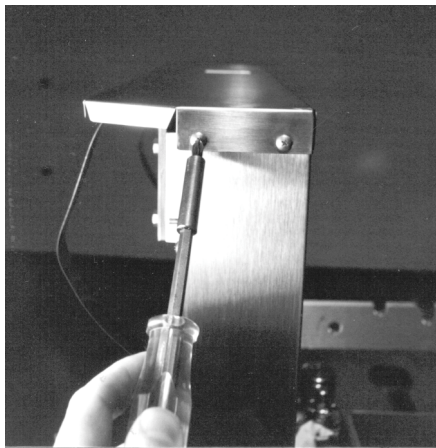

7. Remove screws securing the top shroud and remove shroud.

**5-30. NYLATRON SLIDES
(Continued)**

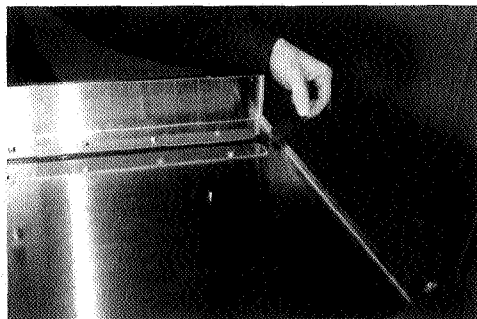
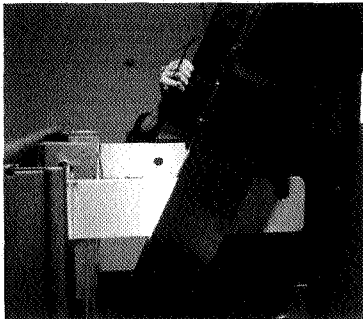
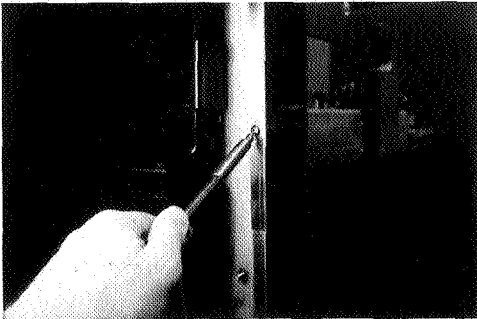

8. Remove the screws securing the front shroud.

9. Remove exhaust hose bracket from front shroud.

10. Lift the front shroud up and out, over the arms of the lid.

11. Thread the new nylatron strip through the track in the front shroud.

12. Lining up the holes in the strips, fit the front shroud over the lid arms and secure to carriage frame.

13. Secure the strips to the weights.

14. Replace the top shroud, back shroud, and lid.

15. Replacement is complete.

LIMITED WARRANTY FOR HENNY PENNY APPLIANCES

Subject to the following conditions, Henny Penny Corporation makes the following limited warranties to the original purchaser only for Henny Penny appliances and replacement parts:

NEW EQUIPMENT: Any part of a new appliance, except lamps and fuses, which proves to be defective in material or workmanship within two (2) years from date of original installation, will be repaired or replaced without charge F.O.B. factory, Eaton, Ohio, or F.O.B. authorized distributor. To validate this warranty, the registration card for the appliance must be mailed to Henny Penny within ten (10) days after installation.

REPLACEMENT PARTS: Any appliance replacement part, except lamps and fuses, which proves to be defective in material or workmanship within ninety (90) days from date of original installation will be repaired or replaced without charge F.O.B. factory, Eaton, Ohio, or F.O.B. authorized distributor.

The warranty for new equipment and replacement parts covers only the repair or replacement of the defective part and does not include any labor charges for the removal and installation of any parts, travel or other expenses incidental to the repair or replacement of a part.

EXTENDED FRYPOT WARRANTY: Henny Penny will replace any frypot that fails due to manufacturing or workmanship issues for a period of up to seven (7) years from date of manufacture. This warranty shall not cover any frypot that fails due to any misuse or abuse, such as heating of the frypot without shortening.

0 TO 3 YEARS: During this time, any frypot that fails due to manufacturing or workmanship issues will be replaced at no charge for parts, labor, or freight. Henny Penny will either install a new frypot at no cost or provide a new or reconditioned replacement fryer at no cost.

3 TO 7 YEARS: During this time, any frypot that fails due to manufacturing or workmanship issues will be replaced at no charge for the frypot only. Any freight charges and labor costs to install the new frypot as well as the cost of any other parts replaced, such as insulation, thermal sensors, high limits, fittings, and hardware, will be the responsibility of the owner.

Any claim must be represented to either Henny Penny or the distributor from whom the appliance was purchased. No allowance will be granted for repairs made by anyone else without Henny Penny's written consent. If damage occurs during shipping, notify the sender at once so that a claim may be filed.

THE ABOVE LIMITED WARRANTY SETS FORTH THE SOLE REMEDY AGAINST HENNY PENNY FOR ANY BREACH OF WARRANTY OR OTHER TERM. BUYER AGREES THAT NO OTHER REMEDY (INCLUDING CLAIMS FOR ANY INCIDENTAL OR CONSEQUENTIAL DAMAGES) SHALL BE AVAILABLE.

The above limited warranty does not apply (a) to damage resulting from accident, alteration, misuse, or abuse; (b) if the equipment's serial number is removed or defaced; or (c) for lamps and fuses. THE ABOVE LIMITED WARRANTY IS EXPRESSLY IN LIEU OF ALL OTHER WARRANTIES, EXPRESS OR IMPLIED, INCLUDING MERCHANTABILITY AND FITNESS, AND ALL OTHER WARRANTIES ARE EXCLUDED. HENNY PENNY NEITHER ASSUMES NOR AUTHORIZES ANY PERSON TO ASSUME FOR IT ANY OTHER OBLIGATION OR LIABILITY.

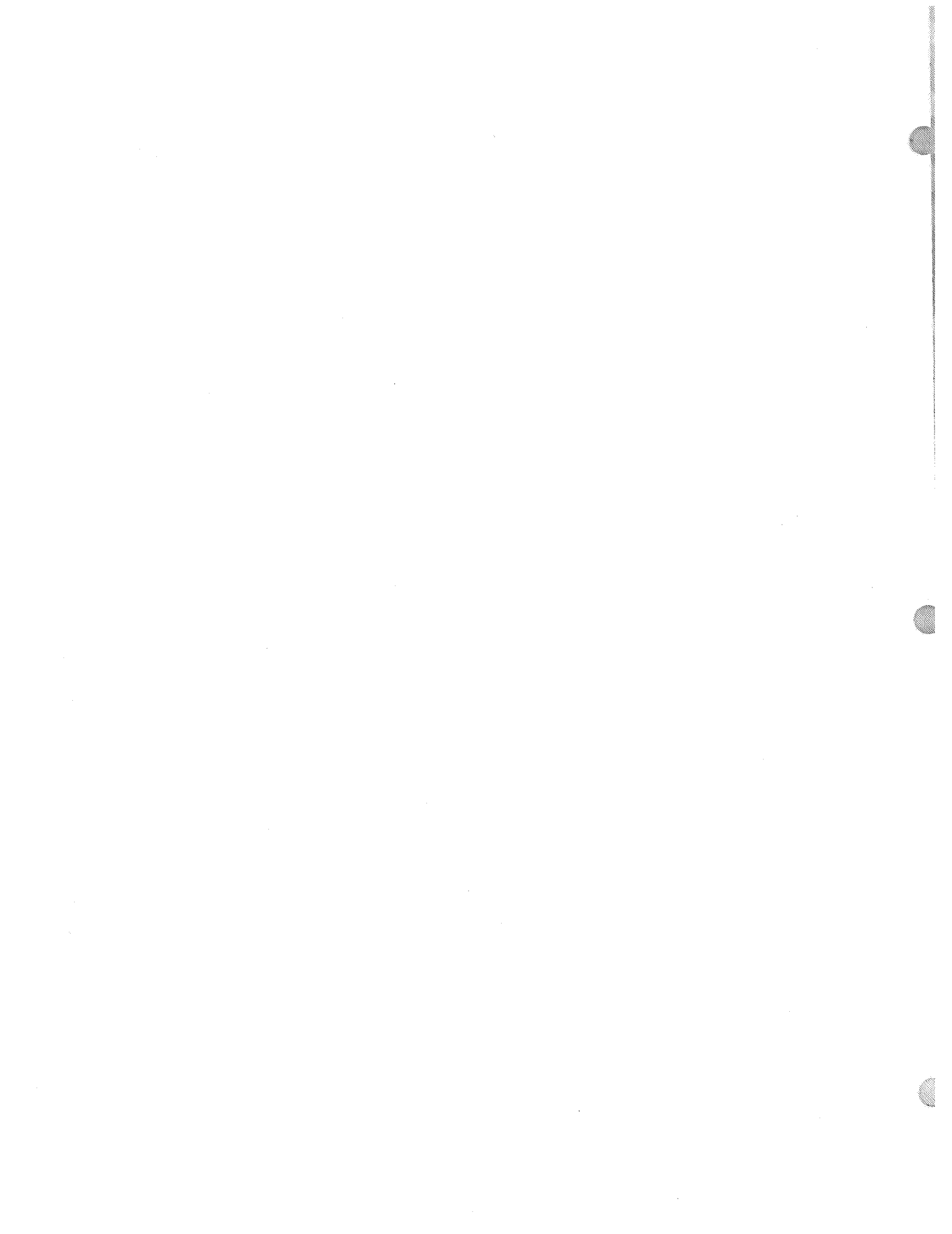

SECTION 6. BASIC PROGRAMMING**6-1. INTRODUCTION**

This section provides programming procedures for the 581 Fryer. The operational controls should be read and understood to become familiar with the control and its functions. If technical assistance is needed, refer to the toll free number printed in this manual.

NOTE

It is recommended to fill out the program worksheet that was shipped with the unit before programming. This will result in less confusion when programming the control.

6-2. PROGRAMMING

1. Move the keyswitch to the PROGRAM position.
2. Depress the SELECT PRODUCT switch to the desired product. The red indicator light will illuminate beside the particular product you are programming.
3. By depressing the SELECT FUNCTION switch, you pick the function to program such as time, temperature, etc. The function you are in will be flashing. Program TIME first.
4. Depress the change switches beneath the digital display until the desired time is displayed. Example: 11 minutes - 11:00.
5. Continue this procedure until you have programmed TIME, TEMPERATURE, ALARM, and PRESSURE.

NOTE

An alarm cannot be programmed on the first interval of any product. Also, when programming temperature, the display will read any temperature between 170° to 390°F. Below 170°F the display will read LO. Above 390°F the display will read HI.

6. By depressing the SELECT TIME switch you can change intervals within that function. You may program up to 10 intervals per function.

**6-2. PROGRAMMING
(Continued)**

7. Load compensation, load anticipation, proportional control, and filter cycle can only be programmed in interval one. When changing to interval two, only time, temperature, alarm, and pressure will illuminate in the function display.
8. Shown on the next page are two examples.

Example 1
 Single Stage Chicken Time: 12 Minutes
 Temperature: 325°F
 Alarm: None
 Pressure: On

INTERVAL

FUNCTION	1	2	3	4	5	6	7	8	9	10
TIME	12 Min.									
TEMPERATURE	325°F									
ALARM	Cannot be programmed on Interval 1						(One interval used)			
PRESSURE	ON									

Example 2
 Two Stage Chicken Time: 13 Minutes 1 Minute Browning - 12 Minutes
 Temperature: 375°F HI 275°F LO
 Alarm: After 1 Minute
 Pressure: On

INTERVAL

FUNCTION	1	2	3	4	5	6	7	8	9	10
TIME	12 Min.	12 Min. 1 Min. Browning								
TEMPERATURE	375°F	275°F								
ALARM	Cannot be programmed on Interval 1	ON					(Two intervals used)			
PRESSURE	ON	ON								

6-3. LOAD COMPENSATION

Load compensation, although factory preset, is programmable. Load compensation adjusts cooking times to compensate for differences in the cooking process such as load size. The control is continuously comparing the pot temperature to the setpoint temperature. If the pot temperature is above the setpoint, then the control will shorten the cook time. If the pot temperature is below the setpoint, then the control will lengthen the cook time. This is programmable within this function by displaying 0 to 10. Zero meaning no load compensation, while ten means the highest load compensation.

6-4. LOAD ANTICIPATION

When dropping a large load of product into the fryer, there is a large temperature drop. On normal controls there is a time period before the thermostat senses this drop. With load anticipation this time period is avoided by turning the heat on as soon as the timer is activated. The heat will remain on until the control senses that the temperature is increasing at which point normal heat control takes over. When programming, the display will read 0° to 10°F. For example: if 5 degrees is programmed, this means the temperature cannot exceed five degrees above setpoint temperature before normal heat control takes over. This is a safeguard or a temperature limit.

6-5. PROPORTIONAL CONTROL

Proportional control regulates pot temperature by pulsing the heat until it reaches setpoint temperature. This allows tighter regulation of pot temperature. The control can be programmed 0 to 30 degrees; zero being no proportional control (best recovery time) and up to thirty degrees meaning the control will pulse the heat off and on thirty degrees before it reaches setpoint (best temperature regulation). Since each product can be programmed with a different proportional control factor, temperature accuracy and recovery time can be tailored to each food product.

6-6. FILTER CYCLE COUNT

The filter cycle count is a method of keeping track of when it is time to filter the shortening. To determine when it is time to filter, the control adds the (fractional) number of the cycle count to a running total at the end of each cook cycle. When this total exceeds one, then the "FIL" ("FIL" within the digital display) indication is given.

An example of this would be as follows:

Product	Programmed No. of Cook Cycles	=	Cycle Count
Chicken	4	=	1/4
Fish	3	=	1/3
Potatoes	2	=	1/2
Vegetables	2	=	1/2

If the operator cooked one cycle of chicken, one cycle of fish, and one cycle of potatoes, the unit would indicate to filter since $1/4 + 1/3 + 1/2 = 1\ 1/2$ which is greater than one. In the event the unit cannot be filtered at the proper time the filter program mode may be bypassed. Turn the power switch to OFF for at least 5 seconds, then turn the unit back to the COOK position. Filter will be bypassed and unit will return to programmed 1st cycle.

6-7. IDLE MODE

The idle mode's main function is to lessen the breakdown of shortening, by programming a lower temperature, when the unit is not in use. The idle mode can be selected by depressing the SELECT PRODUCT switch until the idle mode is indicated. Automatic idle is enabled by programming "A" in the display. Also, the idle time can be programmed. This means the control will select idle automatically after the programmed time has elapsed.

NOTE

If automatic is not programmed, idle must be selected manually. Idle time is programmed from 0 to 255 minutes.

When this is programmed the type of idle can be selected: cycle idle or time idle. This is indicated by a "C" or "T". In cycle idle the programmed time is started every time a new product is selected. In timer idle the programmed time is started at the end of each cook cycle. Depress the SELECT FUNCTION switch. A "C" or "T" will be displayed indicating cycle idle or time idle. Also, the idle temperature can be programmed from 170°F to 390°F. This is normally set at 250°F.

6-7. IDLE MODE (Continued)

The following are four examples of the idle mode.

Example 1: AUTOMATIC IDLE - idle temperature is 250°F and the idle time is 30 minutes. Control is programmed in **cycle idle**. If no product is cooked within 30 minutes, control will automatically select IDLE and regulate at 250°F.

Example 2: AUTOMATIC IDLE - idle temperature is 250°F and the idle time is 30 minutes. Control is programmed in **cycle idle**. **Several loads of different products are cooked**. As long as no more than 30 minutes pass between product selections, the control will not select idle.

Example 3: AUTOMATIC IDLE - idle temperature is 250°F and the idle time is 30 minutes. Control is programmed in **timer idle**. A product is selected and several loads are cooked. As long as a load is cooked within 30 minutes of the last load, the control will not go into idle. If 30 minutes pass between loads, the control will automatically select idle.

Example 4: AUTOMATIC IDLE IS NOT PROGRAMMED - control in manual idle. The control will remain in the product selected by the operator. Operator must use SELECT PRODUCT switch to enter idle mode.

6-8. MELT MODE

The melt mode is used to safely melt solid shortening and can also be used with liquid shortening. Gradually heating or melting the shortening greatly extends its life. This is automatically accomplished in the melt mode by turning the heat on for 3 seconds and off for 27 seconds. The operator has the option of entering melt manually with the SELECT PRODUCT switch or programming automatic melt. Select the melt mode and program "A" for automatic. At this time also program the melt temperature. This is the temperature the control will exit the melt mode and go into the heat mode. It is recommended to program this temperature at 170°F. After programming, the control will work as follows: when the unit is turned on the control checks the pot temperature. If the pot temperature is below 170°F or programmed temperature, the unit will enter the melt mode. If the pot temperature is above 170°F or programmed temperature, the unit will enter the programmed 1st cycle.

NOTE

Once pot temperature exceeds the programmed melt temperature the melt mode cannot be entered.

**6-9. PROGRAMMING 1st
CYCLE**

While in the melt mode, the first cycle can also be programmed. This is the cycle the control will automatically select when in COOK upon exiting the melt mode. It is programmed by selecting the melt mode and depressing the SELECT FUNCTION switch. The green 1st cycle light will flash and the temperature light in the function display will be on. The left half of the product display are numbered from top to bottom, 1 to 6. The right half are numbered 7 to 10. Melt and Idle are not numbered. However, idle can be selected as the first cycle. If number one of the product display is desired as the first cycle, program a number one. If number eight of the product display is desired, program number eight.

NOTE

An unprogrammed product cycle cannot be selected as the first cycle.

**6-10. ONE BUTTON
HENNY PENNY
COOKING PARAMETERS**

The one button programming feature is a simple way for the operator to place Henny Penny's cooking parameters into the control's memory. These programmed cooking cycles are matched with the menu item cards sent with each unit. To achieve this one button programming, follow these steps:

1. Turn the COOK/PROGRAM keyswitch to the PROGRAM position.
2. Depress the TIMER switch. This will put you into the Special Program Mode. The display will read "SP".
3. Using the SELECT PRODUCT switch, select the number 7 product (this will be the top right menu item).
4. Under the digital display there are four switches. Depress the **second** switch from the **right**. The display will show "INIT" briefly and then show "HP" for approximately 2 seconds. The control will then automatically exit the Special Program Mode and enter the Normal Program Mode. All of Henny Penny's cooking parameters are not in the control's memory.

**6-11. TIMING THROUGH
POWER INTERRUPTIONS**

This feature will aid the operator in the event there is a power outage. If the control is timing down and the power supply is interrupted for any reason, the control will not reset to the original cook cycle time. When power is restored, the control will resume timing at the point the power was interrupted, allowing the operator to know what time is needed to finish cooking that particular load of product.

6-12. CLEAN-OUT MODE

The unit has a clean-out mode, which is factory pre-programmed. To enter the clean-out mode, follow the instructions below:

1. Place the keyswitch in the COOK position.
2. Press the SELECT PRODUCT button and select either IDLE or MELT.
3. Press the TIMER button.
4. Display reads “Y” for yes, and “N” for no.
5. If you desire the clean-out mode, press the button below the “Y”. Fryer heats to factory pre-programmed clean-out temperature.
6. If, for any reason, you don’t wish to enter the clean-out mode, depress the button below “N”.
7. After clean-out is complete, turn power switch to OFF and drain contents from fryer.



NEVER PRESSURIZE FRYER TO CLEAN. Leave lid open! Water under pressure is super heated and causes severe burns if contacts skin.

SECTION 7. PARTS INFORMATION

7-1. INTRODUCTION

This section lists the replaceable parts of the Henny Penny Model 581 fryer.

7-2. GENUINE PARTS

Use only genuine Henny Penny parts in your fryer. Using a part of lesser quality or substitute design may result in damage to the unit or personal injury.

7-3. WHEN ORDERING PARTS

Once the parts that you want to order have been found in the parts list, write down the following information:

Item Number	<u> 2 </u>	
Part Number	<u> 16738 </u>	Example:
Description	<u> High Limit </u>	

From the data plate, list the following information:

Product Number	<u> 01100 </u>	
Serial Number	<u> 0001 </u>	Example:
Voltage	<u> 208 </u>	

7-4. PRICES

Your distributor has a price parts list and will be glad to inform you of the cost of your parts order.

7-5. DELIVERY

Commonly replaced items are stocked by your distributor and will be sent out when your order is received. Other parts will be ordered, by your distributor, from Henny Penny Corporation. Normally, these will be sent to your distributor within three working days.

7-6. WARRANTY

All replacement parts (except lamps and fuses) are warranted for 90 days against manufacturing defects and workmanship. If damage occurs during shipping, notify the carrier at once so that a claim may be properly filed. Refer to warranty in the front of this manual for other rights and limitations.

7-7. RECOMMENDED SPARE PARTS FOR DISTRIBUTORS

Recommended replacement parts, stocked by your distributor, are indicated with √ in the parts lists. Please use care when ordering recommended parts, because all voltages and variations are marked. Distributors should order parts based upon common voltages and equipment sold in their territory.

FIGURE & ITEM NO.	PART NUMBER	DESCRIPTION	UNITS PER ASSY
1	35726	COVER, Rear Shroud Stud Assembly.	1
2	36190	CARRIAGE TRACK STUD ASSEMBLY, L.H.	1
3	NS02-005	NUT, (#6-32 Hex Keps).	*
4	35057	SLIDE, Shroud (Inner)	2
5	35248	SLIDE, Shroud (Outer)	2
6	36839	SLIDE.	2
7	62085	WELDMENT, Shroud	1
11	37233	PIN, Stop	2
15	EF02-003	WIRE TIE	*
16	EF02-037	CLAMP	1
17	37143	DEFLECTOR, Steam	1
18	SC01-034	SCREW, Machine (#8-32 x 3/8)	1
19	SC04-003	SCREW, THD Cutting, (#8-32 x 3/8 P PHD TYPE F)	2
20	35053	PANEL, Left Side	1
21	35166	PANEL, Control Weldment (Computron 7000 controls)..	1
22	31299	STUD ASSEMBLY COVER, Control Panel (C7000).....	1
23	31271	HINGE SPRING (Computron 7000 controls).....	2
√ 24	14455	KIT, 581 – C7000 to C8000 – 60 hz.....	1
√ 24	14456	KIT, 581 – C7000 to C8000 – 50 hz.....	1
√ 24	66250RB	ASSY – C8000 – Panel Only.....	1
25	36391	DECAL – C7000.....	1
25	24849	DECAL – C8000.....	1
√ 26	30261	SWITCH, Power (Computron 7000 controls)	1
√ 26	29898	SWITCH. Power (Computron 8000 controls)	1
√ 27	16624	LIGHT, Indicator	1
√ 27	54085	LIGHT, Indicator – Green - CE.....	1
28		Use 14455 or 14456.....	1
29	35881	CONDENSATION PAN ASSEMBLY	1
30	35069	FRAME	1
31	36420	DECAL, Fill Instructions	1
32	37246	CASTER, w/Brake	2
33	35181	COVER, Drain Rod Access.	1
34	SC02-034	SCREW, (#8-AB or A x 1")	2
35	35703	LATCH, Drain Rod	1
36	35705	LATCH RETAINER, Drain Rod	1
37	35919	BLOCK, Latch Mounting.	1
38	SC01-034	SCREW, Machine (#8-32 x 3/8")	2
39	36185	LATCH, Filter	1

√ Recommended Parts
 * As Required

FIGURE & ITEM NO.	PART NUMBER	DESCRIPTION	UNITS PER ASSY
40	35855	LATCH PLATE, Drain Rod	1
41	35899	LATCH PLATE SPACER	1
42	17612	INSERT, Leg Casting	2
43	EF02-072	BUSHING, Split (3/4)	1
44	35107	BRACKET, Drain Rod Weldment	1
45	35154	CASTER	2
46	NS03-017	NUT, (#U Type Clip)	1
47	35179	COVER, Access Cover (Before 12-01-05).....	1
47	36337	COVER, Access Cover (12-01-05 & after).....	1
48	SC02-023	SCREW, (#8-B x 3/8" PH THD SS).....	5
49	35416	WELDMENT, Contactor Bracket	1
50	NS02-002	NUT, (1/4-20 Hex Keps)	6
51	35677	CLAMP, Power Cord	1
52	SC04-011	SCREW, (#8-32 x 1/2" Slot Hex HD SS)	4
53	NS01-015	NUT – ¼-20 HEX (SN: GG015JJ & BELOW).....	2
54	35924	BUSHING PLATE (SN: GG015JJ & BELOW).....	1
55	36075	SPRING, Magnet Plate (SN: GG015JJ & BELOW).....	1
56	LW01-012	LOCKWASHER, (#10 Split Ring SS)	2
57	SC01-055	SCREW, (#10-32 x 3/4" Hex HD SS)	2
58	35923	PLATE/STUD ASSY (SN: GG015JJ & BELOW).....	1
59	35455	PLATE, Magnet Mounting	1
60	WA01-002	WASHER, (1/4 Type B-Series R)	2
61	SC04-006	SCREW, (1/4-20 x 1/2" Hex HD C)	2
62	35515	ANGLE MOUNT	2
63	NS02-010	NUT, (5/16-18 Hex Keps SS)	8
64	SC01-057	SCREW, (1/4-20 x 1/2 Hex HD)	4
65	SC01-042	SCREW, (3/8-16 x 1"Hex HD)	2
66	SC01-104	SCREW, (1/4-20 x 1 1/2" Hex HD)	2
67	LW01-001	LOCKWASHER, (3/8 Split Ring)	4
68	35484	LOCKPLATE, Hookarm	2
69	35299	GUARD, Splash	1
70	36191	CARRIAGE TRACK STUD ASSEMBLY, R.H.	1
71	35490	STOP, Carriage	2
72	NS01-024	NUT, (3/8-16 Hex SS)	*
73	NS01-011	NUT, (#10-32 Hex)	*
74	35954	PLATE, Support Pulley	6
75	18609	RETAINER, Str. Back	1
76	35047	BACK, Shroud	1
77	35962	BRACKET, Wheel Assembly	2
78	36165	BRACE, Carriage Track	2
79	35244	SPACER, Top Frame Brace	2

*As Required
407

FIGURE & ITEM NO.	PART NUMBER	DESCRIPTION	UNITS PER ASSY.
80	35091	TOP FRAME BRACE.....	1
81	SC01-160	SCREW, (1/4-20 x 1 1/4" Hex HD)	4
82	SC01-132	SCREW, (1/4-20 x 5/8" Soc. HD CAP SS	8
83	35725	ADAPTER HOSE EXHAUST	1
√	29524**	KEYSWITCH ASSEMBLY (before Oct. 5, 2001).....	1
√	28980**	RELAY, 12 Volt (before Oct. 5, 2001)	1
√	ME90-007**	RELAY, 240 Volt (before Oct. 5, 2001)	1
√	31900**	SWITCH BOARD (before Oct. 5, 2001).....	1
	36421**	INSULATOR-SWITCH BOARD (before Oct. 5, 2001).	1
	36404**	WIRE BASKET	8
	36374**	BASKET HANDLE.....	2
	38907**	BASKET HANDLE - K-MART	2
	44782**	LID - WIRE BASKET	1
√	26974**	SPEAKER ASSY. (C8000 Controls)	1
	EF02-120**	CONDUIT CLAMP – 1.25” – 2 HOLE (power cord).....	1

√ Recommended Parts

* As Required

** Not Shown

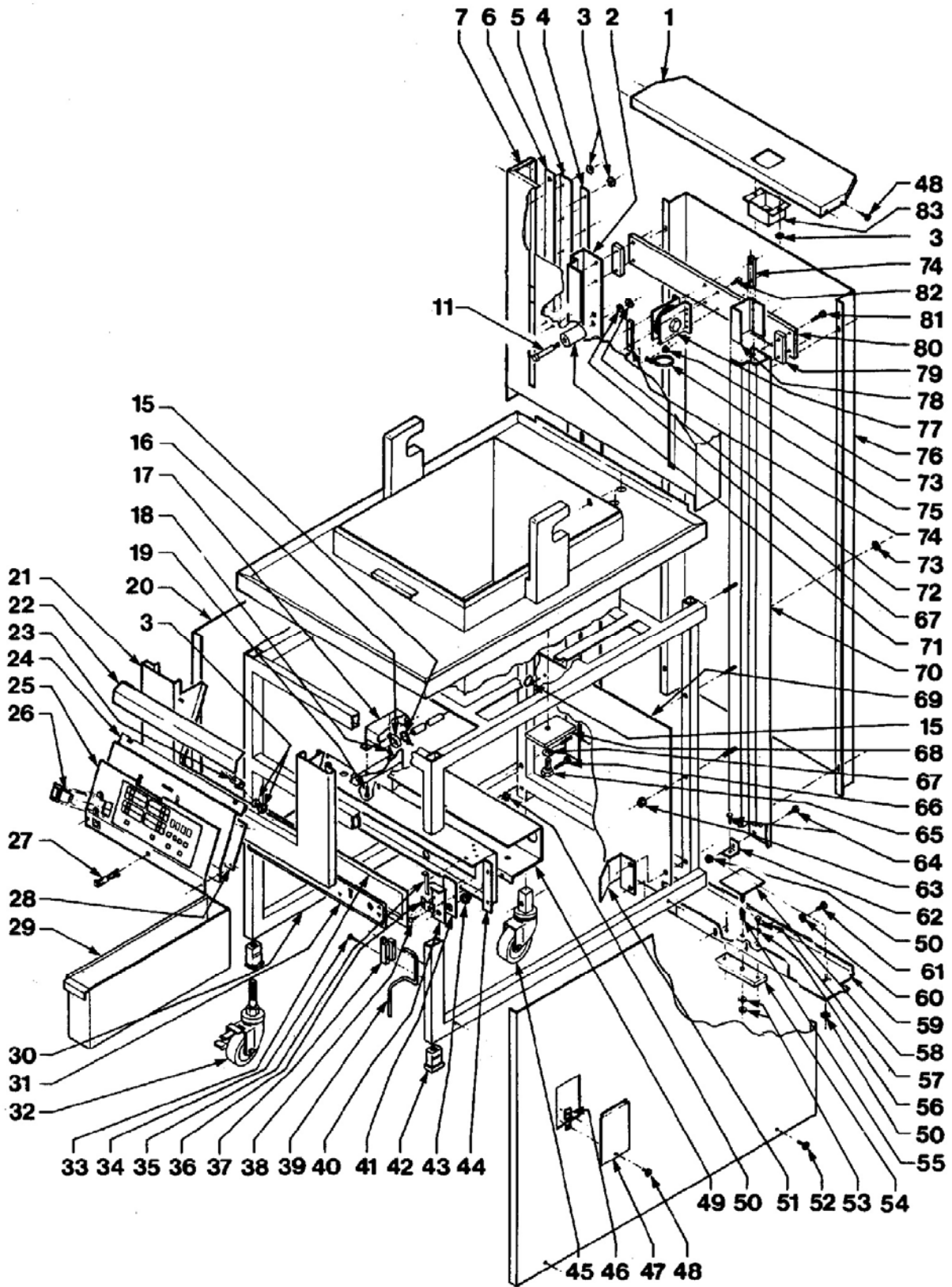

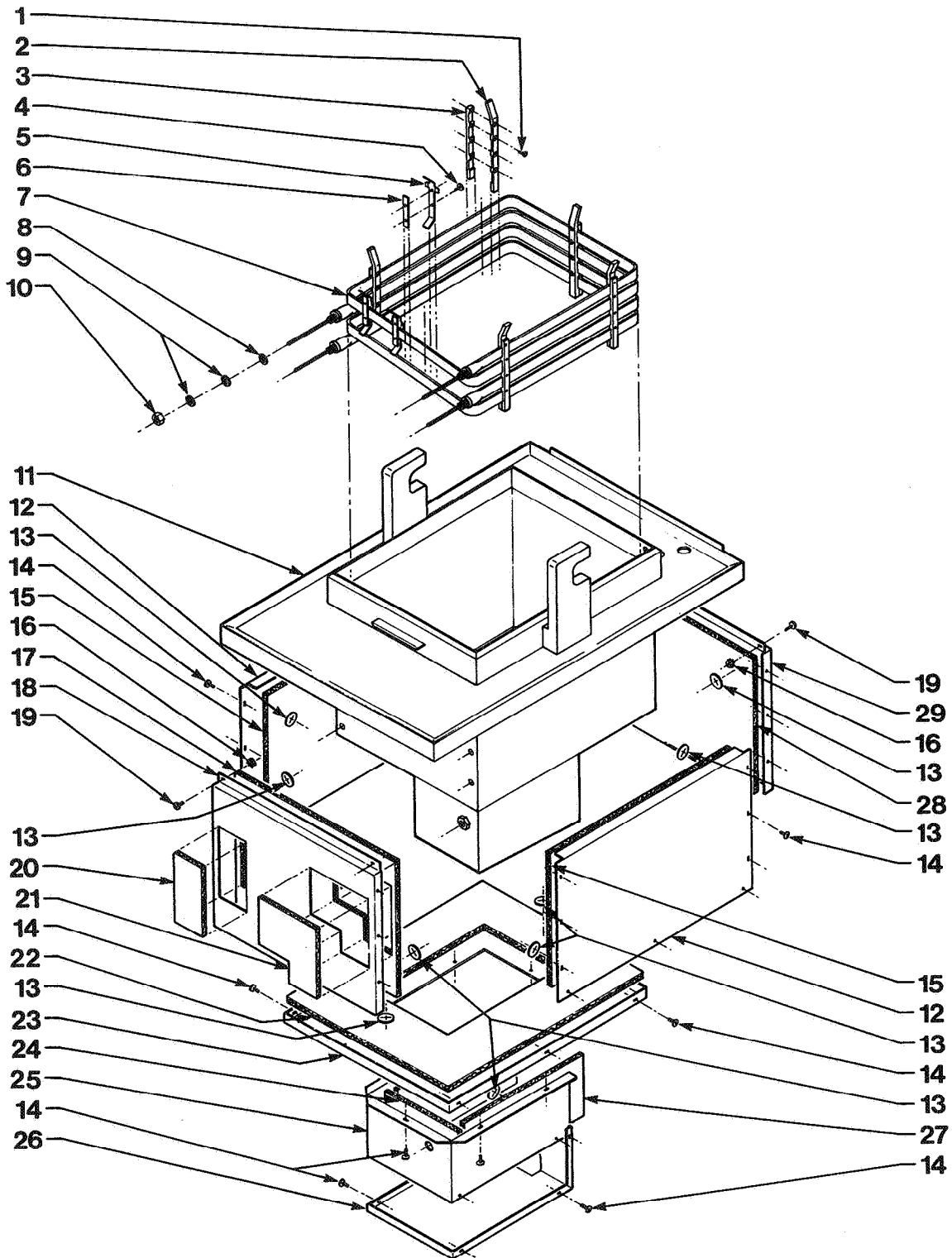

FIGURE & ITEM NO.	PART NUMBER	DESCRIPTION	UNITS PER ASSY
1	SC01-083	SCREW, (#10-32 x 1/2 PH FHD)	*
2	35101	SUPPORT, Element - Long	5
3	35100	SUPPORT, Element - Short	5
4	SCO1-074	SCREW, (#10-32 x 1/2 PH THD S)	*
5	35435	BRACKET, Hi Limit Probe	3
6	35462	BRACKET, Hi Limit Probe	3
√ 7	35234	HEAT ELEMENT ASSEMBLY, 8.5 KW 208V	2
√	35598	HEAT ELEMENT, 8.5 KW 240V	2
√	48367	HEAT ELEMENT, 230 V(Int'l Only)	2
√	36290	HEAT ELEMENT, 220 V(Int'l Only)	2
8	16855	SEAL, O-Ring	4
9	WAO1-005	WASHER, (5/8 Dia. Type A - Series N)	8
10	NSO1-017	NUT, (5/8-18 B Hex)	4
11	Not Avail.	WELDMENT, Pot & Countertop	1
12	35797	WELDMENT, Insul. Box Up. Middle	2
13	WA02-001	WASHER, Insulation 1-1/2 x.015	*
14	SC03-005	SCREW, (#8-AB x .50 PH PHD)	*
15	35519	INSULATION, Side Panel	2
16	NS02-007	NUT, (#8-32 C Hex Keps)	4
17	35326	INSULATION, Upper Front	1
18	35531	WELDMENT, Insulation Box (Front)	1
19	SCO1-053	SCREW, (#8-32 x 1/2 PH RHDS)	1
20	35328	INSULATION, Front Cutout 3.19 x 7.00	1
21	35327	INSULATION, Front Cutout 6.5 x 7.00	1
22	35334	INSULATION, Middle	1
23	35529	WELDMENT, Insulation Box, (Middle)	1
24	35333	INSULATION, Bottom Back	1
25	35528	WELDMENT, Insulation Box, (Bottom)	1
26	35081	BOX, Insulation, Bottom	1
27	35332	INSULATION, Bottom Sides	2
28	35329	INSULATION, Upper Rear	1
29	35530	WELDMENT, Insulation Box, (Rear)	1

√ Recommended Parts

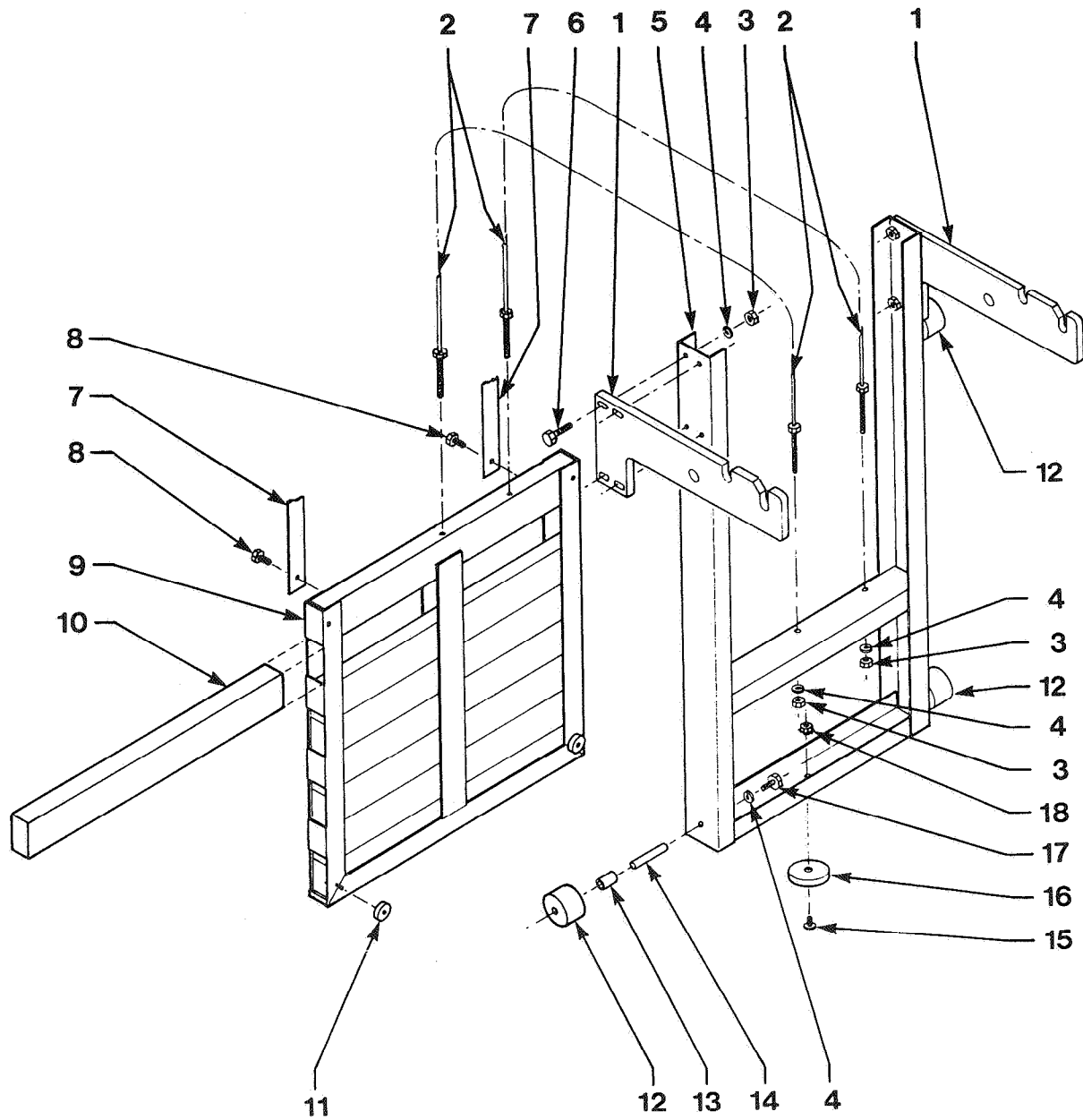

FIGURE & ITEM NO.	PART NUMBER	DESCRIPTION	UNITS PER ASSY.
1	35026	ARM, Lid Support	2
√ 2	35207	CABLE	2
3	NS01-025	NUT, HEX 5/16-18 SS	10
4	LW01-010	WASHER, 3/8 Split Ring SS	10
5	35092	CARRIAGE	1
6	SC01-069	SCREW, 3/8-16 x 1-1/2 Hex HD S2P	8
7	36839	SLIDE	2
8	SC01-042	SCREW, 3/8-16 x 1 Hex C	2
9	36625	WELD ASSEMBLY, C/W Carriage	1
10	36627	COUNTERWEIGHT BAR	7
11	36626	SPACER, C/W Frame	2
12	37362	WHEEL, Carriage	4
13	37363	SPACER, Carriage Wheel	4
14	37364	SPINDLE	4
15	SC01-009	SCREW, 1/4-20 x 1/2 P THD	1
16	35438	MAGNET, Ceramic (Small)	1
17	SC01-081	SCREW, 3/8-24 x 3/4 Hex HD SS	4
18	NS02-002	NUT, 1/4-20 Hex Keps	1

√ Recommended Parts

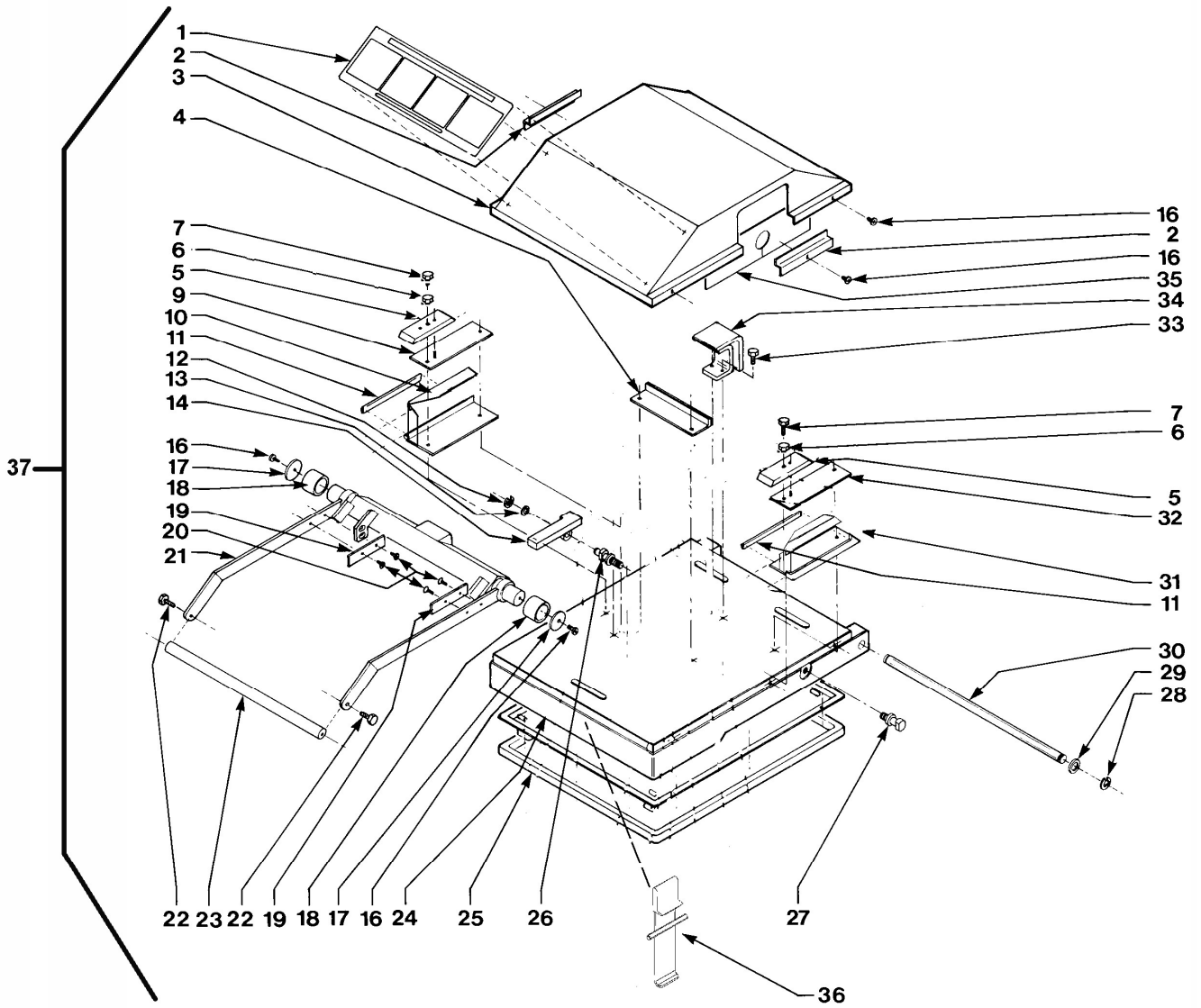

FIGURE & ITEM NO.	PART NUMBER	DESCRIPTION	UNITS PER ASSY
1	35792	LID INSTRUCTION LABEL	1
2	35675	FILLER, Lid	2
3	35243	COVER, Lid, Main.....	1
4	35413	PLATE, Trip	1
√ 5	52627	Pressure Pad Assembly.....	2
5	49864	Pressure Pad (use 52627).....	2
6	49852	Bushing (not shown).....	2
7	SC01-204	Screw 1/4-20 x 1.00 Sock Butt Hd	2
8	37171	SHIM, Lid (.030).....	1
9	49962	PLATE, Shim Assembly (L.H.)	1
10	49890	PLATE, Cam Guide (L.H.).....	1
11	35359	SLIDE, (6").....	2
12	16121	RING, (Tru-Arc) Latch Pin	1
13	WA01-020	WASHER, Lid Stop.....	1
14	51531	CAST, Lid Stop	1
16	SC01-074	SCREW, #10-32 x 1/2 PH THD SS	8
17	35223	WASHER, Special.....	1
18	35227	ROLLER, Linkage Shaft	2
19	35339	GUIDE, Handle Side	2
20	SC01-062	SCREW, #6-32 x 3/8 PH FH.....	4
22	SC01-041	SCREW, 5/16-18 x 1.00 Hex HD C	2
23	36285	WELDMENT, Handle Tap Plate.....	1
√ 25	34526	GASKET, LID - SN: AC0712021 & below	1
√ 25	66620	GASKET, LID - SN: AC0712022 & above	1
26	35945	PIN, Lid Support.....	1
27	35032	PIN, Lid Support.....	1
28	RR01-010	RING, Ret. 3/4 Shaft SS	2
29	36312	WASHER, Lid Hinge	2
30	51697	PIN, Lid Hinge.....	1
31	49895	PLATE, Cam Guide (R.H.)	1
32	49963	PLATE Shim Assembly (R.H.)	1
33	SC01-146	SCREW, 1/4-20 x 3/4 Hex HD SS	2
34	52477	LIFT, Lid	1
√ 35	35465	CAM SLIDE FILLER	2
36	52497	LATCH ASSEMBLY, Coated	1
37	72377	ASSY – REBUILT LID	1
38	52498	LATCH SPRING (not shown)	1
39	SC01-214	SCREW, Latch, 10-32 x 1 PH THD SS (not shown).....	2
40	LW02-006	LOCKWASHER, Latch (not shown).....	2
41	52728	SHIM, Lid Lift (not shown).....	1

√ Recommended Parts

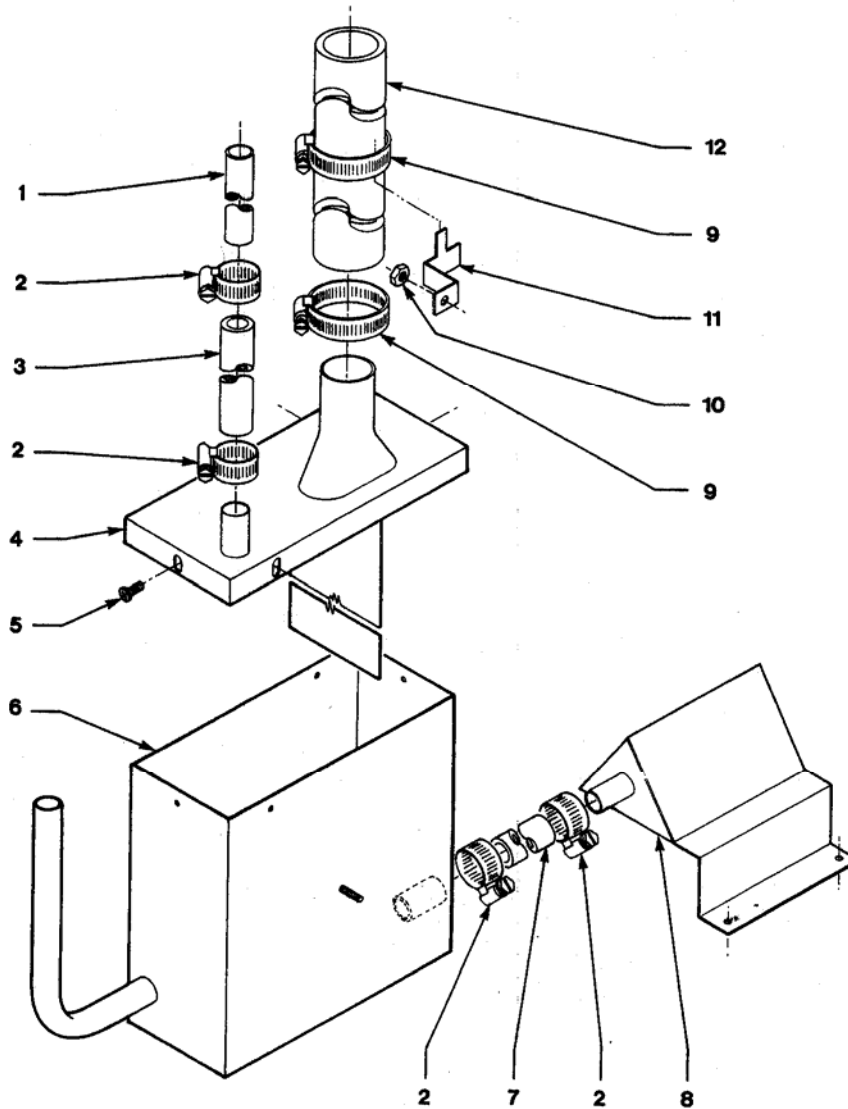

FIGURE & ITEM NO.	PART NUMBER	DESCRIPTION	UNITS PER ASSY.
1	35686	TUBE, DW to Exhaust Stack SS	1
2	MS01-297	HOSE CLAMP, SS - .500 - 1.062 DID.....	4
3	35693	TUBE, Exhaust Connect	1
4	35696	WELDMENT, Steam Exhaust Box Lid.....	1
5	SC02-014	SCREW, #8 AB x 3/8 P THD SS	4
6	35687	WELDMENT, Steam Exhaust Box	1
7	35694	TUBE, Condensate.....	1
8	70312	ASSEMBLY, Restrictor Weld.....	1
9	MS01-315	HOSE CLAMP, 1/2 x 1-3/4 SS.....	2
10	NS01-011	NUT, (#10-32 Hex).....	1
11	36851	BRACKET, Hose.....	1
12	21877	TUBING, Steam Exhaust.....	4

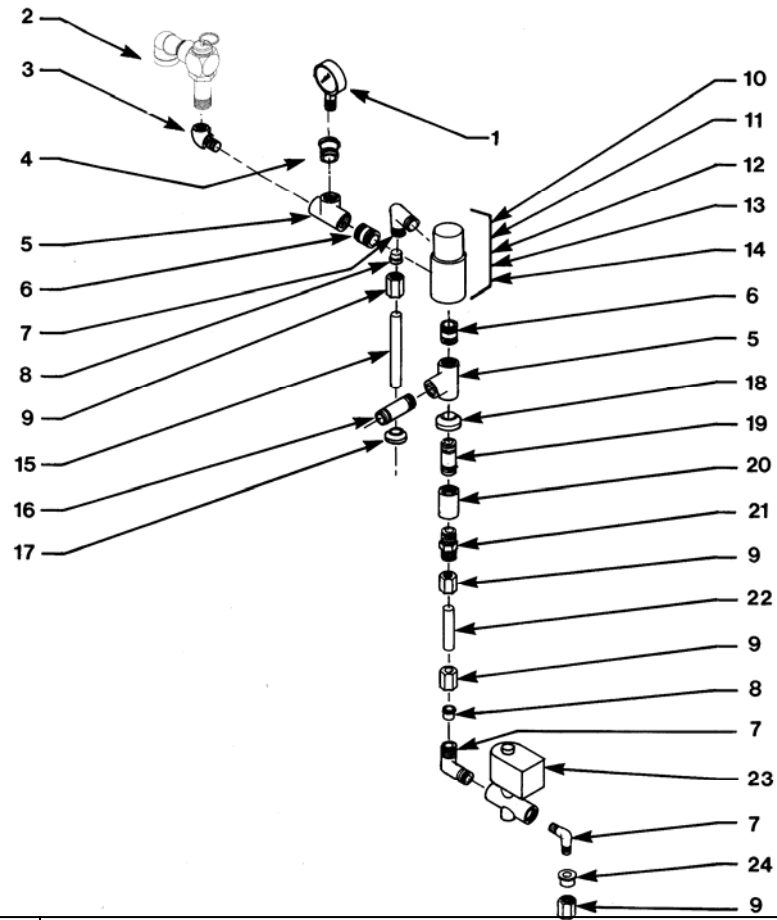

FIGURE & ITEM NO.	PART NUMBER	DESCRIPTION	UNITS PER ASSY
√ 1	16910	PRESSURE GAUGE.....	1
√ 2	59742	RELIEF VALVE ASSY.....	1
3	FP01-127	ELBOW, Street, ½ x ½, 90 Degree.....	1
4	FP01-063	REDUCER, ½ NPT M to ¼ NPT F.....	1
5	FP01-011	PIPE TEE, ½ NPT 304 SS.....	2
6	FP01-028	NIPPLE, Close ½ NPT.....	2
7	17407	CONNECTOR, ½ Male Elbow.....	3
8	16817	FITTING, Sleeve Teflon.....	*
9	16809	NUT FITTING.....	*
10	56307	CAP, Dead Weight.....	1
11	16902	SEAL "O" RING.....	1
12	16904	DEAD WEIGHT - 9#.....	1
13	16906	ORIFICE, 9 PSI.....	1
14	16852	BODY, Valve.....	1
15	35686	TUBE, DW to Exhaust Stack.....	1
16	35817	PIPE NIPPLE, ½ x 2 ¼ SS.....	1
17	16804	UMBRELLA GROMMET.....	1
18	35200	UMBRELLA GRAMMET.....	1
19	35474	PIPE NIPPLE, ½ x 2.....	1
20	FP01-066	COUPLING, ½ NPT SS.....	1
21	16807	FITTING CONNECTOR, Male.....	1
22	35147	TUBE, Steam Exhaust - Up.....	1
23	18721	VALVE, Solenoid.....	1
24	16808	FITTING SLEEVE, Steel.....	1

√ Recommended Parts

FIGURE & ITEM NO.	PART NUMBER	DESCRIPTION	UNITS PER ASSY.
1	19683	BRACKET, Mercury Contactor	1
√ 2	29942	CONTACTOR, Mercury 208/240 VAC	1
√ 2**	65075	E/M HEAT CONTACTOR-CE-240V (UK)	1
√ 2**	65074	E/M HEAT CONTACTOR-CE-230V	1
3	SC04-003	SCREW, #8-32 x 3/8 P PHD	2
4	35416	WELDMENT, Contactor Bracket	1
5	NS02-005	NUT, #6-32 Hex Keps	*
6	35107	BRACKET, Drain Rod Weldment	1
√ 7	EF02-006	FUSE HOLDER	2
√ 8	EF02-007	FUSE, 15 Amp	2
9	SCO1-010	SCREW #6-32 x 1/2 PH PHD	4
√ 10	MS01-197	RECEPTACLE, NEMA 5-15	1
10	56063	CORD ASSY, - CE	1
10	14721	KIT, 580 Receptacle Non-CE to CE	1
11	16102	SPINDLE KNOB, Red	1
12	17216	BRACKET, Hi-Limit Probe	1
√ 13	16738	TEMP. CONTROL, Hi-Limit - 450F	1
14	SC04-004	SCREW, #8-32 x 3/8 P PHD	2
√ 15	18227	MICROSWITCH	1
16	35132	DRAIN ROD HANDLE	1
17	55139	LEVER – DRAIN VALVE	1
18	PN01-012	CLEVIS PIN, 1/4 x 1 SS	1
19	PN01-002	COTTER PIN, 3/32 x 3/4 S	1
20	35521	SPLASH GUARD ASSEMBLY	1
21	55137	DRAIN VALVE & COUPLING ASSEMBLY.	1
22	17255	COTTER PIN, 9/64 x 1 ¼	2
23	19405	CONTACTOR 208/240 VAC	1
√ 24	55167	PROBE, Temperature (Not Shown)	1
25	56065	ADAPTOR, CORD ASSY. – 580 to PF-180 (used in conjunction with 56063 with units of SN: AG005II and below) (Not Shown)	1
26	54010	Cord & Plug Assembly (Not Shown)	1
	35192	Plug – 120/208 – 4P, 5W, 60 Amp	1
	35476	Cord Assembly	1
27	19923	TRANSFORMER, 480V (Not Shown)	1
		<u>Additional Parts for the European Community Units</u>	
√	51057	FILTER, ASSEMBLY-EMC (Not Shown)	1
	48369	SWITCH, COVER- Plastic (Not Shown)	1

Recommended Parts

**Not Shown

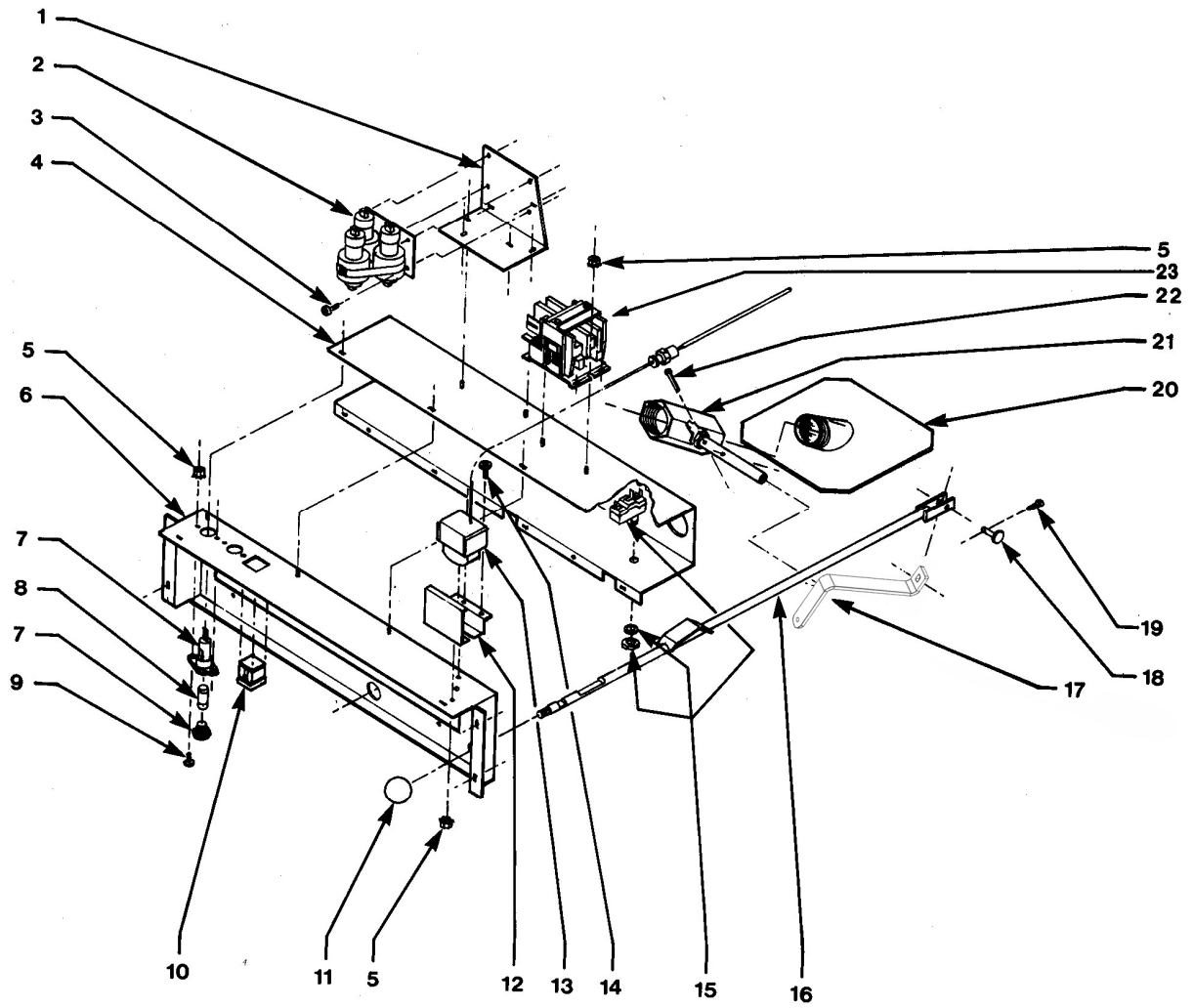
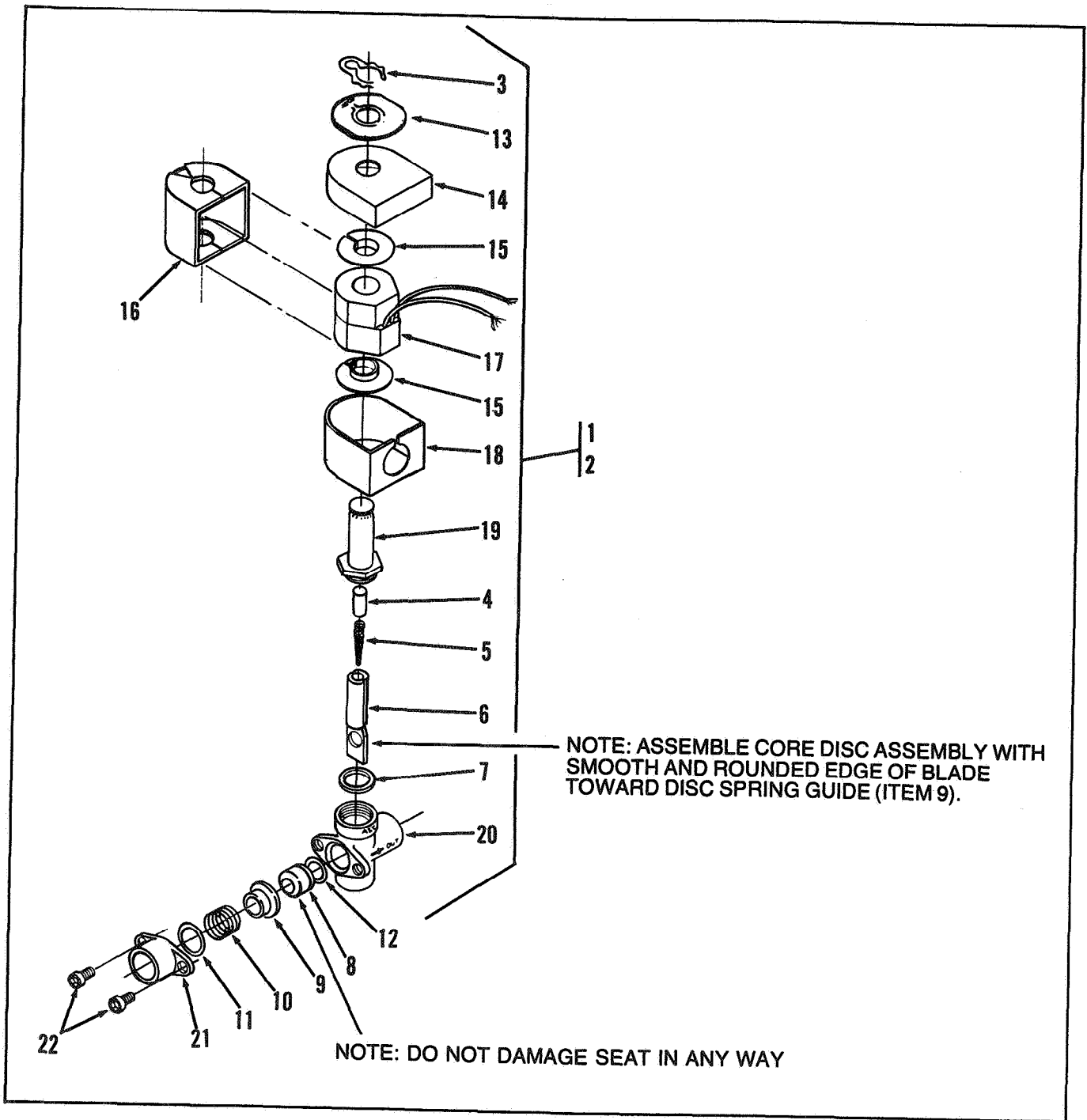
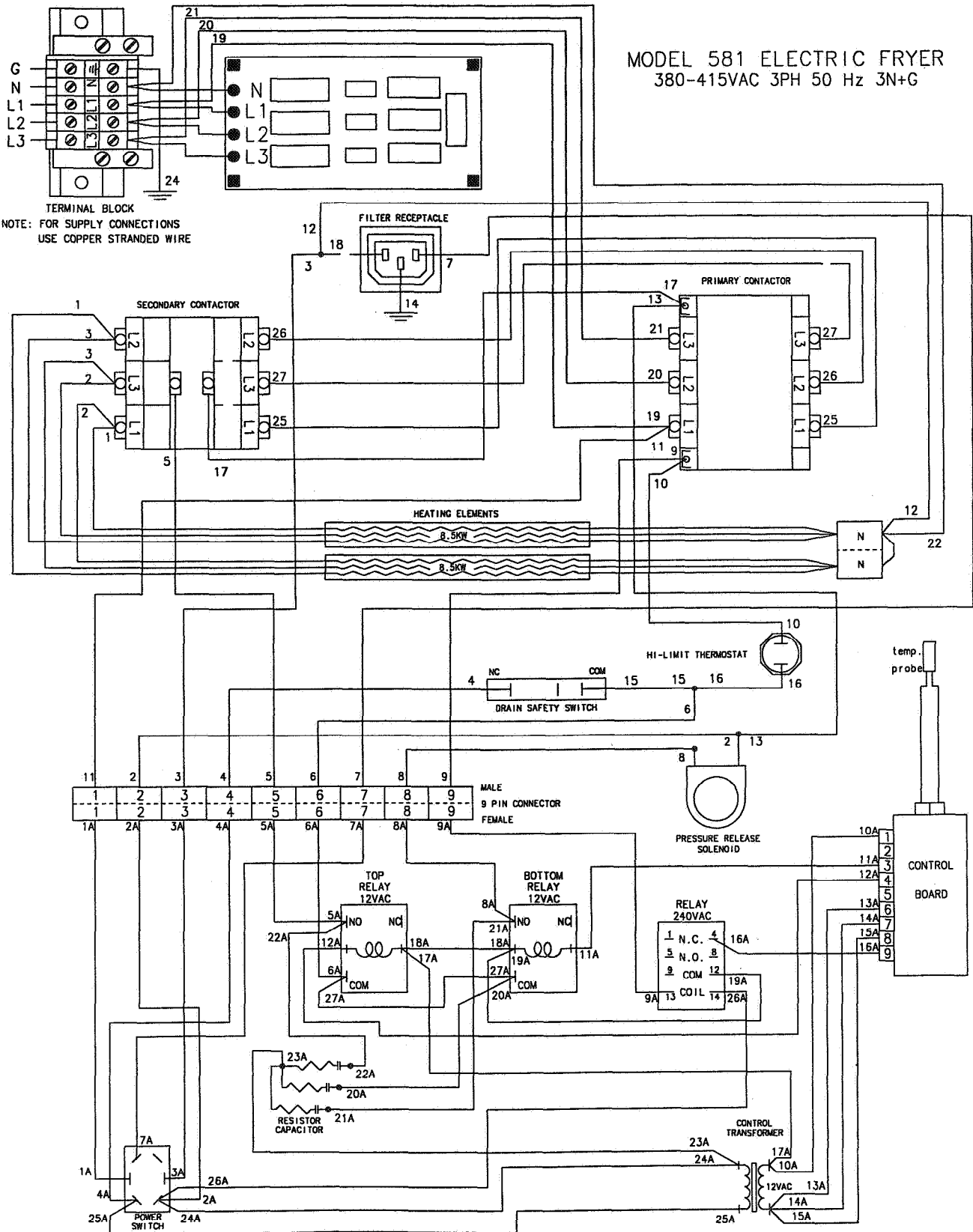

FIGURE & ITEM NO.	PART NUMBER	DESCRIPTION	UNITS PER ASSY.
3-7		SOLENOID VALVE ASSEMBLY	
1	17121	VALVE, SOLENOID 120V, 60 Hz	1
1	18721	VALVE, SOLENOID 208-240V, 60 Hz	1
1	18724	VALVE, SOLENOID 208-240V, 50 Hz	1
√ 2*	17120	KIT, SOLENOID VALVE REPAIR	1
3	17101	CLIP, RETAINER	1
4	17109	RETAINER, SPRING	1
5	17110	SPRING, CORE	1
6	17111	CORE, DISC ASSEMBLY	1
7	17112	GASKET, BONNET	1
8	17114	SEAT, TEFLON	1
9	17115	GUIDE, DISC SPRING	1
10	17116	SPRING, DISC	1
11	17117	RING, SPRING RETAINER	1
12	17122	SEAT, O-RING SEAL	1
√ 13	17102	PLATE, SOLENOID NAME	1
√ 14	17103	COVER, COIL HOUSING	1
√ 15	17104	WASHER, COIL	2
√ 16	17105	YOKE, COIL	1
√ 17	17106	COIL, 120V, 60 Hz	1
√ 17	18706	COIL, 208-240V, 60 Hz	1
√ 17	18726	COIL, 208-240V, 50 Hz	1
√ 18	17123	HOUSING, COIL	1
√ 19	17108	BONNET, SOLENOID	1
√ 20	17113	BODY, SOLENOID VALVE	1
√ 21	17118	ADAPTER, PIPE	1
√ 22	SC01-132	SCREW, ADAPTER	2

√ recommended parts
 * not shown



Solenoid Valve Assembly



51202

NOTE: FOR SUPPLY CONNECTIONS
USE COPPER STRANDED WIRE

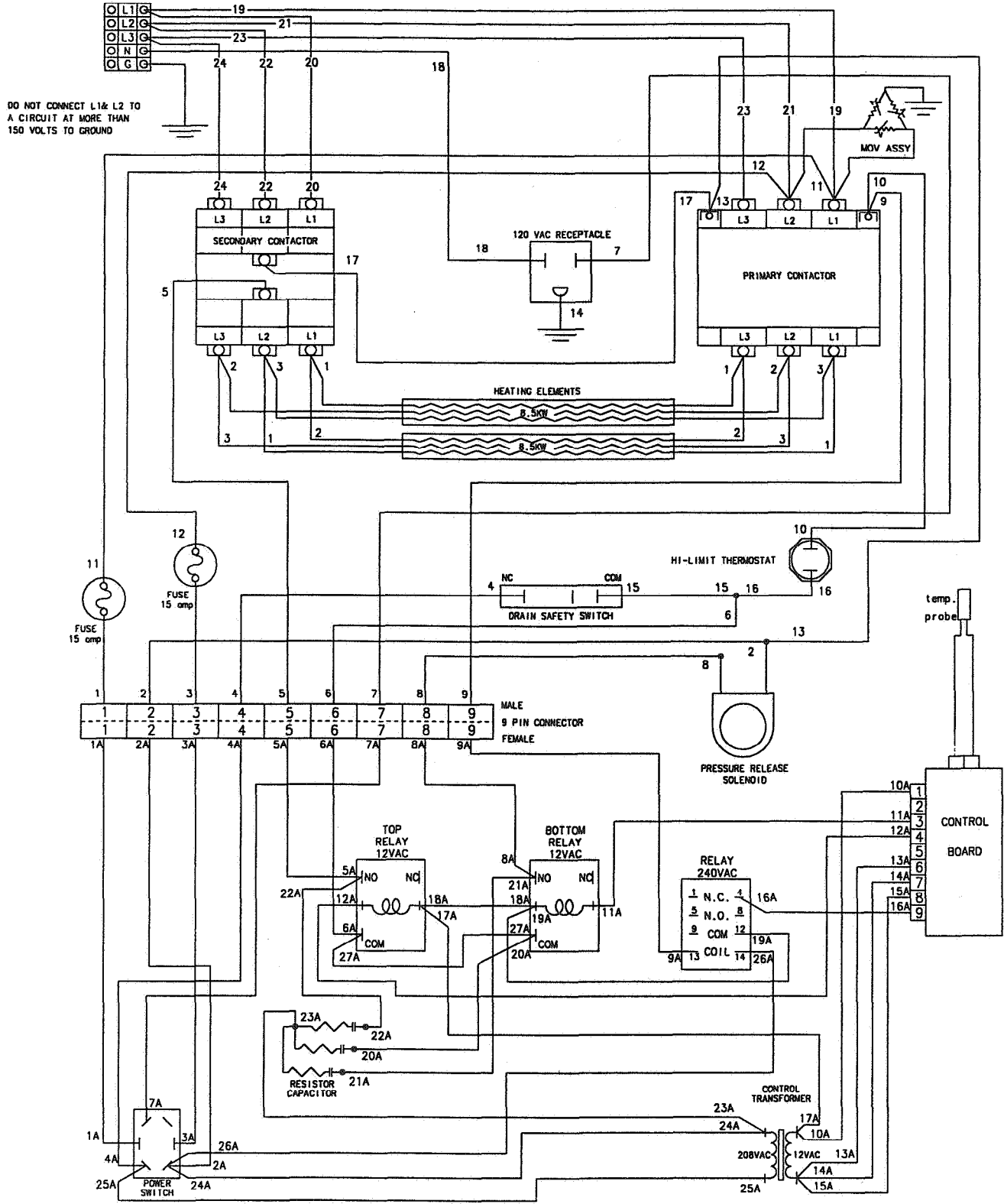

MODEL 581 ELECTRIC FRYER
17KW 120/208VAC
3PH 4WIRE W/GRND

36381

NOTE: FOR SUPPLY CONNECTIONS
USE COPPER STRANDED WIRE

DO NOT CONNECT L1& L2 TO
A CIRCUIT AT MORE THAN
150 VOLTS TO GROUND

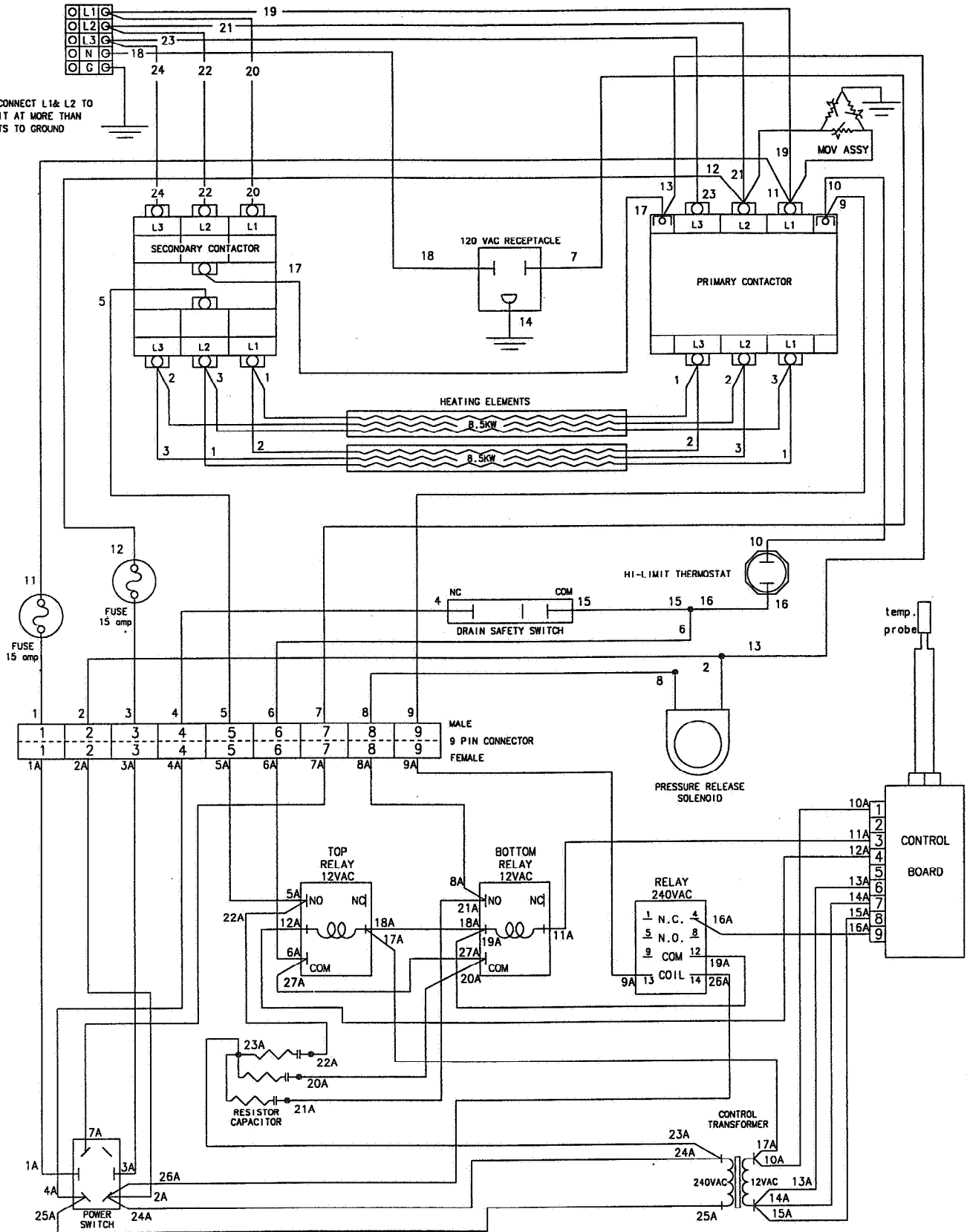

MODEL 581 ELECTRIC FRYER
17KW 120/240VAC
3PH 4WIRE W/GRND

36382

200

NOTE: FOR SUPPLY CONNECTIONS
USE COPPER STRANDED WIRE

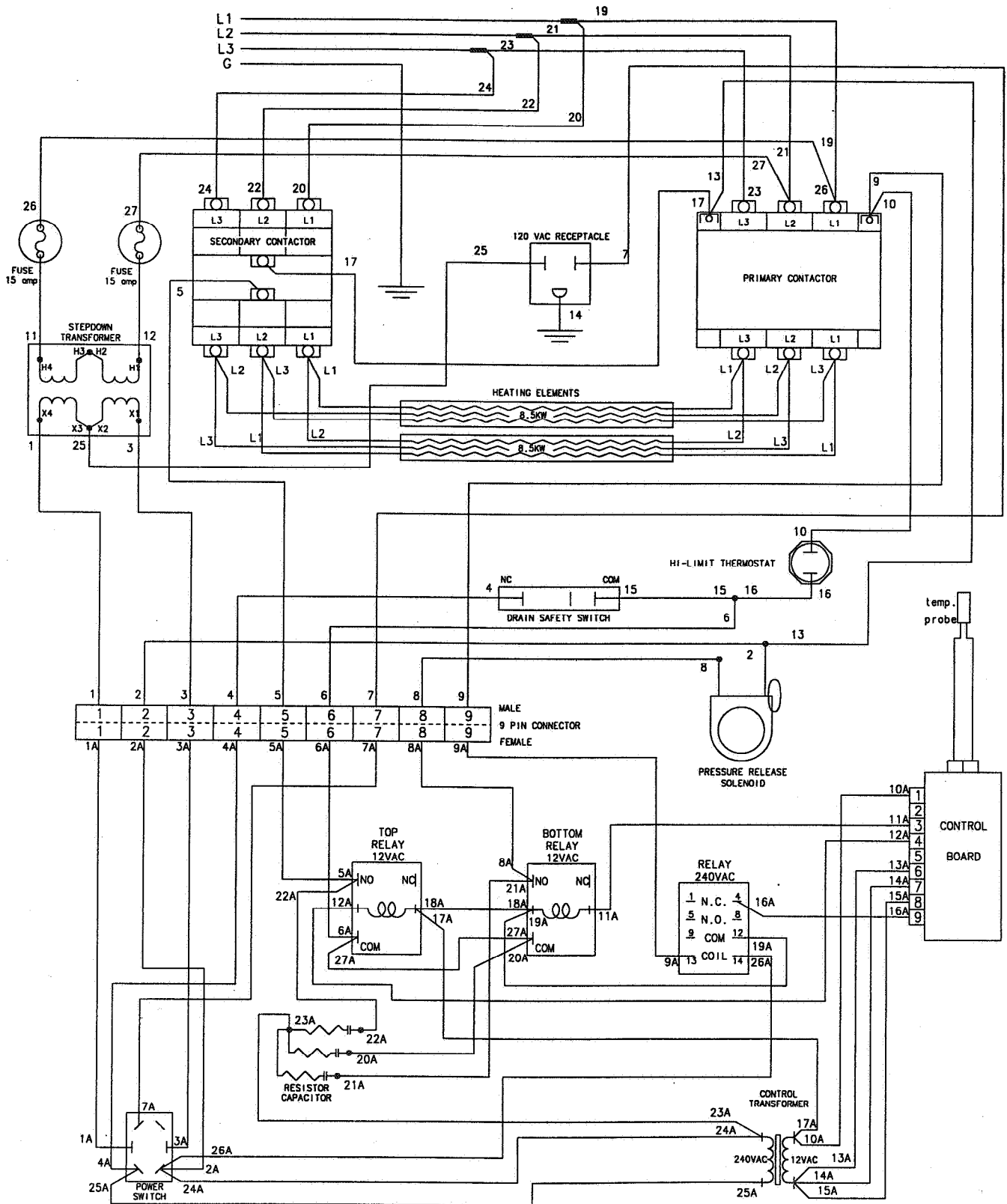

MODEL 581 ELECTRIC FRYER
17KW 480VAC
3PH 3WIRE W/GRND

36383

NOTE: FOR SUPPLY CONNECTIONS
USE COPPER STRANDED WIRE

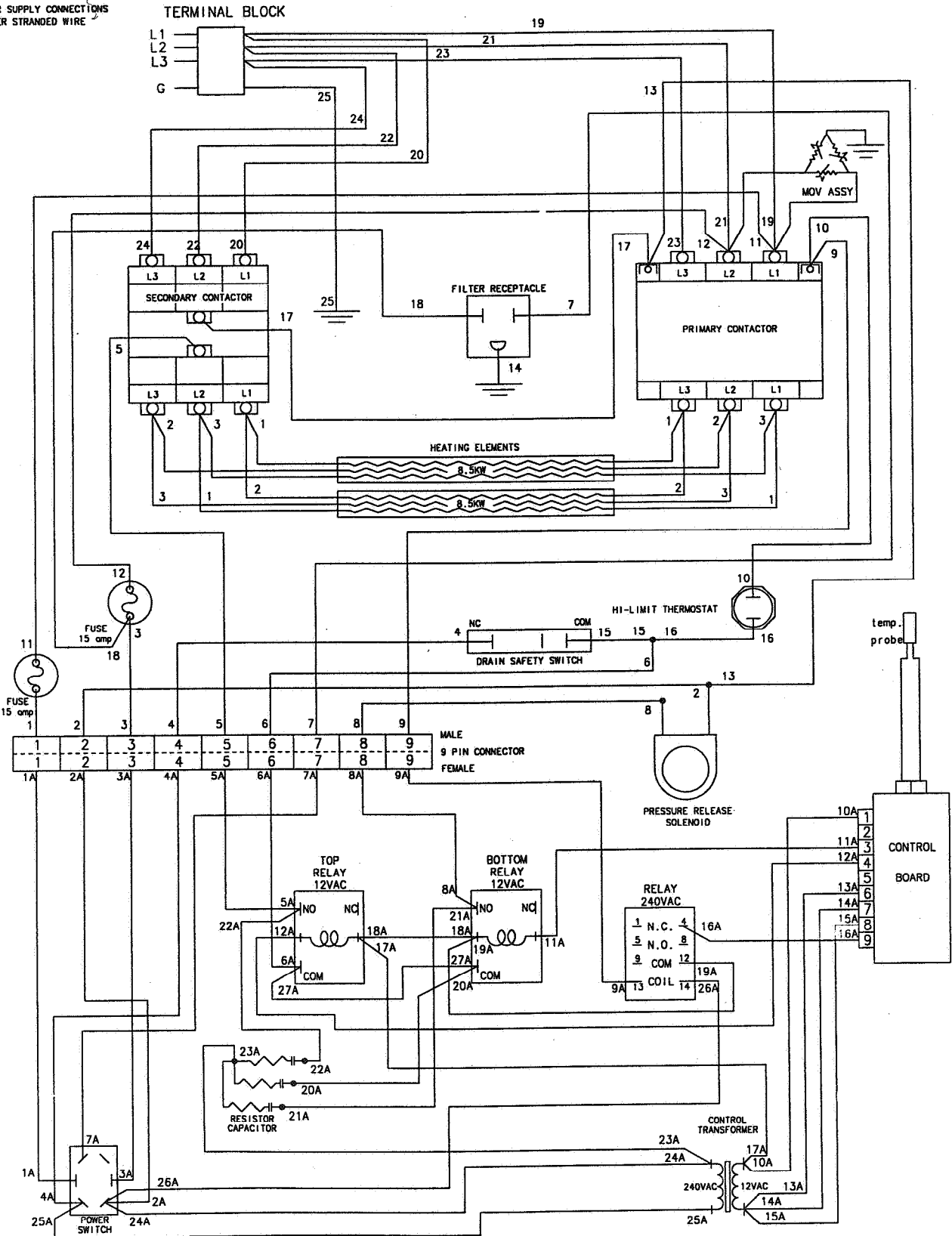

MODEL 581 ELECTRIC FRYER
17KW 240VAC
3PH 50HZ 3W+G

36384

NOTE: FOR SUPPLY CONNECTIONS
USE COPPER STRANDED WIRE

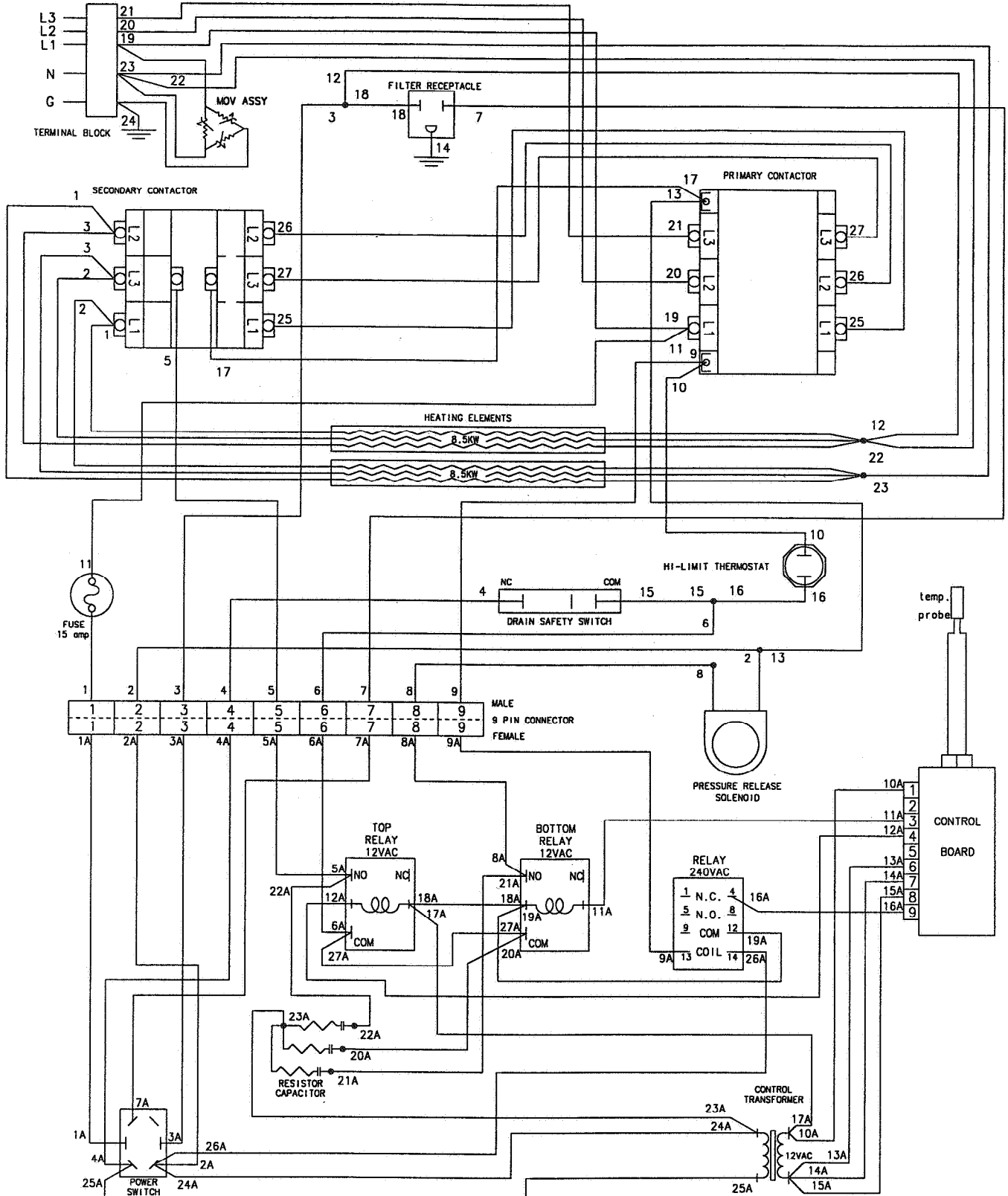

MODEL 581 ELECTRIC FRYER
380VAC 3PH 50HZ 4W+G
OR
415VAC 3PH 50HZ 4W+G

POWER	TRANSFORMER TAP
380	208V
415	240V

36385

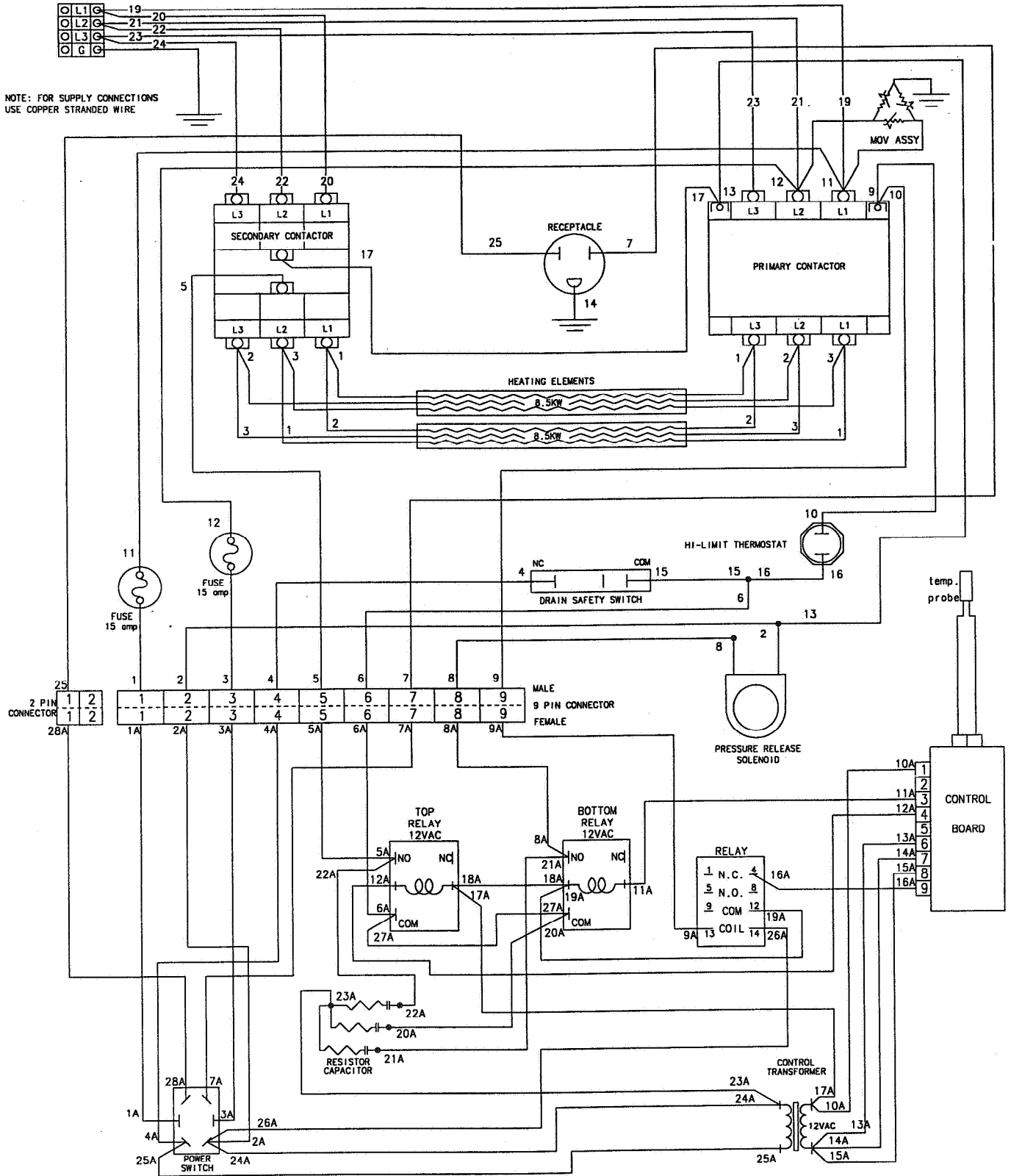

MODEL 581 ELECTRIC FRYER
17KW 208V 50-60HZ 3PH 3WIRE+GND
OR
17KW 240V 60HZ 3PH 3WIRE+GND

36890

Wiring Diagram for Units Built after Oct. 5, 2000

NOTE: FOR SUPPLY CONNECTIONS
USE COPPER STRANDED WIRE

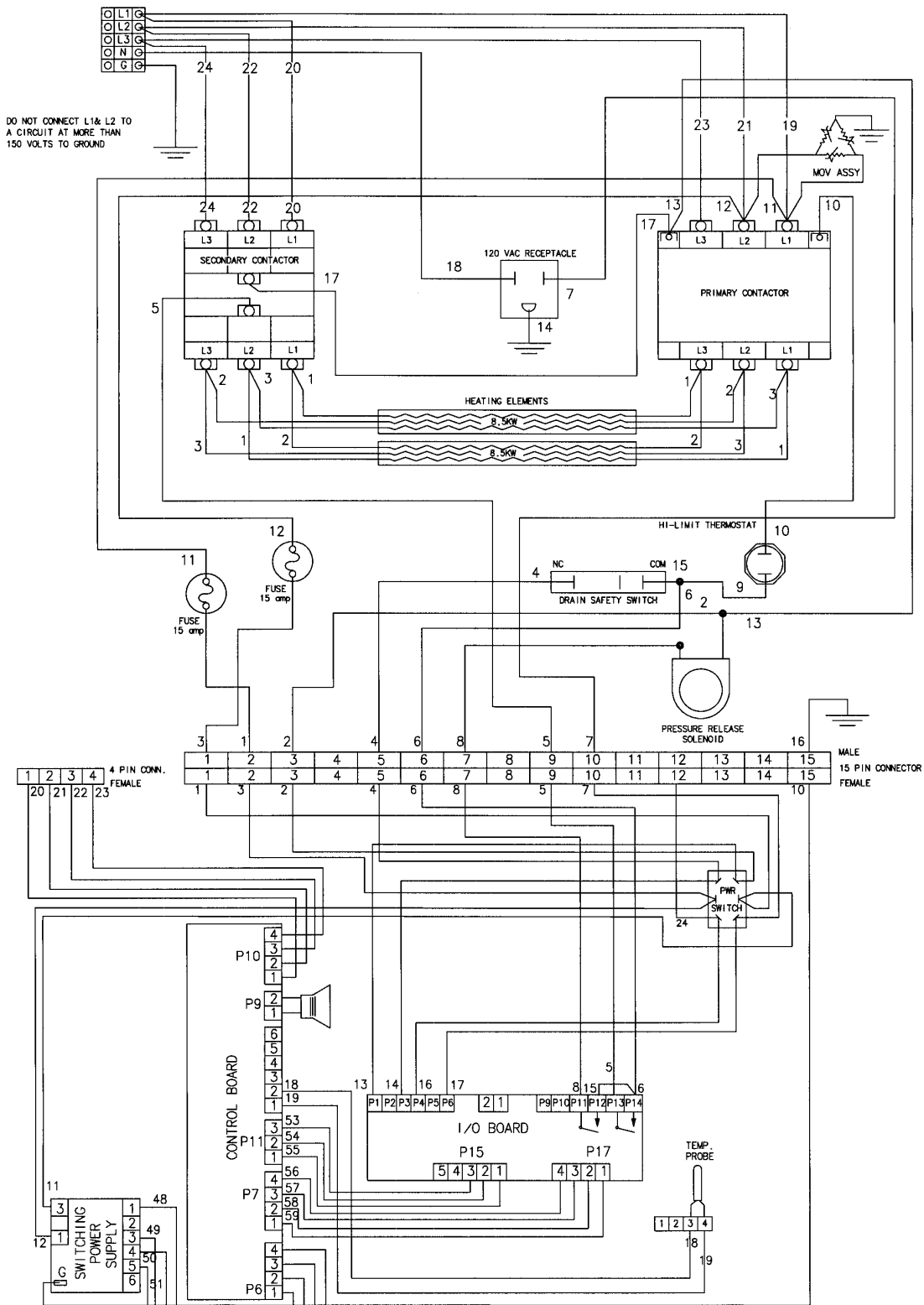

MODEL 580 ELECTRIC FRYER
17KW 120/208VAC OR 120/240VAC
3PH 4WIRE W/GRND

56820

Wiring Diagram for Units Built after Oct. 5, 2000

NOTE: FOR SUPPLY CONNECTIONS
USE COPPER STRANDED WIRE

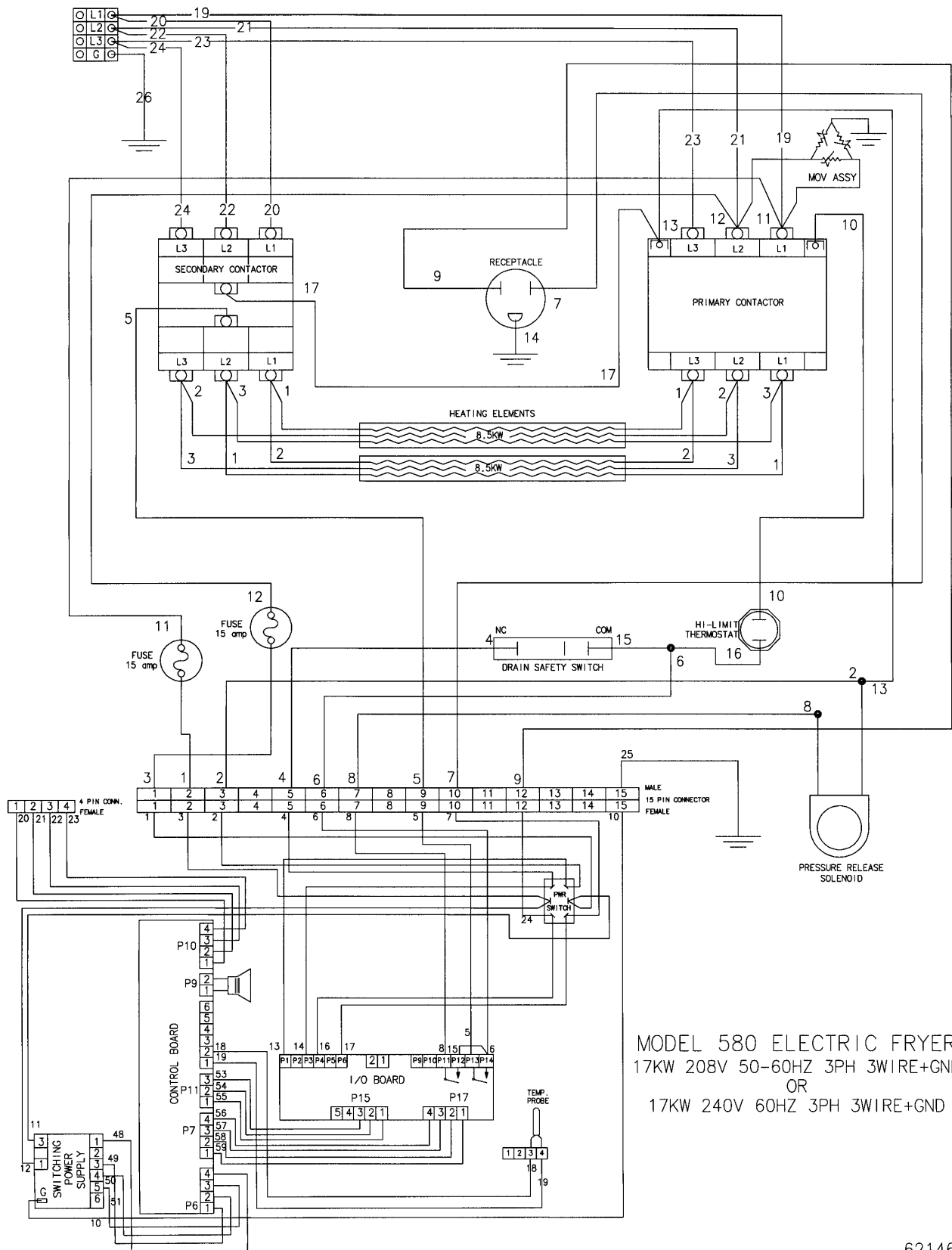

MODEL 580 ELECTRIC FRYER
17KW 208V 50-60HZ 3PH 3WIRE+GND
OR
17KW 240V 60HZ 3PH 3WIRE+GND

62146

Wiring Diagram for Units Built after Oct. 5, 2000

NOTE: FOR SUPPLY CONNECTIONS
USE COPPER STRANDED WIRE

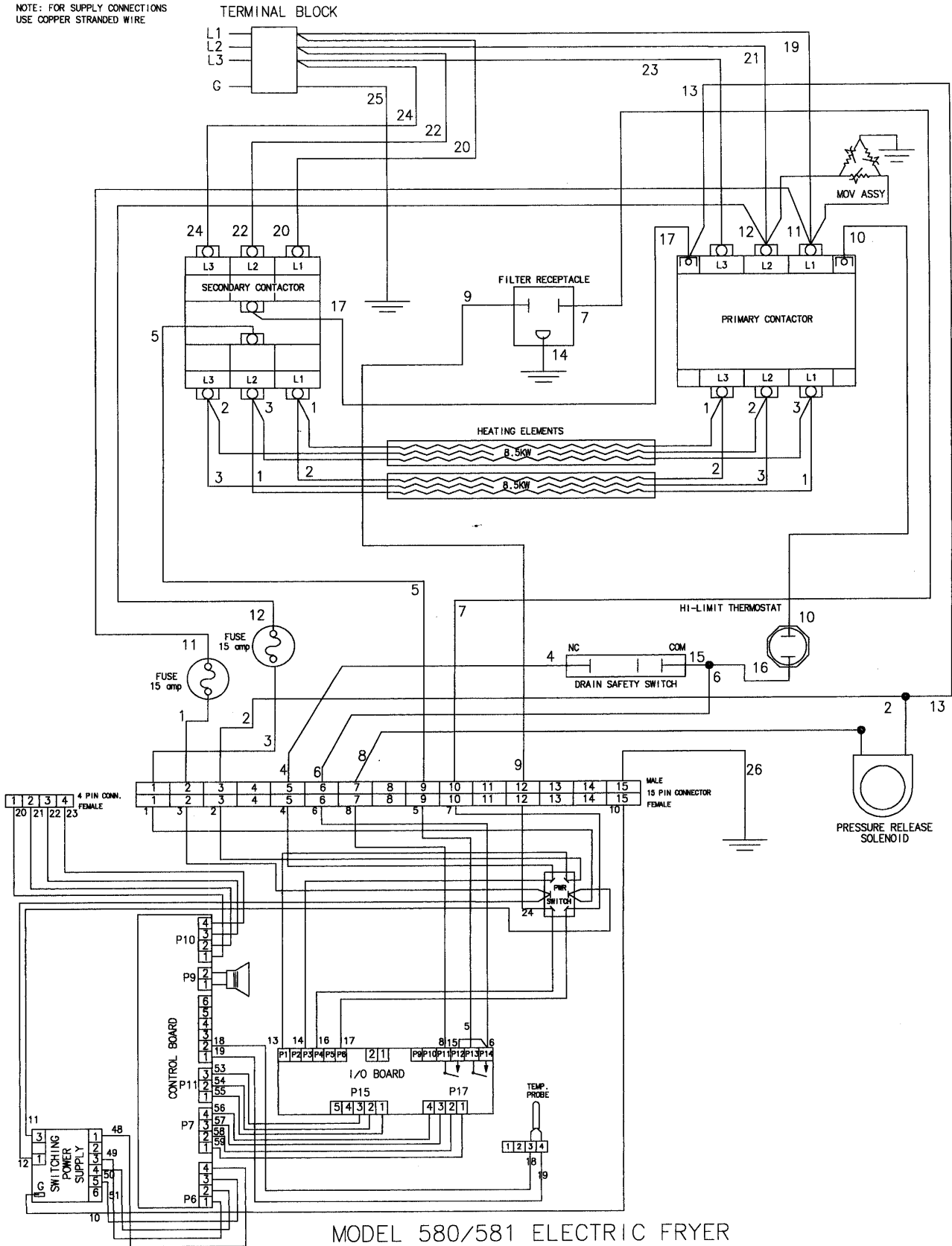

MODEL 580/581 ELECTRIC FRYER
240VAC 3PH 50Hz 3W +GRND

62122

Wiring Diagram for Units Built after Oct. 5, 2000

NOTE: FOR SUPPLY CONNECTIONS
USE COPPER STRANDED WIRE

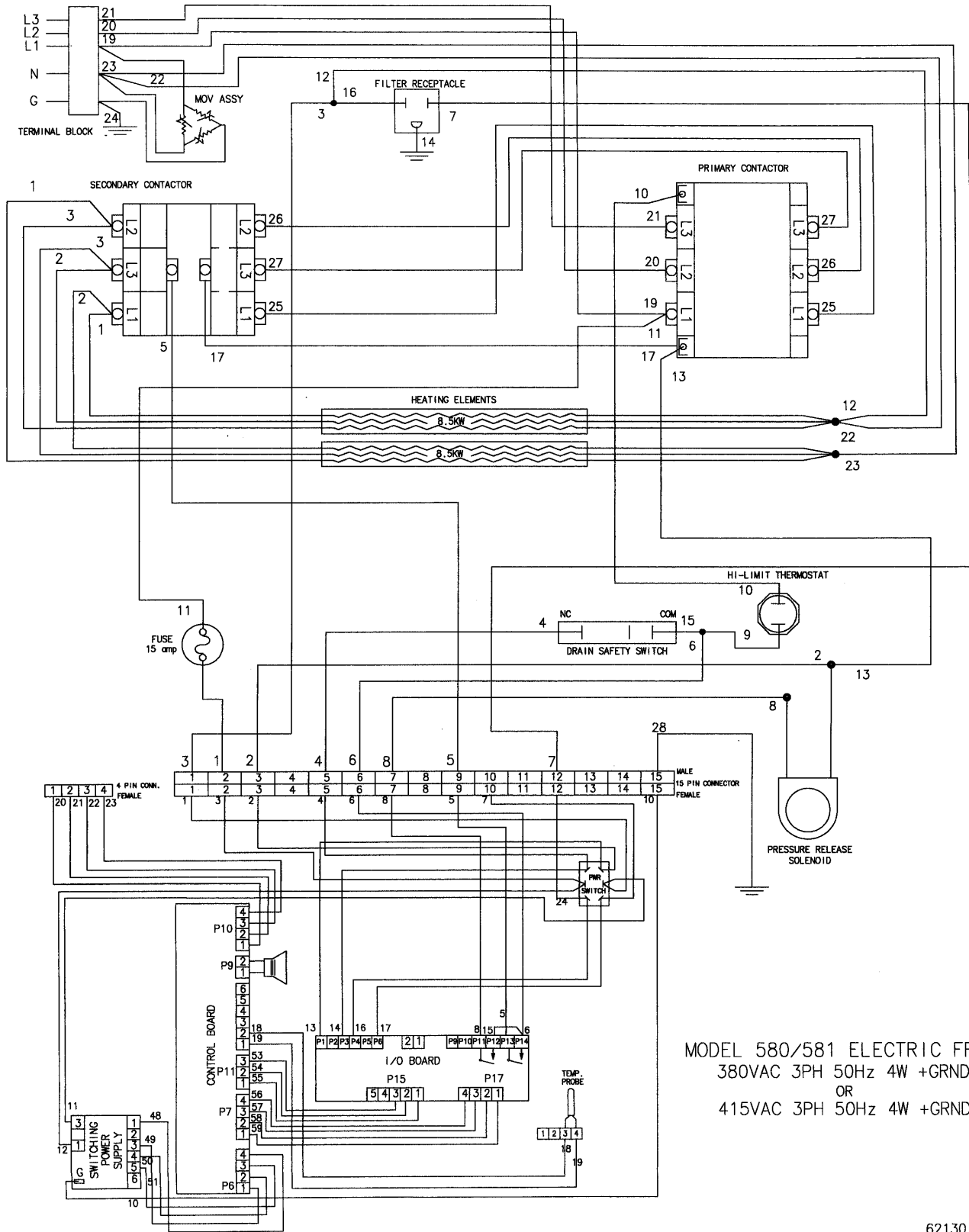

MODEL 580/581 ELECTRIC FRY
380VAC 3PH 50Hz 4W +GRND
OR
415VAC 3PH 50Hz 4W +GRND

62130

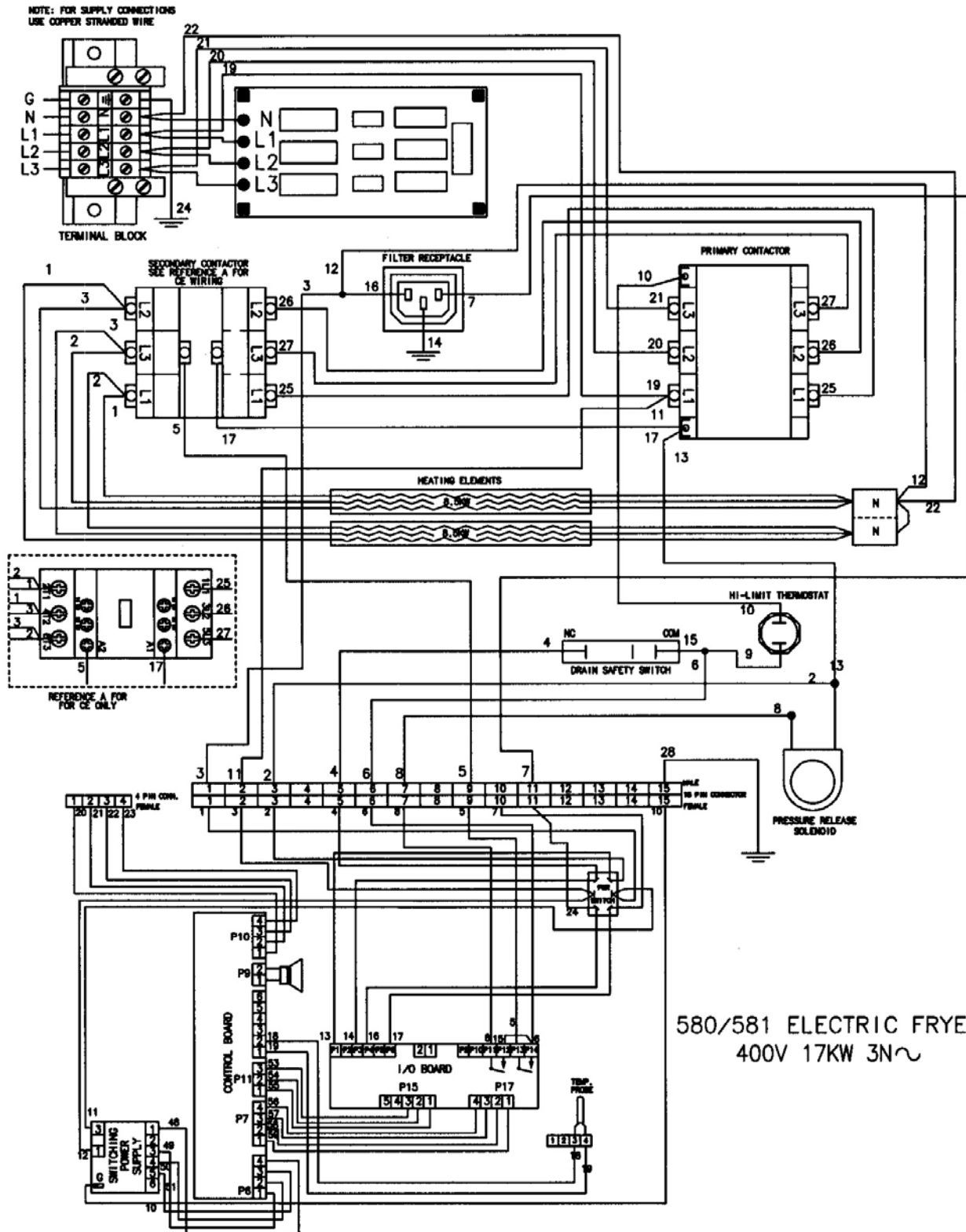

62131

Wiring Diagram for Units Built after Oct. 5, 2000

NOTE: FOR SUPPLY CONNECTIONS
USE COPPER STRANDED WIRE

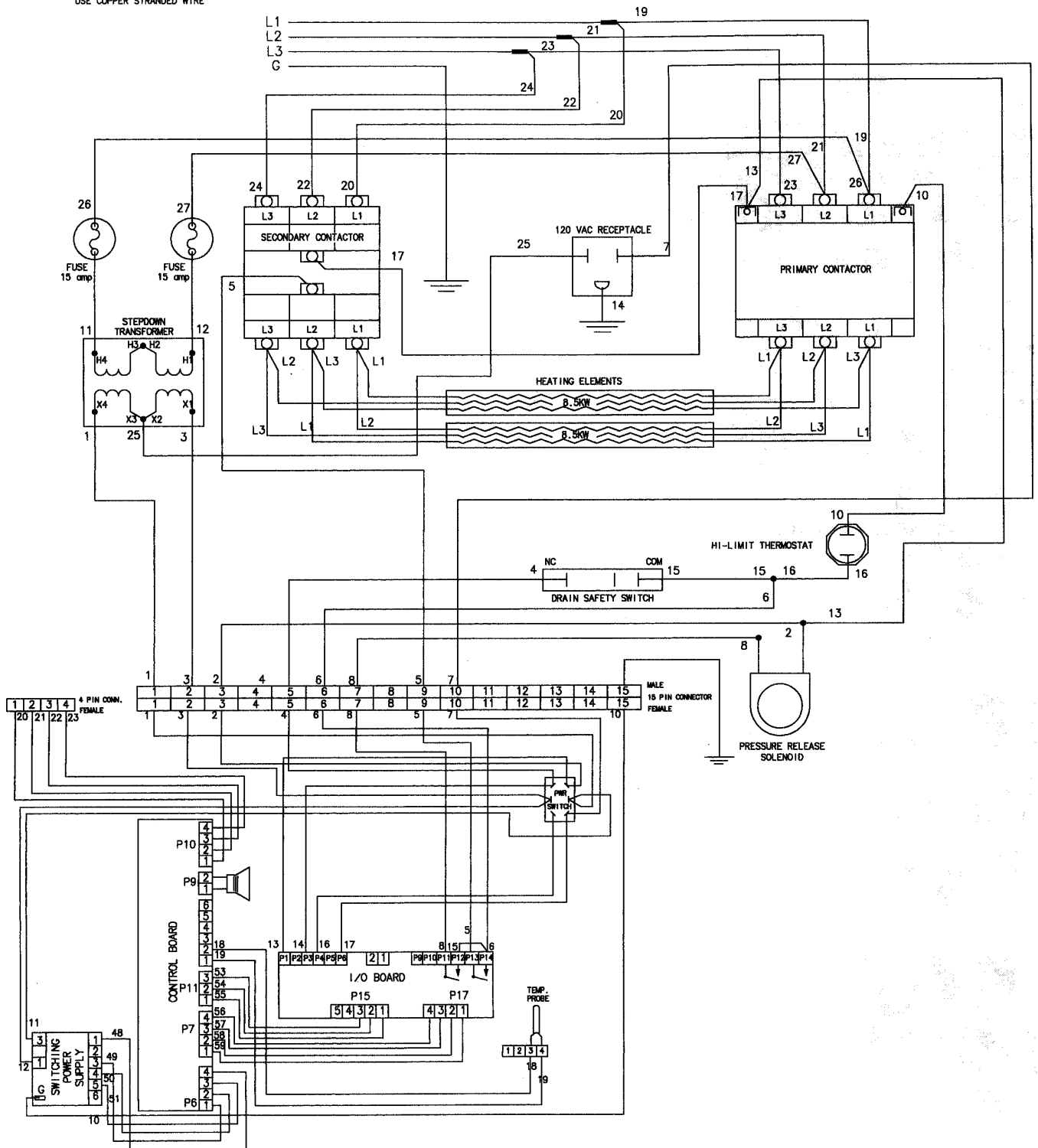

MODEL 581 ELECTRIC FRYER
17KW 480VAC
3PH 3WIRE W/GRND

21015