

# Hoshizaki America, Inc.

## Cubelet Icemaker / Dispenser

Model  
DT-400BAH-OS



“A Superior Degree  
of Reliability”

[www.hoshizaki.com](http://www.hoshizaki.com)

## SERVICE MANUAL



Number: 73155  
Issued: 5-8-2008

## IMPORTANT

Only qualified service technicians should attempt to install, service, or maintain this icemaker. No service or maintenance should be undertaken until the technician has thoroughly read this Service Manual. Failure to service and maintain the equipment in accordance with this manual may adversely affect safety, performance, and warranty coverage.

Hoshizaki provides this manual primarily to assist qualified service technicians in the service and maintenance of the icemaker.

Should the reader have any questions or concerns which have not been satisfactorily addressed, please call, write, or send an e-mail message to the Hoshizaki Technical Support Department for assistance.

HOSHIZAKI AMERICA, INC.  
618 Highway 74 South  
Peachtree City, GA 30269

Attn: Hoshizaki Technical Support Department

Phone: 1-800-233-1940 Technical Service  
(770) 487-2331

Fax: 1-800-843-1056  
(770) 487-3360

E-mail: techsupport@hoshizaki.com

Web Site: [www.hoshizaki.com](http://www.hoshizaki.com)

NOTE: To expedite assistance, all correspondence/communication MUST include the following information:

- Model Number \_\_\_\_\_
- Serial Number \_\_\_\_\_
- Complete and detailed explanation of the problem.

## IMPORTANT

This manual should be read carefully before the icemaker is serviced or maintenance operations are performed. Only qualified service technicians should install, service, and maintain the icemaker. Read the warnings contained in this booklet carefully as they give important information regarding safety. Please retain this booklet for any further reference that may be necessary.

## CONTENTS

I. Specifications .....	5
A. Icemaker .....	5
II. General Information.....	6
A. Construction.....	6
B. Ice Making Unit.....	7
C. Sequence of Operation.....	8
1. Fill Cycle.....	8
2. Ice Purge Cycle (60 seconds) .....	8
3. Freeze Cycle .....	8
4. Drain Cycle.....	8
5. Shutdown .....	8
D. Control Board .....	10
1. Control Board Layout .....	11
2. Features .....	12
3. Controls and Adjustments .....	13
4. Control Board Check Procedure .....	13
E. Float Switch .....	14
III. Technical Information .....	15
A. Water Circuit and Refrigeration Circuit .....	15
B. Wiring Diagram .....	16
1a. DT-400BAH-OS (auxiliary code: S-0).....	16
1b. DT-400BAH-OS (auxiliary code: T-0 and later).....	17
C. Sequence of Electrical Circuit – Ice Making (auxiliary code T-0 and later).....	18
1. Fill Cycle .....	18
2. Ice Purge Cycle .....	19
3. Freeze Cycle .....	20
4. 12 Hour Drain Cycle / Drain Switch.....	21
5. Shutdown .....	22
6. Low Water Safety .....	23
7. Safety Switch .....	24
8. High Pressure Switch .....	25
D. Sequence of Electrical Circuit – Dispensing .....	26
1. Continuous Dispense .....	26
2. Portion Dispense.....	27
E. Performance Data.....	28

IV. Service Diagnosis .....	29
A. Diagnostic Procedure .....	29
B. Ice Production Check.....	30
C. Diagnostic Charts .....	31
1. No Ice Production.....	31
2. Low Ice Production.....	34
3. Other .....	34
4. Dispensing.....	35
5. Opti Serve (OS) Sensors.....	37
V. Removal and Replacement of Components .....	38
A. Safety Switch .....	38
B. Service for Refrigerant Lines .....	39
1. Refrigerant Recovery .....	39
2. Brazing .....	39
3. Evacuation and Recharge (R-404A) .....	40
C. Removal of Refrigeration Tray.....	40
D. Removal and Replacement of Compressor.....	42
E. Removal and Replacement of Expansion Valve.....	43
F. Removal and Replacement of Evaporator Assembly Components .....	44
1. Upper Bearing Wear Check .....	45
2. Removal and Replacement of Extruding Head .....	45
3. Removal and Replacement of Auger .....	46
4. Removal and Replacement of Evaporator .....	47
5. Removal and Replacement of Mechanical Seal and Lower Housing .....	48
6. Removal and Replacement of Gear Motor.....	49
G. Removal and Replacement of Fan Motor.....	50
H. Removal and Replacement of Control or Dispensing Water Valve .....	50
I. Removal and Replacement of Drain Valve .....	51
J. Removal and Replacement of Dispensing System .....	52
1. Dispensing Auger and Agitator.....	52
2. Dispensing or Agitating Motor .....	52
VI. Cleaning and Maintenance .....	54
A. Cleaning and Sanitizing Instructions - Water System.....	54
1. Cleaning Solution .....	54
2. Cleaning Procedure.....	54
3. Sanitizing Solution.....	55
4. Sanitizing Procedure - Following Cleaning Procedure .....	55
B. Cleaning and Sanitizing Instructions - Dispensing Components .....	57
1. Cleaning Solution .....	57
2. Sanitizing Solution.....	57
3. Dispensing Components Cleaning and Sanitizing Procedure.....	57
C. Maintenance .....	59
D. Preparing the Icemaker for Long Storage .....	60

# I. Specifications

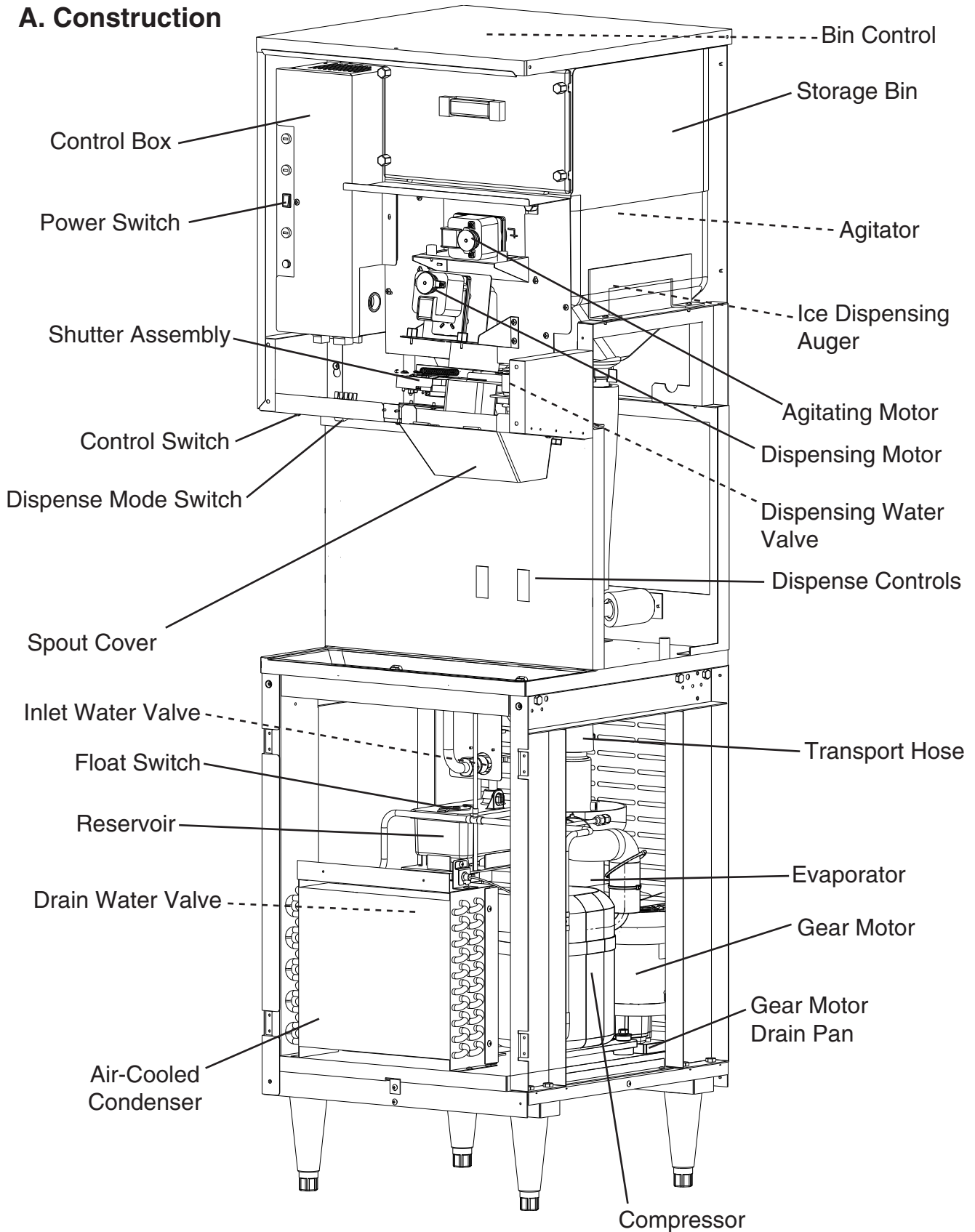
## A. Ice maker

AC SUPPLY VOLTAGE	115/60/1		
AMPERAGE	11.5 A (AT 104°F / WT 80°F)		
MAXIMUM FUSE SIZE	N/A		
MINIMUM CIRCUIT AMPACITY	N/A		
APPROXIMATE ICE PRODUCTION PER 24 HR.	Ambient Temp.(°F)	WATER TEMP. (°F)	
lbs./day ( kg/day )		50	70
Reference without *marks	70	* 409 (186)	388 (176)
	80	354 (160)	338 (153)
	90	308 (140)	* 296 (134)
	100	268 (122)	* 242 (110)
SHAPE OF ICE	Cubelet		
ICE QUALITY	Approx. 80%, Ice (90/70°F, Conductivity 200 µs/cm)		
APPROXIMATE STORAGE CAPACITY	40 lbs		
ELECTRIC & WATER CONSUMPTION	90/70°F	70/50°F	
ELECTRIC W (kWH/100 lbs.)	935 (7.6)	885 (5.2)	
POTABLE WATER	36 (12)	49 (12)	
gal./24HR (gal./100 lbs.)			
EXTERIOR DIMENSIONS (WxDxH,w/LEGS)	21" x 22-1/2" x 72-1/2" (534 x 571 x 1841mm)		
EXTERIOR FINISH	Stainless Steel, Galvanized Steel (Rear, Bottom)		
WEIGHT	Net 283 lbs. ( 128 kg ), Shipping 308 lbs. ( 140 kg )		
CONNECTIONS - ELECTRIC	Cord Connection		
- WATER SUPPLY	Inlet 1/2" FPT		
- DRAIN	Outlet 3/4" FPT (x 2)		
ICE MAKING SYSTEM	Auger type		
HARVESTING SYSTEM	Direct Driven Auger ( 1/4 HP Gear Motor )		
ICE MAKING WATER CONTROL	Float Switch		
COOLING WATER CONTROL	N/A		
DISPENSER CONTROL SYSTEM	Photoelectric Sensor ( Infrared )		
BIN CONTROL SYSTEM	Mechanical Bin Control ( Proximity Sw. )		
COMPRESSOR	Hermetic, Model RS43-C2E-CAA		
CONDENSER	Air-cooled, Fin and Tube Type		
EVAPORATOR	Copper Tube on Cylinder		
REFRIGERANT CONTROL	Thermostatic Expansion Valve		
REFRIGERANT CHARGE	R-404A, 1lb 1oz (480 g)		
DESIGN PRESSURE	High 427 PSIG, Low 230 PSIG		
P.C. BOARD CIRCUIT PROTECTION	High Voltage Cut-off Relay		
COMPRESSOR PROTECTION	Auto-reset Overload Protector		
GEAR MOTOR PROTECTION	Fuse (2A)		
REFRIGERANT CIRCUIT PROTECTION	Auto-reset High Pressure Control Switch		
LOW WATER PROTECTION	Float Switch and Timer		
ACCESSORIES - SUPPLIED	Spare Fuse		
	Legs		
OPERATING CONDITIONS	VOLTAGE RANGE	104 - 127 V	
	AMBIENT TEMP.	45 - 100° F	
	WATER SUPPLY TEMP.	45 - 90° F	
	WATER SUPPLY PRESSURE	10 - 113 PSIG	

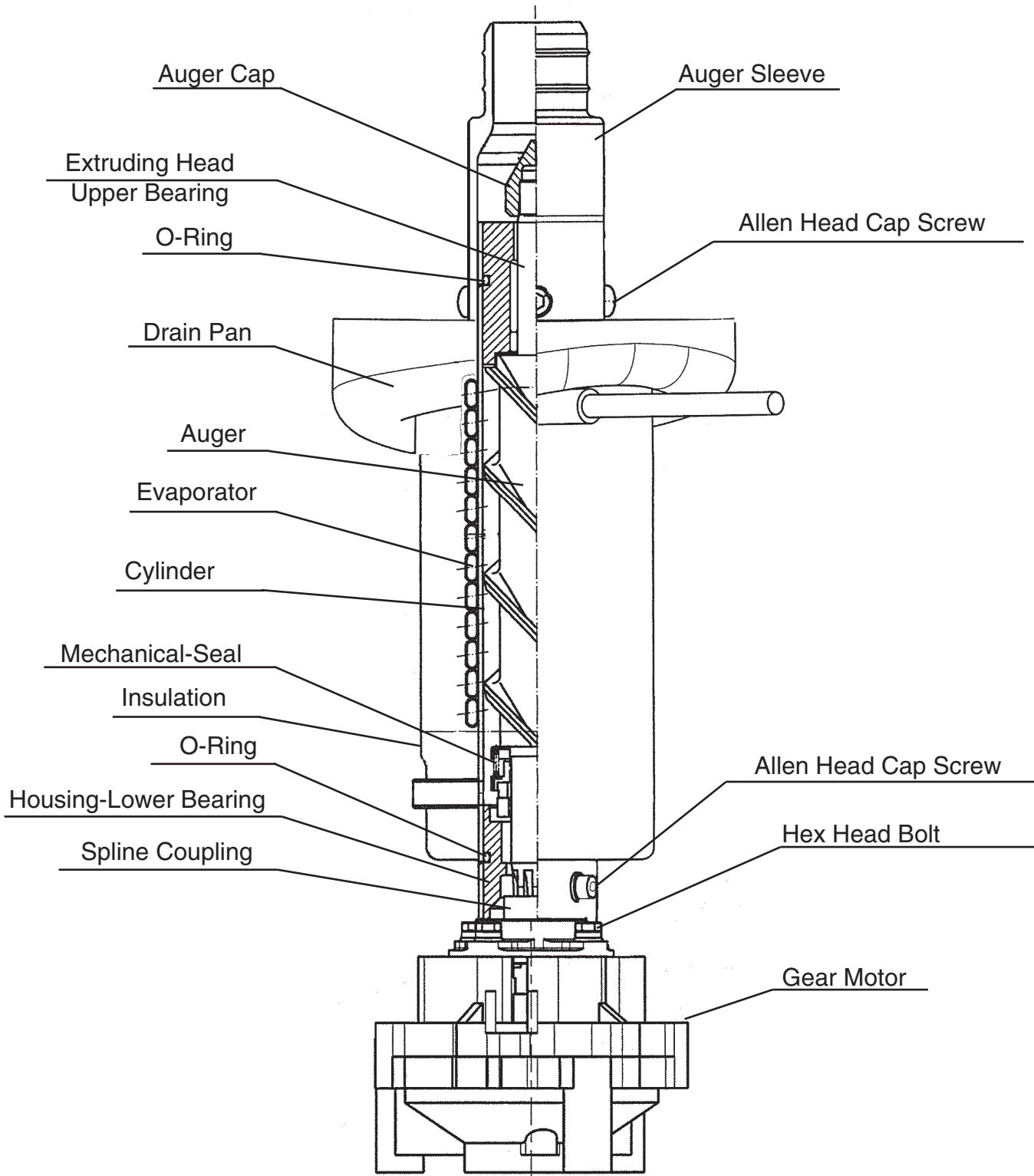
Note: We reserve the right to make changes in specifications and design without prior notice.

## II. General Information

### A. Construction



## B. Ice Making Unit



## C. Sequence of Operation

The steps in the sequence are as outlined below. When power is supplied, the power switch is in the "ON" position, and the control switch is in the "ICE" position, the "POWER" LED on the control board comes on.

### 1. Fill Cycle

WV opens and the reservoir fills with water until UF/S closes. Note: GM will not start unless UF/S is closed. For details, see "IV. Service Diagnosis".

### 2. Ice Purge Cycle (60 seconds)

"GM" LED is on. WCR energizes, closing the low water safety circuit and de-energizing the WV. GM and GMPR energize. GM runs for 60 seconds to clear any ice from the evaporator.

### 3. Freeze Cycle

"COMP", "GM" LEDs are on. Comp and FMS energize. As the water in the evaporator cools, ice starts forming within 4 to 6 minutes. This time frame depends on the inlet water and ambient temperature conditions. UF/S and LF/S operate WV as needed to continue the ice making process. This continues until BC shuts the icemaker down or power is turned off to the icemaker.

### 4. Drain Cycle

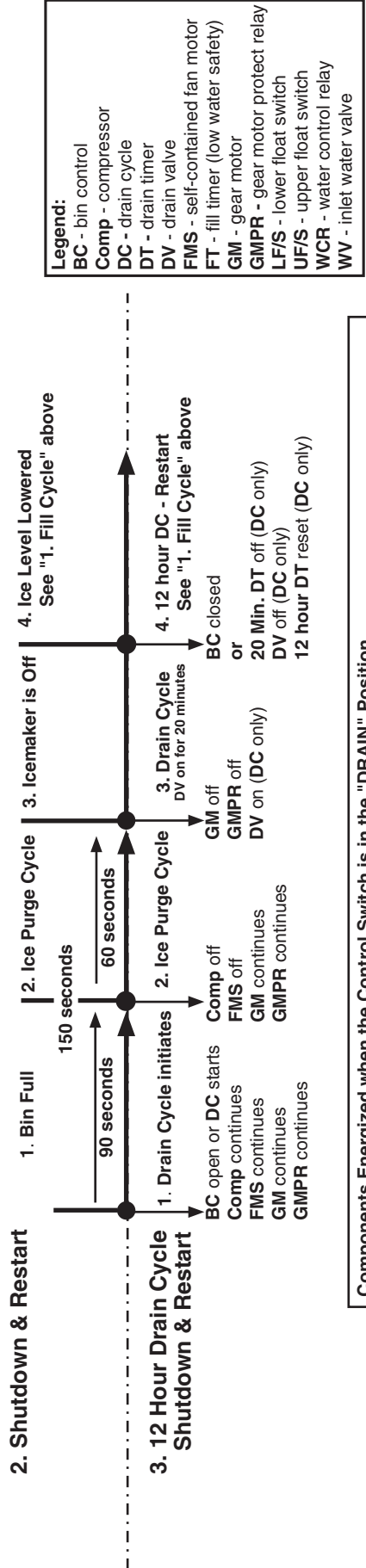
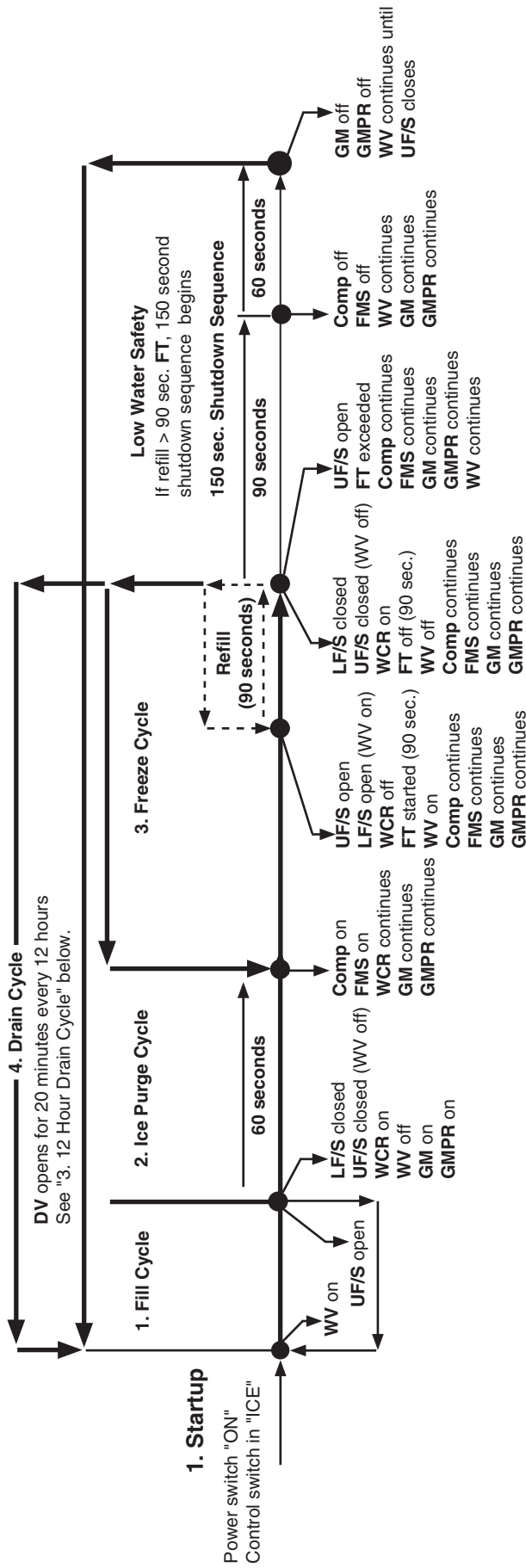
12 hour DT activates, "FLUSH" LED is on after 150 second shutdown sequence. Comp and FMS de-energize 90 seconds after the 12 hour DT activates, GMPR and GM de-energize 60 seconds later. DV then energizes and remains energized for 20 minutes.

### 5. Shutdown

BC is activated and a 150 second shutdown sequence begins. After BC has been open for 90 seconds, Comp and FMS de-energize, AM energizes for 0.6 seconds, and 60 seconds later GM de-energizes.

Legend: **AM**—agitating motor; **BC**—bin control; **Comp**—compressor; **DT**—drain timer; **FMS**—self-contained fan motor; **GM**—gear motor; **GMPR**—gear motor protect relay; **LF/S**—lower float switch; **UF/S**—upper float switch; **WCR**—water control relay; **WV**—inlet water valve

# DT-400BAH-OS Sequence Flow Chart and Component Operation



**Legend:**

- BC - bin control
- Comp - compressor
- DC - drain cycle
- DT - drain timer
- DV - drain valve
- FMS - self-contained fan motor
- FT - fill timer (low water safety)
- GM - gear motor
- GMPR - gear motor protect relay
- LF/S - lower float switch
- UF/S - upper float switch
- WCR - water control relay
- WV - inlet water valve

**Components Energized when the Control Switch is in the "DRAIN" Position**  
The "DRAIN" position on the control switch is used when cleaning and sanitizing the unit. This allows cleaner and sanitizer to drain from the reservoir and evaporator assembly. When switching to the "DRAIN" position during the freeze cycle, the drain valve does not energize until the 150 second shutdown sequence terminates (2. Shutdown & Restart).  
Note: To bypass the 150 second shutdown sequence, move the power switch to the "OFF" position, place the control switch in the "DRAIN" position, then move the power switch back to the "ON" position.

## D. Control Board

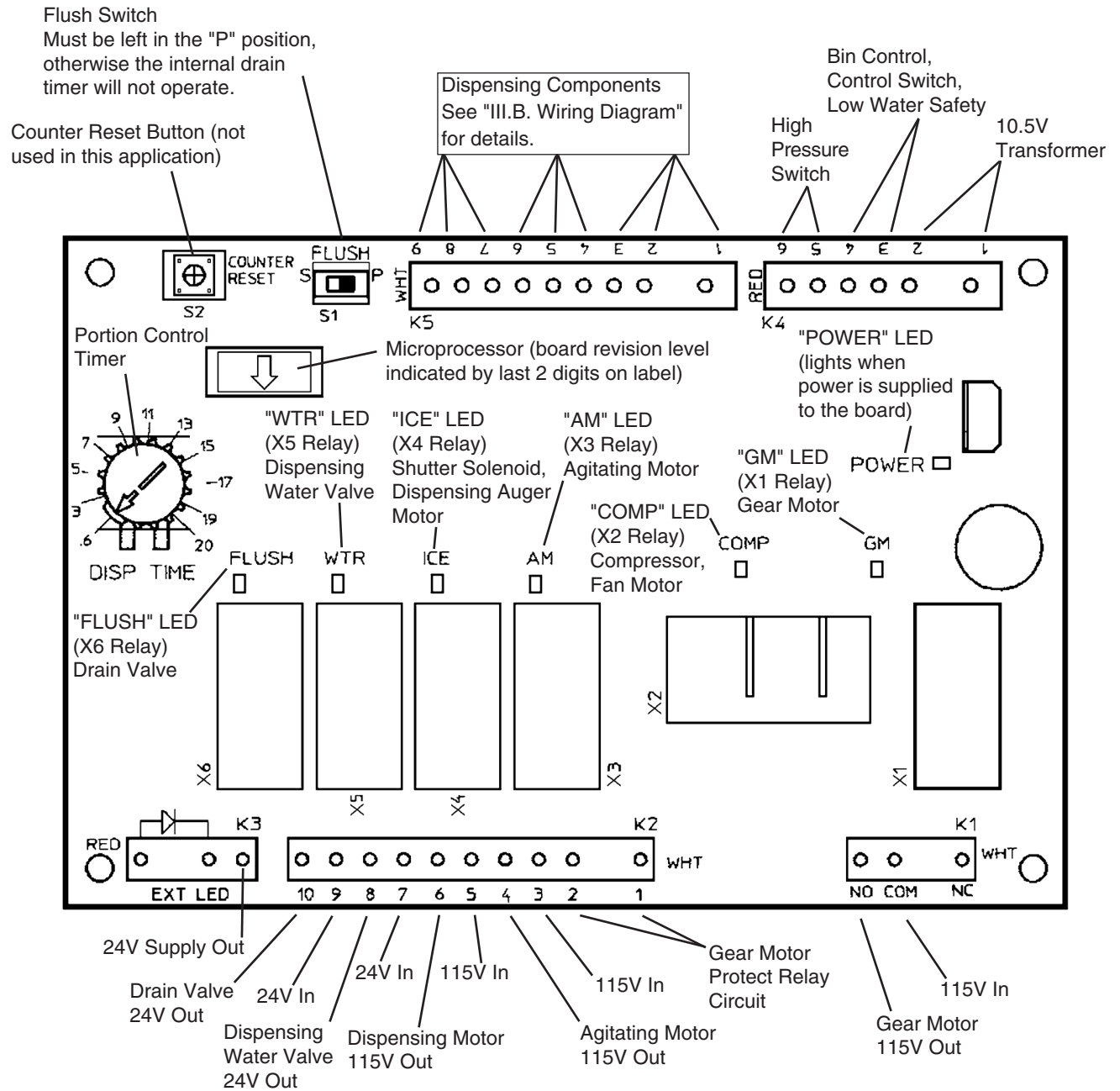
- A Hoshizaki exclusive solid-state control board is employed in DT-400BAH-OS Cubelet Ice maker / Dispenser.
- All models are pretested and factory-adjusted.

### CAUTION

1. Fragile, handle very carefully.
2. The control board contains integrated circuits, which are susceptible to failure due to static discharge. It is especially important to touch the metal part of the unit before handling or replacing the board.
3. Do not touch the electronic devices on the control board or the back of the control board to prevent damage to the control board.
4. Do not change wiring and connections. Especially, never misconnect terminals.
5. Always replace the whole control board if it goes bad.
6. Do not short out power supply to test for voltage.

# 1. Control Board Layout

## DT-400BAH-OS



Control Board	
Part Number	2A2649-01

## 2. Features

The control board provides the following safeguards:

- Provides component protection during low water supply.
- Purges remaining ice in the evaporator at startup and shutdown.
- Provides short cycle protection for the compressor.

### a) LED Lights

The "POWER" LED indicates control voltage and will remain on unless a control voltage problem occurs. An LED illuminates for each relay as it is energized. For more information, see "II.C. Sequence of Operation."

Icemaking				
Cycle (Relay)	LED	Energized Components	Time LEDs are On	Frequency LEDs are On
Fill	POWER only	WV	N/A	As Needed
Ice Purge (X1)	GM	GM	60 seconds	N/A
Freeze (X1, X2)	GM, COMP	GM, Comp, FMS	N/A	N/A
Drain Valve (X6)	FLUSH	DV	20 Minutes	Every 12 Hours

Dispensing				
Relay	LED	Energized Component	Time LEDs are On	Frequency LEDs are On
Ice Dispense (X4)	ICE	IDM	60 seconds maximum	N/A
Agitating Motor (X3)	AM	AM	.6 seconds	Every 12 seconds of accumulative dispense time
Water Dispense (X5)	WTR	WTR	N/A	N/A

Legend: **AM**—agitating motor, **Comp**—compressor; **DV**—drain valve; **FMS**—self-contained fan motor; **GM**—gear motor; **IDM**—ice dispensing motor, shutter solenoid; **WTR**—dispensing water valve; **WV**—inlet water valve

### 3. Controls and Adjustments

#### a) Portion Control

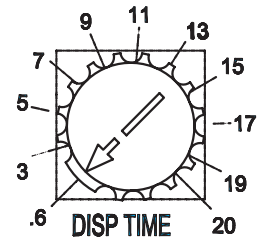
When the change switch (dispense mode switch) is placed in the "PORTION" position, a variable resistor (located on the control board) controls the ice dispense time.

The figures on the label indicate dispensing time (sec.). When shipped, the portion control is set at the minimum dispensing time (0.6 sec.).

DT-400BAH-OS . . . . . Approximately 0.72 oz.

Amount of ice dispensed per second.

DT-400BAH-OS . . . . . Approximately 1.2 oz.



#### 4. Control Board Check Procedure

Before replacing a control board that does not show a visible defect and that you suspect is bad, always conduct the following check procedure. This procedure will help you verify your diagnosis.

##### a) Power Supply

1. Move the control switch to the "ICE" position. The "POWER" LED should come on. If the "POWER" LED is off, check that the power supply is on, the power switch is in the "ON" position, the safety switch is not engaged, and the control switch is in the "ICE" position. Check the transformer 10.5V secondary circuit and fuse. If the 10.5V secondary circuit (K4 pins 1 and 2) has proper voltage and the "POWER" LED is off, the control board is bad and should be replaced.

If the secondary circuit does not have proper voltage, see "IV.C.1.[1] The icemaker will not start (Fill Cycle)" for further details.

##### b) Ice Making Components

1. Confirm the reservoir is full of water. If no water is in the reservoir, make sure that the control switch is not in the "DRAIN" position and that the unit is not in the 12 hour drain cycle. Also check the water supply line, water shutoff valve, and water filters. In the fill cycle, the "POWER" LED will be the only LED lit on the control board. If no water is filling the reservoir, check for 24V at connector K2 terminal 7 to neutral and connector K3 (DBU) to neutral. If there is 24V at connector K2 terminal 7 to neutral and no voltage at K3 (DBU) to neutral, the control board is bad and should be replaced. See "IV.C.1.[1] The icemaker will not start (Fill Cycle)" for further details.
2. When the reservoir is full, the "GM" LED comes on and the gear motor starts. If the "GM" LED does not come on or the gear motor does not start, check that the following safety circuits are closed: a) high pressure switch (connector K4 terminals 5 and 6), b) low water safety/bin control/ice making switch circuit (connector K4 terminals 3 and 4). Next, check for 115/120V at connector K1 "COM" and K1 "NO" on the control board to neutral. If the "GM" LED is on and there is voltage at connector K1 "COM" to neutral and no voltage at K1 "NO" to neutral, the control board is bad and should be replaced. See wiring diagram "III.C.2. Ice Purge Cycle" for further details.

3. 60 seconds after the "GM" LED comes on, the "COMP" LED comes on, and the compressor and fan motor start. If the "COMP" LED does not come on 60 seconds after the gear motor starts, check that the gear motor protect relay contacts (connector K2 terminals 1 and 2) have closed. If the "COMP" LED is on and the compressor and fan motor did not start, check for 115/120V at X2 (LBU) and X2 (BR) on the control board to neutral. If the "COMP" LED is on and there is voltage at X2 (BR) to neutral and no voltage at X2 (LBU) to neutral, the control board is bad and should be replaced. See wiring diagram "III.C.3. Freeze Cycle" for further details.

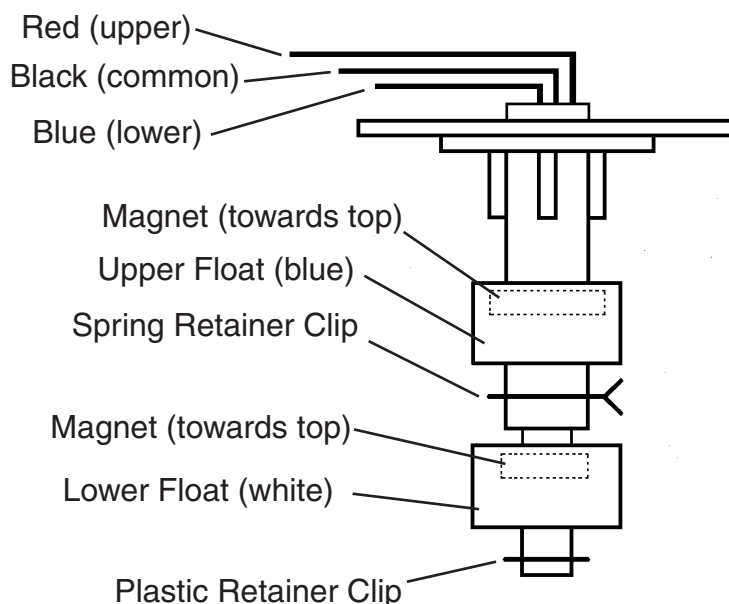
**c) Dispensing Components**

See "IV.C.5. Opti Serve (OS) Sensors."

**E. Float Switch**

Depending on local water conditions, scale may build up on the float switch. Scale on the switch can cause the floats to stick. In this case, the float switch should be cleaned and checked.

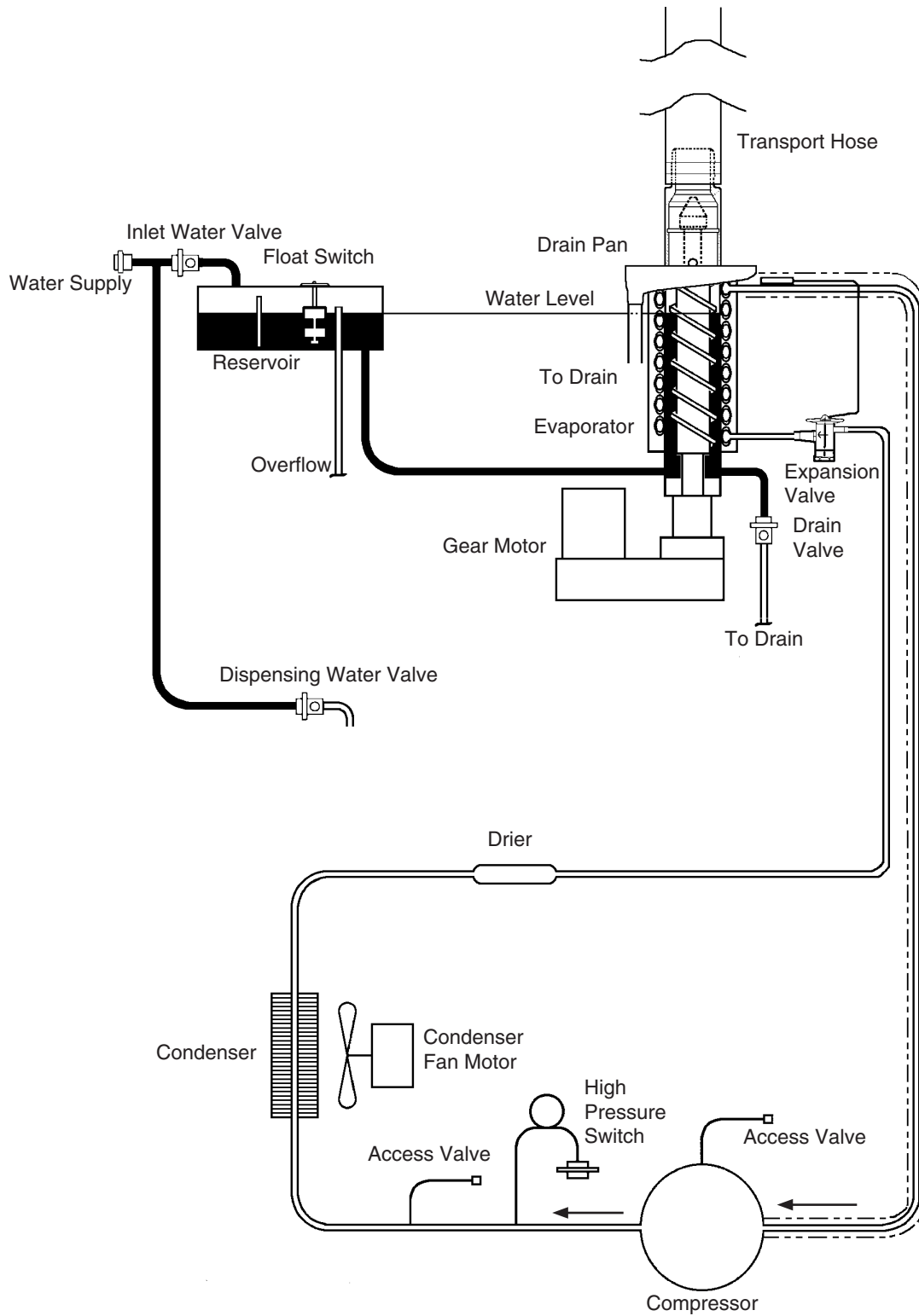
First, remove the switch from the water tank. Soak the switch assembly in ice machine cleaner. While not necessary, the floats can be removed from the shaft during cleaning. If you remove them, note that the blue float is on top. The floats must be installed with the magnets inside them towards the top of the switch. Installing the floats upside down will affect the timing of the float switch operation. Once clean, rinse and wipe the cleaner off. Next, check the switch with an ohm meter. This float switch has three wires (the black wire is common) and two separate switches. Check the upper switch by ohming out the black and red wires. When the float is up, the switch should be closed. Check the lower switch by ohming out the black and blue wires in the same manner. If either switch fails, the assembly should be replaced.



### III. Technical Information

#### A. Water Circuit and Refrigeration Circuit

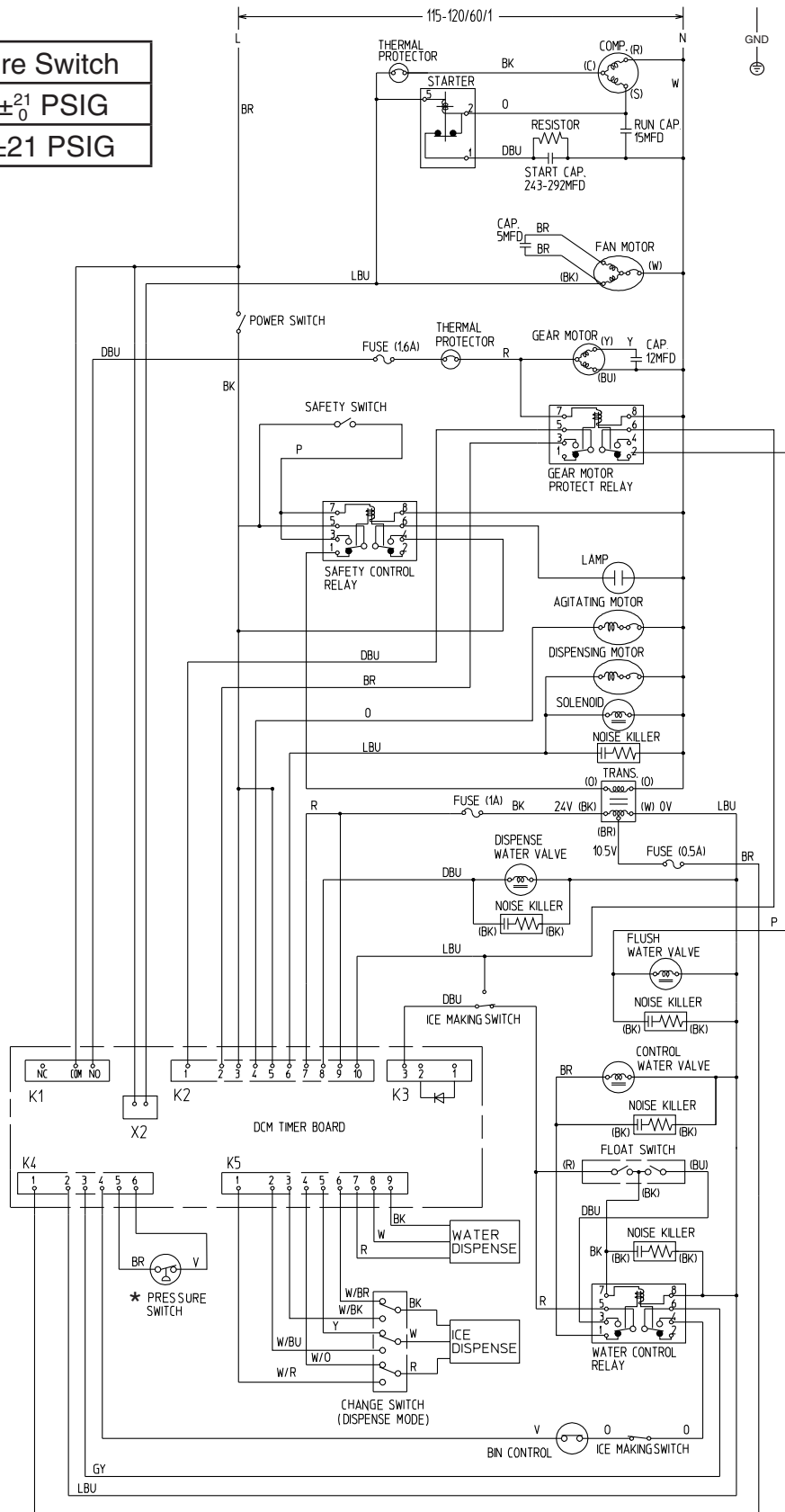
##### 1. DT-400BAH-OS



# B. Wiring Diagram

## 1a. DT-400BAH-OS (auxiliary code: S-0)

* High Pressure Switch	
Cut-out	412± <sup>21</sup> <sub>0</sub> PSIG
Cut-in	327±21 PSIG

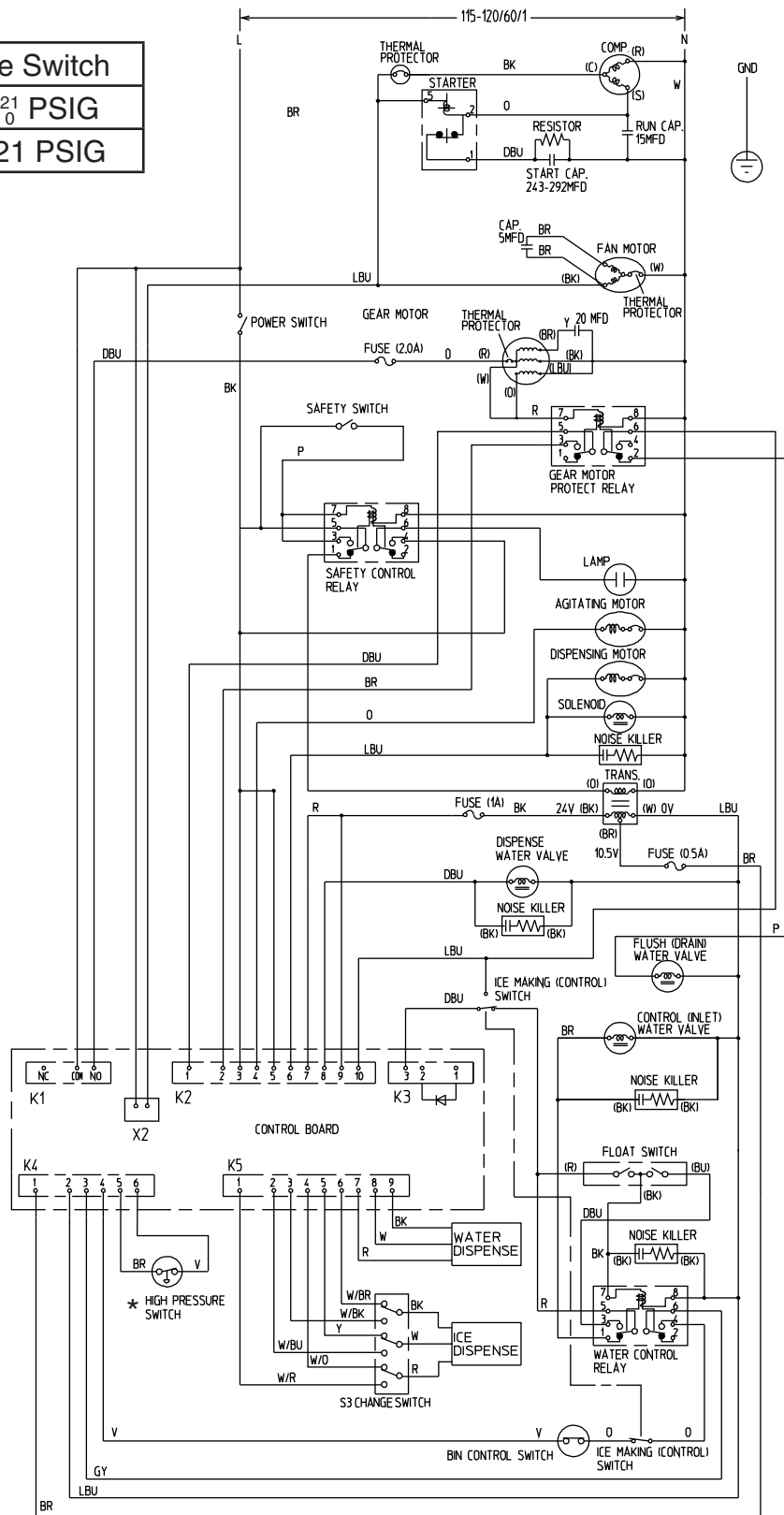


### WIRE COLOR CODE

BK	BLACK
BR	BROWN
BU	BLUE
DBU	DARK BLUE
GY	GRAY
LBU	LIGHT BLUE
O	ORANGE
P	PINK
R	RED
V	VIOLET
W	WHITE
Y	YELLOW
W/BK	WHITE/BLACK
W/BR	WHITE/BROWN
W/BU	WHITE/BLUE
W/O	WHITE/ORANGE
W/R	WHITE/RED

# 1b. DT-400BAH-OS (auxiliary code: T-0 and later)

* High Pressure Switch	
Cut-out	412± <sup>21</sup> <sub>0</sub> PSIG
Cut-in	327±21 PSIG



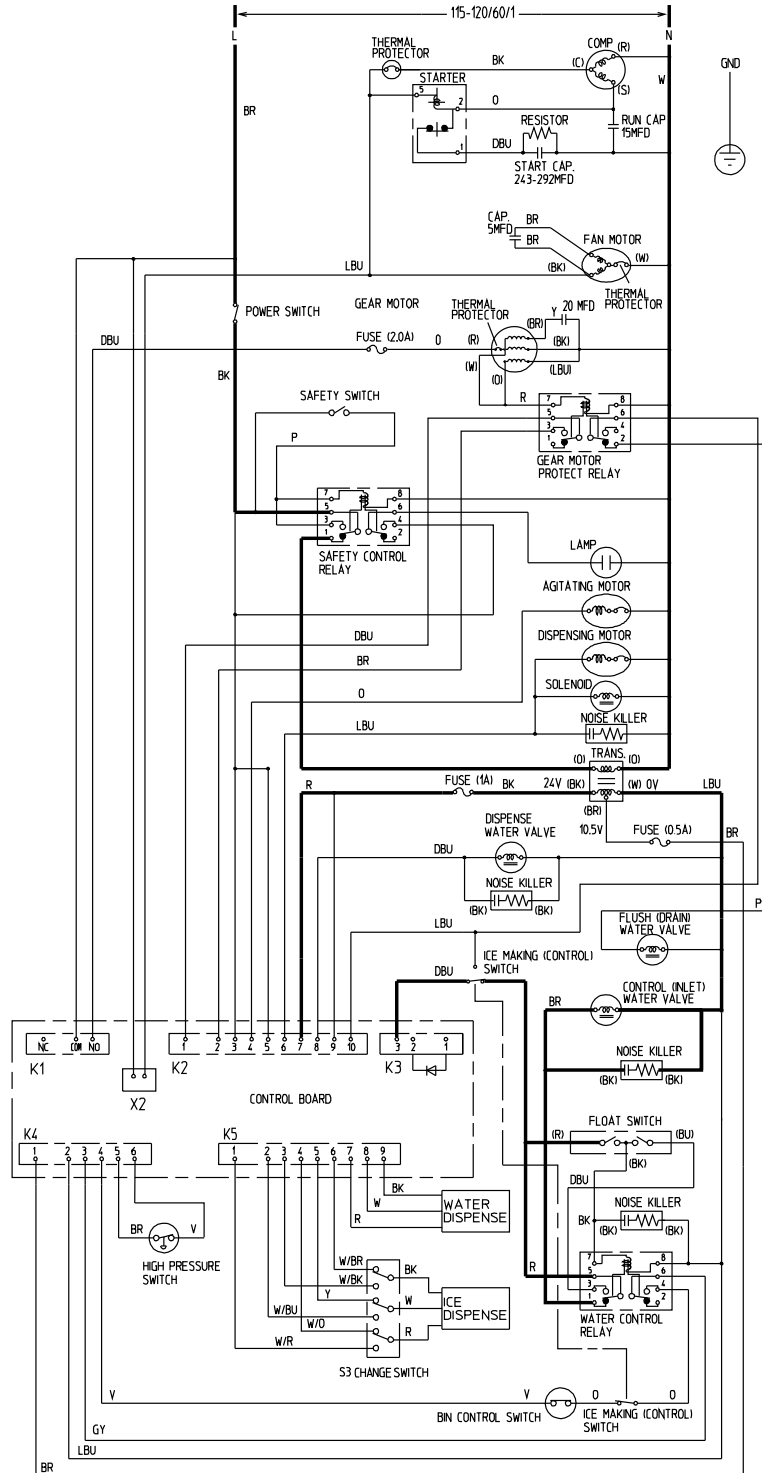
### WIRE COLOR CODE

BK	BLACK
BR	BROWN
BU	BLUE
DBU	DARK BLUE
GY	GRAY
LBU	LIGHT BLUE
O	ORANGE
P	PINK
R	RED
V	VIOLET
W	WHITE
Y	YELLOW
W/BK	WHITE/BLACK
W/BR	WHITE/BROWN
W/BU	WHITE/BLUE
W/O	WHITE/ORANGE
W/R	WHITE/RED

# C. Sequence of Electrical Circuit – Ice Making (auxiliary code T-0 and later)

## 1. Fill Cycle

With the power switch in the "ON" position and the control switch in the "ICE" position, the inlet water valve energizes and the reservoir fills with water until the upper float switch closes.

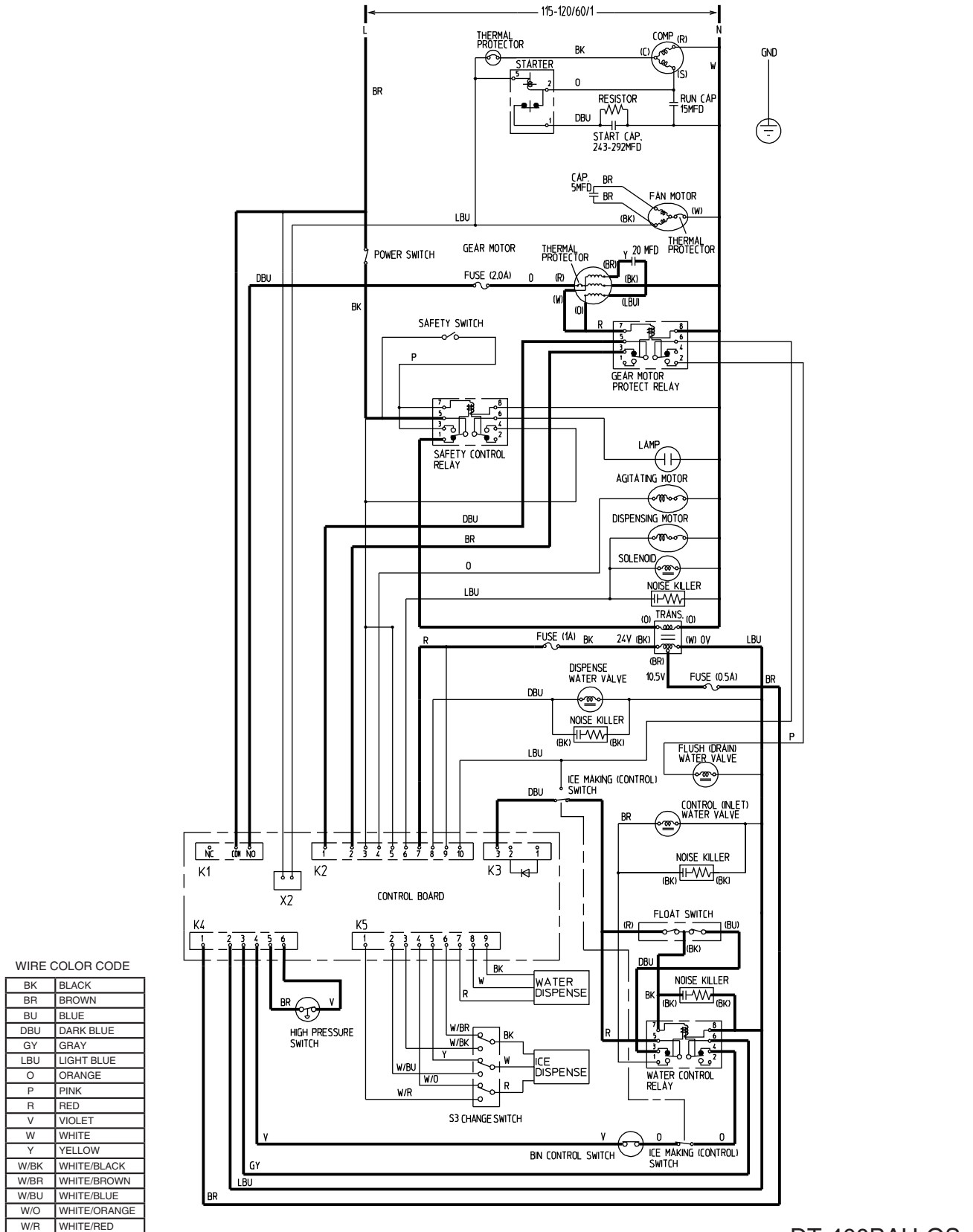


### WIRE COLOR CODE

BK	BLACK
BR	BROWN
BU	BLUE
DBU	DARK BLUE
GY	GRAY
LBU	LIGHT BLUE
O	ORANGE
P	PINK
R	RED
V	VIOLET
W	WHITE
Y	YELLOW
W/BK	WHITE/BLACK
W/BR	WHITE/BROWN
W/BU	WHITE/BLUE
W/O	WHITE/ORANGE
W/R	WHITE/RED

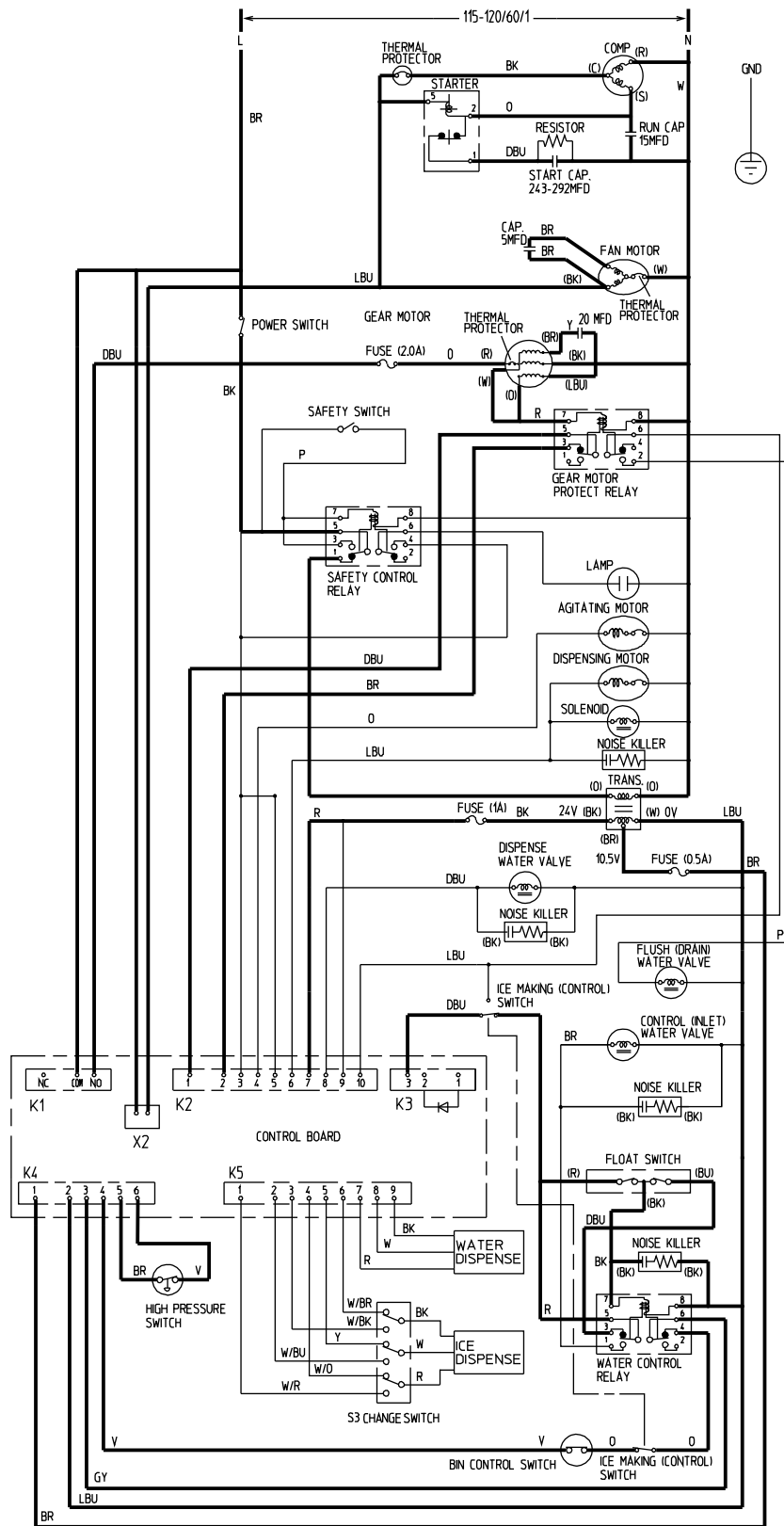
## 2. Ice Purge Cycle

Upper float switch closes, water control relay energizes, inlet water valve closes, gear motor starts, gear motor protect relay energizes.



### 3. Freeze Cycle

Compressor and fan motor start 60 seconds after gear motor starts.

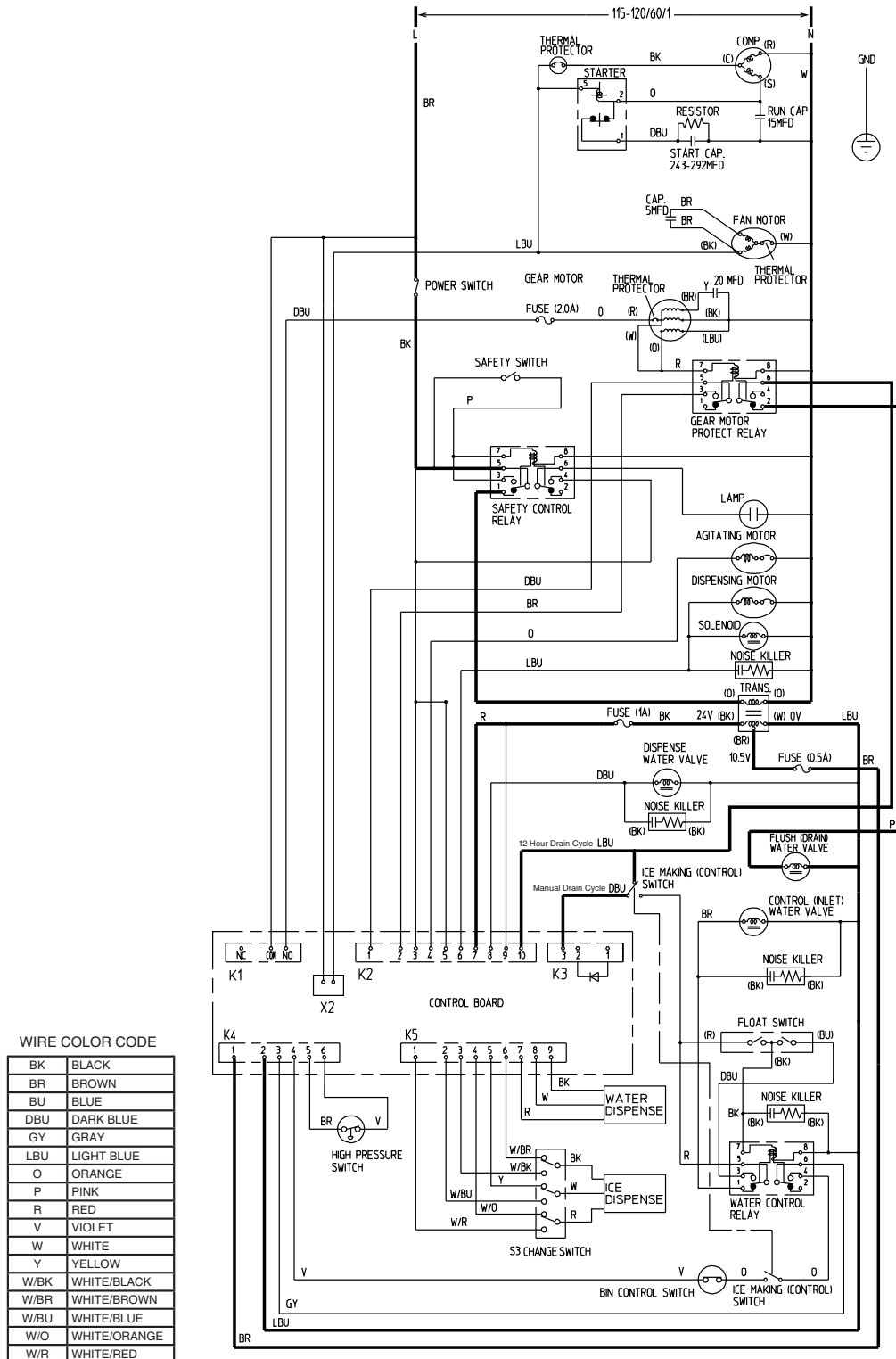


WIRE COLOR CODE

BK	BLACK
BR	BROWN
BU	BLUE
DBU	DARK BLUE
GY	GRAY
LBU	LIGHT BLUE
O	ORANGE
P	PINK
R	RED
V	VIOLET
W	WHITE
Y	YELLOW
W/BK	WHITE/BLACK
W/BR	WHITE/BROWN
W/BU	WHITE/BLUE
W/O	WHITE/ORANGE
W/R	WHITE/RED

#### 4. 12 Hour Drain Cycle / Drain Switch

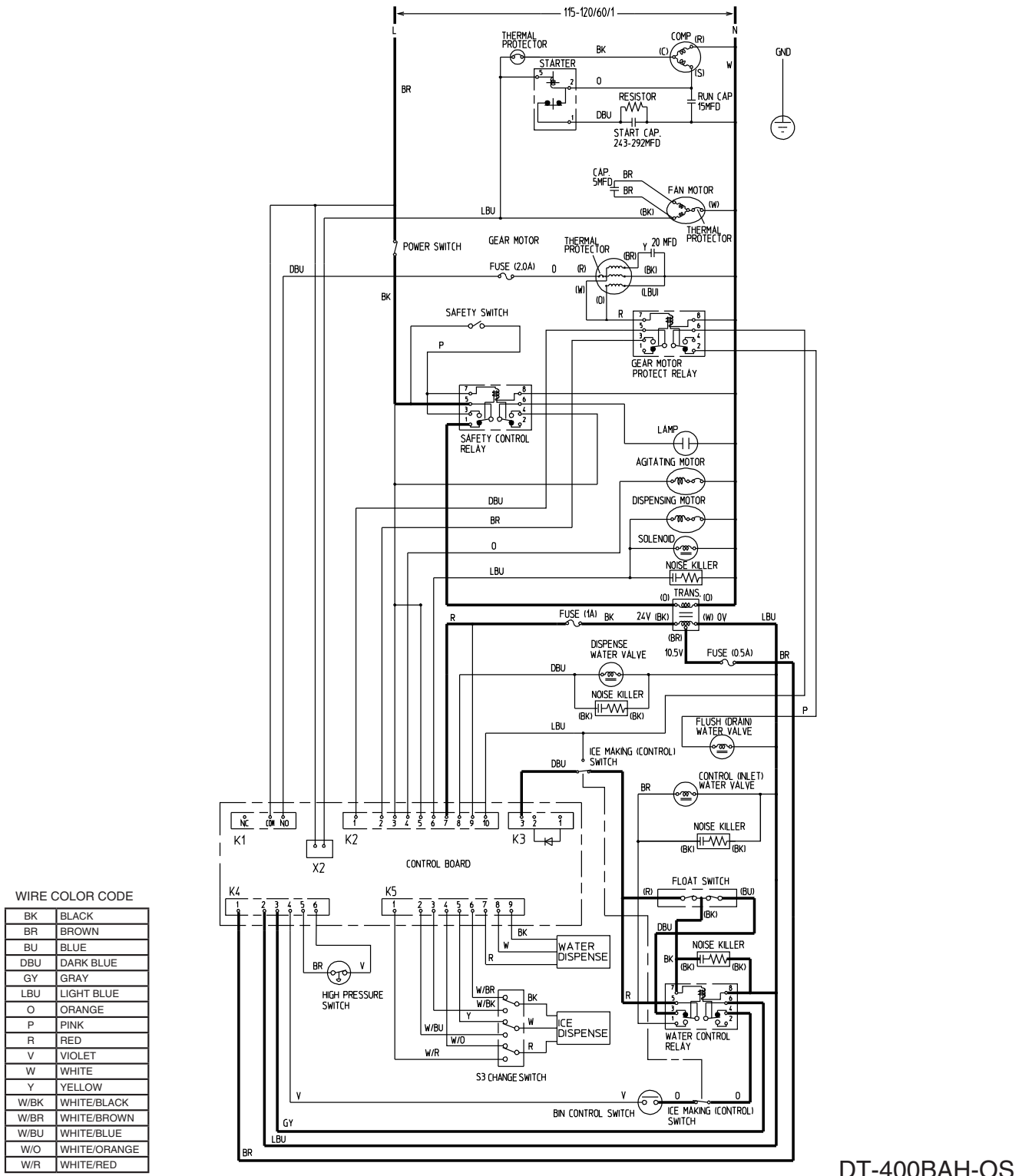
12 hour timer initiates cycle or the control switch is moved to the "DRAIN" position. 90 seconds after initiation, the compressor and condenser fan motor stop, 60 seconds later the gear motor stops. Once the gear motor protect relay de-energizes, the drain water valve opens. In the 12 hour drain cycle, the drain water valve remains open for 20 minutes. When the drain cycle is initiated manually using the control switch, the drain valve remains open until the control switch is moved to the "ICE" position.



DT-400BAH-OS

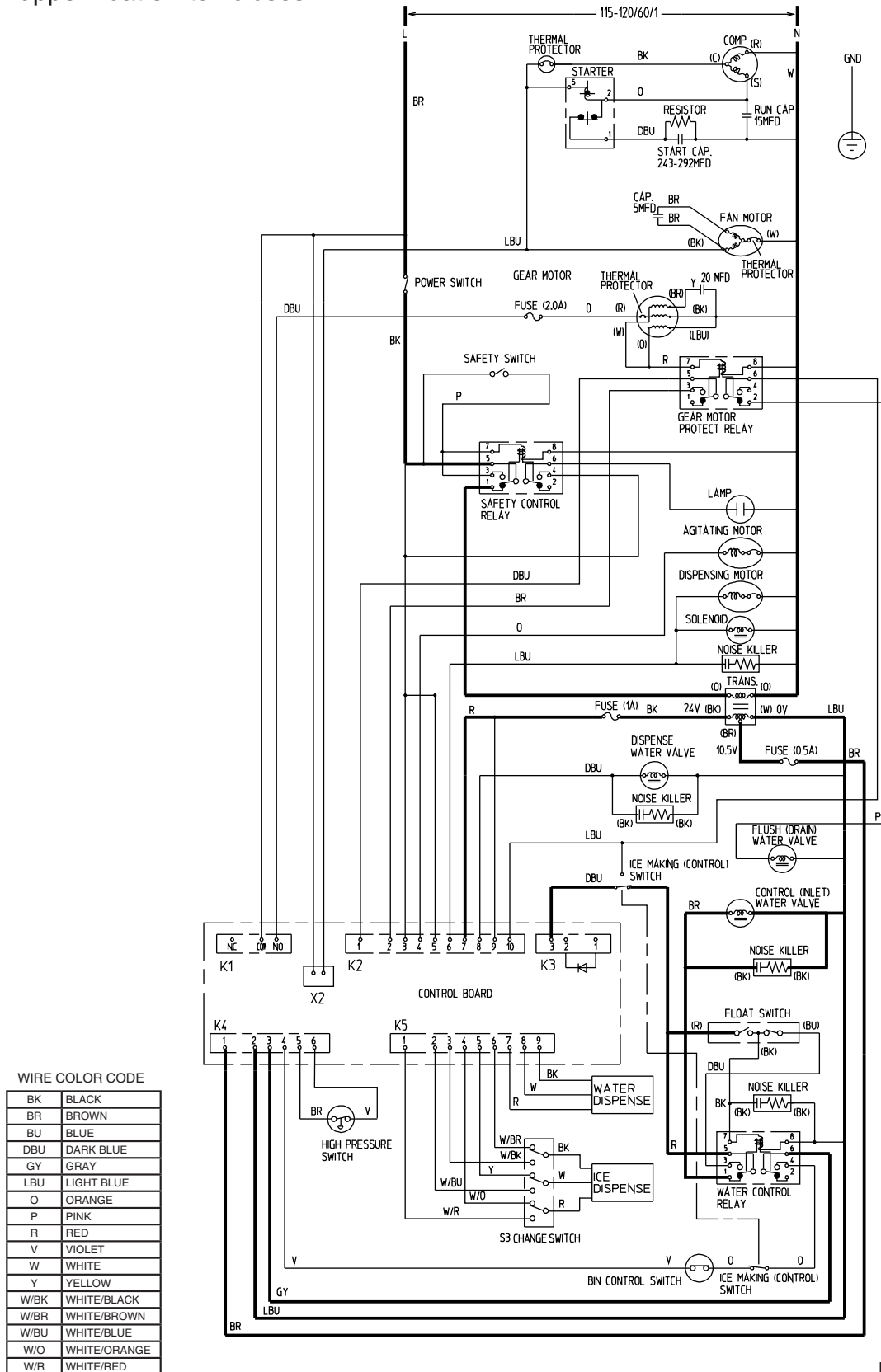
## 5. Shutdown

The bin control switch is activated and a 150 second shutdown sequence begins. After the bin control has been open for 90 seconds, the compressor and fan motor stop, the agitating motor operates for 0.6 seconds, and 60 seconds later the gear motor stops.



## 6. Low Water Safety

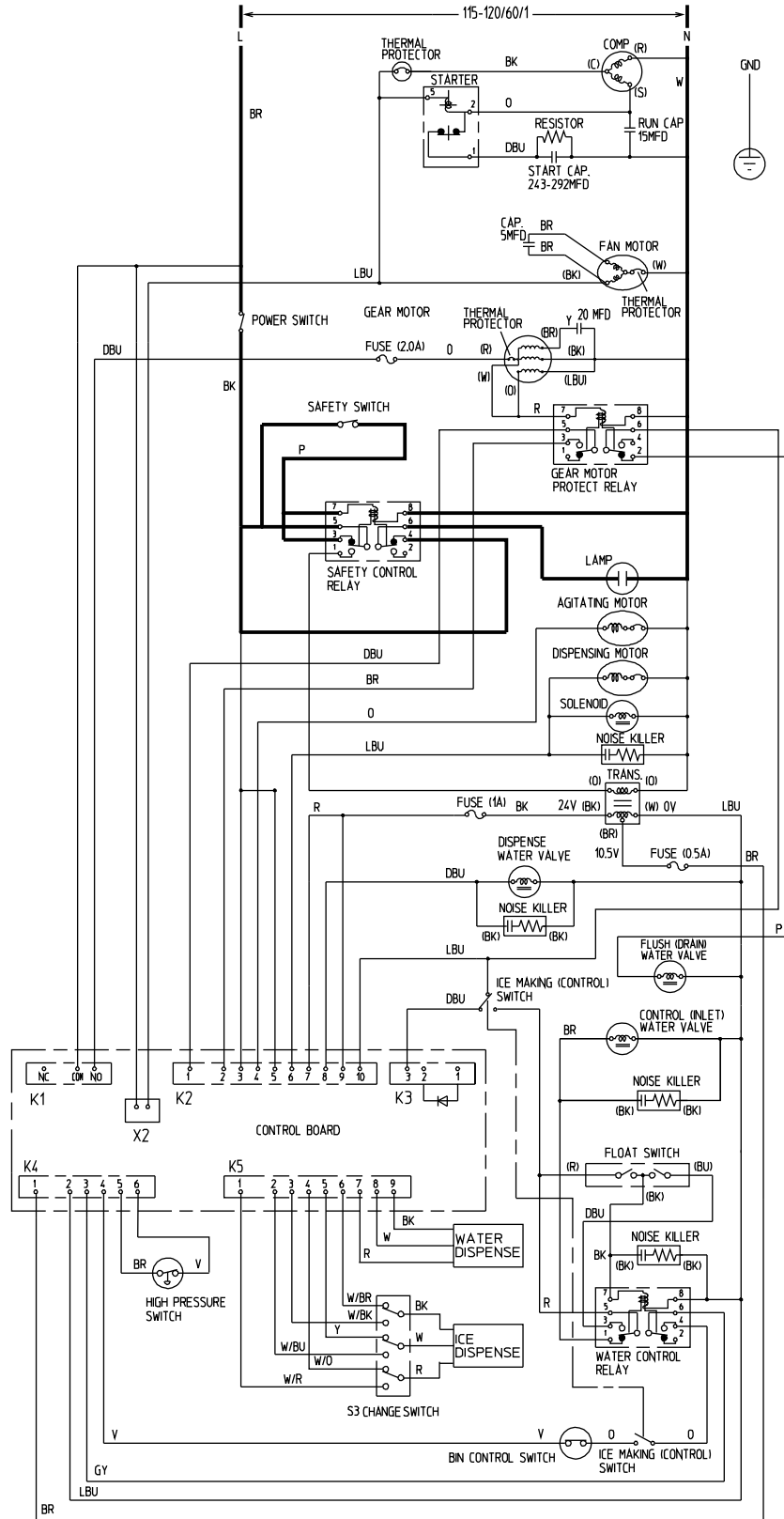
Upper float switch fails to close within 90 seconds after the lower float switch opens, the 150 second shutdown sequence begins. The inlet water valve remains open until the upper float switch closes.



DT-400BAH-OS

## 7. Safety Switch

When the safety switch is activated, the safety relay energizes, and the icemaker shuts down.

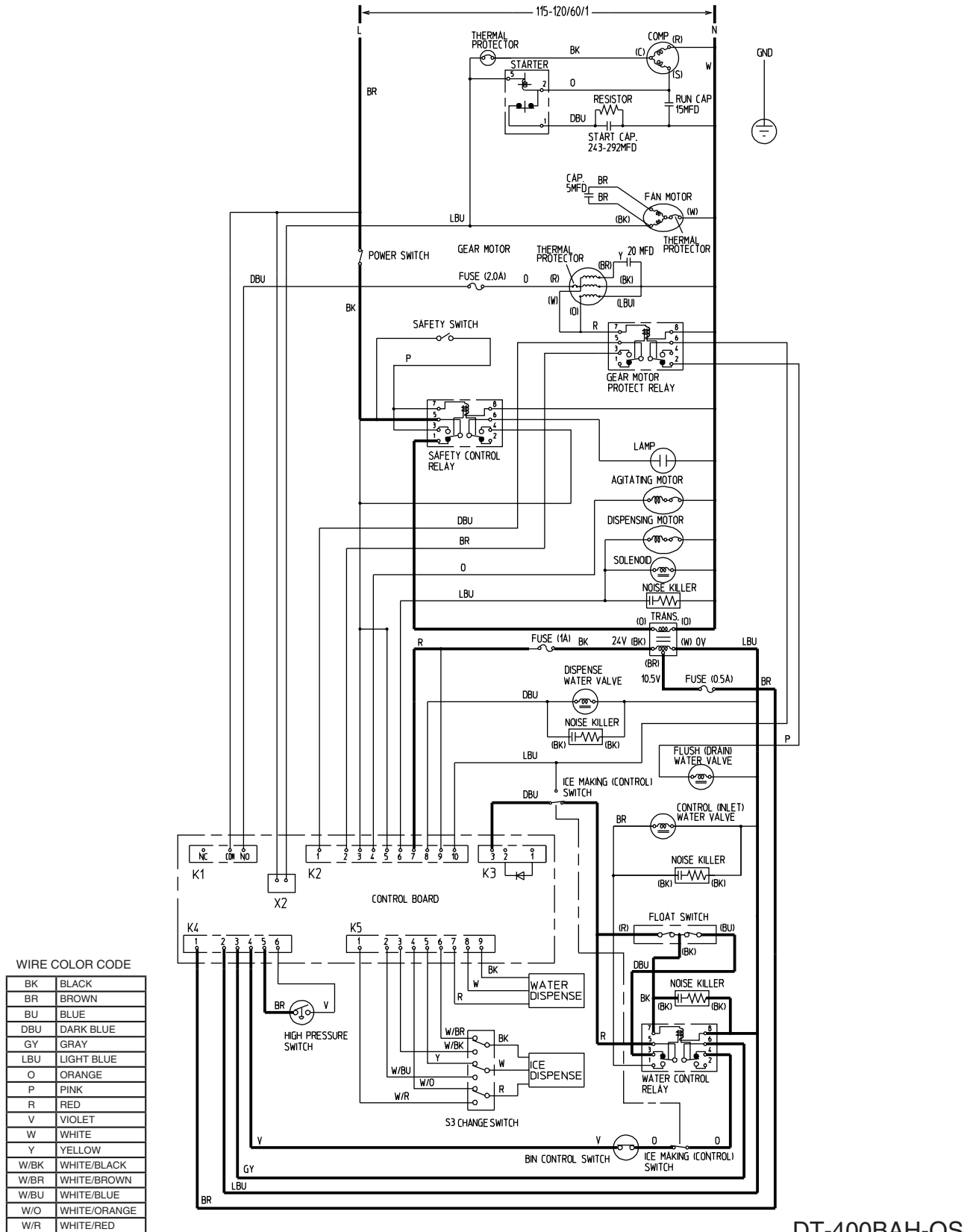


### WIRE COLOR CODE

BK	BLACK
BR	BROWN
BU	BLUE
DBU	DARK BLUE
GY	GRAY
LBU	LIGHT BLUE
O	ORANGE
P	PINK
R	RED
V	VIOLET
W	WHITE
Y	YELLOW
W/BK	WHITE/BLACK
W/BR	WHITE/BROWN
W/BU	WHITE/BLUE
W/O	WHITE/ORANGE
W/R	WHITE/RED

## 8. High Pressure Switch

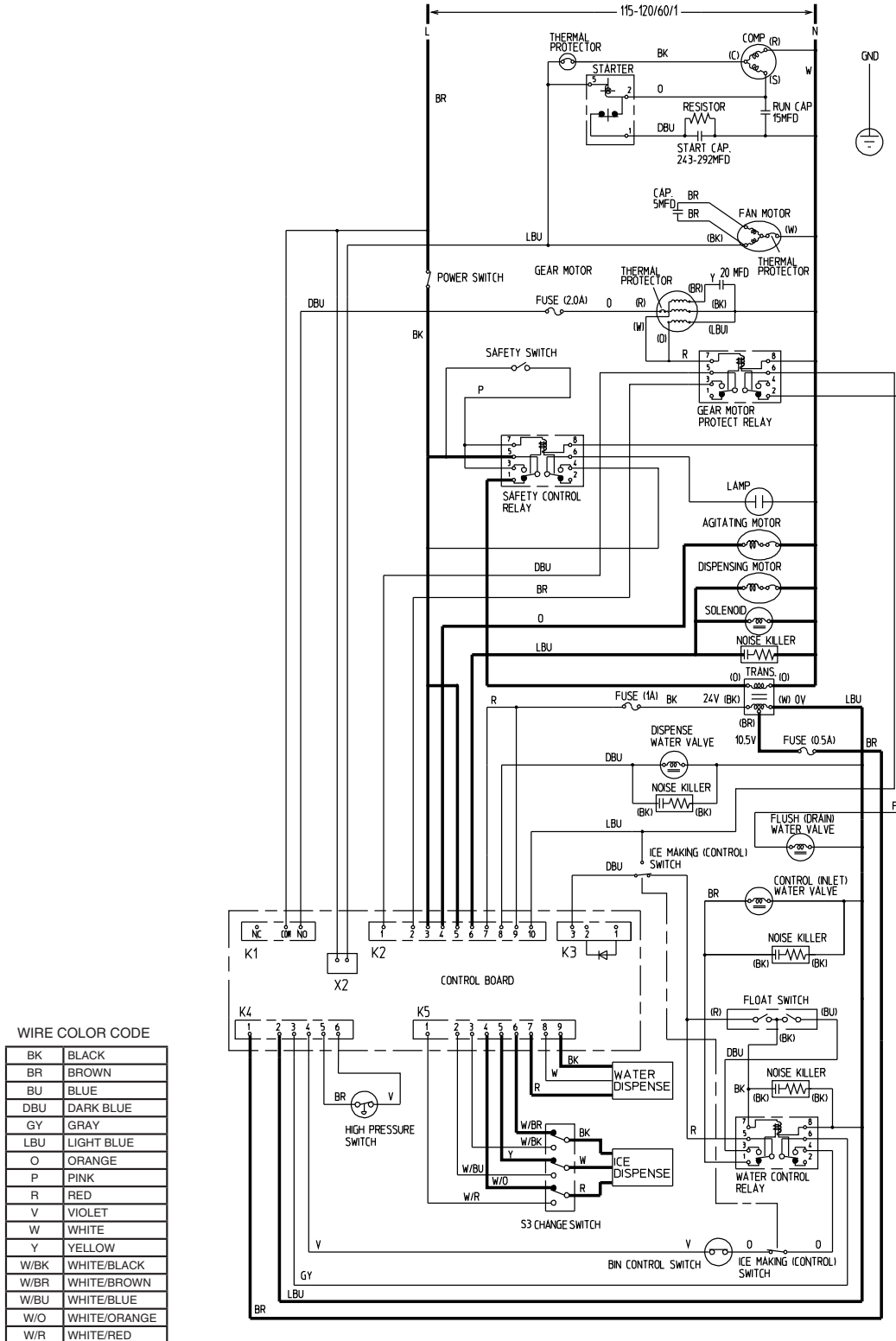
When the high pressure switch opens, the compressor stops immediately, 60 seconds later the gear motor stops. To restart, allow time for the high pressure switch to close, then move the power switch to the "OFF" position and then back to the "ON" position.



## D. Sequence of Electrical Circuit – Dispensing

### 1. Continuous Dispense

Agitating motor energizes for .6 seconds for every 12 seconds of accumulative dispense time. Maximum dispense time per dispense switch activation is 60 seconds. After 60 seconds, the dispense switch must be disengaged and engaged again.



DT-400BAH-OS

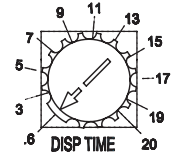
## 2. Portion Dispense

Agitating motor energizes for .6 seconds for every 12 seconds of accumulative dispense time. A variable resistor which controls the amount of ice dispensed is located on the control board. The figures on the label indicate dispensing time (sec.). See "II. D.3.a) Portion Control." When shipped, the portion control is set at the minimum dispensing time (0.6 sec.).

DT-400BAH-OS . . . . . Approximately 0.72 oz.

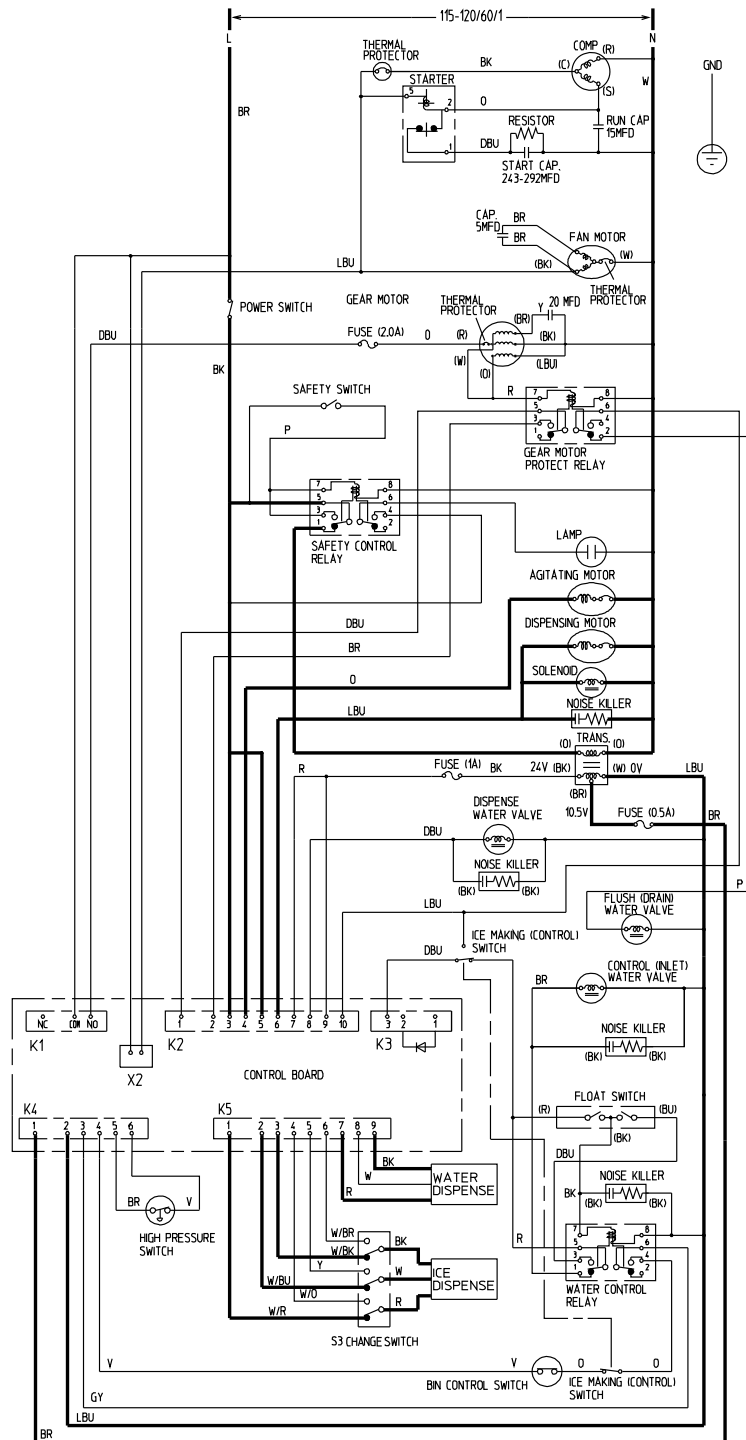
Amount of ice dispensed per second.

DT-400BAH-OS . . . . . Approximately 1.2 oz.



### WIRE COLOR CODE

BK	BLACK
BR	BROWN
BU	BLUE
DBU	DARK BLUE
GY	GRAY
LBU	LIGHT BLUE
O	ORANGE
P	PINK
R	RED
V	VIOLET
W	WHITE
Y	YELLOW
W/BK	WHITE/BLACK
W/BR	WHITE/BROWN
W/BU	WHITE/BLUE
W/O	WHITE/ORANGE
W/R	WHITE/RED



DT-400BAH-OS

## E. Performance Data

APPROXIMATE ICE PRODUCTION PER 24 HR.	Ambient Temp. (F)	Water Temp. (F)		
		50	70	90
lbs./day ( kg/day)	70	* 409 (186)	388 (176)	370 (168)
	80	354 (160)	338 (153)	322 (146)
	90	308 (140)	* 296 (134)	281 (127)
	100	268 (122)	256 (116)	* 242 (110)
APPROXIMATE ELECTRIC CONSUMPTION  watts	70	* 885 --	892 --	899 --
	80	906 --	914 --	921 --
	90	928 --	* 935 --	944 --
	100	952 --	961 --	* 969 --
APPROXIMATE WATER CONSUMPTION PER 24 HR. (TOTAL) gal. / day (l/day)	70	* 49 (186)	47 (176)	44 (168)
	80	42 (161)	41 (153)	39 (147)
	90	37 (140)	* 36 (135)	34 (128)
	100	32 (122)	31 (116)	* 29 (110)
EVAPORATOR OUTLET TEMP. °F (°C)	70	* 15 (-10)	16 (-9)	16 (-9)
	80	16 (-9)	16 (-9)	17 (-8)
	90	17 (-8)	* 17 (-8)	18 (-8)
	100	19 (-7)	19 (-7)	* 20 (-7)
HEAD PRESSURE  PSIG (kg/cm <sup>2</sup> G)	70	* 236 (16.6)	303 (21.3)	342 (24.0)
	80	236 (16.6)	303 (21.3)	342 (24.0)
	90	236 (16.6)	* 303 (21.3)	342 (24.0)
	100	236 (16.6)	303 (21.3)	* 342 (24.0)
SUCTION PRESSURE PSIG (kg/cm <sup>2</sup> G)	70	* 30 (2.1)	35 (2.5)	38 (2.7)
	80	30 (2.1)	35 (2.5)	38 (2.7)
	90	30 (2.1)	* 35 (2.5)	38 (2.7)
	100	30 (2.1)	35 (2.5)	* 38 (2.7)
TOTAL HEAT OF REJECTION		4923 BTU/h (AT 90°F / WT 70°F)		

Note:

1. The data without \*marks should be used for reference only.
2. We reserve the right to make changes in specifications and design without prior notice.

---

## IV. Service Diagnosis

### A. Diagnostic Procedure

This diagnostic procedure is a sequence check that allows you to diagnose the electrical system and components. Before proceeding, check for correct installation, adequate water supply (minimum of 10 PSIG, maximum of 113 PSIG) and proper voltage per unit nameplate. Always choose a white neutral wire to establish a good neutral connection when checking voltages. LEDs on the control board correspond to the components as they energize.

- 1) Move the control switch to the "OFF" position and unplug the icemaker from the electrical outlet. Remove the upper and lower front panels. Confirm the power switch is in the "ON" position.
- 2) Plug the icemaker back into the electrical outlet, then move the control switch to the "ICE" position. The "POWER" LED is on.
- 3) **Fill Cycle** – The inlet water valve energizes. The reservoir fills. The lower float switch closes. Nothing occurs at this time. The reservoir continues to fill until the upper float switch closes, energizing the water control relay, which closes the low water safety circuit and de-energizes the inlet water valve. **Diagnosis:** Check that the inlet water valve fills the reservoir. If not, check for water supply line shut-off valve closed, clogged water filters, clogged inlet water valve screen, power circuit to the inlet water valve (power switch, safety switch, safety relay contacts, transformer, fuses, high pressure switch, bin control, control switch, float switch, water control relay contacts), and the coil on the inlet water valve. Check that the inlet water valve shuts off when the upper float switch closes. If not, check the float switch, water control relay, and inlet water valve.
- 4) **Ice Purge Cycle** – "GM" LED is on (60 second short cycle protection). The 60 second timer starts, the gear motor protect relay and gear motor energize. **Diagnosis:** Check that the gear motor starts. If not, check that the water control relay is energized (inlet water valve should be closed). Check the low water safety circuit on the water control relay (terminals 4 and 6), check for 115/120V at the K1 connector "COM" terminal to neutral and "NO" terminal to neutral on the control board (see wiring diagram), check the gear motor fuse (overload protector), thermal protector, gear motor capacitor, and motor windings. If the gear motor starts, but the auger does not turn, check the gear motor coupling between the auger and the gear motor. If the compressor starts at the same time the gear motor starts, check the X2 compressor relay on the control board.
- 5) **Freeze Cycle** – "GM", "COMP" LED are on. The compressor and fan motor energize, the gear motor protect relay, gear motor, and water control relay remain energized. Ice production begins 4 to 6 minutes after the compressor and fan motor start depending on ambient and water temperature conditions. **Diagnosis:** Check that the compressor and fan motor are running. If not, check for voltage on and to the compressor (X2 relay on the control board). Check that the gear motor protect relay circuit terminals 3 and 5 are closed, check the compressor internal overload (thermal protector), the compressor capacitors, fan capacitor, and voltage to the fan motor.

6) **Refill /Low Water Safety** – As ice is produced, the water level in the reservoir drops. As the water level drops, the upper and lower float switches open. First, the upper float switch opens. Nothing occurs at this time. When the lower float switch opens, refill begins. The water control relay de-energizes, the 90 second low water safety timer begins, and the inlet water valve energizes. The compressor, fan motor, and gear motor continue to run. When the upper float switch closes, the water control relay energizes, the 90 second low water safety timer terminates, and the inlet water valve de-energizes.

If the upper float switch fails to close within 90 seconds after the inlet water valve energizes, a 150 second shutdown sequence begins. 90 seconds after the 90 second low water safety timer is complete, the compressor and fan motor de-energize, 60 seconds later the gear motor de-energizes. The inlet water valve continues until the upper float switch closes. **Diagnosis** – Check that the reservoir fills. If not, check the water supply line, clogged water filters, dirty or sticking float switches, inlet water valve screen, water control relay contacts, voltage to the inlet water valve, and inlet water valve solenoid or drain valve leaking.

7) **Drain Cycle** – "FLUSH" LED is on. 12 hour timer activates the flush cycle and a 150 second shutdown sequence begins. 90 seconds after the 12 hour timer activates, the compressor and fan motor de-energize, 60 seconds later the gear motor de-energizes. The drain valve then energizes and remains energized for 20 minutes. Once the 20 minute drain timer is complete, the 12 hour drain cycle timer resets and the fill cycle begins.

8) **Shutdown** – The bin fills and activates the bin control. A 150 second shutdown sequence begins. After the bin control has been open for 90 seconds, the compressor and fan motor stop, the agitating motor energizes for 0.6 seconds, and 60 seconds later the gear motor stops. **Diagnosis:** Check that the bin control paddle is activated and that the bin control switch opens. If the compressor and gear motor fail to stop, check the bin control (proximity) switch and control board relays.

## **B. Ice Production Check**

To check production, prepare a bucket or pan to catch the ice and a set of scales to weigh the ice. After the icemaker has operated for 10 to 20 minutes, catch the ice production for 10 minutes. Weigh the ice to establish the batch weight. Multiply the batch weight by 144 for the total production in 24 hours. When confirming production or diagnosing low production, see "III.E. Performance Data."

## C. Diagnostic Charts

### 1. No Ice Production

Problem	Possible Cause	Remedy	
[1] The icemaker will not start. (Fill Cycle)	a) Power Supply	1. Off, blown fuse, or tripped breaker.	1. Turn on, replace, or reset.
		2. Power cord unplugged.	2. Plug into receptacle.
		3. Loose connection.	3. Tighten.
		4. Bad contacts.	4. Check for continuity and replace.
		5. Not within specifications.	5. Refer to nameplate and correct.
	b) Water Supply	1. Water supply off or pressure too low.	1. Check and get recommended pressure.
	c) Power Switch (Control Box)	1. "OFF" position.	1. Move to "ON" position.
		2. Bad contacts.	2. Check for continuity and replace.
	d) Safety Switch and Relay	1. Bin control not activating and ice backed up.	1. Check bin control actuator and switch.
	e) Transformer	1. Coil winding open.	1. Replace.
	f) Fuses (2)	1. Blown.	1. Check for short circuit and replace.
	g) Control Switch	1. "OFF" or "DRAIN" position.	1. Move to "ICE" position.
		2. Bad contacts.	2. Check for continuity and replace.
	h) Water Control Relay	1. Bad contacts.	1. Check for continuity and replace.
		2. Coil winding open.	2. Replace.
	i) Inlet Water Valve	1. Mesh filter or orifice clogged.	1. Clean.
		2. Coil winding open.	2. Replace.
		3. Wiring to inlet water valve.	3. Check for loose or open connection. Repair or replace.
	j) Float Switch	1. Bad contacts.	1. Check for continuity and replace.
		2. Float does not move freely.	2. Clean or replace.
k) Bin Control	1. Open.	1. Bin full, check for continuity on proximity switch.	
	2. Actuator sticking.	2. Adjust or replace.	
	3. Proximity switch open.	3. Replace.	
l) High Pressure Switch	1. Bad contacts.	1. Check for continuity and replace.	
	2. Dirty air filter or condenser.	2. Clean.	

<b>Problem</b>	<b>Possible Cause</b>		<b>Remedy</b>
[1] The icemaker will not start. (Fill Cycle) (continued)	m) High Pressure Switch (continued)	3. Ambient or condenser water temperature too warm.	3. Reduce temperature.
		4. Refrigerant overcharged.	4. Recover, evacuate, and recharge.
		5. Fan not operating (except water-cooled model).	5. See "3.[2]a) Fan Motor."
		6. Refrigerant line or components restricted.	6. Remove the restriction or component and replace the drier.
		7. Condenser water pressure too low or off (water-cooled model only).	7. Check and get recommended pressure.
		8. Water regulating valve set too high (water-cooled model only).	8. Adjust it lower.
	n) Plug and Receptacle (Control Box)	1. Disconnected.	1. Connect.
		2. Loose terminal.	2. Repair terminal connection.
	o) Control Board	1. Defective.	1. See "II.D.4. Control Board Check Procedure."
[2] Fill cycle will not terminate.	a) Water Supply	1. Water supply off or pressure too low.	1. Check and get recommended pressure.
	b) Float Switch	1. Connector disconnected.	1. Reconnect.
		2. Float does not move freely.	2. Clean or replace.
		3. Defective switch.	3. Check and replace.
	c) Water Control Relay	1. Contacts sticking.	1. Replace.
		2. Coil winding open.	2. Replace.
	d) Drain Valve	1. Valve seat won't seal and water leaking.	1. Clean or replace.
e) Hoses	1. Disconnected or damaged.	1. Reconnect or replace.	
f) Control Board	1. Defective.	1. See "II.D.4. Control Board Check Procedure."	
[3] Ice purge cycle will not start.	a) Water Control Relay	1. Low water safety circuit open (bad contacts ).	1. Replace.
	b) Control Switch	1. Bad contacts.	1. Check for continuity and replace.
	c) Bin Control	1. Open.	1. Bin full, check for continuity on proximity switch.
	d) Control Board	1. Fails to operate gear motor relay.	1. See "II.D.4. Control Board Check Procedure."

<b>Problem</b>	<b>Possible Cause</b>		<b>Remedy</b>	
[3] Ice purge cycle will not start. (continued)	e) Gear Motor Fuse	1. Blown.	1. Check gear motor amperage, bearing wear (see "V.F.1. Upper Bearing Wear Check"), and supply voltage.	
	f) Gear Motor Thermal Protector	1. Open.	1. Check gear motor bearings, supply voltage.	
	g) Gear Motor	1. Open windings.	1. Replace.	
		2. Auger coupling broke.	2. Replace.	
	3. Locked bearings.	3. Replace.		
[4] Freeze cycle will not start (compressor).	a) Gear Motor Protect Relay	1. Open coil.	1. Replace.	
		2. Open contacts.	2. Replace.	
	b) Control Board	1. Defective.	1. See "II.D.4. Control Board Check Procedure."	
		c) Starter (Start Relay)	1. Bad contacts.	1. Check for continuity and replace.
			2. Coil winding open.	2. Replace.
		3. Loose connections.	3. Tighten.	
	d) Start Capacitor or Run Capacitor	1. Defective.	1. Replace.	
	e) Compressor	1. Power supply not within specifications.	1. Refer to nameplate and correct.	
		2. Wiring to compressor.	2. Check for loose or open connection, repair or replace.	
		3. Defective.	3. Replace.	
4. Compressor locked and internal motor protector tripped.		4. Replace.		
[5] All components run, but no ice is produced.	a) Refrigerant	1. Low charge.	1. See "V.B. Service for Refrigerant Lines."	
		2. Refrigerant line or component restricted.	2. Remove the restriction or component and replace the drier.	
		3. Air or moisture trapped.	3. Recover refrigerant, replace drier, evacuate, and recharge.	
	b) Expansion Valve	1. Bulb loose.	1. Secure bulb.	
		2. Operating erratically.	2. Check and replace.	
	c) Compressor	1. Defective.	1. Replace.	
	d) Evaporator	1. Defective.	1. Replace.	
	e) Water Supply Line (water-cooled model only)	1. Condenser water pressure too low or off and high pressure control opens and closes frequently.	1. Check and get recommended pressure.	
	f) Water Regulating Valve (water-cooled model only)	1. Water regulating valve set too high or clogged (water-cooled model only).	1. Clean, adjust, or replace.	

## 2. Low Ice Production

Problem	Possible Cause	Remedy	
[1] Low ice production.	a) Evaporator	1. Dirty or defective.	1. Clean or replace.
	b) Bin Control	1. Erratic, sticking, defective.	1. Clean or replace.
	c) Drain Valve	1. Leaking water.	1. Clean or replace.
	d) Expansion Valve	1. Bulb loose.	1. Secure bulb.
		2. Operating erratically.	2. Check and replace.
	e) Refrigerant Charge	1. Low charge.	1. See "V.B. Service for Refrigerant Lines."
		2. Overcharge.	2. See "V.B. Service for Refrigerant Lines."
	f) Refrigerant Line	1. Refrigerant line or component restricted.	1. Repair/replace the clogged line/component and replace the drier.
	g) High-Side Pressure Too High	1. Dirty air filter or condenser.	1. Clean.
		2. Ambient (or condenser) water temperature too warm.	2. Reduce temperature.
		3. Fan motor slow rpm.	3. See "3. [2] a) Fan Motor."
		4. Fan motor capacitor.	4. Check and replace.
		5. Condenser water pressure too low or off (water-cooled model only).	5. Check and get recommended pressure.
		6. Water regulating valve set too high or clogged (water-cooled model only).	6. Clean, adjust, or replace.
	h) Compressor	1. Inefficient compressor.	1. Replace
		2. Faulty thermal protector (overload).	2. Replace compressor.
		3. Faulty capacitor/ starter.	3. Replace.

## 3. Other

Problem	Possible Cause	Remedy	
[1] Icemaker will not stop when bin is filled with ice.	a) Bin Control	1. Actuator sticking.	1. Adjust or replace.
		2. Proximity switch closed.	2. Replace.
[2] Abnormal noise.	a) Fan Motor (except water-cooled model)	1. Bearing worn out.	1. Replace.
		2. Fan blade deformed.	2. Replace fan blade.
		3. Fan blade does not move freely.	3. Replace.
	b) Compressor	1. Bearings worn out, or cylinder valve broken.	1. Replace.
		2. Mounting pad out of position.	2. Reinstall.

<b>Problem</b>	<b>Possible Cause</b>		<b>Remedy</b>
[2] Abnormal noise. (continued)	c) Refrigerant Lines	1. Rub or touch other lines or surfaces.	1. Reposition.
	d) Auger	1. Bearings or auger worn out.	1. Replace bearings or auger. See "V.F. Removal and Replacement of Evaporator Assembly Components."
	e) Gear Motor	1. Bearing or gear worn out / damaged.	1. Replace.
	f) Evaporator	1. Scale on inside wall of evaporator freezing cylinder.	1. Use "SCALE AWAY" or "LIME-A-WAY" solution to clean periodically. See "VI. A. Cleaning and Sanitizing Instructions." If the water is found hard by testing, install a softener.
2. Evaporator defective.		2. Replace.	
[3] Overflow from reservoir (water does not stop).	a) Water Supply	1. Water pressure too high.	1. Install a pressure reducing valve.
	b) Inlet Water Valve	1. Diaphragm does not close.	1. Clean or replace.
	c) Float Switch	1. Bad contacts.	1. Check for continuity and replace.
	d) Water Control Relay	1. Bad contacts.	1. Replace
[4] Gear motor overload protector operates frequently or fuse blows frequently.	a) Power Supply	1. Not within specifications.	1. Refer to nameplate and correct.
	b) Evaporator Assembly	1. Bearings or auger worn out.	1. Replace bearings or auger. See "V.F.1. Upper Bearing Wear Check."
	c) Bin Control	1. Bad contacts.	1. Check for continuity and replace.
		2. Actuator does not move freely.	2. Clean actuator or replace bin control assembly.
	d) Safety Switch and Relay	1. Switch misaligned, contacts bad.	1. Check and correct or replace.
e) Control Board	1. Erratic operation of gear motor relay.	1. See "II.D.4. Control Board Check Procedure."	

#### 4. Dispensing

<b>Problem</b>	<b>Possible Cause</b>		<b>Remedy</b>
[1] No ice dispensed.	a) Power Supply	1. "OFF" position.	1. Move to "ON" position.
		2. Loose connection.	2. Tighten.
		3. Bad contacts.	3. Check for continuity and replace.
		4. Not within specifications.	4. Refer to nameplate and correct.

<b>Problem</b>	<b>Possible Cause</b>		<b>Remedy</b>
[1] No ice dispensed. (continued)	b) Ice Storage	1. No ice or little ice in storage bin.	1. Make ice.
		2. Ice bridge or ice block formed.	2. Melt ice, resupply with new ice.
		3. Agitating motor defective.	3. Check, replace.
	c) Ice Dispense Sensor	1. Opti Serve sensor defective.	1. See "5. Opti Serve (OS) Sensors."
	d) Shutter Assembly	1. Defective, broken part.	1. Check and replace.
		2. Open windings on solenoid.	2. Check continuity and replace.
	e) Dispense Gear Motor	1. Thermal protector is tripped.	1. Allow to cool.
		2. Gear motor winding open.	2. Replace.
		3. Bearing worn out.	3. Replace.
		4. Wiring to gear motor.	4. Check for loose connection or open circuit, and replace wiring as needed.
		5. Defective capacitor.	5. Replace.
	f) Auger Mechanism	1. Bad alignment of auger.	1. Realign.
	g) Control Board	1. Defective.	1. See "II.D.4. Control Board Check Procedure."
[2] Abnormal noise.	a) Gear Motor or Gear Head	1. Bearing worn out.	1. Replace.
	b) Auger Mechanism	1. Bad alignment of auger.	1. Realign.
		2. Foreign matter interrupting agitator.	2. Remove foreign matter.
	c) Dispense Water Solenoid	1. Vibration due to loosening screws.	1. Apply thread sealant to the parts and tighten.
[3] No water dispensed.	a) Power Supply	1. "OFF" position.	1. Move to "ON" position.
	b) Water Supply	1. Water supply off or pressure too low.	1. Check and get recommended pressure.
	c) Dispensing Water Valve	1. Coil winding open.	1. Replace.
		2. Wiring to dispensing water valve.	2. Check for loose or open connection. Repair or replace.
	d) Control Board	1. Defective.	1. See "II.D.4. Control Board Check Procedure."
	e) Water Dispense Sensor	1. Opti Serve sensor defective.	1. See "5. Opti Serve (OS) Sensors."

## 5. Opti Serve (OS) Sensors

Be sure to check all items in section "IV.C.4. Dipsensing" prior to using this chart. Use the following charts along with the wiring diagram to troubleshoot the OS sensors.

Problem	Possible Cause		Remedy
[1] No ice dispensed.	a) OS Sensor	1. Dirty sensor.	1. Clean, using Scale Away (6 fl. oz. (0.8 l) per 1 gal. (3.8 l) of water) or other non-abrasive cleaner.
		2. Defective.	2. See chart 5a and 5b below.
	b) Change Switch (Dispense Mode Switch)	1. Wrong setting.	1. Move to desired setting.
		2. Bad contacts.	2. Check for continuity and replace.
		3. Loose connection.	3. Tighten.
	c) Control Board	1. Loose connection.	1. Tighten.
2. Defective.		2. See "II.D.4. Control Board Check Procedure" and chart 5a and 5b below.	
[2] No water dispensed.	a) OS Sensor	1. Dirty sensor.	1. Clean.
		2. Defective.	2. See chart 5c below.
	b) Change Switch (Dispense Mode Switch)	1. Wrong setting.	1. Move to desired setting.
		2. Bad contacts.	2. Check for continuity and replace.
		3. Loose connection.	3. Tighten.
	c) Control Board	1. Loose connection.	1. Tighten.
2. Defective.		2. See "II.D.4. Control Board Check Procedure" and chart 5c below.	

### 5a. Ice Dispensing "Continuous" Mode

Component	Control Board	Sensor		Control Board /Other	Sensor	On	Off
Solenoid	K2 Pin 6 LBU	-	To	Neutral/GND	-	120VAC	0VAC
Sensor	K5 Pin 4 W/O	R	To	K5 Pin 5 Y	WH	5VDC	0VDC
				K5 Pin 6 W/BR	BK	5VDC	5VDC

### 5b. Ice Dispensing "Portion" Mode

Component	Control Board	Sensor		Control Board /Other	Sensor	On	Off
Solenoid	K2 Pin 6 LBU	-	To	Neutral/GND	-	120VAC	0VAC
Sensor	K5 Pin 1 W/R	R	To	K5 Pin 2 W/BU	WH	5VDC	0VDC
				K5 Pin 3 W/BK	BK	5VDC	5VDC

### 5c. Water Dispensing

Component	Control Board		Control Board /Other	On	Off
Solenoid	K2 Pin 8 DBU	To	K4 Pin 2 (LBU)	24VAC	0VAC
Sensor	K5 Pin 7 R	To	K5 Pin 8 WH	5VDC	0VDC
			K5 Pin 9 BK	5VDC	5VDC

## V. Removal and Replacement of Components

### IMPORTANT

1. Ensure all components, fasteners, and thumbscrews are securely in place after the equipment is serviced.
2. The Polyol Ester (POE) oils used in R-404A units can absorb moisture quickly. Therefore it is important to prevent moisture from entering the system when replacing or servicing parts.
3. Always install a new drier every time the sealed refrigeration system is opened. Do not replace the drier until after all other repair or replacement has been made.
4. Do not leave the system open for longer than 15 minutes when replacing or servicing parts.

### A. Safety Switch

### CAUTION

This icemaker incorporates a spout safety switch (microswitch). Make sure that the safety switch components and spout are properly installed and aligned after making repairs. See Fig. 1. Failure to install the safety switch components and spout correctly could result in serious damage to the icemaker.

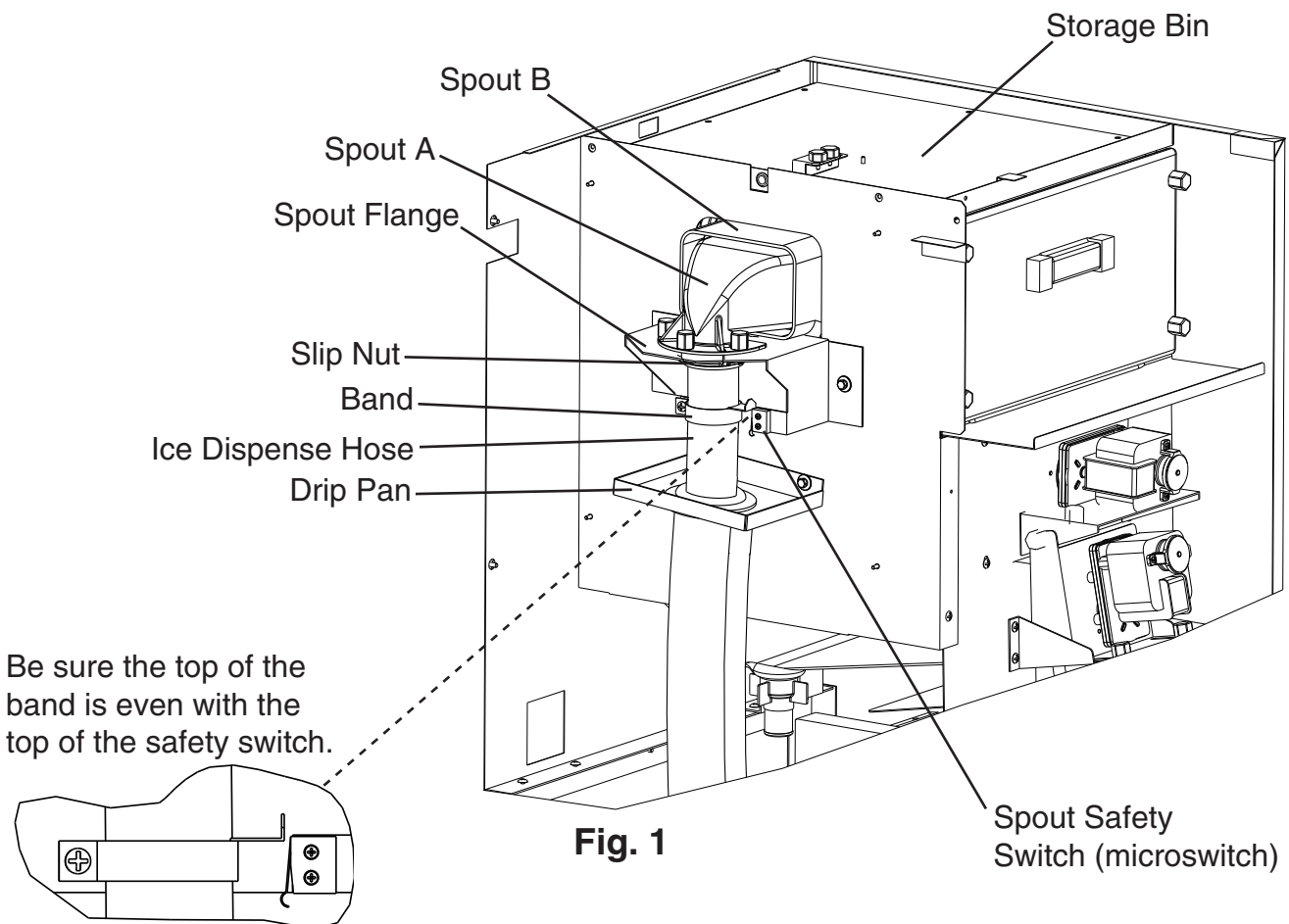


Fig. 1

## B. Service for Refrigerant Lines

### WARNING

Use an electronic leak detector or soap bubbles to check for leaks. Add a trace of refrigerant to the system (if using an electronic leak detector), and then raise the pressure using nitrogen gas (140 PSIG). DO NOT use R-404A as a mixture with pressurized air for leak testing.

### 1. Refrigerant Recovery

The icemaker is provided with refrigerant access valves. Using proper refrigerant practices, recover the refrigerant from the access valves and store it in an approved container. Do not discharge the refrigerant into the atmosphere.

### 2. Brazing

### WARNING

1. R-404A itself is not flammable at atmospheric pressure and temperatures up to 176°F (80°C).
2. R-404A itself is not explosive or poisonous. However, when exposed to high temperatures (open flames), R-404A can be decomposed to form hydrofluoric acid and carbonyl fluoride both of which are hazardous.
3. Always recover the refrigerant and store it in an approved container. Do not discharge the refrigerant into the atmosphere.
4. Do not use silver alloy or copper alloy containing arsenic.
5. Use an electronic leak detector or soap bubbles to check for leaks. Add a trace of refrigerant to the system (if using an electronic leak detector), and then raise the pressure using nitrogen gas (140 PSIG). DO NOT use R-404A as a mixture with pressurized air for leak testing.

- 1) Always install a new drier every time the sealed refrigeration system is opened. Do not replace the drier until after all other repair or replacement has been made. Install the new drier with the arrow on the drier in the direction of the refrigerant flow.
- 2) Braze all fittings while purging with nitrogen gas flowing at a pressure of 3 to 4 PSIG.
- 3) Use an electronic leak detector or soap bubbles to check for leaks. Add a trace of refrigerant to the system (if using an electronic leak detector), and then raise the pressure using nitrogen gas (140 PSIG). DO NOT use R-404A as a mixture with pressurized air for leak testing.

### 3. Evacuation and Recharge (R-404A)

- 1) Attach a vacuum pump to the system. Be sure to connect the charging hoses to both high and low-side access valves.

#### **IMPORTANT**

The vacuum level and vacuum pump may be the same as those for current refrigerants. However, the rubber hose and gauge manifold to be used for evacuation and refrigerant charge should be exclusively for POE oils.

- 2) Turn on the vacuum pump. Open the service manifold valves. Never allow the oil in the vacuum pump to flow backwards.
- 3) Allow the vacuum pump to pull down to a 29.9" Hg vacuum. Evacuating period depends on pump capacity.
- 4) Close the low-side valve and high-side valve on the service manifold.
- 5) Disconnect the vacuum pump and attach a refrigerant service cylinder to the high-side line. Remember to loosen the connection and purge the air from the hose. See the nameplate for the required refrigerant charge. Hoshizaki recommends only virgin refrigerant or reclaimed refrigerant which meets ARI Standard No. 700-88 be used.
- 6) A liquid charge is recommended for charging an R-404A system. Invert the service cylinder and place it on scales. Open the high-side valve on the service manifold.
- 7) Allow the system to charge with liquid until the proper charge weight is met.
- 8) If necessary, add any remaining charge to the system through the low-side. Use a throttling valve or liquid dispensing device to add the remaining liquid charge through the low-side access port with the unit running.
- 9) Close the service manifold valves and disconnect the service manifold hoses.
- 10) Cap the access valves to prevent a possible leak.

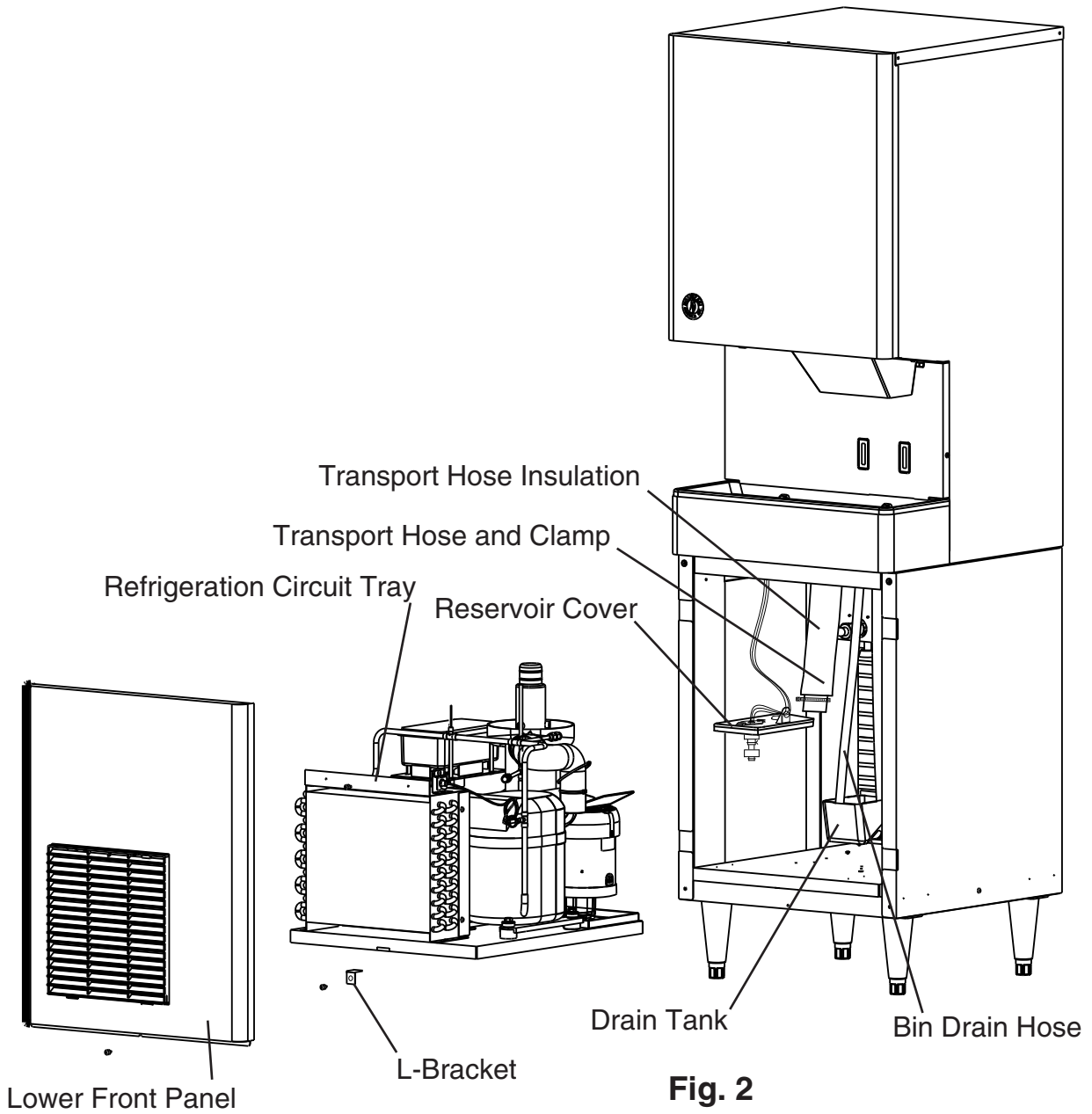
### C. Removal of Refrigeration Tray

#### **CAUTION**

When replacing certain components, the refrigeration tray must be removed. When reinstalling the refrigeration tray, make sure the drain hoses align properly over the drain tank in the rear of the machine. See Fig. 2.

- 1) Move the control switch to the "OFF" position, then unplug the unit from the electrical outlet.
- 2) Remove the lower front panel.
- 3) Remove the refrigeration circuit tray as described below. See Fig. 2.
  - a) Remove the screw and L-bracket at the base of the tray.
  - b) Move the water supply inlet reservoir hose coming into the top of the reservoir to the side and remove the reservoir cover.
  - c) Slide the refrigeration tray forward to the limit allowed by the transport hose sliding in the channel above. Support the front end of the refrigeration tray.

- d) Disconnect the 3 wiring connectors.
  - e) Disconnect the wires from the high pressure switch and the drain valve.
  - f) Remove the condensate hose from the hose bundle.
  - g) Raise the insulation on the transport hose. Loosen the clamp and disconnect the transport hose from the evaporator.
  - h) Remove the refrigeration circuit tray.
- 4) Proceed to the appropriate section below.



## D. Removal and Replacement of Compressor

### IMPORTANT

Always install a new drier every time the sealed refrigeration system is opened. Do not replace the drier until after all other repair or replacement has been made.

Note: When replacing a compressor with a defective winding, be sure to install the new start capacitor and start relay supplied with the replacement compressor. Due to the ability of the POE oil in the compressor to absorb moisture quickly, the compressor must not be opened more than 15 minutes for replacement or service. Do not mix lubricants of different compressors even if both are charged with R-404A, except when they use the same lubricant.

- 1) Remove the refrigeration tray as outlined in "V.C. Removal of Refrigeration Tray."
- 2) Recover the refrigerant and store it in an approved container.
- 3) Remove the terminal cover on the compressor and disconnect the compressor wiring.
- 4) Remove the drier, discharge, suction, and process pipes.
- 5) Remove the compressor hold-down bolts, washers, and rubber grommets.
- 6) Remove the compressor. Unpack the new compressor package.
- 7) Attach the rubber grommets of the prior compressor to the new compressor.
- 8) Place the compressor in position and secure it using the bolts and washers.
- 9) Place the new drier in position.
- 10) Remove plugs from the suction, discharge, and process pipes.
- 11) Braze all fittings while purging with nitrogen gas flowing at a pressure of 3 to 4 PSIG.
- 12) Use an electronic leak detector or soap bubbles to check for leaks. Add a trace of refrigerant to the system (if using an electronic leak detector), and then raise the pressure using nitrogen gas (140 PSIG). DO NOT use R-404A as a mixture with pressurized air for leak testing.
- 13) Evacuate the system, and charge it with refrigerant. See the nameplate for the required refrigerant charge.
- 14) Connect the terminals and replace the terminal cover in its correct position.
- 15) Replace the refrigeration tray in the reverse order of which it was removed.

### CAUTION

1. When reinstalling the refrigeration tray, make sure the drain hoses align properly over the drain tank in the rear of the machine. See Fig. 2.
2. Make sure wiring is properly secured by the wire saddle and clear of the fan blade.

- 16) Replace the lower cabinet stand panel in its correct position.
- 17) Plug the icemaker back in. Move the control switch to the "ICE" position to start the automatic icemaking process.

## E. Removal and Replacement of Expansion Valve

### IMPORTANT

Sometimes moisture in the refrigeration circuit exceeds the drier capacity and freezes up at the expansion valve. Always install a new drier every time the sealed refrigeration system is opened. Do not replace the drier until after all other repair or replacement has been made.

- 1) Remove the refrigeration tray as outlined in "V.C. Removal of Refrigeration Tray."
- 2) Recover the refrigerant and store it in an approved container.
- 3) Remove the insulation and the expansion valve bulb on the suction line.
- 4) Remove the expansion valve cover and disconnect the expansion valve.
- 5) Place the new expansion valve in position.
- 6) Remove the drier, then place the new drier in position.
- 7) Braze all fittings while purging with nitrogen gas flowing at a pressure of 3 to 4 PSIG.

### CAUTION

Always protect the valve body by using a damp cloth to prevent the valve from overheating. Do not braze with the valve body exceeding 250°F (121°C).

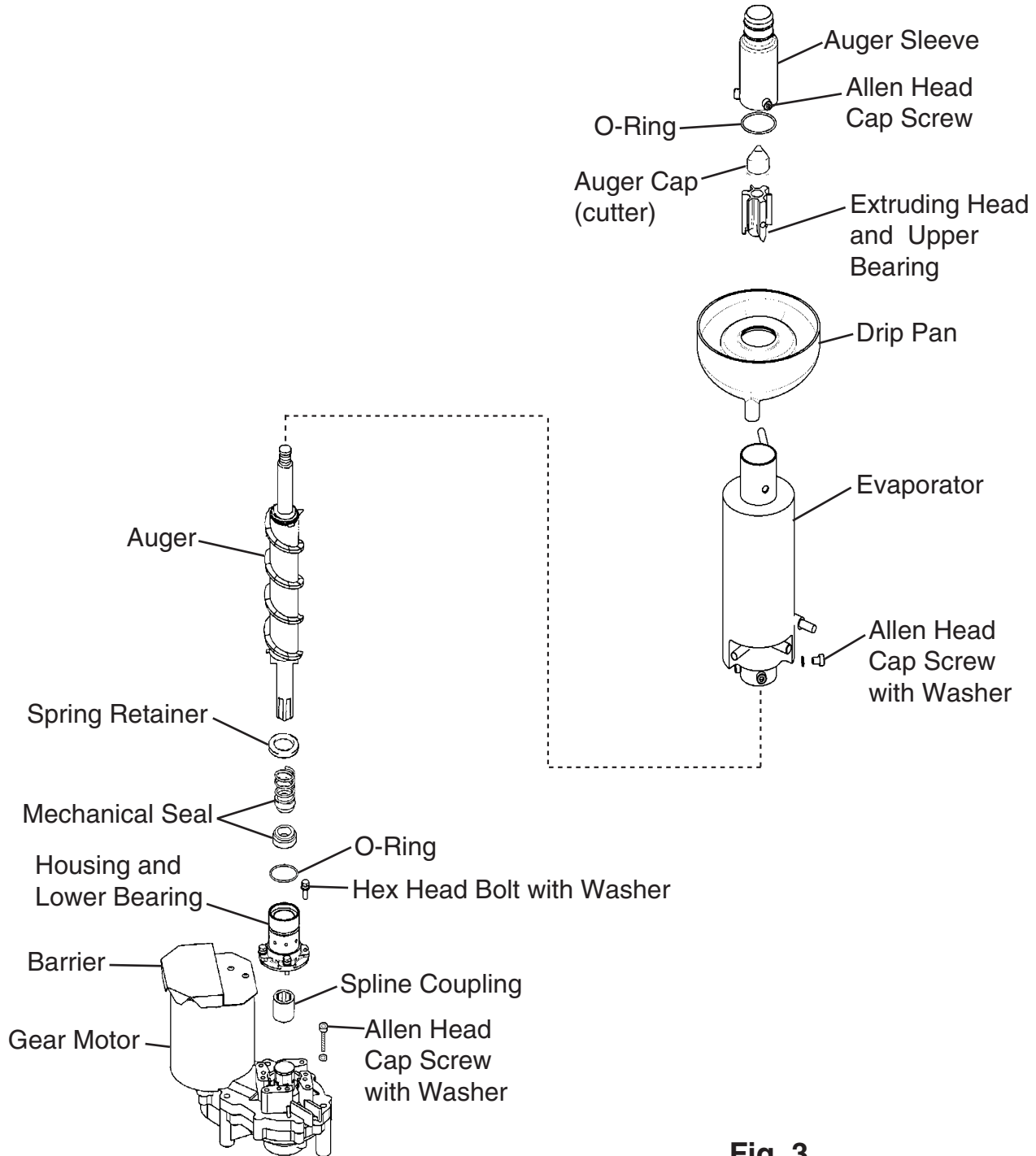
- 8) Use an electronic leak detector or soap bubbles to check for leaks. Add a trace of refrigerant to the system (if using an electronic leak detector), and then raise the pressure using nitrogen gas (140 PSIG). DO NOT use R-404A as a mixture with pressurized air for leak testing.
- 9) Evacuate the system, and charge it with refrigerant. See the nameplate for the required refrigerant charge.
- 10) Attach the expansion valve bulb to the suction line in the same location as the previous bulb. The bulb should be at the 12 o'clock position on the tube. Be sure to secure the bulb with the clamp and holder and to insulate it.
- 11) Place the expansion valve cover in position.
- 12) Replace the refrigeration tray in the reverse order of which it was removed.

### CAUTION

1. When reinstalling the refrigeration tray, make sure the drain hoses align properly over the drain tank in the rear of the machine. See Fig. 2.
2. Make sure wiring is properly secured by the wire saddle and clear of the fan blade.

- 13) Replace the lower cabinet stand panel in its correct position.
- 14) Plug the icemaker back in. Move the control switch to the "ICE" position to start the automatic icemaking process.

## F. Removal and Replacement of Evaporator Assembly Components

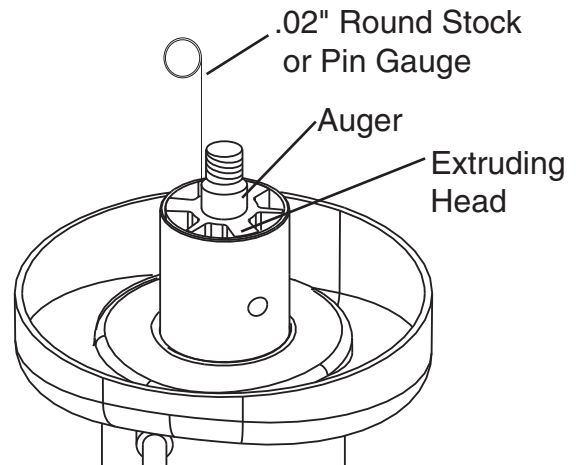


**Fig. 3**

## 1. Upper Bearing Wear Check

To ensure that the bearing inside the extruding head does not exceed the wear tolerance of .02", follow the instructions below. See Fig. 4.

- 1) Remove the refrigeration tray as outlined in "V.C. Removal of Refrigeration Tray."
- 2) Remove the allen head cap screws and lift off the auger sleeve and remove the auger cap. See Fig. 3.
- 3) Grasp the top of the auger and move the auger towards you and then try to insert a .02" round stock or pin gauge in between the back side of the auger shaft and the bearing surface. Check several locations around the auger shaft. If the gauge goes between the shaft and the bearing at any point or if the bearing is scratched or cracked, both the top bearing in the extruding head and the lower bearing in the housing should be replaced. Instructions for removing the extruding head and housing are located later in this procedure.



**Fig. 4**

Note: Replacing the bearing requires a bearing press adaptor. If one is not available, replace the whole extruding head and housing.

- 4) Replace the auger cap and auger sleeve in their correct positions.
- 5) Replace the refrigeration tray in the reverse order of which it was removed.

### **CAUTION**

1. When reinstalling the refrigeration tray, make sure the drain hoses align properly over the drain tank in the rear of the machine. See Fig. 2.
2. Make sure wiring is properly secured by the wire saddle and clear of the fan blade.

- 6) Replace the lower cabinet stand panel in its correct position.
- 7) Plug the icemaker back in. Move the control switch to the "ICE" position to start the automatic icemaking process.

## 2. Removal and Replacement of Extruding Head

- 1) Move the control switch to the "DRAIN" position and drain all of the water from the evaporator.
- 2) After the water has stopped draining, remove the refrigeration tray as outlined in "V.C. Removal of Refrigeration Tray."
- 3) Remove the allen head cap screws and lift off the auger sleeve. Remove the auger cap. See Fig. 3.
- 4) Remove the extruding head.

- 5) Place the new extruding head in place.
- 6) Replace the removed parts in the reverse order of which they were removed.
- 7) Replace the refrigeration tray in reverse order from which it was removed.

**CAUTION**

1. When reinstalling the refrigeration tray, make sure the drain hoses align properly over the drain tank in the rear of the machine. See Fig. 2.
2. Make sure wiring is properly secured by the wire saddle and clear of the fan blade.

- 8) Replace the lower cabinet stand panel in its correct position.
- 9) Plug the icemaker back in. Move the control switch to the "ICE" position to start the automatic icemaking process.

### **3. Removal and Replacement of Auger**

- 1) Move the control switch to the "DRAIN" position and drain all of the water from the evaporator.
- 2) After the water has stopped draining, remove the refrigeration tray as outlined in "V.C. Removal of Refrigeration Tray."
- 3) Remove the allen head cap screws and lift off the auger sleeve. Using the auger cap, lift out the auger assembly. See Fig. 3.
- 4) Remove the auger cap and extruding head from the auger and place them on the new auger.
- 5) Install the new auger.
- 6) Replace the removed parts in the reverse order of which they were removed.
- 7) Replace the refrigeration tray in the reverse order of which it was removed.

**CAUTION**

1. When reinstalling the refrigeration tray, make sure the drain hoses align properly over the drain tank in the rear of the machine. See Fig. 2.
2. Make sure wiring is properly secured by the wire saddle and clear of the fan blade.

- 8) Replace the lower front panel in its correct position.
- 9) Plug the icemaker back in. Move the control switch to the "ICE" position to start the automatic icemaking process.

#### 4. Removal and Replacement of Evaporator

##### **IMPORTANT**

Always install a new drier every time the sealed refrigeration system is opened. Do not replace the drier until after all other repair or replacement has been made.

- 1) Move the control switch to the "DRAIN" position and drain all of the water from the evaporator.
- 2) After the water has stopped draining, remove the refrigeration tray as outlined in "V.C. Removal of Refrigeration Tray."
- 3) Recover the refrigerant and store it in an approved container.
- 4) Remove the allen head cap screws and lift off the auger sleeve. Using the auger cap, lift out the auger assembly. See Fig. 3.
- 5) Disconnect the water hoses.
- 6) Disconnect the inlet and outlet tubing. Remove the drier, then place the new drier in position.
- 7) Remove the allen head cap screws securing the evaporator to the lower housing.
- 8) Lift off the evaporator.
- 9) Inspect the mechanical seal and O-ring prior to installing the new evaporator. The mechanical seal consists of two parts. One moves along with the auger, and the other is fixed on the lower housing. If the contact surfaces of these two parts are worn, cracked, or scratched, the mechanical seal may cause water leaks and should be replaced. Instructions for removing the mechanical seal and lower housing are located later in this procedure.
- 10) Make sure the lower mechanical seal is in place, then place the new evaporator in position. Secure the evaporator to the lower housing using the allen head cap screws.
- 11) Braze all fittings while purging with nitrogen gas flowing at a pressure of 3 to 4 PSIG.
- 12) Use an electronic leak detector or soap bubbles to check for leaks. Add a trace of refrigerant to the system (if using an electronic leak detector), and then raise the pressure using nitrogen gas (140 PSIG). DO NOT use R-404A as a mixture with pressurized air for leak testing.
- 13) Evacuate the system, and charge it with refrigerant. See the nameplate for the required refrigerant charge.
- 14) Replace the removed parts in the reverse order of which they were removed.
- 15) Replace the refrigeration tray in the reverse order of which it was removed.

##### **CAUTION**

1. When reinstalling the refrigeration tray, make sure the drain hoses align properly over the drain tank in the rear of the machine. See Fig. 2.
2. Make sure wiring is properly secured by the wire saddle and clear of the fan blade.

- 16) Replace the lower front panel in its correct position.
- 17) Plug the icemaker back in. Move the control switch to the "ICE" position to start the automatic icemaking process.

## **5. Removal and Replacement of Mechanical Seal and Lower Housing**

### **5a. Mechanical Seal**

- 1) Move the control switch to the "DRAIN" position and drain all of the water from the evaporator.
- 2) After the water has stopped draining, remove the refrigeration tray as outlined in "V.C. Removal of Refrigeration Tray."
- 3) Remove the allen head cap screws and lift off the auger sleeve. Using the auger cap, lift out the auger assembly. See Fig. 3.
- 4) The mechanical seal consists of two parts. One moves along with the auger, and the other is fixed on the lower housing. If the contact surfaces of these two parts are worn, cracked or scratched, the mechanical seal may cause water leaks and should be replaced.
- 5) Remove the allen head cap screws securing the evaporator to the lower housing.
- 6) Raise the evaporator up to access the lower housing.
- 7) Remove the mechanical seal from the housing. If only replacing the mechanical seal, proceed to step 9.

### **CAUTION**

To help prevent water leaks, be careful not to damage the surfaces of the O-ring or mechanical seal.

### **5b. Lower Housing**

- 8) Remove the O-ring and the bolts securing the housing to the gear motor and remove the housing from the gear motor. If inspection of the upper bearing inside the extruding head (see "V.F.1. Upper Bearing Wear Check") indicates that it is out of tolerance, replace both it and the bearing inside the lower housing.  
Note: Replacing the bearing requires a bearing press adaptor. If one is not available, replace the whole extruding head and housing.
- 9) Install the O-ring and mount the lower housing on the gear motor.
- 10) Install the lower part of the mechanical seal on the lower housing.
- 11) Lower the evaporator down and secure it to the lower housing.
- 12) Install the auger assembly with the upper part of the mechanical seal attached.
- 13) Replace the removed parts in the reverse order of which they were removed.

- 14) Replace the refrigeration tray in the reverse order of which it was removed.

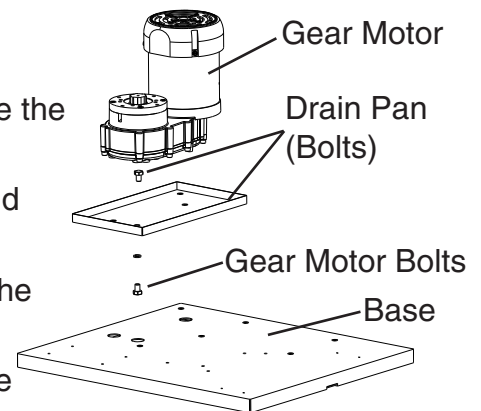
**CAUTION**

1. When reinstalling the refrigeration tray, make sure the drain hoses align properly over the drain tank in the rear of the machine. See Fig. 2.
2. Make sure wiring is properly secured by the wire saddle and clear of the fan blade.

- 15) Replace the lower front panel in its correct position.
- 16) Plug the icemaker back in. Move the control switch to the "ICE" position to start the automatic icemaking process.

### 6. Removal and Replacement of Gear Motor

- 1) Move the control switch to the "DRAIN" position and drain all of the water from the evaporator.
- 2) After the water has stopped draining, remove the refrigeration tray as outlined in "V.C. Removal of Refrigeration Tray."
- 3) Remove the bolts securing the lower housing to the gear motor. Lift the evaporator up slightly.
- 4) Remove the 2 bolts securing the gear motor drain pan.
- 5) Disconnect the wiring from the gear motor, then remove the gear motor and gear motor drain pan.
- 6) Remove the spline coupling from the old gear motor and attach to the new gear motor.
- 7) Remove the old gear motor from the drain pan, install the new gear motor to the drain pan.
- 8) Attach the gear motor drain pan (with gear motor) to the base.
- 9) Replace the removed parts in the reverse order of which they were removed.
- 10) Replace the refrigeration tray in reverse order from which it was removed.



**Fig. 5**

**CAUTION**

1. When reinstalling the refrigeration tray, make sure the drain hoses align properly over the drain tank in the rear of the machine. See Fig. 2.
2. Make sure wiring is properly secured by the wire saddle and clear of the fan blade.

- 11) Replace the lower front panel in its correct position.
- 12) Plug the icemaker back in. Move the control switch to the "ICE" position to start the automatic icemaking process.

## **G. Removal and Replacement of Fan Motor**

- 1) Move the control switch to the "OFF" position.
- 2) Unplug the icemaker from the electrical outlet.
- 3) Remove the lower cabinet stand panel.
- 4) Slide the refrigeration circuit tray forward as described below. See Fig. 3.
  - a) Remove the screw and L-bracket at the base of the tray.
  - b) Move the inlet reservoir hose coming into the top of the reservoir to the side.
  - c) Slide the refrigeration tray forward to the limit allowed by the transport hose sliding in the channel above. Support the front end of the refrigeration tray.
- 5) Disconnect the wire connectors from the fan motor leads.
- 6) Remove the fan motor bracket.
- 7) Remove the fan blade and install on the new fan motor.
- 8) Install the new fan motor on the fan motor bracket.
- 9) Replace the fan motor bracket in its correct position and reconnect the wire connectors.
- 10) Slide the refrigeration circuit tray back into position.
- 11) Realign the inlet reservoir hose.

### **CAUTION**

1. When reinstalling the refrigeration tray, make sure the drain hoses align properly over the drain tank in the rear of the machine. See Fig. 2.
2. Make sure wiring is properly secured by the wire saddle and clear of the fan blade.

- 12) Replace the lower cabinet stand panel in its correct position.
- 13) Plug the icemaker back in. Move the control switch to the "ICE" position to start the automatic icemaking process.

## **H. Removal and Replacement of Control or Dispensing Water Valve**

- 1) Close the water supply line shut-off valve.
- 2) Open the water supply line drain valve.
- 3) Move the control switch to the "OFF" position.
- 4) Unplug the icemaker from the electrical outlet.
- 5) For the control water valve, remove the lower front panel. For the dispensing water valve, remove the upper front panel.
- 6) Disconnect the wire terminals from the water valve.
- 7) Loosen the fitting nut on the water valve. Do not lose the washer inside the fitting nut.
- 8) Remove the water valve bracket.

- 9) Remove the old water valve and install the new water valve. Remove the supply hose from the old water valve and place on the new water valve.
- 10) Replace the water valve bracket in its correct position.
- 11) Reconnect the wire terminals.
- 12) Reconnect the fitting nut on the water valve. Make sure the washer is in place in the fitting nut.
- 13) Close the water supply line drain valve and open the water supply line shut-off valve.
- 14) Check for water leaks.
- 15) Replace the panel in its correct position.
- 16) Plug the icemaker back in. Move the control switch to the "ICE" position to start the automatic ice making process.

## **I. Removal and Replacement of Drain Valve**

- 1) Close the water supply line shut-off valve.
- 2) Move the control switch to the "OFF" position.
- 3) Unplug the icemaker from the electrical outlet.
- 4) Remove the lower front panel.
- 5) Slide the refrigeration circuit tray forward as described below. See Fig. 3.
  - a) Remove the screw and L-bracket at the base of the tray.
  - b) Move the water supply inlet reservoir hose coming into the top of the reservoir to the side.
  - c) Slide the refrigeration tray forward to the limit allowed by the transport hose sliding in the channel above. Support the front end of the refrigeration tray.
- 6) Prepare a container to catch water from the reservoir and evaporator, then disconnect the hose from the drain valve and allow all of the water from the reservoir and evaporator to drain into the container.
- 7) Disconnect the wire terminals from the drain valve.
- 8) Remove the drain valve bracket.
- 9) Remove the old drain valve and install the new drain water valve.
- 10) Replace the drain valve bracket in its correct position.
- 11) Reconnect the wires and hoses.
- 12) Slide the refrigeration circuit tray back into position. Realign the inlet reservoir hose.

### **CAUTION**

1. When reinstalling the refrigeration tray, make sure the drain hoses align properly over the drain tank in the rear of the machine. See Fig. 2.
2. Make sure wiring is properly secured by the wire saddle and clear of the fan blade.

- 13) Open the water supply line shut-off valve.
- 14) Plug the icemaker back in and move the control switch to the "ICE" position.
- 15) Allow the icemaker to fill for two minutes.
- 16) Move the control switch to the "OFF" position and unplug the icemaker from the electrical outlet.
- 17) Check for water leaks.
- 18) Plug the icemaker back in and move the control switch to the "DRAIN" position, and make sure water is draining into the drain pan, and that there are no water leaks around the hose connection. Confirm the drain hose is located in the drain pan.
- 19) Move the control switch to the "OFF" position.
- 20) Replace the cabinet stand panels in their correct positions.
- 21) Move the control switch to the "ICE" position to start the automatic ice making process.

## **J. Removal and Replacement of Dispensing System**

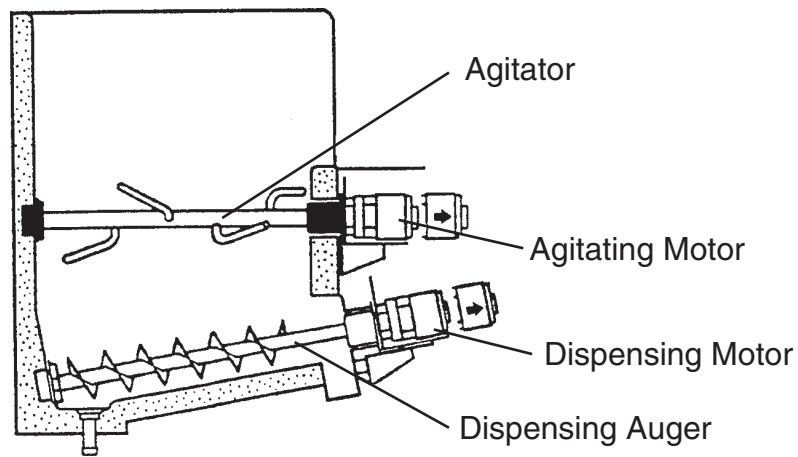
### **1. Dispensing Auger and Agitator**

- 1) Move the control switch to the "OFF" position.
- 2) Unplug the icemaker from the electrical outlet.
- 3) Remove the upper front panel.
- 4) Remove the front cover of the storage bin.
- 5) Remove the thumbscrews, first from the vertical plane and then from the horizontal plane of the motor brackets.  
Note: Hold the dispensing auger/agitator to prevent it from dropping when pulling off the gear motor bracket. See Fig. 6.
- 6) Replace the dispensing auger/agitator with the new one.
- 7) Assemble the removed parts in the reverse order of which they were removed.
- 8) Plug the icemaker back in. Move the control switch to the "ICE" position to start the automatic ice making process.

### **2. Dispensing or Agitating Motor**

- 1) Move the control switch to the "OFF" position.
- 2) Unplug the icemaker from the electrical outlet.
- 3) Remove the upper front panel.
- 4) Remove the storage bin front panel.
- 5) Remove the thumbscrews, first from the vertical plane and then from the horizontal plane of the motor brackets.  
Note: Hold the dispensing auger/agitator to prevent it from dropping when pulling off the gear motor bracket. See Fig. 6.
- 6) Remove the packing, three flat head screws, and plastic guide.

- 7) Remove the four flat head screws and the gear motor.
- 8) Install the new motor.
- 9) Assemble the removed parts in the reverse order of which they were removed.
- 10) Plug the icemaker back in. Move the control switch to the "ICE" position to start the automatic ice making process.



**Fig. 6**

---

## VI. Cleaning and Maintenance

### IMPORTANT

Ensure all components, fasteners, and thumbscrews are securely in place after any cleaning or maintenance is done to the equipment.

### WARNING

1. Hoshizaki recommends cleaning this icemaker at least twice a year. More frequent cleaning, however, may be required in some existing water conditions.
2. To prevent injury to individuals and damage to the icemaker, do not use ammonia type cleaners.
3. Carefully follow any instructions provided with the bottles of cleaning and sanitizing solution.
4. Always wear liquid-proof gloves to prevent the cleaning and sanitizing solutions from coming into contact with skin.
5. Never run the icemaker when the reservoir is empty.
6. After cleaning, do not use ice made from the cleaning and sanitizing solutions. Be careful not to leave any solution in the storage bin.

## A. Cleaning and Sanitizing Instructions - Water System

### 1. Cleaning Solution

Dilute approximately 9.6 fl. oz. (0.29 l) of recommended cleaner, Hoshizaki "Scale Away" or "LIME-A-WAY" (Economics Laboratory, Inc.), with 1.6 gallons (6.0 l) of warm water.

### 2. Cleaning Procedure

- 1) Close the water supply line shut-off valve.
- 2) Move the dispense mode switch to the "CONTINUOUS" position.
- 3) Activate the dispense sensor to remove the ice from the storage bin.
- 4) Move the control switch to the "DRAIN" position, and wait about 15 minutes for the water system to drain.
- 5) Move the control switch to the "OFF" position. Remove the upper front, top and left side panels.
- 6) Move the power switch to the "OFF" position. Unplug the icemaker from the electrical outlet.
- 7) Disconnect the ice transport hose from the spout, and pour the cleaning solution into the ice transport hose. Be careful not to overfill the reservoir. Reconnect the transport hose.

Note: If there is excess scale on the extruding head, fill the evaporator assembly and reservoir as described above, then use a clamp on the reservoir hose between the reservoir and evaporator assembly to block flow. Pour additional cleaning fluid into the transport hose until the evaporator assembly is completely full.

- 8) Allow the icemaker to sit for about 10 minutes before operation. If you placed a clamp on the reservoir hose in step 7, remove it before operation.
- 9) Plug the icemaker back in. Move the power switch to the "ON" position and replace the panels in their correct positions.
- 10) Move the control switch to the "ICE" position. Run the icemaker until it stops automatically.
- 11) Move the control switch to the "DRAIN" position, and wait about 15 minutes for the water system to drain.
- 12) After the water has drained, move the control switch to the "OFF" position. Remove the upper front, top and left side panels.
- 13) Move the power switch to the "OFF" position. Unplug the icemaker from the electrical outlet.
- 14) Disconnect the ice transport hose from the spout, and pour fresh water into the ice transport hose to rinse out the solution and fill the evaporator and reservoir. Be careful not to overfill the reservoir. Reconnect the transport hose.
- 15) Plug the icemaker back in. Move the power switch to the "ON" position and replace the panels in their correct positions.
- 16) Move the control switch to the "ICE" position. Run the icemaker until it stops automatically.
- 17) Move the control switch to the "DRAIN" position, and wait about 15 minutes for the water system to drain.  
Note: If you do not sanitize the icemaker, go to step 14 in "4. Sanitizing Procedure."

### **3. Sanitizing Solution**

Dilute approximately 0.82 fl. oz. (25 ml) of a 5.25% sodium hypochlorite solution (chlorine bleach) with 1.6 gallons (6.0 l) of warm water.

### **4. Sanitizing Procedure - Following Cleaning Procedure**

- 1) Move the control switch to the "OFF" position and remove the upper front, top and left side panels.
- 2) Move the power switch to the "OFF" position. Unplug the icemaker from the electrical outlet.
- 3) Disconnect the ice transport hose from the spout, and pour the sanitizing solution into the ice transport hose. Be careful not to overfill the reservoir. Reconnect the transport hose.
- 4) Plug the icemaker back in. Move the power switch to the "ON" position and replace the panels in their correct positions.
- 5) Allow the icemaker to sit for about 10 minutes before operation, then move the control switch to the "ICE" position. Run the icemaker until it stops automatically.
- 6) Move the control switch to the "DRAIN" position, and wait about 15 minutes for the water system to drain.
- 7) Repeat steps 1 through 6 one time.

- 8) Move the control switch to the "OFF" position. Remove the upper front, top and left side panels.
- 9) Move the power switch to the "OFF" position. Unplug the icemaker from the electrical outlet.
- 10) Disconnect the ice transport hose from the spout, and pour fresh water into the ice transport hose to rinse out the solution and fill the evaporator and reservoir. Be careful not to overfill the reservoir. Reconnect the transport hose.
- 11) Plug the icemaker back in. Move the power switch to the "ON" position and replace the panels in their correct positions.
- 12) Move the control switch to the "ICE" position. Run the icemaker until it stops automatically.
- 13) Move the control switch to the "DRAIN" position, and wait about 15 minutes for the water system to drain.
- 14) After the water has drained, move the control switch to the "OFF" position. Remove the upper front, top and left side panels.
- 15) Move the power switch to the "OFF" position. Unplug the icemaker from the electrical outlet.
- 16) Open the water supply line shut-off valve. Check for water leaks.
- 17) Plug the icemaker back in. Move the power switch to the "ON" position and replace the panels in their correct positions.
- 18) Move the control switch to the "ICE" position and run the icemaker about 30 minutes.
- 19) Move the control switch to the "OFF" position.
- 20) Activate the dispense sensor to remove the ice from the storage bin. Remove the upper front, top and left side panels.
- 21) Move the power switch to the "OFF" position. Unplug the icemaker from the electrical outlet.
- 22) Remove the front cover of the storage bin. Pour warm water into the storage bin to melt any remaining ice.
- 23) Clean the storage bin with water.

### **WARNING**

Do not use ice produced from the cleaning and sanitizing solution. Be sure no ice remains in the storage bin.

- 24) Replace the front cover of the storage bin, then plug the icemaker back in. Move the power switch to the "ON" position and replace the panels in their correct positions.
- 25) Move the control switch to the "DRAIN" position, and wait about 15 minutes for the water system to drain.  
Note: If cleaning the dispensing components, proceed to "B. Cleaning and Sanitizing Instructions - Dispensing Components."
- 26) After the water has drained, move the control switch to the "ICE" position to start the automatic icemaking process.

## B. Cleaning and Sanitizing Instructions - Dispensing Components

Perform following the cleaning and sanitizing procedures for the water system.

### 1. Cleaning Solution

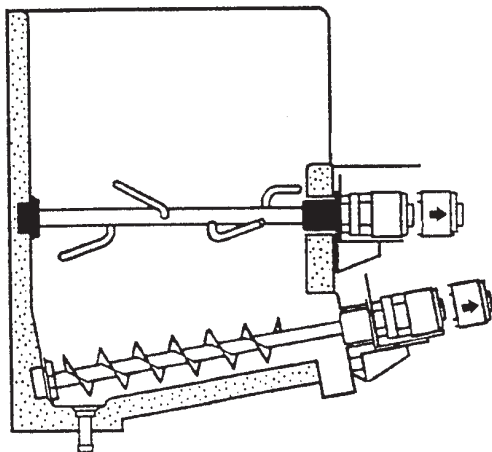
Dilute approximately 9.6 fl. oz. (0.29 l) of recommended cleaner, Hoshizaki "Scale Away" or "LIME-A-WAY" (Economics Laboratory, Inc.), with 1.6 gallons (6.0 l) of warm water.

### 2. Sanitizing Solution

Dilute approximately 0.82 fl. oz. (25 ml) of a 5.25% sodium hypochlorite solution (chlorine bleach) with 1.6 gallons (6.0 l) of warm water.

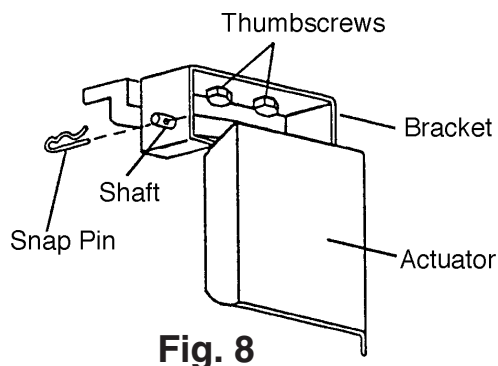
### 3. Dispensing Components Cleaning and Sanitizing Procedure

- 1) Move the control switch to the "OFF" position and remove the upper front and top panels.
- 2) Move the power switch to the "OFF" position. Unplug the icemaker from the electrical outlet.
- 3) Remove the front cover of the storage bin.
- 4) Remove the thumbscrews, first from the vertical plane and then from the horizontal plane of the motor brackets. Move the agitating motor and the dispensing motor towards you. Then remove the agitator and the auger (ice dispensing). See Fig. 7.

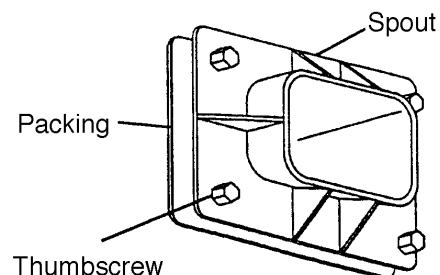


**Fig. 7**

- 5) Remove the bin control bracket assembly. See Fig. 8.
- 6) Remove the snap pin, shaft and actuator.
- 7) Remove the thumbscrews, spout and packing. See Fig 9.

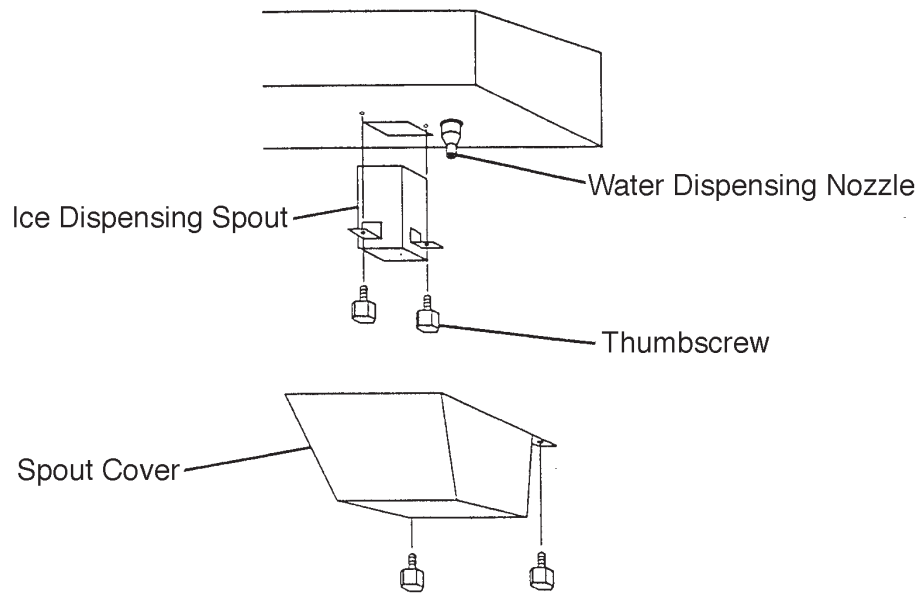


**Fig. 8**



**Fig. 9**

- 8) Remove the thumbscrews, spout cover, ice dispensing spout, and water dispensing nozzle. See Fig. 10.



**Fig. 10**

- 9) Immerse the parts removed in steps 4 through 8 in the cleaning and sanitizing solutions for about 15 minutes each.
- 10) Rinse these parts thoroughly with clean water.
- 11) Thoroughly wipe the shutter located above the ice dispensing spout.
- 12) Reassemble the bin control bracket assembly.
- 13) Place the auger (ice dispensing), agitator, bin control bracket assembly, spout, packing, ice dispensing spout, water dispensing nozzle and spout cover back in position.
- 14) Clean the storage bin liner, and rinse thoroughly.
- 15) Plug the icemaker back in. Move the power switch to the "ON" position and replace all parts and panels in their correct positions.
- 16) Move the control switch to the "ICE" position to start the automatic icemaking process.

## C. Maintenance

### IMPORTANT

1. This icemaker must be maintained individually, referring to the instruction manual and labels provided with the icemaker.

2. To achieve optimum icemaker performance, the following parts need periodic inspection and maintenance:

Extruding Head and Upper Bearing

Housing and Lower Bearing

Evaporator Cylinder

Auger

Gear Motor

Mechanical Seal

These parts should be inspected at least once a year or every 10,000 hours of operation. Their service life, however, depends on water quality and environment. More frequent inspection and maintenance are recommended in bad or severe water conditions.

Replacement of the following consumable parts is recommended if wear exceeds factory recommendations:

Upper Bearing

Lower Bearing

Mechanical Seal

Consult with your local distributor about inspection and maintenance service. To obtain the name and phone number of your local distributor, visit our website at [www.hoshizaki.com](http://www.hoshizaki.com) or call Hoshizaki Technical Support at 1-800-233-1940 in the USA.

### 1. Icemaker and Storage Bin

- Hoshizaki recommends cleaning this icemaker at least twice a year. More frequent cleaning, however, may be required in some existing water conditions.
- The storage bin is for ice use only. Do not store anything else in the bin.

### 2. Air Filter

A plastic mesh air filter removes dirt and dust from the air and keeps the condenser from getting clogged. As the filter gets clogged, the icemaker's performance will be reduced. Check the filter at least twice a month. When clogged, use warm water and a neutral cleaner to wash the filter.

### 3. Condenser

Check the condenser once a year, and clean if necessary by using a brush or vacuum cleaner. More frequent cleaning may be required depending on the location of the icemaker.

### 4. Stainless Steel Exterior

To prevent corrosion, wipe the exterior occasionally with a clean, soft cloth. Use a damp cloth containing a neutral cleaner to wipe off oil or dirt build up.

## D. Preparing the Icemaker for Long Storage

### WARNING

When the icemaker is not used for two or three days under normal conditions, it is sufficient to only move the control switch to the "OFF" position. When storing the icemaker for extended time or in sub-freezing temperatures, turn the water off and drain out all water from the water lines and remove the ice from the bin. The bin should be cleaned and dried. Drain the icemaker water hoses using air or carbon dioxide to prevent damage at sub-freezing temperatures.

- 1) Close the water supply line shut-off valve.
- 2) Move the control switch to the "OFF" position.
- 3) Move the dispense mode switch to the "CONTINUOUS" position.
- 4) Activate the dispense sensor to remove the ice from the storage bin.
- 5) Move the control switch to the "ICE" position.
- 6) Allow the icemaker to make ice until it stops automatically.
- 7) Move the control switch to the "OFF" position.
- 8) Remove the upper front, top and left side panels.
- 9) Move the power switch to the "OFF" position.
- 10) Unplug the icemaker from the electrical outlet.
- 11) Remove the front cover of the storage bin. Pour warm water into the storage bin, to melt any remaining ice. Dry out the storage bin.
- 12) Disconnect the transport hose. Remove any ice remaining in the hose.
- 13) Replace the storage bin cover and transport hose in their correct positions.
- 14) Plug the icemaker back in.
- 15) Move the power switch to the "ON" position. Replace the panels in their correct positions.
- 16) Move the control switch to the "DRAIN" position and wait for about 15 minutes for the water system to drain.
- 17) After the water has drained, move the control switch to the "ICE" position.
- 18) Open the potable water supply line drain valve and blow the line out using compressed air or carbon dioxide.
- 19) Close the potable water supply line drain valve.
- 20) Move the control switch to the "OFF" position. Remove the front panel.
- 21) Move the power switch to the "OFF" position.
- 22) Unplug the icemaker.
- 23) Replace the front panel in its correct position.

### IMPORTANT

Before operating the icemaker again, check that the water supply line drain valve is closed, and open the water supply line shut-off valve.