



HOSHIZAKI

Instruction Manual

Self-Contained Cuber

Models

IM-200BAK



hoshizakiamerica.com

Issued: 9-15-2025

⚠ WARNING

Only qualified service technicians should install and service the appliance. To obtain the name and phone number of your local Hoshizaki Certified Service Representative, visit www.hoshizakiamerica.com. No installation, operation, or maintenance should be undertaken until the technician has thoroughly read this Instruction Manual. No service should be undertaken until the technician has thoroughly read the service manual available at www.hoshizakiamerica.com. Likewise, the owner/manager should not proceed to operate the appliance until the installer has instructed them on its proper operation. Failure to install, operate, and maintain the appliance in accordance with this manual will adversely affect safety, performance, component life, and warranty coverage and may result in costly water damage. Proper installation is the responsibility of the installer. Product failure or property damage due to improper installation is not covered under warranty.

Hoshizaki provides this manual primarily to assist qualified service technicians in the installation, operation, maintenance, and service of the appliance.

Should the reader have any questions or concerns which have not been satisfactorily addressed, please call, send an e-mail message, or write to the Hoshizaki Technical Support Department for assistance.

Phone: 1-800-233-1940; (770) 487-2331

E-mail: tech-support@hoshizaki.com

HOSHIZAKI AMERICA, INC.

618 Highway 74 South

Peachtree City, GA 30269

Attn: Hoshizaki Technical Support Department

NOTE: To expedite assistance, all correspondence/communication **MUST** include the following information:

- Model Number _____
- Serial Number _____
- Complete and detailed explanation of the problem.

IMPORTANT

This manual should be read carefully before the appliance is installed and operated. Read the warnings and guidelines contained in this manual carefully as they provide essential information for the continued safe use and maintenance of the appliance. Retain this manual for any further reference that may be necessary.

CONTENTS

Important Safety Information	4
I. Specifications.....	9
A. Construction.....	9
B. Electrical and Refrigerant Data	10
C. Dimensions/Connections	11
II. Installation Instructions	12
A. Location	12
B. Checks Before Installation.....	14
C. How to Remove Panels	15
D. Setup.....	16
E. Electrical Connection	17
F. Water Supply and Drain Connections	18
G. Final Checklist	20
III. Operating Instructions.....	21
A. Important Notes About Usage.....	21
B. Startup and Bin Control Check.....	22
C. Control Board Display	23
IV. Maintenance	24
A. User Maintenance Schedule	24
B. Service Maintenance Schedule.....	25
C. Cleaning and Sanitizing Instructions.....	25
1. Cleaning Procedure.....	25
2. Sanitizing Procedure - Following Cleaning Procedure	27
3. Bin Control Cleaning.....	28
V. Preparing the Appliance for Periods of Non-Use	29
VI. Decommissioning and Disposal	31

Important Safety Information

Throughout this manual, notices appear to bring your attention to situations which could result in death, serious injury, damage to the appliance, or damage to property.

	R-290 Class A3 Flammable Refrigerant Used
⚠ DANGER	Indicates a hazardous situation that, if not avoided, will result in death or serious injury.
⚠ WARNING	Indicates a hazardous situation that, if not avoided, could result in death or serious injury.
NOTICE	Indicates a situation that, if not avoided, could result in damage to the appliance or property.
IMPORTANT	Indicates important information about the use and care of the appliance.

⚠ DANGER

<p><u>Risk of Fire or Explosion</u> <u>Flammable Refrigerant Used</u></p> <ul style="list-style-type: none"> • Only qualified service technicians should install and service the appliance. • No installation, operation, or maintenance should be undertaken until the technician has thoroughly read this Instruction Manual. All safety precautions must be followed. • No service should be undertaken until the technician has thoroughly read the Service Manual available at www.hoshizakiamerica.com. All safety precautions must be followed. • This appliance to be installed in accordance with the Safety Standard for Refrigeration Systems ANSI/ASHRAE 15. • Follow handling instructions carefully in compliance with national regulations. • Do not use mechanical devices or other means to accelerate the defrosting process or to clean, other than those recommended by the manufacturer. • Do not puncture refrigerant tubing. Risk of fire or explosion due to puncture of refrigerant tubing; follow handling instructions carefully. 	<ul style="list-style-type: none"> • Servicing shall be done by trained service personnel with certified competence in handling flammable refrigerants to minimize the risk of possible ignition due to incorrect parts or improper service. • Component parts shall be replaced with like components. So as to minimize the risk of possible ignition due to incorrect parts. • Dispose of properly in accordance with federal or local regulations. • Do not pierce or burn. • Be aware that refrigerants may not contain an odor. • Do not damage the refrigeration circuit. • See nameplate for R-290 refrigerant charge: <ul style="list-style-type: none"> • If greater than 114 g (4 oz.), do not install in public corridor or lobby. • If greater than 152 g (5.3 oz.), do not install within 6 m (20 ft) of open flame. • The appliance shall be stored in a room without continuously operating ignition sources (for example: open flames, an operating gas appliance, or an operating electric heater).
---	---

⚠ DANGER continued

- Do not place any potential ignition sources in or near the appliance.
- Keep clear of obstruction all ventilation openings in the appliance enclosure or in the structure for building-in.
- No potential sources of ignition are to be used in the searching for or detection of refrigerant leaks.
- Do not use electrical appliances inside the appliance unless they are of the type recommended by the manufacturer.
- Do not store explosive substances such as aerosol cans with a flammable propellant in this appliance.
- Check that cabling will not be subject to wear, corrosion, excessive pressure, vibration, sharp edges, or any other adverse environmental effects. The check shall also take into account the effects of aging or continual vibration from sources such as compressors or fans.
- Ensure that the area is in the open or that it is adequately ventilated before breaking into the system or conducting any hot work. A degree of ventilation shall continue during the period that the work is carried out. The ventilation should safely disperse any released refrigerant and preferably expel it externally into the atmosphere.

**Risque D'Incendie ou D'Explosion
Fluide Frigorigène Inflammable Utilisé**

- Seuls des techniciens de service qualifiés doivent installer et entretenir l'appareil.
- Aucune installation, opération ou maintenance ne doit être entreprise avant que le technicien n'ait lu attentivement ce manuel d'instructions. Toutes les précautions de sécurité doivent être suivies.
- Aucune opération d'entretien ne doit être entreprise avant que le technicien n'ait lu attentivement le manuel d'entretien disponible sur le site www.hoshizakiamerica.com. Toutes les précautions de sécurité doivent être suivies.
- Cet appareil doit être installé conformément à la norme de sécurité pour les systèmes de réfrigération ANSI/ASHRAE 15.
- Suivez attentivement les instructions de manutention conformément aux règlements nationaux.
- Ne pas utiliser de dispositifs mécaniques ou d'autres moyens pour accélérer le processus de dégivrage ou pour nettoyer, autres que ceux recommandés par le fabricant.
- Ne pas perforer la conduite de fluide frigorigène. Risque d'incendie ou d'explosion en cas de perforation d'une canalisation de fluide frigorigène; suivez attentivement les instructions de manutention.
- L'entretien doit être effectué par du personnel formé et certifié pour la manipulation de réfrigérants inflammables afin de réduire au minimum le risque d'inflammation dû à des pièces incorrectes ou à un entretien inadéquat.

⚠ DANGER continued

- Les pièces doivent être remplacées par des pièces similaires, de manière à réduire au minimum le risque d'inflammation dû à des pièces incorrectes.
 - Mettre au rebut conformément aux règlements fédéraux ou locaux.
 - Ne pas percer ou brûler.
 - Attention, les fluides frigorigènes peuvent ne pas dégager d'odeur.
 - Ne pas endommager les composants du circuit de réfrigération.
 - Voir plaque signalétique pour la charge de réfrigérant R-290:
 - Si elle est supérieure à 114 g (4 oz.), ne pas l'installer dans un couloir public ou un hall d'entrée.
 - Si elle est supérieure à 152 g (5.3 oz.), ne pas l'installer à moins de 6 m (20 pi) d'une flamme nue.
 - L'appareil doit être entreposé dans un local ne contenant pas de sources d'inflammation permanentes (flammes nues, appareil à gaz ou dispositif de chauffage électrique en fonctionnement, par exemple).
 - Ne placer aucune source d'inflammation potentielle à l'intérieur ou à proximité de l'appareil.
 - Ne pas obstruer les ouvertures de ventilation dans l'enceinte de l'appareil ou dans la structure d'encastrement.
 - Aucune source potentielle d'inflammation ne doit être utilisée pour rechercher ou détecter des fuites de réfrigérant.
 - Ne pas utiliser d'appareils électriques à l'intérieur de l'appareil, sauf s'ils sont du type recommandé par le fabricant.
 - Ne pas entreposer dans cet appareil des substances explosives telles que des bombes aérosols contenant un gaz propulseur inflammable.
- Vérifier que le câblage ne sera pas soumis à l'usure, à la corrosion, à une pression excessive, à des vibrations, à des arêtes vives ou à tout autre effet environnemental négatif. Le contrôle doit également prendre en compte les effets du vieillissement ou des vibrations continues provenant de sources telles que les compresseurs ou les ventilateurs.
 - S'assurer que la zone est à l'air libre ou qu'elle est correctement ventilée avant de pénétrer dans le système ou d'effectuer un travail à chaud. Une certaine ventilation doit être maintenue pendant la durée des travaux. La ventilation doit permettre de disperser en toute sécurité tout réfrigérant libéré et, de préférence, de l'expulser dans l'atmosphère.

WARNING

The appliance should be destined only to the use for which it has been expressly conceived. Any other use should be considered improper and therefore dangerous. The manufacturer cannot be held responsible for injury or damage resulting from improper, incorrect, and unreasonable use. Failure to install, operate, and maintain the appliance in accordance with this manual will adversely affect safety, performance, component life, and warranty coverage and may result in costly water damage.

To reduce the risk of death, electric shock, serious injury, or fire, follow basic precautions including the following:

- This appliance is not intended for use above 2,000 m (6,561 ft). Installation above 2,000 m (6,561 ft) may adversely affect safety, performance, and component life.
- Wear appropriate personal protective equipment (PPE) when servicing the appliance.
- The appliance must be installed in accordance with applicable national, state, and local codes and regulations.
- The appliance requires an independent power supply of proper capacity. See the nameplate for electrical specifications. Failure to use an independent power supply of proper capacity can result in a tripped breaker, blown fuse, damage to existing wiring, or component failure. This could lead to heat generation or fire.

• **THE APPLIANCE MUST BE**

GROUNDING. The appliance is equipped with a NEMA 5-15 three-prong grounding plug  to reduce the risk of potential shock hazards. It must be plugged into a properly grounded, independent 3-prong wall outlet. If the outlet is a 2-prong outlet, it is your personal responsibility to have a qualified electrician replace it with a properly grounded, independent 3-prong wall outlet. Do not remove the ground prong from the power cord and do not use an adapter plug. Failure to follow these instructions may result in death, electric shock, or fire.

- To reduce the risk of electric shock, do not touch the control switch or plug with damp hands.
- To reduce the risk of electric shock, make sure the control switch is in the "OFF" position before plugging in or unplugging the appliance.
- Unplug the appliance before servicing.
- Do not use an appliance with a damaged power cord. The power cord should not be altered, jerked, bundled, weighed down, pinched, or tangled. Such actions could result in electric shock or fire. To unplug the appliance, be sure to pull the plug, not the cord, and do not jerk the cord.
- Do not use an extension cord.
- If the supply cord is damaged, it must be replaced by the manufacturer, its service agent, or similarly qualified persons in order to avoid a hazard. Upon replacement, the GREEN ground wire in the power cord must be connected to the designated grounding screw.
- Do not make any alterations to the appliance. Alterations could result in electric shock, injury, fire, or damage to the appliance.
- Appliance is heavy. Use care when lifting or positioning. Work in pairs when needed to prevent injury or damage.

⚠ WARNING continued

- The appliance is not intended for use by persons (including children) with reduced physical, sensory, or mental capabilities, or lack of experience and knowledge, unless they have been given supervision or instruction concerning use of the appliance by a person responsible for their safety.
- Do not splash, pour, or spray water directly onto or into the appliance. This might cause short circuit, electric shock, corrosion, or failure.
- Children should be properly supervised around the appliance.
- Do not climb, stand, or hang on the appliance or allow children or animals to do so. Serious injury could occur or the appliance could be damaged.
- Be careful not to pinch fingers when opening and closing the door. Be careful when opening and closing the door when children are in the area.
- Do not use combustible spray or place volatile or flammable substances in or near the appliance. They might catch fire.
- Keep the area around the appliance clean. Dirt, dust, or insects in the appliance could cause harm to individuals or damage to the appliance.

NOTICE

- Follow the water supply, drain connection, and maintenance instructions carefully to reduce the risk of costly water damage.
- In areas where water damage is a concern, install in a contained area with a floor drain.
- Install the icemaker in a location that stays above freezing. Normal operating ambient temperature must be within 45°F to 100°F (7°C to 38°C).

NOTICE

- To help ensure that the ice storage bin drain remains clear, follow the instructions in "IV.B. Cleaning and Sanitizing Instructions" as often as necessary for conditions. If the ice storage bin drain becomes clogged, water could build up in the bin and overflow, leading to costly water damage.
- Do not leave the appliance on during extended periods of non-use, extended absences, or in sub-freezing temperatures. To properly prepare the appliance for these occasions, follow the instructions in "V. Preparing the Appliance for Periods of Non-Use."
- If water collects in the bin and will not drain, turn off the icemaker and close the water supply line shut-off valve. Call for service.
- If water seeps from the base of the appliance, turn off the appliance and close the water supply line shut-off valve. Call for service. Failure to do so could lead to costly water damage.
- Do not place objects on top of the appliance.
- The ice storage bin is for ice use only. Do not store anything else in the ice storage bin.
- Protect the floor when moving the appliance to prevent damage to the floor.
- Do not allow the appliance to bear any outside weight.

I. Specifications

A. Construction

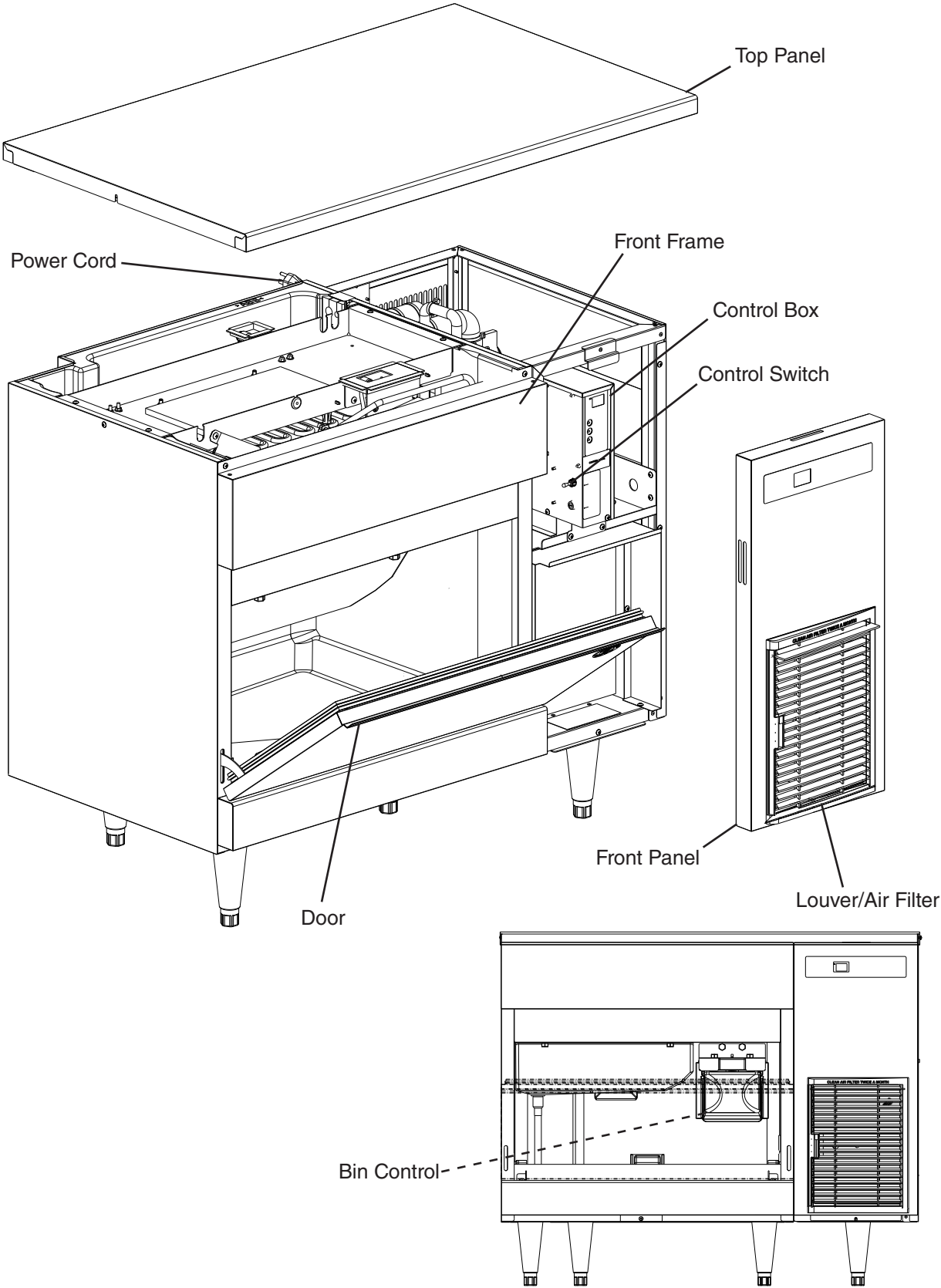

B. Electrical and Refrigerant Data

The rating label and nameplate provide electrical and refrigerant data. The rating label can be seen by removing the front panel. The nameplate is located on the rear panel. For certification marks, see the nameplate.

We reserve the right to make changes in specifications and design without prior notice.

1. IM-200BAK

Model Number	IM-200BAK
AC SUPPLY VOLTAGE	~115/60/1
AMPERES	5.0
DESIGN PRESSURE kPa (PSI)	HI-2069 (300) LO-896 (130)
REFRIGERANT g (oz.)	R-290 125 (4.4)
CLIMATIC CLASS	5
INSULATION BLOWING GAS	HFO 1233zd(E)
MINIMUM ROOM FLOOR AREA m ² (ft ²)	6.0 (64.4)
HARVEST RATE	≤1,000 LB/DAY (BATCH)

Note: Climatic Class 5: This appliance electrical safety tested for operation in maximum ambient temperature of 104°F (40°C) with 40% relative humidity. However, normal operating ambient temperature must be within 45°F to 100°F (7°C to 38°C); Normal operating water temperature must be within 45°F to 90°F (7°C to 32°C). Operation of the appliance, for extended periods, outside of these normal temperature ranges may affect appliance performance.

C. Dimensions/Connections

Unit: mm [inches]

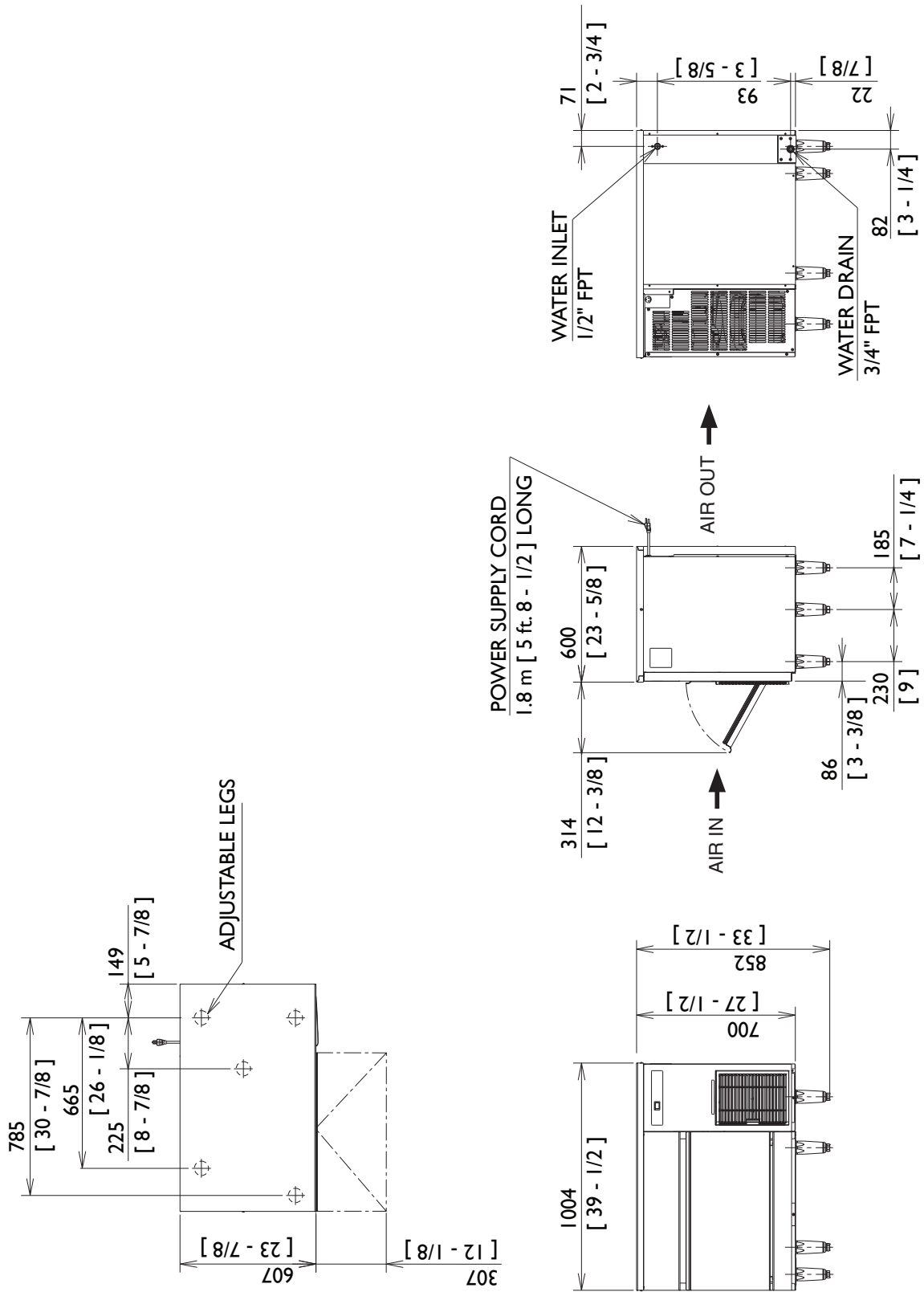

II. Installation Instructions

WARNING

- This appliance must be installed in accordance with applicable national, state, and local codes and regulations.
- This appliance to be installed in accordance with the Safety Standard for Refrigeration Systems ANSI/ASHRAE 15.
- Failure to install, operate, and maintain the appliance in accordance with this manual will adversely affect safety, performance, component life, and warranty coverage and may result in costly water damage.
- **CHOKING HAZARD:** Ensure all components, fasteners, and thumbscrews are securely in place after installation. Make sure that none have fallen into the ice storage bin.

A. Location

1. General

This appliance is approved for indoor use.

This appliance uses an A3 flammable refrigerant. For refrigerant charge and room floor area requirement, see the table below.

DANGER



R-290 Class A3 Flammable Refrigerant Used

Model	R-290 Refrigerant Charge g (oz.)	Minimum Room Floor Area (operating or storage) Superficie Minimale du Local (service ou stockage) m ² (ft ²); m ² (pi ²)
IM-200BAK	125 (4.4)	6.0 (64.4)



≥ Area m² (ft²) (see "Minimum Room Floor Area" above)
 ≥ Superficie m² (pi²) (voir « Superficie Minimale du Local » ci-dessus)

⚠ DANGER continued

R-290 Refrigerant Charge:

- If greater than 114 g (4 oz.), do not install in public corridor or lobby.
- If greater than 152 g (5.3 oz.), do not install within 6 m (20 ft) of open flame.

R-290 De réfrigérant:

- Si elle est supérieure à 114 g (4 oz.), ne pas l'installer dans un couloir public ou un hall d'entrée.
- Si elle est supérieure à 152 g (5.3 oz.), ne pas l'installer à moins de 6 m (20 pi) d'une flamme nue.

This appliance is not intended for use above 2,000 m (6,561 ft). Installation above 2,000 m (6,561 ft) may adversely affect safety, performance, and component life.

NOTICE

- Normal operating ambient temperature must be within 45°F to 100°F (7°C to 38°C); Normal operating water temperature must be within 45°F to 90°F (7°C to 32°C). Operation of the appliance, for extended periods, outside of these normal temperature ranges may affect appliance performance.
- This appliance will not work at sub-freezing temperatures. To prevent damage to the water supply line, drain the appliance if the air temperature is going to go below 32°F (0°C). See "V. Preparing the Appliance for Periods of Non-Use."

- The appliance should not be located next to ovens, grills, or other high heat producing equipment.
- In areas where water damage is a concern, install in a contained area with a floor drain.
- The location must provide a firm and level foundation for the appliance.
- Minimum Clearance:

Left Side and Top	Right Side	Rear
2" (5-cm) on Left Side and 0" on Top or 5/8" (16-mm) on Left Side and 2" (5-cm) on Top	6" (15-cm)	2" (5-cm)

B. Checks Before Installation

<i>NOTICE</i>
<ul style="list-style-type: none">• Remove all shipping cartons, tape, and packing material. If any are left in the appliance, it will not work properly.• Remove the shipping tape holding the door and the bin control actuator.

- Remove all shipping cartons, tape, and packing material. If any are left in the appliance, it will not work properly.
 - Remove the shipping tape holding the door and the bin control actuator.
-
- Visually inspect the exterior of the shipping container and immediately report any damage to the carrier. Upon opening the container, any concealed damage should also be immediately reported to the carrier.
 - Remove the package containing the accessories.
 - Remove the shipping carton, tape, and packing material. If any are left in the appliance, it will not work properly.
 - Remove the protective plastic film from the panels. If the appliance is exposed to the sun or to heat, remove the film after the appliance cools.
 - Check that refrigerant lines do not rub or touch lines or other surfaces, and that the fan blade turns freely.
 - Check that the compressor is snug on all mounting pads.
 - See the nameplate on the rear panel and check that your voltage supplied corresponds with the voltage specified on the nameplate.

C. How to Remove Panels

See Fig. 1

- Top Panel: Remove the screws and lift up.
- Top Insulation: Lift up.
- Top Sheet: Lift up.
- Front Panel: Remove the screw and pull towards you.
- Right Side Panel: Remove the screws (front and rear) and slide right slightly.
- Front Frame: Loosen the screws. Lift up and pull towards you.
- Front Sheet: Lift up and pull towards you.

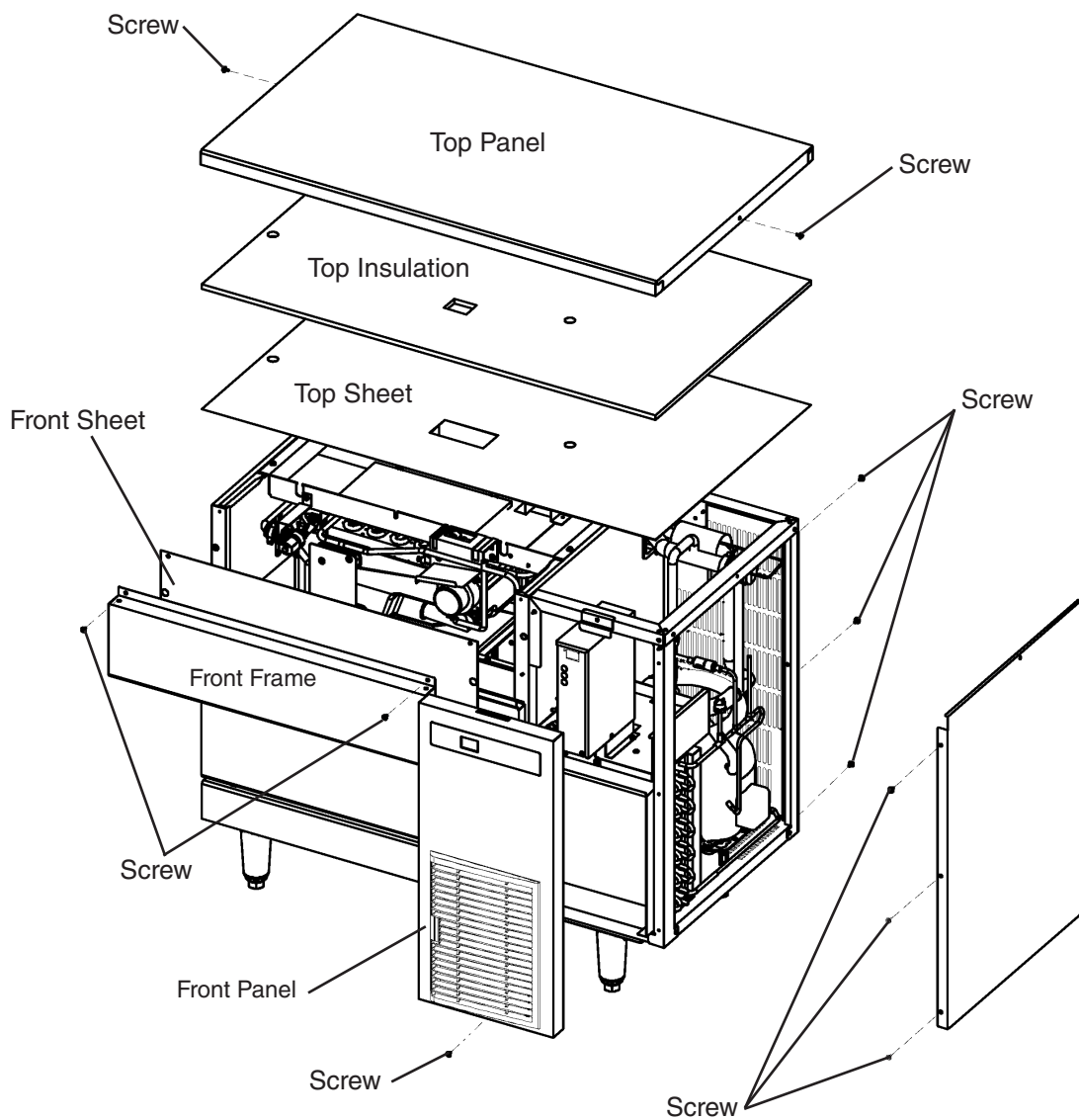

Fig. 1

D. Setup

NOTICE

- Do not place more than 33 lb. (15 kg) on the top panel.
- Do not use the frame to lift the appliance. Lift the appliance from the base.
- Handle the appliance carefully to avoid damaging the exterior.

- 1) Attach the five adjustable legs provided to the bottom of the appliance.
- 2) Position the appliance in its permanent location.
- 3) Level the appliance from side-to-side and front-to-rear by adjusting the legs.

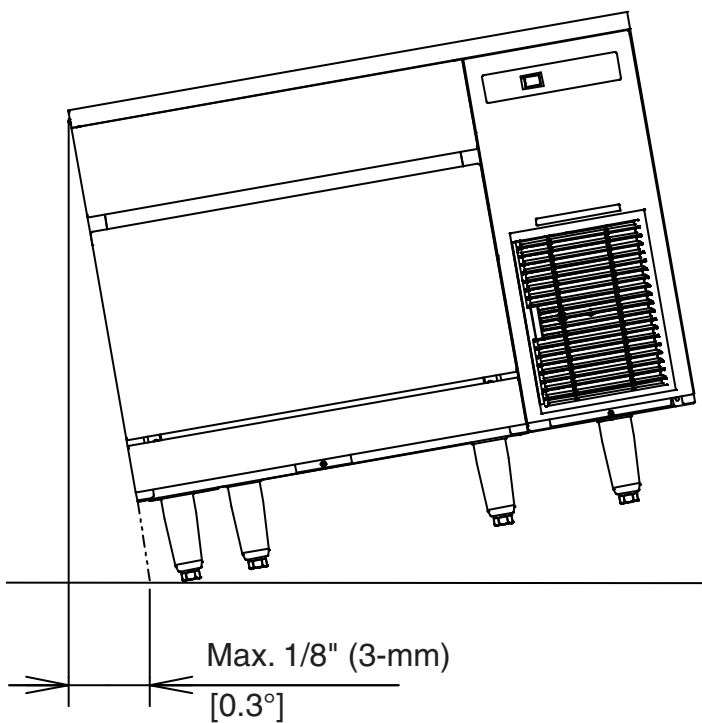

Fig. 2

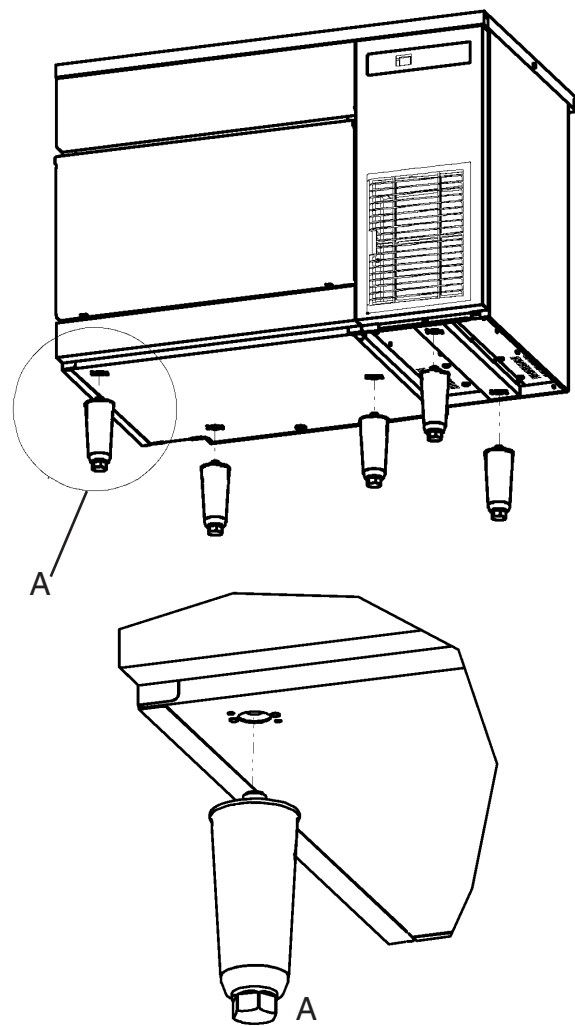

Fig. 3

E. Electrical Connection

WARNING

- Electrical connection must meet national, state, and local electrical code requirements. Failure to meet these code requirements could result in death, electric shock, serious injury, fire, or damage.
 - The appliance requires an independent power supply of proper capacity. See the nameplate for electrical specifications. Failure to use an independent power supply of proper capacity can result in a tripped breaker, blown fuse, damage to existing wiring, or component failure. This could lead to heat generation or fire.
 - **THE ICEMAKER MUST BE GROUNDED:** The appliance is equipped with a NEMA 5-15 three-prong grounding plug to reduce the risk of potential shock hazards. It must be plugged into a properly grounded, independent 3-prong wall outlet. If the outlet is a 2-prong outlet, it is your personal responsibility to have a qualified electrician replace it with a properly grounded, independent 3-prong wall outlet. Do not remove the ground prong from the plug and do not use an adapter plug. Failure to properly ground the appliance could result in death or serious injury.
 - Do not use an extension cord.
 - To reduce the risk of electric shock, do not touch the control switch or plug with damp hands. Make sure the control switch is in the "OFF" position before plugging in or unplugging the appliance.
 - Do not use an appliance with a damaged power cord. The power cord should not be altered, jerked, bundled, weighed down, pinched, or tangled. Such actions could result in electric shock or fire. To unplug the appliance, be sure to pull the plug, not the cord, and do not jerk the cord.
 - If the supply cord is damaged, it must be replaced by the manufacturer, its service agent, or similarly qualified persons in order to avoid a hazard. Upon replacement, the GREEN ground wire in the power cord must be connected to the designated grounding screw.
-
- Usually an electrical permit and services of a licensed electrician are required.
 - The maximum allowable voltage variation is ± 6 percent of the nameplate rating.

F. Water Supply and Drain Connections

See Fig. 4

⚠ WARNING

- Water supply and drain connections must be installed in accordance with applicable national, state, and local regulations.
- Connect to potable water supply only. Do not connect to a hot-water supply.

NOTICE

- Water supply line size is critical to the operation of the appliance. Failure to provide adequate water supply to the appliance may result in damage to the appliance, damage to property, and may void the warranty.
- Normal operating water temperature should be within 45°F to 90°F (7°C to 32°C). Operation of the appliance, for extended periods, outside of this normal temperature range may affect appliance performance.
- Water supply pressure must be a minimum of 10 PSIG (68 kPaG) and a maximum of 113 PSIG (779 kPaG). If the pressure exceeds 113 PSIG (779 kPaG), the use of a pressure reducing valve is required.
- External filters, strainers, or softeners may be required depending on water quality. Contact your local Hoshizaki Certified Service Representative or local Hoshizaki distributor for recommendations.
- In areas where water damage is a concern, install in a contained area with a floor drain.
- Water line installation to the appliance is not warranted by Hoshizaki.
- Be sure there is sufficient extra water supply line and drain line for the appliance to be pulled out for service.
- Water-hammer issues must be resolved by a qualified plumber before installing the appliance. Water hammer can cause appliance damage that may lead to water leakage or flooding.
- A minimum of 3/4" nominal ID hard pipe or equivalent is required for the drain line. Installing a smaller diameter drain line will reduce water flow and may lead to water leakage or flooding.
- To prevent damage to the appliance, do not operate the appliance when the water supply is off, or if the pressure is below 10 PSIG (68 kPaG). Do not run the appliance until the proper water pressure is reached.

- A plumbing permit and services of a licensed plumber may be required in some areas.
- Drain lines must have 1/4" fall per foot (2-cm per 1-m) on horizontal runs to get a good flow. A vented tee connection is also required for proper flow.
- Drain lines should not be piped directly to the sewer system. An air gap of a minimum of 2 vertical inches (5-cm) should be between the end of the drain pipes from the icemaker/ice storage bin and water-cooled condenser (if applicable) and the floor drain.

1. Icemaker

Icemaker Water Supply Inlet	Minimum Icemaker Water Supply Line Size	Icemaker / Ice Storage Bin Drain Outlet	Minimum Icemaker Drain Line Size
1/2" Female Pipe Thread (FPT)	1/4" Nominal ID Copper Water Tubing or Equivalent	3/4" Female Pipe Thread (FPT)	3/4" Nominal ID Hard Pipe or Equivalent

- An icemaker water supply line shut-off valve and drain valve must be installed.

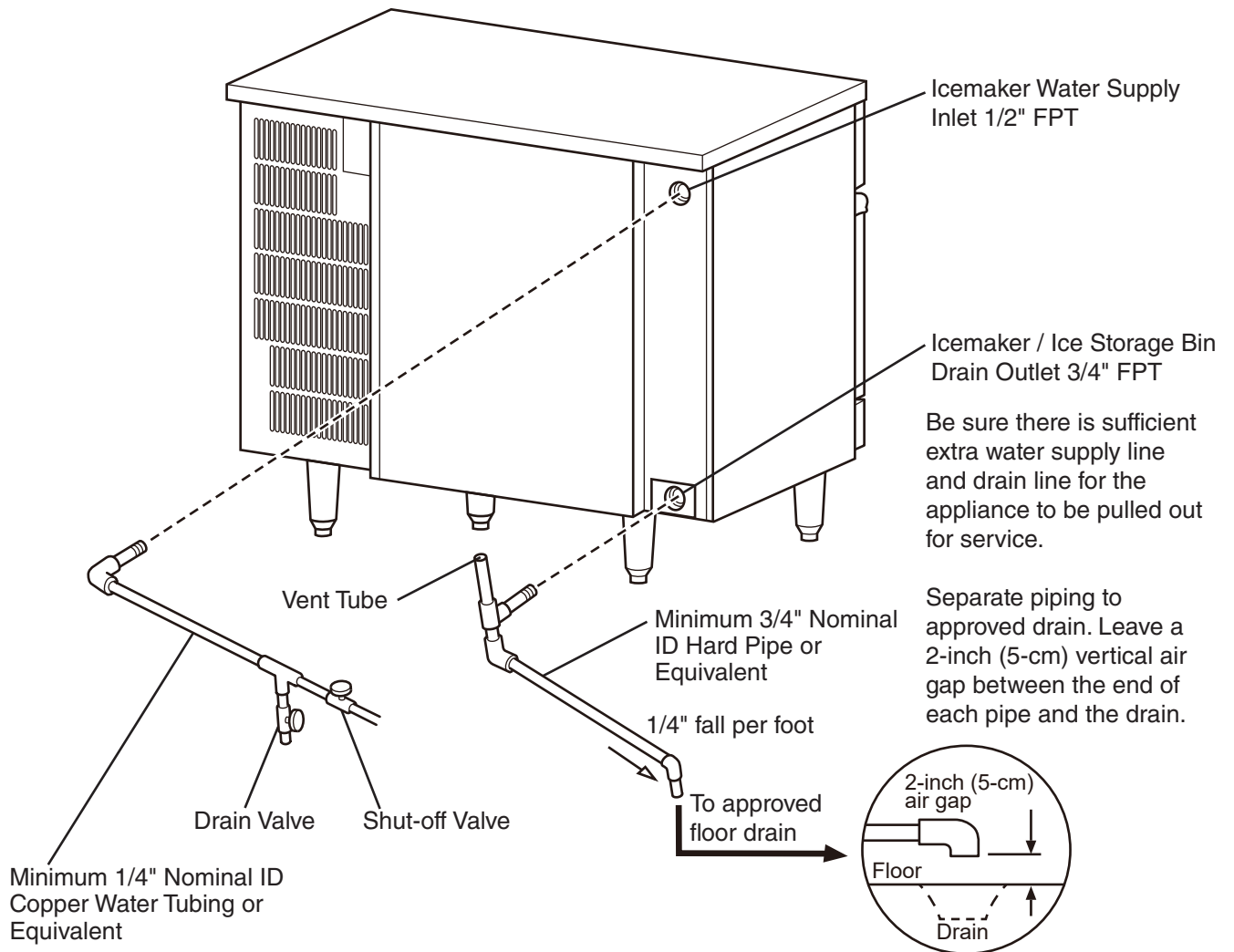

Fig. 4

G. Final Checklist

1. Pre-Startup

- 1) Is the appliance level?
- 2) Is the appliance in a site where the ambient temperature is within 45°F to 100°F (7°C to 38°C) and the water temperature within 45°F to 90°F (7°C to 32°C) all year around?
- 3) Have the minimum clearance requirements specified below been met?

Left Side and Top	Right Side	Rear
2" (5-cm) on Left Side and 0" on Top or 5/8" (16-mm) on Left Side and 2" (5-cm) on Top	6" (15-cm)	2" (5-cm)

- 4) Have all shipping cartons, tape, and packing material been removed from the appliance?
- 5) Have all electrical and water connections been made? Do electrical and water connections meet applicable national, state, and local code and regulation requirements?
- 6) Has the power supply voltage been checked or tested against the nameplate rating? Is the power supply a properly grounded, independent 3-prong wall outlet?
- 7) Are the water supply and drain lines sized as specified? Are the water supply line shut-off valve(s) and drain valve(s) installed? Has the water supply pressure been checked to ensure a minimum of 10 PSIG (68.9 kPa) and a maximum of 113 PSIG (779.1 kPa)?
- 8) Is the compressor snug on all mounting pads? Have the refrigerant lines been checked to make sure they do not rub or touch other lines or surfaces? Has the fan blade (if applicable) been checked to make sure it turns freely?
- 9) Continue to "III. Operating Instructions."

2. Post-Startup

⚠ WARNING
CHOKING HAZARD: Ensure all components, fasteners, and thumbscrews are securely in place after installation. Make sure that none have fallen into the ice storage bin.

- 1) Has the bin control operation been confirmed?
- 2) Are all components, fasteners, and thumbscrews securely in place?
- 3) Has the end user been given the instruction manual, and instructed on how to operate the appliance and the importance of the recommended periodic maintenance?
- 4) Has the end user been given the contact information of an authorized service agent?
- 5) Has the warranty card been filled out and forwarded to the factory for warranty registration?

III. Operating Instructions



R-290 Class A3 Flammable Refrigerant Used

⚠ DANGER

Risk of Fire or Explosion. Flammable Refrigerant Used.

- Be sure to follow all Important Safety Information located at the beginning of this manual.
- Failure to install, operate, and maintain the appliance in accordance with this manual will adversely affect safety, performance, component life, and warranty coverage and may result in costly water damage.
- Keep clear of obstruction all ventilation openings in the appliance enclosure or in the structure for building-in.

Risque D'Incendie ou D'Explosion. Fluide Frigorigène Inflammable Utilisé.

- Veuillez à respecter toutes les consignes de sécurité importantes figurant au début de ce manuel.
- Le fait de ne pas installer, utiliser et entretenir l'appareil conformément à ce manuel aura des conséquences négatives sur la sécurité, les performances, la durée de vie des composants et la couverture de la garantie, et peut entraîner des dégâts des eaux coûteux.
- Ne pas obstruer les ouvertures de ventilation dans l'enceinte de l'appareil ou dans la structure d'encastrement.

A. Important Notes About Usage

NOTICE

- Protect the floor when moving the appliance to prevent damage to the floor.
- If water collects in the bin and will not drain, turn off the appliance and close the water supply line shut-off valve. Call for service.
- Do not leave the appliance on during extended periods of non-use, extended absences, or in sub-freezing temperatures. To properly prepare the appliance for these occasions, follow the instructions in "V. Preparing the Appliance for Periods of Non-Use."
- Do not place objects on top of the appliance.
- The ice storage bin is for ice use only. Do not store anything else in the ice storage bin.

B. Startup and Bin Control Check

WARNING

- All parts are factory-adjusted. Improper adjustments may adversely affect safety, performance, component life, and warranty coverage.
- To reduce the risk of electric shock, do not touch the power switch, control switch, or plug (on corded models) with damp hands. If you have to slide the appliance back for a built-in installation, make sure you do not damage or pinch the water supply line, drain line, or power cord.

NOTICE

- If the appliance is turned off, wait for at least 3 minutes before restarting the appliance to prevent damage to the compressor.
- To prevent damage to the water pump, do not leave the control switch in the "WASH" position for extended periods of time when the water tank is empty.

- 1) Open the door.
- 2) Clean the ice storage bin using a neutral cleaner. Rinse thoroughly after cleaning.
- 3) Close the door.
- 4) Open the water supply line shut-off valve.
- 5) Remove the front panel.
- 6) Make sure the control switch is in the "OFF" position. Plug the appliance into the electrical outlet. **WARNING! To reduce the risk of electric shock, do not touch the control switch or plug with damp hands.**
- 7) Move the control switch to the "ICE" position.
- 8) Allow the icemaker to cycle on.
- 9) Confirm bin control operation: In the initial harvest cycle, as the water pan starts dropping, press and hold the bin control's actuator paddle (open). Continue holding the bin control actuator paddle until the appliance shuts down. Release the bin control actuator paddle.
Restart: 80 sec. after the bin control actuator paddle is released (closed), the automatic icemaking process restarts.
- 10) Replace the front panel in its correct position.
- 11) Return to "II.G.2. Post-Startup.

C. Control Board Display

1. Normal Operation

Display for normal operation is "on". See the figure on the right.



2. Error Code

The control board will show an error code and safely stop if the appliance is operating outside of acceptable parameters. See the figure below. If an error code appears, please contact your local Hoshizaki Certified Service Representative for assistance.

- E1: Abnormal freeze cycle
- E2: Abnormal harvest cycle
- EE: Other



IV. Maintenance

The appliance must be maintained in accordance with the instruction manual and labels provided with the appliance. Consult with your local Hoshizaki Certified Service Representative about maintenance service. To obtain the name and phone number of your local Hoshizaki Certified Service Representative, visit www.hoshizakiamerica.com.

WARNING

- Items listed under "IV.A. User Maintenance Schedule" may be performed by the user; otherwise, only qualified service technicians should service the appliance.
- Failure to install, operate, and maintain the equipment in accordance with this manual will adversely affect safety, performance, component life, and warranty coverage.
- To reduce the risk of electric shock, do not touch the control switch or plug with damp hands. Make sure the control switch is in the "OFF" position before plugging in or unplugging the appliance.
- **Before Performing Maintenance/Service:** Move the control switch to the "OFF" position, then unplug the appliance from the electrical outlet.
- **CHOKING HAZARD:** Ensure all components, fasteners, and thumbscrews are securely in place after any maintenance is done to the appliance. Make sure that none have fallen into the ice storage bin.
- After service, make sure that there are no wires pinched between the panels and appliance. Make sure you do not damage or pinch the water supply line, drain line, or power cord.

A. User Maintenance Schedule

The user maintenance schedule below is a guideline. More frequent maintenance may be required depending on water quality, the appliance's environment, and local sanitation regulations.

Maintenance Schedule		
Frequency	Area	Task
Daily	Scoop	Clean the ice scoop using a neutral cleaner. Rinse thoroughly after cleaning.
Bi-Weekly	Air Filters	Inspect. Wash with warm water and neutral cleaner if dirty.
Monthly	Appliance Exterior	Wipe down with a clean, soft cloth. Use a damp cloth containing a neutral cleaner to wipe off oil or dirt build up. Clean any chlorine staining (rust colored spots) using a non-abrasive cleanser.

B. Service Maintenance Schedule

The service maintenance schedule below is a guideline; service maintenance items are to be performed by qualified service technicians only. More frequent maintenance may be required depending on water quality, the appliance's environment, and local sanitation regulations.

Maintenance Schedule		
Frequency	Area	Task
Monthly	External Water Filters	Check for proper pressure and change if necessary.
Yearly	Icemaker and Ice Storage Bin Liner	Clean and sanitize per the cleaning and sanitizing instructions provided in this manual or on the maintenance label on the icemaker.
	Water Supply Inlet	Close the icemaker water supply line shut-off valve and drain the water system. Clean the water supply inlet screen.
	Condenser	Inspect. Clean if necessary by using a brush or vacuum cleaner. More frequent cleaning may be required depending on location.
	Water Hoses	Inspect the water hoses and clean/replace if necessary.
	Appliance	Inspect for oil spots, loose components, fasteners, and wires.

C. Cleaning and Sanitizing Instructions

The appliance must be cleaned and sanitized at least once a year. More frequent cleaning and sanitizing may be required in some water conditions.

⚠ WARNING
<ul style="list-style-type: none">• To prevent injury to individuals and damage to the appliance, do not use ammonia type cleaners.• Carefully follow any instructions provided with the bottles of cleaning and sanitizing solution.• Always wear liquid-proof gloves and goggles to prevent the cleaning and sanitizing solutions from coming into contact with skin or eyes.• After cleaning and sanitizing, be careful not to leave any solution in the appliance.

NOTICE
To prevent damage to the water pump, do not leave the control switch in the "WASH" position for extended periods of time when the water tank is empty.

1. Cleaning Procedure

- 1) Dilute 3 fl. oz. (88.7 ml) of Hoshizaki "Scale Away" with 0.5 gallon (1.9 l) of warm water. **IMPORTANT! For safety and maximum effectiveness, use the solution immediately after dilution.**
- 2) Remove the front panel and then move the control switch to the "OFF" position. Unplug the appliance.
- 3) Remove all ice from the ice storage bin.
- 4) Remove the top panel, top insulation, top sheet, front frame, and front sheet.

- 5) Remove the screw and then move the water tank drain pipe to the drain position. See Fig. 5. Use the screw to secure the water tank drain pipe in the drain position.

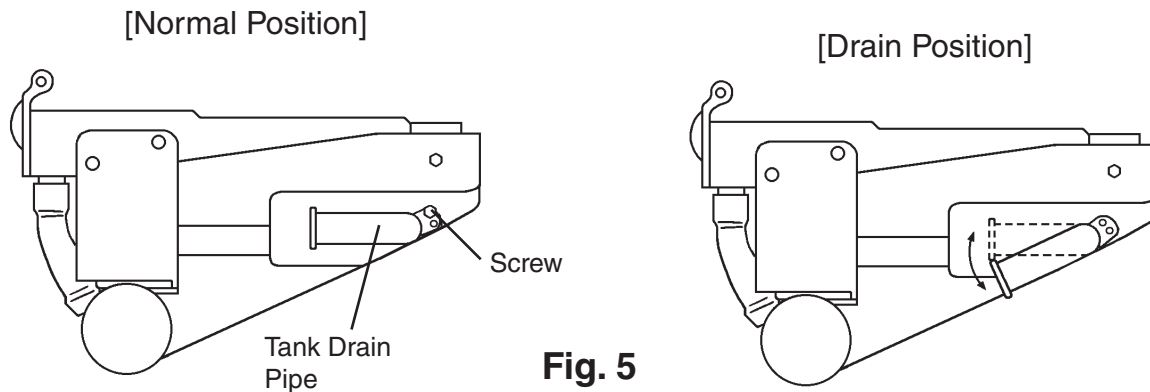

- 6) Replace the front sheet, front frame, top sheet, top insulation, and top panel.
- 7) Close the icemaker water supply line shut-off valve.
- 8) Plug in the appliance. Move the control switch to the "ICE" position and then replace the front panel.
- 9) Allow the appliance to operate for 3 minutes; the water tank drains and cubes are removed from the evaporator.
- 10) Remove the front panel and then move the control switch to the "OFF" position. Unplug the appliance.
- 11) Remove the top panel, top insulation, and top sheet.
- 12) Slowly pour the cleaning solution over the top of the evaporator and into the water tank. Do not splash or spill the solution onto other parts.
- 13) Replace the top sheet, top insulation, and top panel.
- 14) Plug in the appliance. Move the control switch to the "WASH" position to start the cleaning process and then replace the front panel.
- 15) After 30 minutes, remove the front panel and then move the control switch to the "OFF" position. Unplug the appliance.
- 16) Open the icemaker water supply line shut-off valve.
- 17) Plug in the appliance. Move the control switch to the "ICE" position and then replace the front panel.
- 18) Allow the appliance to operate for 3 minutes to drain the water tank, and then remove the front panel.
- 19) Move the control switch to the "OFF" position. After 5 seconds, move the control switch to the "ICE" position and then replace the front panel.
- 20) Repeat steps 18 and 19 three more times to rise thoroughly.
Note: If not sanitizing the icemaker, go to step 18 in "IV.C.2. Sanitizing Procedure - Following Cleaning Procedure."

2. Sanitizing Procedure - Following Cleaning Procedure

- 1) Dilute 0.17 fl. oz. (5.05 ml) of a 7.5% sodium hypochlorite solution (chlorine bleach) with 0.5 gal. (1.9 l) of warm water. **IMPORTANT! For safety and maximum effectiveness, use the solution immediately after dilution.**
- 2) Remove the front panel and then move the control switch to the "OFF" position. Unplug the appliance.
- 3) Close the icemaker water supply line shut-off valve.
- 4) Plug in the appliance and then move the control switch to the "ICE" position. Replace the front panel.
- 5) Allow the appliance to operate for 3 minutes to drain the water tank.
- 6) Remove the front panel and then move the control switch to the "OFF" position. Unplug the appliance.
- 7) Remove the top panel, top insulation, and top sheet.
- 8) Slowly pour the sanitizing solution over the top of the evaporator and into the water tank. Do not splash or spill the solution onto the other parts.
- 9) Replace the top sheet, top insulation, and top panel.
- 10) Plug in the appliance. Move the control switch to the "WASH" position to start the sanitizing process and then replace the front panel.
- 11) After 15 minutes, remove the front panel and then move the control switch to the "OFF" position. Unplug the appliance.
- 12) Open the icemaker water supply line shut-off valve.
- 13) Plug in the appliance. Move the control switch to the "ICE" position and then replace the front panel.
- 14) Allow the appliance to operate for 3 minutes to drain the water tank and then remove the front panel.
- 15) Move the control switch to the "OFF" position. After 5 seconds, move the control switch to the "ICE" position and then replace the front panel.
- 16) Repeat steps 14 and 15 three more times to rise thoroughly.
- 17) Repeat steps 1 through 16 one more time.
- 18) Remove the front panel and then move the control switch to the "OFF" position. Unplug the appliance.
- 19) Remove the top panel, top insulation, top sheet, front frame, and front sheet.
- 20) Remove the screw and then move the water tank drain pipe to the normal position. See Fig. 5. Use the screw to secure the water tank drain pipe in the normal position.
- 21) Replace the front sheet, front frame, top sheet, top insulation, and top panel.
- 22) Clean the ice storage bin liner using a neutral cleaner. Rinse thoroughly after cleaning.
- 23) Plug in the appliance. Move the control switch to the "ICE" position and then replace the front panel to start the automatic icemaking process.

3. Bin Control Cleaning

Scale may build up on the bin control. Scale can cause the actuator paddle and magnet to stick. In this case, the bin control should be cleaned.

⚠ WARNING

CHOKING HAZARD: Ensure all components, fasteners, and thumbscrews are securely in place after the icemaker is serviced. Make sure that none have fallen into the dispense unit/ice storage bin.

- 1) Turn off the power supply.
- 2) Remove the front panel, then move the control switch to the "OFF" position.
- 3) Clear any ice away from the bin control actuator paddle.
- 4) Carefully remove the bin control cable from the cable ties in the evaporator case, then remove the bin control from the bin control bracket and move to the front of the icemaker for cleaning.
- 5) Remove the actuator paddle from the switch mount. See Fig. 6.
- 6) Wipe down the bin control with a mixture of 1 part of Hoshizaki "Scale Away" and 25 parts of warm water. Rinse the parts thoroughly with clean water.
- 7) Reassemble the bin control and replace it in its correct position.
Note: If the magnet was removed for cleaning, be sure to replace it in its correct position.
- 8) Replace the bin control cable into the cable ties in the evaporator case, then move the control switch to the "ICE" position.
- 9) Turn on the power supply to start the automatic icemaking process.
- 10) Replace the front panel in its correct position.

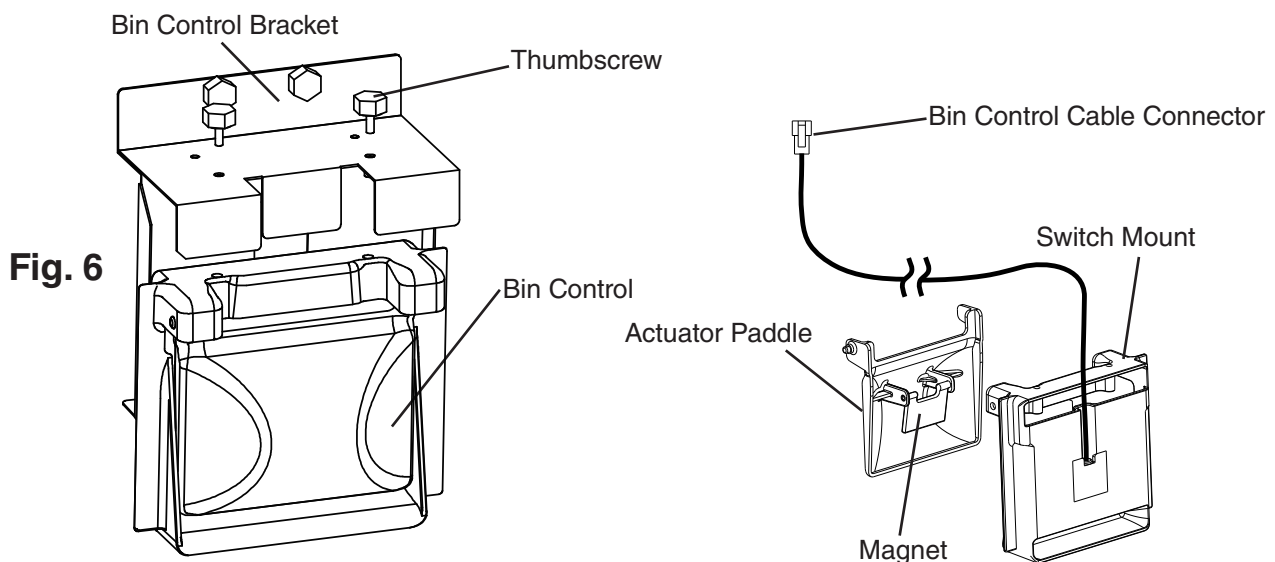

V. Preparing the Appliance for Periods of Non-Use

⚠ WARNING

Only qualified service technicians should service this appliance.

<i>NOTICE</i>

- | |
|---|
| <ul style="list-style-type: none">• During extended periods of non-use, extended absences, or in sub-freezing temperatures, follow the instructions below to reduce the risk of costly water damage.• When the appliance is not used for two or three days under normal conditions, it is sufficient to move the control switch to the "OFF" position.• To prevent damage to the water pump seal, do not leave the control switch in the "WASH" position for extended periods when the water tank is empty. |
|---|

1. Remove the water from the icemaker water supply line:

- 1) Remove the front panel.
- 2) Move the control switch to the "OFF" position.
- 3) Close the icemaker water supply line shut-off valve and then open the icemaker water supply line drain valve. See Fig. 4.
- 4) Allow the icemaker water supply line to drain by gravity.
- 5) Attach compressed air or carbon dioxide supply to the icemaker water supply line drain valve.
- 6) Move the control switch to the "ICE" position.
- 7) Blow the icemaker water supply line out using compressed air or carbon dioxide.

2. Drain the water tank:

- 1) Move the control switch to the "OFF" position and then unplug the appliance.
- 2) Remove the top panel, top insulation, and top sheet.
- 3) Remove the screw and then move the tank drain pipe to the drain position. See Fig. 7.
- 4) Replace the top sheet, top insulation, and top panel.
- 5) Close the icemaker water supply line drain valve.
- 6) Plug in the appliance and then move the control switch to the "ICE" position.
- 7) Press the "RESET" button. See Fig. 8. The water tank will start to open.

Note: This procedure is necessary to protect the appliance from freezing up at sub-freezing temperatures.

- 8) Move the control switch to the "OFF" position and then unplug the appliance when the water tank is fully opened.
- 9) Remove the top panel, top insulation, and top sheet.
- 10) Move the tank drain pipe to the normal position and then secure it with the screw. See Fig. 7.
- 11) Replace the top sheet, top insulation, top panel, and front panel.

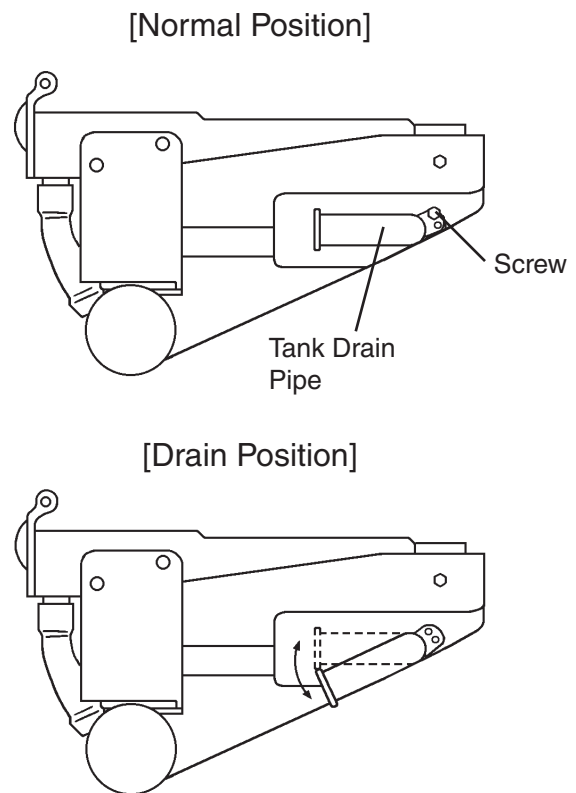

Fig. 7

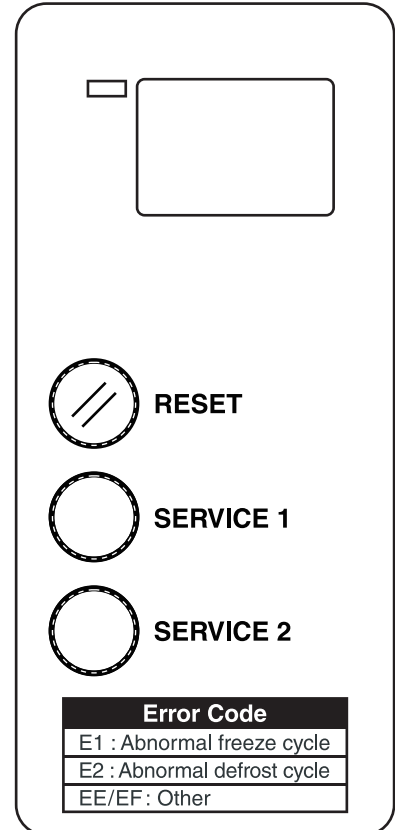

Fig. 8

VI. Decommissioning and Disposal



R-290 Class A3 Flammable Refrigerant Used

⚠ DANGER

Risk of Fire or Explosion. Flammable Refrigerant Used.

- Only qualified service technicians should install and service the appliance.
- Follow handling instructions carefully in compliance with national regulations.
- Dispose of properly in accordance with federal or local regulations.
- Do not puncture refrigerant tubing. Risk of fire or explosion due to puncture of refrigerant tubing; follow handling instructions carefully.
- Be sure to follow the full Decommissioning and Disposal information located in the Service Manual for this model. The Service Manual is available at www.hoshizakiamerica.com.

Risque D'Incendie ou D'Explosion. Fluide Frigorigène Inflammable Utilisé.

- Seuls des techniciens de service qualifiés doivent installer et entretenir l'appareil.
- Suivre attentivement les instructions de manutention conformément aux règlements nationaux.
- Mettre au rebut conformément aux conformément aux règlements fédéraux ou locaux.
- Ne pas perforer la tubulure contenant le frigorigène. Risque de feu ou d'explosion si la tubulure contenant le frigorigène est perforée; suivre les instructions de manutention avec soin.
- Veiller à respecter l'ensemble des informations relatives à la mise hors service et à la mise au rebut figurant dans le manuel d'entretien de ce modèle. Le manuel d'entretien est disponible à l'adresse suivante: www.hoshizakiamerica.com.

HOSHIZAKI AMERICA, INC.

618 Hwy. 74 S., Peachtree City, GA 30269 USA | TEL (770) 487-2331 | FAX (770) 487-3360 | www.hoshizaki.com | 1A8203-010