



# HOSHIZAKI

## Service Manual

Self-Contained Cuber

Models

IM-200BAK



[hoshizakiamerica.com](http://hoshizakiamerica.com)

Number: 73265  
Issued: 9-25-2025  
Revised: 12-4-2025

**⚠ WARNING**

Only qualified service technicians should install and service the appliance. To obtain the name and phone number of your local Hoshizaki Certified Service Representative, visit [www.hoshizakiamerica.com](http://www.hoshizakiamerica.com). No service should be undertaken until the technician has thoroughly read this Service Manual. Failure to service and maintain the appliance in accordance with this manual will adversely affect safety, performance, component life, and warranty coverage. Proper installation is the responsibility of the installer. Product failure or property damage due to improper installation is not covered under warranty.

Hoshizaki provides this manual primarily to assist qualified service technicians in the service of the appliance.

Should the reader have any questions or concerns which have not been satisfactorily addressed, please call, send an e-mail message, or write to the Hoshizaki Technical Support Department for assistance.

Phone: 1-800-233-1940; (770) 487-2331

E-mail: [tech-support@hoshizaki.com](mailto:tech-support@hoshizaki.com)

**HOSHIZAKI AMERICA, INC.**

618 Highway 74 South

Peachtree City, GA 30269

Attn: Hoshizaki Technical Support Department

**NOTE:** To expedite assistance, all correspondence/communication **MUST** include the following information:

- Model Number \_\_\_\_\_
- Serial Number \_\_\_\_\_
- Complete and detailed explanation of the problem.

## **IMPORTANT**

This manual should be read carefully before the appliance is serviced. Read the warnings and guidelines contained in this manual carefully as they provide essential information for the continued safe use, service, and maintenance of the appliance. Retain this manual for any further reference that may be necessary.

## **CONTENTS**

Important Safety Information .....	4
I. Construction and Water/Refrigeration Circuit Diagram .....	9
A. Construction .....	9
B. Water/Refrigeration Circuit Diagram .....	11
II. Sequence of Operation .....	12
A. Sequence of Operation Flow Chart .....	12
1. Icemaker Flow Chart .....	12
2. Bin Control Shutdown Flow Chart .....	13
III. Service Diagnosis, Refrigeration Circuit Service, and Component Service .....	14
A. Safety Precautions When Servicing   Précautions à prendre lors de l'entretien .....	14
1. English .....	14
2. Français .....	19
B. Service Diagnosis .....	24
C. Control Board Check .....	29
D. Bin Control Check .....	30
E. Evaporator Thermistor Check .....	32
F. Control Switch .....	32
G. Diagnosis Table .....	33
H. Freeze-Up Check List .....	36
IV. Controls and Adjustments .....	37
A. Control Board .....	37
B. Control Board Buttons .....	39
C. Control Board Settings .....	40
D. Control Board Information Display .....	44
E. Control Board Model Code Setting .....	46
F. Error Codes .....	47
G. Quick Adjustments .....	49
H. Refrigeration Circuit Service .....	51
I. Component Service Information .....	56
V. Maintenance .....	58
VI. Preparing the Appliance for Periods of Non-Use .....	59
VII. Decommissioning and Disposal .....	61
VIII. Technical Information .....	65
A. Specification and Performance Data Sheets .....	65
B. Wiring Diagram .....	66

## Important Safety Information

Throughout this manual, notices appear to bring your attention to situations which could result in death, serious injury, damage to the appliance, or damage to property.

	<b>R-290 Class A3 Flammable Refrigerant Used</b>
<b>! DANGER</b>	Indicates a hazardous situation that, if not avoided, will result in death or serious injury.
<b>! WARNING</b>	Indicates a hazardous situation that, if not avoided, could result in death or serious injury.
<b>NOTICE</b>	Indicates a situation that, if not avoided, could result in damage to the appliance or property.
<b>IMPORTANT</b>	Indicates important information about the use and care of the appliance.

### **! DANGER**

#### **Risk of Fire or Explosion** **Flammable Refrigerant Used**

- Only qualified service technicians should install and service the appliance. Qualified service technicians are those having the appropriate technical training and experience necessary to be aware of hazards to which they are exposed in performing a task and of measures necessary to minimize the danger to themselves or other persons.
- No service should be undertaken until the technician has thoroughly read this Service Manual. All safety precautions must be followed.
- This appliance to be installed in accordance with the Safety Standard for Refrigeration Systems ANSI/ASHRAE 15.
- Follow handling instructions carefully in compliance with national regulations.
- Do not use mechanical devices or other means to accelerate the defrosting process or to clean, other than those recommended by the manufacturer.
- Do not puncture refrigerant tubing. Risk of fire or explosion due to puncture of refrigerant tubing; follow handling instructions carefully.

- Servicing shall be done by trained service personnel with certified competence in handling flammable refrigerants to minimize the risk of possible ignition due to incorrect parts or improper service.
- Component parts shall be replaced with like components. So as to minimize the risk of possible ignition due to incorrect parts.
- Dispose of properly in accordance with federal or local regulations.
- Do not pierce or burn.
- Be aware that refrigerants may not contain an odor.
- Do not damage the refrigeration circuit.
- See nameplate for R-290 refrigerant charge:
  - If greater than 114 g (4 oz.), do not install in public corridor or lobby.
  - If greater than 152 g (5.3 oz.), do not install within 6 m (20 ft) of open flame.
- The appliance shall be stored in a room without continuously operating ignition sources (for example: open flames, an operating gas appliance, or an operating electric heater).

## **! DANGER continued**

- Do not place any potential ignition sources in or near the appliance.
- Keep clear of obstruction all ventilation openings in the appliance enclosure or in the structure for building-in.
- No potential sources of ignition are to be used in the searching for or detection of refrigerant leaks.
- Do not use electrical appliances inside the appliance unless they are of the type recommended by the manufacturer.
- Do not store explosive substances such as aerosol cans with a flammable propellant in this appliance.
- Check that cabling will not be subject to wear, corrosion, excessive pressure, vibration, sharp edges, or any other adverse environmental effects. The check shall also take into account the effects of aging or continual vibration from sources such as compressors or fans.
- Ensure that the area is in the open or that it is adequately ventilated before breaking into the system or conducting any hot work. A degree of ventilation shall continue during the period that the work is carried out. The ventilation should safely disperse any released refrigerant and preferably expel it externally into the atmosphere.

### **Risque D'Incendie ou D'Explosion Fluide Frigorigène Inflammable Utilisé**

- Seuls des techniciens de service qualifiés doivent installer et entretenir l'appareil. Les techniciens de service qualifiés sont ceux qui possèdent la formation technique et l'expérience nécessaires pour être conscients des dangers auxquels ils sont exposés dans l'accomplissement d'une tâche et des mesures nécessaires pour réduire au minimum le danger pour eux-mêmes ou pour d'autres personnes.
- Aucune opération d'entretien ne doit être entreprise avant que le technicien n'ait lu attentivement ce manuel. Toutes les précautions de sécurité doivent être suivies.
- Cet appareil doit être installé conformément à la norme de sécurité pour les systèmes de réfrigération ANSI/ASHRAE 15.
- Suivez attentivement les instructions de manutention conformément aux règlements nationaux.
- Ne pas utiliser de dispositifs mécaniques ou d'autres moyens pour accélérer le processus de dégivrage ou pour nettoyer, autres que ceux recommandés par le fabricant.
- Ne pas perforer la conduite de fluide frigorigène. Risque d'incendie ou d'explosion en cas de perforation d'une canalisation de fluide frigorigène; suivez attentivement les instructions de manutention.
- L'entretien doit être effectué par du personnel formé et certifié pour la manipulation de réfrigérants inflammables afin de réduire au minimum le risque d'inflammation dû à des pièces incorrectes ou à un entretien inadéquat.
- Les pièces doivent être remplacées par des pièces similaires, de manière à réduire au minimum le risque d'inflammation dû à des pièces incorrectes.

## **! DANGER Continué**

- Mettre au rebut conformément aux règlements fédéraux ou locaux.
- Ne pas percer ou brûler.
- Attention, les fluides frigorigènes peuvent ne pas dégager d'odeur.
- Ne pas endommager les composants du circuit de réfrigération.
- Voir plaque signalétique pour la charge de réfrigérant R-290:
  - Si elle est supérieure à 114 g (4 oz.), ne pas l'installer dans un couloir public ou un hall d'entrée.
  - Si elle est supérieure à 152 g (5,3 oz.), ne pas l'installer à moins de 6 m (20 pi) d'une flamme nue.
- L'appareil doit être entreposé dans un local ne contenant pas de sources d'inflammation permanentes (flammes nues, appareil à gaz ou dispositif de chauffage électrique en fonctionnement, par exemple).
- Ne placer aucune source d'inflammation potentielle à l'intérieur ou à proximité de l'appareil.
- Ne pas obstruer les ouvertures de ventilation dans l'enceinte de l'appareil ou dans la structure d'encastrement.
- Aucune source potentielle d'inflammation ne doit être utilisée pour rechercher ou détecter des fuites de réfrigérant.
- Ne pas utiliser d'appareils électriques à l'intérieur de l'appareil, sauf s'ils sont du type recommandé par le fabricant.
- Ne pas entreposer dans cet appareil des substances explosives telles que des bombes aérosols contenant un gaz propulseur inflammable.
- Vérifier que le câblage ne sera pas soumis à l'usure, à la corrosion, à une pression excessive, à des vibrations, à des arêtes vives ou à tout autre effet environnemental négatif. Le contrôle doit également prendre en compte les effets du vieillissement ou des vibrations continues provenant de sources telles que les compresseurs ou les ventilateurs.
- S'assurer que la zone est à l'air libre ou qu'elle est correctement ventilée avant de pénétrer dans le système ou d'effectuer un travail à chaud. Une certaine ventilation doit être maintenue pendant la durée des travaux. La ventilation doit permettre de disperser en toute sécurité tout réfrigérant libéré et, de préférence, de l'expulser dans l'atmosphère.

## **⚠ WARNING**

The appliance should be destined only to the use for which it has been expressly conceived. Any other use should be considered improper and therefore dangerous. The manufacturer cannot be held responsible for injury or damage resulting from improper, incorrect, and unreasonable use. Failure to service and maintain the appliance in accordance with this manual will adversely affect safety, performance, component life, and warranty coverage and may result in costly water damage.

**To reduce the risk of death, electric shock, serious injury, or fire, follow basic precautions including the following:**

- This appliance is not intended for use above 2,000 m (6,561 ft). Installation above 2,000 m (6,561 ft) may adversely affect safety, performance, and component life.
- Wear appropriate personal protective equipment (PPE) when servicing the appliance.
- The appliance must be installed in accordance with applicable national, state, and local codes and regulations. Failure to meet these code requirements could result in death, electric shock, serious injury, fire, or damage.
- The appliance requires an independent power supply of proper capacity. See the nameplate for electrical specifications. Failure to use an independent power supply of proper capacity can result in a tripped breaker, blown fuse, damage to existing wiring, or component failure. This could lead to heat generation or fire.
- **THE APPLIANCE MUST BE GROUNDED.** The appliance is equipped with a NEMA 5-15 three-prong grounding plug  to reduce the risk of potential shock hazards. It must be plugged into a properly grounded, independent 3-prong wall outlet. If the outlet is a 2-prong outlet, it is your personal responsibility to have a qualified electrician replace it with a properly grounded, independent 3-prong wall outlet. Do not remove the ground prong from the power cord and do not use an adapter plug. Failure to follow these instructions may result in death, electric shock, or fire.
- To reduce the risk of electric shock, do not touch the control switch or plug with damp hands.
- To reduce the risk of electric shock, make sure the control switch is in the "OFF" position before plugging in or unplugging the appliance.
- Unplug the appliance before servicing.
- Do not use an appliance with a damaged power cord. The power cord should not be altered, jerked, bundled, weighed down, pinched, or tangled. Such actions could result in electric shock or fire. To unplug the appliance, be sure to pull the plug, not the cord, and do not jerk the cord.
- Do not use an extension cord.
- If the supply cord is damaged, it must be replaced by the manufacturer, its service agent, or similarly qualified persons in order to avoid a hazard. Upon replacement, the GREEN ground wire in the power cord must be connected to the designated grounding screw.
- Do not make any alterations to the appliance. Alterations could result in electric shock, injury, fire, or damage to the appliance.
- Appliance is heavy. Use care when lifting or positioning. Work in pairs when needed to prevent injury or damage.

**⚠ WARNING continued**

- The appliance is not intended for use by persons (including children) with reduced physical, sensory, or mental capabilities, or lack of experience and knowledge, unless they have been given supervision or instruction concerning use of the appliance by a person responsible for their safety.
- Do not splash, pour, or spray water directly onto or into the appliance. This might cause short circuit, electric shock, corrosion, or failure.
- Children should be supervised to ensure that they do not play with the appliance.
- Do not climb, stand, or hang on the appliance or drawers or allow children or animals to do so. Do not climb into the appliance or allow children or animals to do so. Death or serious injury could occur or the appliance could be damaged.
- Open and close the door with care. Door opened too quickly or forcefully may cause injury or damage to the appliance or surrounding equipment.
- Be careful not to pinch fingers when opening and closing the door. Be careful when opening and closing the door when children are in the area.
- Do not use combustible spray or place volatile or flammable substances in or near the appliance. They might catch fire.
- Keep the area around the appliance clean. Dirt, dust, or insects in the appliance could cause harm to individuals or damage to the appliance.

**NOTICE**

- Follow the water supply, drain connection, and maintenance instructions in the instruction manual carefully to reduce the risk of costly water damage.
- In areas where water damage is a concern, install in a contained area with a floor drain.
- Install the appliance in a location that stays above freezing. Normal operating ambient temperature must be within 45°F to 100°F (7°C to 38°C).
- Do not leave the appliance on during extended periods of non-use, extended absences, or in sub-freezing temperatures. To properly prepare the appliance for these occasions, follow the instructions in "VI. Preparing the Appliance for Periods of Non-Use."
- If water collects in the bin and will not drain, turn off the appliance and close the water supply line shut-off valve.
- If water seeps from the base of the appliance, turn off the appliance and close the water supply line shut-off valve. Failure to do so could lead to costly water damage.
- Do not place objects on top of the appliance.
- The ice storage bin is for ice use only. Do not store anything else in the ice storage bin.
- Protect the floor when moving the appliance to prevent damage to the floor.
- Do not allow the appliance to bear any outside weight.

---

# I. Construction and Water/Refrigeration Circuit Diagram

## A. Construction

### 1. Air-Cooled Model (BAK)

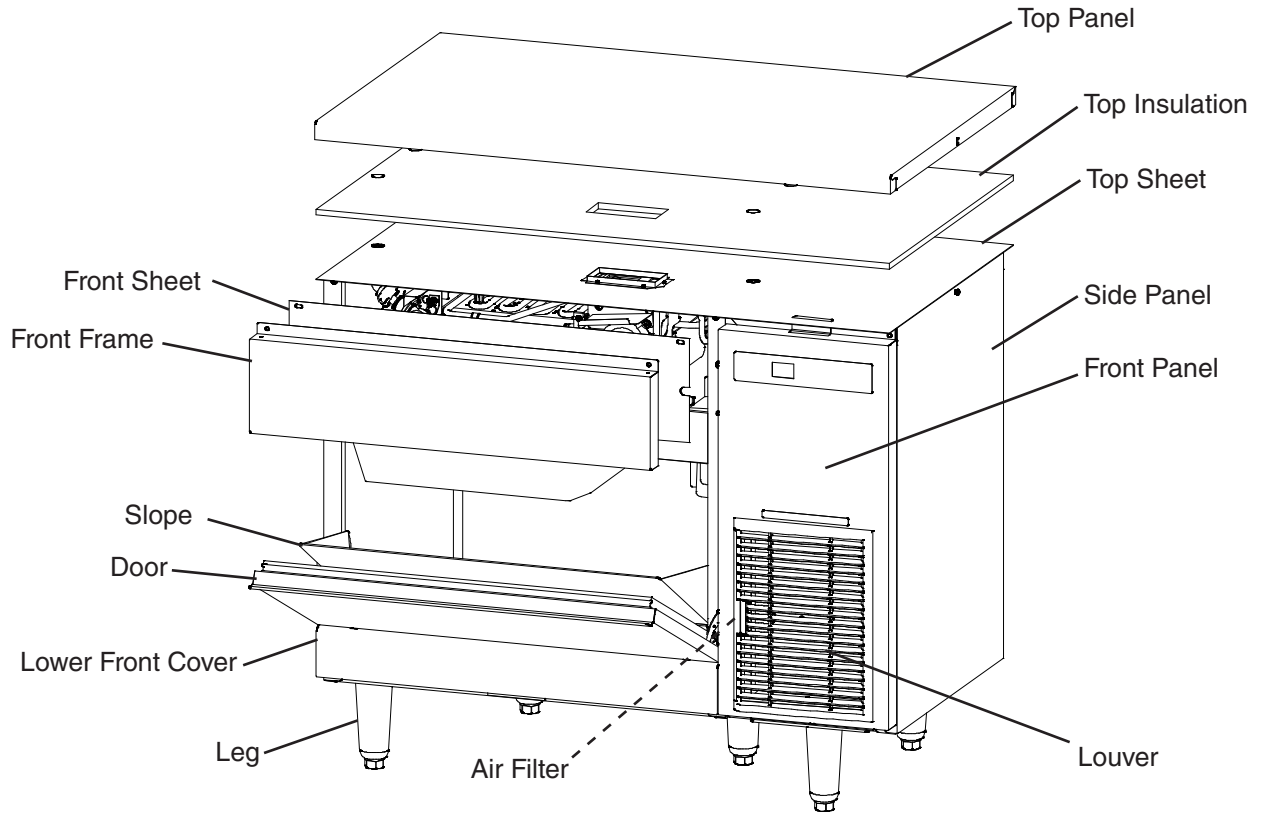

Front View (Outside)

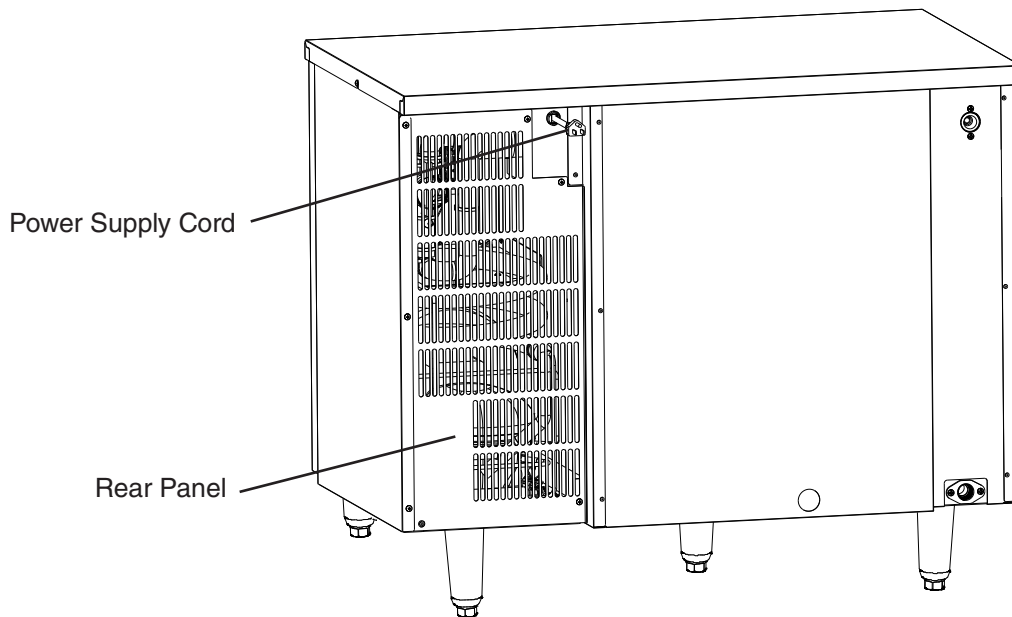

Rear View (Outside)

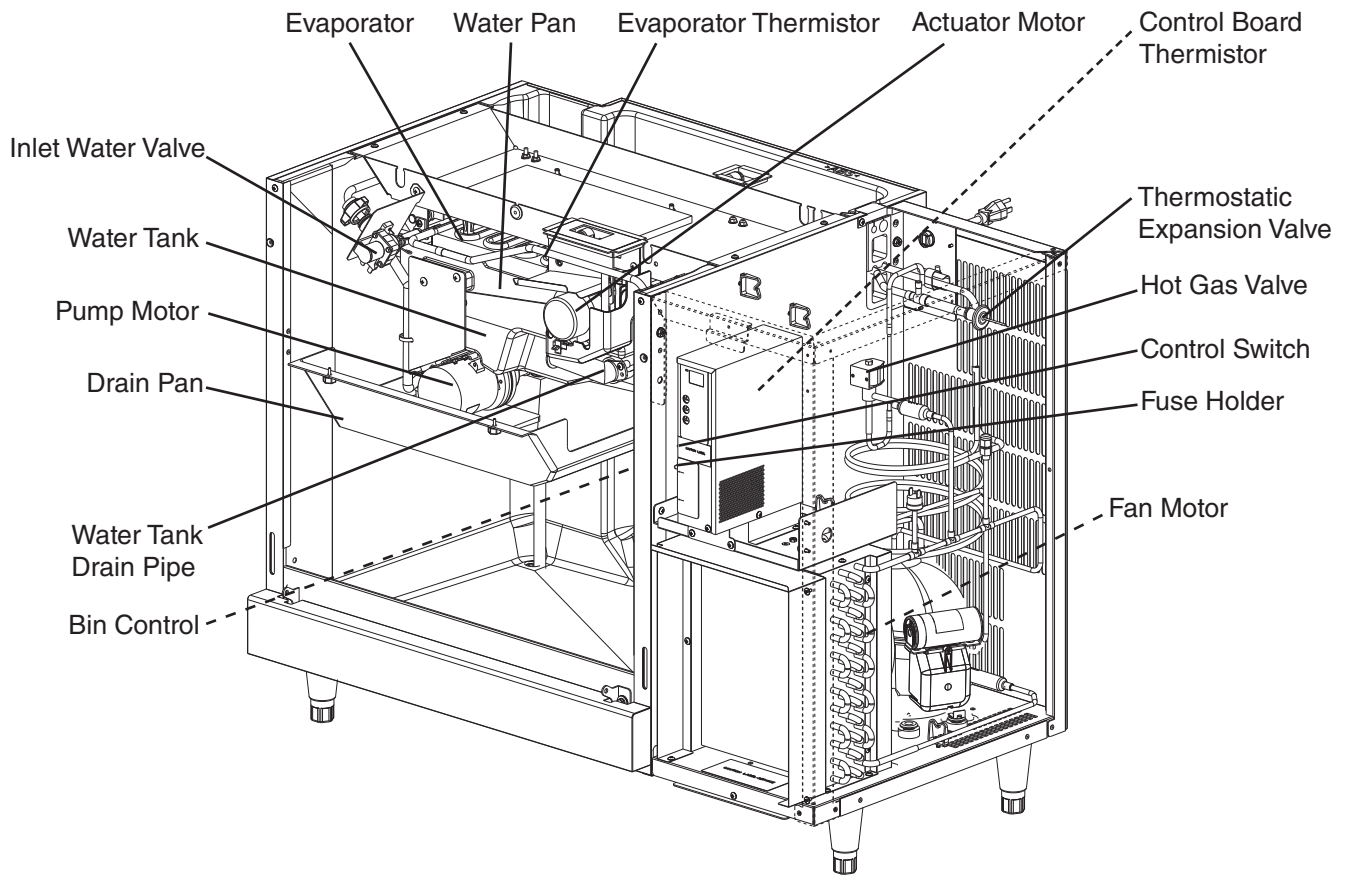

**Front View (Inside)**

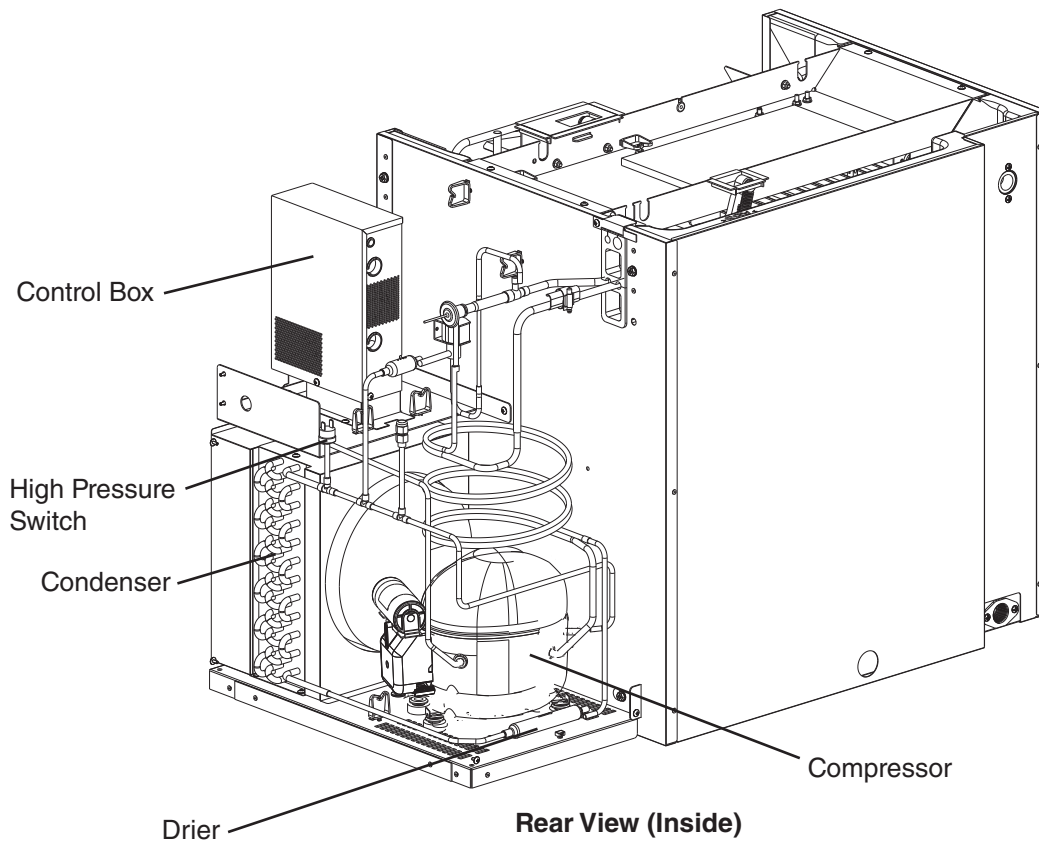

**Rear View (Inside)**

## B. Water/Refrigeration Circuit Diagram

### 1. Air-Cooled Model (BAK)

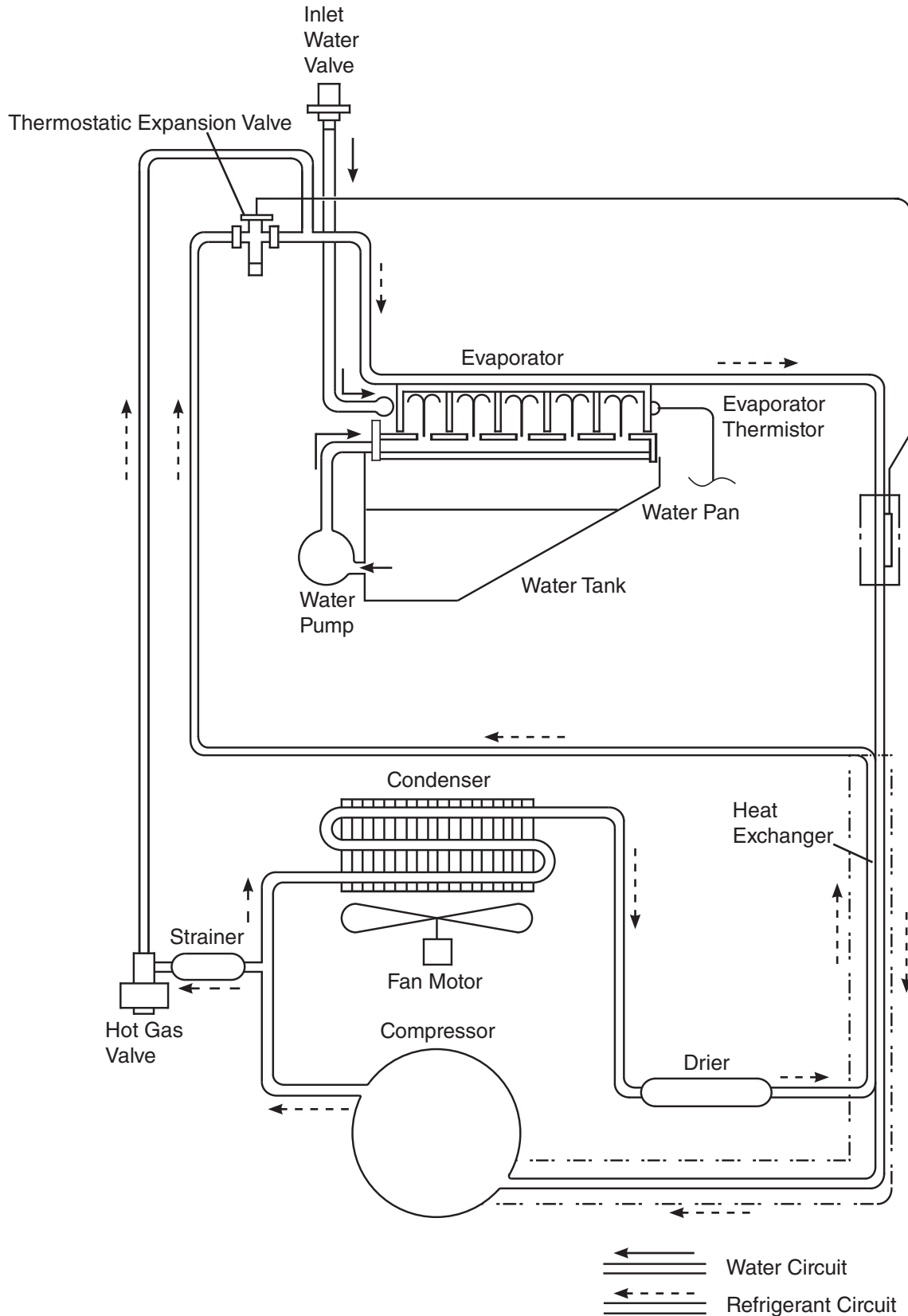

## II. Sequence of Operation

### A. Sequence of Operation Flow Chart

#### 1. Icemaker Flow Chart

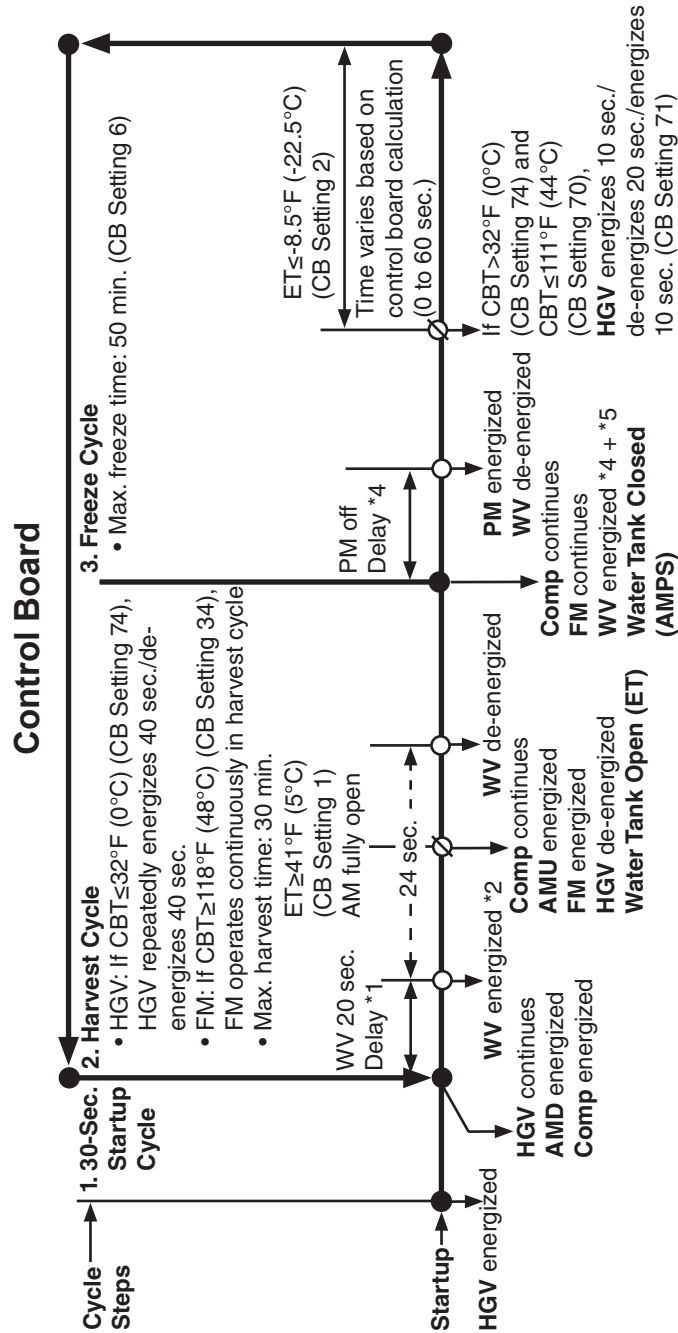

Legend:	
AMD	actuator motor down
AMPS	actuator motor position sensor
AMU	actuator motor up
BC	bin control
CBT	control board thermistor
Comp	compressor
ET	evaporator thermistor
FD	full drain (CB Setting 14)
FM	fan motor
HGV	hot gas valve
PD	partial drain (CB Setting 14)
PM	pump motor
WPA	water pan assembly
WT	water temperature
WV	inlet water valve

## 2. Bin Control Shutdown Flow Chart

### Shutdown and Restart Sequence Flow Chart

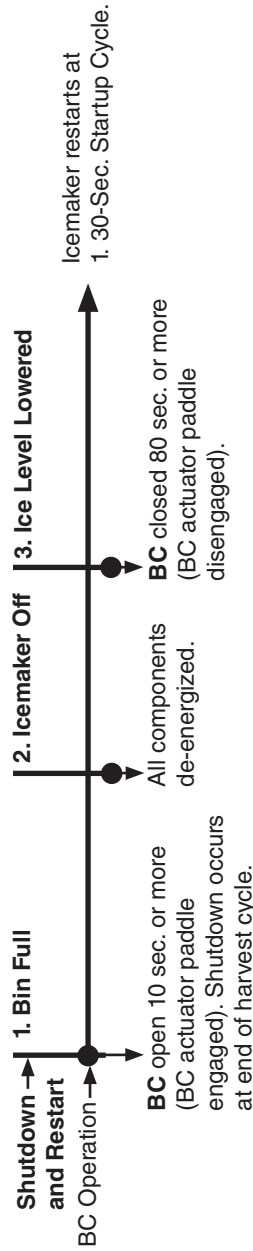

Note	CB Setting	Initial Harvest and Initial Freeze after Power On	Initial Harvest and Initial Freeze after Bin Control Initiated Restart	Normal Harvest and Freeze
*1	NA	All WT 20 sec.	WT > 48°F (9°C) 0 sec.	WT > 48°F (9°C) 20 sec.
*2	10	WT < 48°F (9°C) 98 sec.	10 sec.	24 sec.
	11	WT > 48°F (9°C) 24 sec.	24 sec.	24 sec.
*3	NA	10 sec.	10 sec.	10 sec.
PD*4	12	37 sec. x 2	37 sec. x 2	37 sec.
PD*5	15	0 sec.	0 sec.	0 sec.
FD*4	12	74 sec.	74 sec.	74 sec.
FD*5	15	0 sec.	0 sec.	0 sec.
			WT ≤ 48°F (9°C)	WT ≤ 48°F (9°C)
			WT > 48°F (9°C)	WT > 48°F (9°C)
			WT ≤ 48°F (9°C)	WT ≤ 48°F (9°C)

Legend:	
AMD	actuator motor down
AMPS	actuator motor position sensor
AMU	actuator motor up
BC	bin control
CBT	control board thermistor
Comp	compressor
ET	evaporator thermistor
FD	full drain (CB Setting 14)
FM	fan motor
HGV	hot gas valve
PD	partial drain (CB Setting 14)
PM	pump motor
WPA	water pan assembly
WT	water temperature
WV	inlet water valve

### III. Service Diagnosis, Refrigeration Circuit Service, and Component Service

#### A. Safety Precautions When Servicing | Précautions à prendre lors de l'entretien

##### 1. English



#### R-290 Class A3 Flammable Refrigerant Used

### **! DANGER**

#### **Risk of Fire or Explosion. Flammable Refrigerant Used.**

- Be sure to follow all Important Safety Information located at the beginning of this manual and in this section.
- The appliance should be diagnosed and repaired only by qualified service personnel to reduce the risk of death, electric shock, serious injury, or fire.
- Servicing shall be done by trained service personnel with certified competence in handling flammable refrigerants to minimize the risk of possible ignition due to incorrect parts or improper service.
- Follow handling instructions carefully in compliance with national regulations.
- Do not use mechanical devices or other means to accelerate the defrosting process or to clean, other than those recommended by the manufacturer.
- Be aware that refrigerants may not contain an odor.
- Do not puncture refrigerant tubing. Risk of fire or explosion due to puncture of refrigerant tubing; follow handling instructions carefully.
- Component parts shall be replaced with like components. So as to minimize the risk of possible ignition due to incorrect parts.
- Do not place any potential ignition sources in or near the appliance.
- Prior to beginning work on systems containing flammable refrigerants, safety checks are necessary to ensure that the risk of ignition is minimized.
- All maintenance staff and others working in the local area shall be instructed on the nature of work being carried out. Work in confined spaces shall be avoided.
- Work shall be undertaken under a controlled procedure so as to minimize the risk of a flammable gas or vapor being present while the work is being performed.
- The area shall be checked with an appropriate refrigerant detector prior to and during work, to ensure the technician is aware of potentially toxic or flammable atmospheres.
- Ensure that the leak detection equipment being used is suitable for use with all applicable refrigerants, i.e., nonsparking, adequately sealed, or intrinsically safe.  
NOTE: The use of silicone sealant can inhibit the effectiveness of some types of leak detection equipment.
- Under no circumstances shall potential sources of ignition be used in the searching for or detection of refrigerant leaks. A halide torch (or any other detector using a naked flame) shall not be used.

## **! DANGER continued**

- The following leak detection methods are deemed acceptable for all refrigerant systems:
  - Electronic leak detectors may be used to detect refrigerant leaks but, in the case of flammable refrigerants, the sensitivity might not be adequate, or might need recalibration. (Detection equipment shall be calibrated in a refrigerant-free area.) Ensure that the detector is not a potential source of ignition and is suitable for the refrigerant used. Leak detection equipment shall be set at a percentage of the LFL of the refrigerant and shall be calibrated to the refrigerant employed, and the appropriate percentage of gas (25% maximum) is confirmed.
  - Leak detection fluids are also suitable for use with most refrigerants but the use of detergents containing chlorine shall be avoided as the chlorine can react with the refrigerant and corrode the copper pipe-work.  
Note: Examples of leak detection fluids are:
    - bubble method
    - fluorescent method agents
- If any hot work is to be conducted on the refrigerating equipment or any associated parts, appropriate fire extinguishing equipment shall be available on hand. A dry chemical or CO<sub>2</sub> fire extinguisher should be adjacent to the charging area. You must have a Class B chemical fire extinguisher available at all times.
- No person carrying out work in relation to a refrigerating system which involves exposing any pipe work shall use any sources of ignition in such a manner that it may lead to the risk of fire or explosion. All possible ignition sources, including cigarette smoking, should be kept sufficiently far away from the site of installation, repairing, removing, and disposal, during which refrigerant can possibly be released to the surrounding space. Prior to work taking place, the area around the equipment shall be surveyed to make sure that there are no flammable hazards or ignition risks. “No Smoking” signs shall be displayed.
- Ensure that the area is in the open or that it is adequately ventilated before breaking into the system or conducting any hot work. A degree of ventilation shall continue during the period that the work is carried out. The ventilation should safely disperse any released refrigerant and preferably expel it externally into the atmosphere.
- When breaking into the refrigerant circuit to make repairs – or for any other purpose – conventional procedures shall be used. However, for flammable refrigerants it is important that best practice be followed, since flammability is a consideration. The following procedure shall be adhered to:
  - safely remove refrigerant following local and national regulations
  - purge the circuit with inert gas
  - evacuate (optional for A2L)
  - purge with inert gas (optional for A2L)
  - open the circuit by cutting or brazing
- If a leak is suspected, all naked flames shall be removed/extinguished.
- If a leakage of refrigerant is found which requires brazing, all of the refrigerant shall be recovered from the system, or isolated (by means of shut off valves) in a part of the system remote from the leak.

## **! DANGER continued**

- When removing refrigerant from a system, either for servicing or decommissioning, it is recommended good practice that all refrigerants are removed safely.
- When transferring refrigerant into cylinders, ensure that only appropriate refrigerant recovery cylinders are employed. Ensure that the correct number of cylinders for holding the total system charge is available. All cylinders to be used are designated for the recovered refrigerant and labeled for that refrigerant (i.e., special cylinders for the recovery of refrigerant). Cylinders shall be complete with pressure-relief valve and associated shut-off valves in good working order. Empty recovery cylinders are evacuated and, if possible, cooled before recovery occurs.
- The recovery equipment shall be in good working order with a set of instructions concerning the equipment that is at hand and shall be suitable for the recovery of all appropriate refrigerants including, when applicable, flammable refrigerants. In addition, a set of calibrated weighing scales shall be available and in good working order. Hoses shall be complete with leak-free disconnect couplings and in good condition. Before using the recovery machine, check that it is in satisfactory working order, has been properly maintained and that any associated electrical components are sealed to prevent ignition in the event of a refrigerant release. Consult manufacturer if in doubt.
- The recovered refrigerant shall be returned to the refrigerant supplier in the correct recovery cylinder, and the relevant waste transfer note arranged. Do not mix refrigerants in recovery units and especially not in cylinders.
- If compressors or compressor oils are to be removed, ensure that they have been evacuated to an acceptable level to make certain that flammable refrigerant does not remain within the lubricant. The evacuation process shall be carried out prior to returning the compressor to the suppliers. Only electric heating to the compressor body shall be employed to accelerate this process. When oil is drained from a system, it shall be carried out safely.
- In addition to conventional charging procedures, the following requirements shall be followed:
  - Ensure that contamination of different refrigerants does not occur when using charging equipment. Hoses or lines shall be as short as possible to minimize the amount of refrigerant contained in them.
  - Cylinders shall be kept in an appropriate position according to the instructions.
  - Ensure that the refrigerating system is earthed (grounded) prior to charging the system with refrigerant.
  - Label the system when charging is complete (if not already).
  - Extreme care shall be taken not to overfill the refrigerating system.
- Prior to recharging the system, it shall be pressure-tested with the appropriate purging gas. The system shall be leak-tested on completion of charging but prior to commissioning. A follow up leak test shall be carried out prior to leaving the site.

## **⚠ DANGER continued**

- Repair and maintenance to electrical components shall include initial safety checks and component inspection procedures. If a fault exists that could compromise safety, then no electrical supply shall be connected to the circuit until it is satisfactorily dealt with. If the fault cannot be corrected immediately but it is necessary to continue operation, an adequate temporary solution shall be used. This shall be reported to the owner of the equipment, so all parties are advised.
- Confirm that capacitors are discharged: this shall be done in a safe manner to avoid possibility of sparking.
- Confirm that no live electrical components and wiring are exposed while charging, recovering, or purging the system.
- Confirm that there is continuity of earth bonding (grounding).
- During repairs to sealed components, all electrical supplies shall be disconnected from the equipment being worked upon prior to any removal of sealed covers, etc. If it is absolutely necessary to have an electrical supply to equipment during servicing, then a permanently operating form of leak detection shall be located at the most critical point to warn of a potentially hazardous situation.
- Where electrical components are being changed, they shall be fit for the purpose and to the correct specification. At all times, Hoshizaki America's maintenance and service guidelines shall be followed. If in doubt, consult Hoshizaki America's Technical Support department for assistance.
- Confirm the actual refrigerant charge is in accordance with the room size within which the refrigerant containing parts are installed.
- Confirm the ventilation machinery and outlets are operating adequately and are not obstructed.
- Confirm marking to the equipment continues to be visible and legible. Markings and signs that are illegible shall be corrected.
- Confirm refrigerating pipe or components are installed in a position where they are unlikely to be exposed to any substance which may corrode refrigerant containing components, unless the components are constructed of materials which are inherently resistant to being corroded or are suitably protected against being so corroded.
- Particular attention shall be paid to the following to ensure that by working on electrical components, the casing is not altered in such a way that the level of protection is affected. This shall include damage to cables, excessive number of connections, terminals not made to original specification, damage to seals, incorrect fitting of glands, etc.
- Ensure that the apparatus (control box/component) is mounted securely.
- Ensure that seals or sealing materials have not degraded to the point that they no longer serve the purpose of preventing the ingress of flammable atmospheres. Replacement parts shall be in accordance with Hoshizaki America's specifications.
- Do not apply any permanent inductive or capacitance loads to the circuit without ensuring that this will not exceed the permissible voltage and current permitted for the equipment in use.

## **! DANGER continued**

- Intrinsically safe components are the only types that can be worked on while live in the presence of a flammable atmosphere. The test apparatus shall be at the correct rating.
- Replace components only with parts specified by Hoshizaki America. Other parts can result in the ignition of refrigerant in the atmosphere from a leak.
- Check that cabling will not be subject to wear, corrosion, excessive pressure, vibration, sharp edges, or any other adverse environmental effects. The check shall also take into account the effects of aging or continual vibration from sources such as compressors or fans.

## 2. Français



### R-290 Classe A3 Réfrigérant Inflammable Utilisé

#### **! DANGER**

#### **Risque De Feu Ou D'Explosion. Fluide Frigorigène Inflammable Utilisé.**

- Assurez-vous de suivre toutes les informations importantes de sécurité situées au début de ce manuel et dans cette section.
- L'appareil ne doit être diagnostiqué et réparé que par un personnel qualifié afin de prévenir les risques de mort, d'électrocution, de blessures graves ou d'incendie.
- L'entretien doit être effectué par du personnel formé et certifié pour la manipulation de réfrigérants inflammables afin de réduire au minimum le risque d'inflammation dû à des pièces incorrectes ou à un entretien inadéquat.
- Suivez attentivement les instructions de manutention conformément aux règlements nationaux.
- Ne pas utiliser de dispositifs mécaniques ou d'autres moyens pour accélérer le processus de dégivrage ou pour nettoyer, autres que ceux recommandés par le fabricant.
- Attention, les fluides frigorigènes peuvent ne pas dégager d'odeur.
- Ne pas perforer la tubulure contenant le frigorigène. Risque de feu ou d'explosion si la tubulure contenant le frigorigène est perforée; suivre les instructions de manutention avec soin.
- Les pièces doivent être remplacées par des pièces similaires, de manière à réduire au minimum le risque d'inflammation dû à des pièces incorrectes.
- Ne placez aucune source d'inflammation potentielle dans ou près de l'appareil.
- Avant de commencer à travailler sur des systèmes contenant des réfrigérants inflammables, des contrôles de sécurité sont nécessaires pour s'assurer que le risque d'inflammation est minimisé.
- Tout le personnel d'entretien et les autres personnes travaillant dans la zone locale doivent être informés de la nature des travaux effectués. Les travaux dans des espaces confinés doivent être évités.
- Les travaux doivent être entrepris selon une procédure contrôlée afin de minimiser le risque de présence de gaz ou de vapeur inflammable pendant l'exécution des travaux.
- La zone doit être contrôlée à l'aide d'un détecteur de réfrigérant approprié avant et pendant les travaux, afin de s'assurer que le technicien est conscient de l'existence d'atmosphères potentiellement toxiques ou inflammables.
- Assurez-vous que l'équipement de détection des fuites utilisé est adapté à l'utilisation de tous les réfrigérants applicables, c'est-à-dire qu'il ne produit pas d'étincelles, qu'il est correctement scellé ou qu'il est intrinsèquement sûr. REMARQUE: L'utilisation de mastic silicone peut réduire l'efficacité de certains types d'équipements de détection des fuites.
- En aucun cas, des sources potentielles d'inflammation ne doivent être utilisées pour rechercher ou détecter des fuites de réfrigérant. Une lampe haloïde (ou tout autre détecteur utilisant une flamme nue) ne doit pas être utilisée.

## **! DANGER Continué**

- Les méthodes de détection de fuite suivantes sont considérées comme acceptables pour tous les systèmes de réfrigération:
  - Des détecteurs de fuites électroniques peuvent être utilisés pour détecter les fuites de réfrigérants, mais, dans le cas de réfrigérants inflammables, la sensibilité pourrait ne pas être adéquate ou nécessiter un réétalonnage. (L'équipement de détection doit être étalonné dans une zone sans réfrigérant.) Assurez-vous que le détecteur n'est pas une source potentielle d'inflammation et qu'il est adapté au réfrigérant utilisé. L'équipement de détection des fuites doit être réglé sur un pourcentage de la LII du réfrigérant et doit être étalonné en fonction du réfrigérant utilisé, et le pourcentage approprié de gaz (25% au maximum) est confirmé.
  - Les liquides de détection des fuites conviennent également à la plupart des réfrigérants, mais l'utilisation de détergents contenant du chlore doit être évitée, car le chlore peut réagir avec le réfrigérant et corroder la tuyauterie en cuivre.  
Remarque : Voici quelques exemples de liquides de détection de fuites :
    - méthode des bulles
    - agents de méthode fluorescents
- Si un travail à chaud doit être effectué sur l'équipement réfrigérant ou toute partie associée, un équipement d'extinction d'incendie approprié doit être disponible. Un extincteur à poudre chimique ou à CO<sub>2</sub> devrait être installé à proximité de la zone de chargement. Un extincteur chimique de classe B doit être disponible à tout moment.
- Il est interdit à toute personne effectuant des travaux en rapport avec un système réfrigérant qui impliquent la mise à nu d'une tuyauterie d'utiliser des sources d'inflammation de manière à entraîner un risque d'incendie ou d'explosion. Toutes les sources d'inflammation possibles, y compris la cigarette, doivent être suffisamment éloignées du site d'installation, de réparation, d'enlèvement et d'élimination, au cours desquels du réfrigérant peut éventuellement être libéré dans l'espace environnant. Avant d'entamer les travaux, la zone autour de l'équipement doit être étudiée pour s'assurer qu'il n'y a aucun risque d'inflammabilité ou d'inflammation. Des panneaux «Interdiction de fumer» doivent être affichés.
- Assurez-vous que la zone est à l'air libre ou qu'elle est correctement ventilée avant de pénétrer dans le système ou d'effectuer un travail à chaud. Un certain degré de ventilation doit être maintenu pendant la période où les travaux sont effectués. La ventilation doit permettre de disperser en toute sécurité tout réfrigérant libéré et, de préférence, de l'expulser dans l'atmosphère.
- Pour pénétrer dans le circuit du réfrigérant afin d'effectuer des réparations ou pour toute autre raison, des procédures conventionnelles doivent être utilisées. Toutefois, pour les réfrigérants inflammables, il est important de suivre les meilleures pratiques, car l'inflammabilité est un facteur à prendre en considération. La procédure suivante doit être respectée:
  - éliminer le réfrigérant en toute sécurité conformément aux réglementations locales et nationales
  - purger le circuit avec du gaz inerte
  - évacuer (en option pour A2L)
  - purger avec du gaz inerte (en option pour A2L)
  - ouvrir le circuit par coupure ou brasage

## **! DANGER Continué**

- Si une fuite est suspectée, toutes les flammes nues doivent être enlevées/éteintes.
- Si une fuite de réfrigérant nécessitant un brasage est constatée, tout le réfrigérant doit être récupéré dans le système ou isolé (au moyen de vannes d'arrêt) dans une partie du système éloignée de la fuite.
- Lors de l'élimination du réfrigérant d'un système, que ce soit pour l'entretien ou la mise hors service, il est recommandé de veiller à ce que tous les réfrigérants soient éliminés en toute sécurité.
- Lors du transfert de réfrigérant dans des bouteilles, veillez à ce que seules des bouteilles de récupération de réfrigérant appropriées soient utilisées. Assurez-vous que le nombre de bouteilles nécessaires pour contenir la charge totale du système est disponible. Toutes les bouteilles à utiliser sont désignées pour le réfrigérant récupéré et étiquetées pour ce réfrigérant (c'est-à-dire des bouteilles spéciales pour la récupération du réfrigérant). Les bouteilles doivent être équipées d'une soupape de surpression et de soupapes d'arrêt associées qui sont en bon état de fonctionnement. Les bouteilles de récupération vides sont évacuées et, si possible, refroidies avant la récupération.
- L'équipement de récupération doit être en bon état de fonctionnement, accompagné d'un ensemble d'instructions concernant l'équipement disponible et doit être adapté à la récupération de tous les réfrigérants appropriés, y compris, le cas échéant, les réfrigérants inflammables. En outre, un ensemble de balances étalonnées doit être disponible et en bon état de fonctionnement. Les tuyaux doivent être complets, équipés de raccords de déconnexion sans fuite et en bon état. Avant d'utiliser la machine de récupération, vérifiez qu'elle est en bon état de fonctionnement, qu'elle a été correctement entretenue et que tous les composants électriques associés sont scellés pour éviter toute inflammation en cas de fuite de réfrigérant. Consulter le fabricant en cas de doute.
- Le réfrigérant récupéré doit être renvoyé au fournisseur de réfrigérant dans la bouteille de récupération appropriée et le bon de transfert de déchets correspondant doit être établi. Ne mélangez pas les réfrigérants dans les unités de récupération et surtout pas dans les bouteilles.
- Si les compresseurs ou les huiles de compresseur doivent être retirés, assurez-vous qu'ils ont été évacués à un niveau acceptable afin de s'assurer qu'il ne reste pas de réfrigérant inflammable dans le lubrifiant. Le processus d'évacuation doit être effectué avant que le compresseur ne soit renvoyé aux fournisseurs. Seul le chauffage électrique du boîtier du compresseur doit être utilisé pour accélérer ce processus. Lorsque l'huile est vidangée d'un système, cette opération doit être effectuée en toute sécurité.

## **! DANGER Continué**

- En plus des procédures de charge conventionnelles, les exigences suivantes doivent être respectées :
  - S'assurer qu'aucune contamination de différents réfrigérants ne se produit lors de l'utilisation de l'équipement de charge. Les tuyaux ou conduites doivent être aussi courts que possible afin de minimiser la quantité de réfrigérant qu'ils contiennent.
  - Les bouteilles doivent être maintenues dans une position appropriée conformément aux instructions.
  - S'assurer que le système de réfrigération soit mis à la terre avant de charger le système avec du réfrigérant.
  - Étiqueter le système lorsque la charge est terminée (si cela n'a pas déjà été fait).
  - Il faut veiller à ne pas trop remplir le système de réfrigération.
- Avant de recharger le système, celui-ci doit être testé sous pression avec le gaz de purge approprié. Le système doit être soumis à un essai de fuite à la fin de la charge, mais avant la mise en service. Un test de contrôle de fuite doit être effectué avant de quitter le site.
- La réparation et l'entretien des composants électriques incluent les contrôles de sécurité initiaux et les procédures d'inspection des composants. En cas de défaut susceptible de compromettre la sécurité, aucune alimentation électrique ne doit être connectée au circuit tant que le problème n'a pas été résolu de manière satisfaisante. Si le défaut ne peut être corrigé immédiatement mais qu'il est nécessaire de poursuivre l'exploitation, une solution temporaire adéquate doit être utilisée. Cela doit être signalé au propriétaire de l'équipement, afin que toutes les parties soient informées.
- S'assurer que les condensateurs sont déchargés : cette opération doit être effectuée en toute sécurité afin d'éviter tout risque d'étincelle.
- S'assurer qu'aucun composant ou câblage électrique sous tension n'est exposé lors de la charge, de la récupération ou de la purge du système.
- S'assurer de la continuité de la mise à la terre.
- Lors des réparations de composants scellés, toutes les alimentations électriques doivent être déconnectées de l'équipement sur lequel on travaille avant tout retrait des couvercles scellés, etc. Si l'alimentation électrique de l'équipement est absolument nécessaire pendant l'entretien, un dispositif de détection des fuites fonctionnant en permanence doit être placé au point le plus critique afin de signaler en cas de situation potentiellement dangereuse.
- Lorsque des composants électriques sont remplacés, ils doivent être adaptés à l'usage prévu et répondre aux spécifications correctes. Les directives de maintenance et d'entretien de Hoshizaki America doivent être respectées à tout moment. En cas de doute, consulter le service d'assistance technique de Hoshizaki America pour obtenir de l'aide.
- S'assurer que la charge réelle de réfrigérant est conforme à la taille de la pièce dans laquelle les pièces contenant du réfrigérant sont installées.
- S'assurer que les dispositifs et les sorties de ventilation fonctionnent correctement et ne sont pas obstrués.

## **! DANGER Continué**

- S'assurer que le marquage de l'équipement est toujours visible et lisible. Les indications et les panneaux illisibles doivent être corrigés.
- S'assurer que les tuyaux ou les composants de réfrigération sont installés dans un endroit où ils ne risquent pas d'être exposés à une substance susceptible de corroder les composants contenant du réfrigérant, à moins que les composants ne soient construits avec des matériaux intrinsèquement résistants à la corrosion ou qu'ils ne soient protégés de manière appropriée contre la corrosion.
- Une attention particulière doit être accordée aux points suivants afin de s'assurer qu'en travaillant sur les composants électriques, le boîtier n'est pas altéré de manière à ce que le niveau de protection soit affecté. Il s'agit notamment des dommages causés aux câbles, du nombre excessif de connexions, des terminaux non conformes aux spécifications d'origine, des dommages causés aux joints et du montage incorrect des presse-étoupes, etc.
- S'assurer que l'appareil (boîtier de commande/composant) est solidement fixé.
- S'assurer que les joints ou les matériaux d'étanchéité ne sont pas dégradés au point de ne plus pouvoir empêcher la pénétration d'atmosphères inflammables. Les pièces de rechange doivent être conformes aux spécifications de Hoshizaki America.
- N'appliquez aucune charge inductive ou capacitive permanente au circuit sans vous assurer que celle-ci ne dépassera pas la tension et le courant autorisés pour l'équipement utilisé.
- Les composants à sécurité intrinsèque sont les seuls types de composants sur lesquels il est possible de travailler sous tension en présence d'une atmosphère inflammable. L'appareil d'essai doit être adapté à la puissance requise.
- Ne remplacer les composants que par des pièces spécifiées par Hoshizaki America. D'autres pièces peuvent entraîner l'inflammation du réfrigérant dans l'atmosphère à la suite d'une fuite.
- Vérifier que le câblage ne sera pas soumis à l'usure, à la corrosion, à une pression excessive, à des vibrations, à des arêtes vives ou à tout autre effet environnemental négatif. Le contrôle doit également prendre en compte les effets du vieillissement ou des vibrations continues provenant de sources telles que les compresseurs ou les ventilateurs.

## B. Service Diagnosis

	<b>R-290 Class A3 Flammable Refrigerant Used</b>
<b>! DANGER</b>	
<b><u>Risk of Fire or Explosion. Flammable Refrigerant Used.</u></b> <ul style="list-style-type: none"><li>• Be sure to follow all Important Safety Information located at the beginning of this manual and at the beginning of section "III.A. Safety Precautions When Servicing."</li><li>• Servicing shall be done by trained service personnel with certified competence in handling flammable refrigerants to minimize the risk of possible ignition due to incorrect parts or improper service.</li></ul>	
<b><u>Risque De Feu Ou D'Explosion. Fluide Frigorigène Inflammable Utilisé.</u></b> <ul style="list-style-type: none"><li>• Assurez-vous de suivre toutes les informations importantes de sécurité qui se trouvent au début du présent manuel et au début de la section «III.A. Précautions de sécurité lors de l'entretien.»</li><li>• L'entretien doit être effectué par du personnel formé et certifié pour la manipulation de réfrigérants inflammables afin de réduire au minimum le risque d'inflammation dû à des pièces incorrectes ou à un entretien inadéquat.</li></ul>	
<b>⚠ WARNING</b>	
<ul style="list-style-type: none"><li>• Risk of electric shock. Use extreme caution and exercise safe electrical practices.</li><li>• Risk of electric shock. Control switch in "OFF" position does not de-energize all loads (optional drain pump).</li><li>• Move the control switch to the "OFF" position, then unplug the appliance from the electrical outlet before servicing.</li><li>• Moving parts (e.g., fan blade) can crush and cut. Keep hands clear.</li><li>• <b>CHOKING HAZARD:</b> Ensure all components, fasteners, and thumbscrews are securely in place after the appliance is serviced. Make sure that none have fallen into the ice storage bin.</li><li>• Make sure all food zones in the appliance are clean after service.</li></ul>	

The diagnostic procedure is a sequence check that allows you to diagnose the electrical system and components. Before proceeding, check for correct installation, proper voltage per nameplate, and adequate water supply. Check that the 5A fuse is good. Check CB using the steps in "III.C. Control Board Check."

- Note:
- When checking high voltage (115VAC), always choose a white (W) neutral wire to establish a good neutral connection.
  - When checking voltage from the CB connectors, pull CB connectors out slightly to allow room for multimeter test leads contact.
  - If the icemaker has an error code, see "IV.F. Error Codes."
  - CB monitors the following with 5VDC during the icemaking process: evaporator thermistor (ET) and bin control (BC). When 5VDC is present across either of these, the switch is open.

- 1) Remove the front panel. Move the control switch to the "OFF" position, then unplug the appliance from the electrical outlet.
- 2) Clear any ice from BC.

## 1. Operation Diagnosis

- 1) **Startup Cycle:** Turn on the power supply. Move the control switch to the "ICE" position. "on" appears on CB display. HGV energizes and Comp/AMD 30-sec. delay timer.

Note: • CB "on" display remains on unless the 10.5VAC power supply to CB CN1 is interrupted.

- Check CB using the steps in "III.C. Control Board Check."
- Confirm BC is CLOSED. If BC is open, remove ice from BC. If no ice is around BC and icemaker does not start, see "III.D. Bin Control Check."

- a) **Startup Cycle Diagnosis:** If CB "on" is off, confirm 5A fuse is good. Check for 115VAC at CS #2 (DBU) to neutral (W) then at CS #1 (R) to neutral (W). If 115VAC is present on #2 (DBU) and not on #1 (R), replace CS. If 115VAC is present on CS #1 (R), check for 115VAC at HPS (R) to neutral (W) then HPS (DBU) to neutral (W). If 115VAC is present at HPS (R) and not at HPS (DBU), HPS is open. See "b) HPS Diagnosis" below. If 115VAC is present at HPS (DBU), check for 10.5VAC at CB CN1 #1 red wire to CB CN2 #1 red wire. If 10.5VAC is not present, check CT continuity. If open, replace CT. If 10.5VAC is present and CB "on" display is not on, replace CB.

- b) **HPS Diagnosis:** If HPS is open, HPS automatically resets when refrigeration circuit high-side pressure is within an acceptable range. If HPS does not reset (open), allow pressures to equalize and HPS to reset. If refrigeration circuit high-side pressure does not drop, recover, evacuate, and recharge if necessary. Before restarting the appliance, check for dirty or clogged condenser. Once the appliance is restarted, check:

Harvest Cycle: HGV or strainer.

Freeze Cycle: FM, TXV, drier, and fan blade for binding.

If high-side refrigerant pressures have returned to an acceptable range and HPS does not close, replace HPS.

Confirm that the location meets installation requirements. See the appliance's instruction manual for details.

- 2) **Harvest Cycle:** Comp 30-sec. delay timer terminates, 20-sec. WV delay timer starts, Comp and AMD (opening) energize. HGV continues. 20-sec. WV delay timer terminates, WV energizes. WV 24 sec. on timer starts. AMD de-energizes when AMPS activates at water pan assembly fully open position. Once ET reaches 41°F (5°C), HGV de-energizes, FM and AMU (closing) energize. 24-sec. WV on timer terminates, WV de-energizes. AMU (closed) de-energizes when AMPS activates at water pan assembly fully closed position. Note: HGV de-energizes when ET reaches 41°F (5°C). During a start up scenario this occurs at the same time AMU (closing) and FM energize. Evap starts cooling before harvest cycle is complete. Harvest cycle is complete once AMPS indicates the water pan assembly is fully closed (up).

- a) **Comp Diagnosis:** Check that Comp energizes and evaporator is warming. If not, check for 115VAC at CB CN3 #9 orange (O) to neutral (W). If 115VAC is not present, check for 115VAC at CB CN2 #3 red (R) to neutral (W). If 115VAC is not present, at CN2 #3 (R), see "1)a) Startup Cycle Diagnosis" above. If 115VAC is present at CB CN2 #3 red (R) and not at CB CN3 #9 orange (O), replace CB. If 115VAC is present at CB CN3 #9 orange (O), check for 115VAC at CR solenoid. If 115VAC is present, confirm contacts are closed. If not, replace CR. If CR contacts are closed, check Comp external protector, Comp start capacitor, start relay, and motor winding.
- b) **HGV Diagnosis:** If Comp is energized and evaporator is not warming, check that HGV energizes and opens. Check for 115VAC at CB CN3 #3 (P) to neutral (W). If 115VAC is not present, replace CB. If 115VAC is present, check for 115VAC at HGV coil and check HGV coil continuity. Replace as needed.
- c) **AMD Diagnosis:** AMD energizes (opens). If not, check for 115VAC at CN5 #3 (GY) to neutral (W). If 115VAC is not present, replace CB. If 115VAC is present, check AM actuator arms for binding, spring connections, capacitor, and motor windings. If AMPS does not indicate water pan assembly is fully open within 3 min. display shows "EE" and icemaker shuts down for 60 min. If error recurs after icemaker resumes operation, display shows "EE" again and icemaker shuts down. See "IV.F. Error Codes."
- d) **WV Diagnosis:** 20-sec. WV delay timer terminates. WV energizes. Check that water enters the water tank. If not, check that the water supply line shut-off valve is open and screens or external filters are clear. Check for 115VAC at CB CN3 #7 (V) to neutral (W). If 115VAC is not present, replace CB. If 115VAC is present and WV does not energize, check for 115VAC at WV. If 115VAC is present, check coil continuity. If open, replace WV. If 24-sec. WV on timer terminates, and WV does not de-energize, check for 115VAC at CB CN3 #7 (V) to neutral for 115VAC. If 115VAC is present, (WV does not de-energize during harvest), replace CB. If 115VAC is not present, check for WV leaking by. Clean or replace WV.
- 3) **Freeze Cycle:** AMPS activated (water pan assembly completely closed). WV energizes. 74-sec. or 37-sec. timer starts. Comp and FM continue. Evaporator cooling. Once 74-sec. or 37-sec. timer terminates, WV de-energizes and PM energizes.
- a) **AMU Diagnosis:** AMU completes its rotation and AMPS is activated. If AM does not rotate up, check for 115VAC at CB CN5 #1 (O) to neutral (W). If 115VAC is not present, confirm ET is at 41°F (5°C) or higher. If ET achieved and AM does not energize, replace CB. If 115VAC is present, check AM actuator cams A and B for binding, actuator springs for proper connection, capacitor, and AM motor windings. Repair or replace as needed. If AMPS does not indicate water pan assembly is fully closed within 3 min. display shows "EE" and unit shuts down for 60 min. If error recurs after icemaker resumes operation, display shows "EE" again and icemaker shuts down. See "IV.F. Error Codes."

- b) **Freeze Cycle Diagnosis:** If Comp de-energizes once freeze begins, check that appliance has not shut off on HPS ("on" display off). If so, check "1)b) HPS Diagnosis" above. If "on" display is on, check for 115VAC at CB CN3 #9 (O) to neutral (W). If 115VAC is not present, replace CB. Confirm Comp and FM continue. Confirm that PM energizes after PM delay timer terminates and WV de-energizes once 74-sec. or 37-sec. WV on timer terminates. Confirm evaporator is cooling. If not, confirm HGV de-energized (not bypassing) and FM energizes, TXV operating correctly, Comp is efficient, and refrigerant charge is correct. See "VIII.A. Specification and Performance Data." Note: Refrigerant gauges should not be placed on the icemaker until all other components have been confirmed.
- c) **Comp Diagnosis:** If Comp is not energized, check for 115VAC at CB CN3 #9 (O). If 115VAC is present, check for 115VAC at CR coil. If 115VAC is present, check CR coil and contact continuity. Replace as needed. If CR is okay, check Comp start relay, start capacitor, and motor winding continuity. If Comp is energized but evaporator is not cooling, check for HGV leaking by or an inefficient Comp. See "VIII.A. Specification and Performance Data."
- d) **FM:** If Comp is energized but FM is not, check for 115VAC at CB CN3 #5 (BR) to neutral. If 115VAC is not present, replace CB. If 115VAC is present, check capacitor, motor winding, and fan blade for binding.
- e) **PM:** After 74-sec. or 37-sec. timer terminates, confirm water is flowing over evaporator. If not, check for 115VAC at CB CN3 #1 (BK) to neutral (W). If 115VAC is not present, replace CB. If 115VAC is present and PM is de-energized, check PM impeller for binding, capacitor, and motor winding continuity.
- f) **WV Diagnostics:** WV energizes, 74-sec. or 37-sec. timer starts. Check that water enters the water pan assembly. If not, check that the water supply line shut-off valve is open and screens or external filters are clear. Check for 115VAC at CB CN3 #7 (V) to neutral (W). If 115VAC is not present, replace CB. If 115VAC is present and WV does not energize, check for 115VAC at WV. If 115VAC is present, check coil continuity. If open, replace WV. 74-sec. or 37-sec. timer terminates. WV de-energizes. If WV continues, check for 115VAC at CB CN3 #7 (V) to neutral (W). If 115VAC is present, and 74-sec. or 37-sec. timer has terminated, replaced CB. If WV de-energizes and water continues to fill the reservoir, replace WV.

**Freeze Termination:** CB monitors time after ET temperature  $\leq 32^{\circ}\text{F}$  ( $0^{\circ}\text{C}$ ).

CB terminates freeze cycle when the following equation is satisfied:

temp. (absolute value)  $\times$  time (min.) = (absolute value of CB Setting 2)  $\times$  (CB Setting 3)

Using default settings, freeze cycle is terminated when:

temp. (absolute value)  $\times$  time (min.) = 382.5

This formula helps maintain consistent dimple size regardless of differences in seasonal ambient and water temperatures.

ET temperature is recorded 30 seconds after PM energizes. Water temperature correction value (CB Setting 13) is added to ET temperature and this is used as WT value in the following harvest cycle. If  $\text{CBT} > 32^{\circ}\text{F}$  ( $0^{\circ}\text{C}$ ) (CB Setting 74) and  $\text{CBT} \leq 111^{\circ}\text{F}$  ( $44^{\circ}\text{C}$ ) (CB Setting 70), when  $\text{ET} \leq -8.5^{\circ}\text{F}$  ( $-22.5^{\circ}\text{C}$ ) (CB Setting 2), HGV energizes 10 sec., de-energizes 20 sec., energizes 10 sec. (CB Settings 71) to reduce bonding of the water pan assembly to the evaporator.

4) **Harvest Cycle:** Same as the initial harvest cycle. Return to step 2) above.

Note: Appliance continues to cycle until BC is satisfied or power is switched off.

The appliance always restarts at the startup cycle.

## 2. Shutdown Diagnosis

- 1) When BC is engaged (open) for more than 10 sec., if in freeze cycle, the icemaker shuts down after harvest cycle (water pan assembly open). If in harvest cycle or if BC is engaged (open) while the water pan assembly is opening after the power supply is turned on (or after the "RESET" button is pressed), shutdown does not start: Shutdown occurs 10 sec. after AMPS indicates water pan assembly is fully open (down). When BC is disengaged (closed) for more than 80 sec., icemaker restarts at startup cycle. See "III.D.1. Bin Control Check."

Legend: **AMD**—actuator motor down; **AMPS**—actuator motor position sensor;

**AMU**—actuator motor up; **BC**—bin control; **CB**—control board; **CBT**—control board thermistor; **Comp**—compressor; **CS**—control switch; **CR**—compressor relay;

**ET**—evaporator thermistor; **FM**—fan motor; **HGV**—hot gas valve; **HPS**—high-pressure switch; **PM**—pump motor; **WT**—water temperature; **WV**—inlet water valve

## C. Control Board Check

Before replacing CB that does not show a visible defect and that you suspect is bad, always conduct the following check procedure. This procedure will help you verify your diagnosis. Always choose a white (W) neutral wire to establish a good neutral connection when checking voltages.

**Error Codes:** If CB is in error (E1, E2, EE(3-9), EE(EA), EE(EC), EE(Ed)), see "IV.F. Error Codes."

- 1) Move CS to the "ICE" position. If CB "on" display turns on, control voltage is good, continue to step 2.

**Diagnosis CB "on" Display:** If CB "on" display is off, check CT secondary circuit. CT output is 10.5VAC at 115VAC primary input. If the secondary circuit has proper voltage and CB "on" display is off, replace CB.

If the secondary circuit does not have proper voltage, check CT primary circuit. Check for 115VAC at 5A fuse (BR) to neutral (W). If 115VAC is not present, check power supply and breaker. If 115VAC is present, check for 115VAC at CS terminal #2 (DBU) to neutral (W). If 115VAC is not present, check 5A fuse continuity. If 115VAC is present, check for 115VAC at CS terminal #1 (R) to neutral (W). If 115VAC is not present, replace CT. If 115VAC is present, check for 115VAC at HPS (DBU) to neutral (W). If 115VAC is not present, see "III.B.1.1)b). HPS Diagnosis." If 115VAC is present, and secondary circuit does not have proper voltage, . replace CT.

- 2) To verify voltage output from CB to the components, slide CB connector out far enough to allow multimeter lead contact. With the icemaker in the cycle to be tested, check output voltage from the corresponding pin on CB connector to a neutral (W wire). If output voltage is not found, replace CB.
- 3) Confirm BC communication and shutdown sequence: Move CS to the "ICE" position. Once the startup cycle starts, press and hold the BC actuator paddle. CB shuts down the appliance after the next harvest cycle. If not, confirm BC status. See "III.D.1. Bin Control Check." If BC checks okay, replace CB.

Legend: **BC**—bin control; **CB**—control board; **CS**—control switch; **CT**—control transformer; **HPS**—high-pressure switch

## D. Bin Control Check

### 1. Bin Control Check

This appliance uses a lever-actuated proximity switch to control the ice level in the storage bin. No adjustment is required.

To check BC, follow the steps below.

- 1) Turn off the power supply.
- 2) Remove the front panel, then move the control switch to the "OFF" position.
- 3) Remove the control box cover. Clear any ice away from BC.
- 4) Check BC wire harness connections.
- 5) Disconnect BC wire harness connector from CB CN11 connector.
- 6) Check for continuity across the wires of BC wire harness connector. When the actuator paddle is not engaged, BC switch is closed. If open, check that the wire harness connector is properly connected and that the actuator paddle is not sticking. Clean if necessary. See "III.D.2. Bin Control Cleaning." If BC switch still reads open, replace BC.
- 7) Press and hold the actuator paddle; check for continuity across the wires of BC wire harness connector. When the actuator paddle is engaged, BC switch is open. If closed, check that the actuator paddle is not restricted. Clean if necessary. See "III.D.2. Bin Control Cleaning." If BC switch still reads closed, replace BC.
- 8) Reconnect BC wire harness connector to CB CN11 connector, then move the control switch to the "ICE" position. Turn on the power supply.
- 9) Allow the icemaker to cycle on. Press and hold the actuator paddle for at least 10 sec. The icemaker should shut down. If it does not, replace CB.  
Note: If BC is engaged (open) while the water pan assembly is opening after the power supply is turned on (or after the "RESET" button is pressed), shutdown does not start: Shutdown occurs 10 seconds after actuator motor's internal position sensor indicates water pan assembly is fully open.

Cycle at Mechanical Bin Control Activation	Shutdown
Harvest Cycle	At the end of the harvest cycle, or up to 15 sec. into the freeze cycle if activated at the end of the harvest cycle.
Freeze Cycle	15 sec. after activation if activated at least 15 sec. before the 5-min. short cycle protection timer terminates. Otherwise, at the end of the next harvest cycle.

Legend: **BC**—bin control; **CB**—control board

## 2. Bin Control Cleaning

Scale may build up on BC. Scale can cause the actuator paddle and magnet to stick. In this case, BC should be cleaned.

### **⚠ WARNING**

**CHOKING HAZARD:** Ensure all components, fasteners, and thumbscrews are securely in place after the icemaker is serviced. Make sure that none have fallen into the dispense unit/ice storage bin.

- 1) Turn off the power supply.
- 2) Remove the front panel, then move the control switch to the "OFF" position.
- 3) Clear any ice away from BC.
- 4) Carefully remove the BC cable from the cable ties in the evaporator case, then remove the BC from the bin control bracket and move to the front of the icemaker for cleaning.
- 5) Remove the actuator paddle from the switch mount. See Fig. 1.
- 6) Wipe down BC with a mixture of 1 part of Hoshizaki "Scale Away" and 25 parts of warm water. Rinse the parts thoroughly with clean water.
- 7) Reassemble BC and replace it in its correct position.  
Note: If the magnet was removed for cleaning, be sure to replace it in its correct position.
- 8) Replace the BC cable into the cable ties in the evaporator case, then move the control switch to the "ICE" position.
- 9) Confirm CB wire harness connections are secure, then replace the control box cover in its correct position.
- 10) Turn on the power supply to start the automatic icemaking process.
- 11) Replace the front panel in its correct position.

Legend: **BC**—bin control; **CB**—control board

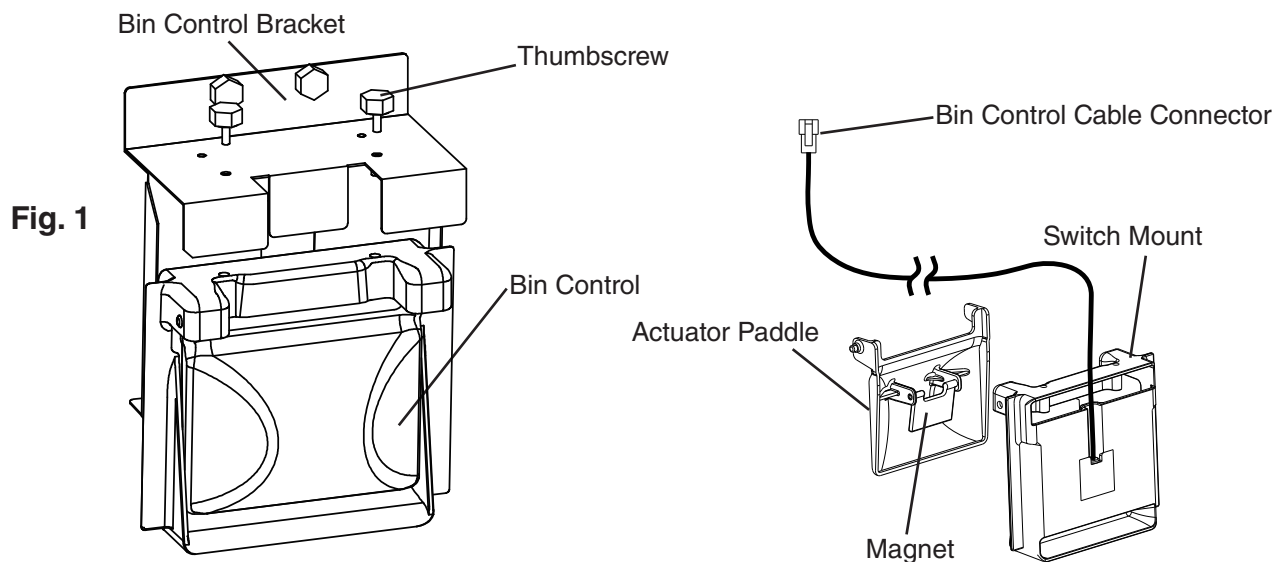

## E. Evaporator Thermistor Check

To check thermistor resistance, follow the steps below.

- 1) Turn off the power supply.
- 2) Remove the front panel. Move the control switch to the "OFF" position.
- 3) Remove the control box cover.
- 4) Remove the thermistor from the evaporator.
- 5) Immerse the thermistor sensor portion in a glass containing ice and water for 2 or 3 min.
- 6) Disconnect the thermistor connector from CB CN13 connector and check the resistance between thermistor leads. Normal range is 4.7 to 6.2 k $\Omega$ . If outside the normal range, replace the thermistor. See "IV.I. Component Service Information." If within the normal range, continue to the next step.
- 7) Replace the thermistor in its correct position. See "IV.I. Component Service Information."
- 8) Reconnect the thermistor connector to CB CN13 connector.
- 9) Replace the control box cover in its correct position.
- 10) Move the control switch to the "ICE" position.
- 11) Replace the front panel in its correct position.
- 12) Turn on the power supply.

Legend: **CB**—control board; **Comp**—compressor

## F. Control Switch

The control switch has three positions: "OFF" for power off, "ICE" for icemaking, and "WASH" to energize the pump motor when cleaning and sanitizing.

**WARNING! Control switch in "OFF" position does not de-energize all loads. Risk of electric shock. Use extreme caution and exercise safe electrical practices.**

## G. Diagnosis Table

First see "IV.F. Error Codes." If there are no recorded errors, refer to the table below.

No Ice Production - Possible Cause	
1. Power Supply	a) Off, blown fuse, or tripped breaker.
	b) Not within specifications.
2. Fuse (Control Box)	a) Blown.
3. Control Switch	a) In "OFF" or "WASH" position.
	b) Bad contacts.
4. High-Pressure Switch	a) Dirty condenser or air filter.
	b) Fan motor not operating.
	c) Refrigerant overcharged.
	d) Bad contacts.
	e) Refrigerant lines or components restricted.
5. Control Transformer (115VAC/10.5VAC)	a) Coil winding open or shorted.
6. Control Board See "III.C. Control Board Check"	a) Error. See "IV.F. Error Codes."
	b) Defective.
7. Bin Control See "III.D. Bin Control Check"	a) Tripped with bin filled with ice.
	b) Actuator does not move freely.
	c) Defective.
8. Water Supply	a) Water supply off or improper water pressure.
	b) External water filters restricted.
9. Inlet Water Valve	a) Screen or orifice restricted.
	b) Coil winding open.
10. Compressor	a) Compressor relay/magnetic contactor contacts bad or coil winding open.
	b) Start capacitor or run capacitor defective (single phase).
	c) Internal protector open.
	d) Start relay contacts bad or coil winding open (single phase).
	e) Defective.
11. Hot Gas Valve	a) Defective.
12. Evaporator (Cube Control) Thermistor See "III.E. Evaporator Thermistor Check"	a) Loose, disconnected, or defective.
13. Pump Motor	a) Mechanical seal worn out.
	b) Defective.
	c) Defective capacitor.
14. Thermostatic Expansion Valve	a) Bulb loose.
	b) Defective.
15. Fan Motor	a) Defective.
	b) Defective capacitor.
16. Water System	a) Water leaks.

<b>Low Ice Production - Possible Cause</b>	
<b>Long Harvest Cycle</b>	
1. Evaporator	a) Scaled up.
2. Control Board	a) Thermistor connection loose (K3).
	b) Defective.
3. Evaporator (Cube Control) Thermistor See "III.E. Evaporator Thermistor Check"	a) Loose, disconnected, or defective.
4. Hot Gas Valve	a) Erratic or closed.
5. Compressor	a) Inefficient or off.
6. Thermostatic Expansion Valve	a) Defective.
7. Refrigerant Charge	a) Low.
<b>Long Freeze Cycle</b>	
1. Evaporator	a) Scaled up, dirty.
2. Hot Gas Valve	a) Defective.
3. Condenser	a) Restricted.
4. Control Board	a) Defective.
5. Thermostatic Expansion Valve	a) Bulb loose.
	b) Defective.
6. Compressor	a) Inefficient or off.
7. Refrigerant Charge	a) Low.
<b>Slab Does Not Break Into Separate Cubes - Possible Cause</b>	
1. Spring	a) Over-extended.
2. Water pan assembly	a) Obstacle caught between evaporator and water pan assembly.
<b>Cubes Drop Separately - Possible Cause</b>	
1. Refrigerant Charge	a) Low - Long harvest cycle.
2. Cam Arm	a) Worn out.
<b>Imperfect Ice Production - Possible Cause</b>	
1. Water Supply	a) Improper water pressure.
	b) External water filters restricted.
	c) Water leaks from water tank or water pan due to broken tank or plate or icemaker out of level.
2. Inlet Water Valve	a) Water leaks from valve body or water supply pipe joint.
3. Water Pan	a) Spray holes restricted.
4. Pump Motor	a) Defective.

<b>Large-Hole Cubes - Possible Cause (Also see IV.G.1. Dimple Diameter")</b>	
1. Condenser	a) Dirty condenser or air filter.
2. Fan Motor	a) Defective.
3. Refrigerant Charge	a) Low.
<b>Large-Hole Cubes - Possible Cause (Also see IV.G.1. Dimple Diameter")</b>	
4. Icemaker Location	a) Insufficient clearance.
	b) Ambient temperature too high.
5. Water Supply	a) Water leaks.
	b) Improper water pressure.
<b>Cloudy Cubes - Possible Cause</b>	
1. Water Quality	a) High hardness. See "IV.G.2. Ice Clarity."
2. Slush Ice	a) Use Anti-Slush Control (Control Board Settings 50 and 51).

# H. Freeze-Up Check List

## Freeze-Up Check List IM Series

Please Complete When Diagnosing a Freeze-Up, Refrigerant Leak, or Low Charge

Technical Support Fax #: 770-487-3360

Make Copies And Use As Needed

**Model #** \_\_\_\_\_ **Serial #** \_\_\_\_\_ **Install Date** \_\_\_\_\_ **Freeze-Up Date** \_\_\_\_\_

List model and manufacture of bin or dispenser \_\_\_\_\_.

Date appliance was last cleaned: \_\_\_\_\_.

### Freeze-Up Defrost

YES NO

- 1) After defrosting, was the appliance leak checked?
- 2) Were any leaks found?  
If so where? \_\_\_\_\_.
- 3) Was any refrigerant added to the unit?  
If so, how much? \_\_\_\_\_.

### Setup

- 4) Is the appliance stand alone?
- 5) Is water line independent?
- 6) Is water line correct size? If not \_\_\_\_\_?"  
1/4" Nominal ID Copper Water Tubing or Equivalent.
- 7) What is water pressure? \_\_\_\_\_.  
Water Temperature \_\_\_\_\_.
- 8) Does appliance have any water filtration?  
If yes please list the following:  
Filter brand \_\_\_\_\_.  
Model \_\_\_\_\_.  
Filter pressure gauge reading during the fill cycle \_\_\_\_\_.  
Date filter was last replaced? \_\_\_\_\_.  
GPM or LPM flow rate of filter system? \_\_\_\_\_.
- 9) Ambient temperature at appliance? \_\_\_\_\_.  
At remote condenser (if applicable)? \_\_\_\_\_.

### Appliance Status

- 10) Is the appliance dirty?
- 11) Are the actuator springs in place?
- 12) Are actuator cam A and Cam B in their correct positions?
- 13) Is the bin control properly mounted and secured?
- 14) Is the evaporator thermistor properly mounted, tight, and insulated?
- 15) Is the TXV bulb properly mounted, tight, and insulated (wrapped)?
- 16) Is there an error code on the control board display? if so, what error code? \_\_\_\_\_.

### Appliance Operation

YES NO

- 17) Does the water tank fill and overflow?
- 18) If NO in step 17, is water flow 5GPM or more?

### Startup

- 19) Is the hot gas valve opening?
- 20) Does the water valve remain energized for the appropriate time?
- 21) Does the water valve energize at correct times?
- 22) Does water valve close completely when de-energized?
- 23) What was length of harvest? \_\_\_\_\_.

### Freeze

- 24) Is pump motor energized in freeze cycle except during pump motor delay?
- 25) Are the water plate spray holes clean and providing proper water flow?
- 26) What was length of freeze? \_\_\_\_\_.
- 27) Is the cube size consistent across evaporator?
- 28) Is dimple size consistent throughout ice drop?
- 29) What is the ice drop weight? \_\_\_\_\_.
- 30) What is head pressure?  
Freeze \_\_\_\_\_ Harvest \_\_\_\_\_.  
(Freeze pressure should be taken 5 minutes into the cycle).
- 31) What is suction pressure?  
Freeze \_\_\_\_\_ Harvest \_\_\_\_\_.  
(Freeze pressure should be taken 5 minutes into the cycle).
- 32) Did appliance shut down when the bin control was activated?

Note: Make copies of this form and use it when diagnosing a freeze up condition. Submit a completed copy of the checklist along with the freeze-up labor claim form.

---

## IV. Controls and Adjustments

### A. Control Board

- A Hoshizaki exclusive control board is employed in IM series appliances.
- All models are pretested and factory adjusted.

<b><i>NOTICE</i></b>
<ul style="list-style-type: none"><li>• Fragile, handle very carefully.</li><li>• The control board contains integrated circuits, which are susceptible to failure due to static discharge. It is especially important to touch the metal part of the icemaker when handling or replacing the control board.</li><li>• Do not touch the electronic devices on the control board or the back of the control board.</li><li>• Do not change wiring and connections.</li><li>• Do not short out power supply to test for voltage.</li><li>• Always replace the whole control board assembly if it goes bad.</li></ul>

# 1. Control Board Layout

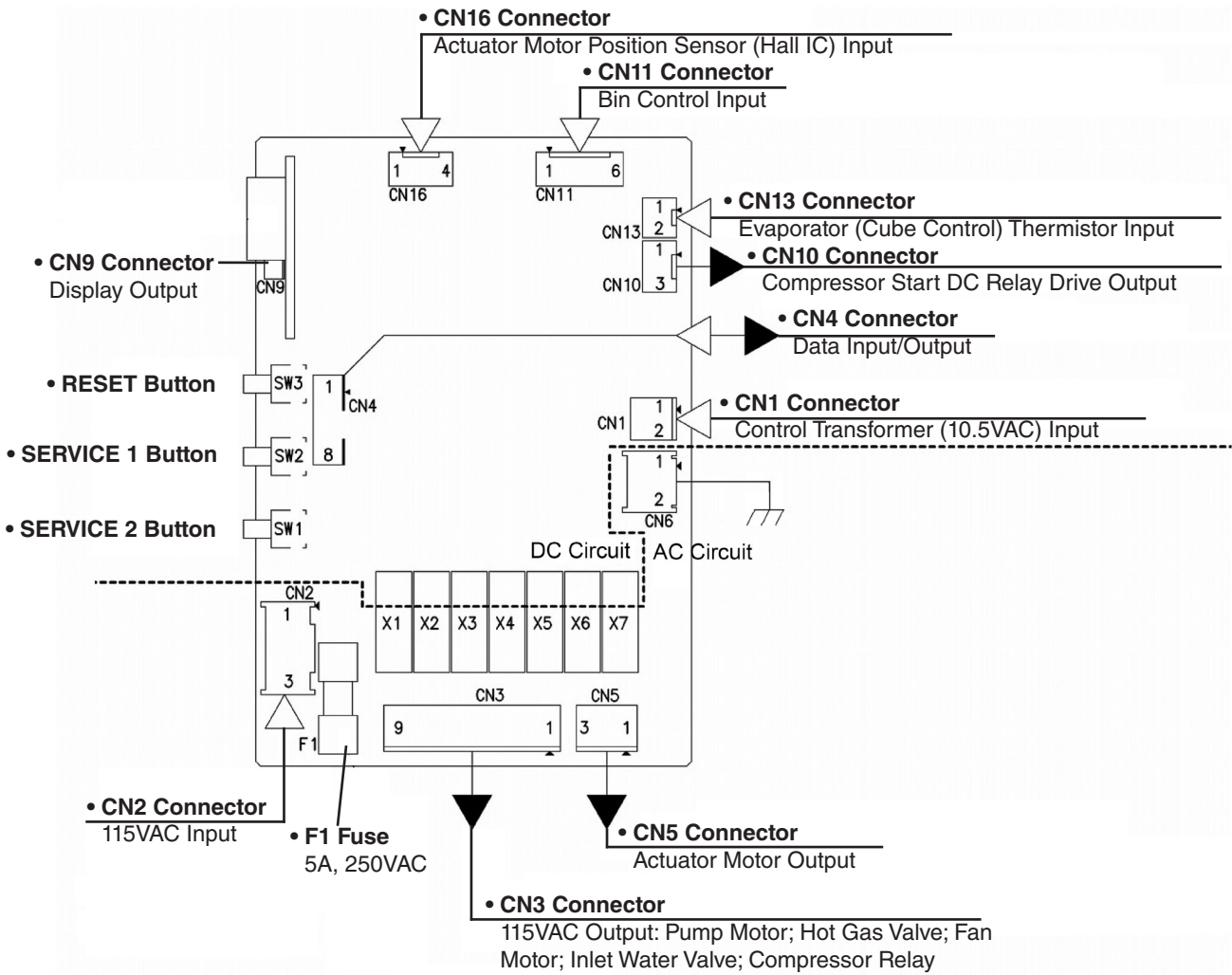

Control Board	
Part Number	P01873-02 Version 1.0C or Later

## B. Control Board Buttons

The control board features RESET, SERVICE 1, and SERVICE 2 Buttons

### 1. RESET Button

- Press briefly to go to initial harvest cycle.
- Press and hold for 3 seconds to enter control board setting mode. For details about control board settings, see "IV.E. Control Board Model Code Setting."

### 2. SERVICE 1 and SERVICE 2 Buttons

- Press the "SERVICE 1" or "SERVICE 2" button briefly to display the current freeze cycle termination temperature (Control Board Setting 2). This setting controls dimple diameter. For details about adjusting the dimple diameter, see "IV.G.1. Dimple Diameter." **NOTICE! Do not decrease dimple size below 3/16" (5 mm).**
- Press and hold the "SERVICE 1" button for 3 seconds to enter information display and model code setting mode. For details about information display and model code setting, see "IV.E. Control Board Model Code Setting."

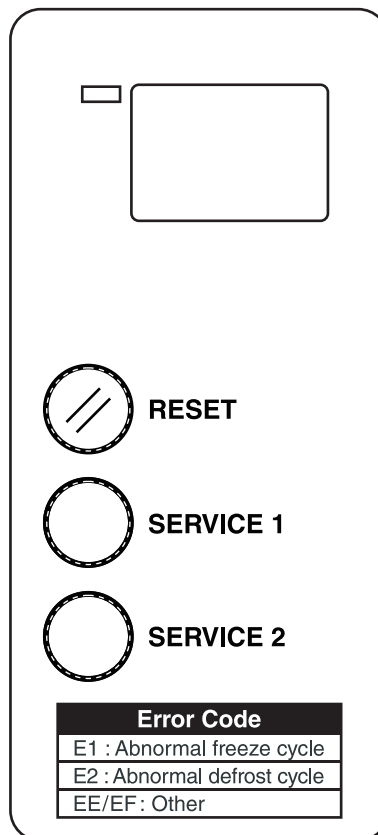

Fig. 2

## C. Control Board Settings

### **NOTICE**

Failure to maintain factory settings may adversely affect performance and warranty coverage. For more information, contact your Hoshizaki Service Center.

- 1) With "on" in display, press and hold the "RESET" button for 3 seconds. Display changes to "1".
- 2) Use the "SERVICE 1" and "SERVICE 2" buttons to choose a control board setting.
- 3) Press the "RESET" button to view the setting's value. Current value flashes in display.
- 4) Use the "SERVICE 1" and "SERVICE 2" buttons to change value.
- 5) Press the "RESET" button to select value. Display returns to control board setting number.
- 6) Once display returns to "on" (20 seconds), the new setting is saved.

<b>Control Board (CB) Setting Menu</b>				
<b>Category</b>	<b>No.</b>	<b>Item</b>	<b>Range</b>	<b>IM-200BAK Default</b>
Basic	1	<u>Harvest Cycle Termination Temperature</u> Temperature to complete harvest cycle.	2 to 20°C (1°C increments)	5
	2	<u>Freeze Cycle Termination Temperature</u> Integrated with freeze cycle termination time (CB Setting 3) to control length of freeze cycle after evaporator (cube control) thermistor temperature drops to 32°F (0°C). To use this setting for dimple size adjustment, see "IV.G.1. Dimple Diameter."	-19.5 to -25.5°C (0.5°C increments. The "." in the lower, right corner of the display indicates .5°C.)	-22.5
	3	<u>Freeze Cycle Termination Time</u> Integrated with freeze cycle termination temperature (CB Setting 2) to control length of freeze cycle after evaporator (cube control) thermistor temperature drops to 32°F (0°C).	15 to 19 min. (1 min. increments)	17
	4	<u>Ambient Temperature Correction Value for Freeze Cycle Termination</u> <b>DO NOT ADJUST</b>	10 to 50°C (1°C increments)	39
	5	<u>Ambient Temperature Correction Rate for Freeze Cycle Termination</u> <b>DO NOT ADJUST</b>	10 to 100% (00 = 100) (1% increments)	90
	6	<u>Freeze Cycle Backup Timer</u> Maximum allowed freeze time to prevent possible freeze-up issues.	45 to 90 min. (5 min. increments)	50
Water Supply	10	<u>Harvest Cycle Water Supply Time: Water Temperature 48°F (9°C) or Lower</u> When set to "99", inlet water valve energized until harvest cycle termination temperature (CB Setting 1) is reached.	1 to 99 sec, 99 = continuous (1 sec. increments)	98
	11	<u>Harvest Cycle Water Supply Time: Water Temperature Higher Than 48°F (9°C)</u> When set to "99", inlet water valve energized until harvest cycle termination temperature (CB Setting 1) is reached.	1 to 99 sec, 99 = continuous (1 sec. increments)	24

<b>Control Board (CB) Setting Menu</b>				
<b>Category</b>	<b>No.</b>	<b>Item</b>	<b>Range</b>	<b>IM-200BAK Default</b>
Water Supply, continued	12	<u>Freeze Cycle Water Supply Time 1: Partial Drain (CB Setting 14)</u>	0 to 90 sec. (1 sec. increments)	37
		<u>Freeze Cycle Water Supply Time 1: Full Drain (CB Setting 14)</u>		74
	13	<u>Water Temperature Correction Value</u> Value added to correct the difference between the temperature at the evaporator (cube control) thermistor and actual water supply temperature.	+0 to +20°C (1°C increments)	10
	14	<u>Partial/Full Drain Selection</u> Controls timing for inlet water valve and pump motor in the freeze cycle. <u>Partial Drain:</u> Pump motor energizes after freeze cycle water supply time 1 (CB Setting 12) timer terminates. During the first freeze cycle after startup or following a bin control initiated shutdown and restart, freeze cycle water supply times 1 and 2 (CB Settings 12 and 15) are doubled. <u>Full Drain:</u> Pump motor energizes after freeze cycle water supply time 1 (CB Setting 12) timer terminates. If full drain is selected, change freeze cycle making water supply times 1 and 2 (CB Settings 12 and 15) to the full drain times listed in this table and move the water tank drain pipe to the drain position. For details, see "IV.G.2. Ice Clarity."	Partial=1; Full=0	1
	15	<u>Freeze Cycle Water Supply Time 2: Partial Drain (CB Setting 14)</u>	0 to 90 sec. (1 sec. increments)	0
		<u>Freeze Cycle Water Supply Time 2: Full Drain (CB Setting 14)</u>		0
	17	<u>Ice Bridge Control Divided Harvest Cycle Water Supply</u> Divides harvest cycle water supply to prevent water from flowing over ice when ice drops in harvest.  e.g. CB Setting 1= 6 CB Setting 10 = 90 CB Setting 17 = 1 CB Setting 18 = 2 When set as above, harvest cycle water supply is as follows: Inlet water valve energizes for 40 sec. when harvest cycle starts. Inlet water valve energizes again when thermistor temperature reaches 39°F (4°C) (CB Setting 1 - CB Setting 18). Inlet water valve de-energizes after 50 sec. (CB Setting 10 - 40 sec.) or when thermistor temperature reaches 43°F (6°C) (CB Setting 1) whichever comes first.	Yes=1; No=0	0
	18	<u>Ice Bridge Control Divided Harvest Cycle Water Supply Restart Temperature Factor</u> When CB Setting 17 is set to 1, CB Setting 1 - CB Setting 18 = temperature at which harvest cycle water supply restarts.	0 to 20°C (1°C increments)	0

<b>Control Board (CB) Setting Menu</b>				
<b>Category</b>	<b>No.</b>	<b>Item</b>	<b>Range</b>	<b>IM-200BAK Default</b>
Other	21	<u>Stackable Bin Control</u> Allows for stacked units to be controlled through one bin control. <b>DO NOT ADJUST</b>	Yes=1; No=0	1
	22	<u>Refrigeration Circuit Cycling when Bin Full</u> <b>DO NOT ADJUST</b>	On=1; Off=0	0
Model	30	<u>Type</u> 0: WC, PS, No CondTherm, Ignore CB Setting 34 1: AC, No PS, No CondTherm, Use CB Setting 34 2: AC, No PS, CondTherm, Use CB Setting 34 3: AC, PS, No CondTherm, Use CB Setting 34 <b>DO NOT ADJUST</b>	0 to 3	3
Harvest Cycle High Temperature Control	34	<u>Harvest Cycle High Temperature Control</u> Active if type setting (CB Setting 30) is set to 1, 2, or 3. If control board thermistor temperature at the beginning of harvest cycle is equal to or greater than the harvest cycle high temperature control setting, fan motor operates continuously in harvest cycle.	40 to 70°C (1°C increments)	48
Water Regulating Valve	36	<u>Water Regulating Valve Error Detection Temperature</u> <b>DO NOT ADJUST</b>	0 to 50°C 0=ignore, air-cooled model (1°C increments)	0
Compressor	37	<u>Compressor Output Selection</u> <b>DO NOT ADJUST</b>	0: X8 (DC Relay) On 1: X1 (AC Relay) On	1
Anti-Slush Control	50	<u>Pump De-Energized Time</u> When temperature at evaporator (cube control) thermistor drops to 37°F (3°C) in the freeze cycle, pump de-energizes for the length of time set.	0 to 90 sec. 0=ignore, no anti-slush (1 sec. increments)	0
	51	<u>Anti-Slush Control Water Supply Time</u> Time inlet water valve is energized while pump is de-energized if pump de-energized time (CB Setting 50) is greater than 0.	0 to 5 sec. (1 sec. increments)	0
Hard Water Control	60	<u>Integrated Value</u> If hard water control water supply time (CB Setting 61) is greater than 0: After evaporator (cube control) thermistor indicates temperature of 32°F (0°C) in freeze cycle, inlet water valve energized starting when percentage of freeze cycle termination temperature and freeze cycle time integrated value has been achieved. <b>DO NOT ADJUST</b>	10 to 100% (00=100) (1% increments)	10
	61	<u>Hard Water Control Water Supply Time</u> Time inlet water valve is energized after integrated value (CB Setting 60) conditions are met. Before using this setting, follow the instructions to improve ice clarity; see "IV.G.2. Ice Clarity."	0 to 90 sec. (1 sec. increments)	0

<b>Control Board (CB) Setting Menu</b>				
<b>Category</b>	<b>No.</b>	<b>Item</b>	<b>Range</b>	<b>IM-200BAK Default</b>
Water Tank Ice Control	70 71 74	If control board thermistor temperature is above the water tank ice control lower temperature setting (CB Setting 74) and equal to or less than the water tank ice control upper temperature setting (CB Setting 70) when freeze cycle termination temperature (CB Setting 2) is met, the hot gas valve energizes/de-energizes/energizes for the times set by the hot gas valve energized/de-energized times (CB Settings 71) to reduce bonding of the water tank to the evaporator.	See Ranges Below	See Defaults Below
Water Tank Ice Control & Ice Bridge Control	70	<u>Water Tank Ice Control Upper Temperature</u> See CB Setting 70, 71, 74 description above. <u>Ice Bridge Control Temperature</u> See CB Setting 73 description below.	10 to 60°C (1°C increments)	39
Water Tank Ice Control	71	<u>Water Tank Ice Control Hot Gas Valve Energized Time</u> See CB Setting 70, 71, 74 description above.	0 to 10 sec. (1 sec. increments)	10
Ice Bridge Control	73	<u>Ice Bridge Control Hot Gas Valve De-Energized Time</u> Time hot gas valve is de-energized after 20 sec. in harvest cycle if control board thermistor temperature is above the ice bridge control temperature (CB Setting 70) when freeze cycle termination temperature (CB Setting 2) is met.	0 to 30 sec. (1 sec. increments)	0
Water Tank Ice Control & Harvest Cycle Low Temperature Control	74	<u>Water Tank Ice Control Lower Temperature</u> See CB Setting 70, 71, 74 description above. <u>Harvest Cycle Low Temperature Control</u> If control board thermistor temperature at the beginning of harvest cycle is equal to or less than the harvest cycle low temperature control setting, hot gas valve repeatedly energizes for 40 seconds then de-energizes for 40 seconds to promote a balanced harvest across the evaporator plate.	0 to 40°C (1°C increments)	0

## D. Control Board Information Display

- 1) With unit on, press and hold the "SERVICE 1" button for 3 seconds. Display changes to "n1".
- 2) Use the "SERVICE 1" and "SERVICE 2" buttons to move through the list.
- 3) Press the "RESET" button to view the item's value.
- 4) Press the "RESET" button to return to list.
- 5) Display returns to normal if no buttons are touched for 20 seconds.

Control Board Information Display			
No.	Item	Description	History Cleared by Pressing and Holding SERVICE 1 and SERVICE 2 Buttons Simultaneously for 5 Sec. when Item Value is Displayed?
n1	<u>Freeze Cycle Time</u> During Freeze Cycle: Time since freeze cycle started. After Freeze Cycle: Time of previous freeze cycle.	0 to 99 min.	No
n2	<u>Freeze Cycle Completion Rate</u> During Freeze Cycle: Percent of freeze cycle completed. After Freeze Cycle: Percent of previous freeze cycle completed.	0 to 100% 00 = 100%	No
n3	<u>Current Evaporator (Cube Control) Thermistor Temperature</u>	°C	No
n4	<u>Current Control Board Thermistor Temperature</u>	°C	No
n5	<u>Water Temperature</u> Temperature at evaporator (cube control) thermistor 30 seconds after pump motor energized in freeze cycle plus the water temperature correction value (Control Board Setting 13).	"H" if Higher than 48°F (9°C) "L" if 48°F (9°C) or Lower	No
n6	<u>Current Condenser Thermistor Temperature</u> Not Applicable to IM-200BAK	°C	No
h1	<u>Last Completed Freeze Cycle Time</u> Freeze cycles interrupted by bin control shutdown or the "RESET" button are not recorded.	0 to 99 min.	Yes
h2	<u>Number of Completed Freeze Cycles Since Last Counter Reset</u> Counter updates every 10 freeze cycles. Freeze cycles interrupted by bin control shutdown or the "RESET" button are not recorded.	Displays up to 999,999 cycles. Displays two digits at a time. For example, 655,350 cycles display as follows: 65>off>53>off>50>off>	Yes
h3	<u>Total Number of Completed Freeze Cycles</u> Counter updates every 10 freeze cycles. Freeze cycles interrupted by bin control shutdown or the "RESET" button are not recorded.	65>off>53>off>50>off> (repeat)	No

<b>Control Board Information Display</b>			
<b>No.</b>	<b>Item</b>	<b>Description</b>	<b>History Cleared by Pressing and Holding SERVICE 1 and SERVICE 2 Buttons Simultaneously for 5 Sec. when Item Value is Displayed?</b>
h4	<u>Error Log</u> Displays up to 5 errors with the most recent error first. For error details, see "IV.F. Error Codes."	For example, E5 (most recent), E4, E3, E2, E1 (least recent of up to 5 errors) displays as follows: E5>off>E4>off>E3>off>E2>off>E1>off>(repeat)	Yes
h5	<u>Firmware Version</u> Displays control board's firmware version.	For example, version 1.0A, displays as follows: 01.>off>0A>off>(repeat)	No
h6	<u>Model Code</u> The model code puts all settings for a given model to the correct default settings. The model code setting mode should only be used when the control board has been changed, the model code is incorrect, or to reset all settings to the default. For details about the model code setting mode, see "IV.E. Control Board Model Code Setting."	Displays two-character model code. "00" to "FF"	No

## E. Control Board Model Code Setting

### 1. Control Board Replacement

#### WARNING

- This appliance should be diagnosed and repaired only by qualified service personnel to reduce the risk of death, electric shock, serious injury, or fire.
- Move the control switch to the "OFF" position and unplug the appliance from the electrical outlet before servicing.

- 1) Remove the front panel and move the control switch to the "OFF" position. Unplug the appliance.
- 2) Remove the control box cover.
- 3) Disconnect all the connectors from the control board.
- 4) Remove the old control board and install the new control board ([P01873-02](#), Version 1.0C or Later).
- 5) Connect the connectors to the new control board.
- 6) Replace the control box cover in its correct position.
- 7) Plug in the appliance and then move the control switch to the "ICE" position.
- 8) "00" appears in the display of the new control board.
- 9) Press the "SERVICE 1" button to increase the first digit in the display and the "SERVICE 2" button to increase the second digit. Digits appear in the following order: 0, 1, 2, 3, 4, 5, 6, 7, 8, 9, A, B, C, D, E, F. When a valid model code is displayed, the dot in the bottom right of the display turns on. For IM-200BAK, set model code to "0A".
- 10) When the desired model code is displayed, press the "RESET" button to save the setting. "on" appears in the display.
- 11) Replace the front panel in its correct position.

### 2. Checking or Changing the Control Board Model Code

- 1) With unit on, press and hold the "SERVICE 1" button for 3 seconds. Display changes to "n1".
- 2) Use the "SERVICE 1" and "SERVICE 2" buttons to move through the list until "h6" is displayed.
- 3) Press the "RESET" button to view the current model code. To change the model code, continue through the remaining steps; otherwise, the display returns to normal if no buttons are touched for 20 sec.
- 4) Press and hold the "SERVICE 1" and "SERVICE 2" buttons simultaneously for 15 sec. "00" appears in display.
- 5) Press the "SERVICE 1" button to increase the first digit in the display and the "SERVICE 2" button to increase the second digit. Digits appear in the following order: 0, 1, 2, 3, 4, 5, 6, 7, 8, 9, A, B, C, D, E, F. When a valid model code is displayed, the dot in the bottom right of the display turns on. For IM-200BAK, set model code to "0A".
- 6) When the desired model code is displayed, press the "RESET" button to save the setting. "on" appears in the display.

## **F. Error Codes**

When the control board detects an error, the display shows one of the following error codes in the display mode. Error codes other than E1 and E2 are displayed as "EE" at the time of occurrence. To see the actual error code, see the error log.

1. With the unit on, press and hold the "SERVICE 1" button for 3 seconds. Display changes to "n1".
2. Use the "SERVICE 1" and "SERVICE 2" buttons to move through the list until "h4" is displayed.
3. Press the "RESET" button to view the error log. Displays up to 5 errors with the most recent error first.
4. Press the "RESET" button to return to list. To clear error log history, press and hold the "SERVICE 1" and "SERVICE 2" buttons simultaneously for 5 sec.
5. Display returns to normal if no buttons are touched for 20 sec.

<b>Error Codes</b>		
<b>Error Code</b>	<b>Problem</b>	<b>Corrective Action/Reset Details</b>
E1	<u>Freeze Cycle Backup Timer</u> Freeze cycle backup timer (Control Board Setting 6) has terminated. 50 min. after water tank starts to close in preceding harvest cycle, unit stops if the evaporator temperature is above 32°F (0°C).	Check for inlet water valve leaking by, hot gas valve leaking by, pump motor not pumping, thermostatic expansion valve not feeding properly, low charge, or inefficient compressor.  Press the "RESET" button to reset.
E2	<u>Harvest Cycle Backup Timer</u> Harvest cycle backup timer has terminated. 30 min. after water tank starts to open in harvest cycle, unit stops if harvest cycle termination temperature (Control Board Setting 1) has not been reached.	Check for open thermistor, HGV not opening, TXV leaking by, low charge, or inefficient compressor.  Press the "RESET" button to reset.
EE (E3)	<u>Water Tank Opening Backup Timer</u> 3-minute opening backup timer starts when water tank starts to open. If actuator motor's internal position sensor does not indicate water tank is fully open within 3 minutes, display shows "EE" and unit stops for 60 minutes. If error recurs after unit resumes operation, display shows "EE" and unit shuts down.	Check actuator motor and control board.  Press the "RESET" button to reset.
EE (E4)	<u>Water Tank Closing Backup Timer</u> 50-second closing backup timer starts when water tank starts to close. If actuator motor's internal position sensor does not indicate water tank is fully closed within 50 seconds, display shows "EE" and unit stops for 60 minutes. If error recurs after unit resumes operation, display shows "EE" and unit shuts down.	Check actuator motor and control board.  Press the "RESET" button to reset.
EE (E5)	<u>High Evaporator Temperature</u> If evaporator temperature 140°F (60°C) or higher for 5 sec., unit stops.	Check for harvest problem (stuck HGV or control board relay), hot water entering unit, or shorted thermistor.  Press the "RESET" button to reset.
EE (E9)	<u>Condenser Thermistor Error</u> If condenser thermistor is open or shorted for 2 sec., unit stops. Note: IM-200BAK does not utilize a condenser thermistor, therefore E9 error will not occur.	Replace condenser thermistor.
EE (EA)	<u>Control Board Error</u> If model data IC is defective, unit stops.	Replace control board.
EE (EC)	<u>Evaporator (Cube Control) Thermistor Error</u> If evaporator thermistor is open or shorted for 2 sec., unit stops.	Replace evaporator thermistor.
EE (Ed)	<u>Water Regulating Valve Error</u> If water regulating valve thermistor detects a temperature below the water regulating valve error detection temperature (Control Board Setting 36), error is displayed but unit continues to operate. Note: IM-200BAK does not utilize a water regulating valve, therefore Ed error will not occur.	Check water regulating valve.  Press the "RESET" button to reset.

## G. Quick Adjustments

### 1. Dimple Diameter

Dimple diameter can be adjusted by the freeze cycle termination temperature setting. The factory default freeze cycle termination temperature setting is  $-22.5^{\circ}\text{C}$ . This produces an approximate dimple diameter size of  $1/4"$  (7 mm). **NOTICE! Do not decrease the freeze cycle termination temperature below  $-23.5^{\circ}\text{C}$  (dimple diameter size of  $3/16"$  (5 mm)).**

#### **a) To increase dimple diameter:**

- 1) Remove front panel.
- 2) Press the "SERVICE 1" button to view the current freeze cycle termination temperature setting.
- 3) Press the "SERVICE 1" button to raise freeze cycle termination temperature setting (Control Board Setting 2). Temperature setting rises in  $.5^{\circ}\text{C}$  increments. The "." in the lower, right corner of the display indicates  $.5^{\circ}\text{C}$ . Default is  $-22.5^{\circ}\text{C}$ . For reference, raising freeze cycle termination temperature setting to  $-19^{\circ}\text{C}$  will result in a dimple diameter of approximately  $3/8"$  (10 mm).
- 4) Once the display returns to "on" (20 seconds), the new setting is saved.

#### **b) To decrease dimple diameter:**

- 1) Remove front panel.
- 2) Press the "SERVICE 2" button to view the current freeze cycle termination temperature setting.
- 3) Press the "SERVICE 2" button to lower freeze cycle termination temperature setting (Control Board Setting 2). Temperature setting lowers in  $.5^{\circ}\text{C}$  increments. The "." in the lower, right corner of the display indicates  $.5^{\circ}\text{C}$ . Default is  $-22.5^{\circ}\text{C}$ . **NOTICE! Do not decrease freeze cycle termination temperature below  $-23.5^{\circ}\text{C}$  (dimple diameter size of  $3/16"$  (5 mm)).**
- 4) Once the display returns to "on" (20 seconds), the new setting is saved.

## 2. Ice Clarity

In hard water conditions, white ice may be produced. In such cases, install a water filter and/or water softener, then follow the instructions below.

- 1) Move the control switch to the "OFF" position, then turn off the power supply.
- 2) Remove the front panel.
- 3) Remove the screw, then move the water tank drain pipe to the drain position. See Fig. 3. Use the screw to secure the water tank drain pipe in the drain position.
- 4) Turn on the power supply, then move the control switch to the "ICE" position.
- 5) Press and hold the "RESET" button for 3 seconds. "1" appears in the display.
- 6) Press the "SERVICE 1" button until "12" appears in the display. Press the "RESET" button. The current icemaking water supply time value flashes in the display. Press the "SERVICE 1" or "SERVICE 2" buttons to change the setting to "66".
- 7) Press the "RESET" button to save the setting and return to the menu.
- 8) Using the same procedure as above, change the full/partial drain setting (Control Board Setting 14) from "1" (partial drain) to "0" (full drain).
- 9) Once the display returns to "on" (20 seconds), the new setting is saved.
- 10) Replace the front panel in its correct position.

Note: If white ice continues to be an issue, set hard water setting water supply time (Control Board Setting 61) to "15". This results in the inlet water valve energizing for 15 seconds part way through the freeze cycle and diluting the water in the water pan. Do not increase this setting beyond 15 seconds; otherwise, freeze cycle times may become long and bridging may occur in the ice storage bin.

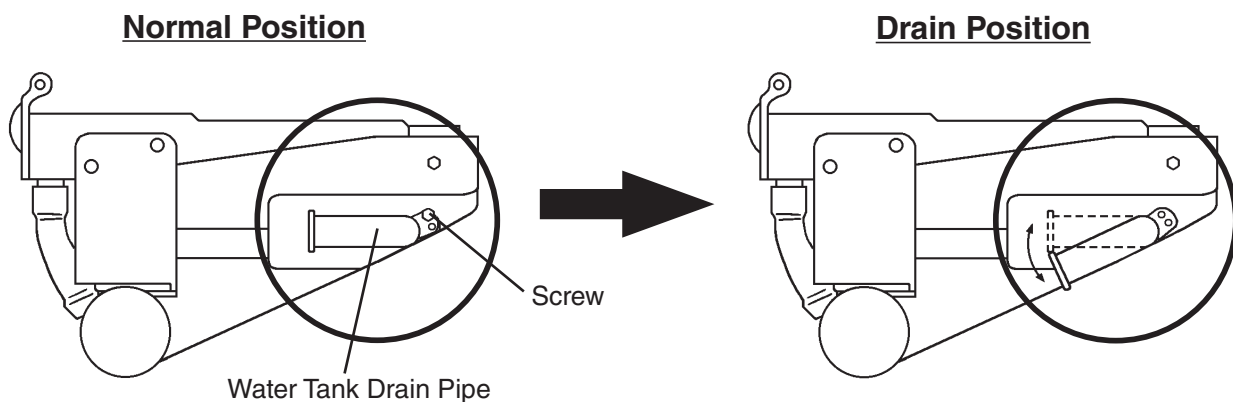

**Fig. 3**

## H. Refrigeration Circuit Service



### R-290 Class A3 Flammable Refrigerant Used

#### **! DANGER**

##### **Risk of Fire or Explosion. Flammable Refrigerant Used.**

- Be sure to follow all Important Safety Information located at the beginning of this manual and at the beginning of section "III.A. Safety Precautions When Servicing."
- Servicing shall be done by trained service personnel with certified competence in handling flammable refrigerants to minimize the risk of possible ignition due to incorrect parts or improper service.
- Confirm that capacitors are discharged: this shall be done in a safe manner to avoid possibility of sparking.
- A dry chemical or CO<sub>2</sub> fire extinguisher should be adjacent to the charging area. You must have a Class B chemical fire extinguisher available at all times.
- When breaking into the refrigerant circuit to make repairs – or for any other purpose – conventional procedures shall be used. However, for flammable refrigerants it is important that best practice be followed, since flammability is a consideration. The following procedure shall be adhered to:
  - safely remove refrigerant following local and national regulations
  - purge the circuit with inert gas
  - evacuate (optional for A2L)
  - purge with inert gas (optional for A2L)
  - open the circuit by cutting or brazing
- Confirm that no live electrical components and wiring are exposed while charging, recovering, or purging the system.
- You must have a combustible gas leak detector in the immediate work area at all times.
- Be sure the area is clear of refrigerant vapor before brazing.
- The refrigerant charge shall be recovered into the correct recovery cylinders if venting is not allowed by local and national codes. For appliances containing flammable refrigerants, the system shall be purged with oxygen-free nitrogen to render the appliance safe for flammable refrigerants. This process might need to be repeated several times. Compressed air or oxygen shall not be used for purging refrigerant systems.

## **! DANGER Continué**

### **Risque De Feu Ou D'Explosion. Fluide Frigorigène Inflammable Utilisé.**

- Assurez-vous de suivre toutes les informations importantes de sécurité qui se trouvent au début du présent manuel et au début de la section «III.A. Précautions de sécurité lors de l'entretien.»
- L'entretien doit être effectué par du personnel formé et certifié pour la manipulation de réfrigérants inflammables afin de réduire au minimum le risque d'inflammation dû à des pièces incorrectes ou à un entretien inadéquat.
- S'assurer que les condensateurs sont déchargés : cette opération doit être effectuée en toute sécurité afin d'éviter tout risque d'étincelle.
- Un extincteur à poudre chimique ou à CO<sub>2</sub> devrait être installé à proximité de la zone de chargement. Un extincteur chimique de classe B doit être disponible à tout moment.
- Pour pénétrer dans le circuit du réfrigérant afin d'effectuer des réparations ou pour toute autre raison, des procédures conventionnelles doivent être utilisées. Toutefois, pour les réfrigérants inflammables, il est important de suivre les meilleures pratiques, car l'inflammabilité est un facteur à prendre en considération. La procédure suivante doit être respectée:
  - éliminer le réfrigérant en toute sécurité conformément aux réglementations locales et nationales
  - purger le circuit avec du gaz inerte
  - évacuer (en option pour A2L)
  - purger avec du gaz inerte (en option pour A2L)
  - ouvrir le circuit par coupure ou brasage
- S'assurer qu'aucun composant ou câblage électrique sous tension n'est exposé lors de la charge, de la récupération ou de la purge du système.
- Un détecteur de fuites de gaz combustible doit se trouver à tout moment dans la zone de travail immédiate.
- Assurez-vous que la zone est exempte de vapeur de réfrigérant avant de procéder au brasage.
- La charge de réfrigérant doit être récupérée dans les bouteilles de récupération appropriées si la ventilation n'est pas autorisée par les normes locales et nationales. Pour les appareils contenant des réfrigérants inflammables, le système doit être purgé avec de l'azote sans oxygène afin de rendre l'appareil inoffensif pour les réfrigérants inflammables. Cette procédure peut être répétée plusieurs fois. L'air comprimé ou l'oxygène ne doivent pas être utilisés pour la purge des systèmes de réfrigération.

## **! WARNING**

- Wear appropriate personal protective equipment (PPE) when servicing the appliance.
- Notify all persons in the immediate area that you are working with a flammable refrigerant.
- Do not use silver alloy or copper alloy containing arsenic.

### a) Refrigerant Recovery

Using proper refrigerant practices, place piercing valves toward the end (crimped area) of the high and low-side process tubes, then recover the refrigerant into an approved container or device.

- 1) Move the control switch to the "OFF" position, then unplug the appliance from the electrical outlet.

### b) Brazing

- 2) Prior to brazing, purge with nitrogen gas for 2 min., flowing at a pressure of 3 to 5 PSIG.  
**⚠ DANGER! For appliances containing flammable refrigerants, the system shall be purged with oxygen-free nitrogen to render the appliance safe for flammable refrigerants. This process might need to be repeated several times. Compressed air or oxygen shall not be used for purging refrigerant systems.**
- 3) Braze/repair/replace damaged component or fittings while purging with nitrogen gas, flowing at a pressure of 3 to 5 PSIG.

#### **NOTICE**

- Do not leave the system open for longer than 15 min. when replacing or servicing parts. The Polyol Ester (POE) oils used in R-290 applications can absorb moisture quickly. Therefore it is important to prevent moisture from entering the system when replacing or servicing parts.
- Always install a new drier every time the sealed refrigeration system is opened. Do not replace the drier until after all other repair or replacement has been made. Install the new drier with the arrow on the drier in the direction of the refrigerant flow.
- When brazing, protect the drier by using a wet cloth to prevent the drier from overheating. Do not allow the drier to exceed 250°F (121°C).

- 4) Use soap bubbles to check for leaks. Raise the pressure using nitrogen gas (190 PSIG). Do not use any refrigerant as a mixture with pressurized air for leak testing.
- 5) Once leak checking is complete, release the nitrogen gas from the system.

### c) Evacuation

- 6) Attach a vacuum pump to the system. Be sure the high-side charging hose is connected to the field-installed high-side access valve.

#### **IMPORTANT**

The vacuum level and vacuum pump may be the same as those for current refrigerants. However, the rubber hose and gauge manifold to be used for evacuation and refrigerant charge should be exclusively for POE oils.

- 7) Turn on the vacuum pump, then open the high-side valve on the gauge manifold. Never allow the oil in the vacuum pump to flow backwards.
- 8) Allow the vacuum pump to pull down to a 29.9" Hg vacuum. Evacuating period depends on pump capacity.

- 9) Close the high-side valve on the gauge manifold.
- 10) Disconnect the gauge manifold hose from the vacuum pump and attach it to a refrigerant service cylinder. Remember to loosen the connection and purge the air from the hose. See the nameplate for the required refrigerant charge. Hoshizaki recommends only virgin refrigerant or reclaimed refrigerant which meets the requirements of AHRI Standard 700 (latest edition) be used.

#### d) Recharge

### ! DANGER

- In addition to conventional charging procedures, the following requirements shall be followed:
  - Ensure that contamination of different refrigerants does not occur when using charging equipment. Hoses or lines shall be as short as possible to minimize the amount of refrigerant contained in them.
  - Cylinders shall be kept in an appropriate position according to the instructions.
  - Ensure that the refrigerating system is earthed (grounded) prior to charging the system with refrigerant.
  - Label the system when charging is complete (if not already).
  - Extreme care shall be taken not to overfill the refrigerating system.
- The system shall be leak-tested on completion of charging but prior to commissioning. A follow up leak test shall be carried out prior to leaving the site.

- En plus des procédures de charge conventionnelles, les exigences suivantes doivent être respectées :
  - S'assurer qu'aucune contamination de différents réfrigérants ne se produit lors de l'utilisation de l'équipement de charge. Les tuyaux ou conduites doivent être aussi courts que possible afin de minimiser la quantité de réfrigérant qu'ils contiennent.
  - Les bouteilles doivent être maintenues dans une position appropriée conformément aux instructions.
  - S'assurer que le système de réfrigération soit mis à la terre avant de charger le système avec du réfrigérant.
  - Étiqueter le système lorsque la charge est terminée (si cela n'a pas déjà été fait).
  - Il faut veiller à ne pas trop remplir le système de réfrigération.
- Avant de recharger le système, celui-ci doit être testé sous pression avec le gaz de purge approprié. Le système doit être soumis à un essai de fuite à la fin de la charge, mais avant la mise en service. Un test de contrôle de fuite doit être effectué avant de quitter le site.

- 11) R-290 can be charged in either the liquid or vapor state. Liquid charge is preferred. If refrigerant charging is done in the liquid state, place the service cylinder on the scales; **if the service cylinder is not equipped with a dip tube, invert the service cylinder, then place it on the scales.** Open the high-side valve on the gauge manifold.

- 12) Allow the system to charge with liquid until the proper charge weight is met.
- 13) Close the high-side valve on the gauge manifold. If charging is complete, skip to step 10.
- 14) If necessary, add any remaining charge to the system through the low-side.  
**NOTICE! To prevent compressor damage, use a throttling valve or liquid dispensing device to add the remaining liquid charge through the low-side refrigerant access valve with the compressor running.** Close the refrigerant cylinder valve and let the low-side refrigerant equalize to the system, then close the low-side manifold gauge.
- 15) Pinch off (crimp down) the process tubes just below the piercing valves.
- 16) Remove the piercing valves. Cut the process tubes to remove the piercing valve holes.
- 17) Confirm there are no leaks from the pinched off process tubes, then braze the process tubes closed. **▲ DANGER! Be sure there is no refrigerant leak before brazing.**
- 18) Use a combustible gas leak detector or soap bubbles to check for leaks again.
- 19) Place red sleeves over the process tubes.
- 20) Plug the appliance back into the electrical outlet

## I. Component Service Information



### R-290 Class A3 Flammable Refrigerant Used

#### **! DANGER**

##### **Risk of Fire or Explosion. Flammable Refrigerant Used.**

- Be sure to follow all Important Safety Information located at the beginning of this manual and at the beginning of section "III.A. Safety Precautions When Servicing."
- Component parts shall be replaced with like components. So as to minimize the risk of possible ignition due to incorrect parts.
- This appliance should be diagnosed and repaired only by qualified service personnel to reduce the risk of death, electric shock, serious injury, or fire.
- Repair and maintenance to electrical components shall include initial safety checks and component inspection procedures. If a fault exists that could compromise safety, then no electrical supply shall be connected to the circuit until it is satisfactorily dealt with. If the fault cannot be corrected immediately but it is necessary to continue operation, an adequate temporary solution shall be used. This shall be reported to the owner of the equipment, so all parties are advised.
- Confirm that capacitors are discharged: this shall be done in a safe manner to avoid possibility of sparking.
- Confirm that no live electrical components and wiring are exposed while charging, recovering, or purging the system.
- Confirm that there is continuity of earth bonding (grounding).

## ! DANGER Continué

### Risque D'Incendie ou D'Explosion. Fluide Frigorigène Inflammable Utilisé.

- Assurez-vous de suivre toutes les informations importantes de sécurité qui se trouvent au début du présent manuel et au début de la section «III.A. Précautions de sécurité lors de l'entretien.»
- Les pièces doivent être remplacées par des pièces similaires, de manière à réduire au minimum le risque d'inflammation dû à des pièces incorrectes.
- Cet appareil ne doit être diagnostiqué et réparé que par un personnel qualifié afin de réduire les risques de mort, d'électrocution, de blessures graves ou d'incendie.
- La réparation et l'entretien des composants électriques incluent les contrôles de sécurité initiaux et les procédures d'inspection des composants. En cas de défaut susceptible de compromettre la sécurité, aucune alimentation électrique ne doit être connectée au circuit tant que le problème n'a pas été résolu de manière satisfaisante. Si le défaut ne peut être corrigé immédiatement mais qu'il est nécessaire de poursuivre l'exploitation, une solution temporaire adéquate doit être utilisée. Cela doit être signalé au propriétaire de l'équipement, afin que toutes les parties soient informées.
- S'assurer que les condensateurs sont déchargés:cette opération doit être effectuée en toute sécurité afin d'éviter tout risque d'étincelle.
- S'assurer qu'aucun composant ou câblage électrique sous tension n'est exposé lors de la charge, de la récupération ou de la purge du système.
- S'assurer de la continuité de la mise à la terre.

### **NOTICE**

When replacing a component listed below, see the notes to help ensure proper operation.

Component	Notes
Compressor	Install a new start capacitor, run capacitor, and start relay.
Thermostatic Expansion Valve	<ul style="list-style-type: none"> <li>• Attach the thermostatic expansion valve bulb to the suction line in the same location as the previous bulb.</li> <li>• The bulb should be between the 10 and 2 o'clock positions on the tube.</li> <li>• Secure the bulb with the clamp and holder, then insulate it.</li> </ul>
Hot Gas Valve	<ul style="list-style-type: none"> <li>• Replace the strainer if applicable.</li> <li>• Use copper tube of the same diameter and length when replacing valve lines.</li> </ul>
Fan Motor	Install a new capacitor.
Pump Motor	Install a new capacitor.
Actuator Motor	Install a new capacitor.
Evaporator (Cube Control) Thermistor	<ul style="list-style-type: none"> <li>• Attach the new thermistor to the same location on the evaporator as the previous thermistor.</li> <li>• Smoothly fill the recessed area of the thermistor holder with high thermal conductive type sealant. KE-4560 RTV (manufactured by ShinEtsu Silicones), or equivalent are recommended.</li> <li>• Attach the new thermistor in position on the evaporator and press down the thermistor holder over the thermistor.</li> <li>• Be very careful to prevent damage to the leads.</li> </ul>

## V. Maintenance

The maintenance schedule below is a guideline. More frequent maintenance may be required depending on water quality, the appliance's environment, and local sanitation regulations

### WARNING

- Only qualified service technicians should service the appliance.
- To reduce the risk of electric shock, do not touch the control switch or plug with damp hands. Make sure the control switch is in the "OFF" position before plugging in or unplugging the appliance.
- Move the control switch to the "OFF" position and unplug the appliance from the electrical outlet before servicing.
- **CHOKING HAZARD:** Ensure all components, fasteners, and thumbscrews are securely in place after any maintenance is done to the appliance. Make sure that none have fallen into the storage bin.

### Maintenance Schedule

Frequency	Area	Task
Daily	Scoop	Clean the ice scoop using a neutral cleaner. Rinse thoroughly after cleaning.
Bi-Weekly	Air Filters	Inspect. Wash with warm water and neutral cleaner if dirty.
Monthly	External Water Filters	Check for proper pressure and change if necessary.
	Icemaker Exterior	Wipe down with a clean, soft cloth. Use a damp cloth containing a neutral cleaner to wipe off oil or dirt build up. Clean any chlorine staining (rust colored spots) using a non-abrasive cleanser.
Yearly	Icemaker and Dispenser Unit/Ice Storage Bin Liner	Clean and sanitize per the cleaning and sanitizing instructions provided in the instruction manual or maintenance label on the appliance.
	Water Supply Inlet	Close the icemaker water supply line shut-off valve and drain the water system. Clean the water supply inlet screen.
	Condenser	Inspect. Clean if necessary by using a brush or vacuum cleaner. More frequent cleaning may be required depending on location.
	Water Hoses	Inspect the water hoses and clean/replace if necessary.

## VI. Preparing the Appliance for Periods of Non-Use

### **⚠ DANGER**

#### **Risk of Fire or Explosion. Flammable Refrigerant Used.**

- Be sure to follow all Important Safety Information located at the beginning of this manual and at the beginning of section "III.A. Safety Precautions When Servicing."
- Only qualified service technicians should service this appliance.
- The appliance shall be stored in an area where the room size corresponds to the room area as specified for operation. See the nameplate or instruction manual for Minimum Room Floor Area.
- The appliance shall be stored in a room without continuously operating open flames (for example an operating gas appliance) or other potential ignition sources (for example an operating electric heater, hot surfaces).

#### **Risque D'Incendie ou D'Explosion. Fluide Frigorigène Inflammable Utilisé.**

- Assurez-vous de suivre toutes les informations importantes de sécurité qui se trouvent au début du présent manuel et au début de la section «III.A. Précautions de sécurité lors de l'entretien.»
- Seuls des techniciens de service qualifiés doivent installer et entretenir l'appareil.
- L'appareil doit être conservé dans une zone où la taille de la pièce correspond à la surface de la pièce spécifiée pour le fonctionnement.
- L'appareil doit être entreposé dans un local ne contenant pas de sources d'inflammation permanentes (flammes nues, appareil à gaz ou dispositif de chauffage électrique en fonctionnement, par exemple).

### **NOTICE**

- During extended periods of non-use, extended absences, or in sub-freezing temperatures, follow the instructions below to reduce the risk of costly water damage.
- When the appliance is not used for two or three days under normal conditions, it is sufficient to move the control switch to the "OFF" position.

## **1. Remove the water from the icemaker water supply line:**

- 1) Remove the front panel.
- 2) Move the control switch to the "OFF" position.
- 3) Close the icemaker water supply line shut-off valve and open the icemaker water supply line drain valve. See Fig. 4.
- 4) Allow the icemaker water supply line to drain by gravity.
- 5) Attach compressed air or carbon dioxide supply to the icemaker water supply line drain valve.
- 6) Move the control switch to the "ICE" position.
- 7) Blow the icemaker water supply line out using compressed air or carbon dioxide.

## **2. Drain the water tank:**

- 1) Move the control switch to the "OFF" position and then unplug the appliance.
- 2) Remove the top panel, top insulation, and top sheet.
- 3) Remove the screw, and move the tank drain pipe to the drain position. See Fig. 3.
- 4) Replace the top sheet, top insulation, and top panel.
- 5) Close the icemaker water supply line drain valve.
- 6) Plug in the appliance and then move the control switch to the "ICE" position.
- 7) Press the "RESET" button. See Fig. 2. The water tank will start to open.  
Note: This procedure is necessary to protect the icemaker from freezing up at subfreezing temperatures.
- 8) Move the control switch to the "OFF" position and then unplug the appliance when the water tank is fully opened.
- 9) Remove the top panel, top insulation, and top sheet.
- 10) Move the tank drain pipe to the normal position and then secure it with the screw.  
See Fig. 3.
- 11) Replace the top sheet, top insulation, top panel, and front panel.

## VII. Decommissioning and Disposal



### R-290 Class A3 Flammable Refrigerant Used

#### **! DANGER**

##### **Risk of Fire or Explosion. Flammable Refrigerant Used.**

- Be sure to follow all Important Safety Information located at the beginning of this manual and at the beginning of section "III.A. Safety Precautions When Servicing."
- Servicing shall be done by trained service personnel with certified competence in handling flammable refrigerants to minimize the risk of possible ignition due to improper service.
- Follow handling instructions carefully in compliance with national regulations.
- Dispose of properly in accordance with federal or local regulations.
- Do not puncture refrigerant tubing. Risk of fire or explosion due to puncture of refrigerant tubing; follow handling instructions carefully.
- When removing refrigerant from a system, either for servicing or decommissioning, it is recommended good practice that all refrigerants are removed safely.
- When transferring refrigerant into cylinders, ensure that only appropriate refrigerant recovery cylinders are employed. Ensure that the correct number of cylinders for holding the total system charge is available. All cylinders to be used are designated for the recovered refrigerant and labeled for that refrigerant (i.e., special cylinders for the recovery of refrigerant). Cylinders shall be complete with pressure-relief valve and associated shut-off valves in good working order. Empty recovery cylinders are evacuated and, if possible, cooled before recovery occurs.
- The recovery equipment shall be in good working order with a set of instructions concerning the equipment that is at hand and shall be suitable for the recovery of all appropriate refrigerants including, when applicable, flammable refrigerants. In addition, a set of calibrated weighing scales shall be available and in good working order. Hoses shall be complete with leak-free disconnect couplings and in good condition. Before using the recovery machine, check that it is in satisfactory working order, has been properly maintained and that any associated electrical components are sealed to prevent ignition in the event of a refrigerant release. Consult manufacturer if in doubt.
- The recovered refrigerant shall be returned to the refrigerant supplier in the correct recovery cylinder, and the relevant waste transfer note arranged. Do not mix refrigerants in recovery units and especially not in cylinders.
- If compressors or compressor oils are to be removed, ensure that they have been evacuated to an acceptable level to make certain that flammable refrigerant does not remain within the lubricant. The evacuation process shall be carried out prior to returning the compressor to the suppliers. Only electric heating to the compressor body shall be employed to accelerate this process. When oil is drained from a system, it shall be carried out safely.

## **! DANGER Continué**

### **Risque D'Incendie ou D'Explosion. Fluide Frigorigène Inflammable Utilisé.**

- Assurez-vous de suivre toutes les informations importantes de sécurité qui se trouvent au début du présent manuel et au début de la section «III.A. Précautions de sécurité lors de l'entretien.»
- L'entretien doit être effectué par du personnel formé et certifié pour la manipulation de réfrigérants inflammables afin de réduire au minimum le risque d'inflammation dû à un entretien inadéquat.
- Suivre attentivement les instructions de manutention conformément aux règlements nationaux.
- Mettre au rebut conformément aux conformément aux règlements fédéraux ou locaux.
- Ne pas perforer la conduite de fluide frigorigène. Risque d'incendie ou d'explosion en cas de perforation d'une canalisation de fluide frigorigène; suivez attentivement les instructions de manutention.
- Lors de l'élimination du réfrigérant d'un système, que ce soit pour l'entretien ou la mise hors service, il est recommandé de veiller à ce que tous les réfrigérants soient éliminés en toute sécurité.
- Lors du transfert de réfrigérant dans des bouteilles, veillez à ce que seules des bouteilles de récupération de réfrigérant appropriées soient utilisées. Assurez-vous que le nombre de bouteilles nécessaires pour contenir la charge totale du système est disponible. Toutes les bouteilles à utiliser sont désignées pour le réfrigérant récupéré et étiquetées pour ce réfrigérant (c'est-à-dire des bouteilles spéciales pour la récupération du réfrigérant). Les bouteilles doivent être équipées d'une soupape de surpression et de soupapes d'arrêt associées en bon état de fonctionnement. Les bouteilles de récupération vides sont évacuées et, si possible, refroidies avant la récupération.
- L'équipement de récupération doit être en bon état de fonctionnement, accompagné d'un ensemble d'instructions concernant l'équipement disponible et doit être adapté à la récupération de tous les réfrigérants appropriés, y compris, le cas échéant, les réfrigérants inflammables. En outre, un ensemble de balances étalonnées doit être disponible et en bon état de fonctionnement. Les tuyaux doivent être complets, équipés de raccords de déconnexion sans fuite et en bon état. Avant d'utiliser la machine de récupération, vérifiez qu'elle est en bon état de fonctionnement, qu'elle a été correctement entretenue et que tous les composants électriques associés sont scellés pour éviter toute inflammation en cas de fuite de réfrigérant. Consulter le fabricant en cas de doute.
- Le réfrigérant récupéré doit être renvoyé au fournisseur de réfrigérant dans la bouteille de récupération appropriée et le bon de transfert de déchets correspondant doit être établi. Ne mélangez pas les réfrigérants dans les unités de récupération et surtout pas dans les bouteilles.
- Si les compresseurs ou les huiles de compresseur doivent être retirés, assurez-vous qu'ils ont été évacués à un niveau acceptable afin de s'assurer qu'il ne reste pas de réfrigérant inflammable dans le lubrifiant. Le processus d'évacuation doit être effectué avant que le compresseur ne soit renvoyé aux fournisseurs. Seul le chauffage électrique du boîtier du compresseur doit être utilisé pour accélérer ce processus. Lorsque l'huile est vidangée d'un système, cette opération doit être effectuée en toute sécurité.

The appliance contains refrigerant and must be disposed of in accordance with applicable national, state, and local codes and regulations. Refrigerant must be recovered and safely disposed of by properly trained service personnel.

Before carrying out this procedure, it is essential that the technician is completely familiar with the equipment and all its detail. It is recommended good practice that all refrigerants are recovered safely. Prior to the task being carried out, an oil and refrigerant sample shall be taken in case analysis is required prior to re-use of recovered refrigerant. It is essential that electrical power is available before the task is commenced.

- Become familiar with the equipment and its operation.
- Isolate the system electrically.
- **Before attempting the procedure, ensure that:**
  - mechanical handling equipment is available, if required, for handling refrigerant cylinders
  - all personal protective equipment is available and being used correctly
  - the recovery process is supervised at all times by a competent person
  - recovery equipment and cylinders conform to the appropriate standards
- Pump down refrigerant system, if possible.
- If a vacuum is not possible, make a manifold so that refrigerant can be removed from various parts of the system.
- Make sure that cylinder is situated on the scales before recovery takes place.
- Start the recovery machine and operate in accordance with instructions.
- Do not overfill cylinders (no more than 80% volume liquid charge).
- Do not exceed the maximum working pressure of the cylinder, even temporarily.
- When the cylinders have been filled correctly and the process completed, make sure that the cylinders and the equipment are removed from site promptly and all isolation valves on the equipment are closed off.
- Recovered refrigerant shall not be charged into another refrigerating system unless it has been cleaned and checked.

**Follow the steps below for decommissioning and disposal:**

**1. Recovery**

- 1) Recover the refrigerant, and safely dispose of the refrigerant.
- 2) Evacuate the appliance.
- 3) Purge the refrigeration system with nitrogen.
- 4) Cut out the compressor and drain and dispose of the compressor oil. Compressor oils are to be removed, ensure that they have been evacuated to an acceptable level to make certain that flammable refrigerant does not remain within the lubricant. Dispose of compressor and compressor oil in compliance with national, state, and local codes and regulations.
- 5) Purge the refrigeration system with nitrogen.

**2. Labeling**

Equipment shall be labeled stating that it has been decommissioned and emptied of refrigerant. The label shall be dated and signed. For appliances containing flammable refrigerant, ensure that there are labels on the equipment stating the equipment contains flammable refrigerant.

## VIII. Technical Information

We reserve the right to make changes in specifications and design without prior notice.

### A. Specification and Performance Data Sheets

#### 1. IM-200BAK

##### Specification Sheet

AC SUPPLY VOLTAGE (V/Hz/PH)	~115-120/60/1	
AMPERAGE (A)	5.0	
MINIMUM CIRCUIT AMPACITY (A)	15	
MAXIMUM FUSE SIZE (A)	15	
ELECTRIC & WATER CONSUMPTION (Wtr/Air)(°C/°F)	32/21 (90/70)	21/10 (70/50)
ELECTRIC W (kWH/100 lbs.)	390 (6.5)	360 (4.68)
WATER gal./24HR (gal./100 lbs.)	34.5 (23)	35.8 (19)
SHAPE OF ICE	Square Cube	
ICE PRODUCTION PER CYCLE (lbs/kg)	80 pcs, 4.3 (2)	
HARVEST RATE (lbs/day)	≤1000	
APPROXIMATE STORAGE CAPACITY (lbs/kg)	75 (34)	
CUBE CONTROL SYSTEM	Thermistor, Timer	
HARVESTING CONTROL SYSTEM	Thermistor, Hot Gas, Timer	
ICE MAKING WATER CONTROL	Timer, Overflow Pipe	
BIN CONTROL SYSTEM	Mechanical Lever Switch and Timer	
REFRIGERANT CHARGE (g/oz.)	R290, 125 (4.4)	
FOAM BLOWING AGENT	HFO 1233zd(E)	
DESIGN PRESSURE (PSIG/kPa)	HI-300 (2069) LO-130 (896)	
MINIMUM ROOM FLOOR AREA m <sup>2</sup> (ft <sup>2</sup> )	6.0 (64.4)	

##### Performance Data Sheet

APPROXIMATE ICE PRODUCTION PER 24 HR.	AMBIENT TEMP. (°F/°C)	WATER TEMP. (°F/°C)					
		50/10		70/21		90/32	
	70/21	<b>186</b>	84	175	80	171	78
	80/27	178	81	162	73	163	74
	90/32	175	80	<b>150</b>	68	149	68
lbs./day (kg./day)	100/38	178	81	150	68	<b>148</b>	67
APPROXIMATE ELECTRIC CONSUMPTION	70/21	<b>360</b>		369		395	
	80/27	367		380		414	
	90/32	369		<b>390</b>		421	
watts	100/38	379		397		<b>450</b>	
APPROXIMATE WATER CONSUMPTION PER 24 HR.	70/21	<b>36</b>	0.14	35	0.13	32	0.12
	80/27	36	0.13	35	0.13	31	0.12
	90/32	35	0.13	<b>35</b>	0.13	31	0.12
gal./day (m <sup>3</sup> /day)	100/38	34	0.13	34	0.13	<b>27</b>	0.10
FREEZING CYCLE TIME	70/21	<b>29.2</b>		30.7		33.1	
	80/27	30.4		32.8		35.3	
	90/32	30.7		<b>34.5</b>		36.9	
min.	100/38	31.3		35.0		<b>39.2</b>	
HARVEST CYCLE TIME	70/21	<b>4.7</b>		4.4		4.1	
	80/27	4.4		3.9		3.7	
	90/32	4.4		<b>3.4</b>		3.2	
min.	100/38	3.9		3.4		<b>3.0</b>	
HEAD PRESSURE	70/21	<b>154</b>	10.8	170	11.9	185	13.0
	80/27	166	11.7	190	13.4	202	14.2
	90/32	170	11.9	<b>207</b>	14.6	221	15.5
PSIG (kg/cm <sup>2</sup> G)	100/38	171	12.0	210	14.8	<b>234</b>	16.5
SUCTION PRESSURE	70/21	<b>40</b>	2.8	41	2.9	42	3.0
	80/27	41	2.9	43	3.0	44	3.1
	90/32	41	2.9	<b>44</b>	3.1	45	3.2
PSIG (kg/cm <sup>2</sup> G)	100/38	41	2.9	44	3.1	<b>46</b>	3.2
TOTAL HEAT OF REJECTION FROM CONDENSER	3,800 BTU/h [AT 90°F (32°C) / WT 70°F (21°C)]						
TOTAL HEAT OF REJECTION FROM COMPRESSOR	500 BTU/h [AT 90°F (32°C) / WT 70°F (21°C)]						

# B. Wiring Diagram

## 1. IM-200BAK

