



OPERATING & SERVICE PARTS MANUAL
700ES ENERGY SMART WRAPPER
SERIES D & E



Revised 2021

READ ALL INSTRUCTIONS CAREFULLY BEFORE OPERATING EQUIPMENT

TABLE OF CONTENTS



Machine Technology & Components	3
Preliminary Setup	5
Recommended Maintenance	6
Troubleshooting	7
Heater Control Board Assembly.....	8
Service Parts Information	9



ENERGY SMART® TECHNOLOGY

- The Energy Smart® Wrapper is an innovative system that incorporates an “Instant On” seal plate with the ability to go from ambient to sealing temperature in 3 seconds. The high speed seal plate, in combination with a photoeye actuator, allows the operator to seal a product on demand and to save energy when the wrapper is not in use.
- As a part of our quality procedures, the seal plate has been tested.
- Due to the advancement of this new technology, it is important to maintain the non-stick cover in good condition. It is recommended to replace the cover at least once every three months to protect the seal plate and maintain a sanitary surface.

HOT ROD HEAT UP

- With the film properly mounted and threaded, the wrapper is ready to be powered up.
- After plugging in the power cord, toggle the power switch (1) located on the back of the electrical box to the ON position.
- The hot rod (2) will require approximately 12 minutes to warm up before it reaches cutting temperature.
- CAUTION: When the wrapper is on the rod will remain hot at all times.

PHOTOEYE ACTUATED HEATER

- The seal plate of the wrapper (3) cycles on when the photoeye is triggered. Triggering the photoeye occurs when a package is placed on the seal plate.
- This feature ensures that the seal plate will consume energy only when there is a demand by the operator.

ELECTRICAL REQUIREMENT

- The Model 700ES requires 115 volts, 15A Circuit.

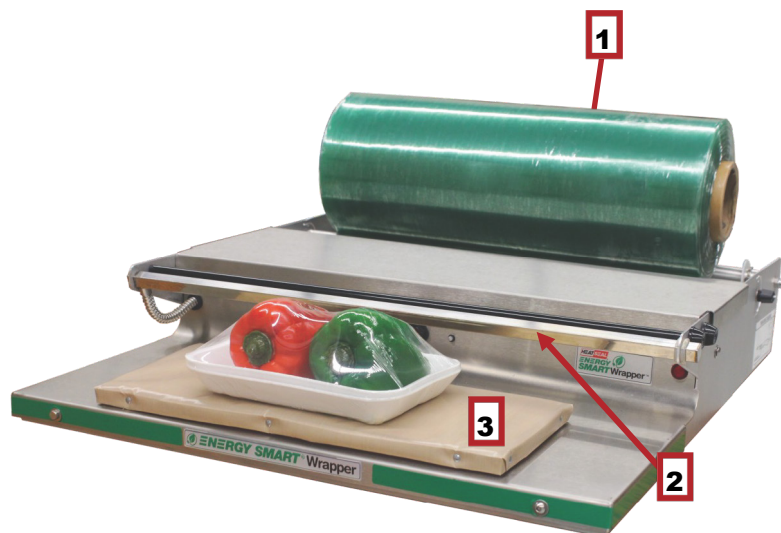

STAINLESS STEEL BRIDGE

- The stainless steel bridge is **not** recommended as a cutting surface and **should not** be used as one.

INDICATOR LIGHT

- The LED light near the center of the unit (2) illuminates to indicate that the heat cycle is in process. The light will turn yellow while the plate is heating and then red when the plate reaches sealing temperature.

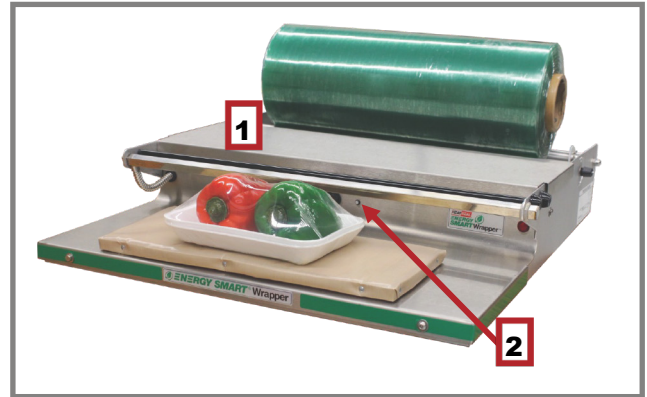

GFCI

- The GFCI (3) is located on the rear surface of the unit. The GFCI may need to be reset if the wrapper gets wet or other ground faults arise. Do not reset the GFCI, if visible seal plate damage is present.

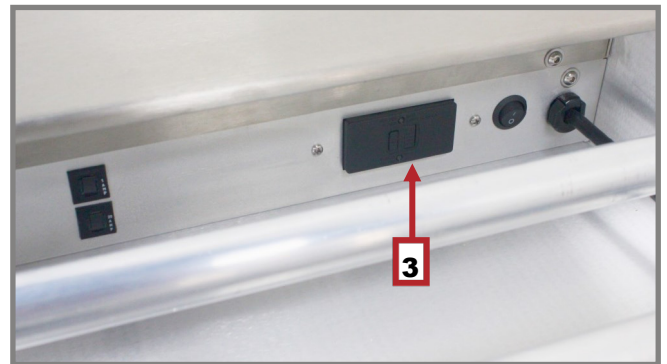

THERMISTOR TEMPERATURE CONTROL

- Due to the rapid response of the seal plate and residual heat that can remain from previous cycles, a thermistor is incorporated as a temperature control device. The seal cycle can be shorter than 3 seconds when residual heat is present in the seal plate. The thermistor, located within the seal plate, regulates the temperature of the seal plate to ensure that the temperature peaks at 370°F.

FILM THREADING

- Film threading is important to achieve proper film tensioning. Proper film tensioning allows for the easiest cutting of film.
- Facing the tension knob (1) side of the machine, the film should come off the roll counter-clockwise and route down and between the two rollers. The film goes under the wrapping bridge and rests on top of the black retainer rod.
- The black tension knob can be adjusted for loose (rotate counter clockwise) or tight (rotate clockwise) tension on the film.
- A threading diagram is located on each unit under the tension knob.

ADJUSTING FOR DIFFERENT WIDTH FILMS

- Slide the white film guides (2) and squeeze the tensioning clips (3) (one on each side of film roll) to center it.

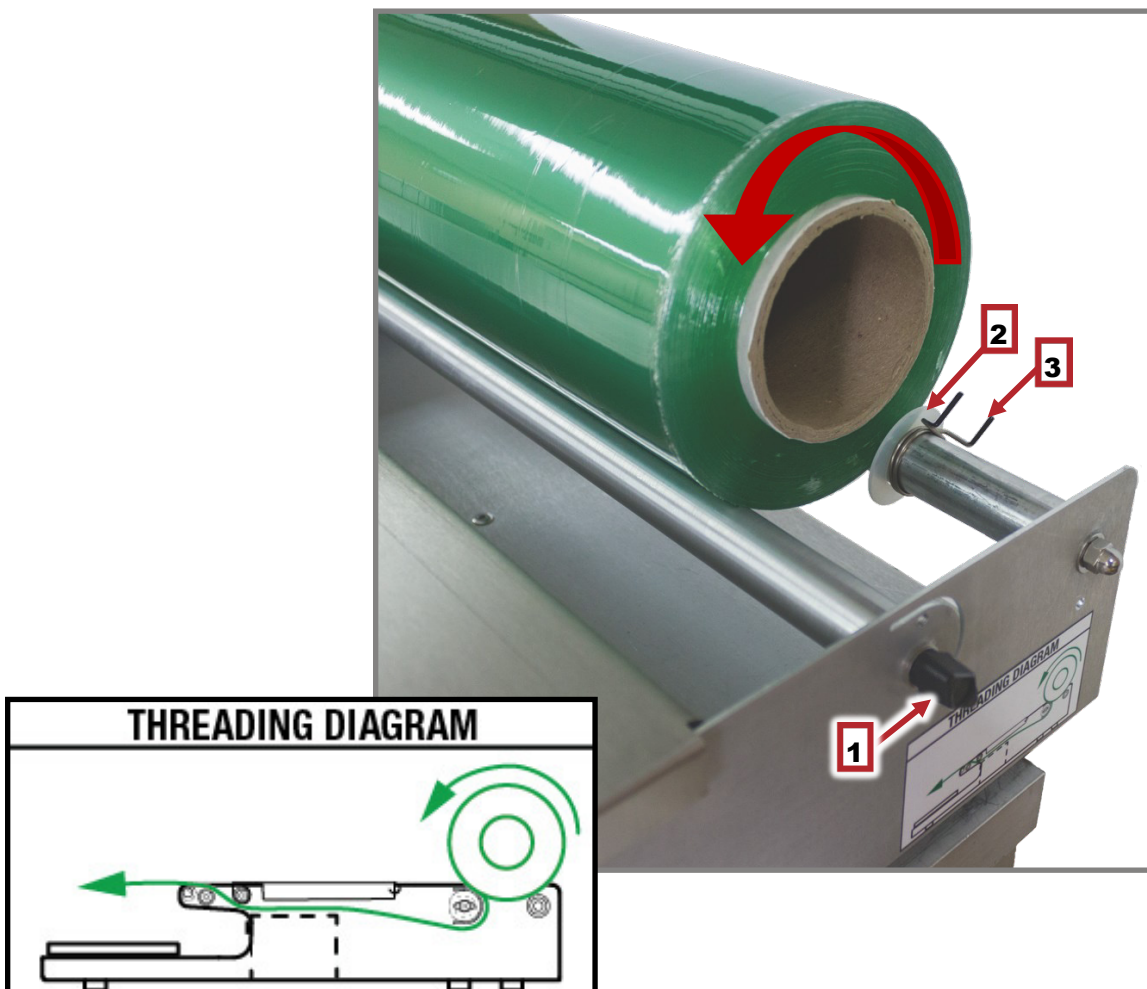

RECOMMENDED MAINTENANCE



- **MAKE SURE TO TURN OFF THE UNIT, UNPLUG AND LET THE MACHINE COOL DOWN BEFORE CLEANING ***

NON-STICK COVER & SEAL PLATE

- The seal plate can be cleaned, as needed, with a mild spray degreaser. This should be applied to a soft cloth or paper towel and then wiped on the plate while cold. **DO NOT WASH DOWN SEAL PLATE OR SPRAY ANY LIQUIDS DIRECTLY ONTO THE PLATE.**
- Replace covers as needed (approximately every 3 months).
- Polyamide Film Wrap seals & protects seal plate from moisture

CUT OFF ROD

- ① Make sure that the unit is turned off and the cut off rod is cool to the touch.
 - ② Cover the unit with paper towels to protect it from overspray and debris.
- Spray the cut-off rod generously with an FDA approved “Degreaser.”
 - After soaking for a few minutes, lightly scrub the surface of the Cut-off rod with a nylon based product (Scotch-Brite™).
 - Wipe the surface clean of debris and residue with clean paper towels or cloths and repeat as needed.

CLEANING THE UNIT

- The 700ES can be wiped down using mild cleaning detergent and a soft cloth or paper towels. **DO NOT HOSE DOWN OR SUBMERGE THE UNIT.**

TROUBLESHOOTING



Symptom	Possible Solution
Machine has no power.	Verify the unit is plugged into a 15 Amp circuit, and the Power Switch is set to the "ON" position.
	GFCI Tripped (Red LED on GFCI will be illuminated and rectangular button labeled "RESET" will be popped out) Press & hold the reset button for (3) seconds to reset. If GFCI does not reset, contact Heat Seal Technical Support.
	No power from outlet that machine is plugged into.
	Loose/disconnected wire inside electrical panel.
Seal Plate does not heat.	Failed photoeye—Contact Heat Seal Technical Support for troubleshooting tips.
	Failed circuit board—Contact Heat Seal Technical Support for troubleshooting tips.
	Failed seal plate—Contact Heat Seal Technical Support for troubleshooting tips.
	Tripped 20A circuit breaker--A tripped circuit breaker will have a white exposed top. Push the circuit breaker tab back in to reset. If breaker cannot be reset contact Heat Seal Technical Support.
	Loose/disconnected wire inside electrical panel.
Cutoff Rod does not heat.	Failed cutoff rod--With power turned off, disconnect both wires of the rod from the terminal block. Check resistance between the two wires. A good rod will read between 40-500 Ω . A measurement outside this range indicates a bad hot rod that needs replaced.
	Tripped 1A circuit breaker--A tripped circuit breaker will have a white exposed top. Push the circuit breaker tab back in to reset. If breaker cannot be reset, contact Heat Seal Technical Support.
	Loose/disconnected wire inside electrical panel.
Film Cutting Difficulty	Film buildup on rod--Clean using nylon based product such as Scotch-Brite.
	Bent cutoff rod--Replace cutoff rod if bent.

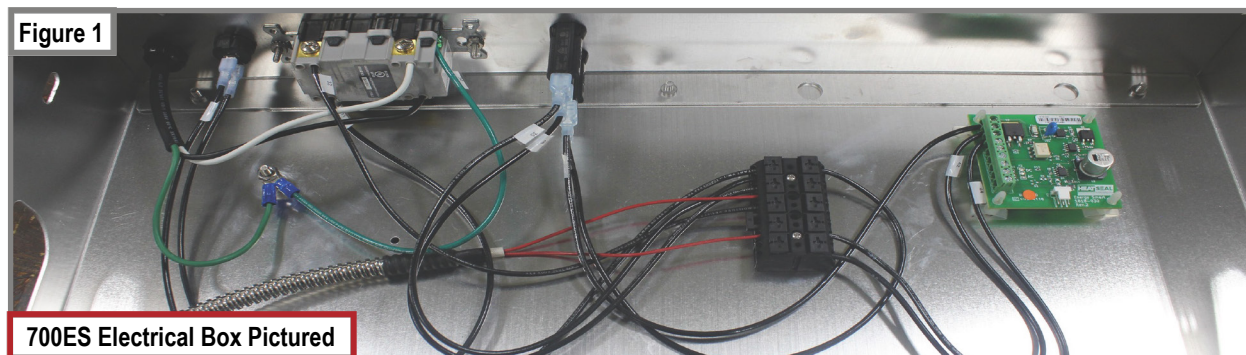

HEATER CONTROL BOARD ASSEMBLY

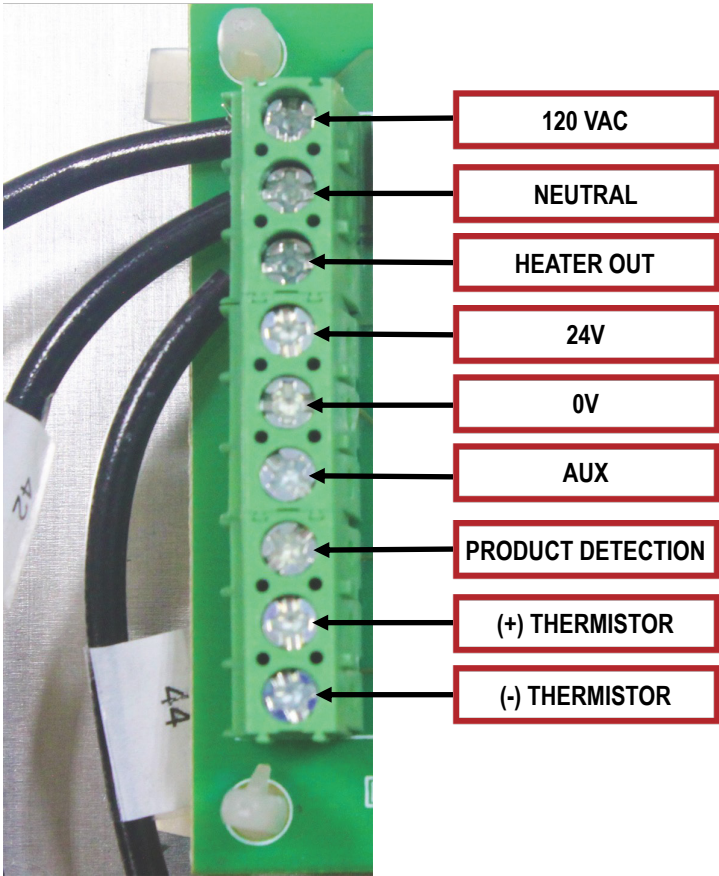

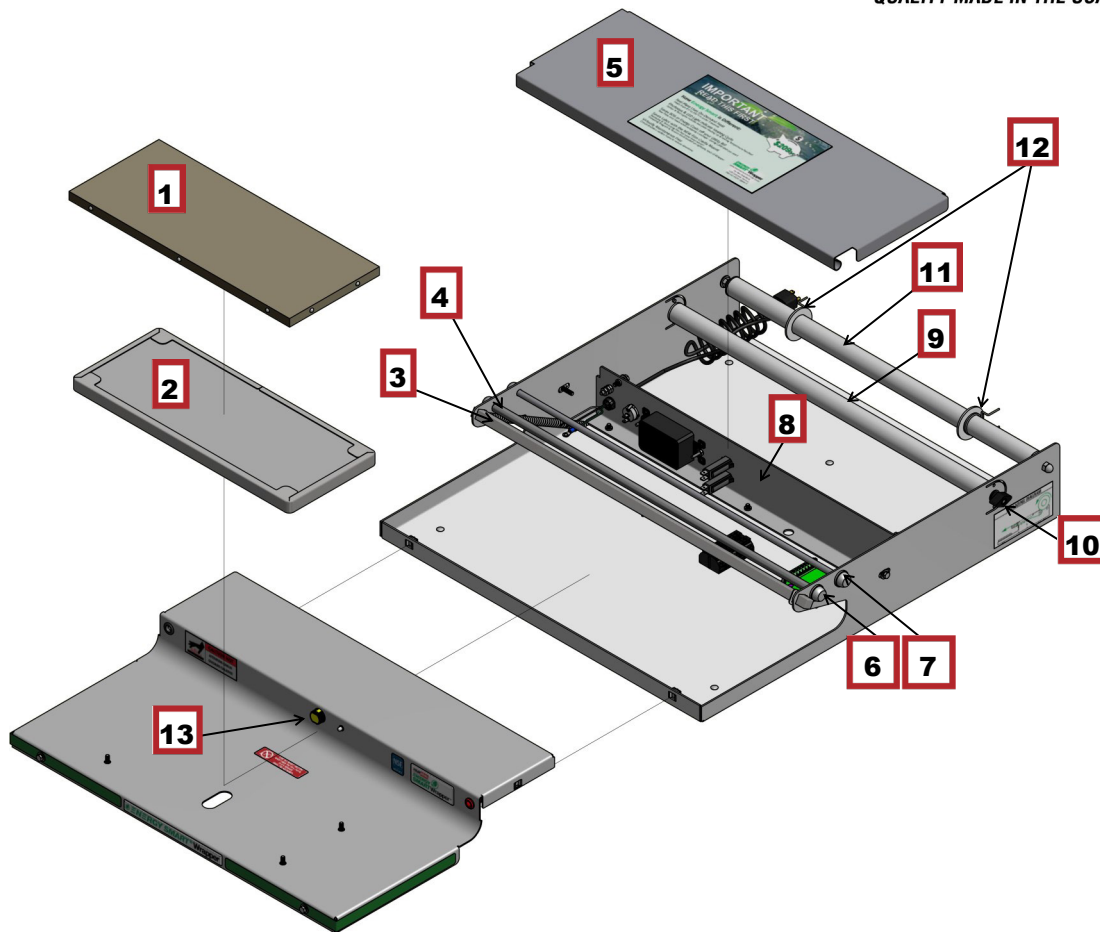

BILL OF MATERIALS FOR MAJOR SUB-ASSEMBLIES

ITEM	QTY	PART NUMBER	DESCRIPTION
1	1	5901-011	Non-stick Cover, 6 x 15
2	1	6137-338	Replacement 6 x 15 Seal Plate Kit, Series D & E
3	1	6137-094	<i>Hot Rod Replacement Kit</i> Includes: (1) Square Cutoff Rod, (1) Rubber Grommet, (1) Screw, #8-32 x 3/8" Long, (1) Retainer, Cutoff Rod 1/2" sq.
4	1	6340-064	<i>Vinyl Replacement Kit</i> Includes: (1) Film Retainer, (2) Black Plastic Shaft Retainer
5	1	6340-066	<i>Bridge Replacement Kit</i> Includes: (1) Stainless Steel Wrapping Bridge, (1) Stainless Steel Rod, (2) Black Plastic Retainer
6	1	6341-009	Stainless Steel Rod
7	1	6340-063	<i>Replacement Cap Kit</i> Includes: (2) Black Plastic Shaft Retainer
8			Electrical Box Assembly (See Page 10)
9	1	6341-029	Tensioning Roller Kit
10	1	2145-052	Tensioning Knob
11	1	6341-031	Idle Roller Kit
12	1	6341-032	Film Centering Device Kit
13	1	1872-133	Photoeye

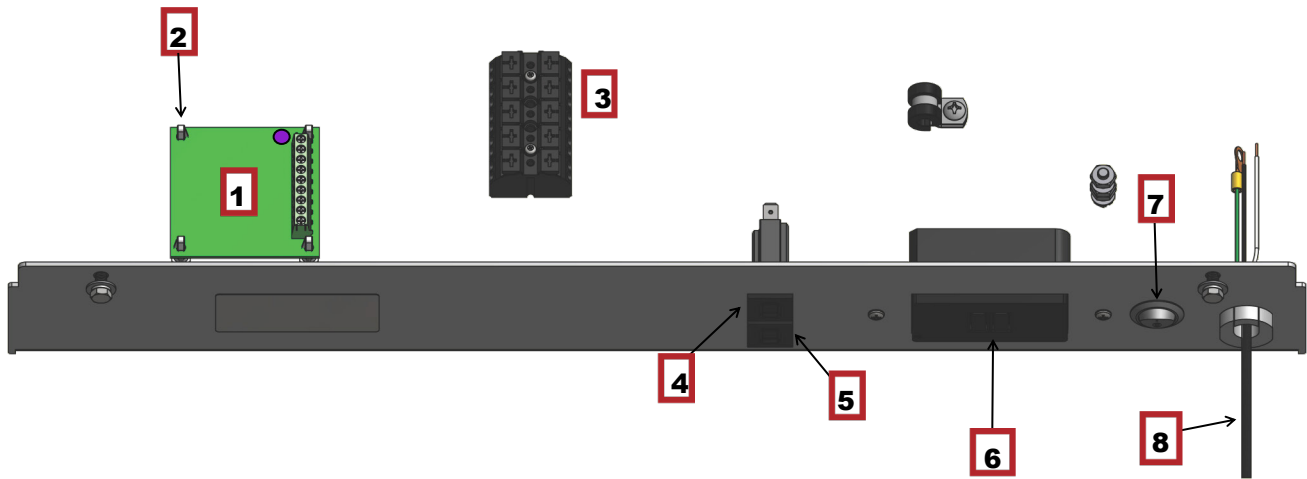

BILL OF MATERIALS FOR ELECTRICAL BOX

ITEM	QTY	PART NUMBER	DESCRIPTION
1	1	1818-037	Programmed Circuit Board for 6" x 15" (Purple Dot)
2	1	6340-070	Circuit Board Mounting Kit Includes: (4) Plastic Clip Stand-Offs
3	1	1875-055	Terminal Block
4	1	1815-030	1A Circuit Breaker
5	1	1815-031	20A Circuit Breaker
6	1	1872-123	GFCI Blank Outlet, 20A/125V
7	1	1872-131	20A Rocker Switch
8	1	6340-097	Power Cord Replacement Kit Includes: (1) Strain Relief, (1) 7' Power Cord