



OPERATING & SERVICE PARTS MANUAL
SM20ES ENERGY SMART® WRAPPER
 Series D



6" x 15" Seal Plate

**Scale pictured is not included*



6" x 15" Seal Plate with
 Optional Label Dispenser and
 Monitor Mount

**Scale pictured is not included*



SM20ES – C6B2WWBPXLD
 6" x 15: Seal Plate with Optional Left &
 Right Wings, Label Dispenser and
 Printer Shelf

**Scale and printer pictured are not included*

READ ALL INSTRUCTIONS CAREFULLY BEFORE OPERATING EQUIPMENT

TABLE OF CONTENTS



Machine Components & Electrical Rating	3
Cradle Mount Film Setup	5
Recommended Maintenance	6
Troubleshooting Guide	7
Control Board Assembly.....	9
Service Parts Information	10

ENERGY SMART® TECHNOLOGY

- The Energy Smart® Wrapper is an innovative system that incorporates an “Instant On” seal plate with the ability to go from ambient to sealing temperature in a matter of seconds. The wrapper uses a photo eye to see when a store associate is wrapping a package and automatically initiates a heat cycle (approximately 3 seconds). After the cycle the wrapper stops heating to conserve energy.
- Heat Seal tests all seal plates before they ship.

HOT ROD HEAT UP

- First, place the desired film in cradle mounts and thread the film up through the machine according to the diagram on the right side of the unit.
- Plug in the power cord and there is a switch on the right side of the electrical box that you may turn on (1).
- Turning on the unit will allow the film cutting rod to begin to heat, it will take a few minutes to get up to optimal cutting temperature (2).
- Caution: The film cutting rod will continue to heat while the wrapper is turned on so contact other than the film for packages should be avoided.

PHOTO EYE ACTUATED HEATER

- The heat cycle in the seal plate begins when a package is placed in front of the photo eye on the seal plate (3).

OPERATOR INDICATOR LIGHT

- A dual-colored LED (4) will change from yellow, when the plate is heating, to red when the plate is at film sealing temperature.

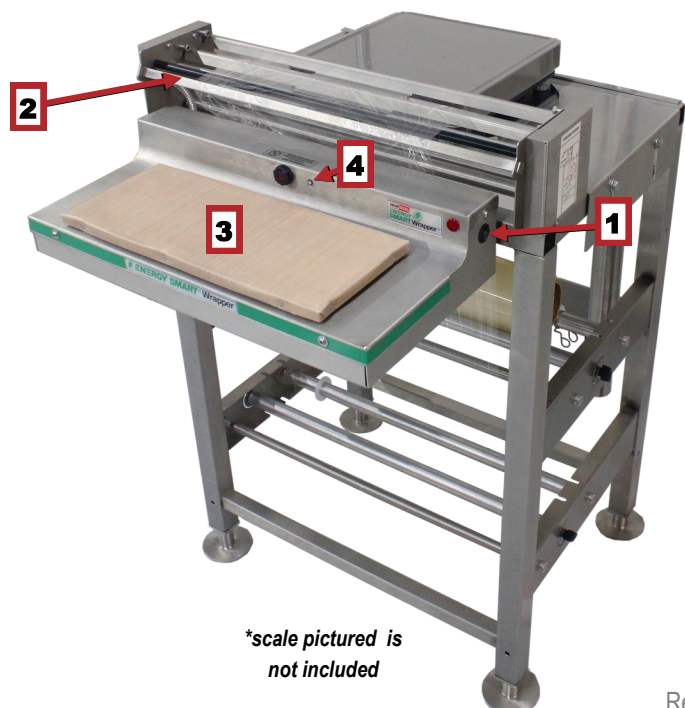

Revised 2021

MOISTURE RESISTANT BARRIER

- In addition to the non-stick cover, the seal plate itself is wrapped in heavy duty Kapton™ Tape in order to protect the seal plate from water and other liquids that it may be exposed to during regular use and cleaning maintenance.

STAINLESS STEEL BRIDGE

- The wrapper comes with a stainless steel bridge that is used to position the scale for weighing and wrapping a package.
- The stainless steel bridge is **not** recommended as a cutting surface.



GFCI

- To maintain circuit protection and integrity, a GFCI is installed in the accessory outlet located midway up on the back left side of the frame. The GFCI may need to be reset if wrapper gets wet or other ground faults arise. Do not reset the GFCI, if visible seal plate damage is present.



TWO ROLL CAPACITY

- The wrapper can hold two 20" rolls of film. The rolls should be mounted and threaded as shown on page 5. There is also a threading diagram on the right side of the unit.

THERMISTOR TEMPERATURE CONTROL

- Due to the rapid response of the seal plate and residual heat that can remain from previous cycles, a thermistor is incorporated as a temperature control device. The heat cycle will be shorter than 3 seconds when residual heat is present in seal plate. The thermistor is located inside the seal plate assembly.

ELECTRICAL RATING

The Model SM20ES is rated 120V 60Hz 132 watts.

CRADLE MOUNT FILM SETUP



FILM THREADING - CRADLE MOUNT

- Film threading is very important to achieve proper film tensioning.
- Route the lower film first.
- Facing the tension knob side of the machine, the film should come off the roll counter-clockwise and go in-between the two rollers it sits on.
- Pull film under the tension roller (3) and film guide roller (1), and up through the film selector rollers.
- The black tension knobs (3) can be adjusted for proper tension on the film by loosening (rotate counter clockwise) or tightening (rotate clockwise) the knob.
- There is a film threading diagram located on the tight side of the unit.

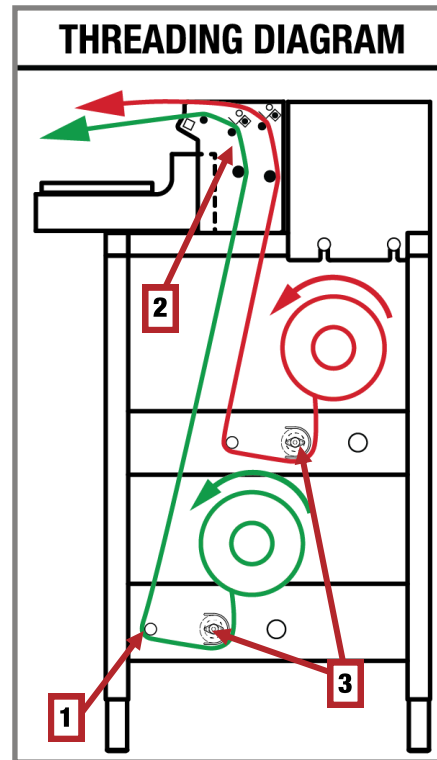

ADJUSTING FOR DIFFERENT WIDTH FILMS

- Squeeze the tensioning devices (4) and slide the white film guides (5) (one on each side of film roll) and secure it near the film roll on both sides. This will help maintain the roll in the center of the machine.

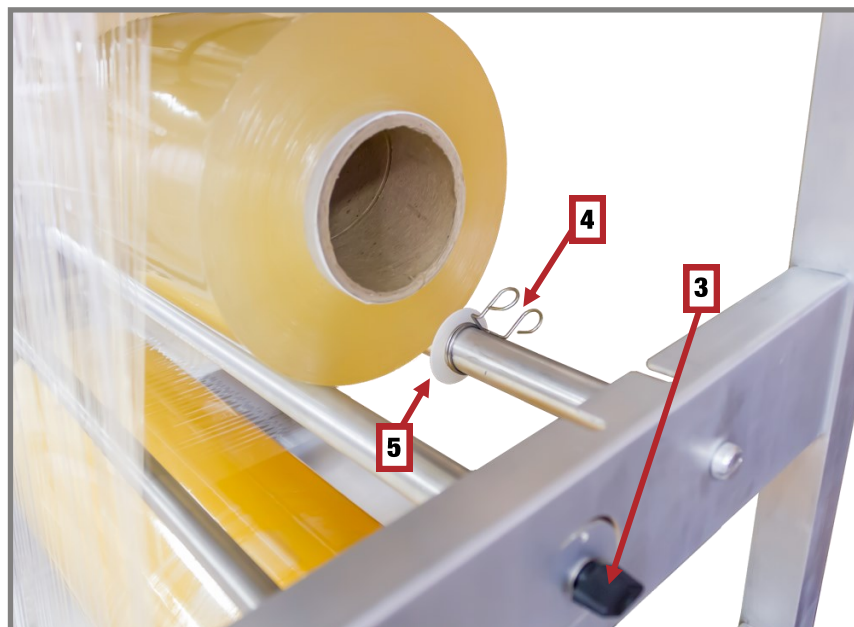



*** MAKE SURE TO TURN OFF THE UNIT, PULL THE PLUG
AND LET THE MACHINE COOL DOWN BEFORE CLEANING ***

NON-STICK COVER & SEAL PLATE

- Due to the advancement of this technology, it is important to keep the non-stick cover in good condition. It is recommended to replace the non-stick cover at least once every (3) months, to protect the seal plate, and maintain a sanitary surface. The seal plate has been designed to provide long life performance when it is properly maintained. **The seal plate should not be used as a cutting surface, any punctures will render the seal plate ineffective and will void the warranty.**
- The non-stick cover is used to create a sanitary, stick free sealing surface. Non-stick covers are porous, so liquid can permeate the cover, and burn off on the hot plate.
- The non-stick cover should be replaced if the surface is soiled or damage is present.
- The seal plate can be cleaned with a mild degreaser. Spray degreaser on a soft cloth or paper towel and wipe the plate while cold. **DO NOT WASH DOWN SEAL PLATE OR SPRAY ANY LIQUIDS DIRECTLY ONTO THE PLATE.**

CLEANING THE CUT OFF ROD

- Make sure that the unit is turned off and the cut off rod is cold to the touch.
- Cover the surface with paper towels to protect it from over spray and debris.
- Spray and coat the cut-off rod generously with an FDA approved "Degreaser".
- After soaking for a few minutes, lightly scrub the surface of the cut-off rod with a scour pad (Scotch-Brite™ type pad).
- Wipe the surface clean of debris and residue with clean paper towels or cloths.
- Repeat degreaser as needed until the rod is clean.

CLEANING THE UNIT

- The SM20ES can be completely wiped down using mild cleaning detergent and a soft cloth or paper towels. **DO NOT HOSE DOWN OR SUBMERGE THE UNIT.**

TROUBLESHOOTING



Symptom	Possible Cause(s)	Solutions
Machine Has No Power	Power Switch Not Turned to 'ON' Position	Turn switch to 'ON' position
	GFI Tripped	Press & hold the reset button for (3) seconds. If GFI does not reset, open the electrical box to identify and fix short/ground fault. If GFI still does not reset, replace the GFI.
	Loose, Missing, or Severed Wire	Check wiring using electrical schematic

Figure 1

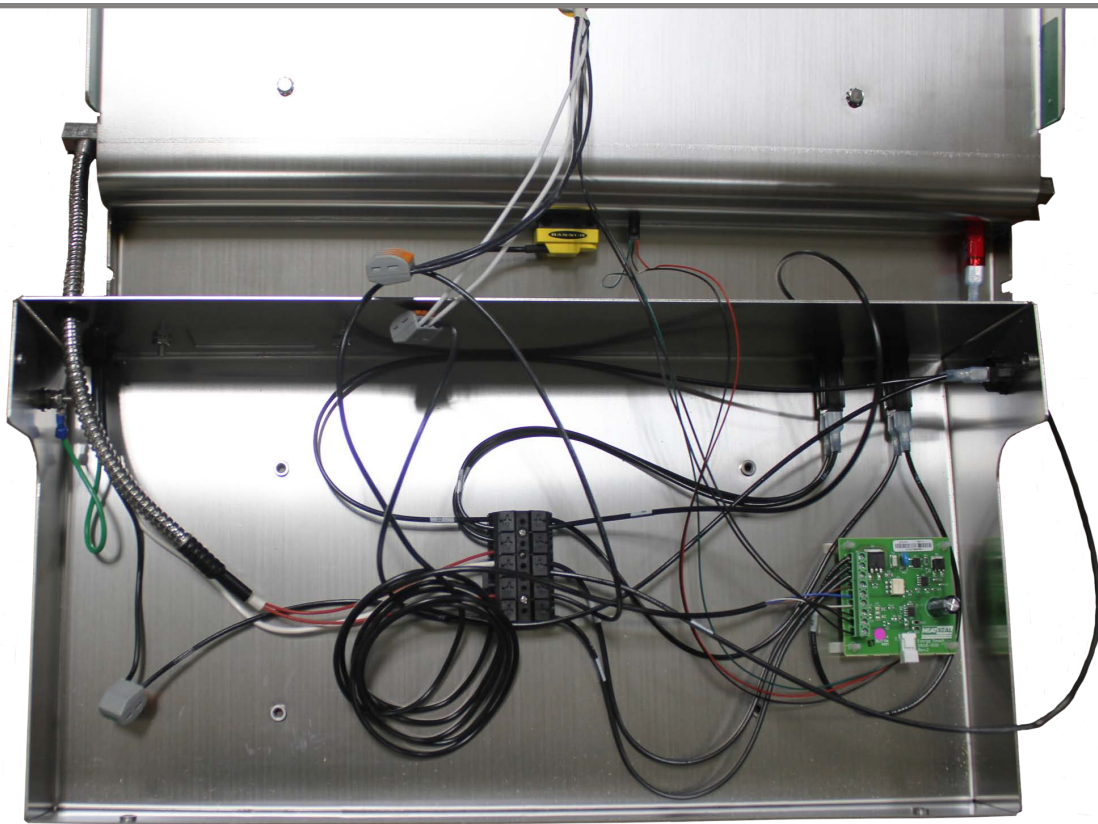

SM20ES Electrical Box Pictured

TROUBLESHOOTING



Symptom	Possible Cause(s)	Solutions
Seal Plate Does Not Heat	Circuit Breaker Tripped/Failure	A tripped circuit breaker will have a white exposed top. Push the circuit breaker tab back in to reset. If breaker cannot be reset, open the electrical box to identify and fix short/ground fault. If breaker still does not reset, replace it.
	Circuit Board Failure	Verify 24VDC between BROWN (+24V) and BLUE (0V) wire on control board. If no voltage is measured, replace circuit board AND photo-eye.
	Photo-eye Failure	Measure DC voltage between BLUE wire (0V) and BLACK wire (PROD_DET) of photo-eye, 24VDC will appear when photo-eye is blocked. The voltage will return to 0V when the photo-eye is unblocked. If not, replace the photo-eye.
	Seal Plate Failure	Check resistance across seal plate element. If heater resistance is not between 6-8Ω, the heater is defective and needs replaced.
	Loose, Missing, or Severed Wire	Check wiring using electrical schematic.
Cutoff Rod Does Not Heat	Circuit Breaker Tripped/Failure	A tripped circuit breaker will have a white exposed top. Push the circuit breaker tab back in to reset. If breaker cannot be reset, open the electrical box to identify and fix short/ground fault. If breaker still does not reset, replace it.
	Cutoff Rod Failure	With power turned off, disconnect both RED wires on the rod. Check resistance across them. A good rod will read between 100-200[Ω] (~400Ω for 700ES-D Mini). A measurement outside this range indicates a bad hot rod that needs replaced.
	Loose, Missing, or Severed Wire	Check wiring using electrical schematic.
Machine Tripping GFI when Photo-eye Activated	Seal plate short/ground fault	Element has internally shorted. Replace seal plate.

CONTROL BOARD ASSEMBLY

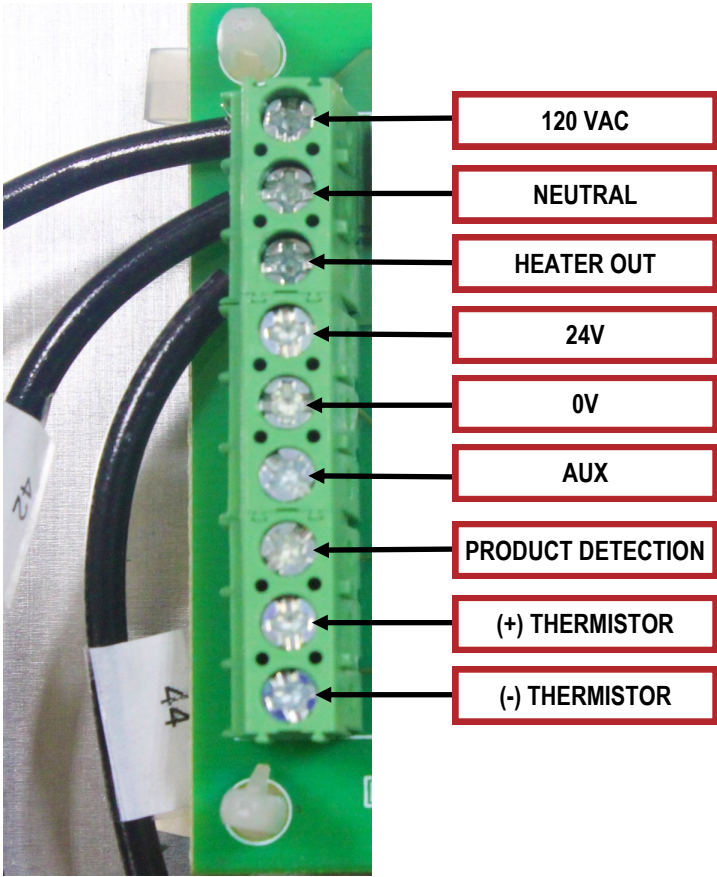

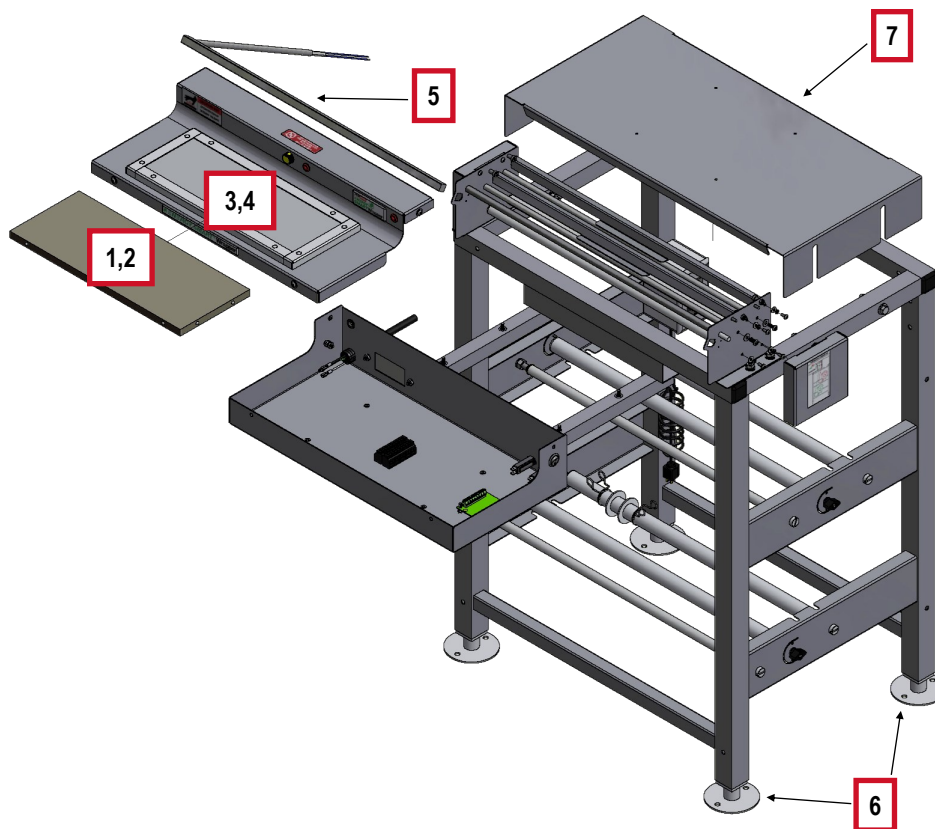

BILL OF MATERIALS FOR MAJOR ASSEMBLIES

ITEM	QTY	PART NUMBER	DESCRIPTION
1	1	5901-011	Non-stick Cover, 6 x 15
2	1	5901-001	Non-stick Cover, 8 x 15
3	1	6137-245	Replacement 6 x 15 Seal Plate Kit
4	1	6137-150	Replacement 8 x 15 Seal Plate Kit (Still Series B 8 x 15)
5	1	6137-094	Hot Rod Replacement Kit Includes : (1) Square Boardless Cut Off Rod with 1 FT Wire Secure and (1) Strain Relief Grommet
6	4	2135-003	Foot, Insert-Flange SS 1 1/2 Sq. Tube
7	1	6137-155	Scale Platform
8	1	1845-113	Grey Duplex GFCI Receptacle
9	1	6137-051	Duplex Outlet Box Enclosure
10	1	1851-051	Power Cord 7' long

SERVICE PARTS INFORMATION

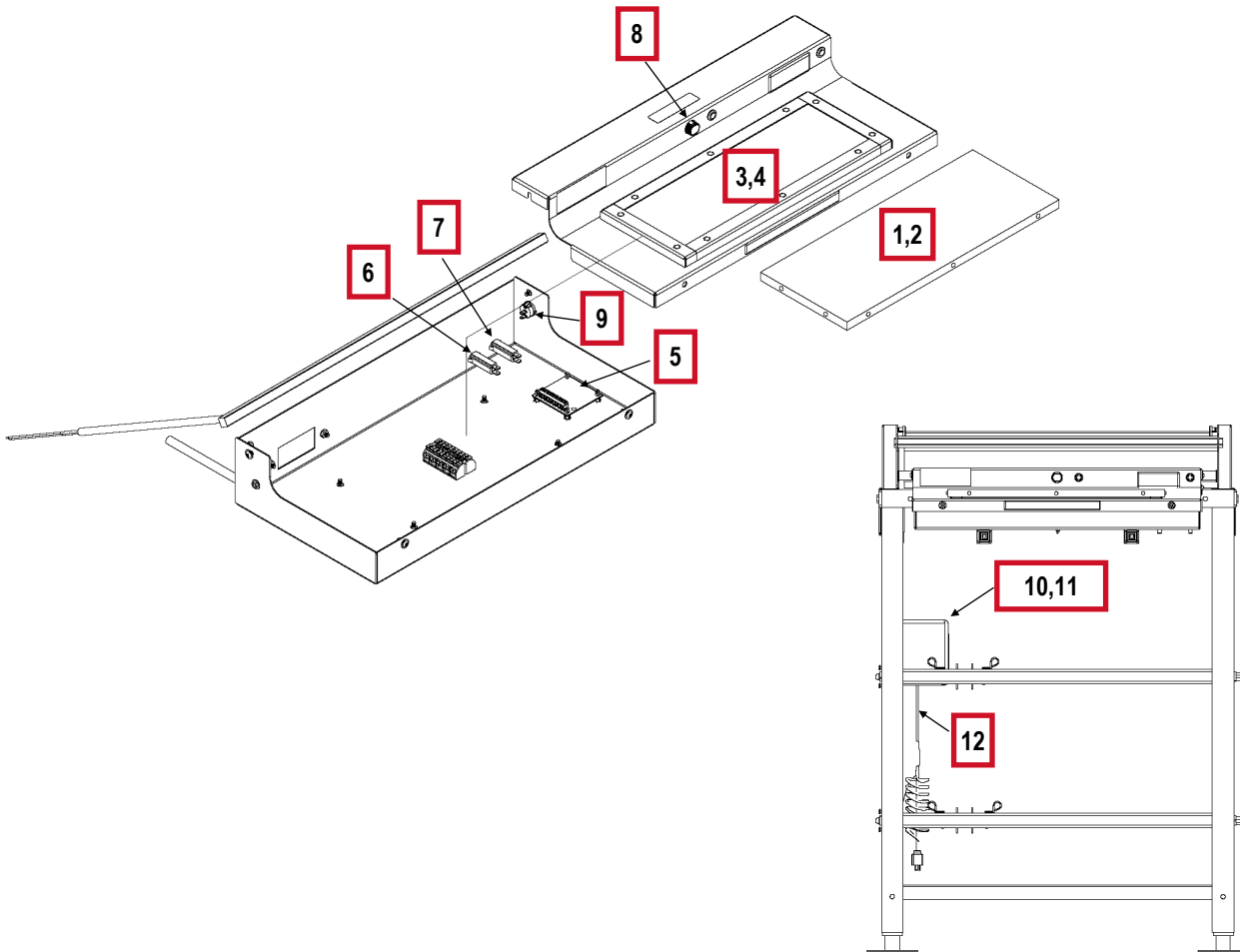

BILL OF MATERIALS FOR ELECTRICAL BOX

ITEM	QTY	PART NUMBER	DESCRIPTION
1	1	5901-011	Non-stick Cover, 6" X 15"
2	1	5901-001	Non-stick Cover, 8" x 15"
3	1	6137-245	Replacement 6 x 15 Seal Plate Kit
4	1	6137-150	Replacement 8 x 15 Seal Plate Kit (Still Series B 8 x 15)
5	1	<u>6 x 15:</u> 1818-037 <u>8 x 15:</u> 1818-036	Energy Smart® Control Board, Programmed
6	1	1815-030	1 Amp Circuit Breaker, Snap-In
7	1	1815-031	20 Amp Circuit Breaker, Snap-In
8	1	1872-133	Photo Eye, Right Angle, Fixed
9	1	1872-131	20A-125V Rocker Switch
10	1	1845-113	Grey Duplex GFCI Receptacle
11	1	6137-051	Duplex Outlet Box Enclosure
12	1	1851-051	Power Cord 7' long

Revised 2021