



Sanitizing Sink Heater

3CS Series

3CS-3

3CS-6

3CS-4

3CS-9

**REPLACEMENT
PARTS LIST**

HATCO 3CS SERIES SANITIZING SINK HEATERS

Model Designation
3CS-X

- 3=Three
- C=Compartment
- S=Sink Heater
- X=Kilowatts

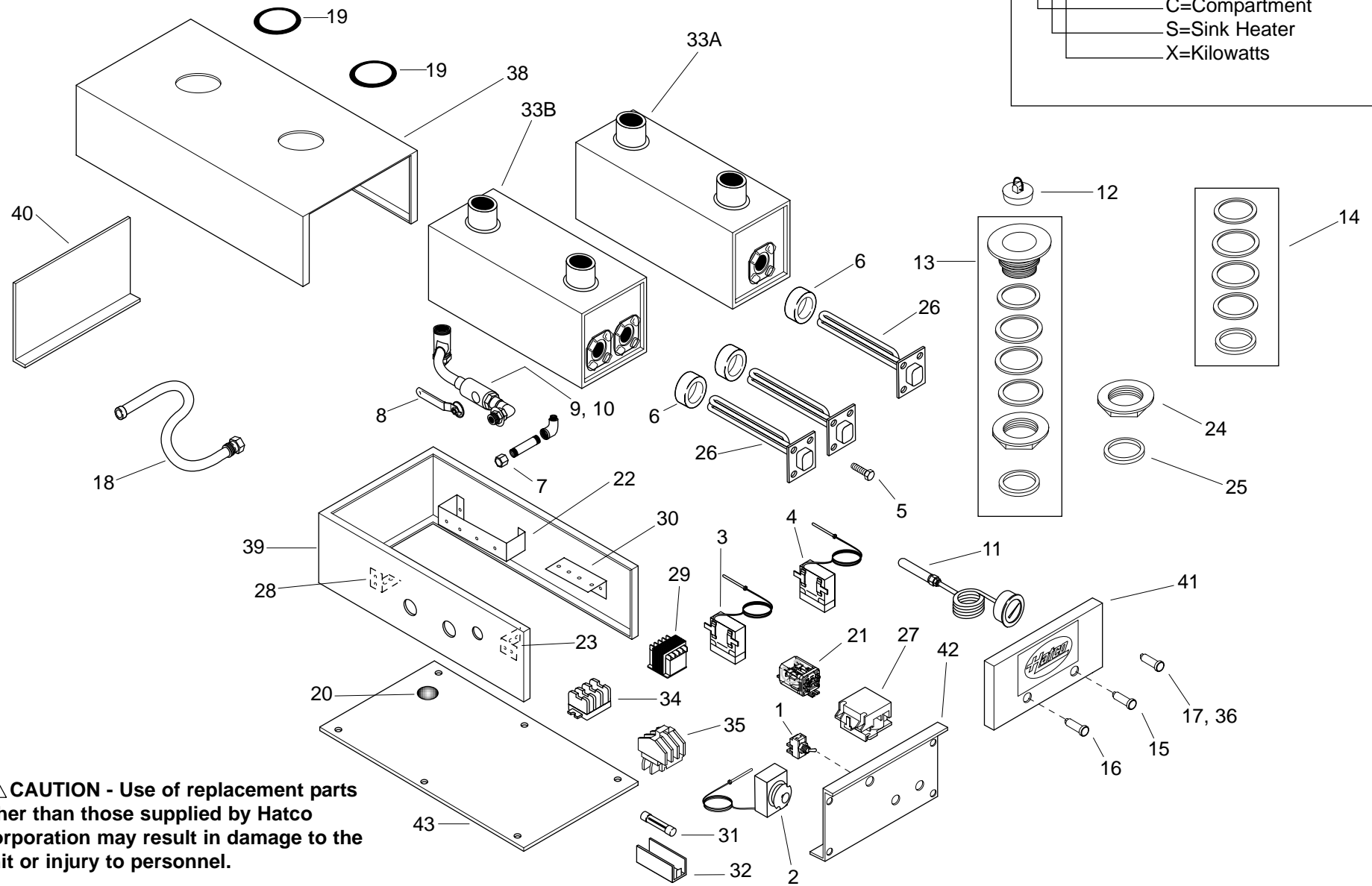

⚠ CAUTION - Use of replacement parts other than those supplied by Hatco Corporation may result in damage to the unit or injury to personnel.

PARTS COMMON TO ALL 3CS MODELS

ITEM	DESCRIPTION	PART NO.	QTY.	ITEM	DESCRIPTION	PART NO.	QTY.
1	On/Off Power Switch	02.19.008A.00	1	12	Stopper, Rubber	05.06.026.00	1
2	Control, Thermostat, 192°F (89°C)	02.16.003A.00	1	13	Sink Strainer Assembly Kit	R05.30.009.00	2
3	Thermostat, Overtemp, 205°F (96°C)	02.16.004.00	1	14	Strainer Gasket Kit	R00.05.0002.00	1
4	Thermostat, At-Temp, 175°F (79°C), (optional)	02.16.004A.00	1	15	Indicator Light, Green	02.19.150.00	1
5	Mounting Bolts	05.04.062.00	4-8	16	Indicator Light, Red	02.19.151.00	1
6	Gasket, Element	05.06.005.00	1-2	17	Indicator Light, Yellow	02.19.152.00	1
7	Drain Cap, Heating Compartment	R03.40.014.00	1	18	Hose with Adaptor	05.06.010.00	1
8	Handle, Sump Drain	03.02.001B.00	1	19	Grommets, Black Molded Rubber	05.06.008.00	2
9	Ball Valve, Sweat Fitting (old style)	03.02.002.00	1	20	Drain Screen Plug, 1" (3 cm)	02.20.026.00	1
10	Ball Valve, Thread Fitting (new style)	03.02.001.00	1	21	Control Relay	R02.01.025.00	1
11	Temperature Monitor (optional)	03.01.005.00	1	22	Mounting Bracket, Thermostat (for #3 & #4)	04.20.003.00	1
				23	Mounting Bracket, Control Thermostat (for #2)	04.20.004.00	1
				24	Brass Locknut	05.30.009A.00	2
				25	Union Gasket	05.06.009.00	2

■ Shaded area in parts lists on the following pages reflects export models only.

Note: S.S. is an abbreviation for stainless steel on the following pages.

PARTS SPECIFIC TO MODEL 3CS-3

ITEM	DESCRIPTION	PARTS SPECIFIC TO MODEL 3CS-3				
		208V 60 Hz	240V 60 Hz	220-230V CE Single Phase 50 Hz	230-240V CE Single Phase 50 Hz	480V 60 Hz
26	Heating Element (Qty. 1)	R02.06.300.00	R02.06.301.00	R02.06.301.00	R02.06.301.00	R02.06.303.00
27	Power Relay	02.01.008.00	02.01.008.00	---	---	---
28	Mounting Bracket, Terminal Block	04.20.001.00	04.20.001.00	---	---	---
29	Transformer	---	---	---	---	R02.17.002.00
30	Mounting Bracket, Transformer	---	---	---	---	04.20.033.00
31	Fuse (AGC-1) (2 Pack)	---	---	---	---	R02.03.001.02
32	Fuse Holder	---	---	---	---	02.03.004.00
33A	Water Tank	R01.04.001.00	R01.04.001.00	R01.04.001.00	R01.04.001.00	R01.04.001.00
33B	Water Tank	---	---	---	---	---
34	Terminal Block	R02.15.003.00	R02.15.003.00	R02.15.035.00	R02.15.035.00	R02.15.003.00
35	Contactors (Qty. 1-2)	---	---	02.01.149.00	02.01.149.00	02.01.016.00
36	Indicator Light, Blue	---	---	02.19.157.00	02.19.157.00	---
37	Rubber Cover, Toggle Switch (Not Shown)	---	---	02.20.040.00	02.20.040.00	---
38	Jacket, Painted	04.06.087.00	04.06.087.00	04.06.087.00	04.06.087.00	04.06.089.00
	Jacket, S.S. (Not Shown)	04.06.088.00	04.06.088.00	04.06.088.00	04.06.088.00	04.06.090.00
39	Base, Painted	04.06.007.00	04.06.007.00	04.06.007.00	04.06.007.00	04.06.113.00
	Base, S.S. (Not Shown)	04.06.009.00	04.06.009.00	04.06.009.00	04.06.009.00	04.06.114.00
40	Rear Plate, Painted	04.06.021.00	04.06.021.00	04.06.021.00	04.06.021.00	04.06.022.00
	Rear Plate, S.S. (Not Shown)	04.06.003A.00	04.06.003A.00	04.06.003A.00	04.06.003A.00	04.06.004A.00
41	Front Cover For Two Indicator Lights	04.06.070.00	04.06.070.00	04.06.070.00	04.06.070.00	04.06.073.00
	Front Cover For One Indicator Light (Not Shown)	04.06.072.00	04.06.072.00	04.06.072.00	04.06.072.00	---
42	Base Front, Painted	04.06.076.00	04.06.076.00	04.06.076.00	04.06.076.00	04.06.081.00
	Base Front, S.S. (Not Shown)	04.06.077.00	04.06.077.00	04.06.077.00	04.06.077.00	04.06.082.00
	Base Front With Monitor Hole, Painted (Not Shown)	04.06.078.00	04.06.078.00	04.06.078.00	04.06.078.00	04.06.083.00
	Base Front With Monitor Hole, S.S. (Not Shown)	04.06.079.00	04.06.079.00	04.06.079.00	04.06.079.00	04.06.084.00
43	Bottom Cover, Painted	04.06.015.00	04.06.015.00	04.06.015.00	04.06.015.00	04.06.016.00
	Bottom Cover, S.S. (Not Shown)	04.06.017.00	04.06.017.00	04.06.017.00	04.06.017.00	04.06.018.00
	Electrical Diagram	HS1-3572	HS1-3572	HS1-4744	HS1-4744	HS1-3573

Shaded area in parts lists on the following pages reflects export models only.

Note: S.S. is an abbreviation for stainless steel on the following pages.

PARTS SPECIFIC TO MODEL 3CS-4

ITEM	DESCRIPTION	Voltage and Phase Specifications				
		208V 60 Hz	240V 60 Hz	220-230V CE Single Phase 50 Hz	230-240V CE Single Phase 50 Hz	480V 60 Hz
26	Heating Element (Qty. 1)	R02.06.450.00	R02.06.451.00	---	---	R02.06.452.00
27	Power Relay	02.01.008.00	02.01.008.00	---	---	---
28	Mounting Bracket, Terminal Block	04.20.001.00	04.20.001.00	---	---	---
29	Transformer	---	---	---	---	R02.17.002.00
30	Mounting Bracket, Transformer	---	---	---	---	04.20.033.00
31	Fuse (AGC-1) (2 Pack)	---	---	---	---	R02.03.001.02
32	Fuse Holder	---	---	---	---	02.03.004.00
33A	Water Tank	R01.04.001.00	R01.04.001.00	---	---	R01.04.001.00
33B	Water Tank	---	---	---	---	---
34	Terminal Block	R02.15.003.00	R02.15.003.00	---	---	R02.15.003.00
35	Contactors (Qty. 1-2)	---	---	---	---	02.01.016.00
36	Indicator Light, Blue	---	---	---	---	---
37	Rubber Cover, Toggle Switch (Not Shown)	---	---	---	---	---
38	Jacket, Painted	04.06.087.00	04.06.087.00	---	---	04.06.089.00
	Jacket, S.S. (Not Shown)	04.06.088.00	04.06.088.00	---	---	04.06.090.00
39	Base, Painted	04.06.007.00	04.06.007.00	---	---	04.06.113.00
	Base, S.S. (Not Shown)	04.06.009.00	04.06.009.00	---	---	04.06.114.00
40	Rear Plate, Painted	04.06.021.00	04.06.021.00	---	---	04.06.022.00
	Rear Plate, S.S. (Not Shown)	04.06.003A.00	04.06.003A.00	---	---	04.06.004A.00
41	Front Cover For Two Indicator Lights	04.06.070.00	04.06.070.00	---	---	04.06.073.00
	Front Cover For One Indicator Light (Not Shown)	04.06.072.00	04.06.072.00	---	---	---
	42	Base Front, Painted	04.06.076.00	04.06.076.00	---	---
42	Base Front, S.S. (Not Shown)	04.06.077.00	04.06.077.00	---	---	04.06.082.00
	Base Front With Monitor Hole, Painted (Not Shown)	04.06.078.00	04.06.078.00	---	---	04.06.083.00
	Base Front With Monitor Hole, S.S. (Not Shown)	04.06.079.00	04.06.079.00	---	---	04.06.084.00
43	Bottom Cover, Painted	04.06.015.00	04.06.015.00	---	---	04.06.016.00
	Bottom Cover, S.S. (Not Shown)	04.06.017.00	04.06.017.00	---	---	04.06.018.00
	Electrical Diagram	HS1-3572	HS1-3572	---	---	HS1-3573

Shaded area in parts lists on the following pages reflects export models only.

Note: S.S. is an abbreviation for stainless steel on the following pages.

PARTS SPECIFIC TO MODEL 3CS-6

ITEM	DESCRIPTION	208V	240V	220-230V CE	230-240V CE	480V
		60 Hz	60 Hz	Single Phase 50 Hz	Single Phase 50 Hz	60 Hz
26	Heating Element (Qty. 2)	R02.06.300.00	R02.06.301.00	R02.06.301.00	R02.06.301.00	R02.06.303.00
27	Power Relay	02.01.008.00	02.01.008.00	---	---	---
28	Mounting Bracket, Terminal Block	04.20.001.00	04.20.001.00	---	---	---
29	Transformer	---	---	---	---	R02.17.002.00
30	Mounting Bracket, Transformer	---	---	---	---	04.20.033.00
31	Fuse (AGC-1) (2 Pack)	---	---	---	---	R02.03.001.02
32	Fuse Holder	---	---	---	---	02.03.004.00
33A	Water Tank	---	---	---	---	---
33B	Water Tank	R01.04.002.00	R01.04.002.00	R01.04.002.00	R01.04.002.00	R01.04.002.00
34	Terminal Block	R02.15.003.00	R02.15.003.00	R02.15.035.00	R02.15.035.00	R02.15.003.00
35	Contactors (Qty. 1-2)	---	---	02.01.149.00	02.01.149.00	02.01.016.00
36	Indicator Light, Blue	---	---	02.19.157.00	02.19.157.00	---
37	Rubber Cover, Toggle Switch (Not Shown)	---	---	02.20.040.00	02.20.040.00	---
38	Jacket, Painted	04.06.087.00	04.06.087.00	04.06.087.00	04.06.087.00	04.06.089.00
	Jacket, S.S. (Not Shown)	04.06.088.00	04.06.088.00	04.06.088.00	04.06.088.00	04.06.090.00
39	Base, Painted	04.06.007.00	04.06.007.00	04.06.007.00	04.06.007.00	04.06.113.00
	Base, S.S. (Not Shown)	04.06.009.00	04.06.009.00	04.06.009.00	04.06.009.00	04.06.114.00
40	Rear Plate, Painted	04.06.021.00	04.06.021.00	04.06.021.00	04.06.021.00	04.06.022.00
	Rear Plate, S.S. (Not Shown)	04.06.003A.00	04.06.003A.00	04.06.003A.00	04.06.003A.00	04.06.004A.00
41	Front Cover For Two Indicator Lights	04.06.070.00	04.06.070.00	04.06.070.00	04.06.070.00	04.06.073.00
	Front Cover For One Indicator Light (Not Shown)	04.06.072.00	04.06.072.00	04.06.072.00	04.06.072.00	---
42	Base Front, Painted	04.06.076.00	04.06.076.00	04.06.076.00	04.06.076.00	04.06.081.00
	Base Front, S.S. (Not Shown)	04.06.077.00	04.06.077.00	04.06.077.00	04.06.077.00	04.06.082.00
	Base Front With Monitor Hole, Painted (Not Shown)	04.06.078.00	04.06.078.00	04.06.078.00	04.06.078.00	04.06.083.00
	Base Front With Monitor Hole, S.S. (Not Shown)	04.06.079.00	04.06.079.00	04.06.079.00	04.06.079.00	04.06.084.00
43	Bottom Cover, Painted	04.06.015.00	04.06.015.00	04.06.015.00	04.06.015.00	04.06.016.00
	Bottom Cover, S.S. (Not Shown)	04.06.017.00	04.06.017.00	04.06.017.00	04.06.017.00	04.06.018.00
	Electrical Diagram	HS1-3570	HS1-3570	HS1-4741	HS1-4741	HC1-580

Shaded area in parts lists on the following pages reflects export models only.

Note: S.S. is an abbreviation for stainless steel on the following pages.

PARTS SPECIFIC TO MODEL 3CS-9

ITEM	DESCRIPTION	208V	240V	220-230V CE	230-240V CE	480V
		60 Hz	60 Hz	Single Phase 50 Hz	Single Phase 50 Hz	60 Hz
26	Heating Element (Qty. 2)	R02.06.450.00	R02.06.451.00	---	---	R02.06.452.00
27	Power Relay	02.01.008.00	02.01.008.00	---	---	---
28	Mounting Bracket, Terminal Block	04.20.001.00	04.20.001.00	---	---	---
29	Transformer	---	---	---	---	R02.17.002.00
30	Mounting Bracket, Transformer	---	---	---	---	04.20.033.00
31	Fuse (AGC-1) (2 Pack)	---	---	---	---	R02.03.001.02
32	Fuse Holder	---	---	---	---	02.03.004.00
33A	Water Tank	---	---	---	---	---
33B	Water Tank	R01.04.002.00	R01.04.002.00	---	---	R01.04.002.00
34	Terminal Block	R02.15.003.00	R02.15.003.00	---	---	R02.15.003.00
35	Contactors (Qty. 1-2)	---	---	---	---	02.01.016.00
36	Indicator Light, Blue	---	---	---	---	---
37	Rubber Cover, Toggle Switch (Not Shown)	---	---	---	---	---
38	Jacket, Painted	04.06.087.00	04.06.087.00	---	---	04.06.089.00
	Jacket, S.S. (Not Shown)	04.06.088.00	04.06.088.00	---	---	04.06.090.00
39	Base, Painted	04.06.007.00	04.06.007.00	---	---	04.06.113.00
	Base, S.S. (Not Shown)	04.06.009.00	04.06.009.00	---	---	04.06.114.00
40	Rear Plate, Painted	04.06.021.00	04.06.021.00	---	---	04.06.022.00
	Rear Plate, S.S. (Not Shown)	04.06.003A.00	04.06.003A.00	---	---	04.06.004A.00
41	Front Cover For Two Indicator Lights	04.06.070.00	04.06.070.00	---	---	04.06.073.00
	Front Cover For One Indicator Light (Not Shown)	04.06.072.00	04.06.072.00	---	---	---
	42	Base Front, Painted	04.06.076.00	04.06.076.00	---	---
42	Base Front, S.S. (Not Shown)	04.06.077.00	04.06.077.00	---	---	04.06.082.00
	Base Front With Monitor Hole, Painted (Not Shown)	04.06.078.00	04.06.078.00	---	---	04.06.083.00
	Base Front With Monitor Hole, S.S. (Not Shown)	04.06.079.00	04.06.079.00	---	---	04.06.084.00
	43	Bottom Cover, Painted	04.06.015.00	04.06.015.00	---	---
43	Bottom Cover, S.S. (Not Shown)	04.06.017.00	04.06.017.00	---	---	04.06.018.00
	Electrical Diagram	HS1-3570	HS1-3570	---	---	HC1-580

Shaded area in parts lists on the following pages reflects export models only.

Note: S.S. is an abbreviation for stainless steel on the following pages.

HATCO AUTHORIZED PARTS DISTRIBUTORS

ALABAMA

Jones McLeod Appl. Svc.
Birmingham 205-251-0159

ARIZONA

Auth. Comm. Food Equip.
Phoenix 602-234-2443
Byassee Equipment Co.
Phoenix 602-252-0402

CALIFORNIA

Industrial Electric
Huntington Beach 714-379-7100
Chapman Appl. Service
San Diego 619-298-7106
P & D Appliance
S. San Francisco 650-635-1900

COLORADO

All City Service
Denver 303-454-9500
Hawkins Commercial Appliance
Englewood 303-781-5548

DELAWARE

Food Equipment Service
Wilmington 302-996-9363

FLORIDA

Whaley Foodservice Repair
Jacksonville 904-725-7800
Nass Service Co., Inc.
Orlando 407-425-2681
B.G.S.I.
Pompano Beach 954-971-0456
Comm. Appliance Service
Tampa 813-663-0313

GEORGIA

Southeastern Rest. Svc.
Norcross 770-446-6177

HAWAII

Burney's Comm. Service, Inc.
Honolulu 808-848-1466
Food Equip Parts & Service
Honolulu 808-847-4871

ILLINOIS

Parts Town
Broadview 708-865-7278
Eichenauer Elec. Service
Decatur 217-429-4229
Midwest Elec. Appl. Service
Elmhurst 630-279-8000
Cone's Repair Service
Moline 309-797-5323

INDIANA

Comm. Parts & Service, Inc.
Indianapolis 317-545-9655

IOWA

Electric Motor Service Co.
Davenport 319-323-1823

KENTUCKY

Comm. Parts & Service, Inc.
Louisville 502-367-1788

LOUISIANA

Chandlers Parts & Service
Baton Rouge 225-272-6620

LOUISIANA (Continued)

Bana Comm. Parts, Inc.
Shreveport 318-631-6550

MARYLAND

Electric Motor Service
Baltimore 410-467-8080
GCS Service, Inc.
Silver Spring 301-585-7550

MASSACHUSETTS

Ace Service Co., Inc.
Needham 781-449-4220

MICHIGAN

Commercial Kitchen Service
Bay City 517-893-4561
Bildons Appliance Service
Detroit 248-478-3320
Midwest Food Equip. Service
Grandville 616-261-2000

MINNESOTA

GCS Service
Minneapolis 612-546-4221

MISSOURI

GCS Service, Inc.
Kansas City 816-920-5999
Commercial Kitchen Services
St. Louis 314-890-0700
Kaemmerlen Parts & Service
St. Louis 314-535-2222

NEBRASKA

Anderson Electric
Omaha 402-341-1414

NEVADA

Burney's Commercial
Las Vegas 702-736-0006

NEW JERSEY

Jay Hill Repair
Fairfield 973-575-9145
Service Plus
Flanders 973-691-6300

NEW YORK

Acme American Repairs, Inc.
Brooklyn 718-456-6544
Alpro Service Co.
Brooklyn 718-386-2515
Appliance Installation
Buffalo 716-884-7425
Northern Parts Dist.
Plattsburgh 518-563-3200
J. B. Brady, Inc.
Syracuse 315-422-9271

NORTH CAROLINA

Authorized Appliance
Charlotte 704-377-4501

OHIO

Akron/Canton Comm. Svc. Inc.
Akron 330-753-6635
Certified Service Center
Cincinnati 513-772-6600
GCS Service
Columbus 614-476-3225
Electrical Appl. Repair Service
Independence 216-459-8700

OHIO (Continued)

E. A. Wichman Co.
Toledo 419-385-9121

OKLAHOMA

Hagar Rest. Service, Inc.
Oklahoma City 405-235-2184
Krueger, Inc.
Oklahoma City 405-528-8883

OREGON

Bressie Electric Co.
Portland 503-231-7171
Ron's Service, Inc.
Portland 503-624-0890

PENNSYLVANIA

Authorized Factory Service
Coraopolis 412-262-2330
FAST Comm. Appl. Service
Philadelphia 215-288-4800
GCS Service, Inc.
Pittsburgh 412-787-1970
K & D Service Co.
Harrisburg 717-236-9039
Elmer Schultz Services
Philadelphia 215-627-5401
Electric Repair Co.
Reading 610-376-5444

RHODE ISLAND

Marshall Electric Co.
Providence 401-331-1163

SOUTH CAROLINA

Whaley Foodservice Repair
W. Columbia 803-791-4420

TENNESSEE

Camp Electric
Memphis 901-527-7543

TEXAS

City Kitchen Service Co.
Austin 512-719-4445
Stove Parts Supply
Fort Worth 817-831-0381
Armstrong Repair Service
Houston 713-666-7100
Commercial Kitchen Repair Co.
San Antonio 210-735-2811
San Antonio Rest. Equip.
San Antonio 210-824-3271

UTAH

Peterson's Commercial Parts & Svc.
Salt Lake City 801-487-3653

VIRGINIA

Daubers
Norfolk 757-855-4097
Daubers
Springfield 703-866-3600

WASHINGTON

Restaurant Appl. Service
Seattle 206-524-8200

WISCONSIN

A.S.C., Inc.
Madison 608-246-3160
A.S.C., Inc.
Milwaukee 414-543-6460

HATCO CORPORATION

P.O. Box 340500, Milwaukee, WI 53234-0500 U.S.A.

(800) 558-0607 (414) 671-6350

Parts & Service Fax (800) 690-2966 Int'l. Fax (414) 671-3976

Web Site: www.hatcocorp.com