

hatcocorp.com

Register Online!  
(see page 2)



# Atmospheric Hot Water Dispenser AWD Series

## Installation and Operating Manual

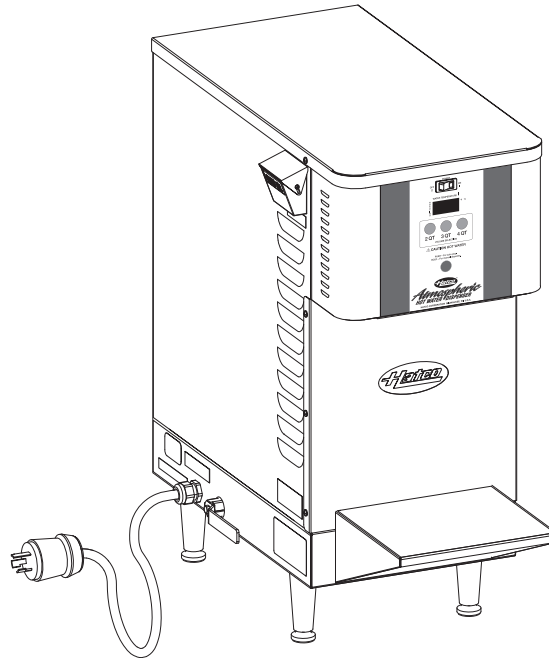

### **⚠ WARNING**

Do not operate this equipment unless you have read and understood the contents of this manual! Failure to follow the instructions contained in this manual may result in serious injury or death. This manual contains important safety information concerning the maintenance, use, and operation of this product. If you're unable to understand the contents of this manual, please bring it to the attention of your supervisor. Keep this manual in a safe location for future reference.

### **⚠ ADVERTENCIA**

No opere este equipo al menos que haya leído y comprendido el contenido de este manual! Cualquier falla en el seguimiento de las instrucciones contenidas en este manual puede resultar en un serio lesión o muerte. Este manual contiene importante información sobre seguridad concerniente al mantenimiento, uso y operación de este producto. Si usted no puede entender el contenido de este manual por favor pregunte a su supervisor. Almacenar este manual en una localización segura para la referencia futura.

### **⚠ AVERTISSEMENT**

Ne pas utiliser cet équipement sans avoir lu et compris le contenu de ce manuel ! Le non-respect des instructions contenues dans ce manuel peut entraîner de graves blessures ou la mort. Ce manuel contient des informations importantes concernant l'entretien, l'utilisation et le fonctionnement de ce produit. Si vous ne comprenez pas le contenu de ce manuel, veuillez le signaler à votre supérieur. Conservez ce manuel dans un endroit sûr pour pouvoir vous y référer plus tard.

# CONTENTS

<b>Important Owner Information</b> .....	<b>2</b>	<b>Maintenance</b> .....	<b>9</b>
<b>Introduction</b> .....	<b>2</b>	General .....	9
<b>Important Safety Information</b> .....	<b>3</b>	Daily Cleaning.....	9
<b>Model Description</b> .....	<b>4</b>	Draining the Dispenser .....	9
<b>Model Designation</b> .....	<b>4</b>	De-Liming the Dispenser .....	10
<b>Specifications</b> .....	<b>4</b>	Resetting the High Temperature Safety Switch .....	11
Plug Configurations .....	4	<b>Troubleshooting Guide</b> .....	<b>12</b>
Electrical Rating Chart.....	4	Error Codes .....	12
Dimensions .....	5	<b>Options and Accessories</b> .....	<b>13</b>
<b>Installation</b> .....	<b>6</b>	<b>Limited Warranty</b> .....	<b>15</b>
General .....	6	<b>Authorized Parts Distributors</b> .....	<b>Back Cover</b>
<b>Operation</b> .....	<b>7</b>		
General .....	7		
Dispensing Hot Water .....	7		
Programming the Dispenser .....	8		

## IMPORTANT OWNER INFORMATION

Record the model number, serial number (specification label located on the lower side of the unit), voltage, and purchase date of the unit in the spaces below. Please have this information available when calling Hatco for service assistance.

Model No. \_\_\_\_\_

Serial No. \_\_\_\_\_

Voltage \_\_\_\_\_

Date of Purchase \_\_\_\_\_

### Register your unit!

Completing online warranty registration will prevent delay in obtaining warranty coverage. Access the Hatco website at [www.hatcocorp.com](http://www.hatcocorp.com), select the *Parts & Service* pull-down menu, and click on "Warranty Registration".

### Business

Hours: 7:00 AM to 5:00 PM Central Standard Time (CST)  
 (Summer Hours: June to September—  
 7:00 AM to 5:00 PM CST Monday–Thursday  
 7:00 AM to 4:00 PM CST Friday)

Telephone: 800-558-0607; 414-671-6350

e-mail: [partsandservice@hatcocorp.com](mailto:partsandservice@hatcocorp.com)



24 Hour 7 Day Parts and Service Assistance available in the United States and Canada by calling 800-558-0607.

Additional information can be found by visiting our web site at [www.hatcocorp.com](http://www.hatcocorp.com).

## INTRODUCTION

Hatco Atmospheric Hot Water Dispensers quickly provide 2, 3, or 4 quarts (1.9, 2.8, or 3.8 liters) of hot water for food preparation or cleaning. A 12 gallon (45 liter) stainless steel tank provides up to 8 gallons (30 liters) of continuous hot water. The setpoint temperature can be adjusted from 75–195°F (24–91°C), with the factory default setting at 195°F (91°C). The tank can be emptied using the convenient bottom drain.

Hatco Atmospheric Hot Water Dispensers design features include an electronic temperature controller with a digital temperature display, POWER ON/OFF (I/O) switch, premeasure dispense buttons, and a manual dispense button for additional water volume options.

Standard equipment includes a stainless steel base, a powder coated body, 4" (102 mm) legs and a 6' (1829 mm) electrical cord and plug. All electric heating elements are metal sheathed and controlled by a submersed thermistor. The units are protected with a high-temperature limit switch and low-water cutoff.

The unit electrical and plumbing connections are factory-assembled and ready for installation.

This manual provides the installation, safety, and operating instructions for Atmospheric Hot Water Dispensers. Hatco recommends all installation, operating, and safety instructions appearing in this manual be read prior to installation or operation of a unit.

Safety information that appears in this manual is identified by the following signal word panels:



**WARNING** indicates a hazardous situation which, if not avoided, could result in death or serious injury.



**CAUTION** indicates a hazardous situation which, if not avoided, could result in minor or moderate injury.



**NOTICE** is used to address practices not related to personal injury.

# IMPORTANT SAFETY INFORMATION



Read the following important safety information before using this equipment to avoid serious injury or death and to avoid damage to equipment or property.

## WARNING

### ELECTRIC SHOCK HAZARD:

- Plug unit into a properly grounded electrical receptacle of the correct voltage, size, and plug configuration. If plug and receptacle do not match, contact a qualified electrician to determine and install the proper voltage and size electrical receptacle.
- Unit must be installed by qualified, trained installers. Installation must conform to all local electrical and plumbing codes. Installation by unqualified personnel will void the unit warranty and may lead to electric shock or burn, as well as damage to unit and/or its surroundings. Check with local plumbing and electrical inspectors for proper procedures and codes.
- Turn OFF power switch, unplug power cord, and allow unit to cool before performing any cleaning, adjustments, or maintenance.
- DO NOT submerge or saturate with water. Unit is not waterproof. Do not operate if unit has been submerged or saturated with water.
- Unit is not weatherproof. Locate unit indoors where ambient air temperature is a minimum of 70°F (21°C).
- Do not steam clean or use excessive water on unit.
- This unit is not “jet-proof” construction. Do not use jet-clean spray to clean this unit.
- Do not pull unit by power cord.
- Discontinue use if power cord is frayed or worn.
- Do not attempt to repair or replace a damaged power cord. The cord must be replaced by Hatco, an Authorized Hatco Service Agent, or a person with similar qualifications.
- This unit must be serviced by qualified personnel only. Service by unqualified personnel may lead to electric shock or burn.
- Use only Genuine Hatco Replacement Parts when service is required. Failure to use Genuine Hatco Replacement Parts will void all warranties and may subject operators of the equipment to hazardous electrical voltage, resulting in electrical shock or burn. Genuine Hatco Replacement Parts are specified to operate safely in the environments in which they are used. Some aftermarket or generic replacement parts do not have the characteristics that will allow them to operate safely in Hatco equipment.

**EXPLOSION HAZARD:** Do not store or use gasoline or other flammable vapors or liquids in the vicinity of this or any other appliance.

This unit has no “user-serviceable” parts. If service is required on this unit, contact an Authorized Hatco Service Agent or contact the Hatco Service Department at 800-558-0607 or 414-671-6350.

## WARNING

Make sure all operators have been instructed on the safe and proper use of the unit.

This unit is not intended for use by children or persons with reduced physical, sensory, or mental capabilities. Ensure proper supervision of children and keep them away from the unit.

## CAUTION

### BURN HAZARD:

- Some exterior surfaces on unit will get hot. Use caution when touching these areas.
- Drain water may reach temperatures in excess of 200°F (93°C). Use appropriate plumbing materials when installing drain.

Auto-Fill units must be installed with adequate backflow protection and must conform with all federal, state, and local codes.

All water and waste piping and connections shall comply with the International Plumbing Code 2003, International Code Council (ICC), or to the Uniform Plumbing Code 2003, International Association of Plumbing and Mechanical Officials (IAPMO).

Locate unit at the proper counter height in an area that is convenient for use. The location should be level to prevent the unit or its contents from falling accidentally and strong enough to support the weight of the unit and contents.

## NOTICE

Damage to any countertop material caused by heat generated from Hatco equipment is not covered under the Hatco warranty. Contact the manufacturer of the countertop material for application information.

Do not use deionized water. Deionized water will shorten the life of water reservoir and heating element.

Transport unit in upright position. If laid on its side, water must be drained from unit.

Do not over-tighten plumbing connections. Overtightening may cause leaks.

Incoming water in excess of 3.0 grains of hardness per gallon (GPG) (0.75 grains of hardness per liter) must be treated and softened before being supplied to an Atmospheric Hot Water Dispenser. Water containing over 3.0 GPG (0.75 GPL) will decrease the efficiency and reduce the operating life of the unit.

Incoming water supply must not exceed 140°F (60°C). Water pressure must be at least 35 psi (241 kPa) and not exceed 80 psi (552 kPa).

Use non-abrasive cleaners and cloths only. Abrasive cleaners and cloths could scratch finish of unit, marring its appearance and making it susceptible to soil accumulation.

Clean unit daily to avoid malfunctions and maintain sanitary operation.

# MODEL DESCRIPTION

## All Models

Hatco Atmospheric Hot Water Dispensers are equipped with an electronic temperature controller, a digital temperature display, a POWER ON/OFF (I/O) switch, pre-measured dispensing buttons, and a manual dispense button. The units are protected with a high-temperature limit switch and low-water cut-off.

Atmospheric Hot Water Dispensers deliver premeasure 2, 3, or 4 quart (1.9, 2.8, 3.8 liter) quantities of hot water at temperatures up to 195°F (91°C). This compact and durable unit requires minimal counter space and a removable shelf allows access to dispense water into large containers.

Standard equipment includes a stainless steel base, a powder coated body, 4" (102 mm) legs, tank drain valve, and a 6' (1829 mm) electrical cord and plug.

A 12 gallon (45 liter) stainless steel tank provides up to 8 gallons (30 liters) of continuous, temperature-controlled water ranging from 75–195°F (24–91°C). The tank is drained easily with a convenient bottom drain fitting.

*NOTE: Refer to the OPTIONS AND ACCESSORIES section for alternate dispensing volumes, wall mounting, and other available options and accessories.*

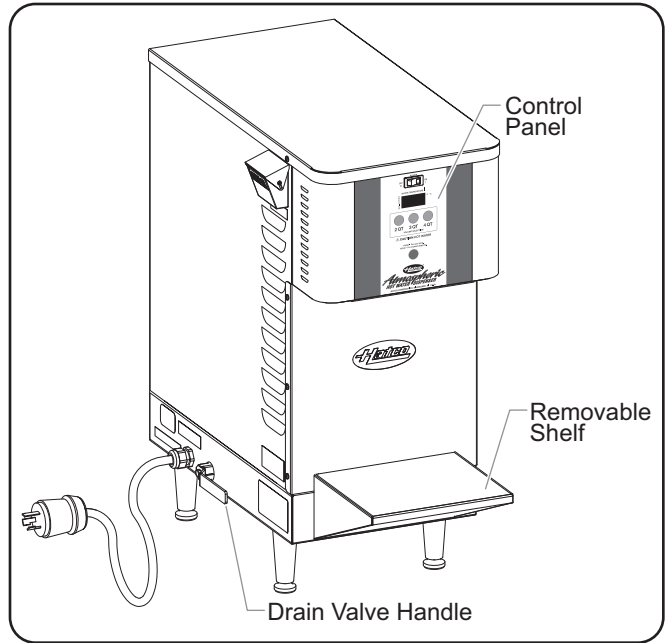

Model AWD-12

# MODEL DESIGNATION

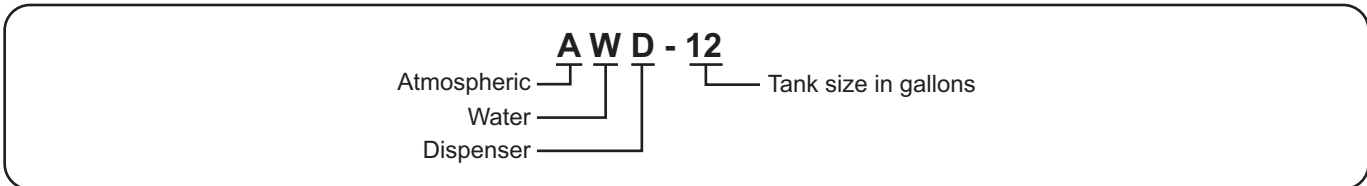

# SPECIFICATIONS

## Plug Configurations

Units are supplied from the factory with an electrical cord and plug installed. Plugs are supplied according to the applications.



**ELECTRIC SHOCK HAZARD:** Plug unit into a properly grounded electrical receptacle of the correct voltage, size, and plug configuration. If plug and receptacle do not match, contact a qualified electrician to determine and install the proper voltage and size electrical receptacle.

*NOTE: Specification label located on the lower side of the unit. See label for serial number and verification of unit electrical information.*

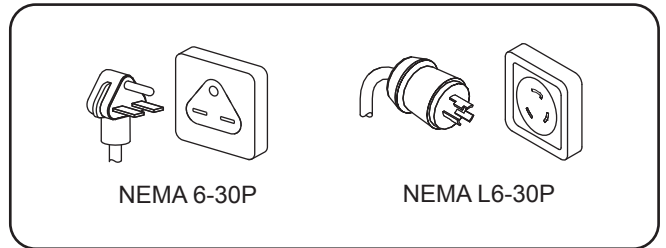

Plug Configurations

*NOTE: Receptacle not supplied by Hatco.*

## Electrical Rating Chart

Model	Voltage	Kilowatts	Amps	Plug Configuration	Shipping Weight†
AWD-12	208	5	24.0	NEMA 6-30P*	80 lbs. (36 kg)
	240	5	20.8	NEMA 6-30P*	80 lbs. (36 kg)

\* NEMA L6-30P is optional.

† Unit weight filled with water capacity (12 gallons [45 liters]) is 180 lbs. (82 kg).

# SPECIFICATIONS

## Dimensions

Model	Width (A)	Depth (B)	Height (C)	Footprint Width (D)	Footprint Depth (E)
AWD-12	13-3/8" (339 mm)	27-1/2" (698 mm)	28-1/16" (713 mm)	10-3/4" (273 mm)	14-3/4" (375 mm)

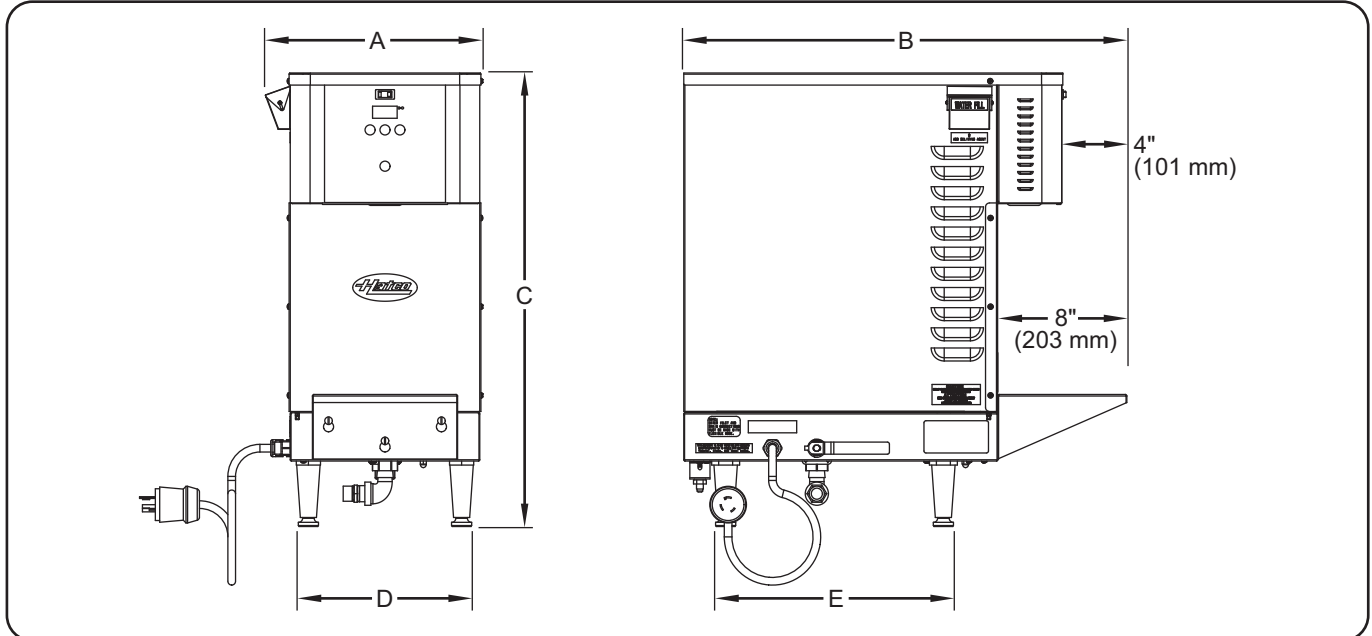

## Water Temperature Recovery Table

Model	kW	Degrees of Rise										
		60°F (33°C)	70°F (39°C)	80°F (44°C)	90°F (50°C)	100°F (55°C)	110°F (61°C)	120°F (66°C)	130°F (72°C)	140°F (78°C)	150°F (83°C)	160°F (88°C)
AWD-12	5	33 gph (125 lph)	29 gph (110 lph)	25 gph (95 lph)	22 gph (83 lph)	20 gph (75 lph)	18 gph (68 lph)	17 gph (64 lph)	15 gph (57 lph)	14 gph (53 lph)	13 gph (49 lph)	12 gph (45 lph)

NOTE: gph is gallons per hour; lph is liters per hour.

## Cold-Start Heat-Up Time

Model	kW	Degrees of Rise		
		60°F (33°C)	90°F (50°C)	140°F (78°C)
AWD-12	5	22 Minutes	33 Minutes	52 Minutes

## Water Temperature Recovery Time

Model	kW	Degrees of Rise		
		60°F (33°C)	90°F (50°C)	140°F (78°C)
AWD-12	5	15 Minutes*	22 Minutes*	35 Minutes*

\* Recovery times are after 10 gallons (37 liters) of water have been dispensed.

# INSTALLATION

## General

Use the following information and procedures to install a Atmospheric Hot Water Dispensers.

### **WARNING**

#### ELECTRIC SHOCK HAZARD:

- Plug unit into a properly grounded electrical receptacle of the correct voltage, size, and plug configuration. If plug and receptacle do not match, contact a qualified electrician to determine and install the proper voltage and size electrical receptacle.
- Unit is not weatherproof. Locate unit indoors where ambient air temperature is a minimum of 70°F (21°C).

### **CAUTION**

Auto-Fill units must be installed with adequate backflow protection and must conform with all federal, state, and local codes.

All water and waste piping and connections shall comply with the International Plumbing Code 2003, International Code Council (ICC), or to the Uniform Plumbing Code 2003, International Association of Plumbing and Mechanical Officials (IAPMO).

Locate unit at the proper counter height in an area that is convenient for use. The location should be level to prevent the unit or its contents from falling accidentally and strong enough to support the weight of the unit and contents.

1. Remove the unit from the carton.
2. Remove tape and protective packaging from all surfaces of unit.

*NOTE: To prevent delay in obtaining warranty coverage, complete online warranty registration. See the IMPORTANT OWNER INFORMATION section for details.*

3. Place the unit in the desired location. Refer to the OPTIONS AND ACCESSORIES section for wall mount installation.
  - Locate the unit in an area where the ambient air temperature is constant and a minimum of 70°F (21°C). Avoid areas that may be subject to active air movements or currents (i.e., near exterior doors, exhaust fans/hoods, air conditioning ducts, etc...).
  - Make sure the unit is at the proper counter height in an area convenient for use.
  - Make sure the countertop is level and strong enough to support the weight of the unit and the water inside.

*NOTE: Unit weight filled with water capacity (12 gallons [45 liters]) is 180 lbs. (82 kg).*

- Make sure all the feet on the bottom of the unit are positioned securely on the countertop.

### **NOTICE**

Damage to any countertop material caused by heat generated from Hatco equipment is not covered under the Hatco warranty. Contact the manufacturer of the countertop material for application information.

4. Connect a flexible water supply line to the water inlet on the bottom of the unit using 1/4" NPT adapter with flare connection (or by using the accessory 1/4" inlet tubing supplied by Hatco).

*NOTE: Water inlet and drain connections must be made with flexible hose.*

*NOTE: If required, a ball valve or gate valve, line strainer, union(s) and vacuum breaker or other anti-siphon device must be supplied by plumber or installer.*

### **NOTICE**

Do not over-tighten plumbing connections. Over-tightening may cause leaks.

Incoming water supply must not exceed 140°F (60°C). Water pressure must be at least 35 psi (241 kPa) and not exceed 80 psi (552 kPa).

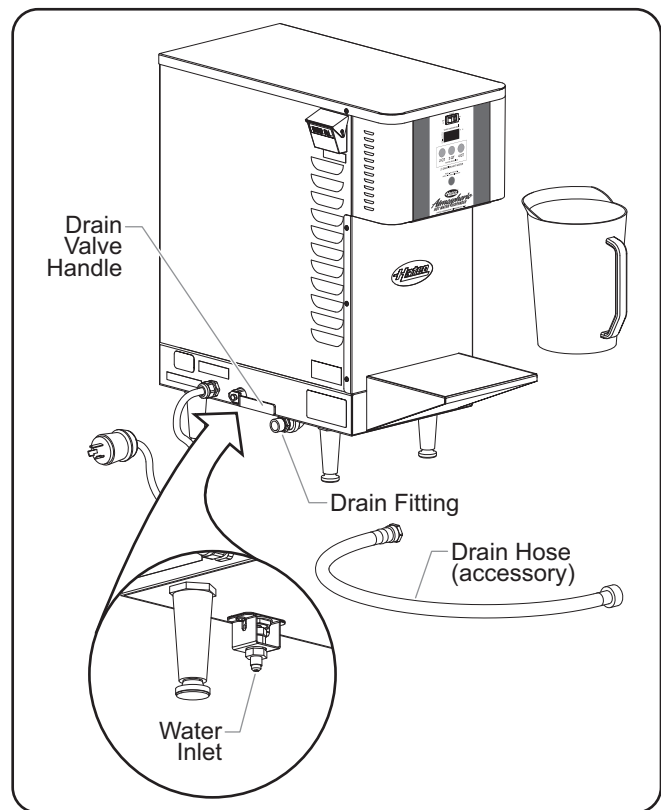

AWD-12 Installation

5. Tighten connections securely.
6. Turn on water supply and check for leaks.
  - A drain fitting is located under the unit for manually draining the dispenser. A male hose connector is included. See MAINTENANCE for draining information.

*NOTE: A 3/4" (19 mm) flexible hose may be connected to the heater drain and run to an open sight drain. The drain should not be connected permanently to the sanitary drain system. Check local plumbing code for proper drain installation.*

## General

Use the following procedures to operate a Atmospheric Hot Water Dispenser.



### WARNING

Read all safety messages in the Important Safety Information section before operating this equipment.

Hatco Corporation is not responsible for the actual food product serving temperature. It is the responsibility of the user to ensure that the food product is held and served at a safe temperature.

## Startup

NOTE: Make sure the drain valve handle is in the horizontal (closed) position.

1. Plug unit into a properly grounded electrical receptacle of the correct voltage, size and plug configuration. See the SPECIFICATIONS section for details.
2. Move the POWER ON/OFF (I/O) switch to the ON (I) position.
  - The WATER TEMPERATURE display will light up to indicate power is supplied to the unit.



### CAUTION

**BURN HAZARD: Some exterior surfaces on unit will get hot. Use caution when touching these areas.**

3. The unit is ready to dispense water when the display shows the setpoint water temperature (the factory default setpoint temperature is 195°F [91°C]).
  - The WATER TEMPERATURE display will show “E3” while the water begins to fill the tank.
  - The WATER TEMPERATURE display will show the current water temperature and a red light will glow in the upper left-hand corner of the digital temperature display when the heating elements are energized.
  - The water fills the tank until it is full and the heating elements heat the water until the water temperature reaches the setpoint temperature.

NOTE: A temperature setting higher than 195°F (91°C) will cause nuisance tripping of the high limit switch and is not recommended. If temperature adjustments are required see “Programming The Dispenser.” To reset the high limit switch, see “Resetting The High Temperature Limit Switch.”

## Shutdown

1. Move the POWER ON/OFF (I/O) switch to the OFF (O) position.
  - The WATER TEMPERATURE display will turn off to indicate power has been shut off to the unit.

## Dispensing Hot Water

1. Place the proper water container for holding hot water on the shelf (or below the dispenser) before dispensing.

NOTE: The shelf can be removed to dispense water into larger containers. To remove the shelf, lift the shelf up and off the mounting screwheads.

2. Push the appropriate button on the electronic temperature controller to fill a container. Dispensing is controlled by the four dispensing buttons on the front of the unit.
  - The three VOLUME SELECTION buttons underneath the display dispense at pre-measured quantities of 2QT, 3QT, and 4QT as marked.
    - 2QT = 2 quarts (1.9 liters)
    - 3QT = 3 quarts (2.8 liters)
    - 4QT = 4 quarts (3.8 liters)
  - The red button dispenses and stops water manually.
    - Press and hold to dispense water manually. Water will continue to flow until the red button is released.
    - Press once after pressing one of the programmed dispense buttons to manually stop dispensing.

NOTE: The dispense amounts can be adjusted if required. See “Programming The Dispenser.”

NOTE: Refer to the OPTIONS AND ACCESSORIES section for alternate, premeasure dispensing volumes.

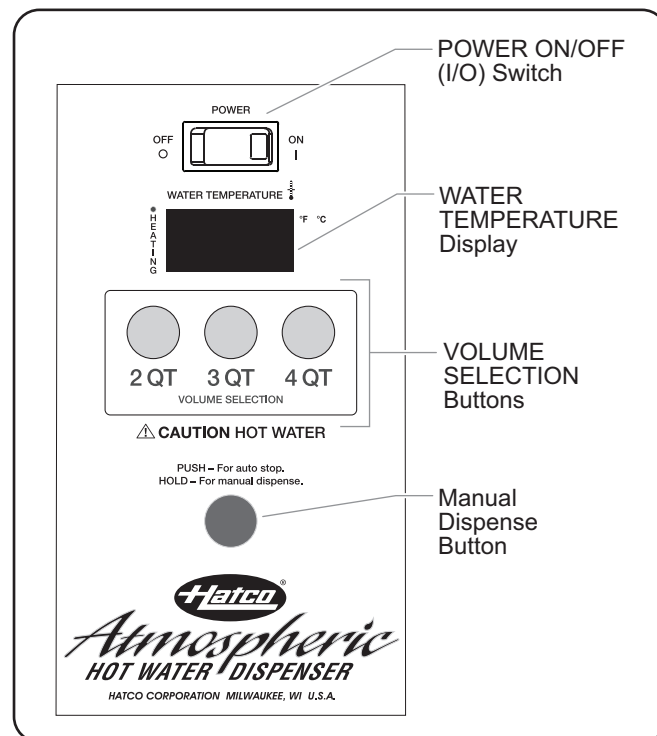

Control Panel

# OPERATION

## Programming the Dispenser



### WARNING

**ELECTRIC SHOCK HAZARD:** Turn OFF power switch, unplug power cord, and allow unit to cool before performing any cleaning, adjustments, or maintenance.

### Dipswitch Panel

A dipswitch panel is located on the back of the control board which is behind the front panel graphic overlay. The dip switches have the following functions:

**Dipswitch “1”** is used to switch between operational mode (RUN) and programming mode (PGM).

**Dipswitch “2”** is used to change the display from F° to C°.

**Dipswitch “3”** is used to select the type of operation and must be switched to the AWD position for the dispenser to operate.

**Dipswitch “4”** is not used (can be in either position).

### Changing Temperature Display from F° to C°

1. Turn the POWER ON/OFF (I/O) switch to the OFF (O) position, and unplug the unit from the electrical receptacle.
2. Remove the two screws and slide off the top red panel.
3. Move dipswitch “2” to the C position to change the display from Fahrenheit (F°) to Celsius (C°).
4. Re-install the top red panel.
5. Plug the unit into the proper electrical receptacle and turn the POWER ON/OFF (I/O) switch to the ON (I) position.

### Changing Temperature Setpoint

1. Turn the POWER ON/OFF (I/O) switch to the OFF (O) position and unplug the unit from the electrical receptacle.
2. Remove the two screws and slide off the top red panel.
3. Move dipswitch “1” to the PGM position.
4. Place the top red panel on unit.



### CAUTION

#### Never operate unit without cover installed.

5. Plug the unit into the proper electrical receptacle and turn the POWER ON/OFF (I/O) switch to the ON (I) position.
  - The display will show  $t5P$  (temperature setpoint). This indicates the beginning of the programming sequence.
  - Press the red manual dispense button once and the display will show the current temperature setpoint.
6. Use the 2QT and 3QT buttons to adjust the temperature setpoint up or down.
7. When the desired setpoint is shown, press the red manual dispense button to save the change to memory.

*NOTE: If no buttons are pressed for a period of 15 seconds, the program will automatically jump to the end of the programming sequence, and the display will read END.*

8. Turn the POWER ON/OFF (I/O) switch to the OFF (O) position and unplug the unit from the electrical receptacle.
9. Remove the top red panel.
10. Move dipswitch “1” back to the RUN position.
11. Re-install the top red panel using the two screws.
12. Plug the unit into the proper electrical receptacle and turn the POWER ON/OFF (I/O) switch to the ON (I) position.

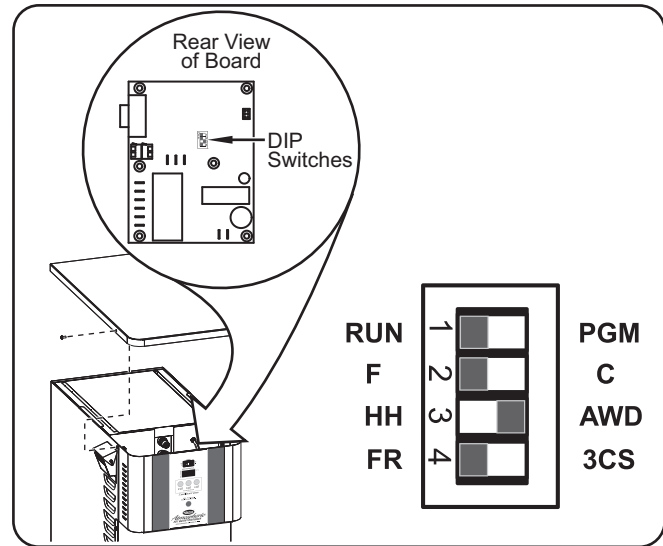

Dipswitch Controls

### Changing Dispense Time (Water quantity)

Use the following procedure to modify the amount of water the 2QT, 3QT, and/or 4QT buttons dispense.

1. Turn the POWER ON/OFF (I/O) switch to the OFF (O) position, and unplug the unit from the electrical receptacle.
2. Remove the two screws and slide off the top red panel.
3. Move dipswitch “1” to the PGM position.
4. Place the top red panel on unit.



### CAUTION

#### Never operate unit without cover installed.

5. Plug the unit into the proper electrical receptacle and turn the POWER ON/OFF (I/O) switch to the ON (I) position.
  - The display will show  $t5P$  (temperature setpoint). This indicates the beginning of the programming sequence.
6. Press the red manual dispense button to scroll to the desired dispense button to be programmed. The display will identify the VOLUME SELECTION button by number:
  - “1” = 2QT VOLUME SELECTION Button
  - “2” = 3QT VOLUME SELECTION Button
  - “3” = 4QT VOLUME SELECTION Button
7. Press the red manual dispense button again to display the current dispense time for the specific VOLUME SELECTION Button.
8. Use the 2QT and 3QT buttons to adjust the dispense time up or down (displayed in seconds by half-second intervals).
9. When the desired dispense time is shown, press the red manual dispense button to save the change to memory and to scroll to the next desired VOLUME SELECTION button.
10. Repeat step 6 with the next desired dispense button or turn the POWER ON/OFF (I/O) switch to the OFF (O) position, and unplug the unit from the electrical receptacle.
11. Remove the top red panel.
12. Move dipswitch “1” back to the RUN position.
13. Re-install the top red panel using the two screws.
14. Plug the unit into the proper electrical receptacle and turn the POWER ON/OFF (I/O) switch to the ON (I) position.

## General

Hatco Atmospheric Hot Water Dispensers are designed for maximum durability and performance with minimum maintenance.

### **⚠ WARNING**

#### ELECTRIC SHOCK HAZARD:

- Turn OFF power switch, unplug power cord, and allow unit to cool before performing any cleaning, adjustments, or maintenance.
- **DO NOT** submerge or saturate with water. Unit is not waterproof. Do not operate if unit has been submerged or saturated with water.
- Do not steam clean or use excessive water on unit.
- This unit is not “jet-proof” construction. Do not use jet-clean spray to clean this unit.
- Use only Genuine Hatco Replacement Parts when service is required. Failure to use Genuine Hatco Replacement Parts will void all warranties and may subject operators of the equipment to hazardous electrical voltage, resulting in electrical shock or burn. Genuine Hatco Replacement Parts are specified to operate safely in the environments in which they are used. Some aftermarket or generic replacement parts do not have the characteristics that will allow them to operate safely in Hatco equipment.

This unit has no “user-serviceable” parts. If service is required on this unit, contact an Authorized Hatco Service Agent or contact the Hatco Service Department at 800-558-0607 or 414-671-6350.

### **NOTICE**

Clean unit daily to avoid malfunctions and maintain sanitary operation.

## Daily Cleaning

To preserve the finish of the Atmospheric Hot Water Dispenser, it is recommended that the exterior surfaces be wiped daily with a clean, damp cloth.

### **⚠ WARNING**

Submerging or saturating unit with water will damage the unit and void unit warranty.

### **NOTICE**

Use non-abrasive cleaners and cloths only. Abrasive cleaners and cloths could scratch finish of unit, marring its appearance and making it susceptible to soil accumulation.

1. Wipe the exterior surface of the unit with a damp cloth.
2. Stubborn stains may be removed with a good stainless steel cleaner or a non-abrasive cleaner. Hard to reach areas should be cleaned with a small brush and mild soap.
3. Wipe dry the entire unit using a dry, non-abrasive cloth.

## Draining the Dispenser

It is recommended that the dispenser be drained prior to moving the unit and after performing the “Delimiting the Dispenser” procedure.

### **⚠ WARNING**

**ELECTRIC SHOCK HAZARD:** Turn OFF power switch, unplug power cord, and allow unit to cool before performing any cleaning, adjustments, or maintenance.

1. Shut off the water supply to the unit.
2. Turn the POWER ON/OFF (I/O) switch to the OFF (O) position and unplug the unit from the electrical receptacle.
3. Connect drain hose to the drain fitting on underside of unit.
4. Place open end of drain hose in a bucket or open site drain in a manner acceptable to local plumbing codes.
5. Open the drain valve by placing the drain handle in the vertical position.
6. After all of the water is drained, place the valve handle in the horizontal position to close the valve.
7. Remove the drain hose from the drain fitting.

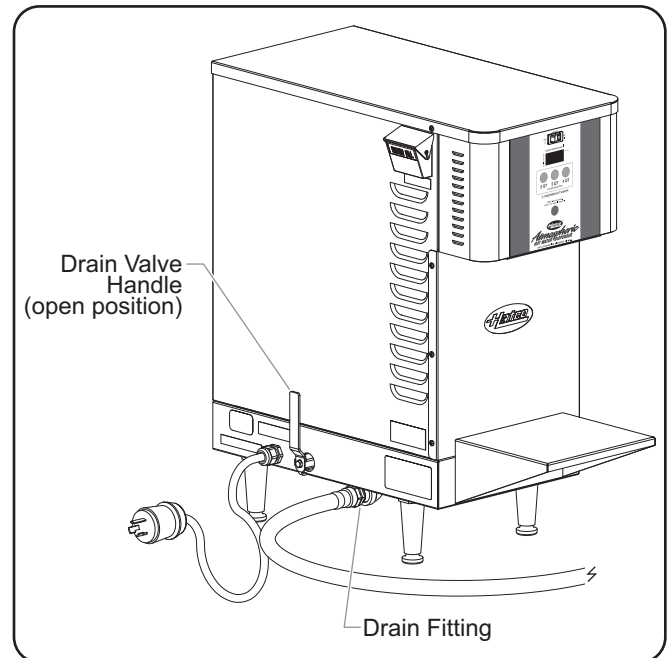

Draining the Water

# MAINTENANCE

## Deliming the Dispenser

Use the following procedure for periodic cleaning and delimiting of the water tank.

*NOTE: The lime and mineral content of the supply water will determine how often this procedure must be performed.*

*NOTE: Perform this procedure when the dispenser will not be used for a period of time, such as the end of the day.*

1. Make sure the water tank is full.
2. Turn the POWER ON/OFF (I/O) switch to the OFF (O) position.
3. Drain 3 gallons (11 liters) of water out of the 12 gallon (45 liter) water tank (see "Draining the Dispenser" in this section).
4. Fill the water tank with 3 gallons (11 liters) of off-the-shelf white vinegar (5% vinegar solution) by pouring it slowly into the fill cup on the side of the unit.

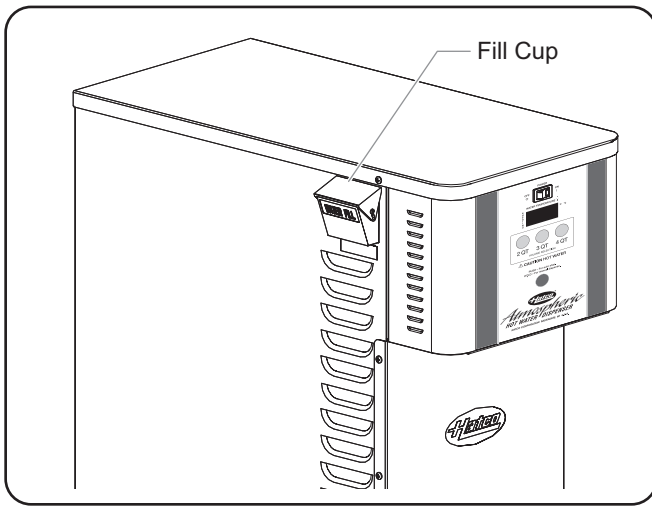

Delimiting the Dispenser

5. Turn the POWER ON/OFF (I/O) switch to the ON (I) position, and allow the unit to run at the operating temperature for 1-2 hours.
  - While the unit is at operating temperature, dispense 1/2 quart (0.4 liters) of the delimiting solution through the dispensing port. This exposes the port to the delimiting solution. (Safely discard dispensed solution.)
6. Turn the POWER ON/OFF (I/O) switch to the OFF (O) position and allow the delimiting solution to remain in the unit for a minimum of 4 hours (preferably, over night.)
7. Drain the solution from the tank (see "Draining the Dispenser" in this section).
8. Refill the unit with water by following the "Startup" procedure in the OPERATION section.
  - Dispense water out of the unit until the discharge is clear and all delimiting solution has been removed and rinsed.

*NOTE: Steps 7 and 8 may need to be repeated until all delimiting solution has been removed.*

## Resetting the High Temperature Safety Switch

The Atmospheric Water Dispenser is equipped with a manually-resettable high limit safety switch that prevents the water temperature from getting dangerously high.

If the water inside the unit exceeds 200°F (93°C), the safety high limit switch will shut the unit off. Setting the setpoint temperature over 195°F (91°C) will cause nuisance tripping of this safety switch. Hatco does not recommend adjusting the setpoint temperature above 195°F (91°C).

To reset the safety high limit switch after it activates, follow the following procedure.

1. Turn the POWER ON/OFF (I/O) switch to the OFF (O) position, unplug the unit from the power source, and allow to cool.
  - The high limit switch cannot be reset until the water temperature drops below 150°F (66°C).
2. Remove the front shelf by lifting the shelf up and off of the mounting screwheads.
3. Remove the front panel.
  - a. Remove the six screws that hold the front panel in place.
  - b. Pull the front panel down and off of the dispenser valve. The rubber grommet should stay attached to the hole in the front panel.
4. Press the small red button on the high limit safety switch until it clicks. The high limit safety switch is located on the water tank, near the left heating element and the bottom of the tank.
  - The high limit safety switch is now reset.
5. Reinstall the front panel.
  - a. Position the front panel back into place. The rubber grommet should be positioned under the dispenser valve.
  - b. Align the six screw holes on the front panel with the screw holes on the side panels, and secure in position using the six screws removed in step 3.
6. Reinstall the front shelf.

*NOTE: If the high limit safety continues to trip, verify the setpoint is 195°F (91°C) or lower. If the temperature setpoint is above 195°F (91°C), adjust the setpoint down to an acceptable level. See "Programming the Dispenser" for adjustment instructions.*

*NOTE: Contact an Authorized Service Agent if the high limit safety continues to trip and the temperature setpoint is 195°F (91°C) or below.*

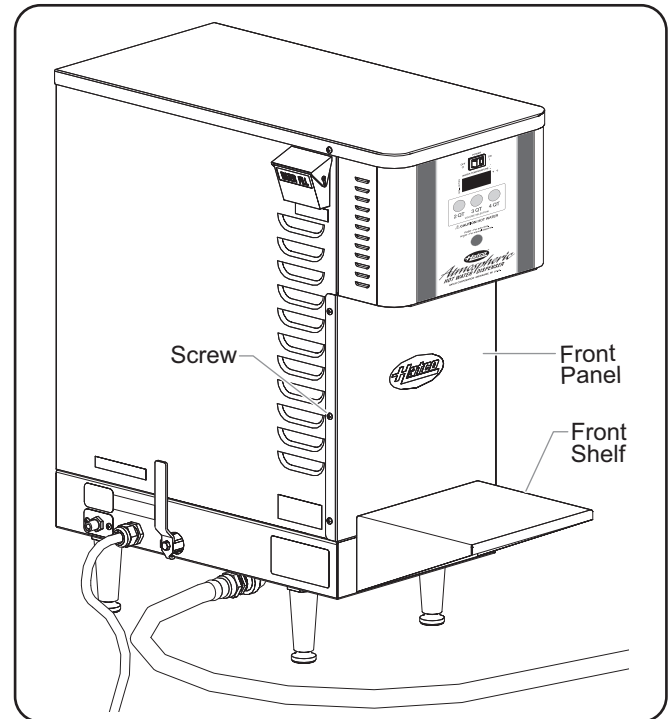

Resetting the High Temperature Safety Switch

# TROUBLESHOOTING GUIDE



This unit must be serviced by qualified personnel only. Service by unqualified personnel may lead to electric shock or burn.



**ELECTRIC SHOCK HAZARD:** Turn OFF power switch, unplug power cord, and allow unit to cool before performing any cleaning, adjustments, or maintenance.

Symptom	Probable Cause	Corrective Action
Unit is not working at all.	Unit not turned on.	Move POWER ON/OFF (I/O) switch to the ON (I) position.
	Unit not plugged in.	Plug unit into proper power supply.
	Circuit breaker tripped.	Reset circuit breaker. If circuit breaker continues to trip, Contact Authorized Service Agent or Hatco for assistance.
	Low-water cut-off activated.	Make sure the unit is supplied with water.
	POWER ON/OFF (I/O) switch is defective.	Contact Authorized Service Agent or Hatco for assistance.
Unit does not dispense water.	Drain valve handle is in the open (vertical) position.	Make sure the drain valve handle is in the closed (horizontal) position.
	Water supply is shut off.	Check to make sure the water supply is on.
	Dipswitch settings are incorrect.	See "Programming the Dispenser" in the OPERATION section.
	High temperature safety switch was activated.	See "Resetting the High Temperature Safety Switch" in the MAINTENANCE section.
Water not hot enough.	Temperature setpoint is set too low.	See the "Changing Temperature Setpoint" procedure in the OPERATION section.
	Heating element(s) are defective.	Contact Authorized Service Agent or Hatco for assistance.
	Incorrect (low) voltage supplied.	Contact Authorized Service Agent or Hatco for assistance.
Water is not dispensed at the designated preset amount.	The unit is programmed to dispense the improper amount of water.	See the "Changing Dispense Time" procedure in the OPERATION section.

## Error Codes

There are four error codes that may show in the display:

- E1: Indicates that the display temperature is out of range or display temperature probe is malfunctioning. Contact Authorized Service Agent or Hatco for assistance.
- E2: Indicates that the control temperature is out of range or control temperature probe is malfunctioning. Contact Authorized Service Agent or Hatco for assistance.
- E3: Indicates that the low water probe has not been satisfied. The heating elements are not yet submersed. Check water supply and water shut-off valve.
- H2O: Indicates that the inlet water solenoid has been running continuously for an excessive period of time. Check for problems with the water supply or internal water leak.

## Troubleshooting Questions?

If you continue to have problems resolving an issue, please contact the nearest Authorized Hatco Service Agency or Hatco for assistance. To locate the nearest Service Agency, log onto the Hatco website at [www.hatcocorp.com](http://www.hatcocorp.com) and click on *Find Service Agent*, or contact the **Hatco Parts and Service Team** at:

**Telephone: 800-558-0607 or 414-671-6350**

**e-mail: [partsandservice@hatcocorp.com](mailto:partsandservice@hatcocorp.com)**

## Water Filtration System

The water filtration system is available for AWD units as an accessory. The water filtration system helps eliminate sediment buildup inside of the tank leading to a longer life of the unit.

### Installing a Water Filtration System

Use the following procedure to install a water filtration system.

**NOTE:** Before beginning installation, verify that the incoming water pressure is between 35–80 psi (241–552 kPa) and the water temperature is less than 100°F (38°C).

1. Shut off the water supply to the unit.
2. Move the POWER ON/OFF (I/O) switch to the OFF (O) position, and unplug the unit from the electrical receptacle.
3. Thread a push-on fitting (included) coated with thread sealant into both the inlet and outlet ports on top of the water filtration valve. Tighten securely.

**NOTE:** To minimize the effects of restricted flow rate, use the least total amount of 1/4" (6 mm) tubing possible. The total length of tubing from the water supply to the hot water dispenser should not exceed 8' (244 cm). One 10' (305 cm) length of 1/4" (6 mm) tubing is supplied with the water filtration system.

4. Mount the water filtration valve bracket to a solid structure in a convenient location near the hot water dispenser (mounting hardware not supplied).
5. Connect the water supply to the water filtration valve inlet port using the supplied 1/4" (6 mm) tubing.

**NOTE:** To identify the inlet port, refer to the arrow on the filtration valve between the ports that indicates the water flow direction through the valve.

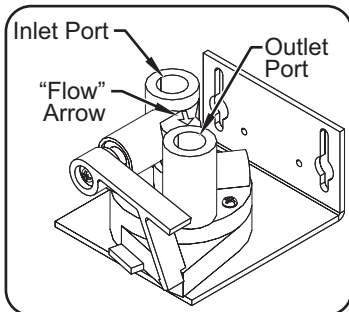

- a. Cut the 1/4" (6 mm) tubing to the appropriate length. Make sure to make clean, straight cuts on the tubing for proper connection to the push-on fittings.
  - b. Connect one end of the 1/4" (6 mm) tubing to the water supply shut-off valve and the other to the water filtration valve inlet port. An additional push-on fitting is included for the connection between the water supply shut-off valve and the tubing.
6. Connect the water filtration valve outlet port to the hot water dispenser using the supplied 1/4" (6 mm) tubing.
    - a. Cut the 1/4" (6 mm) tubing to the appropriate length. Make sure to make clean, straight cuts on the tubing for proper connection to the push-on fittings.
    - b. Connect one end of the 1/4" (6 mm) tubing to the water filtration valve outlet port and the other to the hot water dispenser inlet fitting.
  7. Install the water filter cartridge underneath the water filtration valve.
    - a. Insert the filter up into the valve.
    - b. Twist the filter clockwise 1/4 turn until it locks into position.

8. Move both the water supply shut-off valve and the water filtration system shut-off valve to the open position, and check for proper operation/leaks.

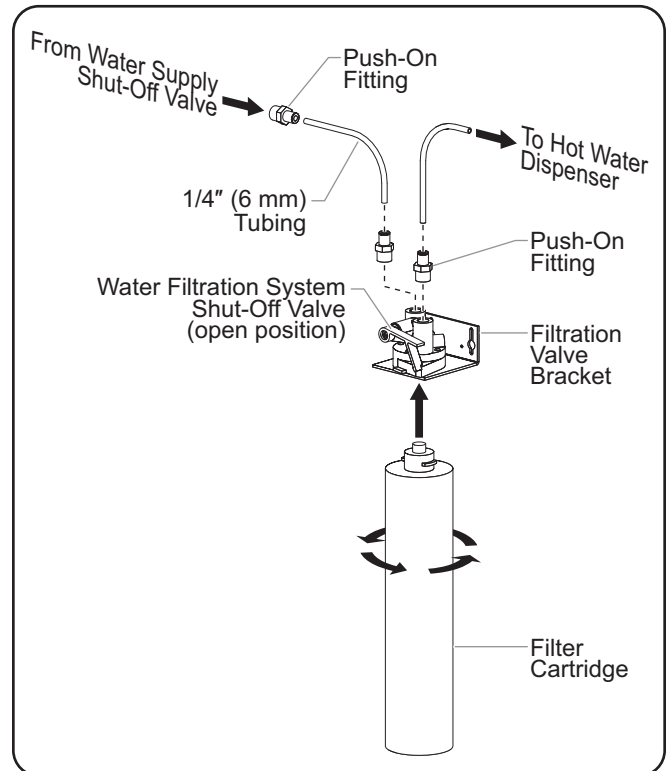

Installing a Water Filtration System

**NOTE:** The water filter cartridge should be replaced after every 15,000 gallons (56,000 liters) of use or at least once per year. Order Hatco P/N 03.05.116.00 for a replacement water filter cartridge.

## Locking Plug

A locking NEMA L6-30P plug is available instead of the standard NEMA 6-30 plug (not available for retrofit).

## Plumbing Kit

An accessory plumbing kit is available that includes a 10' (305 cm) long, 1/4" diameter water inlet tube and a 3' (914 mm) long drain hose. The water inlet tube connects to the water inlet fitting on the bottom of the unit. The drain hose connects to the drain fitting on the bottom of the unit.

## Anti-Splash Tube

An anti-splash tube is available as a factory-installed option. The anti-splash tube lengthens the dispensing nozzle and reduces the splashing of hot water when filling smaller containers.

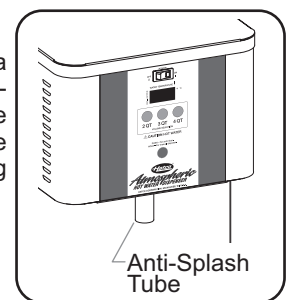

# OPTIONS AND ACCESSORIES

## Alternate Dispensing Volumes

A unit option is available that has alternate, premeasure dispensing volumes. These volumes are indicated on the control panel label.

For the alternate version, the three Volume Selection buttons underneath the display dispense at premeasure quantities of 1.5QT, 2QT, and 8QT.

- 1.5QT = 1.5 quarts (1.4 liters)
- 2QT = 2 quarts (1.9 liters)
- 8QT = 8 quarts (7.6 liters)
- The red button dispenses and stops water manually.

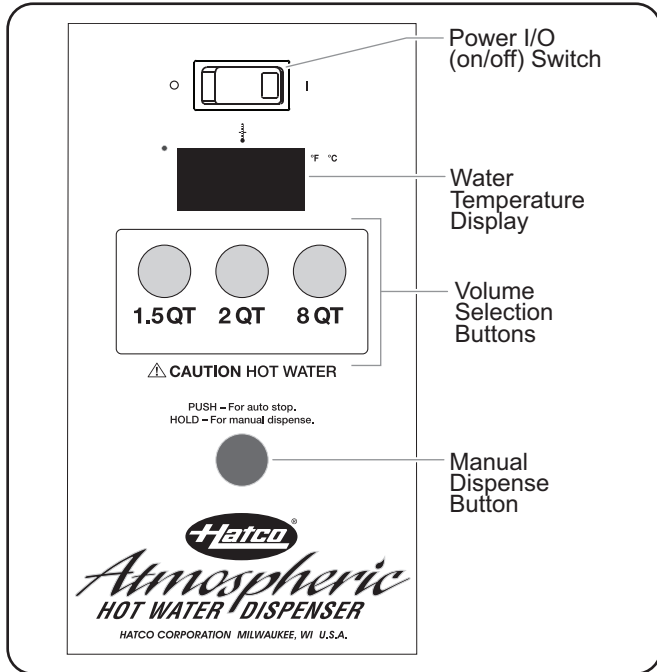

**NOTE:** The dispense amounts can be adjusted if required. See "Programming The Dispenser" in the OPERATION section.

## Wall Mount Installation

A wall-mounted shelf is available for installations that require the unit to be mounted on a wall. Mounting the unit on a wall requires special considerations and procedures due to the weight of the unit. Follow the guidelines below when determining the location for wall mounting as well as during installation.

**NOTE:** Unit weight filled with water capacity (12 gallons [45 liters]) is 180 lbs. (82 kg).

- The wall shelf must be fastened to a wall with 16" (406 mm) on center, solid wood 2x4 stud construction covered by a minimum of 1/2" (13 mm) thick sheathing.
- The wall shelf must be installed with six lag screws that are a minimum of 3/8" (9.5 mm) in diameter and 3" (76 mm) long. The screws must solidly hit the wood studs in the wall.
- Make sure the unit is at the proper height in an area convenient for use.

## Parts Included

The following parts are included with wall-mounted units.

Item	Quantity
Wall Shelf	1
Lag Screw, 3/8" x 3" (9.5 x 76 mm)	6
Flat Washer	6

## Installation Procedure

Use the following procedure to install a wall-mounted unit.

1. Make sure the mounting location meets the requirements listed previously in this procedure.
2. Determine the height for the unit installation.
  - Mark the wall at the desired height for the top of the shelf.
3. Locate the wood stud positions in the wall.
  - Determine which studs to use for installation. The studs used must allow the wall shelf to be installed with the mounting holes a distance of 16" (406 mm) on center from each other.
4. Install the wall shelf onto the wall.
  - a. Center and level the wall shelf on the desired studs. Mark the locations for the six lag screws through the holes in each side of the shelf.
  - b. Drill six 15/64" (6 mm) pilot holes in the wall at each marked location for the lag screws. The lag screws must be a minimum of 3/8" (9.5 mm) in diameter and 3" (76 mm) long.
  - c. Insert six lag screws with flat washers through the wall shelf and into the pre-drilled pilot holes in the wall.
  - d. Tighten each lag screw securely.

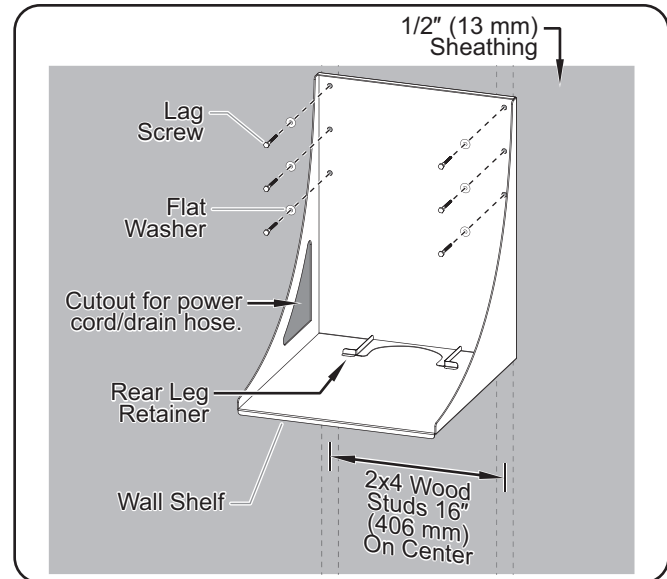

Attaching the Wall Shelf

5. Lift the unit and set it on the wall shelf with the rear legs securely behind the rear leg retainer. This step may require two people.
6. Refer to the INSTALLATION section in this manual to complete the water connection to the unit
7. Plug the unit into a properly grounded electrical receptacle of the correct voltage, size, and plug configuration. See the SPECIFICATIONS section for details.

# LIMITED WARRANTY

## 1. PRODUCT WARRANTY

Hatco warrants the products that it manufactures (the "Products") to be free from defects in materials and workmanship, under normal use and service, for a period of one (1) year from the date of purchase when installed and maintained in accordance with Hatco's written instructions or 18 months from the date of shipment from Hatco. Buyer must establish the Product's purchase date by registering the Product with Hatco or by other means satisfactory to Hatco in its sole discretion.

Hatco warrants the following Product components to be free from defects in materials and workmanship from the date of purchase (subject to the foregoing conditions) for the period(s) of time and on the conditions listed below:

**a) One (1) Year Parts and Labor PLUS One (1) Additional Year Parts-Only Warranty:**

Conveyor Toaster Elements (metal sheathed)  
Drawer Warmer Elements (metal sheathed)  
Drawer Warmer Drawer Rollers and Slides  
Strip Heater Elements (metal sheathed)  
Display Warmer Elements (metal sheathed air heating)  
Holding Cabinet Elements (metal sheathed air heating)  
Heated Well Elements — HW and HWB Series  
(metal sheathed)

**b) Two (2) Year Parts and Labor Warranty:**

Induction Ranges

**c) One (1) Year Parts and Labor PLUS Four (4) Years Parts-Only Warranty:**

3CS and FR Tanks

**d) One (1) Year Parts and Labor PLUS Nine (9) Years Parts-Only Warranty on:**

Electric Booster Heater Tanks  
Gas Booster Heater Tanks

**e) Ninety (90) Day Parts-Only Warranty:**

Replacement Parts

THE FOREGOING WARRANTIES ARE EXCLUSIVE AND IN LIEU OF ANY OTHER WARRANTY, EXPRESSED OR IMPLIED, INCLUDING BUT NOT LIMITED TO ANY IMPLIED WARRANTY OF MERCHANTABILITY OR FITNESS FOR A PARTICULAR PURPOSE OR PATENT OR OTHER INTELLECTUAL PROPERTY RIGHT INFRINGEMENT. Without limiting the generality of the foregoing, SUCH WARRANTIES DO NOT COVER: Coated incandescent light bulbs, fluorescent lights, heat lamp bulbs, coated halogen light bulbs, halogen heat lamp bulbs, xenon light bulbs, LED light tubes, glass components, and fuses; Product failure in booster tank, fin tube heat exchanger, or other water heating equipment caused by liming, sediment buildup, chemical attack, or freezing; or Product misuse, tampering or misapplication, improper installation, or application of improper voltage.

## 2. LIMITATION OF REMEDIES AND DAMAGES

Hatco's liability and Buyer's exclusive remedy hereunder will be limited solely, at Hatco's option, to repair or replacement using new or refurbished parts or Product by Hatco or a Hatco-authorized service agency (other than where Buyer is located outside of the United States, Canada, United Kingdom, or Australia, in which case Hatco's liability and Buyer's exclusive remedy hereunder will be limited solely to replacement of part under warranty) with respect to any claim made within the applicable warranty period referred to above. Hatco reserves the right to accept or reject any such claim in whole or in part. In the context of this Limited Warranty, "refurbished" means a part or Product that has been returned to its original specifications by Hatco or a Hatco-authorized service agency. Hatco will not accept the return of any Product without prior written approval from Hatco, and all such approved returns shall be made at Buyer's sole expense. HATCO WILL NOT BE LIABLE, UNDER ANY CIRCUMSTANCES, FOR CONSEQUENTIAL OR INCIDENTAL DAMAGES, INCLUDING BUT NOT LIMITED TO LABOR COSTS OR LOST PROFITS RESULTING FROM THE USE OF OR INABILITY TO USE THE PRODUCTS OR FROM THE PRODUCTS BEING INCORPORATED IN OR BECOMING A COMPONENT OF ANY OTHER PRODUCT OR GOODS.

# AUTHORIZED PARTS DISTRIBUTORS • AUTORISÉS DISTRIBUTEURS DE PIÈCES

## ALABAMA

Jones McLeod Appl. Svc.  
Birmingham 205-251-0159

## ARIZONA

Service Solutions Group  
Phoenix 602-234-2443

Byassee Equipment Co.  
Phoenix 602-252-0402

## CALIFORNIA

Industrial Electric  
Commercial Parts & Service, Inc.  
Huntington Beach 714-379-7100

Chapman Appl. Service  
San Diego 619-298-7106

P & D Appliance  
Commercial Parts & Service, Inc.  
S. San Francisco 650-635-1900

## COLORADO

Hawkins Commercial Appliance  
Englewood 303-781-5548

## FLORIDA

Whaley Foodservice Repair  
Jacksonville 904-725-7800

Whaley Foodservice Repair  
Orlando 407-757-0851

B.G.S.I.  
Pompano Beach 954-971-0456

Comm. Appliance Service  
Tampa 813-663-0313

## GEORGIA

TWC Services  
Mableton 770-438-9797

Heritage Service Group  
Norcross 866-388-9837

Southeastern Rest. Svc.  
Norcross 770-446-6177

## HAWAII

Burney's Comm. Service, Inc.  
Honolulu 808-848-1466

Food Equip Parts & Service  
Honolulu 808-847-4871

## ILLINOIS

Parts Town  
Lombard 708-865-7278

Eichenauer Elec. Service  
Decatur 217-429-4229

Midwest Elec. Appl. Service  
Elmhurst 630-279-8000

Cone's Repair Service  
Moline 309-797-5323

## INDIANA

GCS Service  
Indianapolis 800-727-8710

## IOWA

Goodwin Tucker Group  
Des Moines 515-262-9308

## KENTUCKY

Service Solutions Group  
Lexington 859-254-8854

Service Solutions Group  
Louisville 502-451-5411

## LOUISIANA

Chandlers Parts & Service  
Baton Rouge 225-272-6620

## MARYLAND

Electric Motor Service  
Baltimore 410-467-8080

GCS Service  
Silver Spring 301-585-7550

## MASSACHUSETTS

Ace Service Co., Inc.  
Needham 781-449-4220

## MICHIGAN

Bildons Appliance Service  
Detroit 248-478-3320

Commercial Kitchen Service  
Bay City 989-893-4561

Midwest Food Equip. Service  
Grandville 616-261-2000

## MINNESOTA

GCS Service  
Minnetonka 800-822-2303  
x20365

## MISSOURI

General Parts  
Kansas City 816-421-5400

Commercial Kitchen Services  
St. Louis 314-890-0700

Kaemmerlen Parts & Service  
St. Louis 314-535-2222

## NEBRASKA

Anderson Electric  
Omaha 402-341-1414

## NEVADA

Burney's Commercial  
Las Vegas 702-736-0006

Hi. Tech Commercial Service  
N. Las Vegas 702-649-4616

## NEW JERSEY

Jay Hill Repair  
Fairfield 973-575-9145

Service Plus  
Flanders 973-691-6300

## NEW YORK

Acme American Repairs, Inc.  
Jamaica 718-456-6544

Alpro Service Co.  
Maspeeth 718-386-2515

Appliance Installation  
Buffalo 716-884-7425

Duffy's Equipment Services, Inc.  
Buffalo 800-836-1014

3Wire Northern  
Plattsburgh 800-634-5005

Duffy's Equipment Services, Inc.  
Sauquoit 800-836-1014

J.B. Brady, Inc.  
Syracuse 315-422-9271

## NORTH CAROLINA

Authorized Appliance  
Charlotte 704-377-4501

## OHIO

Akron/Canton Comm. Svc. Inc.  
Akron 330-753-6634

Service Solutions Group  
Cincinnati 513-772-6600

Commercial Parts and Service  
Columbus 614-221-0057

Electrical Appl. Repair Service  
Brooklyn Heights 216-459-8700

E. A. Wichman Co.  
Toledo 419-385-9121

## OKLAHOMA

Hagar Rest. Service, Inc.  
Oklahoma City 405-235-2184

Krueger, Inc.  
Oklahoma City 405-528-8883

## OREGON

Ron's Service, Inc.  
Portland 503-624-0890

## PENNSYLVANIA

Elmer Schultz Services  
Philadelphia 215-627-5401

FAST Comm. Appl. Service  
Philadelphia 215-288-4800

Appliance Installation & Service  
Pittsburgh 412-809-0244

K & D Service Co.  
Harrisburg 717-236-9039

Electric Repair Co.  
Reading 610-376-5444

## RHODE ISLAND

Marshall Electric Co.  
Providence 401-331-1163

## SOUTH CAROLINA

Whaley Foodservice Repair  
Lexington 803-996-9900

## TENNESSEE

Camp Electric  
Memphis 901-527-7543

## TEXAS

GCS Service  
Fort Worth 800-433-1804

Armstrong Repair Service  
Houston 713-666-7100

Cooking Equipment Specialist  
Mesquite 972-686-6666

Commercial Kitchen Repair Co.  
San Antonio 210-735-2811

## UTAH

La Monica's Rest. Equip. Service  
Murray 801-263-3221

## VIRGINIA

Daubers  
Norfolk 757-855-4097

Daubers  
Springfield 703-866-3600

## WASHINGTON

3Wire Restaurant Appliance  
Seattle 800-207-3146

## WISCONSIN

A.S.C., Inc.  
Madison 608-246-3160

A.S.C., Inc.  
Milwaukee 414-543-6460

## CANADA

### ALBERTA

Key Food Equipment Service  
Edmonton 780-438-1690

### BRITISH COLUMBIA

Key Food Equipment Service  
Vancouver 604-433-4484

Key Food Equipment Service  
Victoria 250-920-4888

### MANITOBA

Air Rite, Inc.  
Winnipeg 204-895-2300

### NEW BRUNSWICK

EMR Services, Ltd.  
Moncton 506-855-4228

### ONTARIO

R.G. Henderson Ltd.  
Toronto 416-422-5580

Choquette - CKS, Inc.  
Ottawa 613-739-8458

### QUÉBEC

Choquette - CKS, Inc.  
Montreal 514-722-2000

Choquette - CKS, Inc.  
Québec City 418-681-3944

## UNITED KINGDOM

Marren Group  
Northants +44(0)1933 665313

**HATCO CORPORATION**

**P.O. Box 340500**

**Milwaukee, WI 53234-0500 U.S.A.**

**800-558-0607 414-671-6350**

**partsandservice@hatcocorp.com**

**www.hatcocorp.com**

**Register your unit online!**

See IMPORTANT OWNER INFORMATION  
section for details.

**S'inscrire en ligne!**

Lisez la section INFORMATIONS IMPORTANTES  
POUR LE PROPRIÉTAIRE pour plus de informations.