



IMPORTANT NOTE:

Locate the Specification Label on unit to determine exact Model Name and electrical specifications. This information is needed to identify the correct replacement parts. See exploded view illustration(s) for Specification Label location.



Use of replacement parts other than those supplied by Hatco Corporation may result in damage to unit or injury to personnel and will void all warranties.

Ultra-Glo® Portable Foodwarmers

UGFF Series

<u>Model Name</u>	<u>Page</u>	<u>Model Name</u>	<u>Page</u>
UGFF-.5P	2	UGFFB	4
UGFF	2	UGFFBL	4
UGFFL	2		

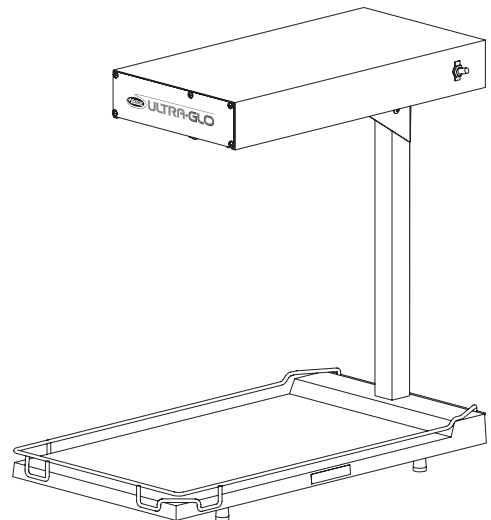
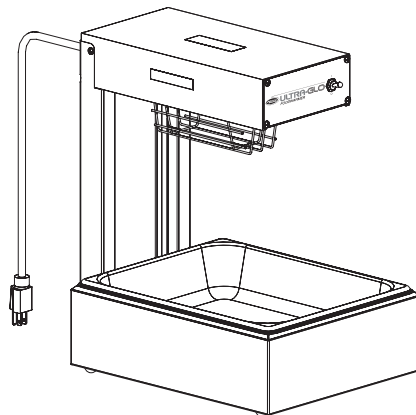

Replacement Parts List

Hatco Ultra-Glo® Portable Foodwarmers

UGFF Series — UGFF-.5P, UGFF, and UGFFL Models

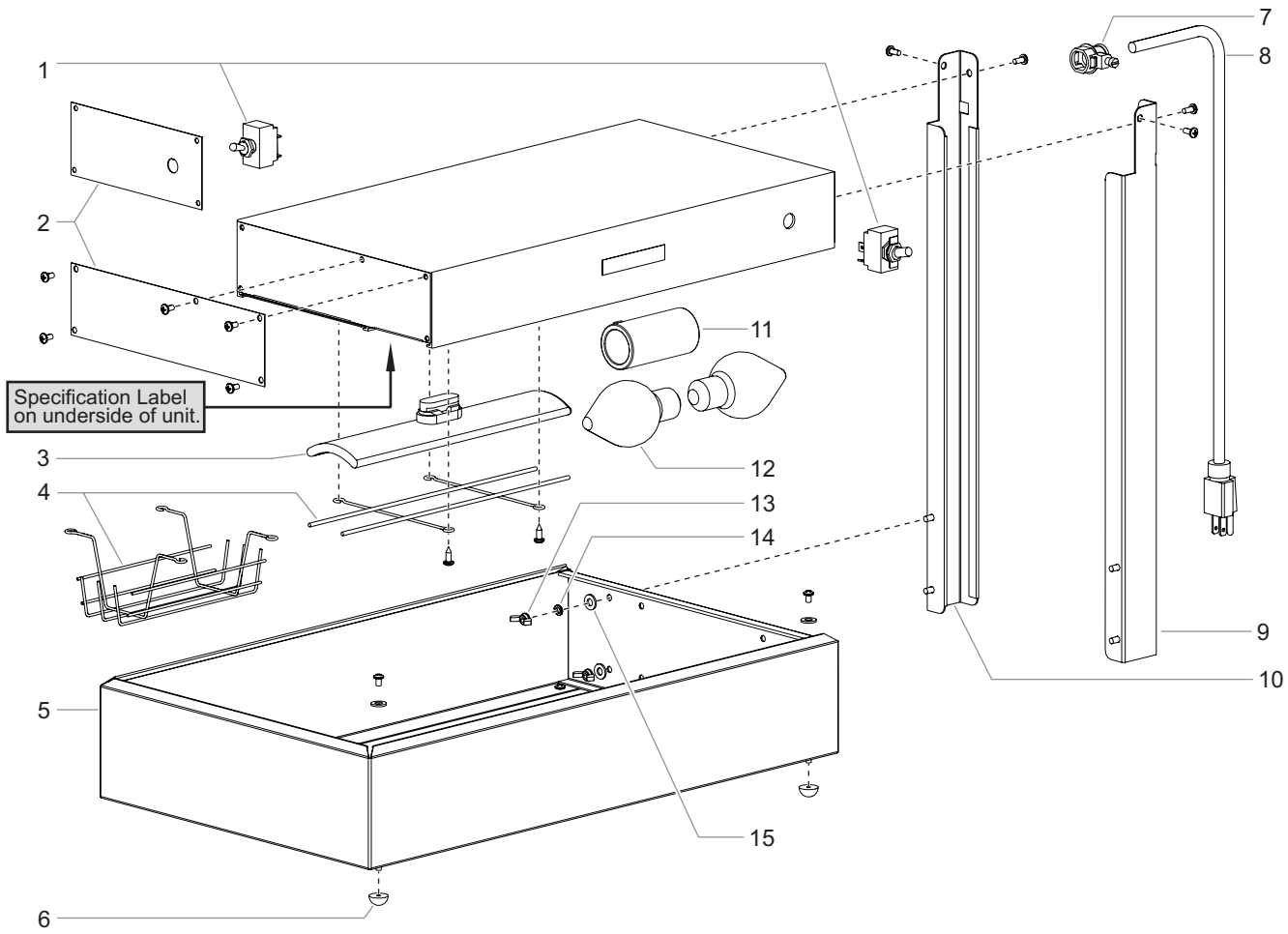

Item	Description	Part Number	Qty.
1	Toggle Switch		
	UGFF-.5P	R02.19.016.00	1
	UGFF and UGFFL	R02.19.008A.00	1
2	Control Label		
	UGFF-.5P	07.01.363.00	1
	UGFF	07.01.269.00	1
	UGFFL	07.01.268.00	1
3	Ceramic Element		
	UGFF-.5P, 120 V	R02.07.006.00	1
	UGFF and UGFFL		
	120 V	R02.07.001.01	1
	100 V	R02.07.014.00	1
	220, 220-230 V	R02.07.015.00	1
	230-240, 240 V	R02.07.003.00	1
4	Wire Guard		
	UGFF-.5P	04.25.225.00	1
	UGFF and UGFFL	04.08.117.00	1
5	Base Assembly		
	UGFF-.5P	04.09.567.00	1
	UGFF and UGFFL	04.09.520.00	1
6	Foot, Rubber	R05.30.068.00	1
7	Cord Grip	02.20.212.00	1
8	Power Cord		
	100, 120 V; NEMA 5-15P	R02.18.030.00	1
	220, 220-230 V; CEE 7/7 Schuko	02.18.077.00	1
	230-240, 240 V; BS-1363	02.18.066.00	1

Item	Description	Part Number	Qty.
9	Support Post, Right Side		
	UGFF-.5P	04.09.523.00	1
	UGFF and UGFFL	04.09.525.00	1
10	Support Post, Left Side		
	UGFF-.5P	04.09.524.00	1
	UGFF and UGFFL	04.09.526.00	1
11	Light Socket	02.30.047.00	1
12	Light Bulbs (UGFFL Models)		
	100, 120 V	02.30.043.00	2
	220, 220-230, 230-240, 240 V	02.30.058.00	2
13	Wing Nut	05.04.450.00	4
14	Lock Washer	05.11.017.00	4
15	Washer	05.11.029.00	4
	Wiring Diagrams		
	UGFF-.5P and UGFF, 120 V	10-01-514	
	UGFF, 100 V	10-02-409	
	UGFF, 220 V	10-01-514	
	UGFF, 220-230 V	HS1-4194	
	UGFF, 230-240 V	HS1-4195	
	UGFF, 240 V	HS1-3356	
	UGFFL, 120 V	HS1-3306	
	UGFFL, 100 V	10-02-410	
	UGFFL, 220 V	HS1-3357	
	UGFFL, 220-230 V	HS1-4196	
	UGFFL, 230-240 V	HS1-4197	
	UGFFL, 240 V	HS1-3358	

The shaded areas contain information for **International models only**.

NOTE: The last four digits in a ten digit numerical serial number are the manufacturing date code.

Example: Serial number 962506**1931** has a date code of "1931" which indicates the following: 1931



Hatco Ultra-Glo® Portable Foodwarmers

UGFFB Series — UGFFB and UGFFBL Models

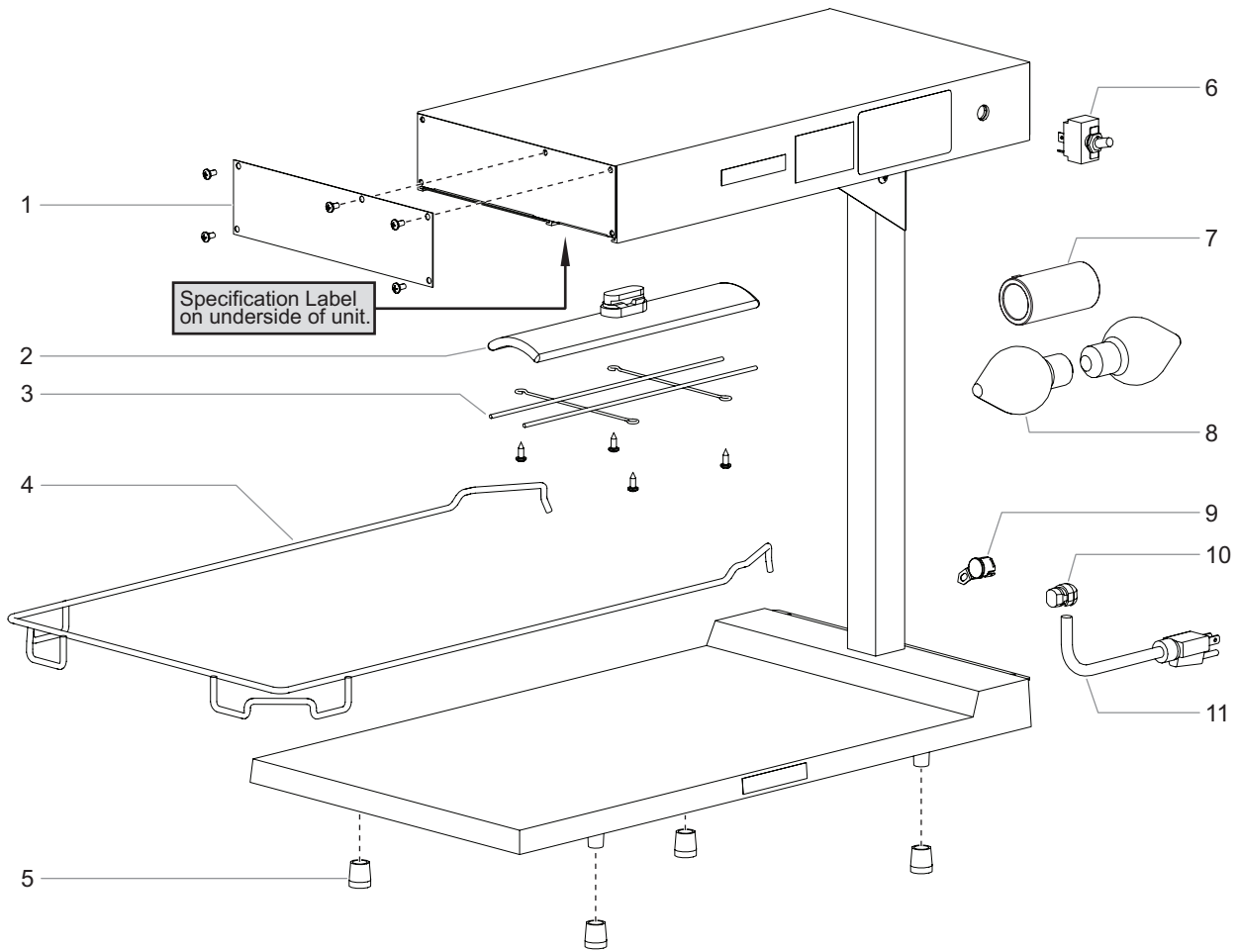

Item	Description	Part Number	Qty.
1	Control Label	07.01.268.00	1
2	Ceramic Element		
	120 V	R02.07.001.01	1
	100 V	R02.07.014.00	1
	220, 220–230, 230–240, 240 V	R02.07.003.00	1
3	Wire Guard	04.08.117.00	1
4	Pan Rail	04.09.410.00	1
5	Foot, Rubber	05.06.038.00	4
6	Toggle Switch	R02.19.008A.00	1
7	Light Socket	02.30.047.00	1
8	Light Bulbs		
	100 and 120 V	02.30.043.00	2
	220, 220–230, 230–240, 240 V	02.30.058.00	2
9	Thermostat	02.16.029.00	1
10	Cord Grip		
	100, 120 V	02.20.330.00	1
	220, 220–230, 230–240, 240 V	02.20.212.00	1

Item	Description	Part Number	Qty.
11	Power Cord		
	100, 120 V; NEMA 5-15P	R02.18.030.00	1
	220, 220–230 V; CEE 7/7 Schuko	02.18.077.00	1
	230–240, 240 V; BS-1363	02.18.066.00	1
	Wiring Diagrams		
	UGFFB, 120 V	HS1-2022	
	UGFFB, 100 V	10-01-492	
	UGFFB, 220 V	HS1-3319	
	UGFFB, 220–230 V	HS1-4198	
	UGFFB, 230–240 V	HS1-4199	
	UGFFB, 240 V	HS1-3320	
	UGFFBL, 120 V	HS1-1274	
	UGFFBL, 100 V	10-01-493	
	UGFFBL, 220 V	HS1-3321	
	UGFFBL, 220–230 V	HS1-4200	
	UGFFBL, 230–240 V	HS1-4201	
	UGFFBL, 240 V	HS1-3322	

The shaded areas contain information for **International models only**.

NOTE: The last four digits in a ten digit numerical serial number are the manufacturing date code.

Example: Serial number 962506**1931** has a date code of “**1931**” which indicates the following: 1931

└─ Week Thirty-One
└─ Year 2019

AUTHORIZED PARTS DISTRIBUTORS • DISTRIBUTEURS DE PIÈCES AUTORISÉS

ALABAMA

Jones McLeod Appl. Svc.
Birmingham 205-251-0159

ARIZONA

Tech 24
Phoenix 602-234-2443

Byassee Equipment Co.
Phoenix 602-252-0402

CALIFORNIA

Industrial Electric
Commercial Parts & Service, Inc.
Huntington Beach 714-379-7100

Chapman Appl. Service
San Diego 619-298-7106

P & D Appliance
Commercial Parts & Service, Inc.
S. San Francisco 650-635-1900

COLORADO

Hawkins Commercial Appliance
Englewood 303-781-5548

FLORIDA

Whaley Foodservice Repair
Jacksonville 904-725-7800

Whaley Foodservice Repair
Orlando 407-757-0851

B.G.S.I./Heritage
Pompano Beach 954-971-0456

Comm. Appliance Service
Tampa 813-663-0313

GEORGIA

Heritage Service Group
Norcross 866-388-9837

HAWAII

Burney's Comm. Service, Inc.
Honolulu 808-848-1466

Food Equip Parts & Service
Honolulu 808-847-4871

ILLINOIS

Parts Town
Addison 708-865-7278

Eichenauer Elec. Service
Decatur 217-429-4229

Midwest Elec. Appl. Service
Elmhurst 630-279-8000

Cone's Repair Service
Moline 309-797-5323

IOWA

Goodwin Tucker Group
Des Moines 515-262-9308

KENTUCKY

Tech 24
Lexington 859-254-8854

Tech 24
Louisville 502-451-5411

LOUISIANA

Chandlers Parts & Service
Baton Rouge 225-272-6620

MARYLAND

Electric Motor Service
Baltimore 410-467-8080

MASSACHUSETTS

Ace Service Co., Inc.
Needham 781-449-4220

MICHIGAN

Bildons Appliance Service
Detroit 248-478-3320

Commercial Kitchen Service
Bay City 989-893-4561

Midwest Food Equip. Service
Grandville 616-261-2000

MISSOURI

General Parts
Kansas City 816-421-5400

Commercial Kitchen Services
St. Louis 314-890-0700

Kaemmerlen Parts & Service
St. Louis 314-535-2222

NEBRASKA

Anderson Electric
Omaha 402-341-1414

NEVADA

Burney's Commercial
Las Vegas 702-736-0006

Hi. Tech Commercial Service
N. Las Vegas 702-649-4616

NEW JERSEY

Jay Hill Repair
Fairfield 973-575-9145

Service Plus
Flanders 973-691-6300

NEW YORK

Alpro Service Co.
Maspeth 718-386-2515

Duffy's - AIS
Buffalo 716-884-7425

3Wire
Plattsburgh 800-634-5005

Duffy's - AIS
Sauquoit 800-836-1014

J.B. Brady, Inc.
Syracuse 315-422-9271

NORTH CAROLINA

Authorized Appliance
Charlotte 704-377-4501

OHIO

Akron/Canton Comm. Svc. Inc.
Akron 330-753-6634

Tech 24
Cincinnati 513-772-6600

Commercial Parts and Service
Columbus 614-221-0057

Electrical Appl. Repair Service
Brooklyn Heights 216-459-8700

E. A. Wichman Co.
Toledo 419-385-9121

OKLAHOMA

Hagar Rest. Service, Inc.
Oklahoma City 405-235-2184

OREGON

General Parts Group
Portland 503-624-0890

PENNSYLVANIA

Elmer Schultz Services
Philadelphia 215-627-5401

FAST Comm. Appl. Service
Philadelphia 215-288-4800

AIS Commercial Parts and Service
Pittsburgh 412-809-0244

K & D Service Co.
Harrisburg 717-236-9039

Electric Repair Co.
Reading 610-376-5444

RHODE ISLAND

Marshall Electric Co.
Providence 401-331-1163

SOUTH CAROLINA

Whaley Foodservice Repair
Lexington 803-996-9900

TENNESSEE

Camp Electric
Memphis 901-527-7543

TEXAS
Armstrong Repair Service
Houston 713-666-7100

Cooking Equipment Specialist
Mesquite 972-686-6666

Commercial Kitchen Repair Co.
San Antonio 210-735-2811

UTAH

La Monica's Rest. Equip. Service
Murray 801-263-3221

VIRGINIA

Daubers
Norfolk 757-855-4097

Daubers
Springfield 703-866-3600

WASHINGTON

3Wire
Seattle 800-207-3146

WISCONSIN

A.S.C., Inc.
Madison 608-246-3160

A.S.C., Inc.
Milwaukee 414-543-6460

CANADA

ALBERTA

Key Food Equipment Service
Edmonton 780-438-1690

BRITISH COLUMBIA

Key Food Equipment Service
Vancouver 604-433-4484

Key Food Equipment Service
Victoria 250-920-4888

MANITOBA

Air Rite, Inc.
Winnipeg 204-895-2300

NEW BRUNSWICK

EMR Services, Ltd.
Moncton 506-855-4228

ONTARIO

R.G. Henderson Ltd.
Toronto 416-422-5580

Choquette - CKS, Inc.
Ottawa 613-739-8458

QUÉBEC

Choquette - CKS, Inc.
Montreal 514-722-2000

Choquette - CKS, Inc.
Québec City 418-681-3944

UNITED KINGDOM

Marren Group
Northants +44(0)1933 665313

HATCO CORPORATION

P.O. Box 340500

Milwaukee, WI 53234-0500 U.S.A.

800-558-0607 414-671-6350

partsandservice@hatcocorp.com

www.hatcocorp.com



24 Hour 7 Day Parts and Service
Assistance available in the United States
and Canada by calling 800-558-0607.