

27kW - 208V - 1Ø - 129.8A

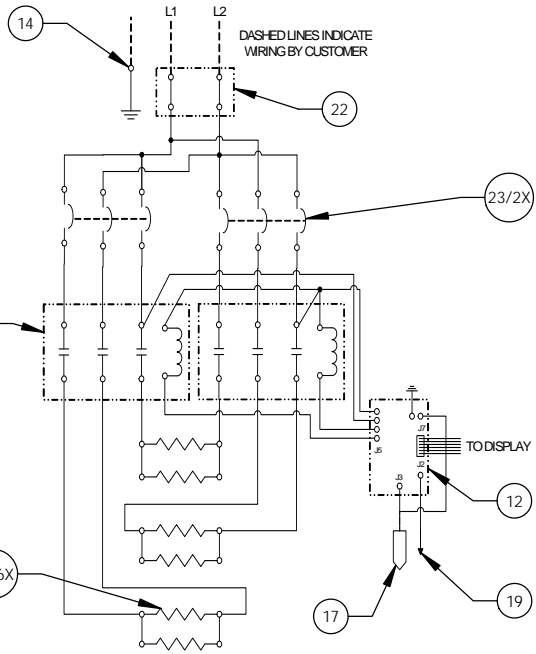

ITEM NO.	QTY	PART NO.	MATERIAL	DESCRIPTION
1	1	J6-6 TANK	304L S/S	TANK ASSEMBLY
2	1	J6 INLET	BRASS	3/4" MNPT INLET
3	1	J6 OUTLET	BRASS	3/4" MNPT OUTLET
4	1		BRASS	3/4" FNPT FOR RELIEF VALVE
5	1	100XL 75 150LB	BRONZE	RELIEF VALVE SET AT 150PSI, 210°F
6	1	J6-6 JACKET	304 S/S	TOP COVER ASSEMBLY
7	1	J6-6 FRONT COVER	304 S/S	FRONT COVER ASSEMBLY
8	1	J6-6 BASE	304 S/S	BASE ASSEMBLY
9	1		FOAM	INSULATION
10	4	61649NOBN514	PLASTIC	ADJUSTABLE LEGS
11	6	C1315-17	BRASS PLUG & COPPER SHEATH	HEATING ELEMENT - 1-7/8" HEX 6000W @ 240V/4500W @ 208V
12	1	T1000	VARIOUS	CONTROL MODULE
13	2	C25DNF340B	VARIOUS	MAGNETIC CONTACTOR 50A (RESISTIVE) - 240V
14	1	KA4C	COPPER	GROUND LUG
15	1	J6-6 CONTROL PLATE	GALVANNEAL	ELECTRICAL MOUNTING PANEL
16	1	TD1000	VARIOUS	DIGITAL DISPLAY MODULE
17	1	P65	VARIOUS	PROBE ASSEMBLY
18	1	OVERLAY J MODEL	LEXAN	OVERLAY FOR DISPLAY MODULE
19	1		VARIOUS	LEAK DETECTION SENSOR
20	1	ITD405	VARIOUS	T&P GAUGE 30-240°F/0-200PSI
21	1	N45BU	BRONZE	PRESS. REDUCING VALVE 25-75PSI
22	1	PDB310-1X6-3	VARIOUS	POWER DISTRIBUTION BLOCK 310A, 3-POLE, 1 PRIM., 6 SEC.
23	2	CB 60 AMP	VARIOUS	POWER CIRCUIT BREAKER 60A, 3-POLE, 240V
24	1	POLY PRO	POLYPROPYLENE	INSULATING BOARD

- NOTES:
- TANK IS DESIGNED, FABRICATED, AND STAMPED IAW ASME SECTION VIII CODE, LATEST ADDENDA.
 - TANK IS DESIGNED FOR 150PSI AND PRESSURE TESTED AT 225PSI.
 - PROBE ASSEMBLY (Pc. No. 17) PROVIDES TEMPERATURE CONTROL, HI-LIMIT, AND LOW WATER SENSING.
 - UNIT IS UL, CUL, AND UL EPH LISTED.
 - PIECE NOS. 5, 10, 20, AND 21 ARE SHIPPED LOOSE.
 - CONTROL CIRCUIT WIRE TO BE #18 TEFZEL 750 (200°C), POWER CIRCUIT WIRE TO BE #10 TEFZEL 750 (200°C). ELEMENT JUMPER WIRE TO BE #12 TEFZEL 750 (200°C).
 - PHASE TO PHASE RESISTANCE: 1.6 OHMS
 - APPROX. WEIGHT:
DRY: 98 LBS.
WET: 146 LBS.

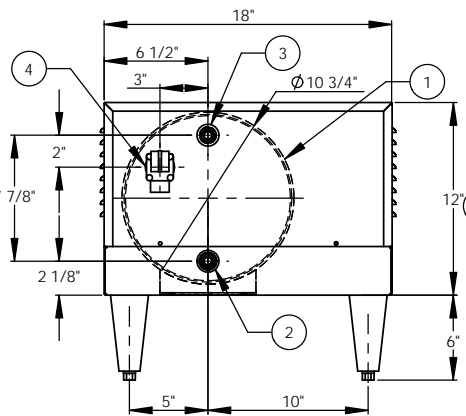

BACK VIEW

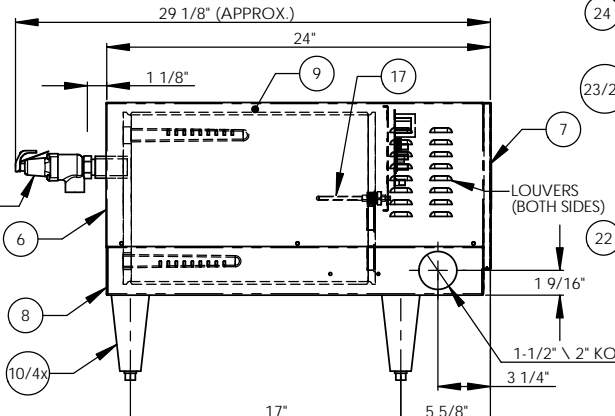

LEFT SIDE VIEW

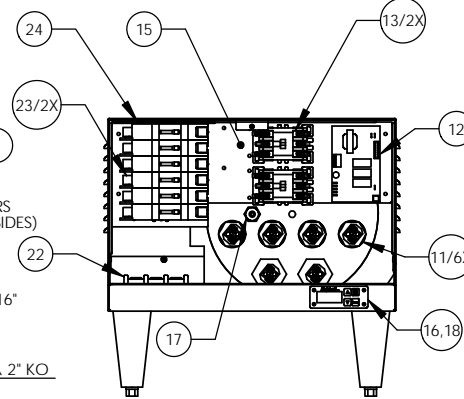

FRONT VIEW
(WITH COVER REMOVED)

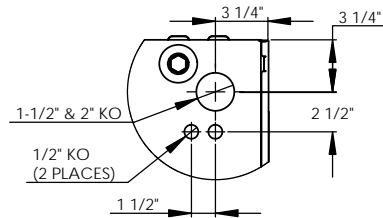
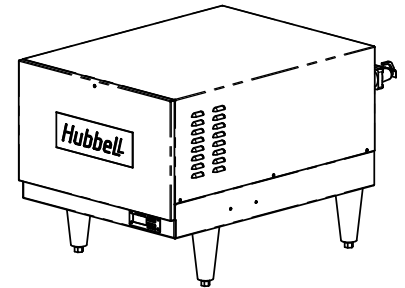

BOTTOM VIEW

INSTALLATION REQUIREMENTS	
AMP Draw	129.8
Min. Breaker/Fuse Size	165 AMP
Cu Power Feed Wire	#2/0 AWG THHN
Min. Power Conduit	1 1/2"
Wiring Diagram	6A

- ELECTRICAL NOTES:
- POWER FEED WIRE SIZING IS BASED ON 75°C Cu THHN WIRE WITH FEEDER BRANCH PROTECTION AT 125%.
 - REFERENCE INSTALLATION, OPERATION, AND MAINTENANCE MANUAL FOR COMPLETE INSTALLATION INSTRUCTIONS.

DATE	NAME	DESCRIPTION
2/26/03	PRD	Stratford, CT 06615 (203) 378-2659
2/26/03	WENIII	The Electric Heater Company
7/10/03	PRD	Customer:
8/29/03	CHD	Description: J MODEL BOOSTER HEATER J627RS - 6 GALLON 27kW - 208V - 1Ø

SIZE	DWG. NO.	REV
C	J627RS	-

SCALE: 1:6	FSCM: 19857	SHEET 1 OF 1
------------	-------------	--------------

PROPRIETARY AND CONFIDENTIAL
THE INFORMATION CONTAINED IN THIS DRAWING IS THE SOLE PROPERTY OF THE ELECTRIC HEATER COMPANY. ANY REPRODUCTION IN PART OR AS A WHOLE WITHOUT THE WRITTEN PERMISSION OF THE ELECTRIC HEATER COMPANY IS PROHIBITED.

DIMENSIONS ARE IN INCHES
TOLERANCES:
(UNLESS OTHERWISE SPECIFIED)
FRACTIONAL: 1/16"
ANGULAR: MACH ±1/2° BEND ±1°
TWO PLACE DECIMAL: ±0.01
THREE PLACE DECIMAL: ±0.005