

C200

USER MANUAL FOR THE METRO C200 SERIES INSULATED HEATED CABINET



InterMetro Industries Corporation
Wilkes-Barre, PA 18705
570-825-2741



TABLE OF CONTENTS

| SECTION | PAGE |
|---|------|
| I. Introduction | |
| A. Identifying Your Cabinet | 1 |
| B. Features | 2 |
| II. Operating Instructions | |
| A. Reversible Doors | 2 |
| B. Slide Rack Assemblies | 2 |
| C. Holding Module | 3 |
| III. Cleaning Instructions | |
| A. Removal of Interior Components | 4 |
| B. Specific Cleaning Instructions | 4 |
| C. General Cleaning Instructions | 4 |
| IV. Maintenance | |
| A. Cabinet Maintenance | 4 |
| B. Module Maintenance | 4 |
| C. Blower Motor Maintenance | 4 |
| V. Repair Parts and Procedures | |
| A. Cabinet | 6 |
| B. Module | 8 |
| Module Replacement Procedure Chart | 10 |
| VI. Wiring Schematic | |
| A. Holding | 12 |

SAMPLE OF CABINET LABELING

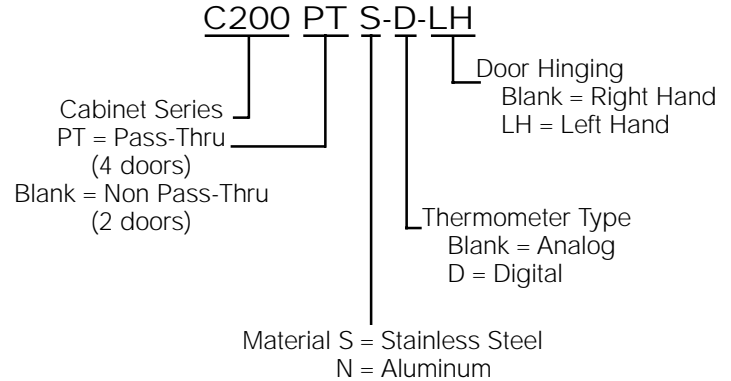

SAMPLE OF SLIDE RACK CARTON LABELING



I. INTRODUCTION

A. IDENTIFYING YOUR CABINET

Your cabinet assembly has been shipped in two cartons. The first carton contains the cabinet with module. The other carton contains the slide racks.

There are three component numbers which you may want to record for future reference: the cabinet model number, the cabinet serial number and the slide rack model number. Refer to the back of the unit to locate the cabinet numbers. The slide rack model number is located on the label affixed to the ends of the rack carton. It is recommended that all numbers be recorded in an appropriate place, such as at the bottom of this page. Also, please record the cabinet model number and module serial number on the Warranty Card found at the back of this manual. Be sure to complete the remainder of the Warranty Card and return it to Metro within fifteen (15) days of delivery of the cabinet. Once you have located and recorded these numbers, refer to the sample numbers given to identify the components of your C200 series cabinet.

NOTE: Peel off any protective covering from the exterior of the cabinet. Covering must be removed before placing the cabinet into service.

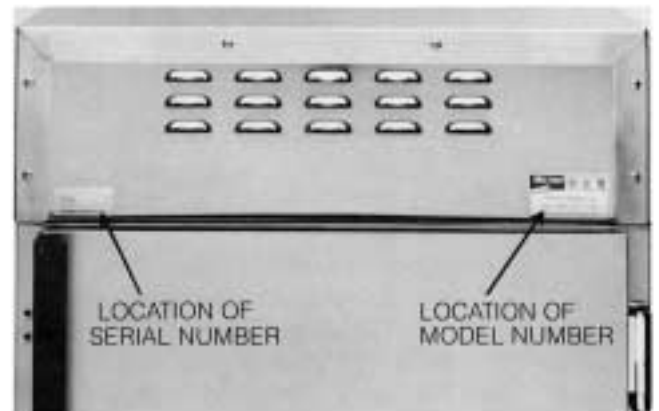

NOTE: Please read this manual thoroughly before using your cabinet. If you should have questions, please contact Metro customer service department.

B. FEATURES — ALL MODELS

In order to utilize your new cabinet to its full potential, take a minute to identify the following features which have been provided for your convenience.

- The module has been placed at the top of the cabinet for easy accessibility and efficient operation.
- Clearly-marked control panel angled for easy viewing and climate adjustments without opening the door.
- Removable water pan.
- Dutch-style insulated and gasketed doors.
- Heavy-duty magnetic door latches.
- All components — doors, module, chimneys, slide racks — removable without tools to permit thorough, obstruction-free cleaning.

II. OPERATING INSTRUCTIONS

A. REVERSIBLE DOOR(S)

NOTE: Only the doors on the Non Pass-Thru Models are field reversible. The doors on your Non Pass-Thru Cabinet can be reversed to accommodate a right- or left-hand opening. The cabinet has been shipped with the hinges mounted on the right-hand side of the unit. To reverse, follow the instructions listed below:

1. If the cabinet was in operation, allow sufficient time for it to cool down to comfortable level. Unlatch the doors, swing open and lift vertically until clear of cabinet mounted hinges. Place doors aside.
2. On the cabinet, remove the door strike plates and hinges. Transfer them to the opposite side of the cabinet. Install filler screws in the original hinge and plate holes.
3. On the doors, remove the round covers from the hinges. Also remove the screws securing the hinges to the doors.
4. Rotate the hinges 180 degrees and reassemble.
5. On the cabinet mounted hinges, lift the white bushing vertically and rotate 180 degrees, then seat.
6. Take the top door, rotate 180 degrees and drop it onto the bottom cabinet mounted hinges. Take the other door and drop it onto the top mounted cabinet hinges.
7. Test doors to make sure gaskets are in compression and the door latches hold securely.

B. SLIDE RACK ASSEMBLIES

All models of slide racks are removable for thorough cleaning.

On the inside of each cabinet are a series of rack hangers. These hangers have two slots for either an inboard or outboard rack position. To remove the slide rack, grasp and move upward until pins are free of hanger slots. To install racks, locate pins over hangers and lower until locked into the slots.

NOTE: For an inboard rack position, use the slots farthest away from the inside wall of the cabinet. For an outboard rack position, use the slots closest to the inside wall of the cabinet.

C4SC — Model 4 (3" Slide Spacing — fixed)

The Model 4 Slide Rack consists of two sets of slides. Both sets can be installed either in an inboard or an outboard position. Also, one set of racks can be placed in the inboard position while the second set can be installed in the outboard position. All pans are to be bottom loaded regardless of rack positioning. The following pans may be used:

Inboard Hanger Position (18" width)

17 pans — 18"x27"x2⁵/₈"
17 pans — 14"x18"x2⁵/₈"
Max. pan size: 18"x27"x2⁵/₈"
Min. pan size: 17"

Outboard Hanger Position (20" width)

17 pans — 20"x24"x2¹/₄"
17 pans — 20"x24"x2⁵/₈"
34 pans — 12"x20"x2¹/₄"
34 pans — 12"x20"x2⁵/₈"
Max. pan size: 20"x27"x2⁵/₈"
Min. pan size: 19"

2C8SN—Model 28 (1¹/₂" Spacing — fixed)

The Model 28 Slide Rack can only be installed in the inboard hanger position. All pans are to be lip loaded. The following pans may be used: 34 pans — 18"x26" max. height 1³/₈". Max. pan size: 18"x27"x1³/₈"
Min. pan size: 18"

2CVSN—Model 2V (adjustable)

The Model 2V Slide Rack can be installed in either an inboard or outboard position. Center spacing on slides can be either 3" or 4¹/₂". Slides can be removed by lifting upward and sliding rivet heads out of the keyhole slots. To install, select spacing, insert rivet heads into keyhole slots and push down until locked in hole. All pans are to be bottom loaded regardless of slide or rack positioning.

With the racks in the inboard position (18" width), the following pans may be used:

3" Slide Spacing

16 pans — 18"x26"x2⁵/₈"
32 pans — 12"x18"x2⁵/₈"
32 pans — 13"x18"x2⁵/₈"
17 pans — 14"x18"x2⁵/₈"
Max. or combined pan size: 18"x27"x2⁵/₈"
Min. pan width: 16"

4¹/₂" Slide Spacing

11 pans — 18"x26"x4¹/₈"
22 pans — 12"x18"x4¹/₈"
22 pans — 13"x18"x4¹/₈"
22 pans — 14"x18"x4¹/₈"
Max. or combined pan size: 18"x27"x4¹/₈"
Min. pan width: 18"

With the racks in the outboard position (20" width), the following pans may be used:

3" Slide Spacing

17 pans — 15"x20"x2⁵/₈"
34 pans — 10⁷/₈"x19³/₄"x2⁵/₈"
34 pans — 11¹/₈"x20"x2⁵/₈"
17 pans — 20"x20"x2⁵/₈"
16 pans — 20"x22"x2⁵/₈"
32 pans — 12"x20"x2⁵/₈"
17 pans — 20"x24"x2⁵/₈"
Max. or combined pan size: 20"x27"x2⁵/₈"
Min. pan width: 16"

4¹/₂" Slide Spacing

11 pans — 15"x20"x4¹/₈"
22 pans — 10⁷/₈"x19³/₄"x4¹/₈"
22 pans — 11¹/₈"x20"x4¹/₈"
11 pans — 20"x20"x4¹/₈"
11 pans — 20"x22"x4¹/₈"
22 pans — 12"x20"x4¹/₈"
11 pans — 20"x24"x4¹/₈"
Max. or combined pan size: 20"x27"x4¹/₈"
Min. pan width: 18"

C. HOLDING MODULE

Equipped with a holding module, your **cabinet is designed to maintain the temperature of HOT prepared foods**. The holding module is equipped with a thermostatically controlled heater, a blower for air circulation and a water pan. A POWER switch is provided with a red light to indicate when the unit is switched ON. A TEMPERATURE thermostat and its yellow indicator light are also provided along with a thermometer.

A three-wire grounded lead cord is supplied fixed to the module.

1. With POWER switch OFF, plug lead cord into a standard grounded 20-amp, 125-VAC receptacle.

2. To introduce limited humidity, fill the 1¹/₂-quart capacity water pan to ¹/₂" from top with HOT clean tap water. During operation, check water level every 3 hours and refill as necessary. The unit may be operated without water if humidity is not desired.

Above the water pan is an adjustable vent. By rotating the vent open even more humidity can be introduced into the cabinet.

3. Snap POWER switch to ON. The red light will now glow as will the yellow indicator light, and the blower will begin circulating air.
4. Turn the TEMPERATURE thermostat to setting 10.
5. After allowing the cabinet to PREHEAT FOR APPROXIMATELY 45 MINUTES, reduce the thermostat setting to 8. In a room of average temperature (72°F), this should provide 150°-170°F. Adjustments to the temperature may be made as necessary.

NOTE: The red light will glow as soon as the POWER switch is switched ON and will continue to glow until switched OFF. The yellow indicator light will go on and off as the thermostat cycles the heat element. The blower will operate as long as the POWER switch is ON. If the yellow light is not illuminated, this indicates that the cabinet has achieved the preset TEMPERATURE level, NOT that the unit has been switched OFF.

It is not necessary at the end of the operating day to disrupt the TEMPERATURE setting in order to turn the unit OFF. By switching the POWER switch to OFF, the unit is no longer operating. By switching the POWER switch to ON when resuming operations, the cabinet will attain the preset level.

III. CLEANING INSTRUCTIONS

ALL MODELS

Your C200 series cabinet has been listed by the National Sanitation Foundation (NSF) which means that it has been designed and constructed in a way that promotes a sanitary condition, i.e. sanitary materials and easy cleanability. To maintain a sanitary condition and obtain the best cabinet performance, Metro strongly suggests that the cabinet be thoroughly cleaned on a regular basis—daily if necessary.

CAUTION

AT NO TIME SHOULD THE MODULE OR CABINET BE WASHED OR FLOODED WITH WATER OR LIQUID SOLUTION. NEVER STEAM CLEAN. SEVERE DAMAGE OR ELECTRICAL HAZARD COULD RESULT.

1. Turn off master switch.
2. Disconnect the unit from its power source.

WARNING

ALLOW THE UNIT TO COOL BEFORE CLEANING, AS THE INTERIOR OF THE CABINET MAY BE HOT ENOUGH TO BURN. ALSO ALLOW THE WATER IN THE PAN TO COOL BEFORE REMOVAL.

3. Open the door(s) and remove the slide racks and chimney.
4. If there is water in the pan, remove the pan from the cabinet and empty the water.
5. Remove the thumb screw securing each chimney in place. Rotate each chimney away from the cabinet wall and remove from unit.
6. To remove the module, eight thumb screws must be removed from the ceiling of the cabinet. First remove the water pan. Separate the pan holder from the unit by removing the four thumb screws.
7. At each corner of the cabinet ceiling remove the four thumb screws.
8. Lift the module from the cabinet and place on a flat surface.
9. **NOTE:** Do not use abrasive cleaners. For every cleaning method, best results are always obtained when the cleaner and technique are matched to the soil conditions involved. Contact your detergent representative to ensure the cleaning product being used is recommended for use on natural and epoxy coated aluminum and stainless steel. Follow the manufacturer's directions on cleaners. Never mix cleaners.
10. After cleaning, replace all components. Make sure the slide racks and chimney are seated in the hangers correctly.

A. SPECIFIC CLEANING INSTRUCTIONS

1. Do not immerse the module when cleaning. Instead, use a damp cloth and a drying towel. Special attention should be paid to keeping the air-inlet area and the controls area free of dirt build-up. **BE SURE TO THOROUGHLY DRY THE MODULE BEFORE RETURNING IT TO USE.**

B. GENERAL CLEANING INSTRUCTIONS

1. **LIGHT SOIL**
If routine (daily) cleaning is practiced, a mild soap and warm water should be sufficient to keep the unit clean.
2. **HEAVIER SOIL**
If cleaning has been postponed, solvent or emulsion type cleaners that can be applied with bare hands will give excellent results. Such cleaners are available under various brand names and detergent suppliers can recommend materials appropriate for use on natural and epoxy-coated aluminum and stainless steel.

VI. MAINTENANCE

A. CABINET MAINTENANCE — ALL MODELS

Your C200 series cabinet has been designed to require very little maintenance. With normal use, cleaning is the only form of maintenance that need be done on a regular basis. Keeping the casters free of dirt build-up will go a long way in prolonging their life.

If your cabinet is rolled over rough surfaces or transported over-the-road, the various threaded fasteners, i.e., screws and nuts, should be periodically inspected and tightened if necessary.

B. MODULE MAINTENANCE

The module in the top of your cabinet has also been designed to require very little maintenance. With normal use, cleaning is the only form of maintenance that need be done on a regular basis. Keeping vital areas such as the air-inlet area and the controls area free of dirt build-up will go a long way in prolonging the life of the electrical components. No maintenance is required on the electrical components.

V. REPLACEMENT PARTS AND PROCEDURES

A. CABINET — ALL MODELS

1. Refer to the Cabinet Replacement Parts Diagram below to identify the replacement parts.
2. Refer to the Cabinet Replacement Procedure Chart on page 6 for replacement instructions.

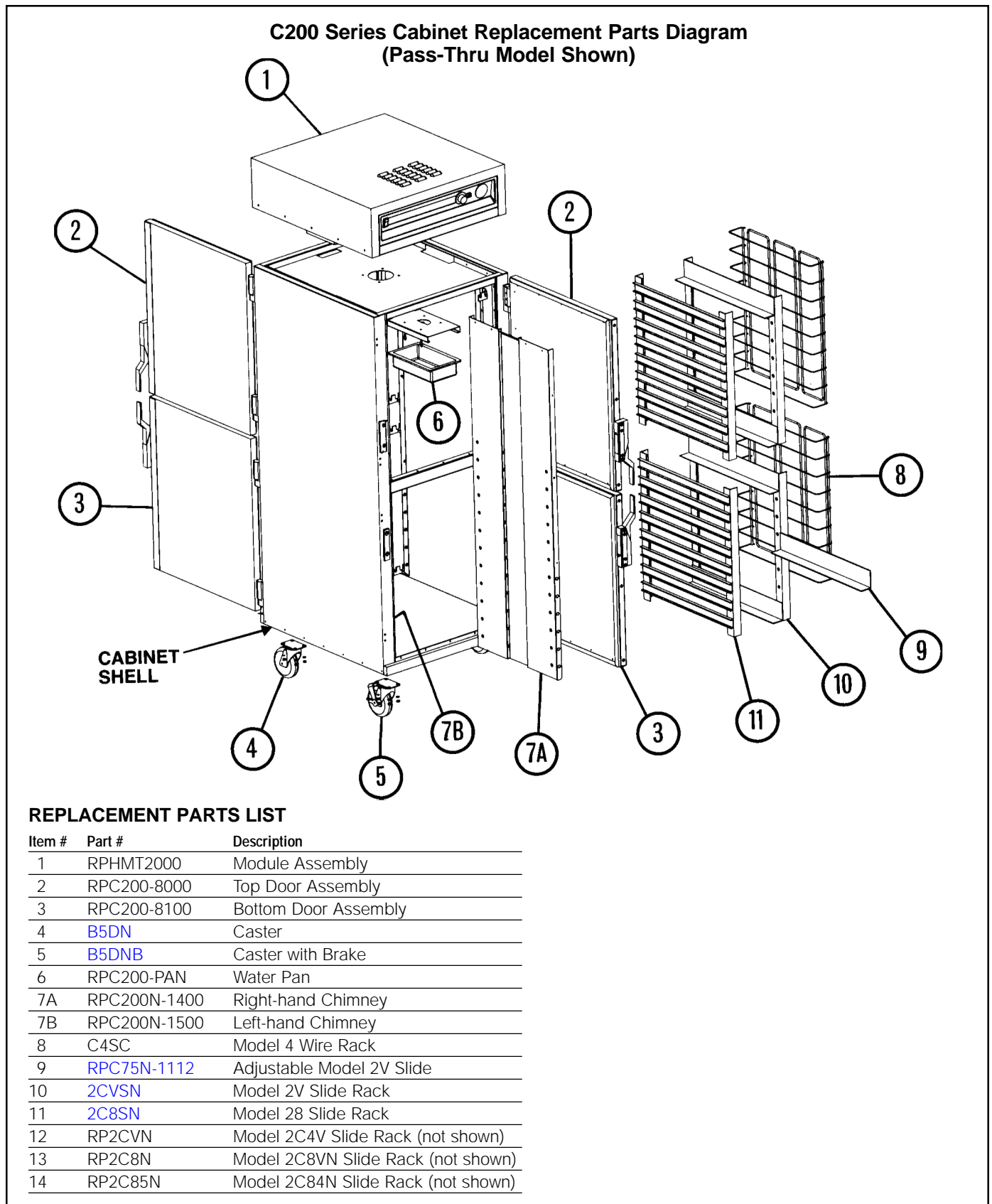

C200 SERIES CABINET REPLACEMENT PROCEDURE CHART (Pass-Thru Model Shown)

| PART TO BE REPLACED | REPLACEMENT PROCEDURE |
|--------------------------------|---|
| 1. Module Assembly | For a stainless steel module using an analog thermometer, replace with part number RPHMT2000. For a stainless steel module using a digital thermometer, replace with part number RPHMT2000D. For an aluminum module using an analog thermometer, replace with part number RPHMT2000N. For an aluminum module using a digital thermometer, replace with part number RPHMT2000ND. 1. See page 8, Section B, Step #1 for module replacement procedure. |
| 2. Top Door Assembly | For right-hand hinging stainless steel door, replace with part number RPC200-8000; for left-hand hinging stainless steel door, replace with part number RPC200LH-8000. For right-hand hinging aluminum door, replace with part number RPC200N-8000. For a left-hand hinging aluminum door, replace with part number RPC200NLH-8000. 1. Lift the door up off the hinges. 2. Position door and drop door hinge down on cabinet hinge. |
| 3. Bottom Door Assembly | 1. For right-hand hinging stainless steel door; replace with part number RPC200-8100; for left-hand stainless steel, replace with part number RPC200LH-8100. For right-hand hinging aluminum door, replace with part number RPC200N-8100. For left-hand hinging aluminum door, replace with part number RPC200NLH-8100. |
| 4. Swivel Caster | Replace with part number B5DN . 1. Follow instructions for item 5, caster with brake. |
| 5. Caster with Brake | Replace with part number B5DNB . 1. Lay cabinet on its side. 2. Remove hardware holding caster to chassis. 3. Replace with new caster and assemble with hardware. |
| 6. Water Pan | Replace with part number RPC200-PAN. |
| 7. Chimneys | 2 per unit. Replace with part numbers: Right-hand chimney RPC200N-1400; Left-hand chimney RPC200N-1500. 1. Remove thumb screw holding chimney in place. 2. Remove chimney. 3. Replace with new chimney. 4. Secure with thumb screw. |

| PART TO BE REPLACED | REPLACEMENT PROCEDURE |
|-------------------------------------|--|
| 8. Model C4SC Slide Rack | Replace with part number C4SC (consists of 1 pair of racks — 2 pair can be used in unit) |
| 9. Adjustable Model 2V Slide | 1. To replace or add the adjustable slide, order part number RPC75N-1112 . |
| 10. Model 2CVSN Slide Rack | Replace with part number 2CVSN (consists of 2 pair slides and 10 pair of adjustable slides) 1. Lift racks up off of hangers 2. Install new racks |
| 11. Model 2C8N Slide Rack | Replace with part number 2C8SN (consists of 2 pair slides). 1. Lift racks up off of hangers. 2. Install new racks. |
| 12. Model 2C4V Slide Rack | Replace aluminum racks with 1 pair of RP2CVN slides and wire racks with part number RPC4SL-SING. Follow instructions listed above for other slide racks. |
| 13. Model 2C8VN Slide Rack | Replace fixed rack with 1 pair RP2C8N. Replace adjustable racks with 1 pair of part number RP2CVN. |
| 14. Model 2C84N Slide Rack | Replace aluminum slides with part number RP2C85N (1 pair) and wire racks with RP2C8SN (1 pair). |

C200 Series Door Replacement Parts Diagram

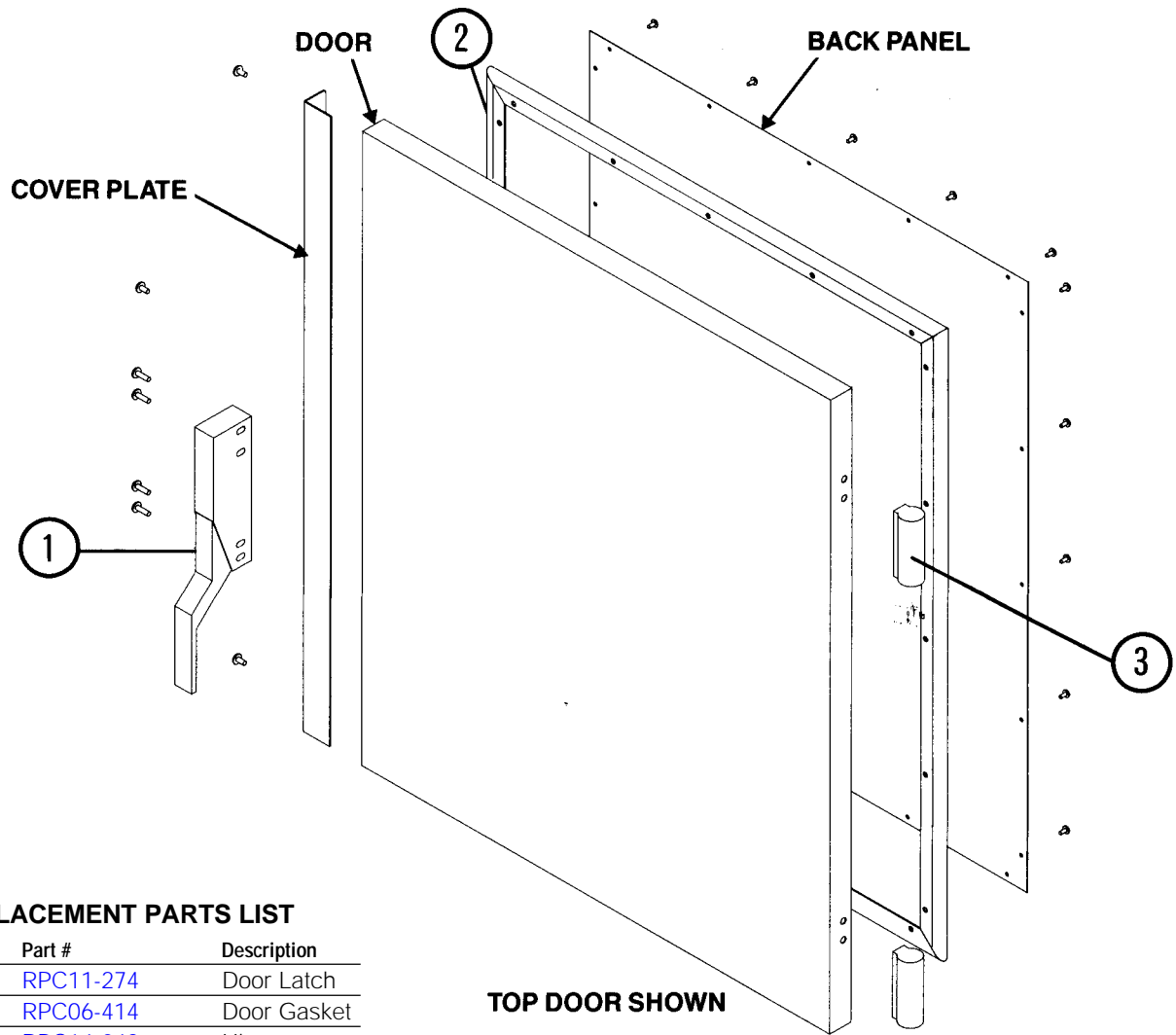

REPLACEMENT PARTS LIST

| Item # | Part # | Description |
|--------|---------------------------|-------------|
| 1 | RPC11-274 | Door Latch |
| 2 | RPC06-414 | Door Gasket |
| 3 | RPC14-042 | Hinge |

C200 SERIES DOOR REPLACEMENT PROCEDURE CHART

| PART TO BE REPLACED | REPLACEMENT PROCEDURE |
|-----------------------|---|
| 1. Door Latch | <ol style="list-style-type: none"> 1. Remove screws securing latch to door. 2. Replace with part number RPC11-274. |
| 2. Door Gasket | <p>Replace with part number RPC06-414.</p> <ol style="list-style-type: none"> 1. Remove door from unit. Remove screws securing inner door panel and gasket. 2. Lift panel and gasket from door. 3. Position new gasket and inner panel back on door. 4. Secure with hardware. 5. Mount door back on cabinet. |

| PART TO BE REPLACED | REPLACEMENT PROCEDURE |
|-----------------------|---|
| 3. Door Hinges | <p>Replace with part number RPC14-042.</p> <ol style="list-style-type: none"> 1. The replacement is supplied in two parts; the lower portion mounts to the cabinet; the upper portion mounts to the door. 2. To replace the cabinet hinge section, remove screws and secure new hinge section. 3. To replace the door hinge section, remove the hinge cap from the body. Remove screws. 4. Pop cap from new hinge section. Attach hinge to door. Install cap. |

NOTE: When hinges are replaced on left-hand hinging door, the white nylon bushing must be rotated for the self-closing feature. See Section II A, Step No. 5.

B. MODULE

Your module has been designed to be user-serviceable, assuming a basic knowledge of the operation of electrical devices. This section has been written to guide the user step by step, and in layman's terms, through the dismantling and servicing of the module. Before attempting to service your module, read the appropriate Module Repair Procedures (found elsewhere in this section) thoroughly. If you do not understand the Repair Procedures or prefer not to service your module yourself, or if your warranty is still in effect, please contact our Customer Service Department for the factory authorized service agency nearest you.

CAUTION: IT IS IMPORTANT THAT ALL SAFETY PRECAUTIONS PERTAINING TO THE SERVICING OF ELECTRICAL DEVICES BE OBSERVED AT ALL TIMES.

1. Dismantle your module for servicing per the following instructions.

NOTE: To replace the Thermostat Knob, it is not necessary to dismantle the module.

- a. Make sure the power cord is not plugged into an outlet. Be certain that the module and any water in the water pan has cooled to a temperature safe for handling.
 - b. To remove the module, eight thumb screws must be removed from the ceiling of the cabinet. First remove the water pan. Separate the pan holder from the unit by removing the four thumb screws.
 - c. At each corner of the cabinet ceiling remove the retaining four thumb screws.
 - d. Lift the module from the cabinet and place on a flat surface.
 - e. Unfasten the electrical cover by removing the screws along the bottom sides and rear of the module. Retain this hardware for re-assembly.
 - f. Lift the cover up off the module. Thread cord through bushing. **IF NECESSARY TO RECONNECT THE OPENED MODULE TO A POWER SOURCE, PRACTICE EXTREME CAUTION SO AS NOT TO RECEIVE ELECTRICAL SHOCK FROM EXPOSED COMPONENTS.**
2. Refer to the appropriate Module Replacement Parts Diagram to identify the internal components. Determine malfunctioning component(s) by electrical diagnostic procedures.
3. Refer to the appropriate column of the Module Replacement Procedures Chart on pages 10 and 11 for replacement instructions.

4. After servicing, be sure to verify the routing of each wire with the appropriate wiring schematic before installing electrical cover and connecting module to power source. Be sure that the thermostat sensor tube does not contact any electrical connections.
5. Assemble components using retained hardware, making sure that no wires are pinched between the cover and the module platform.

C200 Module Replacement Parts Diagram

The power cord, snap bushing, terminal block, master switch, thermostat knob and strain relief bushing can be serviced without removing the module assembly from the cabinet. The module cover must be removed to gain access to internal parts. The thermostat, thermometer, blower heating element and hi-temperature switch must be serviced with the module separated from the cabinet.

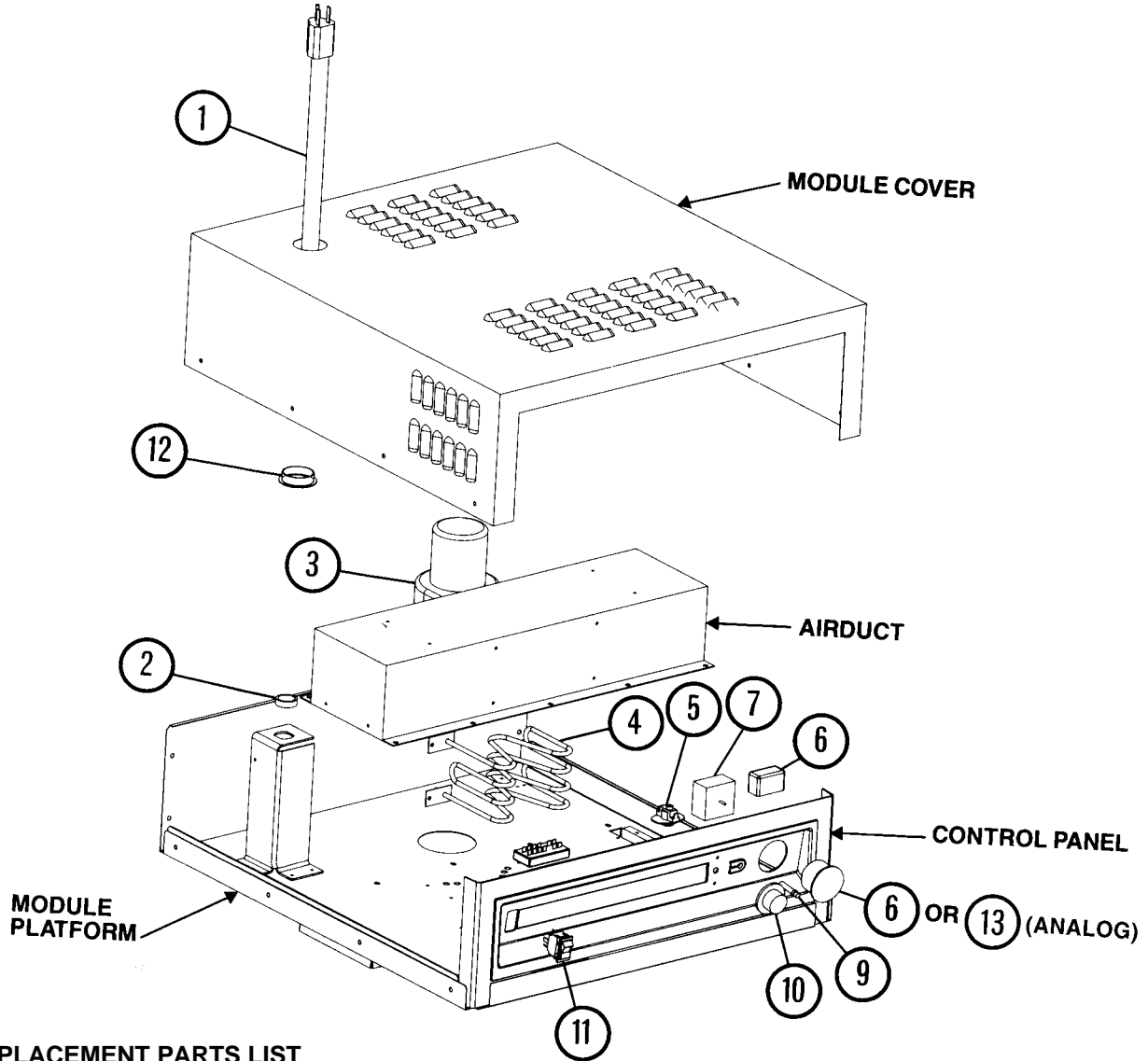

REPLACEMENT PARTS LIST

| Item # | Part # | Description |
|--------|---|--|
| 1 | RPCORD-20A | Power Cord |
| 2 | RPC13-098 | Strain Relief Bushing |
| 3 | RPHM20-2103 | Blower Assembly |
| 4 | RPC13-126 | Heating Element |
| 5 | RPC13-134 | Hi-Temperature Switch |
| 6 | RPC13-181 & RPC13-183 | Transformer & Thermometer (Digital Models) |
| 7 | RPC13-135 | Thermostat |
| 8 | RPC13-096 | Terminal Block |
| 9 | RPC13-105 | Indicator Light — Yellow |
| 10 | RPC06-313 | Thermostat Knob |
| 11 | RPC13-132 | Master Switch |
| 12 | RPC13-106 | Snap Bushing |
| 13 | RPC13-139 | Thermometer (Analog) |

VI. WIRING SCHEMATICS

C200 Module Wiring Diagram

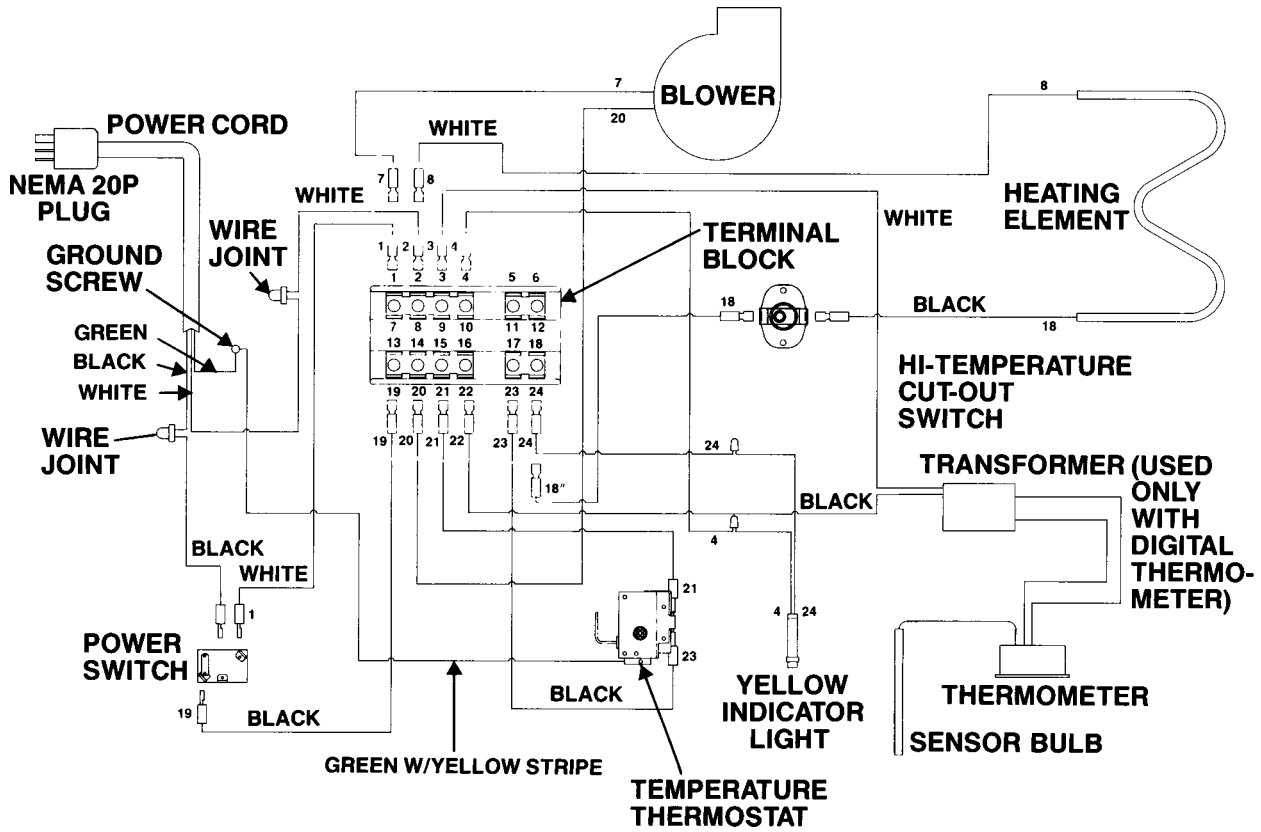

Thank you for purchasing a Metro Mobile Heated Cabinet. We are certain you will be more than satisfied with its quality and performance. Please fill in the warranty information space below so we may register your warranty. Also, so that we may learn more about our customers and hopefully be of continued service in the future, please take a moment to fill in the customer information space below.

Thank You

CUT ALONG DOTTED LINE

CUSTOMER INFORMATION

1. Which one of the following best describes your establishment?

- a. Full Service Restaurant
- b. Fast Food Restaurant
- c. Hotel/Motel
- d. Hospital/Nursing Home
- e. College/University
- f. School
- g. Employee Feeding
- h. Other _____

WARRANTY INFORMATION:

Cabinet Model No. _____
Module Serial No. _____
Slide Rack Model No. _____
Date Purchased _____
Customer Name _____
Address _____

Phone No. _____

For warranty coverage, this card must be returned to Metro.

FOLD HERE — DO NOT DETACH

2. Please indicate the two product benefits that were of major interest to you.

- a. Accessibility to controls without opening door.
- b. All components within cabinet removable for cleaning.
- c. Better control of conditions in cabinet.
- d. Uniform environment within cabinet due to forced air circulation, chimney design and gasketed doors.
- e. Reversible doors. (Non-Pass Thru)
- f. Aesthetic quality (styling).
- g. Other (in addition to above two) _____

3. Main factor that led to your decision to purchase this product?

- a. Product operating and functional features
- b. Overall quality
- c. Price
- d. Availability
- e. Other _____

4. Three sources that led to the purchase of this product — in the order of their impact (1 - being most impact; 3 - being least impact).

- a. Trade Journal Ad
- b. Trade Show
- c. Sales Call
- d. Direct Mail
- e. Previous Purchase
- f. Other _____

CUT ALONG DOTTED LINE



WILKES-BARRE PA 18705-9968

P O BOX A

ATTN: CUSTOMER SERVICE

INTERMETRO INDUSTRIES CORPORATION

POSTAGE WILL BE PAID BY

BUSINESS REPLY MAIL
FIRST-CLASS PERMIT NO. 121 WILKES-BARRE, PA

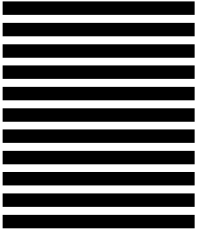

NO POSTAGE
NECESSARY
IF MAILED
IN THE
UNITED STATES

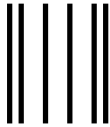

FOLD HERE — DO NOT DETACH

STAPLE HERE

STAPLE HERE

STAPLE HERE

Warranty

WARRANTY, EXCLUSION OF WARRANTIES AND LIMITATION OF LIABILITY.

InterMetro Industries Corporation (hereinafter referred to as "Seller") warrants to the original purchaser that all products in its catalog, or custom products, delivered hereunder will be free from defects in workmanship and material. **THE FOREGOING WARRANTY IS EXCLUSIVE AND IN LIEU OF ALL OTHER WARRANTIES, EXPRESS, IMPLIED OR STATUTORY, INCLUDING ANY WARRANTY OF MERCHANTABILITY OR FITNESS FOR A PARTICULAR PURPOSE.** This Warranty shall be for a period of one (1) year from the date of shipment from Seller's warehouse or factory. If any product delivered hereunder does not meet the Warranty specified above, providing the product has not been altered in any way by anyone other than Seller's factory-authorized representative, and assuming normal and proper use and maintenance, Seller will, at its option, repair or replace any part or material it determines, upon inspection, to be defective; provided however, that a charge for labor will be made except during a period of one (1) year from the date of original shipment from Seller's warehouse or factory. No product, or part thereof, is to be returned to Seller without prior written approval from Seller's factory. All exchanges and replacement shipments will be F.O.B. Seller's factory. Warranties for equipment or articles not manufactured by the Seller are solely the warranties of the manufacturers thereof and they are hereby assigned to the purchaser without recourse to the Seller.

SELLER'S LIABILITY FOR ANY CLAIM OF ANY KIND, WHETHER BASED ON CONTRACT, NEGLIGENCE OR STRICT LIABILITY IN TORT, AND BY WHOMEVER MADE, FOR ANY DIRECT, INDIRECT, INCIDENTAL OR CONSEQUENTIAL LOSS, DAMAGE OR INJURY, RESULTING TO THE PURCHASER OR ANY THIRD PARTIES, arising out of, connected with or resulting from this Agreement, or from the performance or breach thereof, or from the manufacture, sale, delivery, resale, installation, inspection, repair or use of any product covered by or furnished under this Agreement, WHETHER OR NOT CAUSED BY SELLER'S NEGLIGENCE, SHALL IN ALL EVENTS BE EXCLUSIVELY LIMITED TO THE COST OF CORRECTING DEFECTIVE, DAMAGED OR NON-CONFORMING PARTS OR MATERIAL AS HEREIN PROVIDED, and upon the expiration of one (1) year, all such liability shall terminate.

SELLER DOES NOT AUTHORIZE any person to assume for it any obligations or liabilities greater than or different than those set forth in this Warranty. The terms under which any of Seller's products may be resold must be limited in accordance with this Warranty.

THIS AGREEMENT, and all the rights and obligations arising hereunder, shall be construed in accordance with, and be governed by, the law of the Commonwealth of Pennsylvania, U.S.A.

TO INSURE WARRANTY implementation, return the completed registration card within 15 days of cabinets' receipt to: InterMetro Industries Corp., Wilkes-Barre, PA 18705



InterMetro Industries Corporation
Wilkes-Barre, PA 18705



InterMetro Industries Corporation

North Washington Street, Wilkes-Barre, PA 18705

For Product Information Call: 1-800-433-2232

Visit Our Web Site: www.metro.com

L01-182

Rev. D 4/03

Information and specifications are subject to change without notice. Please confirm at time of order.