

Jackson[®]

WAREWASHING SYSTEMS

INSTALLATION, OPERATION, AND SERVICE MANUAL



RACKSTAR SERIES CONVEYOR DISHMACHINES

RackStar Manual • 07610-005-17-71-A

RACKSTAR[®]

**MANUFACTURER'S LIMITED WARRANTY
(APPLICABLE ONLY IN THE UNITED STATES AND CANADA)**

WARRANTY REGISTRATION:

To register your Jackson Dishmachine's warranty go to jacksonwws.com/warranty or call 1-888-800-5672. Failure to register the Dishmachine will void the warranty.

ONE YEAR LIMITED PARTS AND LABOR WARRANTY

For a period of one (1) year from date of original installation of a new Jackson Dishmachine (but in no event to exceed eighteen (18) months from date of shipment from Jackson's factory), Jackson WWS, Inc. (Jackson) will repair or replace, at its discretion, any original part that proves defective in materials or workmanship at the time the Dishmachine was purchased; provided that (i) the Dishmachine has not been altered, (ii) the Dishmachine has been properly installed, maintained, and operated under normal use conditions and in accordance with the applicable installation, operation and service manual available on the Jackson website, and (iii) a warranty claim is reported to a Jackson Authorized Service Agency within the warranty period. This warranty includes replacement with Jackson specified genuine replacement parts, purchased directly from a Jackson Authorized Parts Distributor or Service Agency. Use of generic replacement parts may create a hazard and shall void this warranty.

THIS WARRANTY DOES NOT APPLY OUTSIDE THE UNITED STATES AND CANADA.

Jackson will pay the labor to repair or replace a defective original part as a part of the warranty, provided that a Jackson Authorized Service Agency performs the labor. Any repair or replacement work by anyone other than a Jackson Authorized Service Agency is the sole responsibility of the purchaser. Labor coverage is limited to regular hourly rates; Jackson will not pay overtime premiums or emergency service charges.

Accessory components (such as table limit switches, pressure regulators, and drain water tempering kits) that are not installed by Jackson at the factory and are shipped with the Dishmachine carry only a (1) one-year parts warranty. Labor to repair or replace these components is not included in the warranty or covered by Jackson. Booster heaters not manufactured by Jackson are not covered by this warranty but are warranted by their respective manufacturers.

This warranty is void if any defect or failure is a direct result from shipping, handling, fire, water, accident, alteration, modification, misuse, abuse, flood, acts of God, burglary, casualty, attempted repair by unauthorized persons, use of replacement parts not authorized by Jackson, improper installation, installation not in accordance with local electrical and plumbing codes, if the serial number has been removed or altered, if the Dishmachine is used for any purpose other than originally intended, or if the equipment is installed for residential use.

Jackson does not authorize any other entity or person, including, without limitation, any entity or person who deals in Jackson Dishmachines, to change this warranty or create any other obligation in connection with Jackson Dishmachines.

TRAVEL LIMITATIONS:

Jackson limits warranty travel time to the customer site within 50 miles of the Jackson authorized service agent's office and during regular business hours. Jackson will not pay for travel time and mileage that exceeds these limits, or any fees such as those for air or boat travel without prior authorization.

REPLACEMENT PARTS WARRANTY:

For a period of (90) ninety days from the date of installation by a Jackson Authorized Service Agency (but in no event to exceed (180) one-hundred-eighty days from the date of purchase from a Jackson Authorized Parts Distributor or Service Agency), Jackson will repair or replace, at its discretion, any Jackson genuine replacement parts that prove defective in materials or workmanship at the time the replacement parts were installed. This warranty does not include paying the labor to repair or replace the replacement part. This warranty is subject to all conditions, exclusions and limitations applicable to the Dishmachine.

**MANUFACTURER'S LIMITED WARRANTY (CONT.)
(APPLICABLE ONLY IN THE UNITED STATES AND CANADA)**

PRODUCT CHANGES:

Jackson reserves the right to make changes in design and specification of any component of the Dishmachine as engineering or necessity requires.

DISCLAIMER OF WARRANTIES:

THERE ARE NO WARRANTIES, EXPRESSED OR IMPLIED, INCLUDING, WITHOUT LIMITATION, ANY IMPLIED WARRANTY OF FITNESS FOR A PARTICULAR PURPOSE OR MERCHANTABILITY, THAT ARE NOT SET FORTH HEREIN, OR THAT EXTEND BEYOND THE DURATION HEREOF.

LIMITATION OF REMEDIES AND LIABILITIES:

YOUR SOLE AND EXCLUSIVE REMEDY UNDER THIS LIMITED WARRANTY SHALL BE PRODUCT REPAIR OR REPLACEMENT AS PROVIDED HEREIN.

UNDER NO CIRCUMSTANCES WILL JACKSON BE LIABLE FOR ANY INCIDENTAL OR CONSEQUENTIAL DAMAGES, OR FOR DAMAGES IN THE NATURE OF PENALTIES. JACKSON'S LIABILITY ON ANY CLAIM OF ANY KIND WITH RESPECT TO THE GOODS OR SERVICES COVERED HEREUNDER SHALL IN NO CASE EXCEED THE PRICE OF THE GOODS OR SERVICES OR PART THEREOF WHICH GIVES RISE TO THE CLAIM.

ITEMS NOT COVERED:

THIS WARRANTY DOES NOT COVER (1) ADJUSTMENTS INCLUDING, BUT NOT LIMITED TO, TIMER CAMS, THERMOSTATS, DOORS, TANK HEATER ADJUSTMENTS OR CLUTCHES; (2) AIR FREIGHT OR OVERNIGHT FREIGHT; (3) ANY AMOUNT EXCEEDING ORIGINAL PURCHASE PRICE; (4) CLEANING OF DRAIN VALVES, GAS LINES, RINSE/WASH NOZZLES, STRAINERS, SCREENS, OR SPRAY PIPES; (5) CLEANING OR DELIMING OF THE DISHMACHINE OR ANY COMPONENT INCLUDING, BUT NOT LIMITED TO, WASH ARMS, RINSE ARMS AND STRAINERS; (6) CONDITIONS CAUSED BY THE USE OF INCORRECT (NON-COMMERCIAL) GRADE DETERGENTS; (7) CORROSION FROM CHEMICALS DISPENSED IN EXCESS OF RECOMMENDED CONCENTRATIONS; (8) COSMETIC DAMAGE, INCLUDING BUT NOT LIMITED TO, SCRATCHES, DENTS, CHIPS, AND OTHER DAMAGE TO THE DISHMACHINE FINISHES, UNLESS SUCH DAMAGE RESULTS FROM DEFECTS IN MATERIALS AND WORKMANSHIP AND IS REPORTED TO JACKSON WITHIN (30) THIRTY DAYS FROM THE DATE OF INSTALLATION; (9) DAMAGE CAUSED BY LABOR DISPUTE; (10) DAMAGES RESULTING FROM IMPROPER CONNECTION TO UTILITY SERVICE; (11) DAMAGES RESULTING FROM WATER CONDITIONS, INADEQUATE OR EXCESSIVE WATER PRESSURE, ACCIDENTS, ALTERATIONS, IMPROPER USE, ABUSE, HANDLING, OVERLOADS, TAMPERING, IMPROPER INSTALLATION OR FAILURE TO FOLLOW MAINTENANCE AND OPERATING PROCEDURES; (12) DISCOLORATION, RUST OR OXIDATION OF SURFACES RESULTING FROM CAUSTIC OR CORROSIVE ENVIRONMENTS, INCLUDING, BUT NOT LIMITED TO, HIGH SALT CONCENTRATIONS, HIGH MOISTURE OR HUMIDITY, OR EXPOSURE TO CHEMICALS; (13) ELECTRIC BOOSTERS, FEED LINES, FLEX HOSE, FUSES, GARBAGE DISPOSALS, OR GAS PILOTS; (14) EXCESSIVE LIME, MINERAL, OR ALKALINE BUILDUP; (15) EXPENSES DUE TO DISCONNECTION, DELIVERY, RETURN AND REINSTALLATION; (16) FAILURE OF ELECTRICAL COMPONENTS DUE TO CONNECTION OF CHEMICAL DISPENSING EQUIPMENT INSTALLED BY OTHERS; (17) FAILURE OF FACILITY WATER HEATER TO MAKE TEMPERATURE; (18) FAILURE TO MAINTAIN WATER HARDNESS LOWER THAN 3.0 GRAINS, PH BETWEEN 7.0 AND 8.5 AND TOTAL DISSOLVED SOLIDS BELOW 250 PPM; (19) FAILURE TO COMPLY WITH LOCAL ELECTRICAL BUILDING CODES; (20) LEAKS OR DAMAGE RESULTING FROM SUCH LEAKS CAUSED BY THE INSTALLER, INCLUDING THOSE AT MACHINE TABLE CONNECTIONS, OR BY CONNECTION OF CHEMICAL DISPENSING EQUIPMENT INSTALLED BY OTHERS; (21) OPENING OR CLOSING OF UTILITY SUPPLY VALVES OR SWITCHING OF ELECTRICAL SUPPLY CURRENT; (22) PERFORMANCE OF REGULAR MAINTENANCE AND CLEANING AS OUTLINED IN THE OPERATOR'S GUIDE; (23) REMOVAL OR REINSTALLATION OF INACCESSIBLE DISHMACHINES OR BUILT-IN FIXTURES THAT INTERFERE WITH SERVICING, REMOVAL OR REPLACEMENT OF THE DISHMACHINE; (24) REPLACEMENT WEAR ITEMS INCLUDING, BUT NOT LIMITED TO, CURTAINS, DRAIN BALLS, DOOR GUIDES, GASKETS, O-RINGS, SEALS, SQUEEZE TUBES, AND BEARINGS; (25) RESIDENTIAL USE; (26) USE WITH UTILITY SERVICE OTHER THAN THAT DESIGNATED ON THE RATING PLATE.

REVISION HISTORY

Revision	Date	Made by	Process	Details
A	9-10-25	JH	8939	Initial release of manual.



RackStar® 44

RackStar® 66

Electrically-heated, hot-water-sanitizing rack conveyor machine.



RackStar® 44 ER

RackStar® 66 ER

Electrically-heated, hot-water-sanitizing rack conveyor machine with Energy Recovery System.



RackStar® 44 NB

RackStar® 66 NB

Steam-heated, hot-water-sanitizing rack conveyor machine with no booster.
Not Energy Star rated.

RackStar® 44 S

RackStar® 66 S

Steam-heated, hot-water-sanitizing rack conveyor machine.
Not Energy Star rated.

Models also available in Higher Hood (25-inch Dish Clearance).

The manufacturer provides technical support for all of the dishmachines detailed in this manual.
We strongly recommend that you refer to this manual before making a call to our technical support staff.

Please have this manual open when you call so that our staff can refer you,
if necessary, to the proper page. Technical support is not available on holidays.

Contact technical support toll free at 1-888-800-5672.

Technical support is available for service personnel only.

TABLE OF CONTENTS

GUIDES

Symbols	1
Abbreviations & Acronyms	1

SPECIFICATIONS

RackStar/NB Dimensions	2
Energy Recovery Dimensions	6
Steam Dimensions	10
Steam Booster Dimensions	14
Side-loader Dimensions	15
Operating Parameters	16
Electrical Requirements	18

INSTALLATION

Installation Instructions	21
<i>Inspection</i>	21
<i>Unpacking</i>	21
<i>Leveling</i>	21
<i>Adjusting Doors</i>	21
<i>Plumbing</i>	21
<i>Drain Line Connection</i>	22
<i>Steam Line Connection</i>	23
<i>Electrical Power Connections</i>	23
<i>Motor Rotation</i>	24
<i>Ventilation</i>	24
<i>Thermostats</i>	24
<i>Table Limit Switch Option</i>	24
<i>Chemical Feeder Equipment</i>	25
<i>Connection Points</i>	25
<i>External Device Wiring</i>	27
<i>Exhaust Fan Timer</i>	27
<i>Curtains</i>	27

TABLE OF CONTENTS

OPERATION

Operating Instructions.....	28
<i>Preparation</i>	28
<i>Power Up</i>	28
<i>First Rack</i>	29
<i>Ware Preparation</i>	29
<i>Washing a Rack of Ware</i>	29
<i>Turbo Rinse</i>	29
<i>Operational Inspection</i>	29
<i>Shutdown & Cleaning</i>	30
<i>Display Instructions</i>	31
<i>Delime Instructions</i>	32

MAINTENANCE

Preventative Maintenance.....	33
-------------------------------	----

TROUBLESHOOTING

Troubleshooting	34
Programming	36
Fault Codes	37

PARTS

Control Box.....	39
Display	41
Miscellaneous Electrical Components	42
Wash Heater & Shroud.....	43
Wash Heaters	44
Pump Suction	45
Plumbing.....	46
Pre-wash Fill Plumbing.....	48
Energy Recovery Plumbing	49
Wash System.....	51
Pre-wash System.....	53
Rinse System.....	55
Plumbing Options	56
Rack Drive	57
Rack Rails.....	58
Drive Assembly	60

TABLE OF CONTENTS

PARTS

Ventilation Cowl	62
Ventilation Cowl for Unhooded Side-loader	63
Motor Overloads	64
Side-loaders	65
Side-loader Drive Linkage	68
Booster Assembly	69
Booster	71
Frame	72
Doors	73
Energy Recovery System	74
Steam Coil	76
Miscellaneous/Options	77

SCHEMATICS

208/230/460 V, 50/60 Hz, 3-Phase	78
208/230 V, 50/60 Hz, 1-Phase	79
Steam	80
Side-loader	81

ADDENDUM

Display Template	82
------------------------	----

SYMBOLS



- Risk of Injury to Personnel



- Risk of Damage to Equipment



- Risk of Electrical Shock



- Caustic Chemicals



- Reference Data Plate



- Lockout Electrical Power

NOTICE - Important Note



- Instructions Hyperlink

ABBREVIATIONS & ACRONYMS

ANSI - American National Standards Institute

CFM - Cubic Feet per Minute

ER - Energy Recovery

GHT - Garden Hose Thread

GPM - Gallons per Minute

GPG - Grains per Gallon

HP - Horse Power

Hz - Hertz

ID - Inside Diameter

kW - Kilowatts

MIN - Minimum

NFPA - National Fire Protection Association

NPT - National Pipe Thread

ppm - Parts per Million

PSI - Pounds per Square Inch

V - Volts

70°↑ - 70-degree Rise

SPECIFICATIONS

RACKSTAR 44/NB DIMENSIONS

44" LEFT-TO-RIGHT

LEGEND

- A - Electrical Connection
- B - Main Water Inlet
(1/2" NPT, 110 °F MIN (24 kW Booster),
or 180 °F MIN (No Booster))
- C - Drain Connection
(1 1/2" NPT)
- D - Vent Connections
(Including Dampers)

- — — — — - Open Door
- - - - - - - - - - - High Hood Option

All dimensions from the floor can be increased 1 3/4" using the machine's adjustable feet.

Items in red are not supplied with the machine.

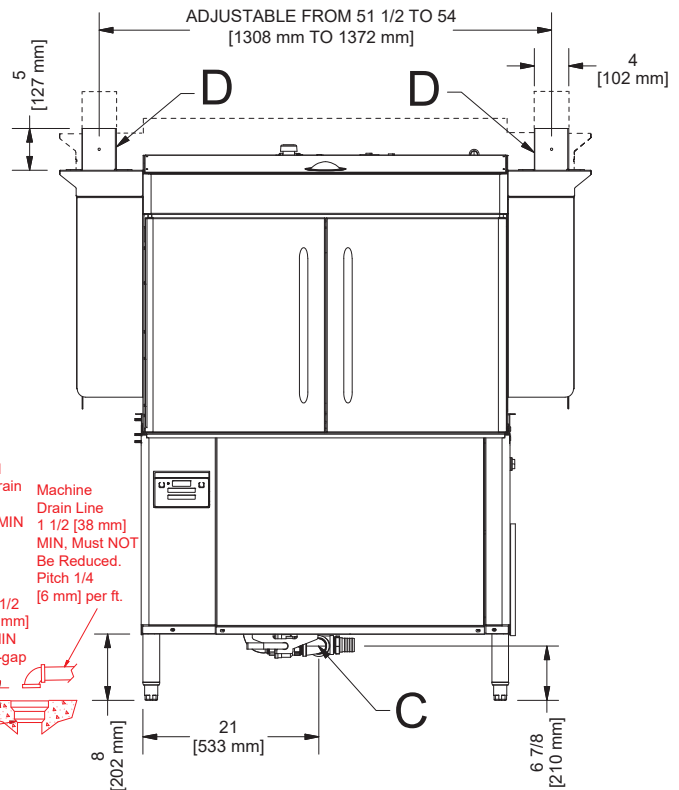
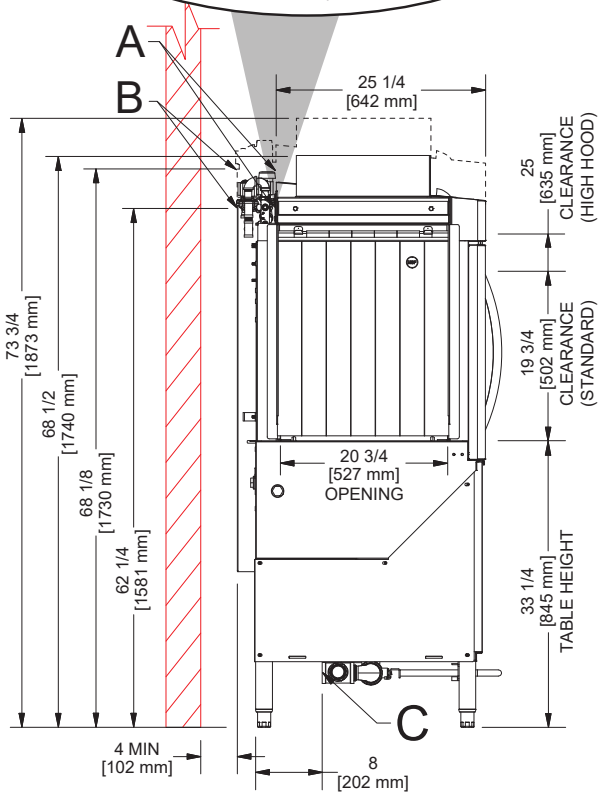
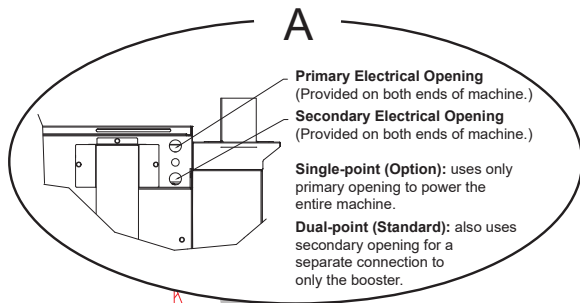
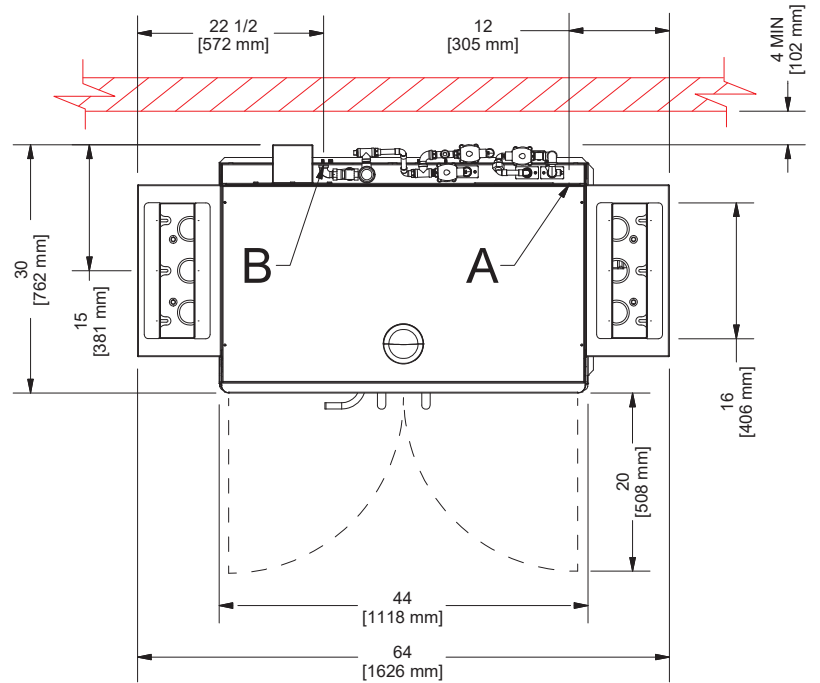

SPECIFICATIONS

RACKSTAR 66/NB DIMENSIONS

66" LEFT-TO-RIGHT

LEGEND

- A - Electrical Connection
- B - Main Water Inlet
- (1/2" NPT, 110 °F MIN (24 kW Booster) or 180 °F MIN (No Booster))
- C - Drain Connection (1 1/2" NPT)
- D - Vent Connections (Including Dampers)

- - Open Door
- - High Hood Option

All dimensions from the floor can be increased 1 3/4" using the machine's adjustable feet.

Items in red are not supplied with the machine.

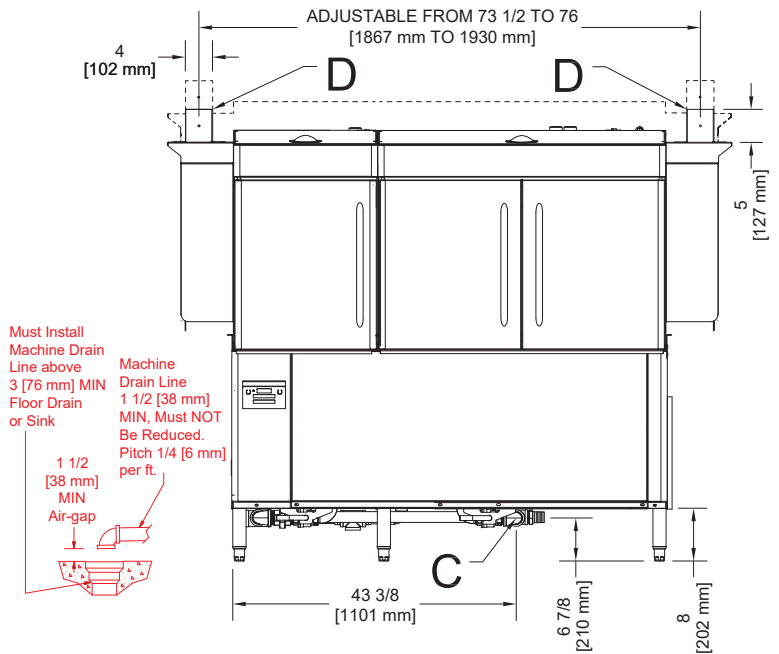
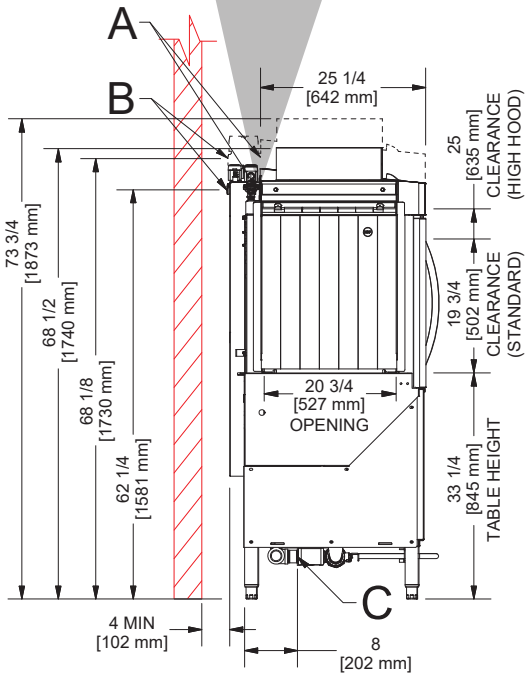
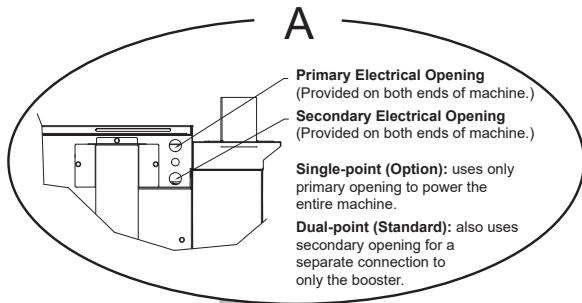
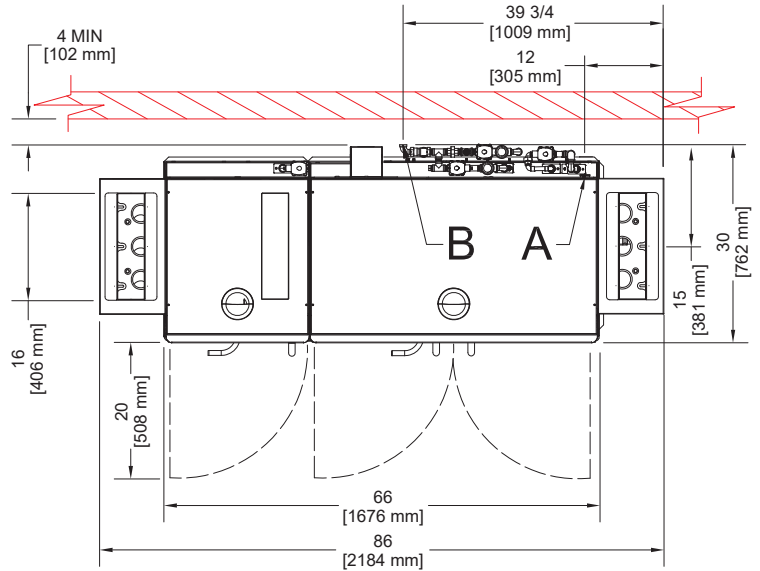

SPECIFICATIONS

RACKSTAR 66/NB DIMENSIONS

66" RIGHT-TO-LEFT

LEGEND

- A - Electrical Connection
- B - Main Water Inlet
(1/2" NPT, 110 °F MIN (24 kW Booster) or
180 °F MIN (No Booster))
- C - Drain Connection
(1 1/2" NPT)
- D - Vent Connections
(Including Dampers)

- - Open Door
- - High Hood Option

All dimensions from the floor can be increased
1 3/4" using the machine's adjustable feet.

Items in red are not supplied with the machine.

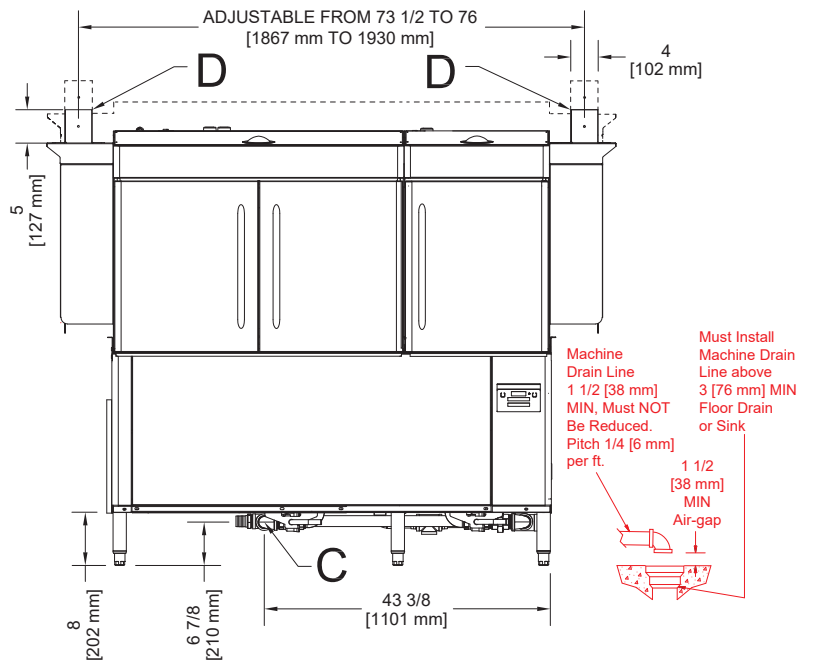
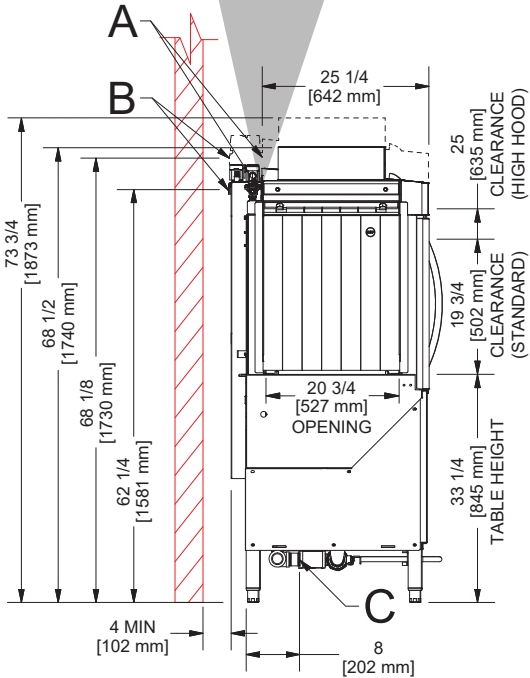
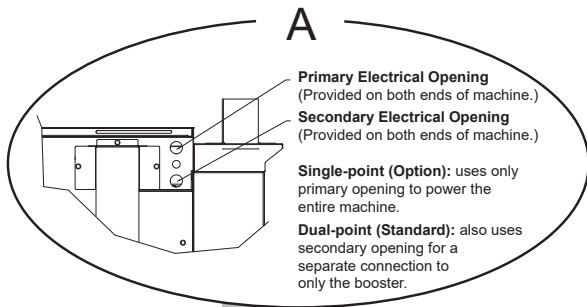
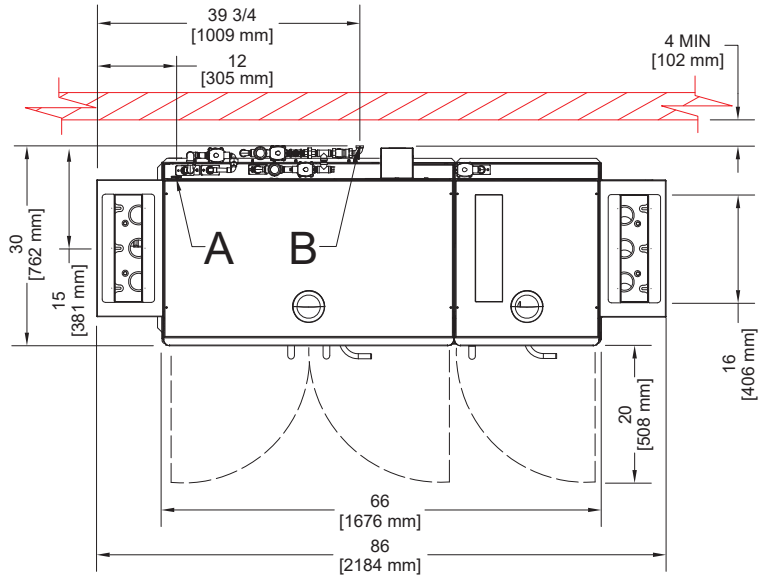

44" LEFT-TO-RIGHT

LEGEND

- A - Electrical Connection
- B - Water Inlet
(1/2" NPT, 110 °F MIN (24 kW Booster))
- C - Drain Connection
(1 1/2" NPT)
- D - Vent Connections
(Including Dampers)
- E - Energy Recovery Water Inlet
(1/2" NPT, 55 °F MIN)
- — — — — - Open Door
- - - - - - High Hood Option

All dimensions from the floor can be increased 1 3/4" using the machine's adjustable feet.

Items in red are not supplied with the machine.

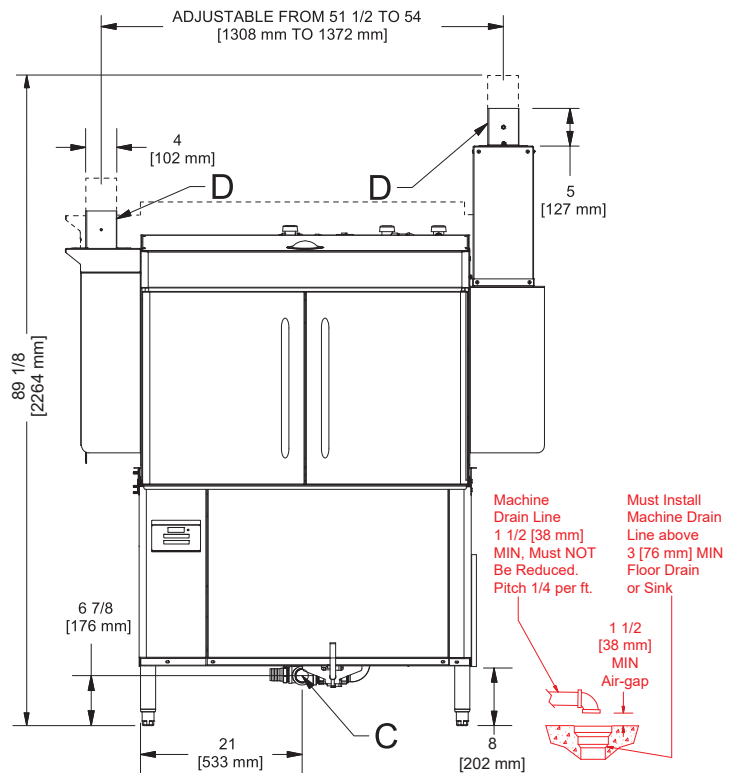
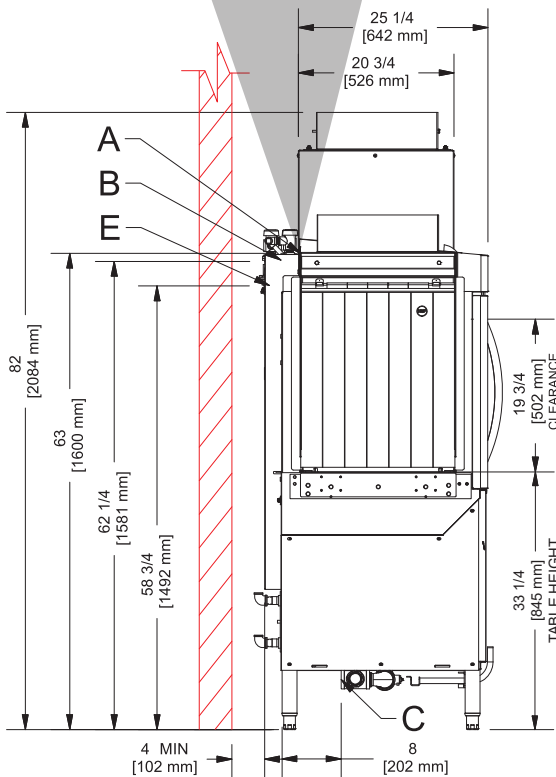
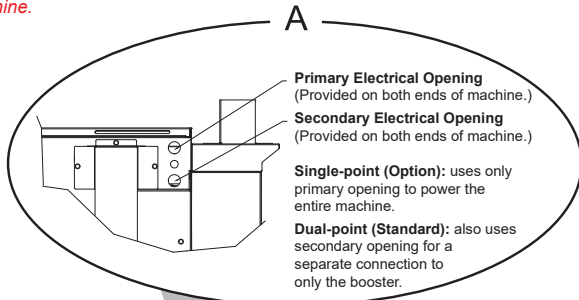
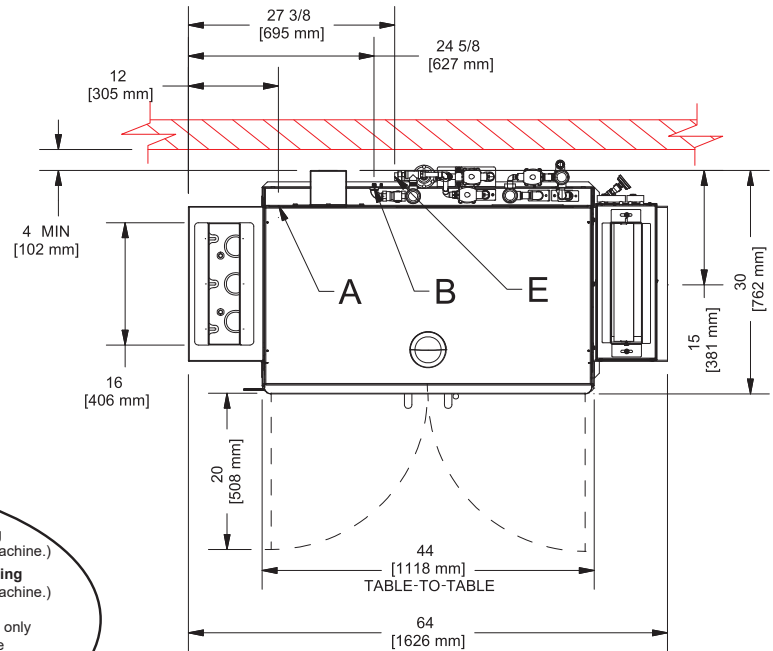

44" RIGHT-TO-LEFT

LEGEND

- A - Electrical Connection
- B - Water Inlet
(1/2" NPT, 110 °F MIN (27 kW Booster))
- C - Drain Connection
(1 1/2" NPT)
- D - Vent Connections
(Including Dampers)
- E - Energy Recovery Water Inlet
(1/2" NPT, 55 °F MIN)
- — — — — Open Door
- - - - - High Hood Option

All dimensions from the floor can be increased 1 3/4" using the machine's adjustable feet.

Items in red are not supplied with the machine.

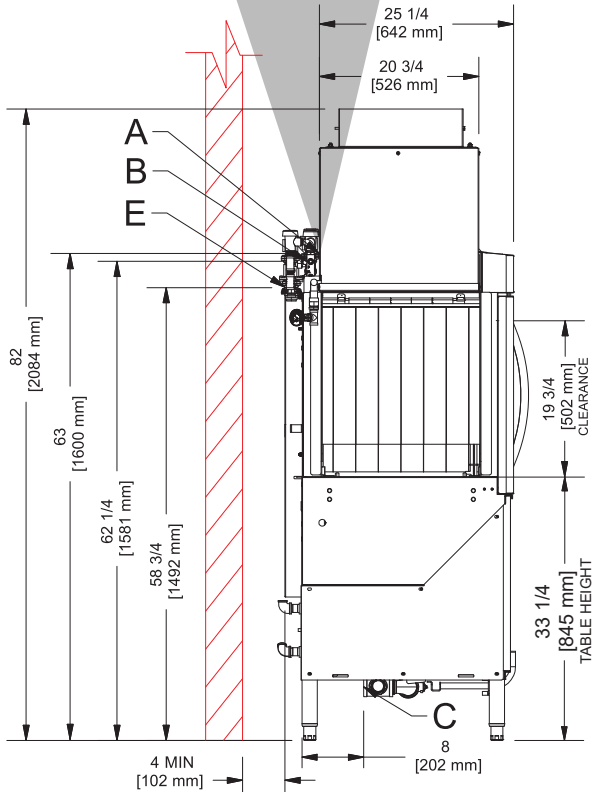
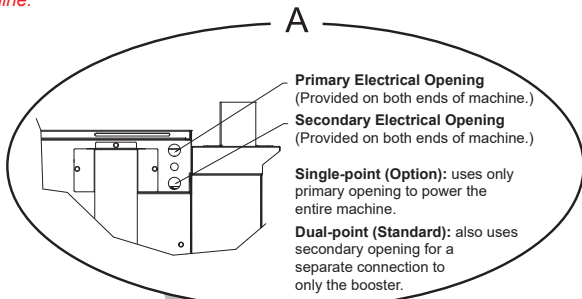
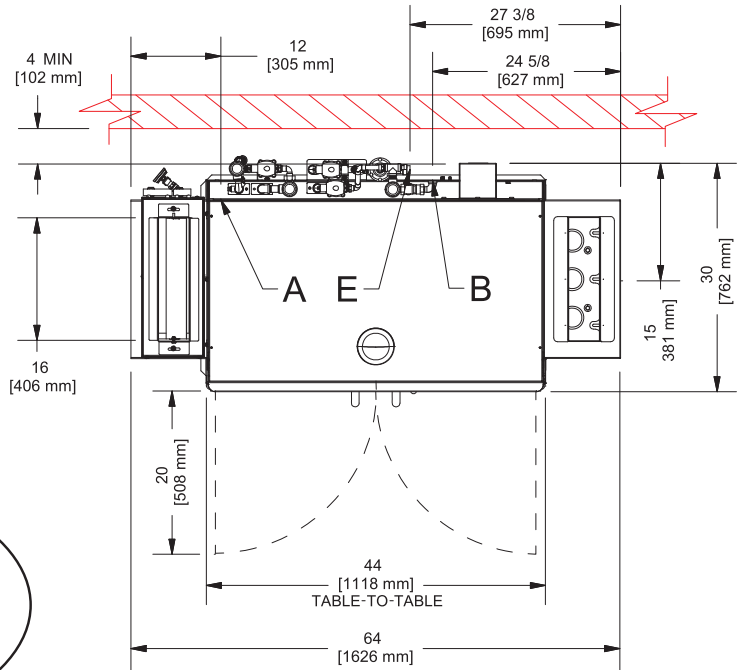

66" LEFT-TO-RIGHT

LEGEND

- A - Electrical Connection
- B - Water Inlet
(1/2" NPT, 110 °F MIN (24 kW Booster))
- C - Drain Connection
(1 1/2" NPT)
- D - Vent Connections
(Including Dampers)
- E - Energy Recovery Water Inlet
(1/2" NPT, 55 °F MIN)
- - Open Door
- - High Hood Option

All dimensions from the floor can be increased 1 3/4" using the machine's adjustable feet.

Items in red are not supplied with the machine.

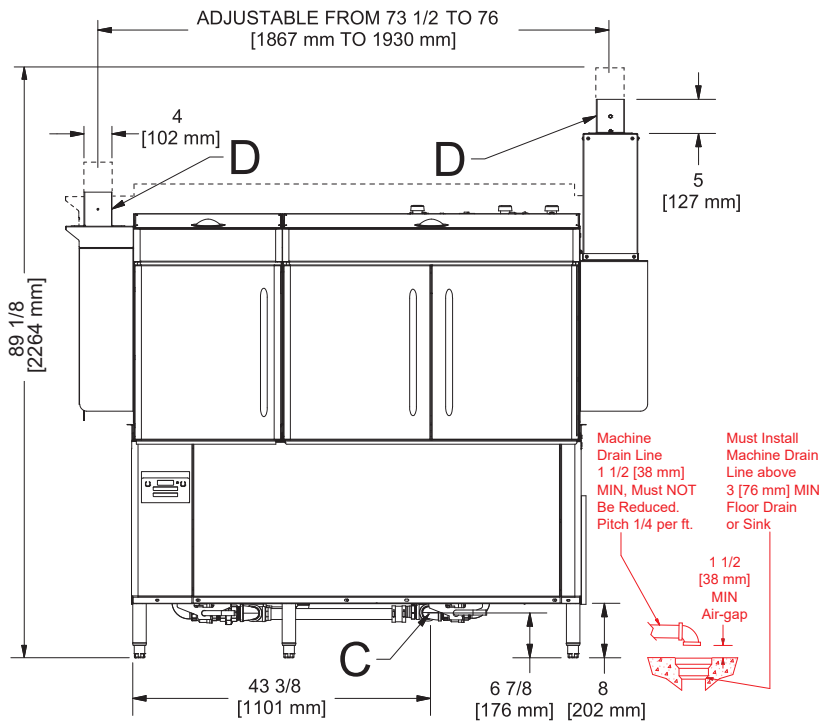
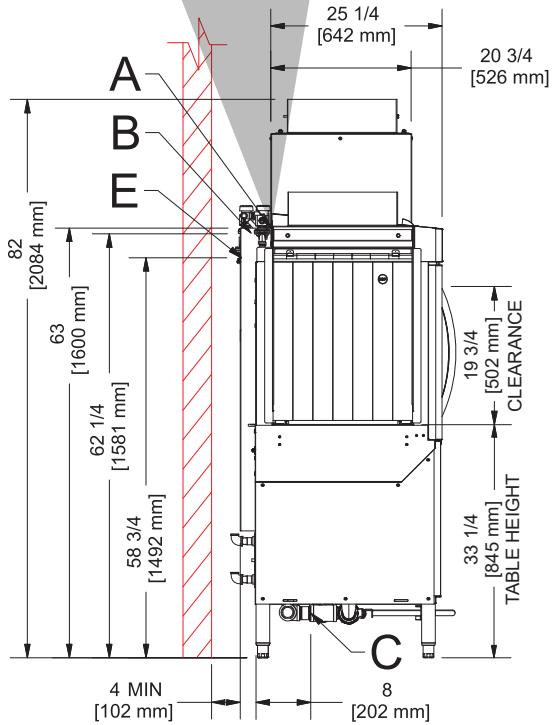
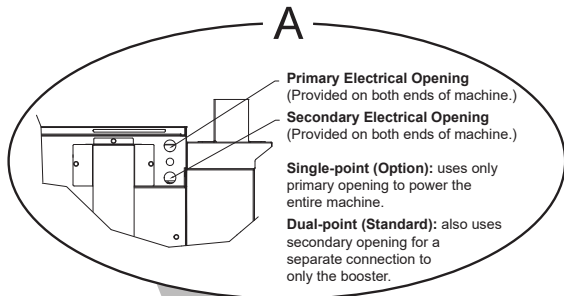
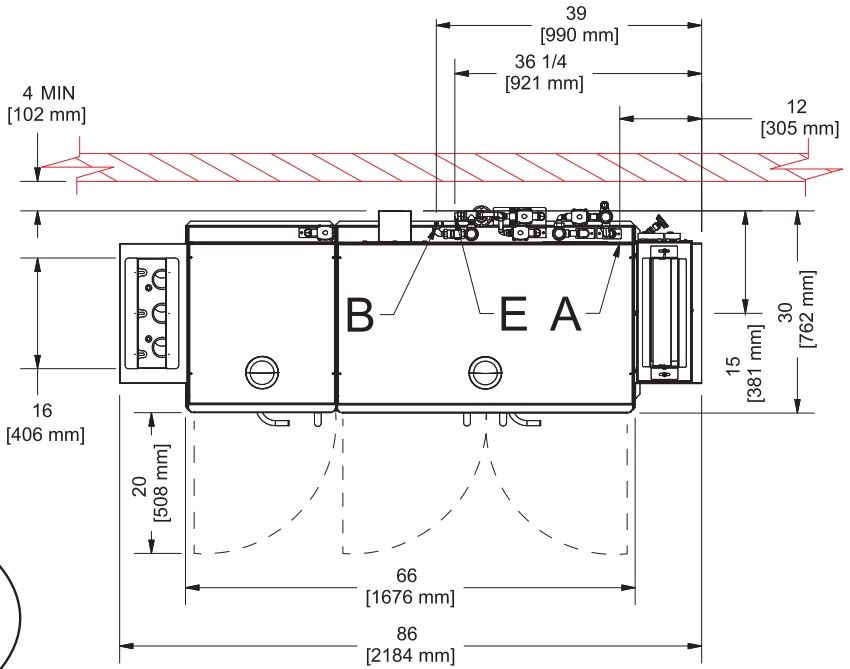

66" RIGHT-TO-LEFT

LEGEND

- A - Electrical Connection
- B - Water Inlet
(1/2" NPT, 110 °F MIN (24 kW Booster))
- C - Drain Connection
(1 1/2" NPT)
- D - Vent Connections
(Including Dampers)
- E - Energy Recovery Water Inlet
(1/2" NPT, 55 °F MIN)
- - Open Door
- - High Hood Option

All dimensions from the floor can be increased 1 3/4" using the machine's adjustable feet.

Items in red are not supplied with the machine.

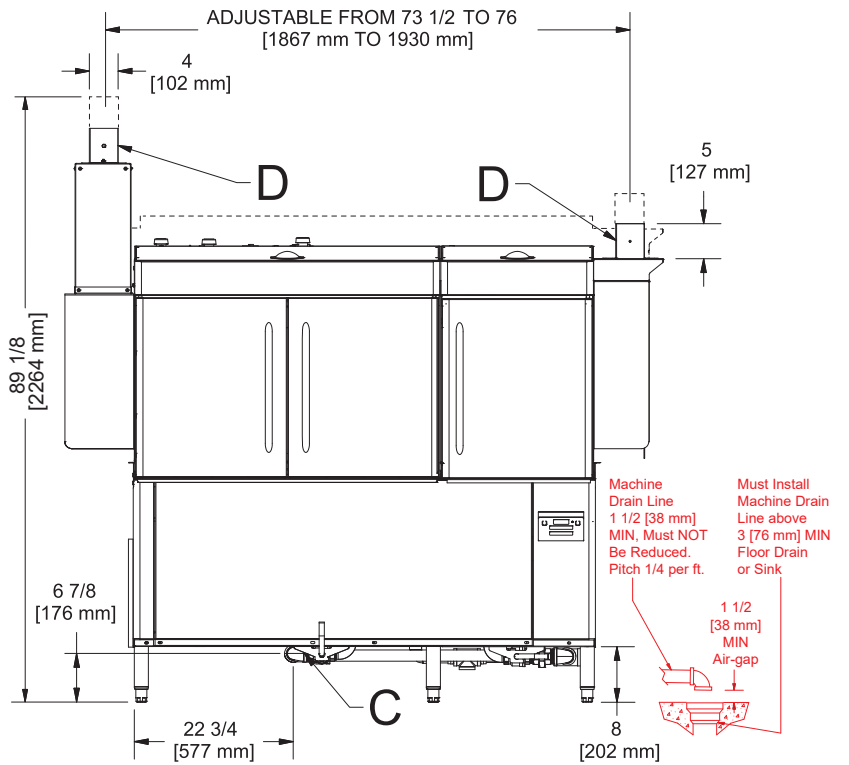
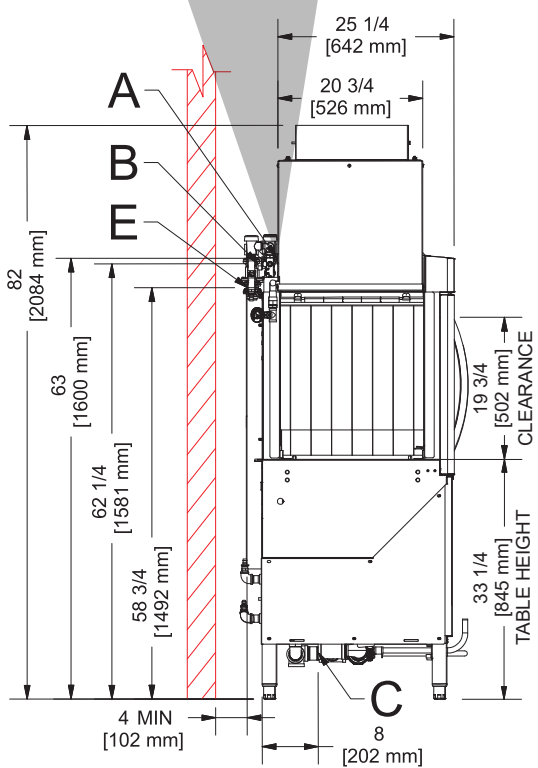
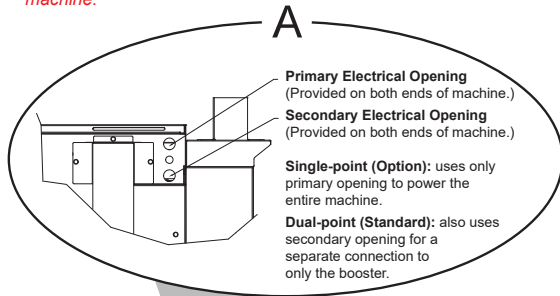
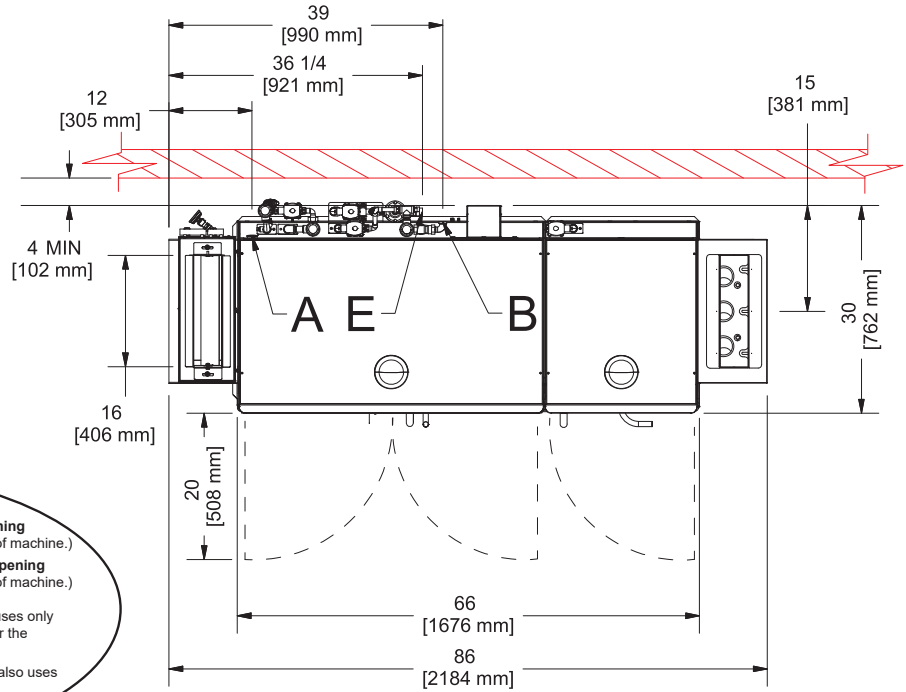

44" RIGHT-TO-LEFT

LEGEND

- A - Electrical Connection
- B - Main Water Inlet
(180 °F MIN, Supplied from Steam Booster)
- C - Drain Connection
(1 1/2" NPT)
- D - Vent Connections
(Including Dampers)
- E - Steam Connection
(3/4" NPT)

- - Open Door
- - High Hood Option

All dimensions from the floor can be increased 1 3/4" using the machine's adjustable feet.

Items in red are not supplied with the machine.

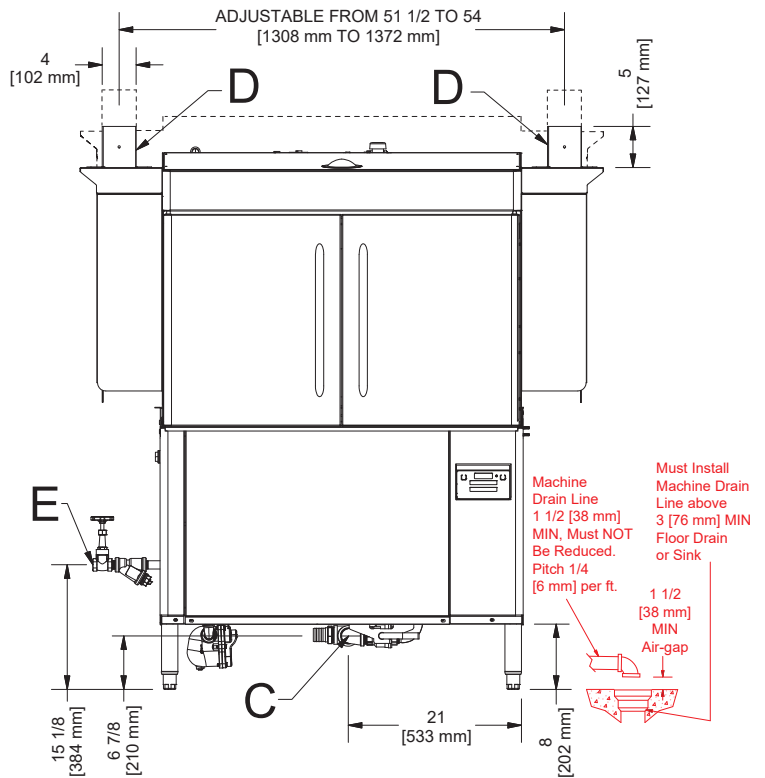
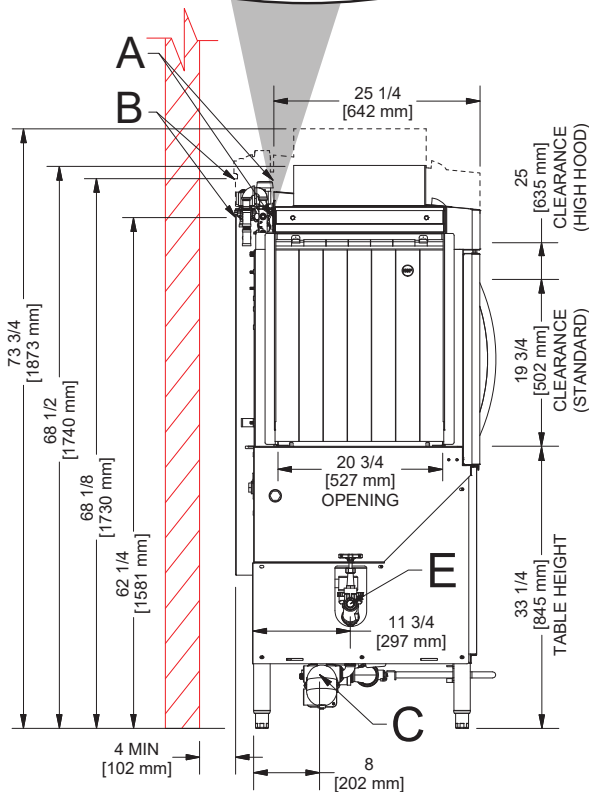
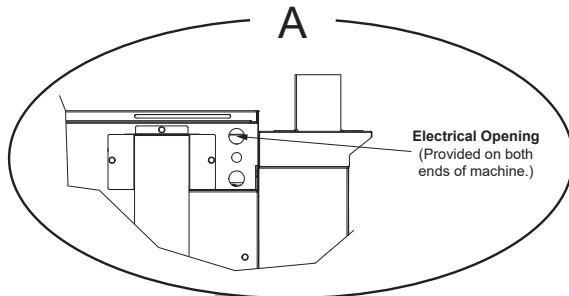
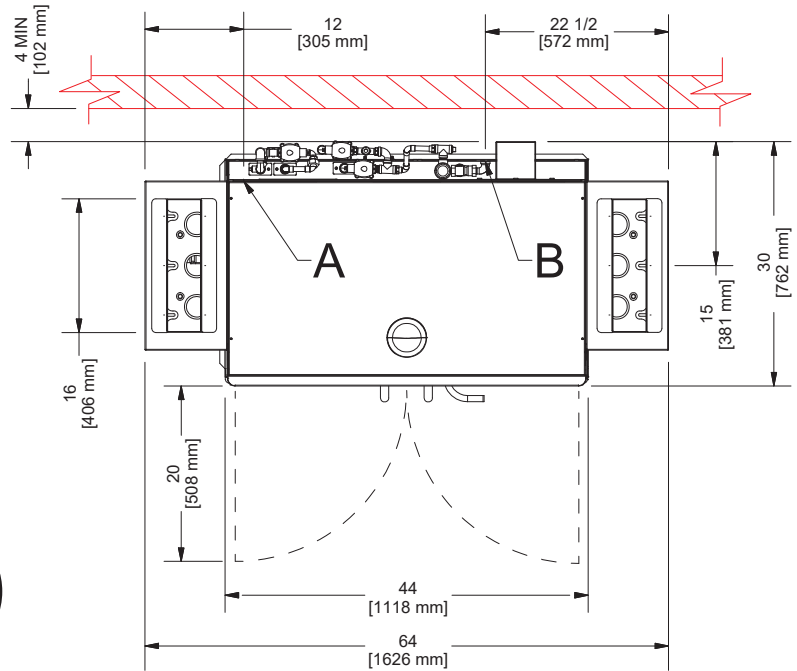

66" LEFT-TO-RIGHT

LEGEND

- A - Electrical Connection
- B - Main Water Inlet
(180 °F MIN, Supplied from Steam Booster)
- C - Drain Connection
(1 1/2" NPT)
- D - Vent Connections
(Including Dampers)
- E - Steam Connection
(3/4" NPT)

- - Open Door
- - High Hood Option

All dimensions from the floor can be increased 1 3/4" using the machine's adjustable feet.

Items in red are not supplied with the machine.

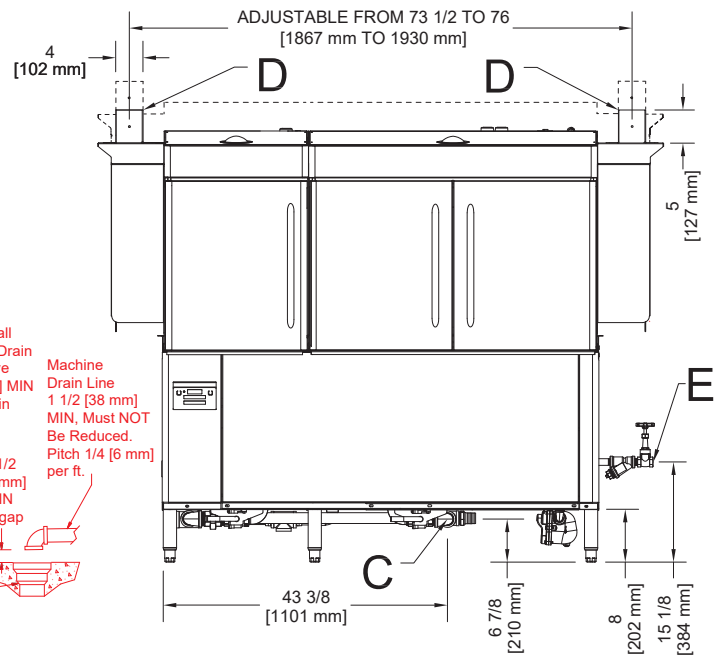
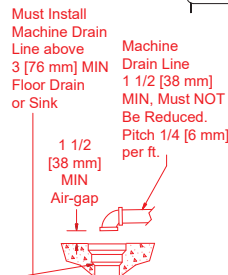
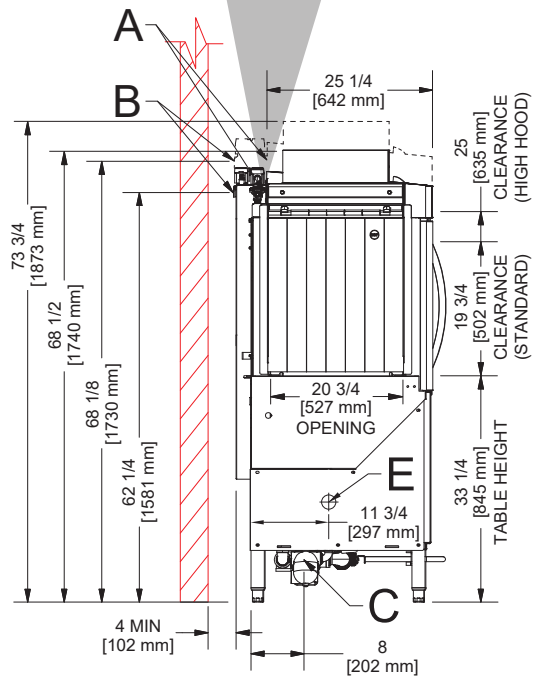
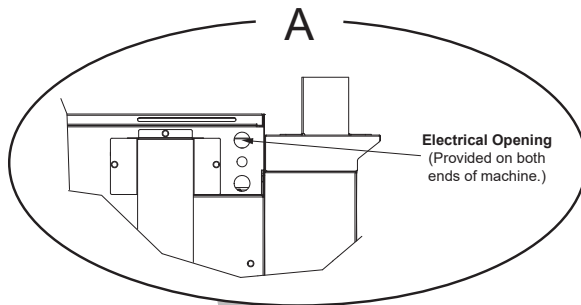
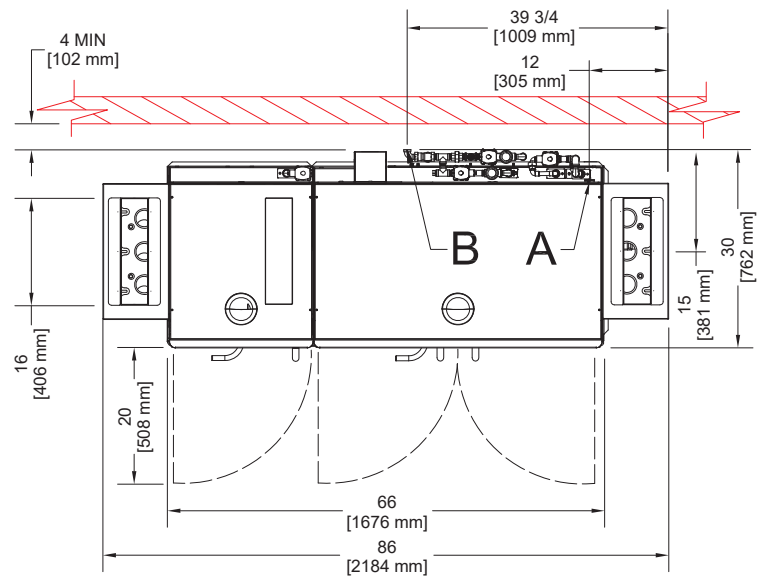

66" RIGHT-TO-LEFT

LEGEND

- A - Electrical Connection
- B - Main Water Inlet
(180 °F MIN, Supplied from Steam Booster)
- C - Drain Connection
(1 1/2" NPT)
- D - Vent Connections
(Including Dampers)
- E - Steam Connection
(3/4" NPT)

- — — — — Open Door
- - - - - High Hood Option

All dimensions from the floor can be increased 1 3/4" using the machine's adjustable feet.

Items in red are not supplied with the machine.

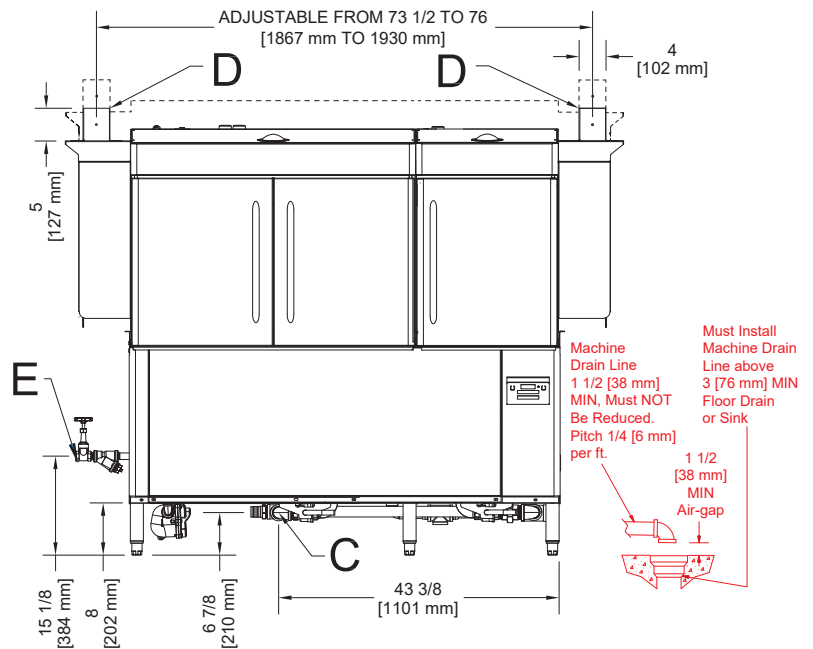
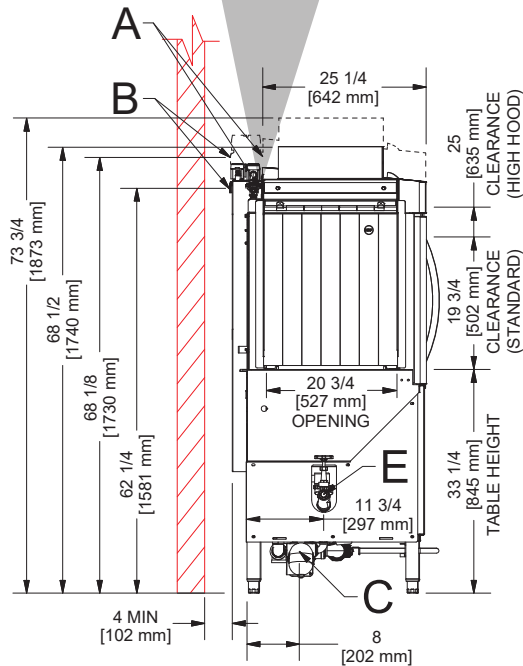
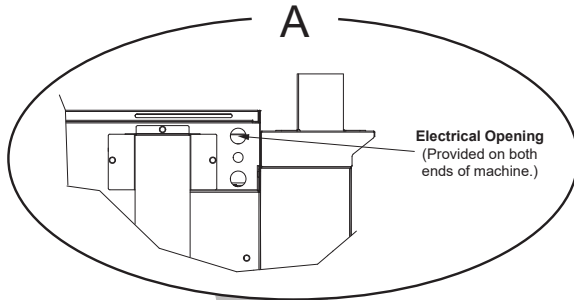
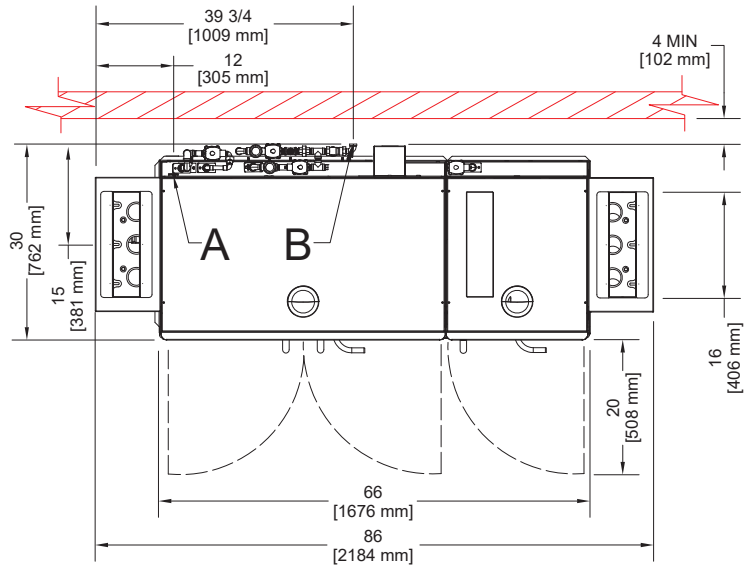

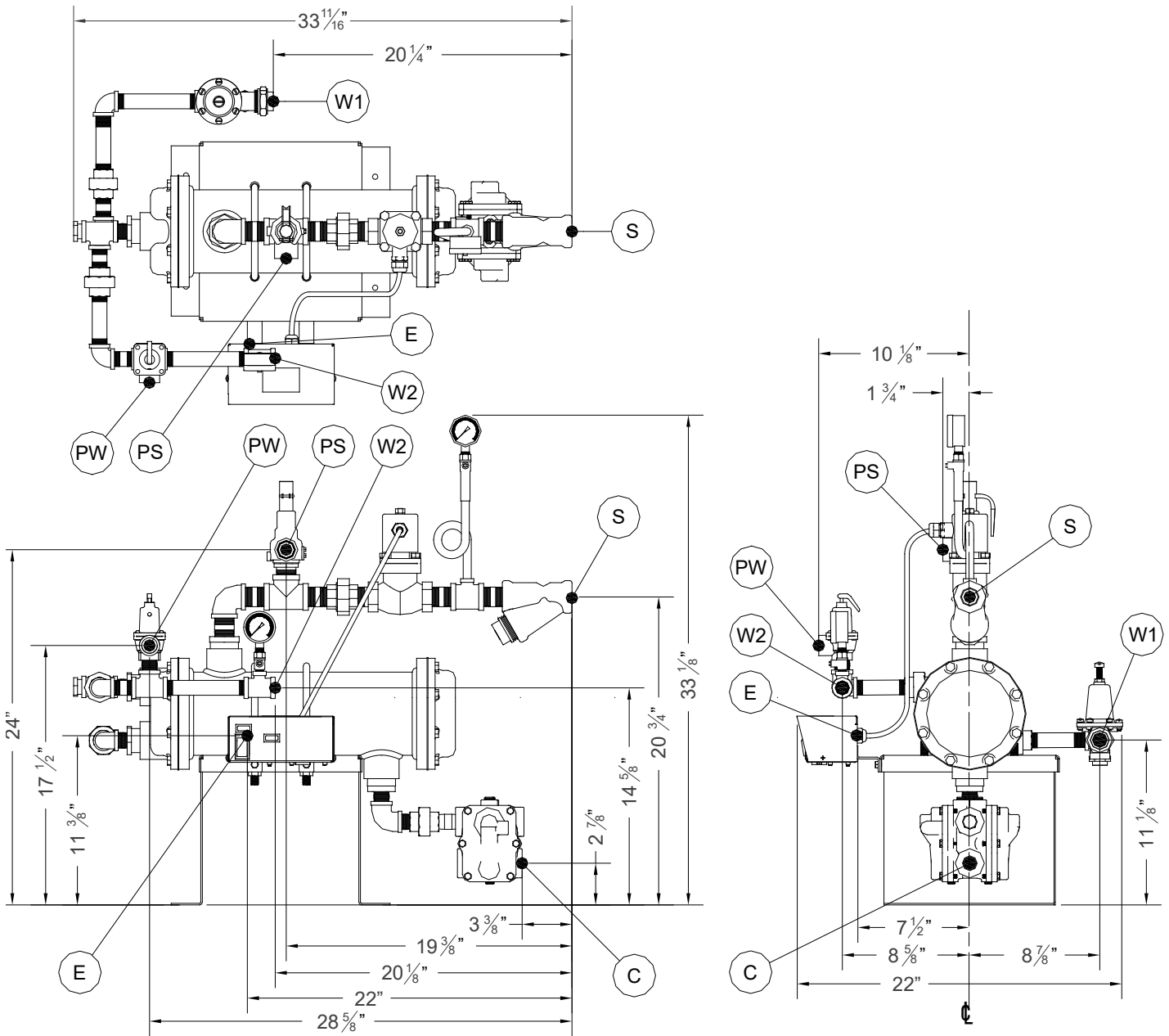

Click icon for the Steam Booster manual.



| | |
|----|--|
| E | Main Electrical Connection (7/8" Hole) |
| W1 | Main Inlet Water Connection (3/4" NPT, 110 °F MIN, 20 ± 5 PSI) |
| W2 | Water Outlet Connection (3/4" NPT) |
| PW | Water Pressure Relief Outlet (3/4" NPT) |

| | |
|----|--|
| PS | Steam Pressure Relief Outlet (1" NPT) |
| S | Steam Supply to Booster (1" NPT) |
| C | Steam Condensate Connection (3/4" NPT) |

23" L-R UNHOODED SIDE-LOADER

23" R-L UNHOODED SIDE-LOADER

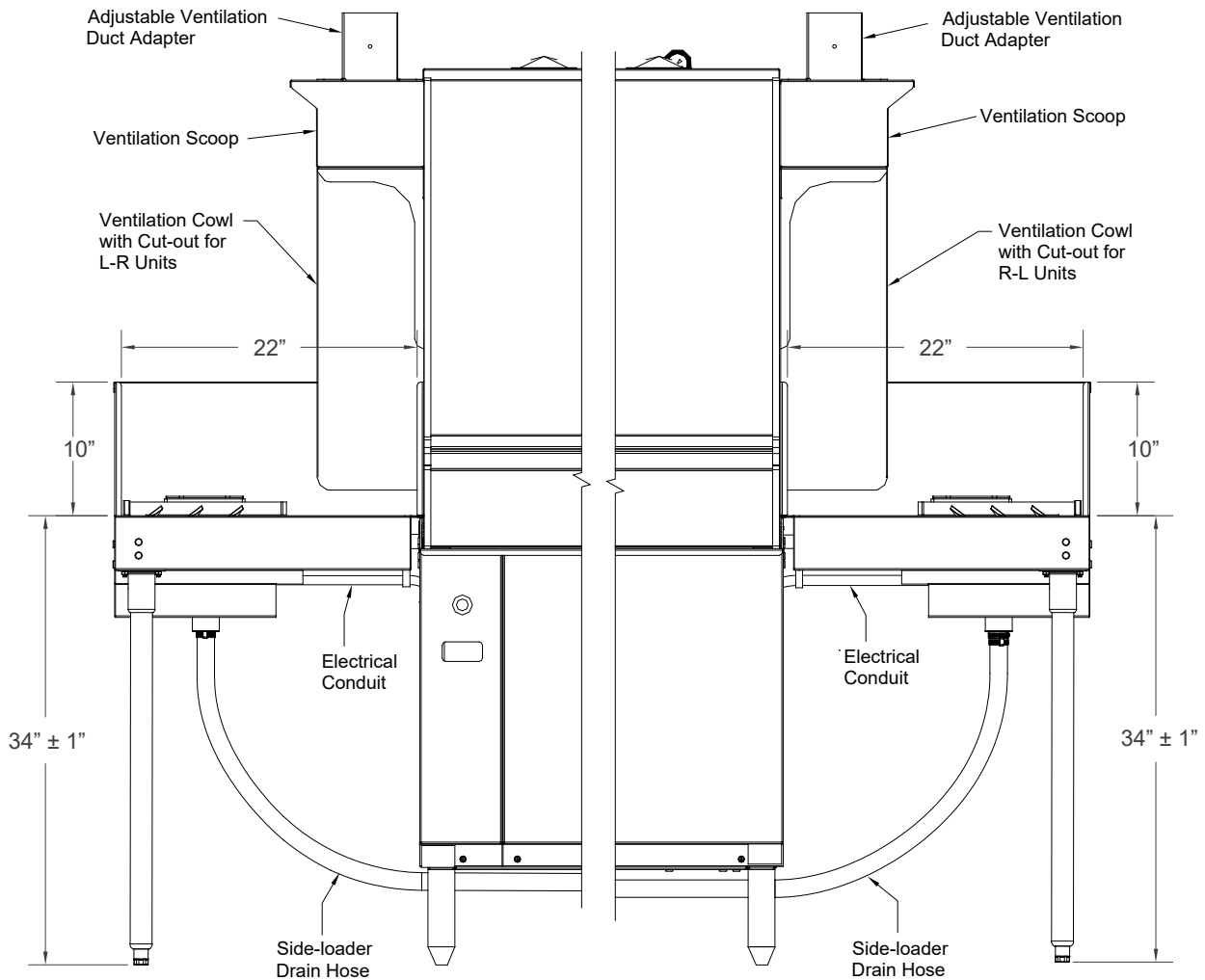
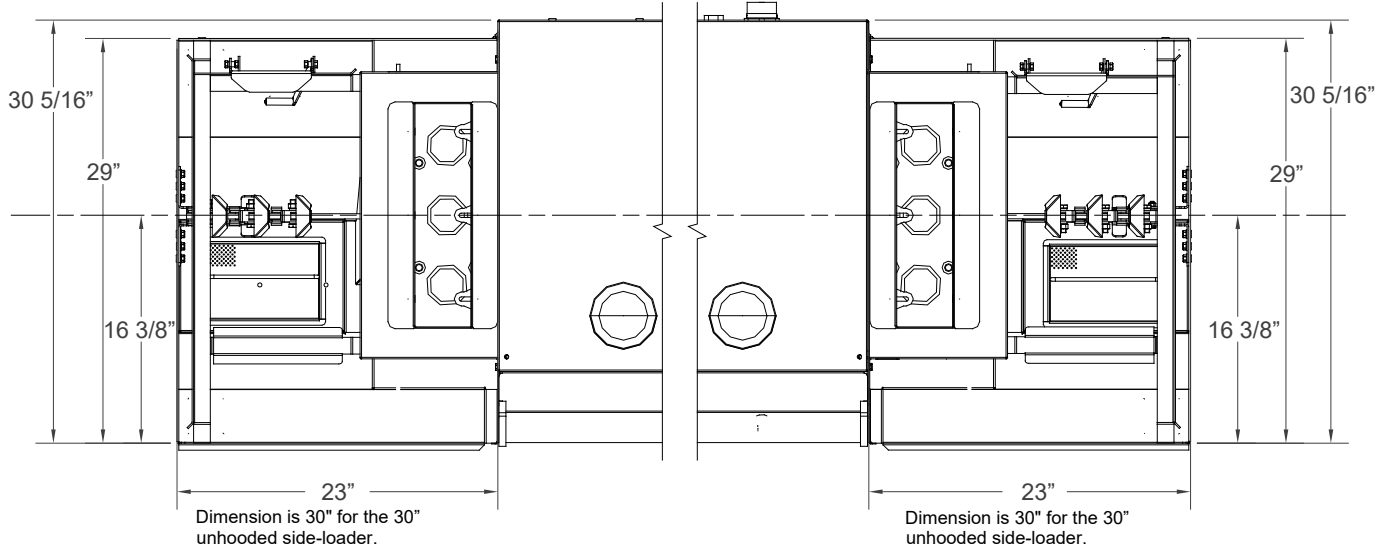

NOTICE Higher Hood (HH) models have the same operating parameters.

| Operating Capacity: | RackStar 44 | RackStar 66 | RackStar 44 ER | RackStar 66 ER | RackStar 44 NB | RackStar 66 NB | RackStar 44 S | RackStar 66 S |
|----------------------------|--------------------|--------------------|-----------------------|-----------------------|-----------------------|-----------------------|----------------------|----------------------|
| Racks per Hour | 229 | 226 | 224 | 226 | 229 | 229 | 223 | 223 |
| Dishes per Hour | 5,525 | 5,650 | 5,600 | 5,650 | 5,525 | 5,525 | 5,575 | 5,575 |
| Glasses per Hour | 8,244 | 8,136 | 8,064 | 8,136 | 8,244 | 8,244 | 8,028 | 8,028 |

| Tank Capacity (Gallons): | RackStar 44 | RackStar 66 | RackStar 44 ER | RackStar 66 ER | RackStar 44 NB | RackStar 66 NB | RackStar 44 S | RackStar 66 S |
|---------------------------------|--------------------|--------------------|-----------------------|-----------------------|-----------------------|-----------------------|----------------------|----------------------|
| Wash Tank | 25 | 25 | 25 | 25 | 25 | 25 | 25 | 25 |
| Pre-wash Tank | N/A | 15.8 | N/A | 15.8 | N/A | 15.8 | N/A | 15.8 |

| Electrical Loads: | RackStar 44 | RackStar 66 | RackStar 44 ER | RackStar 66 ER | RackStar 44 NB | RackStar 66 NB | RackStar 44 S | RackStar 66 S |
|--------------------------|--------------------|--------------------|-----------------------|-----------------------|-----------------------|-----------------------|----------------------|----------------------|
| Wash Motor HP | 3 | 3 | 3 | 3 | 3 | 3 | 3 | 3 |
| Drive Motor HP | 1/4 | 1/4 | 1/4 | 1/4 | 1/4 | 1/4 | 1/4 | 1/4 |
| Pre-wash Motor HP | N/A | 2 | N/A | 2 | N/A | 2 | N/A | 2 |
| Wash Heater kW | 15 | 15 | 15 | 15 | 15 | 15 | N/A | N/A |
| Booster Heater kW | 24 | 24 | 24 | 24 | N/A | N/A | N/A | N/A |

NOTICE



Always refer to the machine data plate for specific electrical and water requirements. The material provided on this page is for reference only and may change without notice.

NOTICE Higher Hood (HH) models have the same operating parameters.

| Water Temperatures (°F): | RackStar 44 | RackStar 66 | RackStar 44 ER | RackStar 66 ER | RackStar 44 NB | RackStar 66 NB | RackStar 44 S | RackStar 66 S |
|---------------------------------|--------------------|--------------------|-----------------------|-----------------------|-----------------------|-----------------------|--------------------------|--------------------------|
| Pre-wash | N/A | 110-140 | N/A | 110-140 | N/A | 110-140 | N/A | 110-140 |
| Minimum Wash | 160 | 160 | 160 | 160 | 160 | 160 | 160 | 160 |
| Minimum Rinse | 180 | 180 | 180 | 180 | 180 | 180 | 180 | 180 |
| Minimum Incoming Water | 110 | 110 | 110 | 110 | 180 | 180 | 180 (from Steam Booster) | 180 (from Steam Booster) |
| Minimum Incoming Cold Water | N/A | N/A | 55 | 55 | N/A | N/A | N/A | N/A |

| Other Water Requirements: | RackStar 44 | RackStar 66 | RackStar 44 ER | RackStar 66 ER | RackStar 44 NB | RackStar 66 NB | RackStar 44 S | RackStar 66 S |
|----------------------------------|--------------------|--------------------|-----------------------|-----------------------|-----------------------|-----------------------|----------------------|----------------------|
| Water Flow Pressure (PSI) | 20 ± 2 | 20 ± 2 | 20 ± 2 | 20 ± 2 | 20 ± 2 | 20 ± 2 | 15 | 15 |
| Flow Rate Minimum (GPM) | 1.3 | 1.3 | 1.3 | 1.3 | 1.3 | 1.3 | 1.3 | 1.3 |
| Water Line Size (NPT) | 1/2" | 1/2" | 1/2" | 1/2" | 1/2" | 1/2" | 1/2" | 1/2" |
| Drain Line Size (NPT) | 1 1/2" | 1 1/2" | 1 1/2" | 1 1/2" | 1 1/2" | 1 1/2" | 1 1/2" | 1 1/2" |

| Steam Requirements: | RackStar 44 S | RackStar 66 S |
|--------------------------------|----------------------|----------------------|
| Steam Line for Wash Tank (NPT) | 3/4" | 3/4" |
| Steam Flow Pressure (PSI) | 10-30 | 10-30 |
| Consumption @ 15 PSI (lbs/hr) | 60 | 60 |

NOTICE



Always refer to the machine data plate for specific electrical and water requirements. The material provided on this page is for reference only and may change without notice.

ELECTRICAL REQUIREMENTS



All electrical ratings provided in this manual are for reference only. Always refer to machine data plate to get exact electrical information for this machine. **All electrical work performed on machines should be done in accordance with applicable local, state, territorial, and national codes.** Work should only be performed by qualified electricians and authorized service agents.

Available Electrical Characteristics:

- 208 V, 60 Hz, Three-phase
- 230 V, 60 Hz, Three-phase
- 460 V, 60 Hz, Three-phase
- 208 V, 60 Hz, Single-phase
- 230 V, 60 Hz, Single-phase

Available Wash Tank Heater:

- 15 kW

Booster heater requires a separate electrical connection unless single-point option is selected.

Available Booster Tank Heaters:

- None
- 24 kW



Local codes may require more stringent protection than what is displayed here and on the data plate. Always verify with an electrical service contractor that circuit protection is adequate and meets all applicable national and local codes. Numbers in this manual are for reference and may change without notice. If using a third-party external booster, consult booster manufacturer for booster information. With dual-point connection (standard), booster heater has its own connection. Imbalanced wild leg goes to L3. Also see Motor Rotation section.

RackStar 44 Dual-point Connection (Standard)

Includes RackStar 44, RackStar 44 HH, RackStar 44 ER, and RackStar 44 HH ER with 24 kW booster.

Machine Terminal Block

| Volts | Phase | Freq | Wash Motor | Drive Motor | Wash Heater | Total Load | MCA | MOP |
|-------|-------|-------|------------|-------------|-------------|------------|--------|-------|
| 208 | 3 | 60 Hz | 9.2 A | 1.1 A | 41.6 A | 51.9 A | 54.2 A | 60 A |
| 230 | 3 | 60 Hz | 8.6 A | 1.1 A | 34.6 A | 44.3 A | 46.4 A | 50 A |
| 460 | 3 | 60 Hz | 4.3 A | 0.7 A | 17.3 A | 22.3 A | 23.4 A | 25 A |
| 208 | 1 | 60 Hz | 13.6 A | 1.3 A | 72.1 A | 87.0 A | 90.4 A | 100 A |
| 230 | 1 | 60 Hz | 12.1 A | 1.3 A | 59.9 A | 73.3 A | 76.3 A | 85 A |

Booster Terminal Block

| Booster Heater | MCA | MOP |
|----------------|---------|-------|
| 66.6 A | 67.9 A | 70 A |
| 55.3 A | 56.6 A | 60 A |
| 27.7 A | 29.0 A | 30 A |
| 115.4 A | 116.7 A | 120 A |
| 95.8 A | 97.1 A | 100 A |

RackStar 44 Single-point Connection (Option)

Includes RackStar 44, RackStar 44 HH, RackStar 44 ER, and RackStar 44 HH ER with 24 kW booster.

| Volts | Phase | Freq | Wash Motor | Drive Motor | Wash Heater | Booster Heater | Total Load | MCA | MOP |
|-------|-------|-------|------------|-------------|-------------|----------------|------------|---------|-------|
| 208 | 3 | 60 Hz | 9.2 A | 1.1 A | 41.6 A | 66.6 A | 118.6 A | 120.9 A | 130 A |
| 230 | 3 | 60 Hz | 8.6 A | 1.1 A | 34.6 A | 55.3 A | 99.6 A | 101.8 A | 110 A |
| 460 | 3 | 60 Hz | 4.3 A | 0.7 A | 17.3 A | 27.7 A | 50.0 A | 51.1 A | 55 A |
| 208 | 1 | 60 Hz | 13.6 A | 1.3 A | 72.1 A | 115.4 A | 202.4 A | 205.8 A | 215 A |
| 230 | 1 | 60 Hz | 12.1 A | 1.3 A | 59.9 A | 95.8 A | 169.1 A | 172.1 A | 180 A |

RackStar 44 NB

Single-point connection is standard on No Booster (NB) models.

| Volts | Phase | Freq | Wash Motor | Drive Motor | Wash Heater | Total Load | MCA | MOP |
|-------|-------|-------|------------|-------------|-------------|------------|--------|-------|
| 208 | 3 | 60 Hz | 9.2 A | 1.1 A | 41.6 A | 51.9 A | 54.2 A | 60 A |
| 230 | 3 | 60 Hz | 8.6 A | 1.1 A | 34.6 A | 44.3 A | 46.4 A | 55 A |
| 460 | 3 | 60 Hz | 4.3 A | 0.7 A | 17.3 A | 22.3 A | 23.4 A | 25 A |
| 208 | 1 | 60 Hz | 13.6 A | 1.3 A | 72.1 A | 87.0 A | 90.4 A | 100 A |
| 230 | 1 | 60 Hz | 12.1 A | 1.3 A | 59.9 A | 73.2 A | 76.3 A | 85 A |

RackStar 44 S

Single-point connection is standard on Steam (S) models.

| Volts | Phase | Freq | Wash Motor | Drive Motor | Total Load | MCA | MOP |
|-------|-------|-------|------------|-------------|------------|--------|------|
| 208 | 3 | 60 Hz | 9.2 A | 1.1 A | 10.3 A | 12.6 A | 20 A |
| 230 | 3 | 60 Hz | 8.6 A | 1.1 A | 9.7 A | 11.9 A | 20 A |
| 460 | 3 | 60 Hz | 4.3 A | 0.7 A | 5.0 A | 6.1 A | 15 A |



Local codes may require more stringent protection than what is displayed here and on the data plate. Always verify with an electrical service contractor that circuit protection is adequate and meets all applicable national and local codes. Numbers in this manual are for reference and may change without notice. If using a third-party external booster, consult booster manufacturer for booster information. With dual-point connection (standard), booster heater has its own connection. Imbalanced wild leg goes to L3. Also see Motor Rotation section.

RackStar 66 Dual-point Connection (Standard)
Includes RackStar 66, RackStar 66 HH, RackStar 66 ER, and RackStar 66 HH ER with 24 kW booster.

Machine Terminal Block

| Volts | Phase | Freq | PW Motor | Wash Motor | Drive Motor | Wash Heater | Total Load | MCA | MOP |
|-------|-------|-------|----------|------------|-------------|-------------|------------|---------|-------|
| 208 | 3 | 60 Hz | 6.2 A | 9.2 A | 1.1 A | 41.6 A | 58.1 A | 60.4 A | 65 A |
| 230 | 3 | 60 Hz | 6.2 A | 8.6 A | 1.1 A | 34.6 A | 50.5 A | 52.6 A | 60 A |
| 460 | 3 | 60 Hz | 3.1 A | 4.3 A | 0.7 A | 17.3 A | 25.4 A | 26.5 A | 30 A |
| 208 | 1 | 60 Hz | 10.2 A | 13.6 A | 1.3 A | 72.1 A | 97.2 A | 100.6 A | 110 A |
| 230 | 1 | 60 Hz | 9.4 A | 12.1 A | 1.3 A | 59.9 A | 82.6 A | 97.1 A | 100 A |

Booster Terminal Block

| Booster Heater | MCA | MOP |
|----------------|---------|-------|
| 66.6 A | 67.9 A | 70 A |
| 55.3 A | 56.6 A | 60 A |
| 27.7 A | 29.0 A | 30 A |
| 115.4 A | 116.7 A | 120 A |
| 95.8 A | 97.1 A | 100 A |

RackStar 66 Single-point Connection (Option)
Includes RackStar 44, RackStar 44 HH, RackStar 44 ER, and RackStar 44 HH ER with 24 kW booster.

| Volts | Phase | Freq | PW Motor | Wash Motor | Drive Motor | Wash Heater | Booster Heater | Total Load | MCA | MOP |
|-------|-------|-------|----------|------------|-------------|-------------|----------------|------------|---------|-------|
| 208 | 3 | 60 Hz | 6.2 A | 9.2 A | 1.1 A | 41.6 A | 66.6 A | 124.8 A | 127.1 A | 135 A |
| 230 | 3 | 60 Hz | 6.2 A | 8.6 A | 1.1 A | 34.6 A | 55.3 A | 105.8 A | 108.0 A | 115 A |
| 460 | 3 | 60 Hz | 3.1 A | 4.3 A | 0.7 A | 17.3 A | 27.7 A | 53.1 A | 54.2 A | 55 A |
| 208 | 1 | 60 Hz | 10.2 A | 13.6 A | 1.3 A | 72.1 A | 115.4 A | 212.6 A | 216 A | 225 A |
| 230 | 1 | 60 Hz | 9.4 A | 12.1 A | 1.3 A | 59.9 A | 95.8 A | 178.5 A | 181.5 A | 190 A |

RackStar 66 NB

Single-point connection is standard on No Booster (NB) models.

| Volts | Phase | Freq | PW Motor | Wash Motor | Drive Motor | Wash Heater | Total Load | MCA | MOP |
|-------|-------|-------|----------|------------|-------------|-------------|------------|---------|-------|
| 208 | 3 | 60 Hz | 6.2 A | 9.2 A | 1.1 A | 41.6 A | 58.1 A | 60.4 A | 65 A |
| 230 | 3 | 60 Hz | 6.2 A | 8.6 A | 1.1 A | 34.6 A | 50.5 A | 52.6 A | 60 A |
| 460 | 3 | 60 Hz | 3.1 A | 4.3 A | 0.7 A | 17.3 A | 25.4 A | 26.5 A | 30 A |
| 208 | 1 | 60 Hz | 10.2 A | 13.6 A | 1.3 A | 72.1 A | 97.2 A | 100.6 A | 110 A |
| 230 | 1 | 60 Hz | 9.4 A | 12.1 A | 1.3 A | 59.9 A | 82.6 A | 85.7 A | 95 A |

RackStar 66 S

Single-point connection is standard on Steam (S) models.

| Volts | Phase | Freq | PW Motor | Wash Motor | Drive Motor | Total Load | MCA | MOP |
|-------|-------|-------|----------|------------|-------------|------------|--------|------|
| 208 | 3 | 60 Hz | 6.2 A | 9.2 A | 1.1 A | 16.5 A | 18.8 A | 25 A |
| 230 | 3 | 60 Hz | 6.2 A | 8.6 A | 1.1 A | 15.9 A | 18.1 A | 25 A |
| 460 | 3 | 60 Hz | 3.1 A | 4.3 A | 0.7 A | 8.1 A | 9.2 A | 15 A |

INSPECTION

Do not throw away the packaging if damage is evident!

Before installing machine, check packaging and machine for damage. If packaging is damaged, the machine might also be damaged. If there is damage to both packaging and machine, do not throw away packaging. The machine has been inspected and packed at the factory and is expected to arrive to you in new, undamaged condition. However, rough handling by carriers or others might result in damage to machine while in transit. If so, do not return machine to manufacturer. Instead, contact carrier and ask them to send a representative to the site to inspect damage and complete an inspection report. Carrier and dealer that sold the machine must be contacted within 48 hours of receiving machine.

UNPACKING

While unpacking machine, ensure there are no missing parts. If an item is missing, contact manufacturer immediately.

LEVELING

The machine is designed to operate while level. This is important to prevent any damage to machine during operation and to ensure best results. The machine comes equipped with adjustable bullet feet, which can be turned using a pair of pliers. Verify machine is level front-to-back and side-to-side before making any electrical or plumbing connections.

ADJUSTING DOORS

A level machine is important for proper door function as well. If machine is level and doors are still not functioning properly:

1. Identify top door hinges, located in top-front of machine.

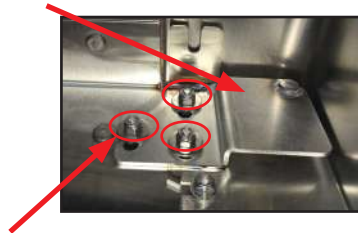

2. Loosen three nuts on each hinge, which allows doors to be adjusted.
3. Adjust doors to their proper position.
4. Tighten-down three nuts on each hinge.

PLUMBING

Plumber MUST flush the incoming water line!

All plumbing connections must adhere to local, state, territorial, and national codes. The installing plumber is responsible for ensuring incoming water lines are flushed of debris before connecting the machine. Note that chips and materials from cutting processes can become lodged in solenoid valves and prevent them from opening or closing. Any valves found to be fouled or defective because of foreign matter left in the water line and any subsequent water damage are not the responsibility of the manufacturer.

A water hardness test MUST be performed.

If water hardness tests at greater than 3 GPG, install the Scaltrol Water Treatment system (see Plumbing Options page) into water line before machine's incoming water connection point. If water hardness tests at lower than 3 GPG, install water supply line directly to machine's incoming water connection point. Iron in water line can cause staining. A filter designed to remove iron from water supply is highly recommended for supplies in excess of 0.1 ppm.

PLUMBING



The manufacturer does NOT endorse "Tankless On-demand" water heaters for use with their dishmachines. The manufacturer DOES endorse, and highly recommends, the standard "Tank" style water heaters, sized to properly handle the water heating requirements of the facility.

The manufacturer has an optional water pressure regulator (**supplied on ER units only**) to accommodate areas where water pressure fluctuates or is higher than the recommended pressure (see Plumbing Options page). The machine uses a flow pressure of 20 ± 2 PSI for the incoming water line. Do not confuse static pressure with flow pressure. Static pressure occurs when there is no flow and the valves are closed. Flow pressure occurs when water is running into the machine. Pressure regulator should be adjusted to proper flow pressure indicated on the data plate.

Water supply line must be 1/2" NPT minimum and must be able to provide water at minimum temperature indicated on machine data plate. A shut-off valve (**not supplied**) should be installed to isolate machine from water system in the event service is required. An optional shock absorber (**not supplied**) should also be installed on the incoming water line (see Plumbing Options page). This prevents water hammer (hydraulic shock) from causing damage to the equipment.

See Connection Points section for more information on plumbing connections.

DRAIN LINE CONNECTION

The machine has a gravity-discharge drain. All piping to machine drain must be a minimum 1 1/2" NPT and must not be reduced. There must be a minimum 1 1/2" air-gap between machine drain line and floor drain or sink. Floor drain or sink must be a minimum 3" NPT. If a grease trap is required by code, it should have a flow capacity of 5 GPM. 44" models have one drain connection point and 66" models have two (connected and drained into one facility floor drain or sink).

See Connection Points section for more information on drain line connection.

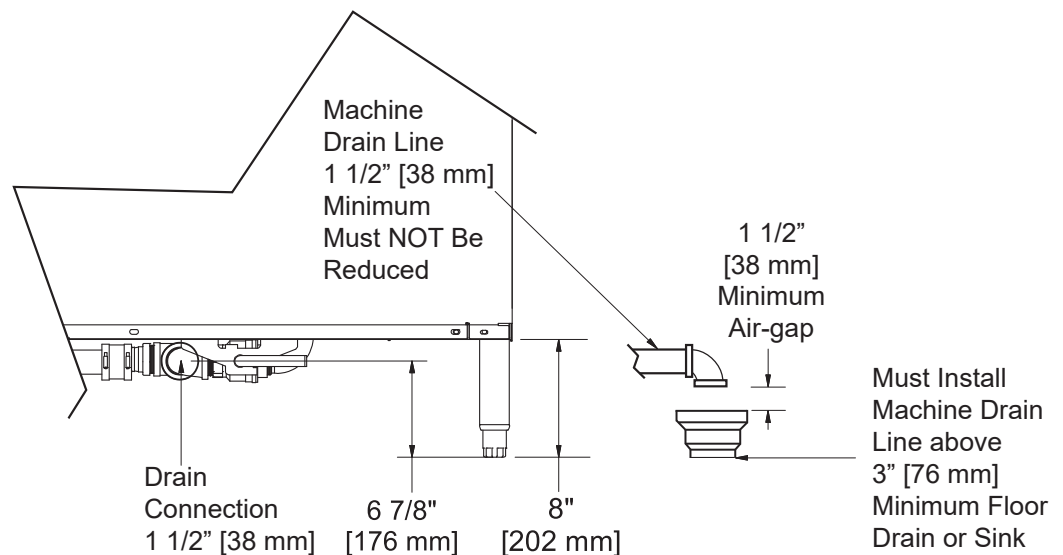

STEAM LINE CONNECTION

Steam models come with lines to connect to source steam. Connect steam lines to the machine as all applicable codes provide. See machine data plate for information concerning steam flow pressure.



Click icon for Steam Booster manual.

ELECTRICAL POWER CONNECTIONS

All electrical connections must be made in accordance with applicable portions of local, state, territorial, and national codes.

Refer to data plate for machine operating requirements, machine voltage, total amperage and serial number.



Disconnect electrical power at the breaker or disconnect switch and tag-out in accordance with procedures and codes.

1. Locate main power terminal blocks (one block each for machine and booster heater for dual-point, one block for single-point) at top of machine.
2. Remove top cover to access terminal blocks.
3. Route incoming power lines within conduit that will connect via fittings to pre-punched holes in back of control box.
4. Install power and ground wires to lugs as indicated by appropriate decals in control box. Use copper conductors only. Use of an anti-oxidation agent is permissible on power connections.

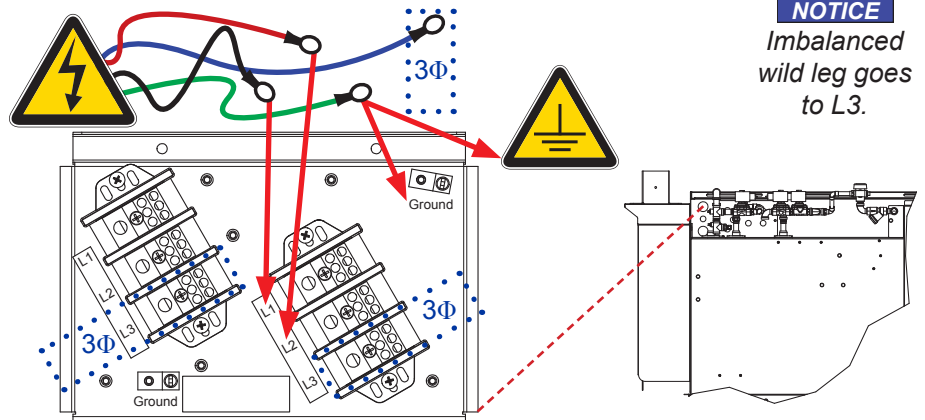

5. Tighten all connections.
6. Verify incoming voltage matches voltage indicated on data plate.



NOTICE For dual-point connection, machine has a separate power connection from the rinse booster heater and the circuit protection requirements are different for each. Refer to the machine data plate for information on minimum circuit protection.



CAUTION! Improperly connecting external devices can cause damage to the machine and/or electrical infrastructure! See the External Device Wiring section.

MOTOR ROTATION

On 3-Phase machines only, correct pump motor rotation must be verified before the machine is operated. Failure to do so can result in damage to the machine and components.

1. Follow "Power Up" section.
2. Remove front panel of machine.

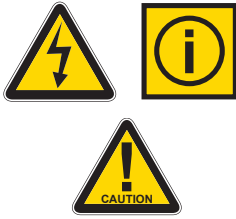

CAUTION! On 3-Phase machines only, correct pump motor rotation must be verified before operation!

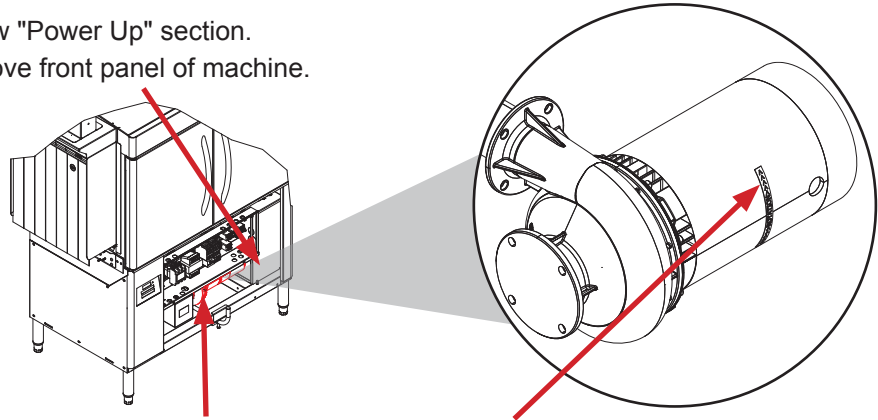

3. Locate wash pump motor and identify arrow decal which shows correct motor rotation (if no decal is present, correct rotation is toward back of machine).
4. Push delime button on display.
5. Observe rotation of motor and quickly push delime button again.
6. If rotation is incorrect, disconnect electrical power and reverse L1 and L2 connections at terminal block shown in previous section.

VENTILATION

The machine should be located with an adequate exhaust hood or ventilation system with provisions for venting. This is essential to permit efficient removal of condensation exhaust. Ensure the exhaust system is acceptable in accordance with applicable codes and standards.



CAUTION! ER models must use vents, not a hood!

NOTICE Any damage caused by steam and/or moisture due to improper ventilation is NOT covered under the warranty.

Dishmachine ventilation requirements:

- **Load End: 200 CFM**
- **Unload End: 200 CFM**

The exhaust system must be sized to handle this volume for the machine to operate properly.

THERMOSTATS

Thermostats on this machine have been set at the factory for the wash tank and should only be adjusted by an authorized service agent.

TABLE LIMIT SWITCH OPTION

There are two Table Limit Switch options available. See Miscellaneous/Options page for ordering information. Click on icons below for install guides.

Striker Switch



Whisker Switch



CHEMICAL FEEDER EQUIPMENT



WARNING! Some chemicals used in dishwashing can cause chemical burns if they come in contact with skin. Wear protective gear when handling these chemicals. If any skin comes in contact with these chemicals, immediately follow the instructions provided with the chemicals for treatment.

This machine does not come with an integral chemical supply/feeder system and must be connected to a third-party chemical dispenser (see Connection Points section) that meets the requirements of NSF Standard 29. Contact a chemical supplier about connecting a dispenser to the machine. Chemical dispensers must be set for the type and concentration of chemicals being used.

Detergent usage and water hardness are two factors that contribute greatly to how efficiently the machine will operate. Using the proper amount of detergent can be a source of substantial savings. A qualified water treatment specialist can explain what is needed to gain the maximum efficiency from detergent.

See Connection Points section for more information on chemical connections.

CONNECTION POINTS

L-R unit shown.

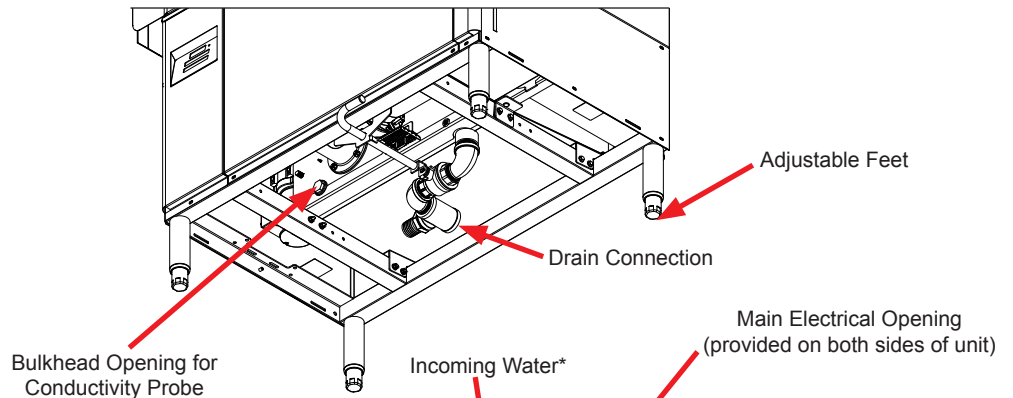

L-R unit shown.

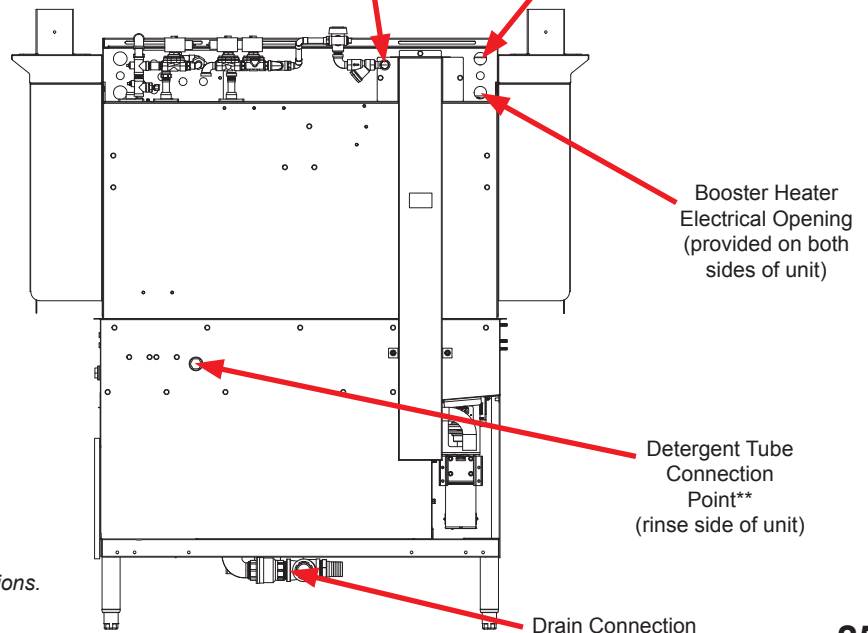

*See next page for details.
 **See next page for rinse-aid and sanitizer tube connections.

CONNECTION POINTS

L-R units shown.

Water connections shown to the right.

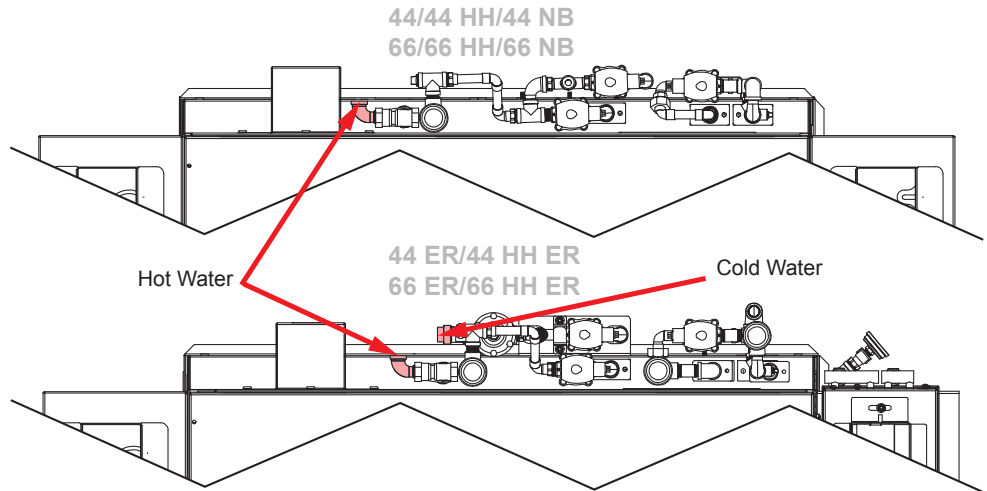

L-R unit shown.

Rinse-aid and sanitizer tube connections shown to the right.

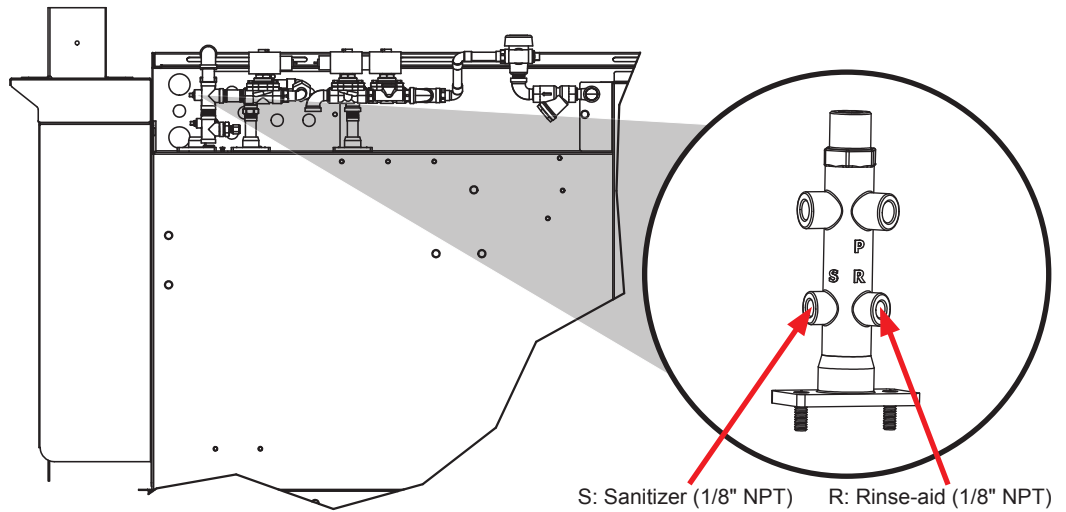

S: Sanitizer (1/8" NPT) R: Rinse-aid (1/8" NPT)

L-R unit shown.

View of machine to the right is a top view with the panel removed.

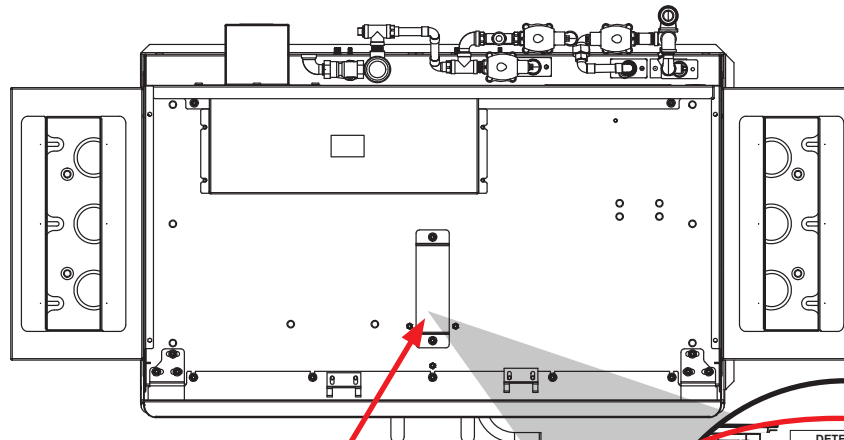

Fuse Block

Rinse-aid and detergent dispenser connections shown to the right.

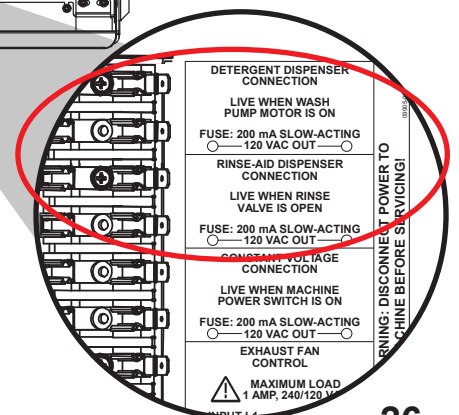

DETERGENT DISPENSER CONNECTION
LIVE WHEN WASH PUMP MOTOR IS ON
FUSE: 200 mA SLOW-ACTING 120 VAC OUT

RINSE-AID DISPENSER CONNECTION
LIVE WHEN RINSE VALVE IS OPEN
FUSE: 200 mA SLOW-ACTING 120 VAC OUT

CONSTANT VOLTAGE CONNECTION
LIVE WHEN MACHINE POWER SWITCH IS ON
FUSE: 200 mA SLOW-ACTING 120 VAC OUT

EXHAUST FAN CONTROL

MAXIMUM LOAD 1 AMP, 240/120 V

EXTERNAL DEVICE WIRING



Click icon for external device (exhaust fan, etc.) wiring instructions. They can also be accessed by navigating to them on our website. Follow the instructions carefully when wiring any external device.

EXHAUST FAN TIMER



Click icon for instructions on programming the exhaust fan timer. The instructions can also be accessed by navigating to them on our website.

CURTAINS

The machine has decals marking curtain locations, starting at load end and ending at unload end. The illustrations below indicate the curtain size to be placed on curtain hooks provided. If any curtain components are missing, they must be obtained and installed before operation. The machine will be configured for either Left-to-Right or Right-to-Left operation. Direction is from load end to unload end, as shown below.

Curtains must be installed properly for machine to operate correctly. Curtains are used to control air currents inside the machine and assist in maintaining the heat necessary to keep energy costs down.

Low Hood

44

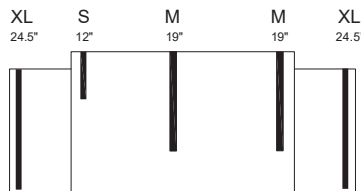

High Hood

44

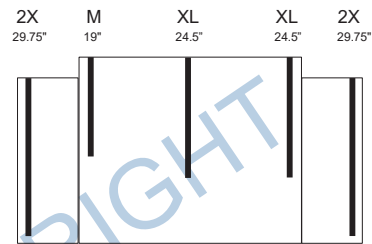

66

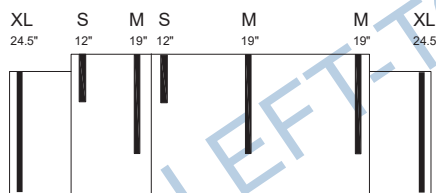

66

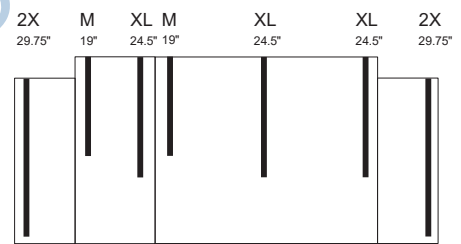

CAUTION! When side-loader option is present, there are different part numbers for curtain and rod for load end of machine.

XL
24.5" L x 24.19" W

Side-loader

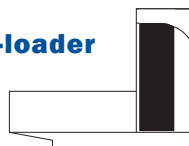

2X
29.75" L x 24.19" W

Side-loader

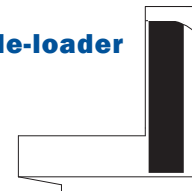

| Legend | Length | Part # |
|--------|--------|-----------------|
| S | 12" | 08415-131-73-44 |
| M | 19" | 08415-002-14-41 |
| XL | 24.25" | 08415-002-47-37 |
| 2X | 29.75" | 08415-004-49-64 |
| Rod | 20.50" | 05700-003-77-52 |

| Side-loader Option | Part # |
|--------------------|-----------------|
| XL (Load End) | 08415-003-84-88 |
| 2X (Load End) | 08415-004-69-54 |
| Rod (Load End) | 05700-003-84-57 |

PREPARATION Before operating machine, verify:

- Strainers are installed.

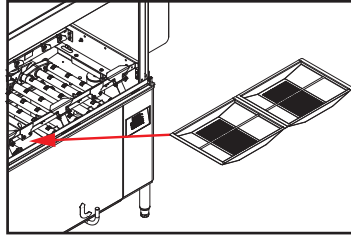

- Drain valve is closed.

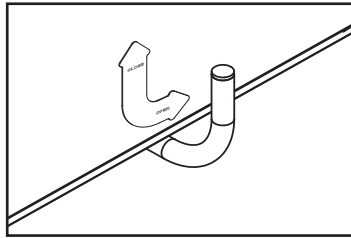

- Actuator switches move with relative freedom and do not bind.

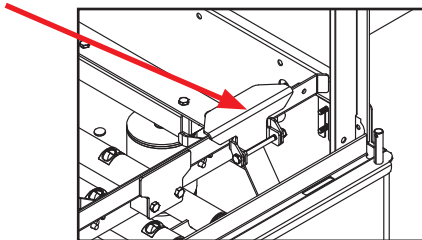

- Curtains are installed correctly.

POWER UP To place the machine in standby, press power button on display.

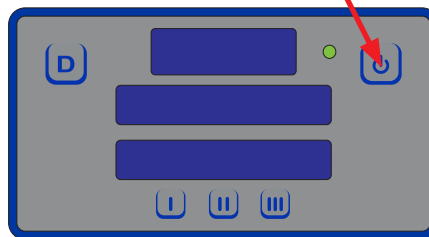

1. Machine automatically checks for proper water level in wash tank. If not, machine will begin to fill until appropriate level is reached.
2. If wash tank temperature is not at minimum level for mode of operation, wash heater will energize. Refer to machine data plate for minimum temperatures needed to operate machine correctly. It might take several minutes for the wash tank to heat up, depending on initial temperature of the water.
3. If machine is equipped with a booster heater, the booster will turn on when machine turns on.
4. If machine is heated with a steam booster, the steam booster must be turned on in accordance with its manufacturer's instructions.
5. Do not attempt to start machine until:
 - a. Filling stops.
 - b. Appropriate wash tank temperature is reached.

FIRST RACK

The first rack of ware can reduce the temperature of the wash tank and might need to be run through again. This might be necessary any time the machine has not been operated for an extended period of time, although this is dependent on the type of ware being used, its temperature, and the ambient temperature of the kitchen area. To ensure proper operation, always observe wash and rinse temperatures when first starting machine.

WARE PREPARATION

Proper preparation of ware is essential for the smooth, efficient operation of this machine. Any ware placed in the machine should have all solid food waste and scraps removed. Ware should also be sprayed-down before entering the machine.

Place cups and glasses upside-down in racks so they don't hold water during the cycle. Pre-soak flatware in warm water to help remove food. Load plates and saucers in the same direction, with the food surface facing the unload end of the machine.

WASHING A RACK OF WARE

This machine is designed to wash ware placed in a rack. Ware should not be placed in the machine unless it is properly secured in a dish rack.

To start a cycle, gently push rack into the machine on the load end. Once the wash actuator has moved sufficiently, the machine will automatically begin to convey the dish rack through the machine. The entire cycle is automatic.

TURBO RINSE

Turbo Rinse option is a longer rinse, ensuring optimal rinse and sanitization.

1. To select Turbo Rinse option, press and hold III button for three seconds.

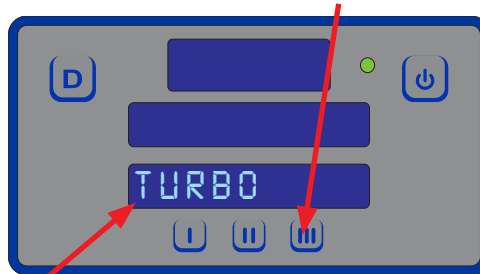

2. Display will show "Turbo."
3. Press and hold I button for three seconds to revert to Econo Rinse. Machine reverts to Econo Rinse (default) when turned off.

OPERATIONAL INSPECTION



Operators should periodically review the following items while the machine is operating. These items are important for operating the machine efficiently.

- Review wash and rinse temperatures and compare to minimums on data plate.
- Verify pan strainers are not becoming clogged. Keeping these free of soil and debris allows better water flow through machine and helps prevent redeposit issues.
- Machine is designed to run at a 20 ± 2 PSI. Any lower and there will not be enough rinse water to properly remove detergent from the ware.
- Wash and rinse arm nozzles should be free of debris. Open nozzles are essential to the operation of the machine.

SHUTDOWN & CLEANING

1. Press power button to shutdown machine.
2. Open access door and allow steam/heat to escape.
3. Turn drain handle to OPEN and allow tub to drain.



WARNING! Wash tank water will be hot.

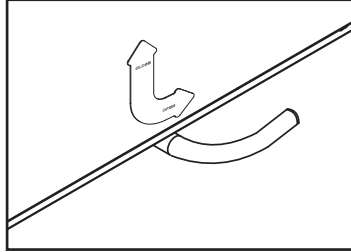

4. Remove strainers, hand-scrape foodsoil into trash, and spray with pre-rinse hose.

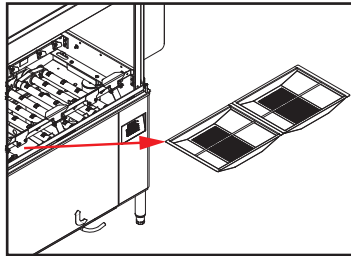

5. Rinse float switch off, rinse tank out, and inspect tank for debris.

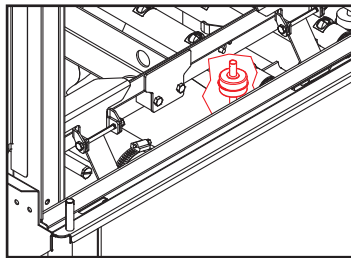

6. Remove curtains, scrub with mild detergent and brush and air-dry.

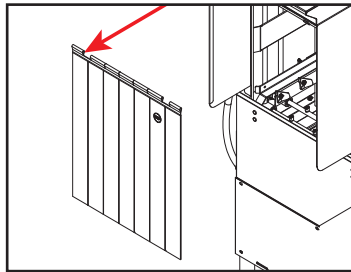

7. Wash & Rinse Arms:

- a. As needed, fill tub with water.
- b. Remove end-caps from arms.
- c. Run an empty rack through machine.
- d. If necessary:
 - i. Clean nozzles with a brush.
 - ii. Use a small wire or toothpick to remove remaining debris/lime deposits from the nozzles.
 - iii. Flush arms with water.
 - iv. Replace end-caps and securely tighten.

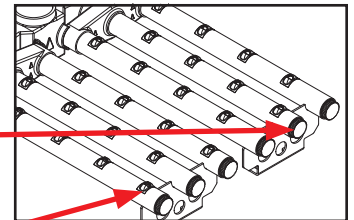

Self-cleaning arms do not require daily cleaning.

SHUTDOWN & CLEANING

8. Spray or wipe out interior of machine.

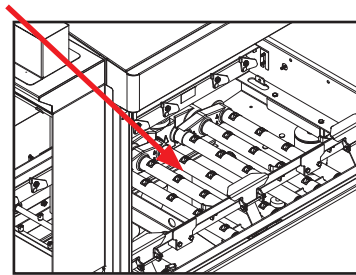

9. Ensure curtains, rinse arms, strainers, and wash arms are clean and securely in place.

10. Use stainless steel polish to clean and protect outside of machine.

DISPLAY INSTRUCTIONS

Checking Cycle Count

- While machine is powered off, press and hold power button. Total cycle count will display for several seconds, followed by a normal .ON state.

General

1. When main power is first connected to machine, display sequences through its LEDs to show all are functional.
2. Machine then goes into Standby Mode (blank display).
3. Press power button.
4. Display shows "Heating" until wash tank reaches operating temperature.

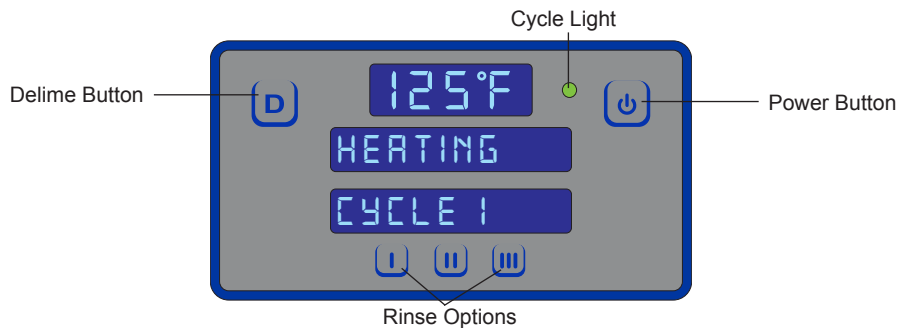

5. Display shows "Ready" when machine is ready to use.

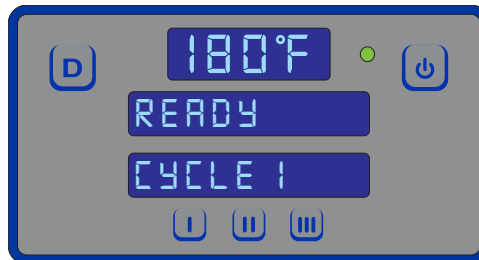

DISPLAY INSTRUCTIONS

Operational Messages

| DISPLAY | CONDITION |
|---------------------------------------|--|
| "Check doors" | A door is not fully closed or a switch is not being triggered. |
| "Filling" | Wash tank is filling with water. |
| "Heating" | Wash tank is heating. |
| "Delime" | Delime button has been pressed. |
| "Ready" | Machine is ready for operation. |
| "Wash Temp" | Rack of ware is progressing through wash section. |
| Alternates "Wash Temp" & "Rinse Temp" | Rack of ware is progressing through rinse section. |

DELIME INSTRUCTIONS



WARNING! Deliming solution can cause chemical burns. Follow instructions provided with deliming solution.

This equipment is not recommended for use with deionized water or other aggressive fluids. Use of deionized water or other aggressive fluids will result in corrosion and failure of materials and components. Use of deionized water or other aggressive fluids will void the manufacturer's warranty.

Consult chemical supplier's instructions before deliming machine.

1. Disconnect or turn-off chemical feeder pumps.
2. Turn machine power off and drain machine.
3. Ensure machine is clean and all parts are in place.
4. Ensure doors are closed and press power button to begin filling.
5. Fill machine with correct amount of delime solution as recommended by chemical supplier.
6. Wash tank holds 25 gallons and pre-wash tank holds 15.8 gallons.

After chemicals are added:

7. Ensure doors are closed.
8. Press delime button and run machine length of time recommended by chemical supplier.
9. Press delime button again to stop deliming process.

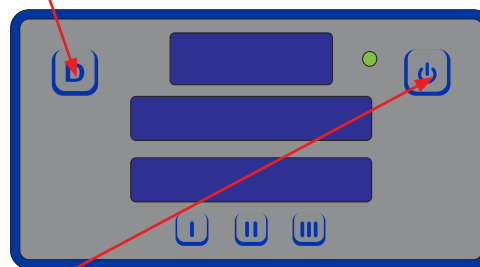

10. Press power button to shut machine off.
11. Wait five minutes, open doors and inspect inside of machine. If machine is not delimed, drain and re-fill machine, then repeat steps 5–10.
12. When deliming is complete, drain and re-fill machine. Then run machine two cycles to remove residual deliming solution.
13. Drain and re-fill machine.
14. Re-connect chemical feeder pumps.
15. Machine is ready to use.

**PREVENTATIVE
MAINTENANCE**

Manufacturer highly recommends any maintenance and repairs not specifically discussed in this manual be performed only by QUALIFIED SERVICE PERSONNEL. Unqualified personnel performing maintenance may void the warranty, lead to larger problems, or cause harm to the operator. Contact a QUALIFIED SERVICE AGENCY with any questions or concerns.

Following operating and cleaning instructions in this manual results in the most efficient results from the machine. As a reminder, here are some steps to ensure the machine is being used how it was designed to work:



1. Ensure water temperatures match those listed on machine data plate. There can be a variety of reasons why water temperature could be too low.
2. Ensure all strainers are clean and in place, laying flat, before operating machine. When cleaning out strainers, do NOT beat on waste cans. Wipe out strainers with a rag and rinse under a faucet if necessary. Use a toothpick to dislodge any stubborn debris.
3. Ensure all wash and rinse arms are secure in machine before operating.
4. Ensure drains are closed before operating.
5. Remove as much soil as possible from ware before loading into racks.
6. Do not overfill racks.
7. Ensure glasses are placed upside-down in the rack.
8. Ensure all chemicals have been verified at the correct concentrations.
9. Clean machine every 24 hours or at end of workday per instructions in this manual.
10. Follow all safety procedures, whether listed in this manual or put forth by local, state, or national codes/regulations.



WARNING! Inspection, testing, and repair of electrical equipment should only be performed by a qualified service technician. Many tests require unit have power to it and live electrical components exposed. USE EXTREME CAUTION WHEN TESTING MACHINE.

| OBSERVATION | POSSIBLE CAUSE | REMEDY |
|---|---|--|
| Machine will not fill after door is closed. Power "ON" light is illuminated. | <ol style="list-style-type: none"> 1. Faulty rinse solenoid valve. 2. Faulty door switch. | <ol style="list-style-type: none"> 1. Repair or replace valve as required. 2. Verify wiring of switch; if correct, replace switch. |
| Machine will not fill after door is closed. Power "ON" light is NOT illuminated. | <ol style="list-style-type: none"> 1. Service breaker tripped. 2. Machine not connected to power source. 3. Faulty power source. | <ol style="list-style-type: none"> 1. Reset; if breaker trips again, contact an electrician to verify amp draw of machine. 2. Verify machine has been properly connected to power source. 3. Verify working power source. |
| Machine will not run after door is closed. Power "ON" light is illuminated and unit is filling. | <ol style="list-style-type: none"> 1. Wash motor faulty/damaged. 2. Wash motor contactor faulty. | <ol style="list-style-type: none"> 1. Verify wash motor is getting power; if so, replace motor. 2. Check for continuity; if contacts are open, replace contactor. |
| Machine runs continuously in wash cycle. | Machine is in Delime mode. | Select an automatic cycle by choosing I or II on display. |
| Wash heater does not work. | <ol style="list-style-type: none"> 1. Faulty heater element. 2. Faulty heater contactor. | <ol style="list-style-type: none"> 1. Check element for continuity; if open, replace heater. 2. Replace contactor. |
| Machine fills slowly and/or rinse is weak. | <ol style="list-style-type: none"> 1. Clogged or obstructed rinse arms. 2. Low incoming water pressure. 3. Y-strainer is clogged | <ol style="list-style-type: none"> 1. Remove and clean rinse arms. 2. Adjust water pressure regulator to ensure 15 PSI flow. 3. Clean out Y-strainer. |



WARNING! Inspection, testing, and repair of electrical equipment should only be performed by a qualified service technician. Many tests require unit have power to it and live electrical components exposed. USE EXTREME CAUTION WHEN TESTING MACHINE.

| OBSERVATION | POSSIBLE CAUSE | REMEDY |
|---|---|--|
| No indication of pressure. | <ol style="list-style-type: none"> 1. Water turned off. 2. Pressure transducer disconnected. 3. Pressure transducer defective. | <ol style="list-style-type: none"> 1. Turn water on. 2. Verify wiring. 3. Replace pressure transducer. |
| Wash water not reaching required temperature. | <ol style="list-style-type: none"> 1. Faulty wash heater. 2. Wash thermometer is defective. | <ol style="list-style-type: none"> 1. Check element for continuity; if open, replace heater. 2. Replace thermometer. |
| Doors will not close completely. | <ol style="list-style-type: none"> 1. Obstruction in door channel. 2. Machine not level. | <ol style="list-style-type: none"> 1. Remove obstruction. 2. Adjust feet to level machine. |
| Water leaks at wash pump. | <ol style="list-style-type: none"> 1. Wash pump seal defective. 2. Pump drain hose not tight. 3. Loose hoses (hose clamps) on wash pump. | <ol style="list-style-type: none"> 1. Replace seal. 2. Tighten. 3. Tighten hose clamps. |
| Will not rinse. | <ol style="list-style-type: none"> 1. Defective rinse solenoid. 2. Faulty timer. 3. No water to machine. | <ol style="list-style-type: none"> 1. Repair or replace rinse solenoid. 2. Replace timer. 3. Verify water at 15 PSI is connected to machine. |
| Dishes are not coming clean. | <ol style="list-style-type: none"> 1. Machine temperatures are not at minimum requirements. 2. No detergent or too much detergent. | <ol style="list-style-type: none"> 1. Verify incoming water, rinse water, and wash water match required temperatures listed on machine data plate. 2. Adjust detergent concentration as required for amount of water in machine. |

SETUP MODE *To access setup mode, machine should be on and not in operation (accessing this mode during operation will interrupt the process).*

1. Press and hold up-arrow and down-arrow buttons until "Setup" starts flashing (2-3 seconds).

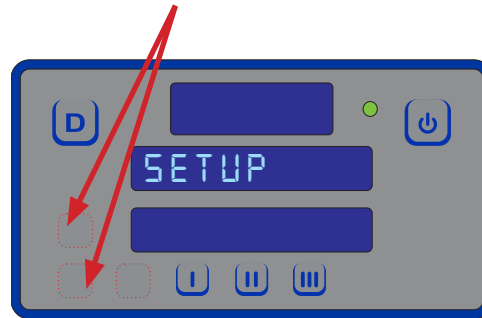

2. Display then changes to "Version" and shows firmware versions.
3. Use up-arrow button to cycle through categories (will be flashing).
 - Language
 - Temperature Scale
 - Wash Temperature
 - Boost Temperature
 - Wash Offset
 - Rinse Offset
 - Boost Offset
 - Spare Offset

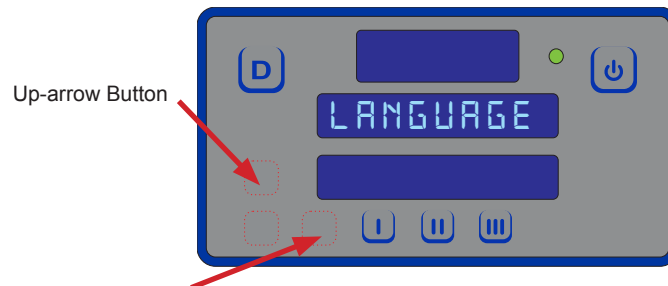

4. Press select button to choose category.
 - Regardless of category, Steps 5-7 remain the same.
5. Use up-arrow button to change options (will be flashing). Numerical options are shown in top window.

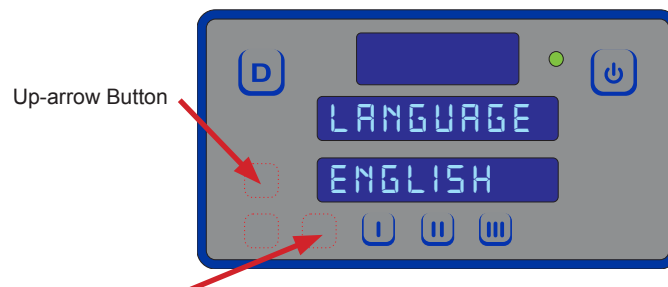

6. Press select button to accept changes.
7. Press delime button to exit.

| DISPLAY SHOWS | POSSIBLE CAUSES | REMEDY |
|---|---|---|
| "F4 Service needed,"
"Check incoming power" | <ol style="list-style-type: none"> Incoming power not properly connected. L3 is missing (3-phase units only). | <ol style="list-style-type: none"> Check connections to heater. Verify L3 is present and connected properly. |
| "F6 Service needed,"
"No water in wash tank" | <ol style="list-style-type: none"> Low or no water pressure. Faulty inlet valve or fill relay. Contact to wash heater not turning off. Faulty temperature input (T1) on IO module. Faulty temperature probe (T1). Faulty float switch allows heaters to operate with no water in tub. | <ol style="list-style-type: none"> Verify incoming water pressure is 15 PSI. Verify fill relay is supplying voltage to fill solenoid. Replace faulty component. Check for welded contacts. Verify output from IO module turns off when above set temperature. Substitute a 1.2 kΩ resistor for T1, and verify wash heater turns off. If not, replace IO module. Verify T1 resistance is correct with respect to temperature (see table on next page). If not, replace T1. Replace float switch. |
| "F7 Service needed,"
"Check wash tank thermostat" | <ol style="list-style-type: none"> Contact to wash heater not turning off. Faulty temperature input (P10) on IO module. Faulty temperature probe (T1). | <ol style="list-style-type: none"> Check for welded contacts. Verify output from IO module turns off when above set temperature. Substitute a 1.2 kΩ resistor for T1, verify wash heater turns off. If not, replace IO module. Verify T1 resistance is correct with respect to temperature (see table on next page). If not, replace T1. |
| "F8 No water in wash tank,"
"Check inlet water and door" | <ol style="list-style-type: none"> Malfunction of fill solenoid or fill relay. Door is open, which inhibits fill mode. Faulty door switch. | <ol style="list-style-type: none"> Replace faulty solenoid or fill relay. Close door to activate door switch. Replace or adjust door switch. |
| F11 Service needed
—check wash tank thermostat | Faulty temperature probe (T1). | Replace probe that connects to P10. |
| F12 Service needed —
check booster thermostat | Faulty temperature probe (T3). | Replace probe that connects to P13. |
| F13 Communication error. Check 6-pin cable | <ol style="list-style-type: none"> Loose connection in 6-pin cable between display board and IO module. Faulty 6-pin cable between display board and IO module. Faulty communication port on IO module or display board. | <ol style="list-style-type: none"> Fully disconnect 6-pin cable at each end and reconnect each end until a click is heard. Inspect for broken wire or unseated terminal by gently pulling on each wire at each end of the cable. Reseat any loose terminals by inserting fully into housing using long-nosed pliers. Replace cable if broken wire is found. Temporarily substitute a verified good display board, and check if F13 message recurs. If so, replace with a good IO module. |

RESISTANCE-TO-TEMPERATURE VALUES

| R (k Ω) | °F |
|-----------------|-------|
| 11.58 | 69.8 |
| 10.37 | 75.2 |
| 9.30 | 80.6 |
| 7.78 | 89.6 |
| 3.05 | 140.0 |
| 2.54 | 150.8 |
| 2.18 | 159.8 |
| 1.58 | 179.6 |
| 1.45 | 185.0 |
| 1.33 | 190.4 |
| 1.16 | 199.4 |
| 0.96 | 212.0 |

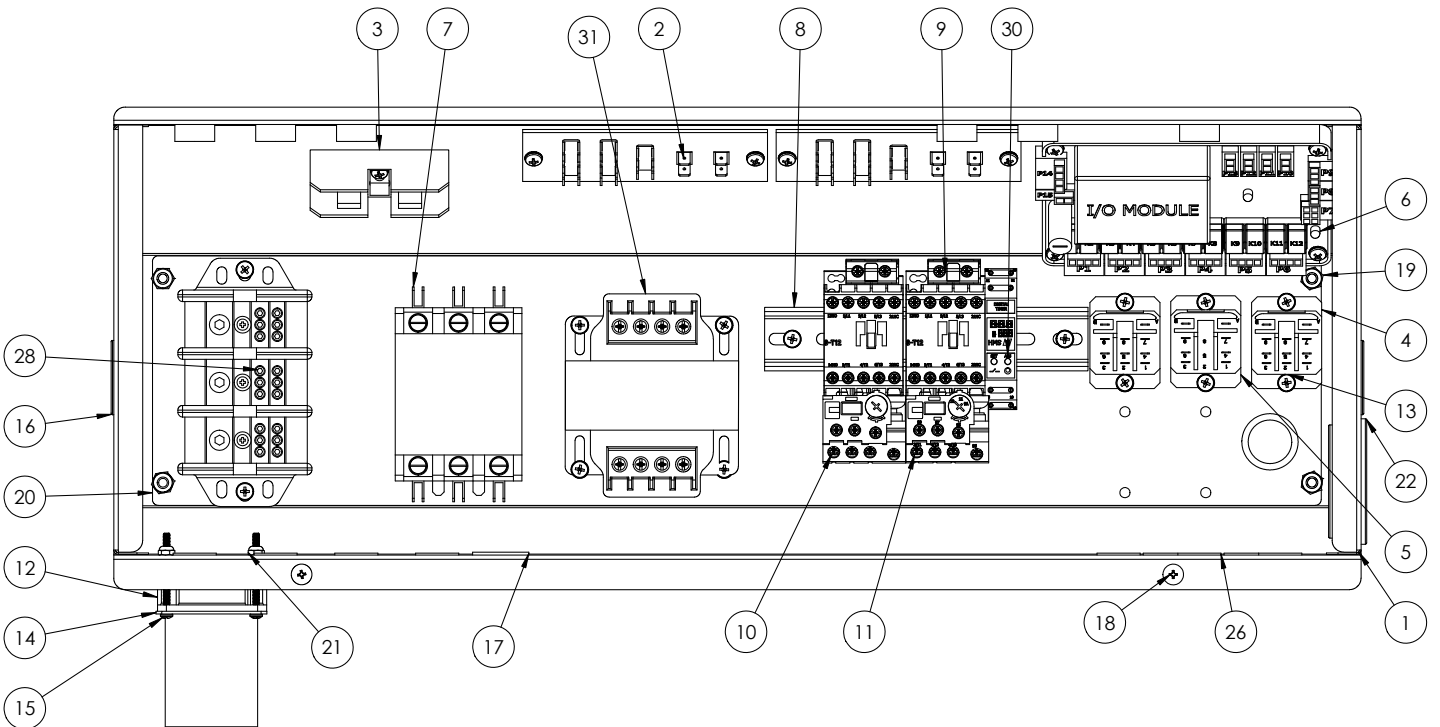
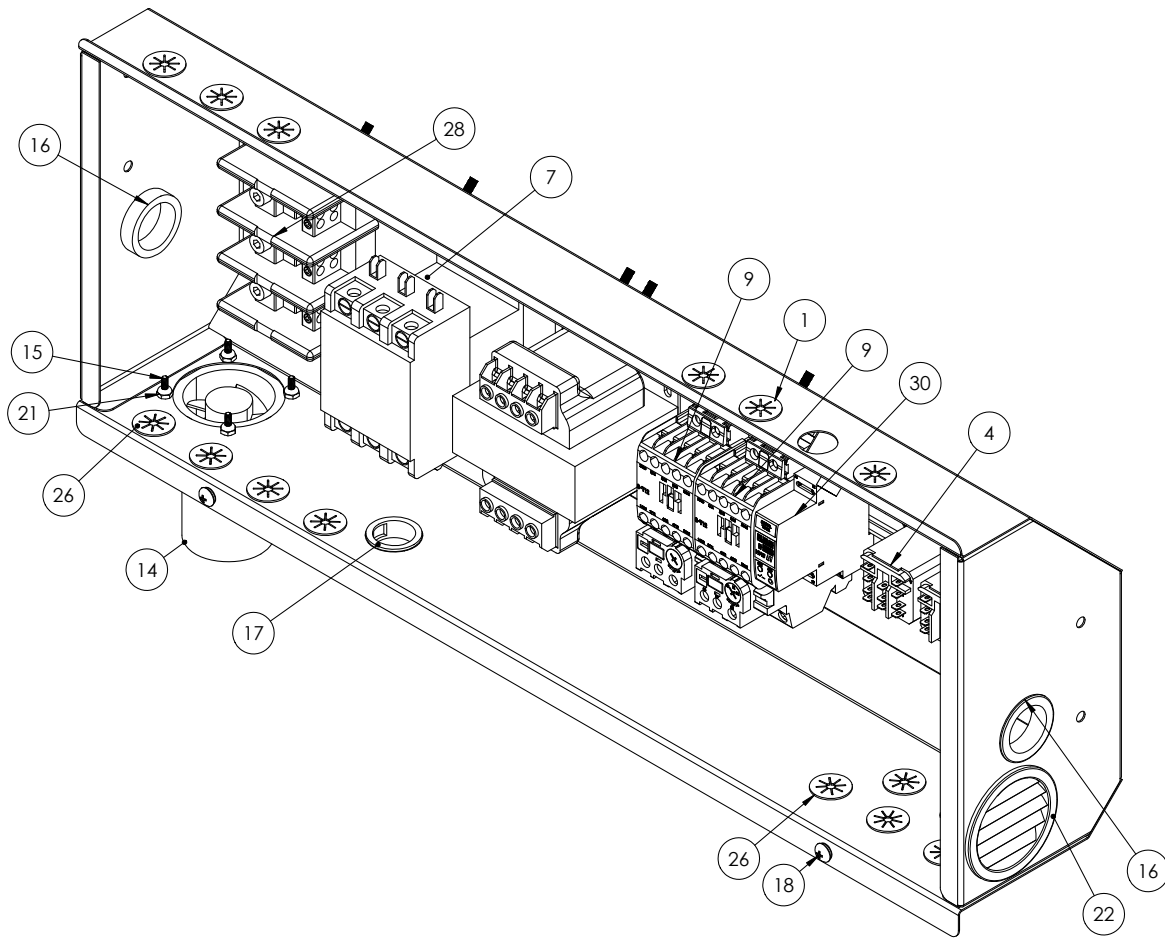

| ITEM | QTY | DESCRIPTION | PART NUMBER |
|------|-----|--|--|
| 1 | 1 | Control Box | 05700-004-18-66 |
| 2 | 2 | Terminal Board | 05940-002-78-97 |
| 3 | 1 | Fuse Holder | 05920-011-72-89 |
| 4 | 2 | Relay | 05945-111-72-51 |
| 5 | 1 | Relay | 05945-111-35-19 |
| 6 | 1 | I/O Module | 05945-005-16-45 |
| 7 | 1 | Contactora, 3-pole, 50 A (3-phase)
Contactora, 4-pole, 50 A (1-phase) | 05945-002-24-70
05945-111-68-37 |
| 8 | 1 | Din Rail | 05700-003-71-06 |
| 9 | 2 | Contactora, 13 A | 05945-004-25-79 |
| 10 | 1 | Overload | See Motor Overloads page. |
| 11 | 1 | Overload | See Motor Overloads page. |
| 12 | 1 | Fan | 05999-004-30-62 |
| 13 | 25 | Screw, 10-32 x 1/2 | 05305-002-32-37 |
| 14 | 1 | Vent Tube, Fan | 05700-004-33-78 |
| 15 | 4 | Screw, 6-32 1 3/4 | 05305-004-36-67 |
| 16 | 2 | Bushing, Snap | 05975-003-10-46 |
| 17 | 2 | Bushing, Snap | 05975-210-08-00 |
| 18 | 2 | Screw, 10-32 x 1/2 | 05305-004-43-78 |
| 19 | 4 | Locknut, 1/4-20 with Nylon Insert | 05310-374-01-00 |
| 20 | 1 | Panel, Control Inner | 05700-004-18-67 |
| 21 | 4 | Locknut, 6-32 with Nylon Insert | 05310-373-03-00 |
| 22 | 1 | Plug, Hole | 05975-003-77-39 |
| 23 | 1 | Harness, PSI/Transducer | 05700-004-33-62 |
| 24 | 1 | Cable, Temperature Probe, Wash Tank | 05700-004-33-57 |
| 25 | 1 | Cable, Temperature Probe, Rinse Injector | 05700-004-33-60 |
| 26 | 15 | Grommet, Split | 05975-200-40-00 |
| 27 | 1 | Fuse, 1 A (208/230 V)
Fuse, 1/2 A (460 V) | 05920-002-67-23
05920-011-72-88 |
| 28 | 1 | Terminal Block | 05940-011-48-27 |
| 29 | 1 | Cable, Pressure Sensor | 05700-004-33-61 |
| 30* | 1 | Timer, Universal Digital Multi-timer* | 05945-004-22-78 |
| 31 | 1 | Transformer, 208 V
Transformer, 230/460 V | 05950-011-75-59
05950-011-68-35 |

*Click icon for timer programming instructions.



Complete Display Assembly
05700-004-31-50

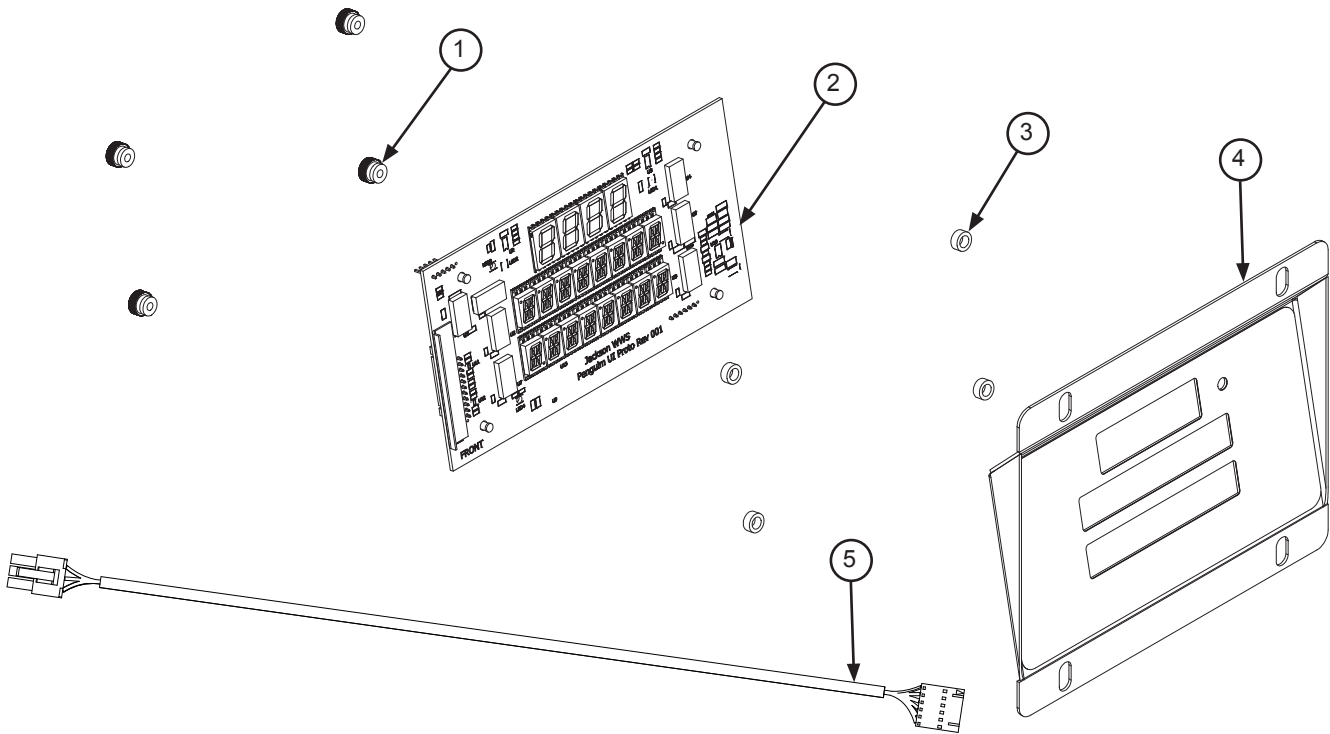

| ITEM | QTY | DESCRIPTION | PART NUMBER |
|------|-----|------------------------------------|---------------------------------|
| 1 | 4 | Nut, Thumb, 6-32 Nylon | 05310-002-83-12 |
| 2 | 1 | Board, Populated Circuit | 05945-004-46-18 |
| 3 | 4 | Spacer, Display Board | 05999-004-19-75 |
| 4 | 1 | Membrane Switch and Panel Assembly | 05700-004-59-65 |
| 5 | 1 | Communication Cable | 05700-004-33-64 |
| | 1 | Cover, Display Board (Not Shown) | 05700-004-35-60 |

Parts are not shown to scale with relation to each other.

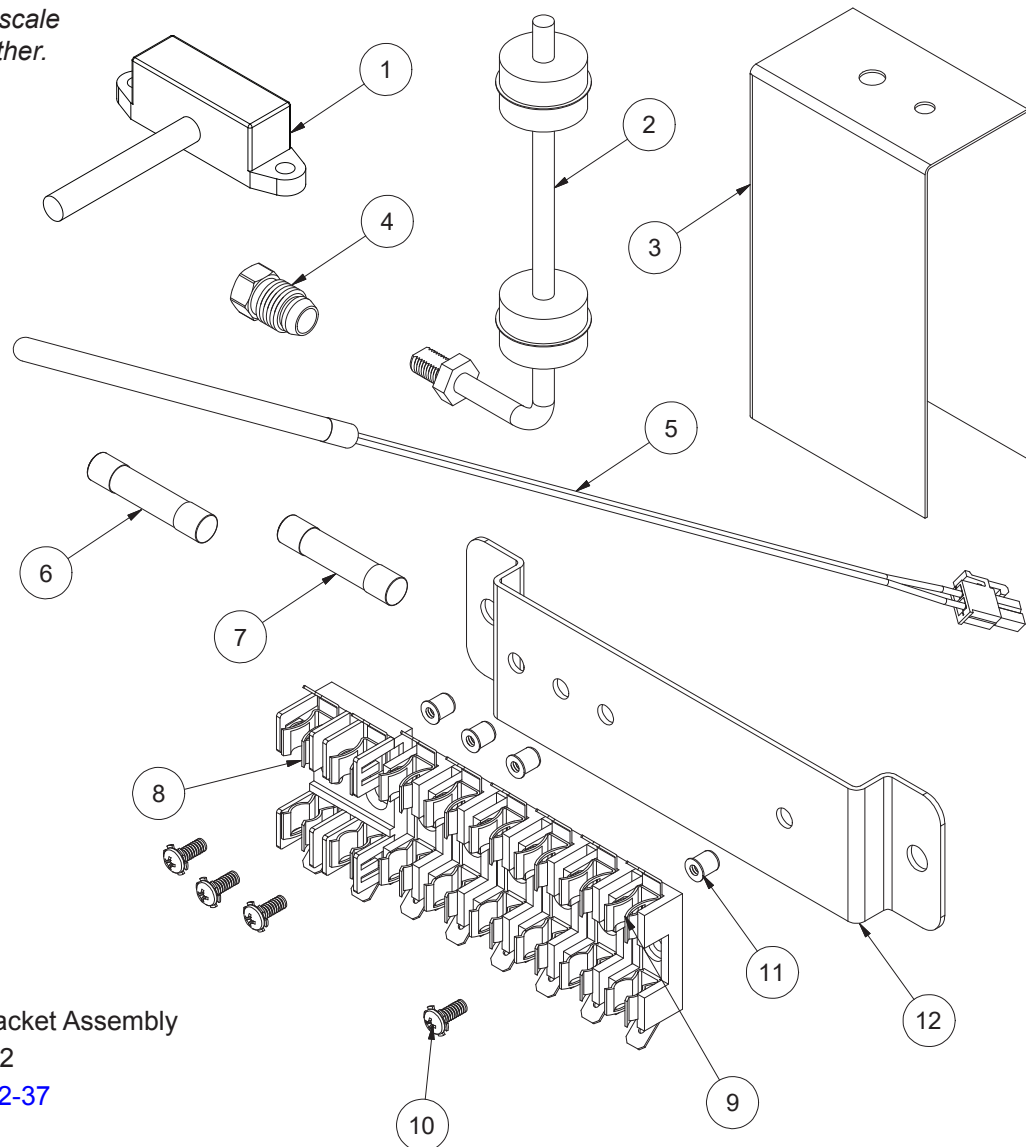

Complete Fuse-strip Bracket Assembly
Items 8–12
[05700-004-32-37](#)

| ITEM | QTY | DESCRIPTION | PART NUMBER |
|------|-----|--------------------------|---------------------------------|
| 1 | 1 | Actuator Switch | 05930-111-68-44 |
| 2 | 1 | Float Switch | 06680-121-70-71 |
| 3 | 1 | Float Switch Cover | 05700-004-71-80 |
| 4 | 1 | Probe Fitting, Brass | 05310-924-02-05 |
| 5 | 1 | Thermistor Probe | 06685-004-34-58 |
| 6 | 6 | Fuse, 200 mA Slow-acting | 05999-004-44-33 |
| 7 | 2 | Fuse, 1 A Fast-acting | 05999-004-47-87 |
| 8 | 1 | Fuse Holder, 2-pole | 05920-401-03-14 |
| 9 | 1 | Fuse Holder, 6-pole | 05920-002-42-13 |
| 10 | 4 | Screw, 6-32 x 3/8" | 05305-002-25-91 |
| 11 | | Fastener, 6-32 | 05340-118-04-00 |
| 12 | 1 | Bracket, Fuse-strip | 05700-004-32-36 |

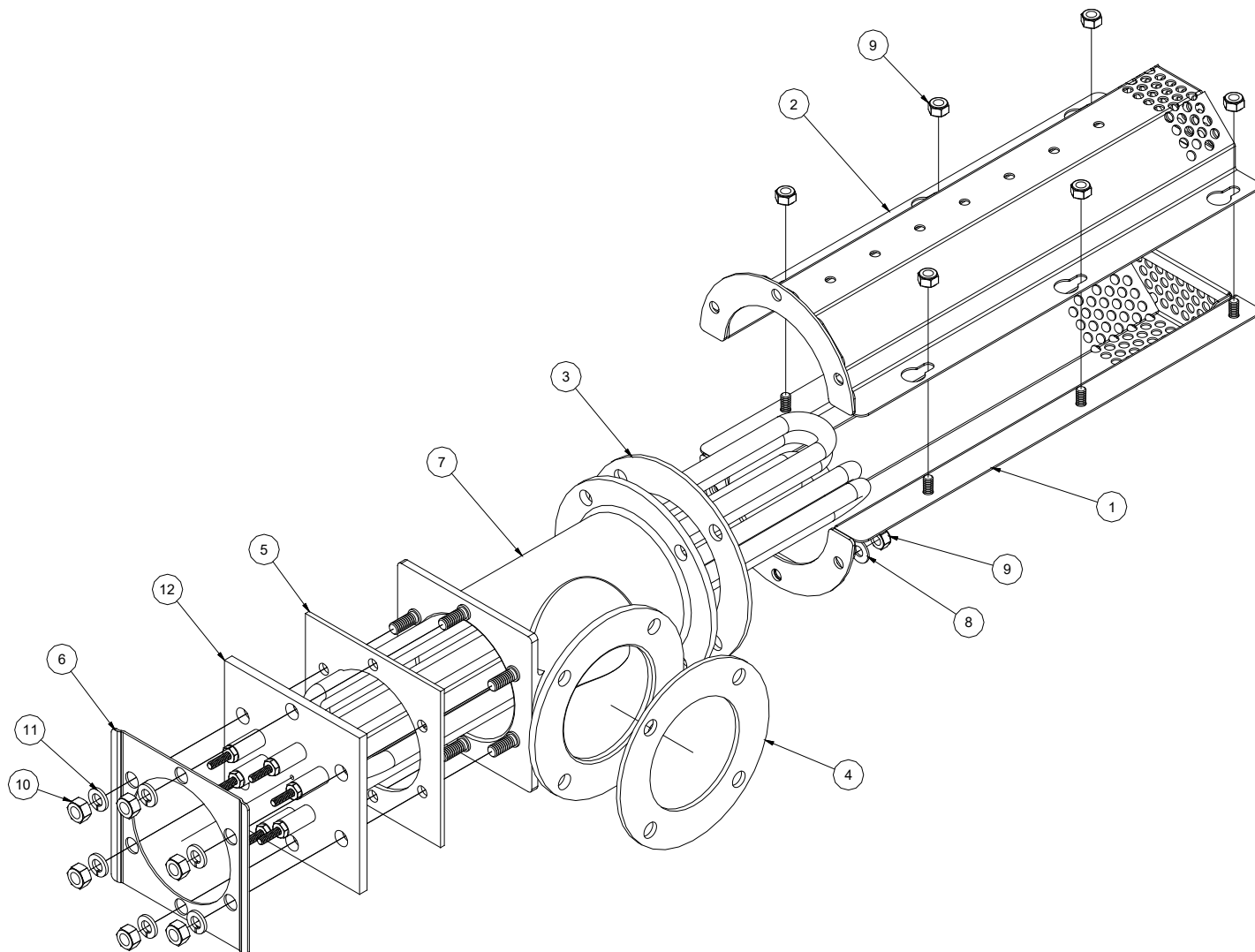

| ITEM | QTY | DESCRIPTION | PART NUMBER |
|------|-----|---------------------------------------|------------------------|
| 1 | 1 | Lower Heater Shroud | 05700-003-74-21 |
| 2 | 1 | Upper Heater Shroud | 05700-003-74-24 |
| 3 | 1 | Gasket, Suction Casting | 05330-003-75-89 |
| 4 | 1 | Gasket, Pump Suction | 05330-003-75-87 |
| 5 | 1 | Gasket, Heater | 05330-200-02-70 |
| 6 | 1 | Heater Box Rails | 05700-003-74-72 |
| 7 | 1 | Wash Pump Suction | 05700-003-77-63 |
| 8 | 2 | Washer, 1/4-20 | 05311-174-01-00 |
| 9 | 9 | Locknut, 1/4-20 Hex with Nylon Insert | 05310-374-01-00 |
| 10 | 6 | Nut, Hex 5/16-18 | 05310-275-01-00 |
| 11 | 6 | Lockwasher, 5/16" Split | 05311-375-01-00 |
| 12 | 1 | Wash Heating Element, 15 kW | See Wash Heaters page. |
| 13 | 1 | Thermostat, High-limit (Not Shown) | 05930-011-49-43 |

| VOLTAGE | PHASE | KW | PART NUMBER | CONTACTOR |
|---------|-------|----|-----------------|-----------------|
| 208 | 1 | 15 | 04540-121-68-45 | 05945-111-68-38 |
| 230 | 1 | 15 | 04540-121-68-46 | 05945-111-68-38 |
| 208 | 3 | 15 | 04540-121-68-45 | 05945-002-24-70 |
| 230 | 3 | 15 | 04540-121-68-46 | 05945-002-24-70 |
| 460 | 3 | 15 | 04540-121-68-47 | 05945-002-24-70 |
| 600 | 3 | 15 | 04540-002-39-93 | 05945-002-24-70 |

NOTICE When replacing wash heaters, it's highly recommended to change the gasket as well. Once installed, gaskets become compressed and are subject to extreme temperature changes. Replacing gasket with heater might prevent future leaks.

Nuts used to secure heater to casting should be torqued to 16 in-lbs. After tightening, machine should be allowed to heat up and operate normally for approximately 30 minutes. Secure power to machine and check nuts once more to verify they are torqued to 16 in-lbs.

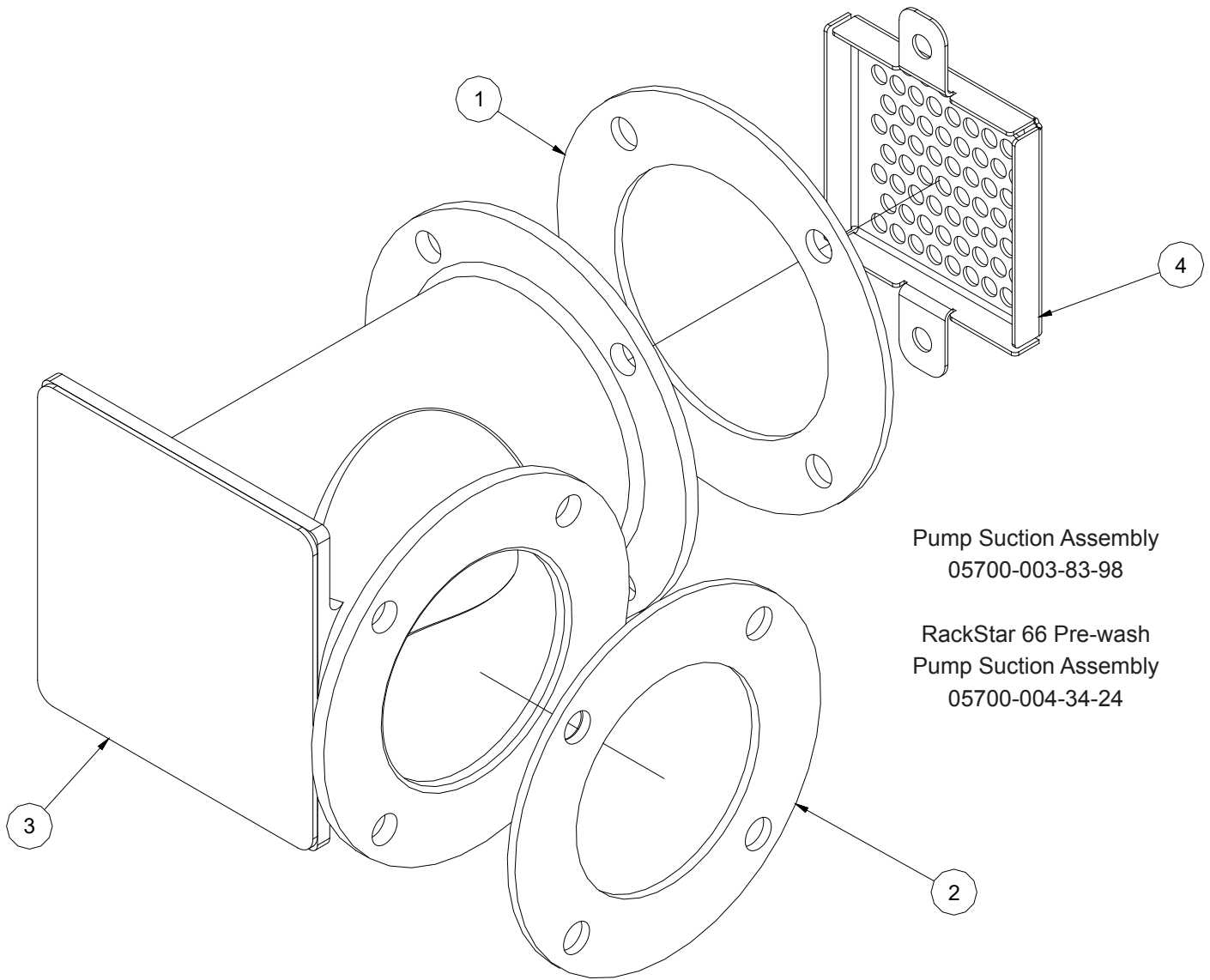

Pump Suction Assembly
05700-003-83-98

RackStar 66 Pre-wash
Pump Suction Assembly
05700-004-34-24

| ITEM | QTY | DESCRIPTION | PART NUMBER |
|------|-----|--------------------------------|---------------------------------|
| 1 | 1 | Gasket, Suction Casting | 05330-003-75-89 |
| 2 | 1 | Gasket, Pump Suction | 05330-003-75-87 |
| 3 | 1 | Pre-wash Pump Suction Weldment | 05700-003-82-27 |
| 4 | 1 | Strainer, Pre-wash Pump | 05700-003-81-28 |

Complete Inlet Plumbing Assembly, L-R

05700-004-59-86

Complete Inlet Plumbing Assembly, R-L

05700-004-59-79

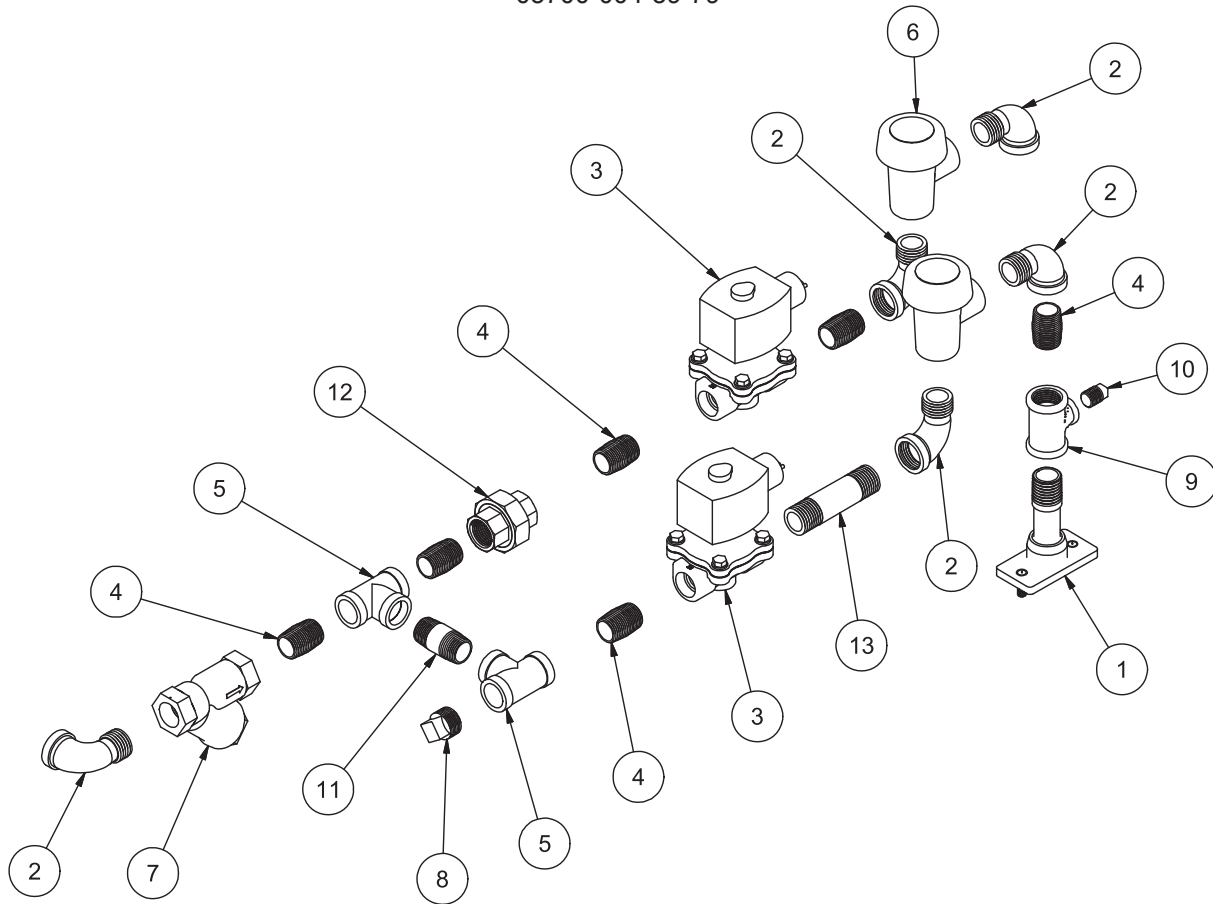

| ITEM | QTY | DESCRIPTION | PART NUMBER |
|------|-----|------------------------------------|---------------------------------|
| 1 | 1 | Manifold, Tank Fill | 05700-004-38-64 |
| 2 | 5 | Elbow, 90-degree 1/2" Street Brass | 04730-206-08-00 |
| 3 | 2 | Solenoid Valve, 1/2" | 04810-003-71-55 |
| 4 | 6 | Nipple, 1/2" Close Brass | 04730-207-15-00 |
| 5 | 2 | Tee, 1/2" Brass | 04730-211-27-00 |
| 6 | 2 | Vacuum Breaker, 1/2" Brass | 04820-003-06-13 |
| 7 | 1 | Y-Strainer, 1/2" | 04730-217-01-10 |
| 8 | 1 | Plug, 1/2" Brass Pipe | 04730-209-03-00 |
| 9 | 1 | Tee, 1/2" x 1/2" x 1/4" | 04730-002-22-56 |
| 10 | 1 | Plug, 1/4" Brass | 04730-209-01-00 |
| 11 | 1 | Nipple, 1/2" x 2" Brass | 04730-207-19-00 |
| 12 | 1 | Union, 1/2" x 1/2" Brass | 04730-003-62-44 |
| 13 | 1 | Nipple, 1/2" x 3" Brass | 04730-004-20-10 |

Complete Rinse Plumbing Assembly, L-R
05700-004-48-52

Complete Rinse Plumbing Assembly, R-L
05700-004-48-45

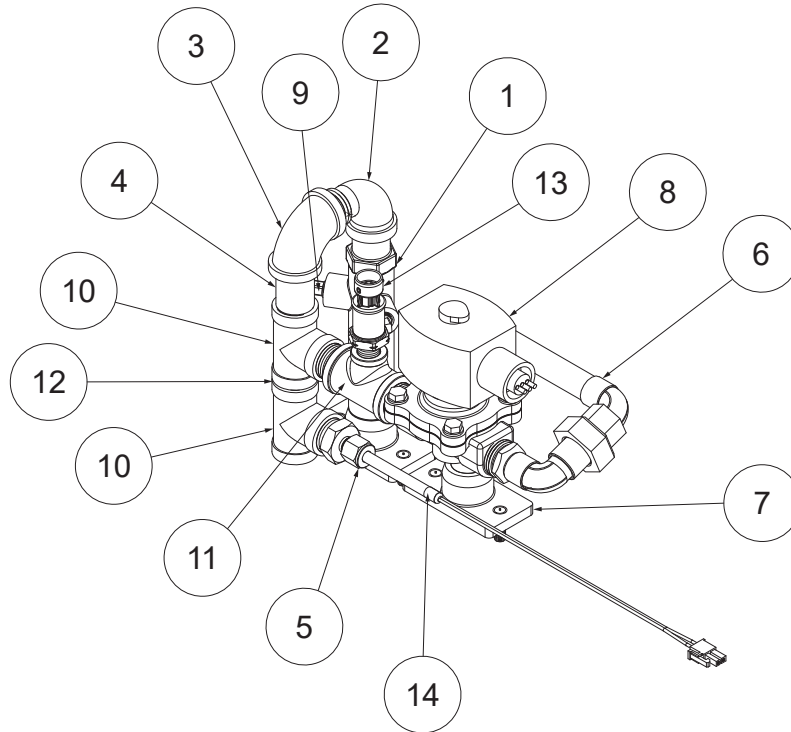

| ITEM | QTY | DESCRIPTION | PART NUMBER |
|------|-----|--|------------------------------------|
| 1 | 1 | Rinse Injector, L-R
Rinse Injector, R-L | 05700-003-76-82
05700-003-76-83 |
| 2 | 1 | Elbow, 90-degree 1/2" Street Brass | 04730-206-08-00 |
| 3 | 1 | Elbow, 1/2" Brass | 04730-011-42-96 |
| 4 | 1 | Nipple, 1/2" x 2" Brass | 04730-207-19-00 |
| 5 | 1 | Fitting, Comp. 1/2" x 1/4" | 05700-004-36-74 |
| 6 | 1 | Piping Manifold, L-R
Piping Manifold, R-L | 05700-004-48-42
05700-004-48-46 |
| 7 | 1 | Manifold, Turbo Rinse, Water In | 05700-004-38-67 |
| 8 | 1 | Solenoid Valve, 1/2" | 04810-003-71-55 |
| 9 | 4 | Plug, 1/8" Brass | 04730-209-07-37 |
| 10 | 2 | Tee, 1/2" Brass | 04730-211-27-00 |
| 11 | 1 | Tee, 1/2" x 1/2" x 1/4" Brass | 04730-002-22-56 |
| 12 | 3 | Nipple, 1/2" Close Brass | 04730-207-15-00 |
| 13 | 1 | Pressure Transducer | 05945-004-17-01 |
| 14 | 1 | Probe, Thermistor 4" with 18" Cable | 06685-004-34-58 |
| 15 | 2 | Plug, 1/4" Brass | 04730-209-01-00 |
| 16 | 2 | Gasket for Items 1 and 7 (Not Shown) | 05330-003-75-91 |

Complete Pre-wash Fill Plumbing Assembly
05700-004-59-80

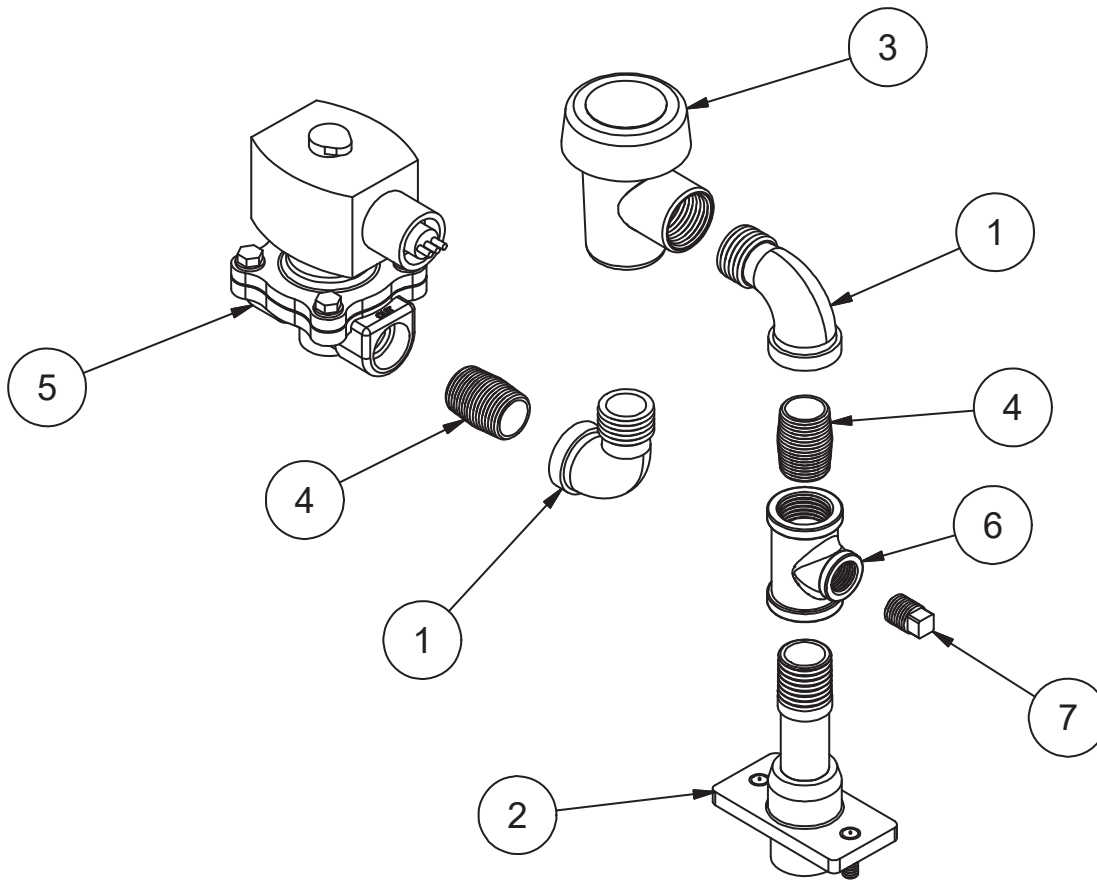

| ITEM | QTY | DESCRIPTION | PART NUMBER |
|------|-----|------------------------------------|-----------------|
| 1 | 2 | Elbow, 90-degree 1/2" Street Brass | 04730-206-08-00 |
| 2 | 1 | Manifold, Tank Fill | 05700-004-38-64 |
| 3 | 1 | Vacuum Breaker, 1/2" Brass | 04820-003-06-13 |
| 4 | 2 | Nipple, 1/2" Close Brass | 04730-207-15-00 |
| 5 | 1 | Solenoid Valve, 1/2" | 04810-003-71-55 |
| 6 | 1 | Tee, 1/2" x 1/2" x 1/4" | 04730-002-22-56 |
| 7 | 1 | Plug, 1/4" Brass | 04730-209-01-00 |

Complete ER Fill Plumbing Assembly, L-R
05700-004-41-53

Complete ER Fill Plumbing Assembly, R-L
05700-004-41-54

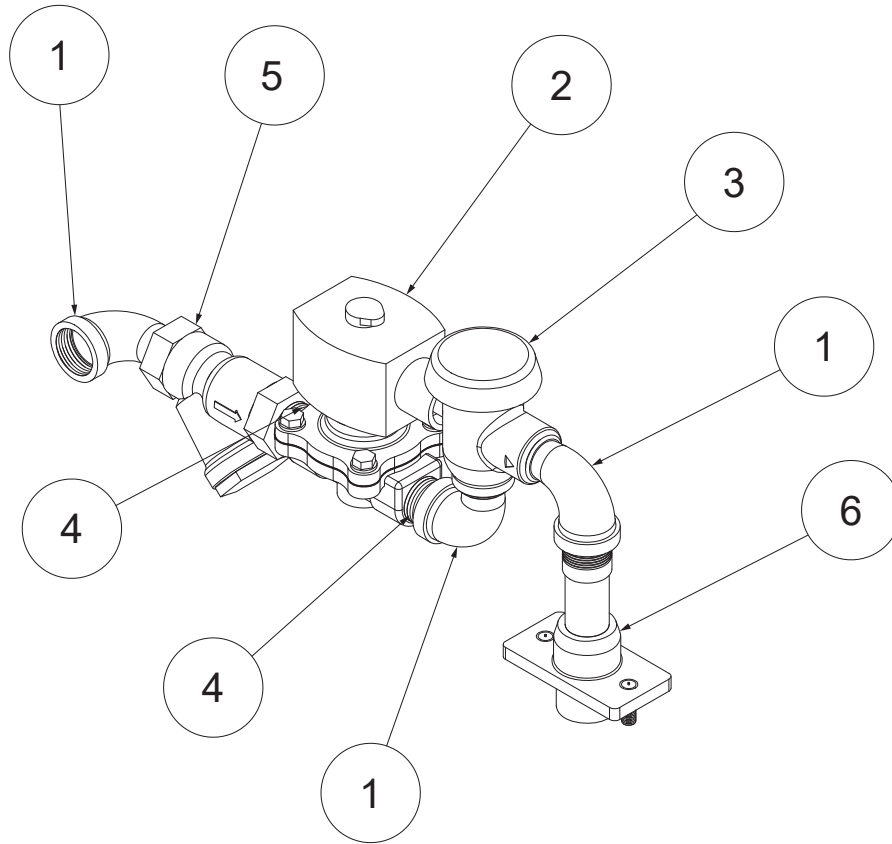

| ITEM | QTY | DESCRIPTION | PART NUMBER |
|------|-----|------------------------------------|---------------------------------|
| 1 | 3 | Elbow, 90-degree 1/2" Street Brass | 04730-206-08-00 |
| 2 | 1 | Solenoid Valve, 1/2" | 04810-003-71-55 |
| 3 | 1 | Vacuum Breaker, 1/2" Brass | 04820-003-06-13 |
| 4 | 2 | Nipple, 1/2" Close Brass | 04730-207-15-00 |
| 5 | 1 | Y-Strainer, 1/2" | 04730-217-01-10 |
| 6 | 1 | Manifold, Tank Fill | 05700-004-38-64 |

Complete ER Inlet Plumbing Assembly, L-R
05700-004-41-62

Complete ER Inlet Plumbing Assembly, R-L
05700-004-41-63

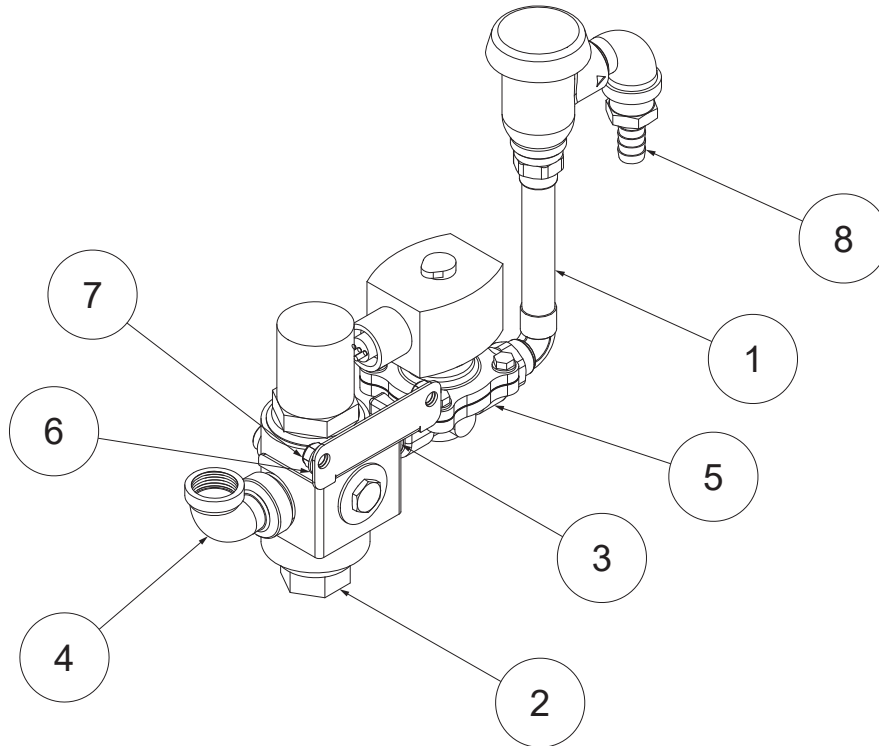

| ITEM | QTY | DESCRIPTION | PART NUMBER |
|------|-----|---------------------------------------|---------------------------------|
| 1 | 1 | Piping Manifold, Vacuum Breaker | 05700-004-74-02 |
| 2 | 1 | Pressure Regulator | 05700-004-94-35 |
| 3 | 1 | Nipple, 1/2" Close Brass | 04730-207-15-00 |
| 4 | 1 | Elbow, 90-degree 1/2" Street Brass | 04730-206-08-00 |
| 5 | 1 | Solenoid Valve, 1/2" | 04810-003-71-55 |
| 6 | 2 | Washer, 1/4-20 | 05311-174-01-00 |
| 7 | 2 | Locknut, 1/4-20 Hex with Nylon Insert | 05310-374-01-00 |
| 8 | 1 | Connector, 1/2" x 1/2" Barbed | 85783405 |

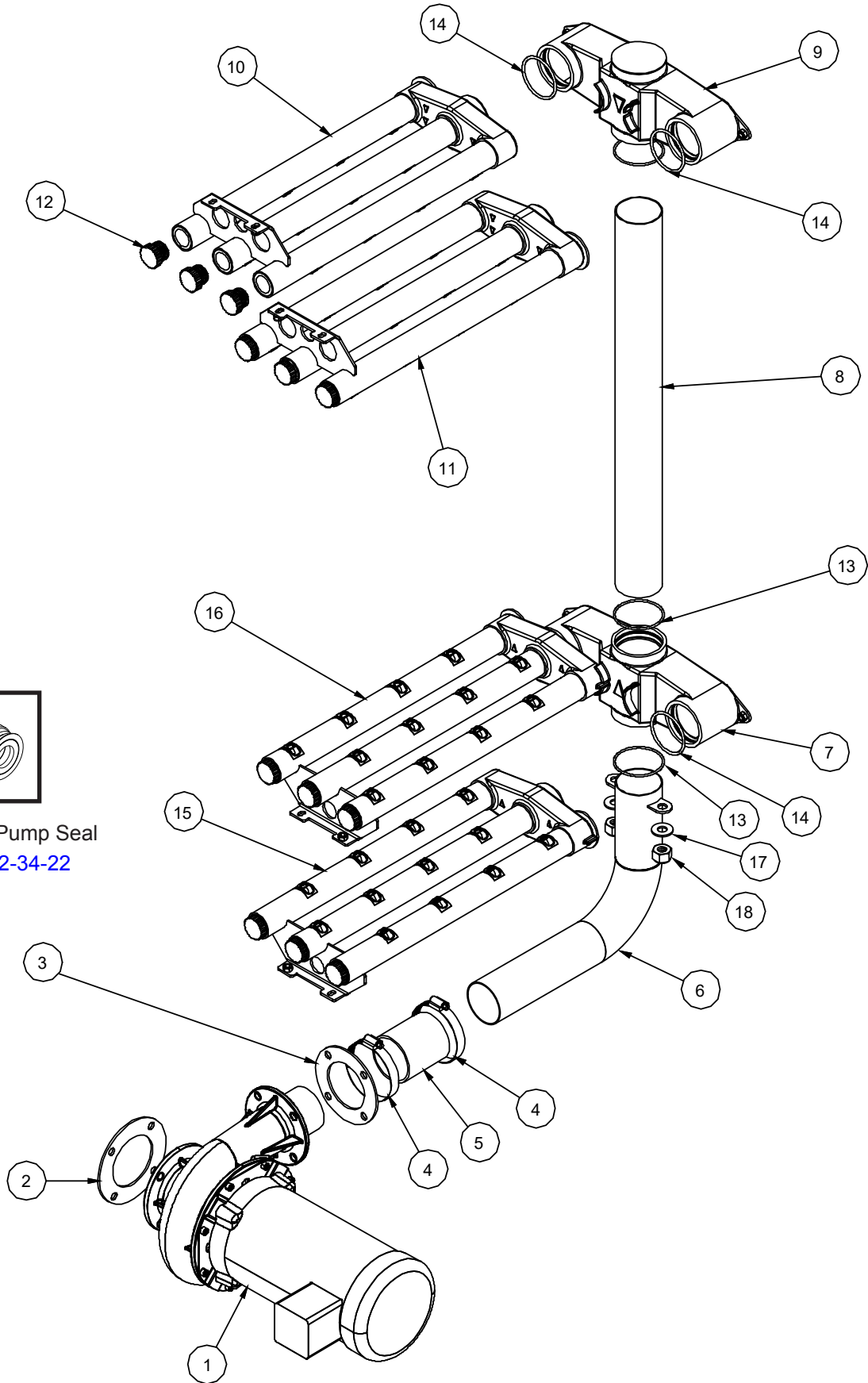

Mechanical Pump Seal
05330-002-34-22

| ITEM | QTY | DESCRIPTION | PART NUMBER |
|------|-----|--|--|
| 1 | 1 | Pump & Motor Assembly | See Table Below |
| 2 | 1 | Gasket, Pump Suction | 05330-003-75-87 |
| 3 | 1 | Gasket, Pump Discharge | 05330-003-75-88 |
| 4 | 2 | Hose Clamp, Range 2 9/16" to 3 1/2" | 04730-003-15-40 |
| 5 | 1 | Hose, Wash Pump Discharge | 05700-003-77-62 |
| 6 | 1 | Lower Wash Manifold, L-R
Lower Wash Manifold, R-L | 05700-004-27-39
05700-005-14-27 |
| 7 | 1 | Casting, Wash Manifold | 09515-003-71-50 |
| 8 | 1 | Tube, Manifold Riser | 05700-003-72-37 |
| 9 | 1 | Upper Wash Manifold | 05700-003-73-66 |
| 10 | 1 | Wash Arm, Top-right
Wash Arm, Top-right, HH L-R | 05700-003-75-79
05700-004-69-50 |
| 11 | 1 | Wash Arm, Top-left
Wash Arm, Top-left, HH R-L | 05700-003-75-80
05700-004-69-51 |
| 12 | 12 | Cap, Threaded | 04730-603-12-00 |
| 13 | 3 | O-ring, Silicone, 0.103 Dia., 2 1/2" x 2 11/16" OD | 05330-003-73-71 |
| 14 | 4 | O-ring, Silicone, 0.139 Dia., 2 1/4" ID x 2 1/2" OD | 05330-003-73-72 |
| 15 | 1 | Wash Arm, Bottom-right | 05700-004-27-43 |
| 16 | 1 | Wash Arm, Bottom-left | 05700-004-27-42 |
| 17 | 2 | Washer, 1/4-20 | 05311-174-01-00 |
| 18 | 2 | Nut, Nylon Lock, 1/4-20 | 05305-374-01-00 |

| PUMP & MOTOR ASSEMBLY | PART NUMBER |
|---|---------------------------------|
| Wash Pump, 3 HP, 208 V, 60 Hz, 3-Phase | 05700-004-84-95 |
| Wash Pump, 3 HP, 230 V, 60 Hz, 3-Phase | 05700-004-84-95 |
| Wash Pump, 3 HP, 460 V, 60 Hz, 3-Phase | 05700-004-84-95 |
| Wash Pump, 3 HP, 600 V, 60 Hz, 3-Phase | 05700-005-05-14 |
| Wash Pump, 3 HP, 208-230 V, 50-60 Hz, 1-Phase | 05700-004-95-11 |

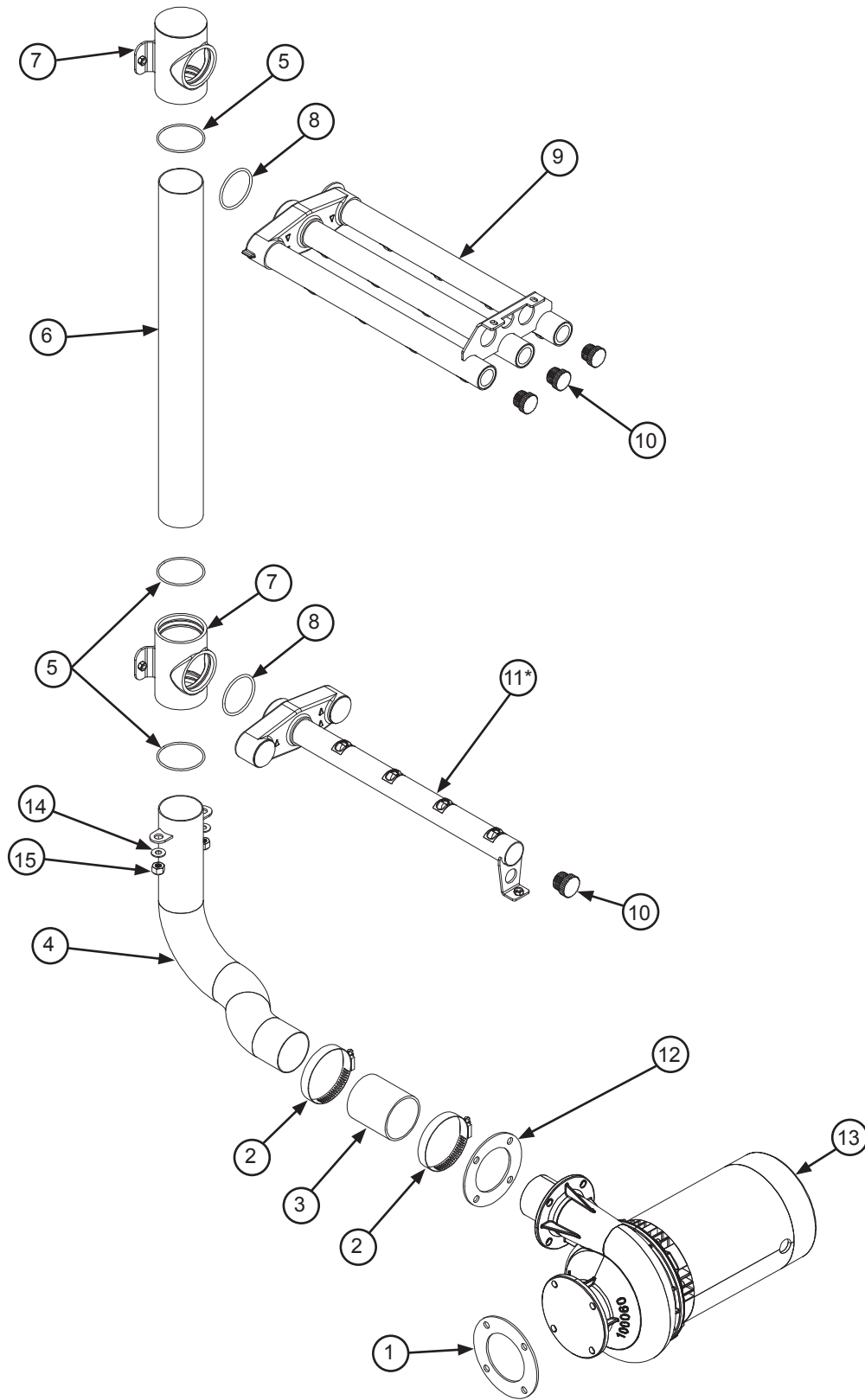

Mechanical Pump Seal
05330-002-34-22

| ITEM | QTY | DESCRIPTION | PART NUMBER |
|------|-----|---|------------------|
| 1 | 1 | Gasket, Pump Suction | 05330-003-75-87 |
| 2 | 2 | Hose Clamp | 04730-003-15-40 |
| 3 | 1 | Hose, Wash Pump Discharge | 05700-003-77-62 |
| 4 | 1 | Manifold, Pre-wash System | 05700-004-31-60 |
| 5 | 3 | O-ring, Silicone, 0.103 Dia., 2 1/2" x 2 11/16" OD | 05330-003-73-71 |
| 6 | 1 | Tube, Manifold Riser | 05700-003-81-53 |
| 7 | 2 | Casting, Pre-wash Manifold | 09515-003-77-22 |
| 8 | 2 | O-ring, Silicone, 0.139 Dia., 2 1/4" ID x 2 1/2" OD | 05330-003-73-72 |
| 9 | 1 | Pre-wash Arm | 05700-003-75-79 |
| 10 | 4 | Cap, Threaded | 04730-603-12-00 |
| 11* | 1 | Pre-wash Arm, Lower | 05700-004-64-87* |
| 12 | 1 | Gasket, Pump Discharge | 05330-003-75-88 |
| 13 | 1 | Pre-wash Motor | See Table Below |
| 14 | 2 | Washer, 1/4-20 | 05311-174-01-00 |
| 15 | 2 | Nut, Nylon Lock, 1/4-20 | 05305-374-01-00 |

| PUMP & MOTOR ASSEMBLY | PART NUMBER |
|---|-----------------|
| Pre-wash Pump, 2HP, 208 V, 60 Hz, 3-Phase | 05700-004-84-96 |
| Pre-wash Pump, 2HP, 230 V, 60 Hz, 3-Phase | 05700-004-84-96 |
| Pre-wash Pump, 2HP, 460 V, 60 Hz, 3-Phase | 05700-004-84-96 |
| Pre-wash Pump, 2HP, 600 V, 60 Hz, 3-Phase | 05700-005-05-15 |
| Pre-wash Pump, 3 HP, 208-230 V, 50-60 Hz, 1-Phase | 05700-004-95-11 |

*Machines before 191378950 use 05700-003-80-96.

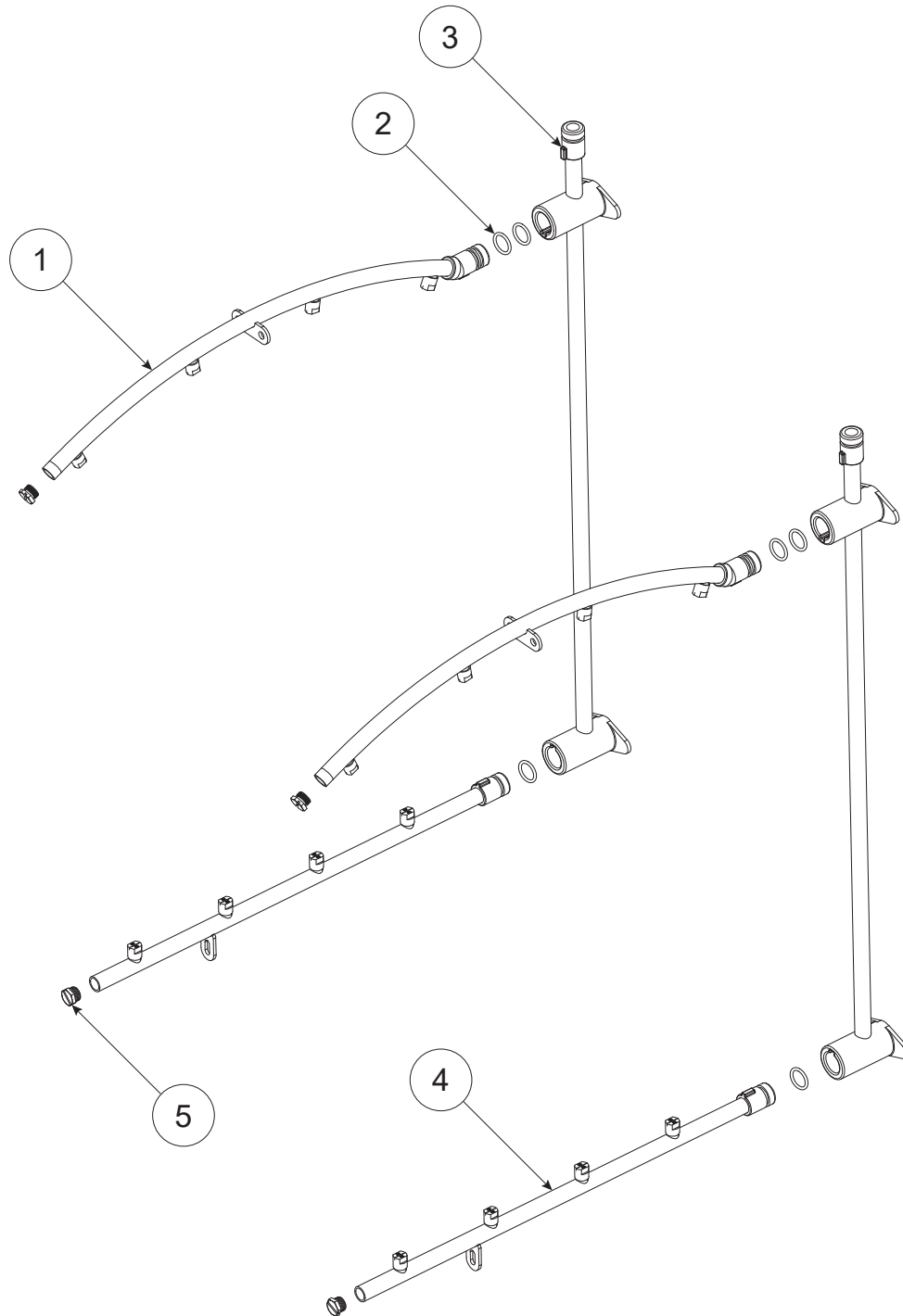

| ITEM | QTY | DESCRIPTION | PART NUMBER |
|------|-----|---|------------------------------------|
| 1 | 2 | Upper Rinse Arm | 05700-003-76-02 |
| 2 | 6 | O-ring, Silicon, 0.103 Dia., 11/16" x 7/8" OD | 05330-003-77-82 |
| 3 | 2 | Rinse Manifold
Rinse Manifold, HH | 05700-003-76-79
05700-004-49-62 |
| 4 | 2 | Lower Rinse Arm | 05700-004-32-95 |
| 5 | 4 | End-cap, Rinse Arm | 05700-004-49-88 |

WATER HAMMER ARRESTOR OPTION

Water Hammer Arrestor
Complete Assembly
05700-002-64-67

Water Hammer Arrestor
Repair Kit
(Plunger & O-ring)
06401-003-06-23

Nipple, 1/2" NPT, Brass
04730-207-15-00

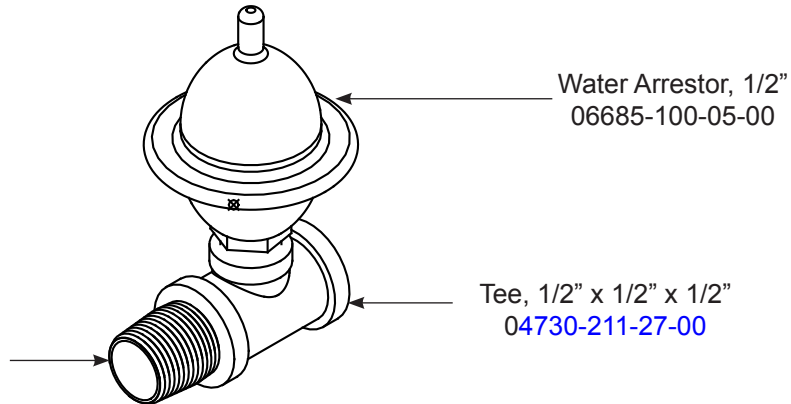

PRESSURE REGULATING VALVE OPTION*

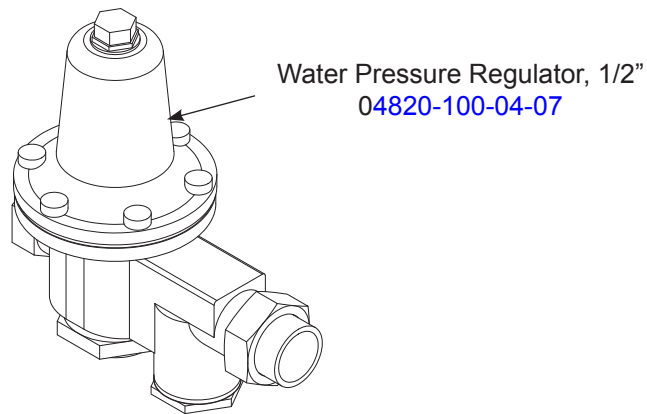

NOTICE *PRV comes standard on ER units only.

WATER TREATMENT OPTION

Scaltrol System
04730-003-05-76

Replacement Cartridge
(inspect at least every 6 months)
RSC-100

NOTICE
Must be installed vertically. Provided bracket is secured to wall. Observe proper inlet/outlet water directions (flow directions are molded into top of head). Line pressure should be released before changing cartridges. Machine should be delimed before installation.

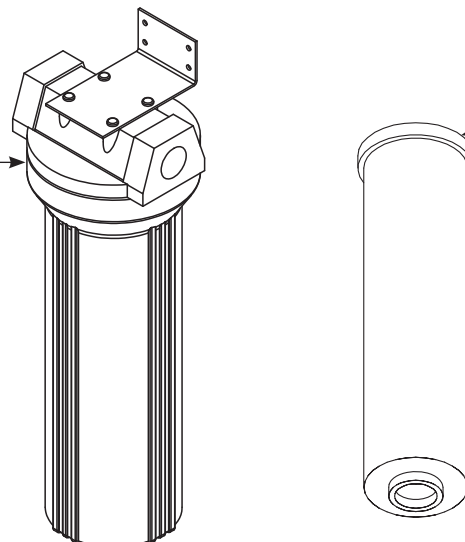

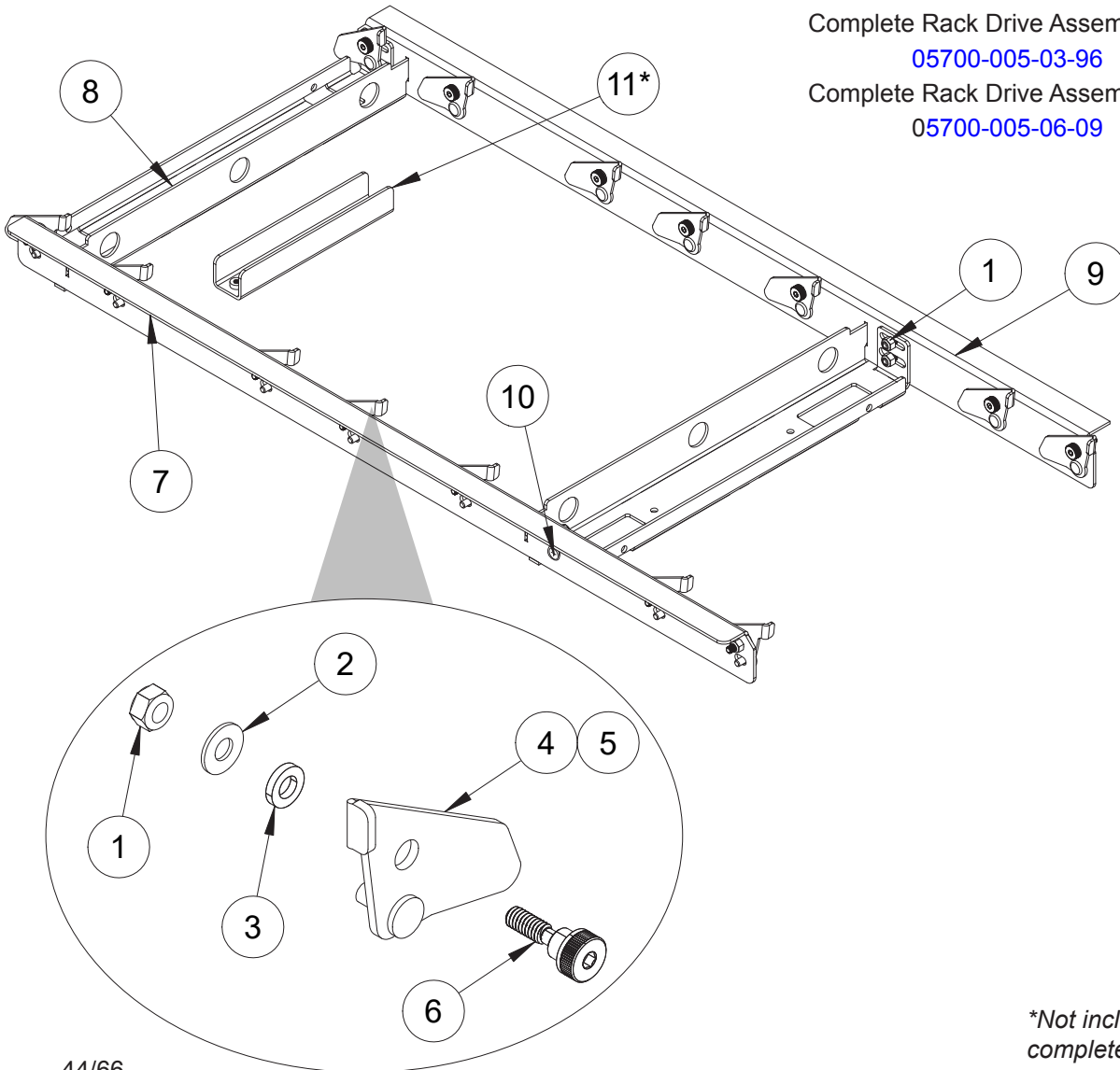

Complete Rack Drive Assembly - 44
[05700-005-03-96](#)
 Complete Rack Drive Assembly - 66
[05700-005-06-09](#)

**Not included in complete assembly.*

44/66

| ITEM | QTY | DESCRIPTION | PART NUMBER |
|------|-------|--|------------------------------------|
| 1 | 18/26 | Locknut, 1/4-20 Hex with Nylon Insert | 05310-374-01-00 |
| 2 | 14/22 | Washer, 1/4-20 | 05311-174-01-00 |
| 3 | 14/22 | Washer, Flat, 0.406 ID x 0.750 OD | 05311-004-29-35 |
| 4 | 7/11 | Rack Catch, Left | 05700-004-29-32 |
| 5 | 7/11 | Rack Catch, Right | 05700-004-29-33 |
| 6 | 14/22 | Bolt, Shoulder, 3/8" x 1/4", 1/4-20 | 05306-004-29-34 |
| 7 | 1 | Rack Drive, Right - 44
Rack Drive, Right - 66 | 05700-005-03-91
05700-005-04-03 |
| 8 | 2 | Rack Drive Frame | 05700-005-03-95 |
| 9 | 1 | Rack Drive, Left - 44
Rack Drive, Left - 66 | 05700-005-03-93
05700-005-04-04 |
| 10 | 4 | Screw, 1/4-20 x 5/8" | 05305-002-20-30 |
| 11* | 1 | Guide, Rack Drive | 05700-004-29-36 |

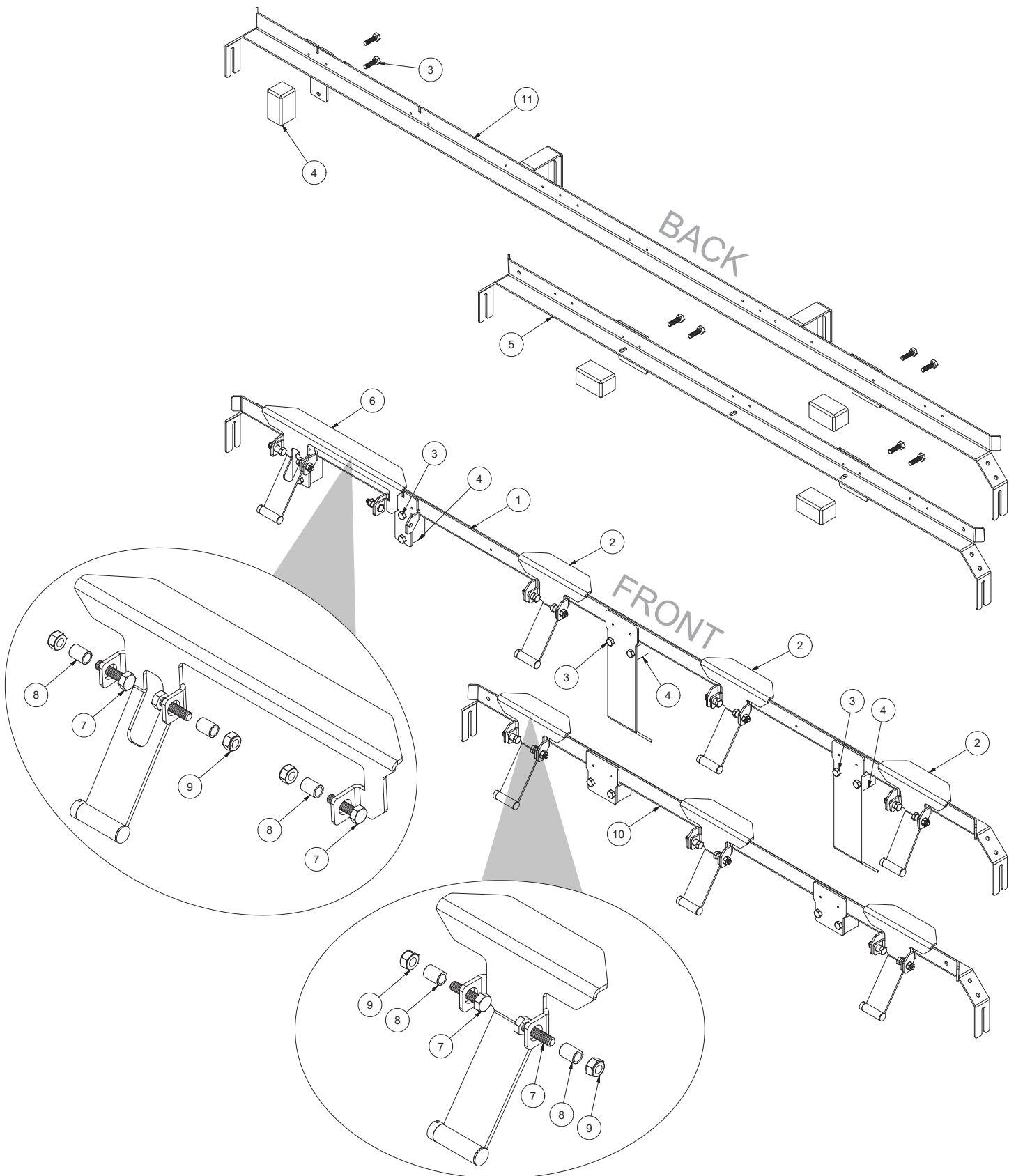

44/66

| ITEM | QTY | DESCRIPTION | PART NUMBER |
|------|------|--|------------------------------------|
| 1 | 1 | Front Rack Rail - 44 | 05700-004-26-87 |
| 2 | 3 | Paddle Switch | 05700-004-26-89 |
| 3 | 8/12 | Screw, 1/4-20 x 7/8" Hex | 05305-274-05-00 |
| 4 | 4/6 | Glide Block | 05700-004-11-75 |
| 5 | 1 | Rear Rack Rail - 44 | 05700-004-22-95 |
| 6 | 0/1 | Paddle Switch, Pre-wash, 66 L-R
Paddle Switch, Pre-wash, 66 R-L | 05700-004-34-03
05700-004-34-06 |
| 7 | 6/9 | Screw, 1/4-20 x 1" Hex | 05305-274-27-00 |
| 8 | 6/9 | Spacer, Rack Guide | 05700-011-71-44 |
| 9 | 6/9 | Locknut, 1/4-20 Hex with Nylon Insert | 05310-374-01-00 |
| 10 | 1 | Front Rack Rail - 66 L-R
Front Rack Rail - 66 R-L | 05700-004-65-05
05700-004-70-66 |
| 11 | 1 | Rear Rack Rail - 66 L-R
Rear Rack Rail - 66 R-L | 05700-005-18-13
05700-005-18-14 |

Front Rack Rail - 44
Complete Assembly
05700-004-26-88

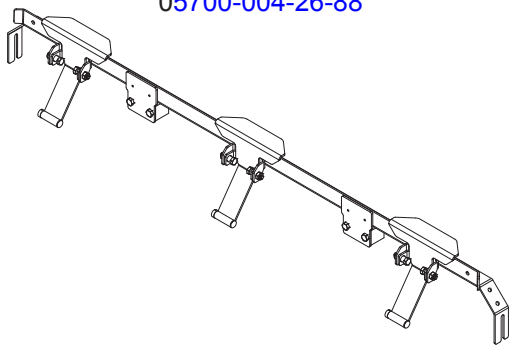

Rear Rack Rail - 44
Complete Assembly
05700-004-26-86

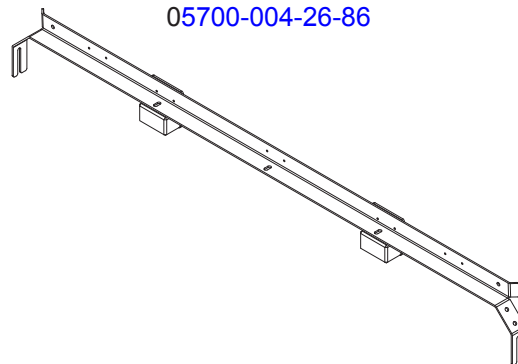

Front Rack Rail - 66
Complete Assembly
Left-to-Right 05700-004-67-04
Right-to-Left 05700-004-70-68

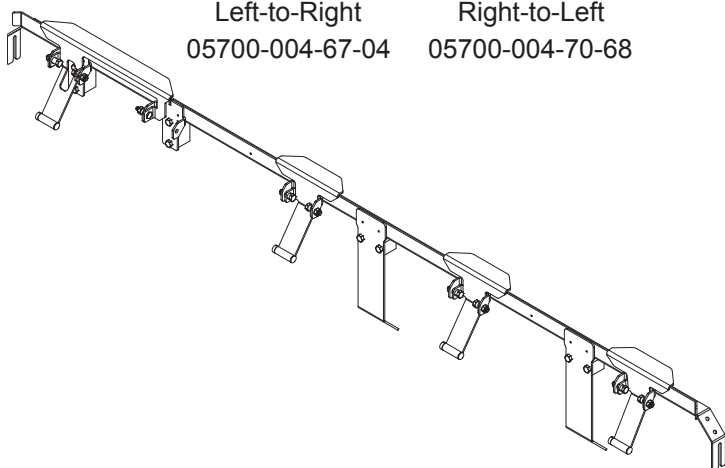

Rear Rack Rail - 66
Complete Assembly
Left-to-Right 05700-005-18-15
Right-to-Left 05700-005-18-16

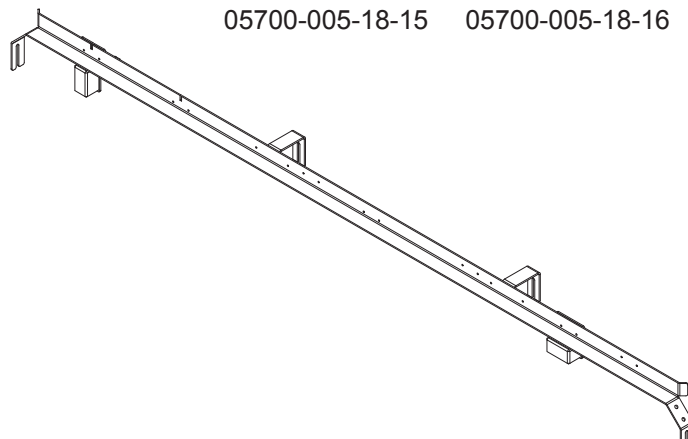

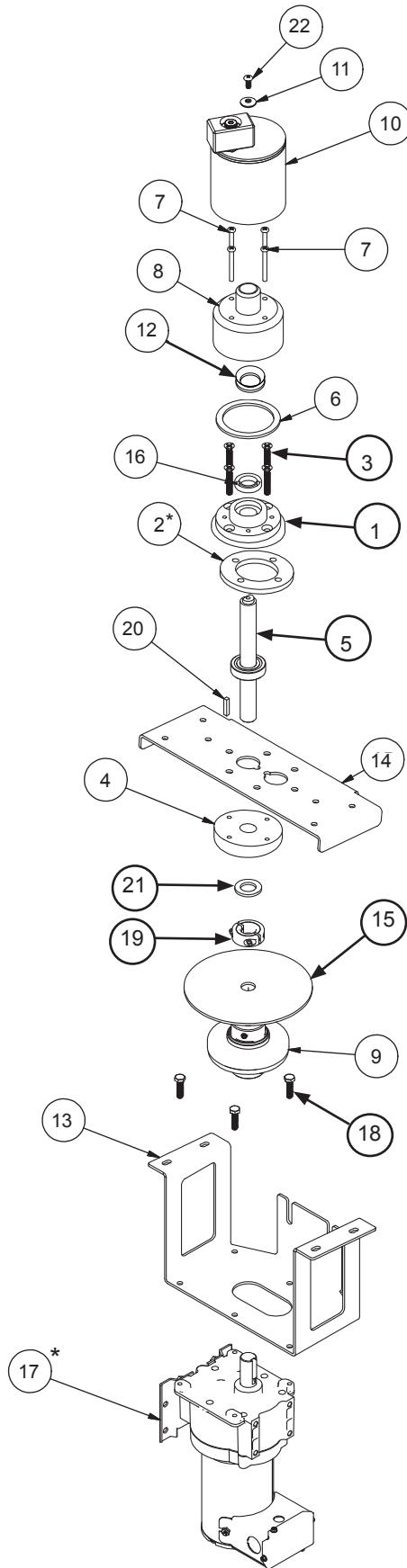

Drive Assembly
05700-004-29-95

| ITEM | QTY | DESCRIPTION | PART NUMBER |
|------|-----|--|-----------------|
| 1 | 1 | Drive Casting, Top | 09515-004-17-06 |
| 2 | 1 | Gasket, Drive Casting | 05330-004-20-31 |
| 3 | 4 | Screw, 1/4-20 x 1 1/2" Hex | 05305-004-55-76 |
| 4 | 1 | Drive Casting, Bottom | 09515-004-17-03 |
| 5 | 1 | Drive Shaft | 05700-004-29-79 |
| 6 | 1 | Gasket, Drain Seat | 05700-002-04-42 |
| 7 | 4 | Screw, 10-32 x 1 3/4" | 05306-003-92-52 |
| 8 | 1 | Drive Shaft Cover | 05700-004-29-46 |
| 9 | 1 | Clutch-Drive, 3/4" x 3/4" | 06105-004-29-41 |
| 10 | 1 | Drive Plate Complete Assembly | 05700-004-29-49 |
| | 1 | Drive Block, Brass (Not Shown) | 05700-004-23-01 |
| | 1 | Washer, 3/8" ID (Not Shown) | 05311-004-48-71 |
| | 1 | Nut, Low-profile, 3/8-16 with Nylon Insert (Not Shown) | 05310-004-48-72 |
| 11 | 1 | Washer, Bonded Sealing 1/4" x 3/4" | 05311-002-77-79 |
| 12 | 1 | Seal, V-ring | 05330-004-52-14 |
| 13 | 1 | Motor Plate | 05700-004-19-38 |
| 14 | 1 | Motor Support Plate | 05700-004-26-97 |
| 15 | 1 | Gasket, Clutch | 05330-004-28-88 |
| 16 | 1 | Seal, Viton Oil Shaft, 3/4" ID | 05330-004-29-06 |
| 17* | 1 | Drive Motor, 3-Phase | 06105-004-29-53 |
| | | Drive Motor, 1-Phase | 06105-004-29-54 |
| 18 | 4 | Bolt, 1/4-28 x 1" Hex Head | 05306-004-30-91 |
| 19 | 1 | Collar, Drive Shaft | 05700-011-89-18 |
| 20 | 1 | Key, 3/16" x 9/10" Long | 05700-011-89-17 |
| 21 | 1 | Bearing, Thrust, 3/4" Shaft x 1 9/16" ID | 03120-004-37-10 |
| 22 | 1 | Screw, 10-32 x 1/2" with Sealing O-ring | 05305-004-26-70 |

*Part not included in complete assembly and must be ordered separately.

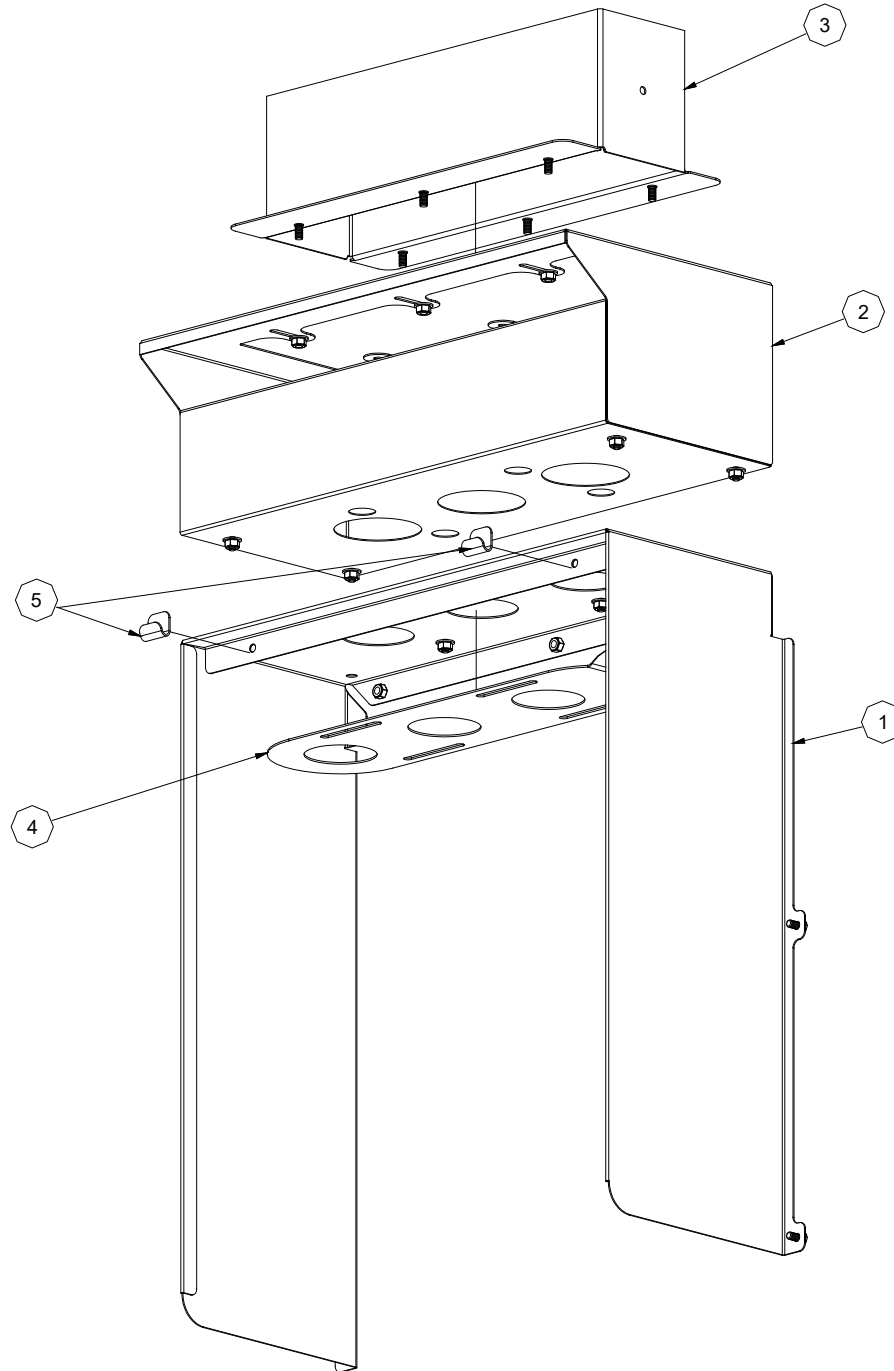

| ITEM | QTY | DESCRIPTION | PART NUMBER |
|------|-----|----------------------------|------------------------------------|
| 1 | 2 | Vent Cowl
Vent Cowl, HH | 05700-004-34-01
05700-004-49-37 |
| 2 | 2 | Vent Scoop | 05700-004-29-68 |
| 3 | 2 | Vent Duct Adapter | 05700-003-75-73 |
| 4 | 2 | Damper, Vent Scoop | 05700-003-74-76 |
| 5 | 4 | Curtain Hook | 05700-003-17-98 |

To attach curtain and rod to Vent Cowl, ensure curtain is oriented as depicted and follow steps below:

- Insert rod into hole at rear of Vent Cowl.
- Insert rod into bracket at front of Vent Cowl.
- Gently lift rod at curtain cut-out over and onto curtain hook ensuring ends of rod stay inserted in holes.

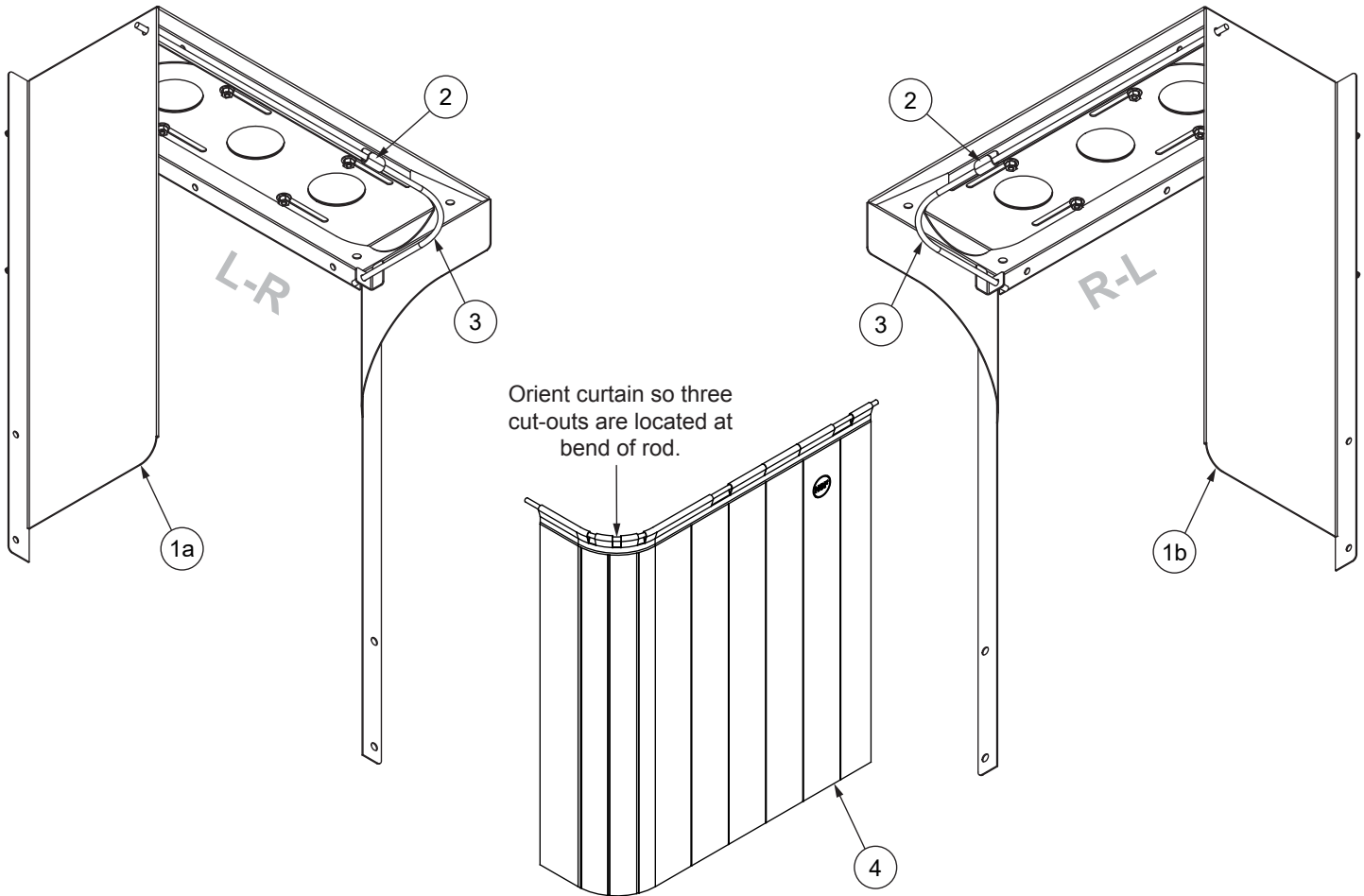

| ITEM | QTY | DESCRIPTION | PART NUMBER |
|------|-----|--|------------------------------------|
| 1a | 1 | Vent Cowl, L-R Side-loader
Vent Cowl, L-R Side-loader, HH | 05700-004-38-27
05700-004-69-21 |
| 1b | 1 | Vent Cowl, R-L Side-loader
Vent Cowl, R-L Side-loader, HH | 05700-004-38-28
05700-004-69-17 |
| 2 | 1 | Curtain Hook | 05700-003-17-98 |
| 3 | 1 | Curtain Rod | 05700-003-84-57 |
| 4 | 1 | Curtain, Side-loader | See Curtains section. |

Pre-Wash Motor (66 Only)

| Volts | Phase | Freq | Motor Overload |
|-------|-------|-------|-----------------|
| 208 | 3 | 60 Hz | 05945-004-25-88 |
| 230 | 3 | 60 Hz | 05945-004-25-88 |
| 460 | 3 | 60 Hz | 05945-004-25-87 |

Wash Motor

| Volts | Phase | Freq | Motor Overload |
|-------|-------|-------|-----------------|
| 208 | 3 | 60 Hz | 05945-004-25-88 |
| 230 | 3 | 60 Hz | 05945-004-25-88 |
| 460 | 3 | 60 Hz | 05945-004-25-87 |

Drive Motor

| Volts | Phase | Freq | Motor Overload |
|-------|-------|-------|---------------------------------|
| 208 | 3 | 60 Hz | 05945-004-25-80 |
| 230 | 3 | 60 Hz | 05945-004-25-80 |
| 460 | 3 | 60 Hz | 05945-004-25-85 |

NOTICE Overloads are for 3-phase only.

This illustration depicts a
 23" Left-to-Right
 Unhooded Side-loader.
 Differences in parts for
 23" Right-to-Left and both
 directions of 30" Side-loaders
 are reflected in parts list.

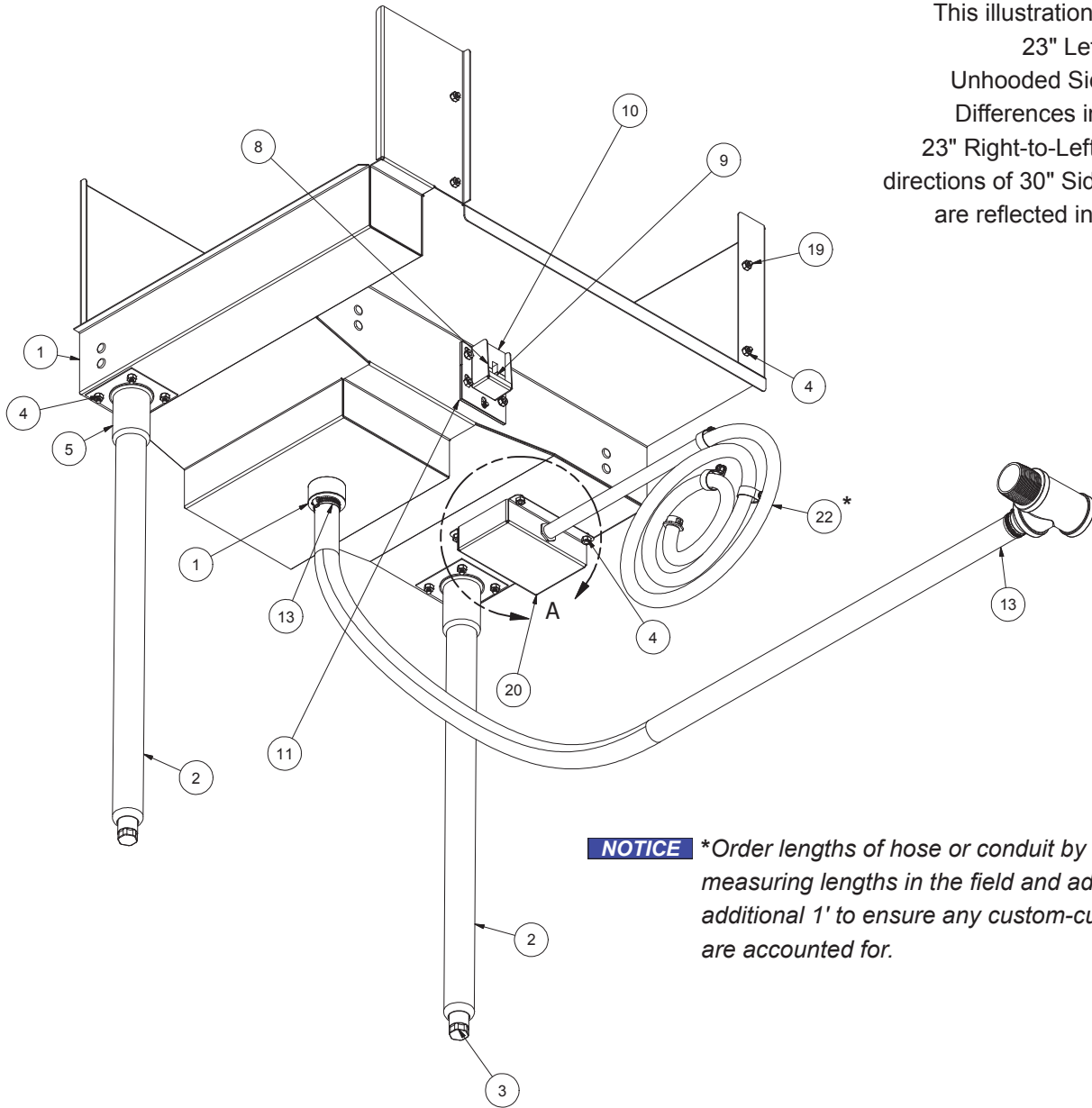

NOTICE *Order lengths of hose or conduit by measuring lengths in the field and adding an additional 1' to ensure any custom-cut lengths are accounted for.

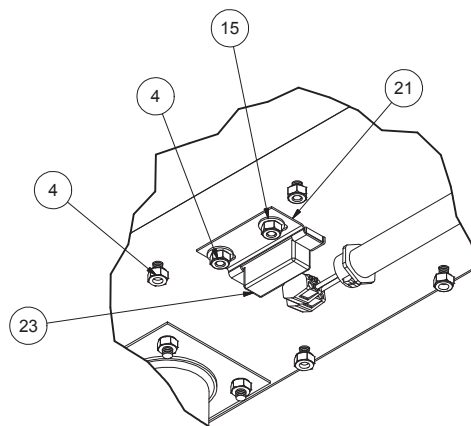

DETAIL A

This illustration depicts a 23" Left-to-Right Unhooded Side-loader. Differences in parts for the 23" Right-to-Left and both directions of the 30" Side-loaders are reflected in the parts list.

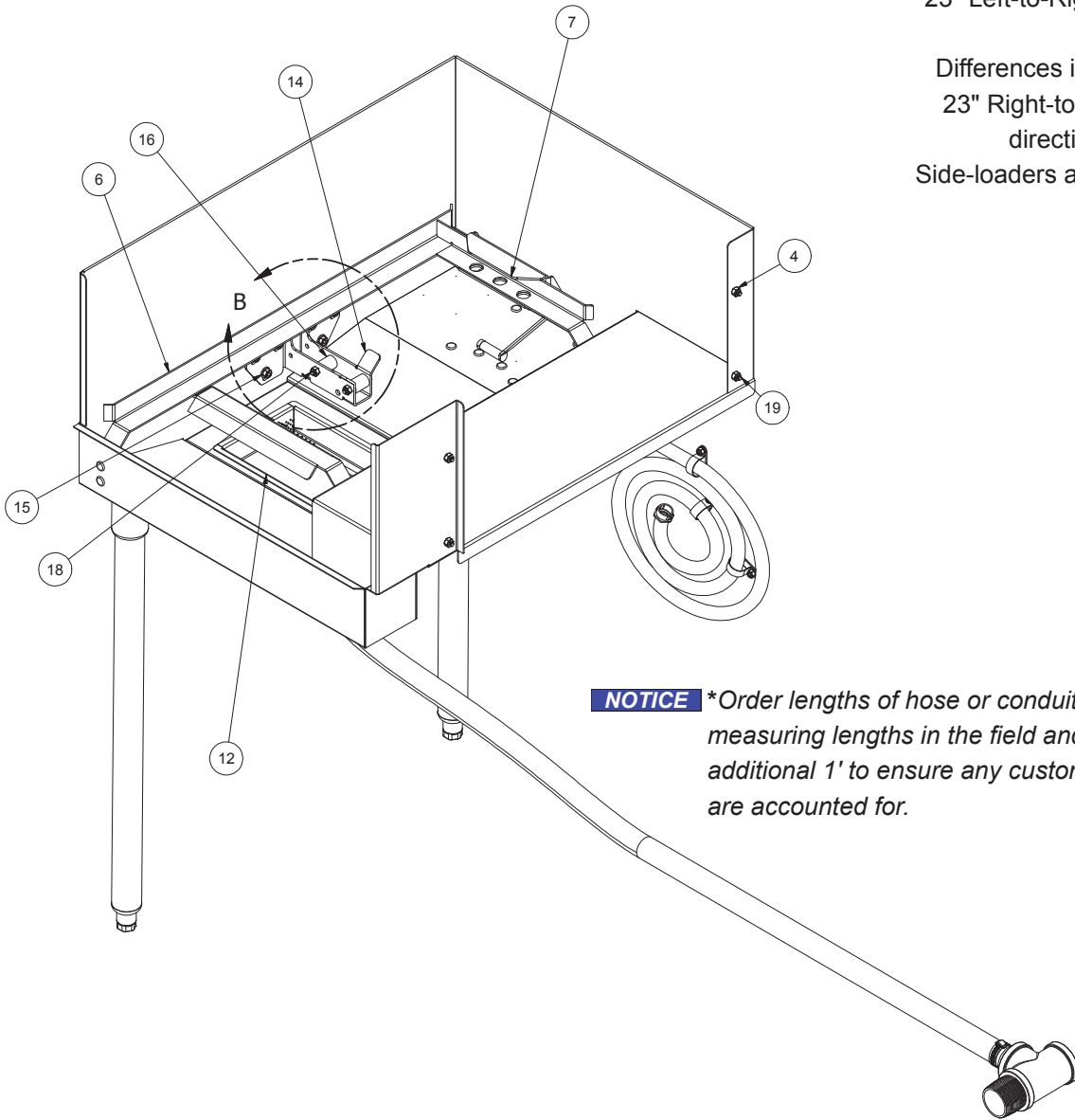

NOTICE *Order lengths of hose or conduit by measuring lengths in the field and adding an additional 1' to ensure any custom-cut lengths are accounted for.

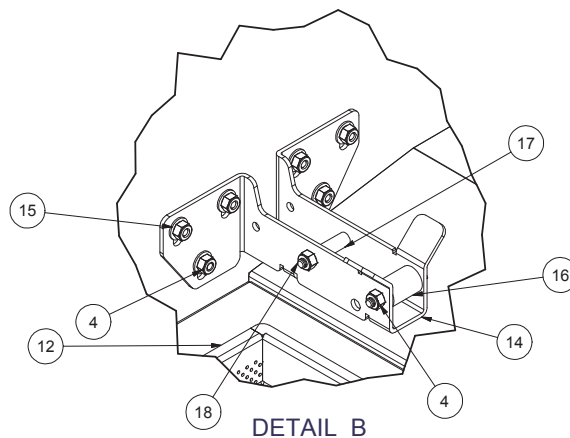

| ITEM | QTY | DESCRIPTION | PART NUMBER |
|------|-----|--|--|
| 1 | 1 | Tub Weldment, 23" Side-loader L-R
Tub Weldment, 23" Side-loader R-L
Tub Weldment, 30" Side-loader L-R
Tub Weldment, 30" Side-loader R-L | 05700-004-37-44
05700-004-38-03
05700-003-88-46
05700-003-88-39 |
| 2 | 2 | Support Leg | 05700-021-87-59 |
| 3 | 2 | Adjustable Foot | 05340-108-01-03 |
| 4 | 39 | Locknut, 1/4-20 Hex with Nylon Insert | 05310-374-01-00 |
| 5 | 2 | Leg Socket | 05700-002-56-14 |
| 6 | 1 | Track, Side-loader L-R | 05700-003-90-00 |
| | | Track, Side-loader R-L | 05700-003-89-95 |
| 7 | 1 | Actuator Switch Assembly | 05700-004-53-51 |
| 8 | 1 | Gutter, Pawl Bar | 05700-021-66-86 |
| 9 | 1 | Guide Block Bottom-slotted | 05700-011-69-50 |
| 10 | 1 | Guide Block Top-slotted | 05700-011-69-49 |
| 11 | 1 | Gasket, Drive Gutter | 05330-011-68-55 |
| 12 | 1 | Strainer | 05700-021-85-10 |
| 13 | 1 | Drain Assembly, Side-loader | 05700-004-38-17 |
| 14 | 1 | Bracket, Loader Pawl Bar Support | 05700-003-87-39 |
| 15 | 16 | Washer, 1/4" | 05311-174-01-00 |
| 16 | 2 | Roller | 05700-011-68-16 |
| 17 | 2 | Roller Shaft | 05700-011-68-14 |
| 18 | 2 | Screw, 1/4-20 x 1 3/4" Hex | 05305-274-10-00 |
| 19 | 4 | Bolt, 1/4-20 x 1/2" | 05305-274-02-00 |
| 20 | 1 | Cover, Side-loader Switch | 05700-003-87-41 |
| 21 | 1 | Bracket, Limit Switch | 05700-021-71-18 |
| 22 | 1 | Conduit and Wiring, Side-loader | 05700-004-38-53 |
| 23 | 1 | Magnetic Reed Switch | 05930-111-68-44 |

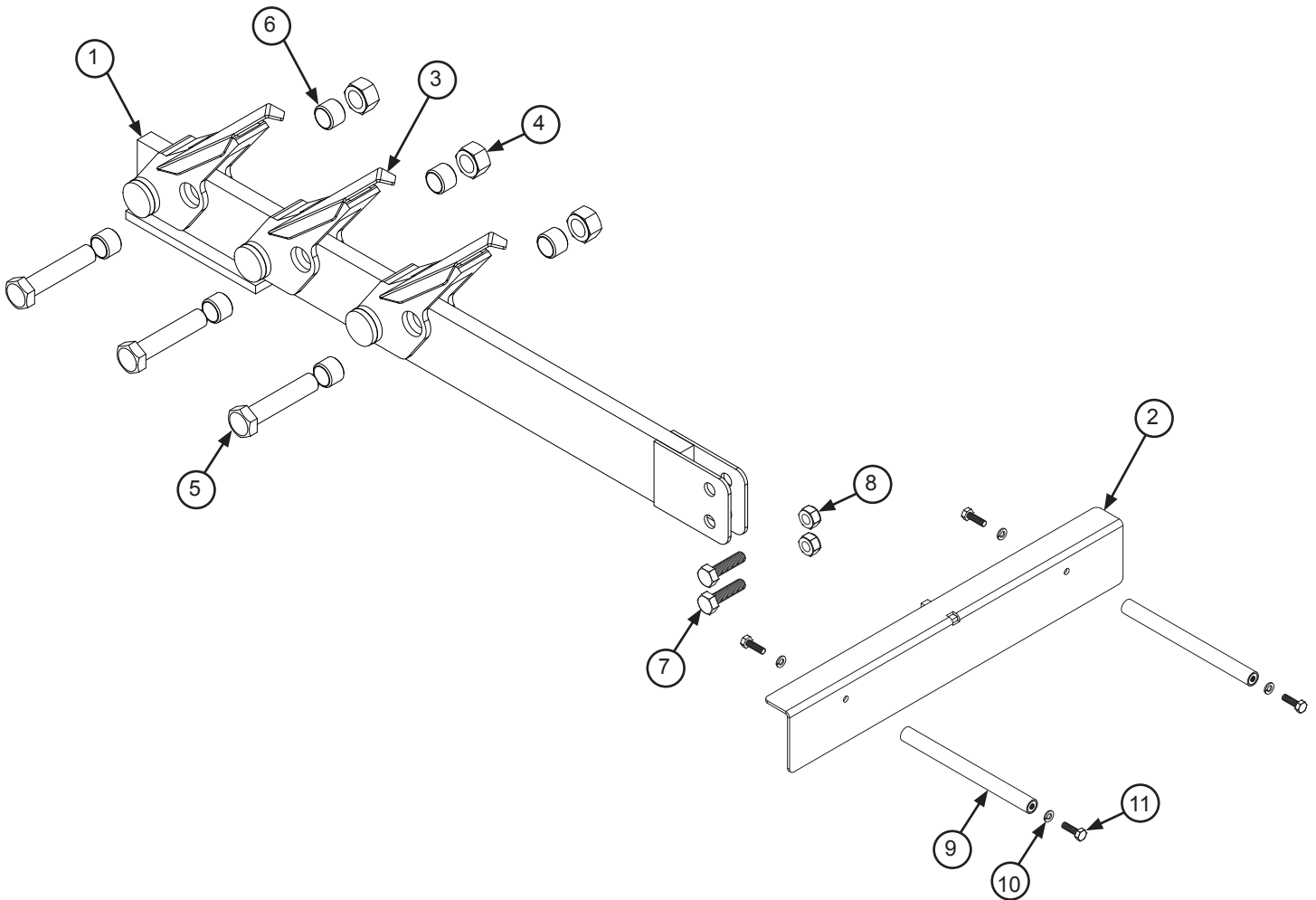

| ITEM | QTY | DESCRIPTION | PART NUMBER |
|------|-----|---------------------------------------|---------------------------------|
| 1 | 1 | Pawl Bar, Side-loader | 05700-021-86-88 |
| 2 | 1 | Drive Linkage, Side-loader | 05700-004-37-81 |
| 3 | 3 | Pawl Dog with Wing | 05700-021-86-79 |
| 4 | 3 | Locknut, 3/8-16 with Nylon Insert | 05310-011-72-55 |
| 5 | 3 | Bolt, 3/8-16 x 1 3/4" Hex | 05306-011-36-94 |
| 6 | 6 | Spacer, Pawl Bar Dog | 05700-011-71-45 |
| 7 | 2 | Screw, 1/4-20 x 1" Hex | 05305-274-27-00 |
| 8 | 2 | Locknut, 1/4-20 Hex with Nylon Insert | 05310-374-01-00 |
| 9 | 2 | Drive Link | 05700-004-46-82 |
| 10 | 4 | Lockwasher, Spring | 05311-274-01-00 |
| 11 | 4 | Screw, 1/4-20 x 7/8" | 05305-274-05-00 |

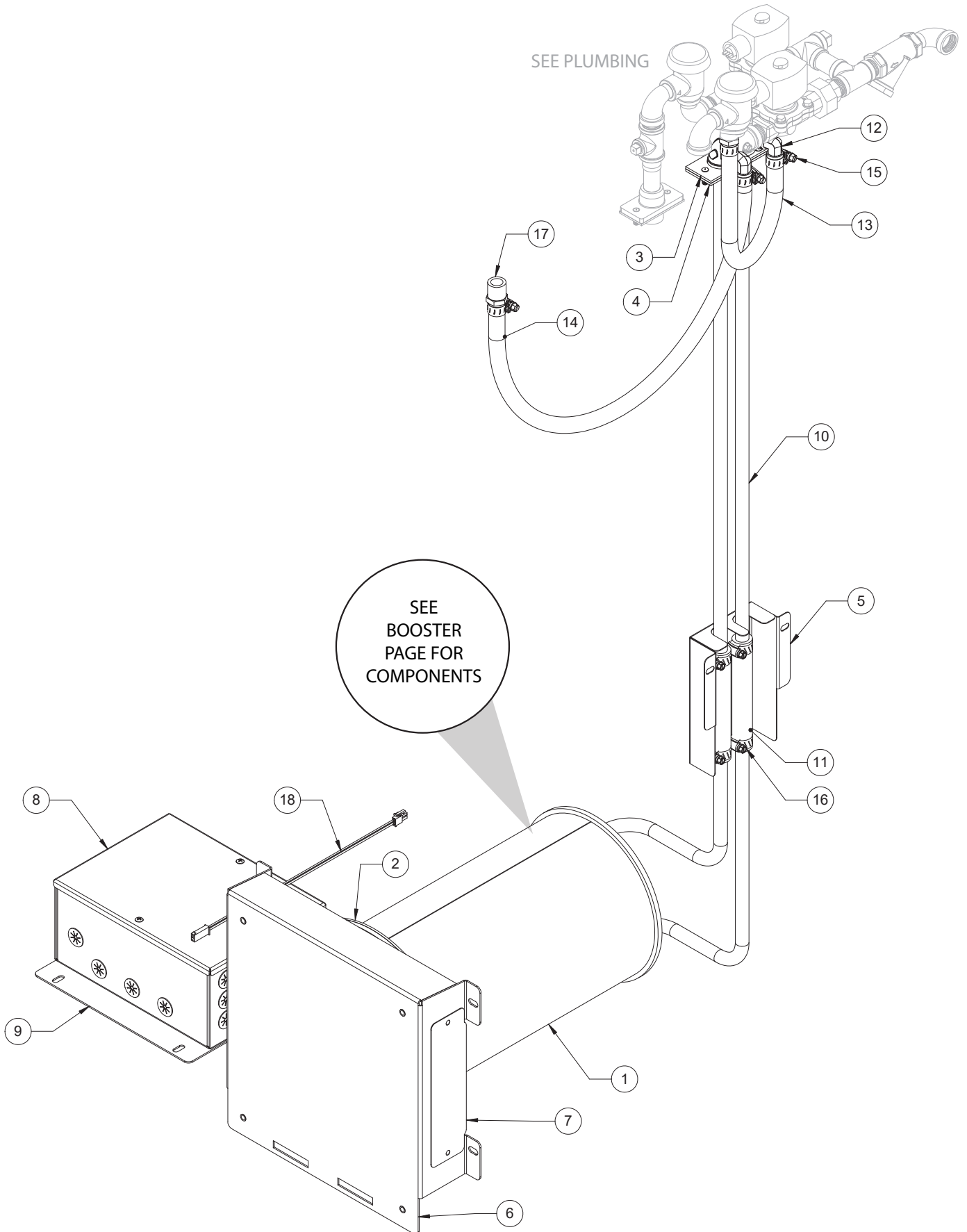

| ITEM | QTY | DESCRIPTION | PART NUMBER |
|------|-----|--|--------------------------------------|
| 1* | 1 | Booster, L-R*
Booster, R-L* | 05700-005-06-84*
05700-005-08-36* |
| 2 | 1 | Gasket, Booster | 05330-005-08-61 |
| 3 | 1 | Manifold, Booster Tubes | 05700-005-14-12 |
| 4 | 1 | Gasket, Booster Manifold | 05330-005-12-85 |
| 5 | 1 | Cover, Rinse Tube | 05700-005-12-81 |
| 6 | 1 | Bracket, Booster Cover | 05700-005-14-24 |
| 7 | 1 | Cover, Booster Wires | 05700-005-12-93 |
| 8 | 1 | Box, Booster Contactors | 05700-005-13-82 |
| 9 | 1 | Plate, Contactor Mounting | 05700-005-12-96 |
| 10 | 2 | Booster, Inlet/Outlet Weld | 05700-005-16-37 |
| 11 | 2 | Hose, 5/8" ID | 05700-004-53-99 |
| 12 | 2 | Elbow, 1/2 x 1/2, Barb Brass | 53525K58 |
| 13 | 1 | Hose, Booster Inlet | 05700-005-16-42 |
| 14 | 1 | Hose, Booster Outlet | 05700-005-16-43 |
| 15 | 4 | Clamp, Hose, 3/8 to 7/8 | 5415K11 |
| 16 | 4 | Clamp, Mini-range, 9/16 to 1 1/16 | 04730-719-06-00 |
| 17 | 2 | Connector, 1/2 x 1/2 | 85783405 |
| 18 | 1 | Cable, Temperature Probe, Booster Tank | 05700-004-33-58 |

*Booster not available on NB models.

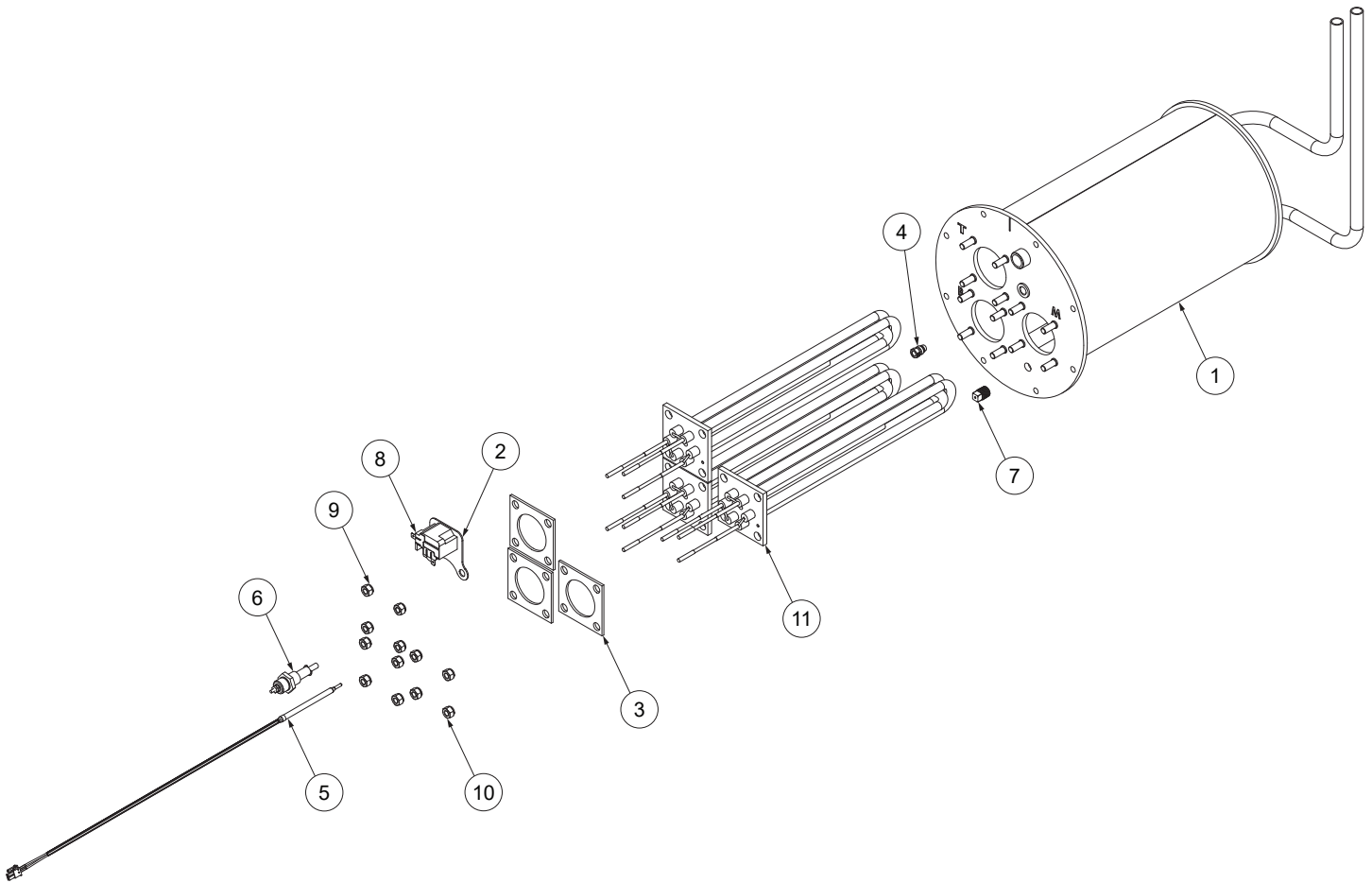

| ITEM | QTY | DESCRIPTION | PART NUMBER |
|------|-----|---|---|
| 1 | 1 | Booster, Weldment, L-R
Booster, Weldment, R-L | 05700-005-10-71
05700-005-10-72 |
| 2 | 1 | Bracket, Thermostat | 05700-004-66-08 |
| 3 | 3 | Gasket, Heater | 05330-011-47-79 |
| 4 | 1 | Fitting, 1/4 Brass Nut/Sleeve | 05310-924-02-05 |
| 5 | 1 | Probe, Fast-acting, Thermistor | 06685-004-75-99 |
| 6 | 1 | Probe, High Water | 06680-200-02-68 |
| 7 | 1 | Plug, Brass | 04730-209-01-00 |
| 8 | 1 | Thermostat, High Limit | 05930-004-33-12 |
| 9 | 12 | Lockwasher, Split 5/16 | 05311-275-01-00 |
| 10 | 12 | Nut, 5/16-18, Hex | 05310-275-01-00 |
| 11 | 3 | Heater, 8 kW, 208 V, 3 PH
Heater, 8 kW, 240 V, 3 PH
Heater, 8 kW, 480 V, 3 PH
Heater, 8 kW, 208 V, 1 PH
Heater, 8 kW, 240 V, 1 PH | 04540-005-12-15
04540-005-12-16
04540-005-12-17
04540-005-12-92
04540-005-12-91 |

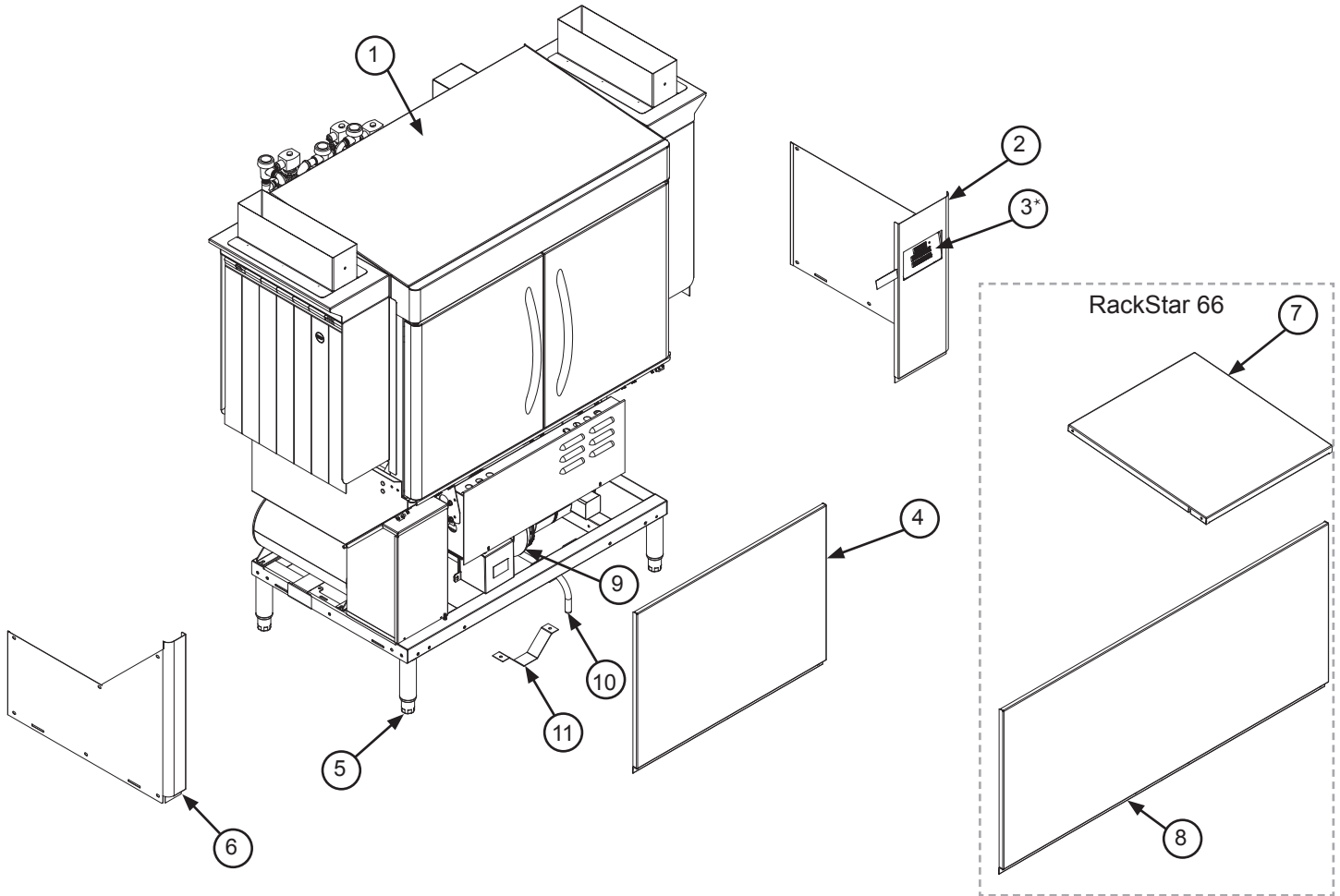

| ITEM | QTY | DESCRIPTION | PART NUMBER |
|------|-----|--------------------------------|---------------------------------|
| 1 | 1 | Hood Dress Panel | 05700-004-45-83 |
| 2 | 1 | Left Dress Panel, L-R | 05700-004-30-60 |
| | | Right Dress Panel, R-L | 05700-004-31-93 |
| 3 | 1 | Display | See Display Assembly page. |
| 4 | 1 | Front Dress Panel, RackStar 44 | 05700-004-30-44 |
| 5 | 1 | Adjustable Foot | 05340-011-71-74 |
| 6 | 1 | Right Dress Panel, L-R | 05700-005-18-20 |
| | | Left Dress Panel, R-L | 05700-005-18-19 |
| 7 | 1 | Pre-wash Hood Dress Panel | 05700-004-30-08 |
| 8 | 1 | Front Dress Panel, RackStar 66 | 05700-004-34-48 |
| 9 | 1 | Drain Valve | 04820-111-71-46 |
| 10 | 1 | Drain Handle Complete Assembly | 05700-004-31-89 |
| | 1 | Drain Handle Only | 05700-004-31-90 |
| 11 | 1 | Support Bracket, Drain Hose | 05700-004-56-71 |
| - | - | Screw, Dress Panel (Not Shown) | 05306-004-42-04 |

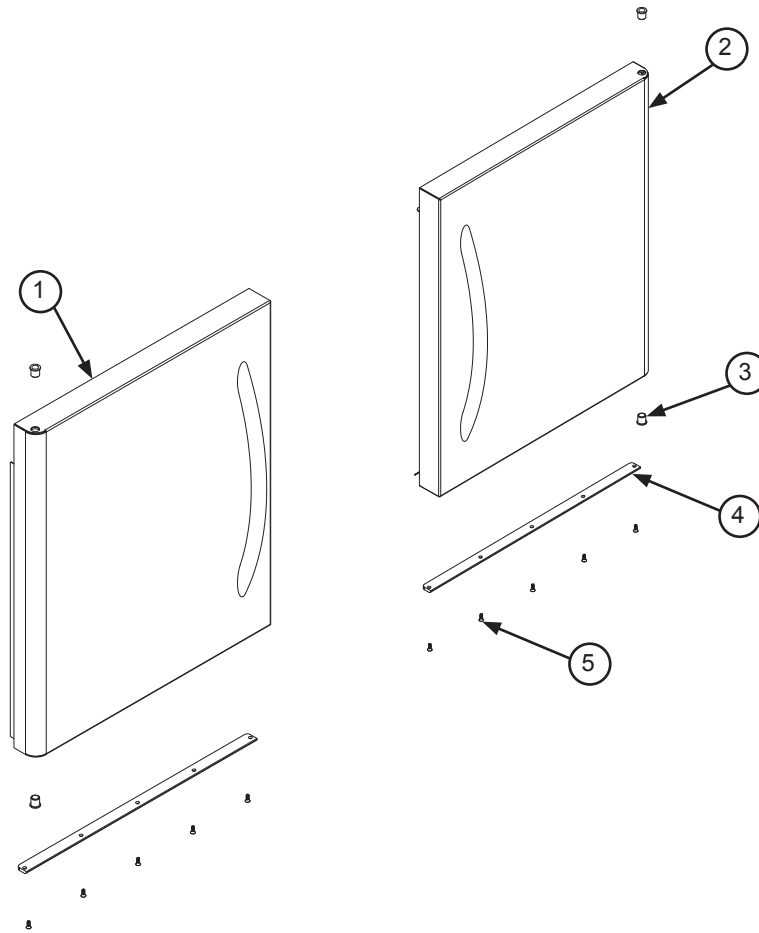

| ITEM | QTY | DESCRIPTION | PART NUMBER |
|------|-----|---|--|
| 1 | 1 | Left Door Assembly
Left Door Assembly, HH | 05700-004-17-45
05700-004-49-44 |
| 2 | 1 | Right Door Assembly
Right Door Assembly, HH | 05700-004-17-44
05700-004-49-46 |
| 3 | 4 | Bearing, Flanged Sleeve | 03120-004-39-92 |
| 4 | 2 | Door Seal | 09330-004-17-41 |
| 5 | 10 | Screw, 10-32 x 1/2" | 05305-011-44-51 |
| 6 | 1 | Door Assembly, Pre-wash, L-R
Door Assembly, Pre-wash, R-L
Door Assembly, Pre-wash, L-R, HH
Door Assembly, Pre-wash, R-L, HH
(Not Shown) | 05700-004-32-76
05700-004-44-35
05700-004-49-70
05700-004-50-25 |

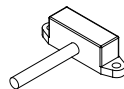

Door Switch
[05930-002-36-80](#)

ENERGY RECOVERY SYSTEM

Complete Energy Recovery System Assembly
 L-R - 05700-004-39-68
 R-L - 05700-004-40-13
 L-R HH - 05700-004-68-92
 R-L HH - 05700-004-69-04

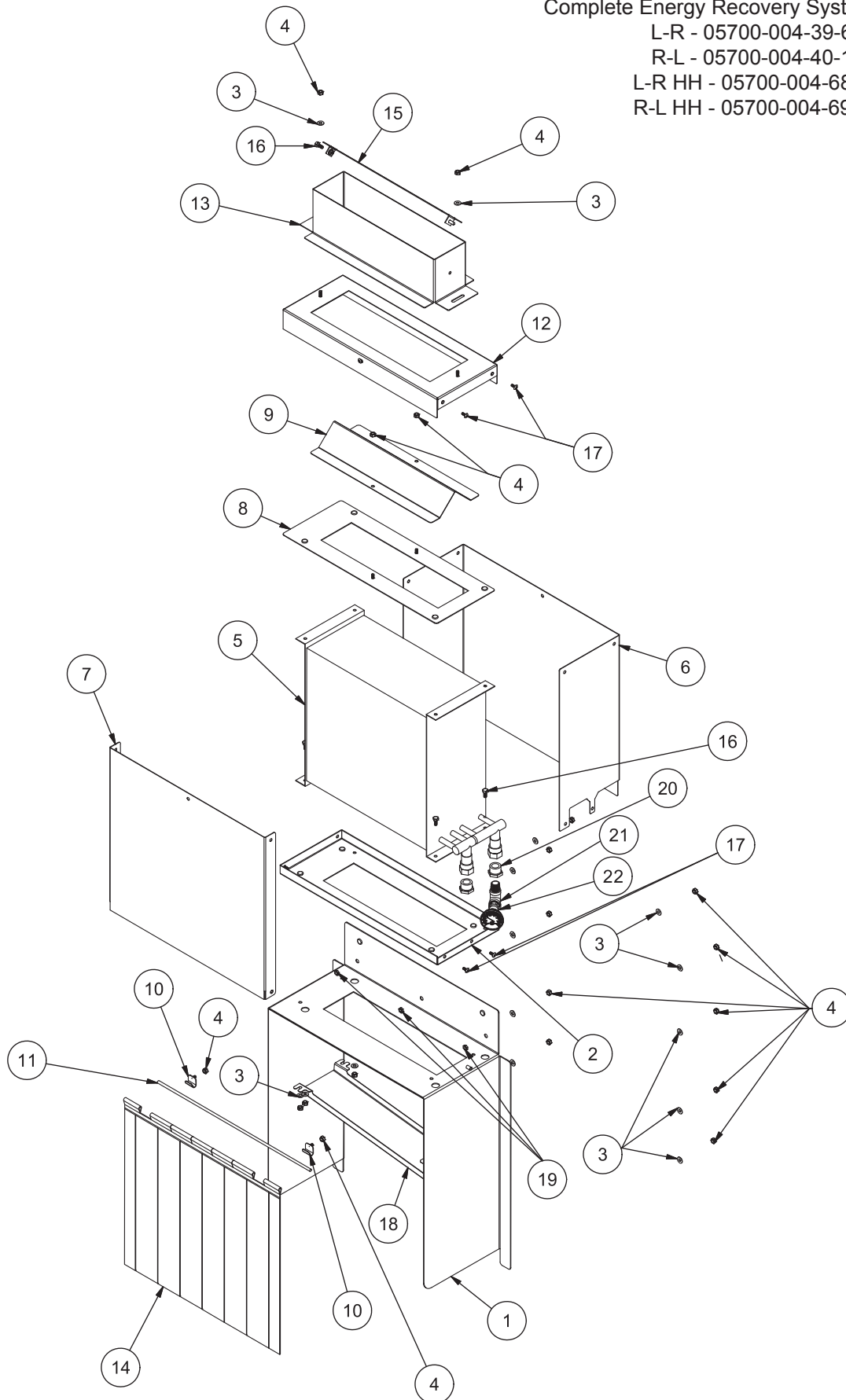

| ITEM | QTY | DESCRIPTION | PART NUMBER |
|------|-----|---|------------------------------------|
| 1 | 1 | Vent Cowl, L-R
Vent Cowl, L-R HH | 05700-004-36-36
05700-004-68-91 |
| | 1 | Vent Cowl, R-L
Vent Cowl, R-L HH | 05700-004-40-16
05700-004-69-03 |
| 2 | 1 | Mounting Plate | 05700-004-36-32 |
| 3 | 20 | Washer, 1/4-20 | 05311-174-01-00 |
| 4 | 24 | Locknut, 1/4-20 Hex with Nylon Insert | 05310-374-01-00 |
| 5 | 1 | Coil, Heat Exchanger | 04420-004-40-73 |
| 6 | 1 | Side Cover, Left | 05700-004-41-17 |
| 7 | 1 | Side Cover, Right | 05700-004-41-18 |
| 8 | 1 | Top Coil Support | 05700-004-40-40 |
| 9 | 1 | Air Baffle | 05700-004-36-66 |
| 10 | 2 | Curtain Hook | 05700-003-17-98 |
| 11 | 1 | Curtain Rod | 05700-003-77-52 |
| 12 | 1 | Coil Housing Top | 05700-004-36-73 |
| 13 | 1 | Collar, Vent Scoop | 05700-004-36-71 |
| 14 | 1 | Curtain, 20 1/2" x 19" | 08415-002-14-41 |
| | | Curtain, HH 20 1/2" x 29 3/4" | 08415-004-49-64 |
| 15 | 1 | Baffle, Vent Cowl | 05700-002-11-47 |
| 16 | 5 | Screw, 1/4-20 x 5/8" Hex | 05305-274-24-00 |
| 17 | 10 | Screw, 10-32 x 1/2" | 05305-011-39-36 |
| 18 | 1 | Drip Tray | 05700-004-42-09 |
| 19 | 3 | Locknut, 1/4-20 Low Profile with Nylon Insert | 05310-374-02-00 |
| 20 | 2 | Bushing, 3/4" to 1/2" Hex, Brass | 04730-002-56-27 |
| 21 | 1 | Plumbing, Temperature Gauge, Coil | 05700-004-42-88 |
| 22 | 1 | Check Valve, 1/2" | 04730-004-79-79 |

Hoses for Energy Recovery System (Not Shown)

| DESCRIPTION | PART NUMBER |
|----------------------------|-----------------|
| Hose, Inlet (Blue) | 05700-004-42-29 |
| Hose, Coil Outlet (Red) | 05700-004-42-30 |
| Hose, Booster Outlet (Red) | 05700-004-42-31 |
| Hose, 1/2" x 23" (Blue) | 05700-004-42-32 |
| Hose, 1/2" x 47" (Red) | 05700-004-42-33 |
| Hose, 1/2" x 38" (Red) | 05700-004-42-34 |
| Hose, 1/2" x 5" (Blue) | 05700-004-42-89 |

Complete Steam Coil Assembly, L-R
05700-004-44-82

Complete Steam Coil Assembly, R-L
05700-004-46-30

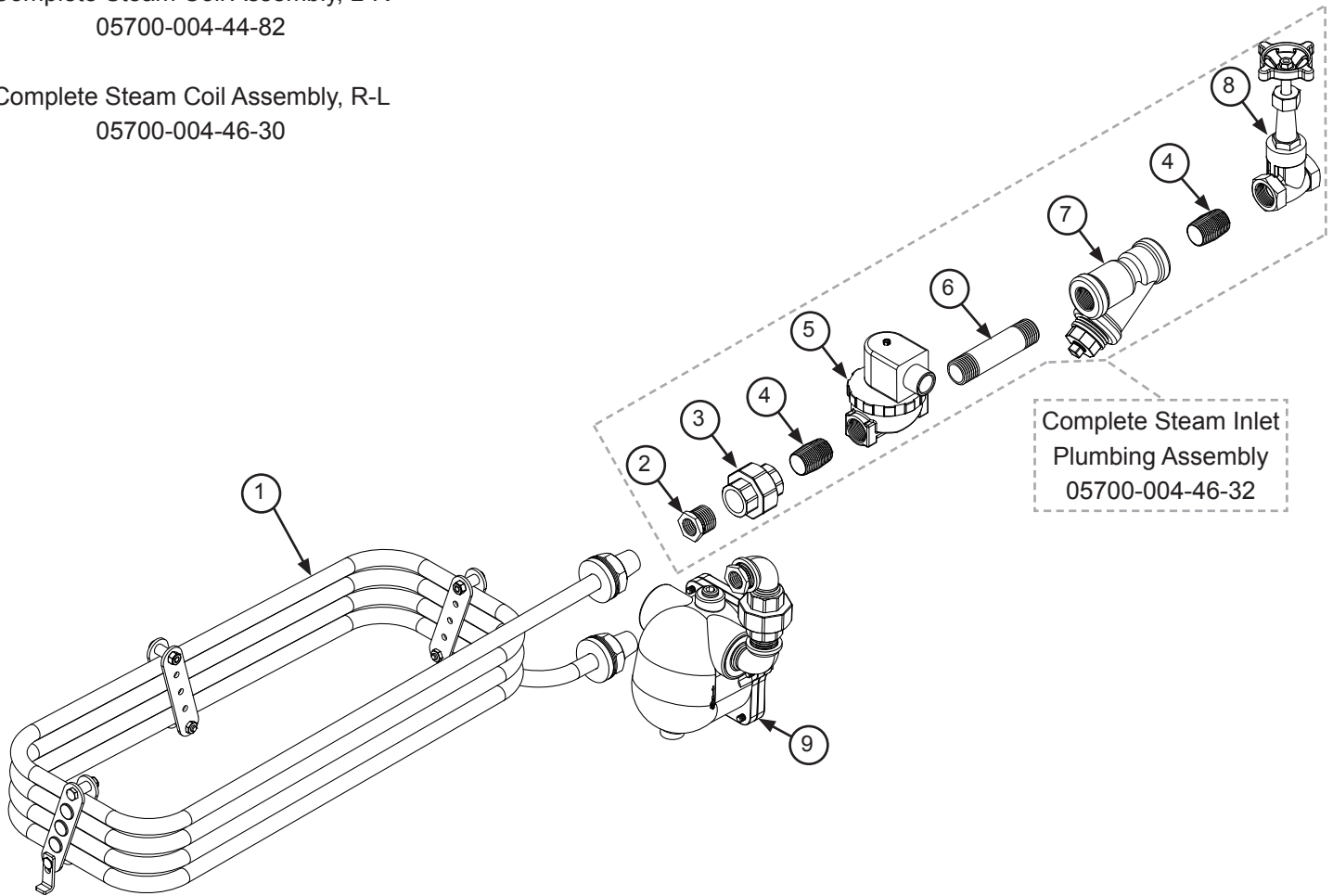

| ITEM | QTY | DESCRIPTION | PART NUMBER |
|------|-----|----------------------------------|-----------------|
| 1 | 1 | Steam Coil | 05700-004-36-15 |
| 2 | 1 | Reducer, 3/4" to 1/2" Black Iron | 04730-911-02-34 |
| 3 | 1 | Union, 3/4" Black Iron | 04730-912-01-00 |
| 4 | 2 | Nipple, 3/4" Black Iron | 04730-907-01-00 |
| 5 | 1 | Valve, Steam, 3/4" | 04820-011-87-39 |
| 6 | 1 | Nipple, 3/4" Black Iron, 4" Long | 04730-907-02-34 |
| 7 | 1 | Y-strainer, Steam, 3/4" | 04730-217-01-32 |
| 8 | 1 | Gate Valve, Steam, 3/4" | 04820-100-19-00 |
| 9 | 1 | Steam Condensate Assembly, L-R | 05700-004-46-56 |
| | 1 | Steam Condensate Assembly, R-L | 05700-004-46-33 |

Miscellaneous Parts

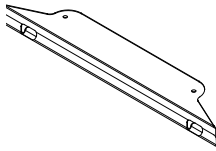

Curtain Bracket, Middle
05700-004-32-75



Curtain Bracket, End
05700-004-21-24

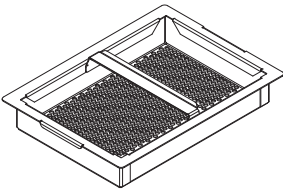

Strainer, Pre-wash
05700-004-69-74

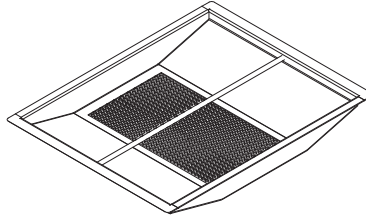

Strainer, Wash Tank 44
05700-004-29-02

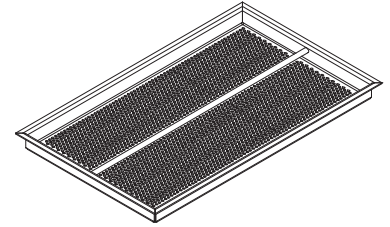

Strainer, Wash Tank 66
05700-004-09-43

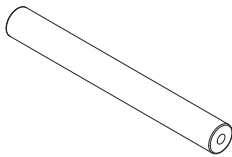

Pre-wash Connecting Rod
05700-004-56-16

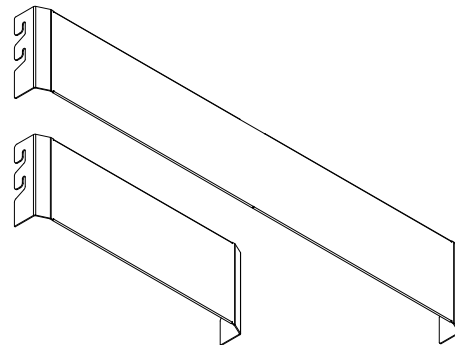

Ware Guide
05700-004-27-17
Pre-wash Ware Guide (66 Only)
05700-004-39-03

Options

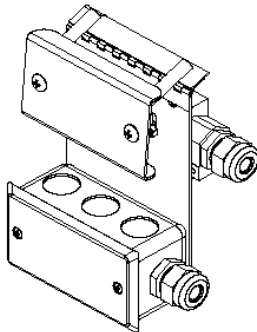

Striker Table Limit
Switch Option
05700-002-62-94

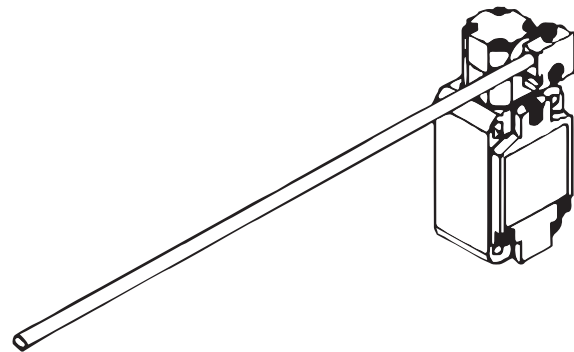

Whisker Table Limit
Switch Option
05700-002-06-83



RACKSTAR 44/66 SCHEMATIC

208/230/460 VOLTS, 50/60 Hz, 3-PHASE

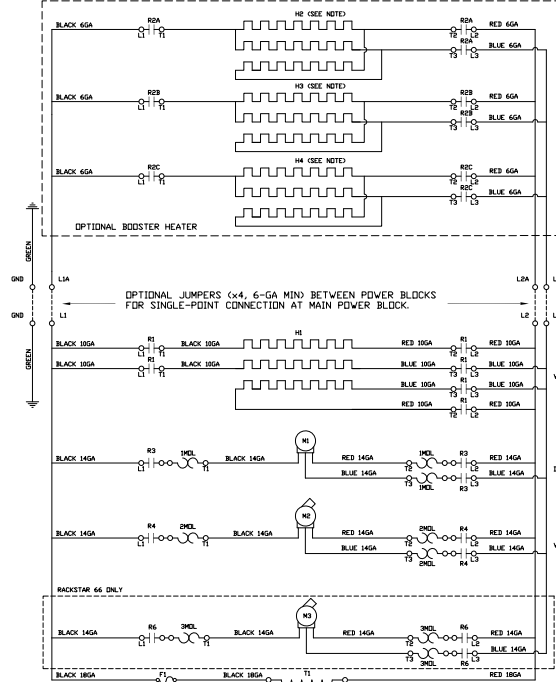

LEGEND

- L1 L2 L3 POWER DISTRIBUTION BLOCK (MAIN)
- L1A L2A L3A POWER DISTRIBUTION BLOCK (BOOSTER OPTION)
- GND EARTH GROUND
- R1 CONTACTOR, WASH HEATER
- R2A CONTACTOR, BOOSTER HEATER "BOTTOM"
- R2B CONTACTOR, BOOSTER HEATER "MIDDLE"
- R2C CONTACTOR, BOOSTER HEATER "TOP"
- R3 CONTACTOR, DRIVE MOTOR
- R4 CONTACTOR, WASH PUMP MOTOR
- R5 RELAY, RINSE
- R6 CONTACTOR, PRE-WASH PUMP MOTOR
- R7 RELAY, WASH TANK FILL
- R8 RELAY, DDDR SWITCH
- R9 CONTACTOR, WASH PUMP MOTOR
- H1 HEATER, WASH
- H2 HEATER, BOOSTER "BOTTOM"
- H3 HEATER, BOOSTER "MIDDLE"
- H4 HEATER, BOOSTER "TOP"
- M1 MOTOR, DRIVE
- M2 MOTOR, WASH PUMP
- M3 MOTOR, PRE-WASH PUMP
- IMDL OVERLOAD, DRIVE MOTOR
- 2MDL OVERLOAD, WASH PUMP MOTOR
- 2MDL# OVERLOAD, PRE-WASH PUMP MOTOR
- PWFS# PRE-WASH/FILL SOLENOID
- WFS WASH/FILL SOLENOID
- RS1 RINSE SOLENOID 1
- RS2 RINSE SOLENOID 2 (OPTION)
- S1 SWITCH, DDDR SAFETY (WASH)
- S2 SWITCH, DDDR SAFETY (WASH)
- S3 SWITCH, DDDR SAFETY (PRE-WASH)
- S4 SWITCH, WASH PUMP
- S5 SWITCH, WASH PUMP
- S6 SWITCH, WASH PUMP
- S7 SWITCH, FINAL RINSE
- S7# SWITCH, PRE-WASH PUMP
- PWFSW1M PRE-WASH FLOAT SWITCH 1 (UPPER)
- PWFSW2M PRE-WASH FLOAT SWITCH 2 (LOWER)
- WFSW1 WASH FLOAT SWITCH 1 (UPPER)
- WFSW2 WASH FLOAT SWITCH 2 (LOWER)
- HLRS HIGH-LIMIT 1-STAT, RINSE HEATER
- TLS TABLE LIMIT SWITCH (OPTION)
- TS1 THERMOSTAT, HIGH-LIMIT
- TRF TRANSFORMER, CONTROL
- F1 FUSE, CONTROL
- F2 FUSE, DETERGENT DISPENSER
- F3 FUSE, RINSE AID DISPENSER
- F4 FUSE, CONSTANT VOLTAGE CONNECTION
- F5 FUSE, EXHAUST FAN
- CVS CONSTANT VOLTAGE SIGNAL
- DET DETERGENT DISPENSER CONNECTION
- RAS RINSE AID SIGNAL
- TM TIMER, EXHAUST FAN

* DENOTES COMPONENTS SPECIFIC TO RACKSTAR 66
 NOTE: BOOSTER IS OPTIONAL, AND CAN SOMETIMES OPERATE AT A DIFFERENT VOLTAGE THAN MACHINE'S RATING. THIS IS TYPICALLY INDICATED BY A STICKER ON THE BOOSTER TERMINAL BLOCK.

Connection Diagram for IO Module

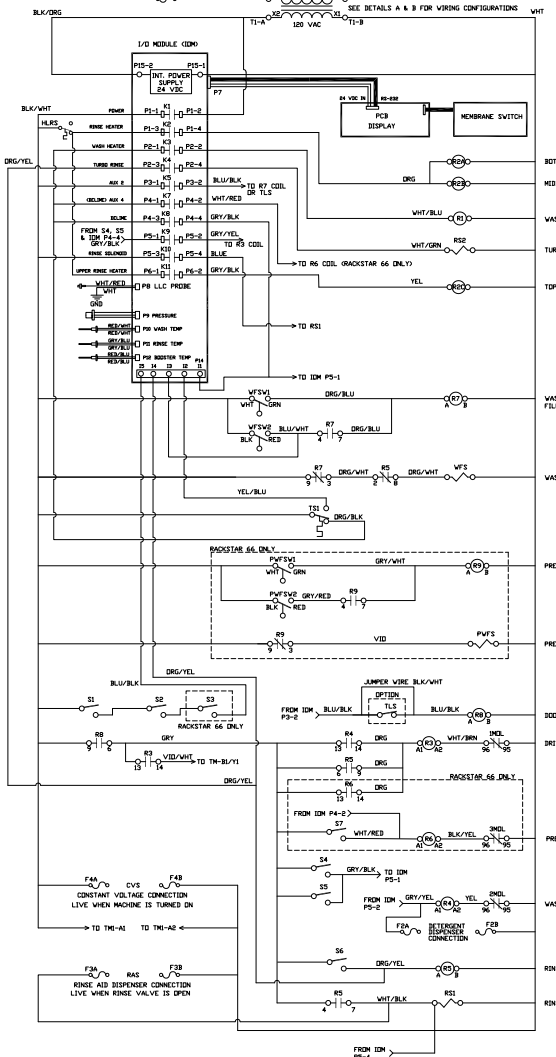
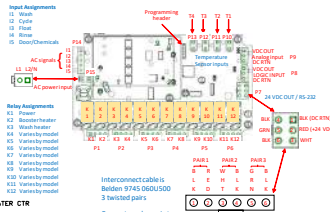

CONNECTORS SHOWN IN TOP VIEW (WIRE INSERTION END) CORRESPONDING CONNECTOR GOING TO DISPLAY PCB

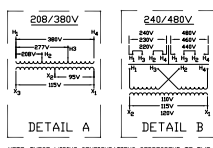
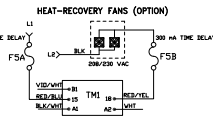

NOTE: THESE WIRING CONFIGURATIONS CORRESPOND TO TWO DIFFERENT TRANSFORMER TYPES.

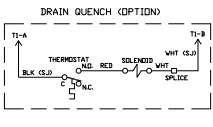
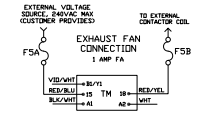

RACKSTAR 44/66 SCHEMATIC

208/230 VOLTS, 50/60 Hz, 1-PHASE

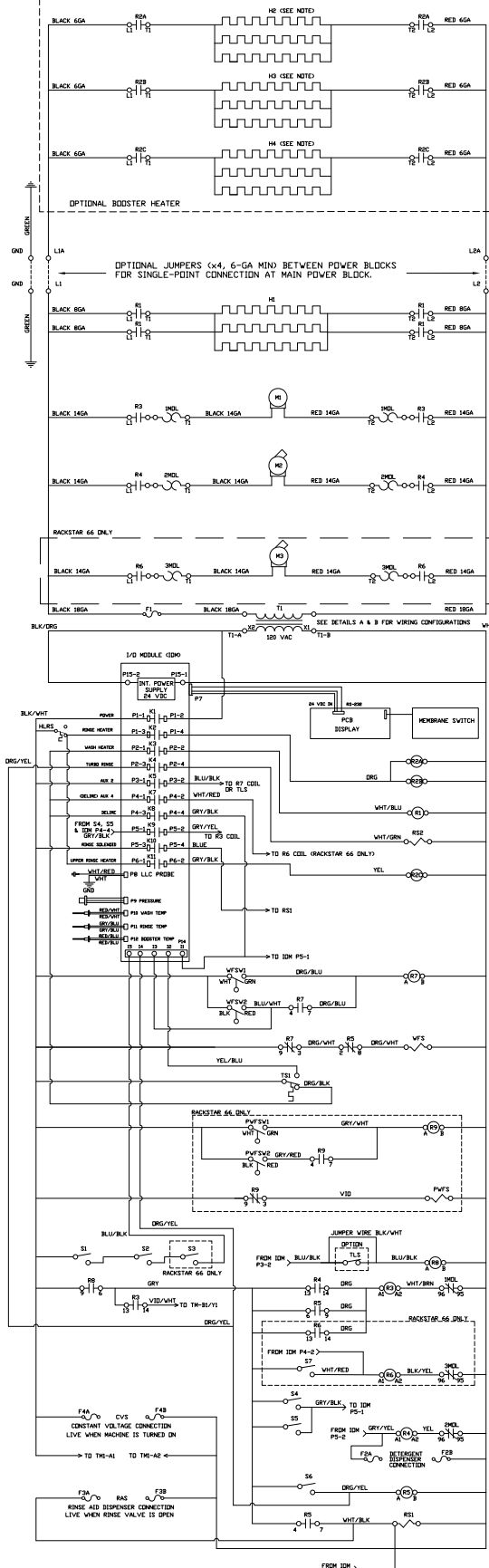

LEGEND

- L1 L2 L3 POWER DISTRIBUTION BLOCK (MAIN)
- L1A L2A L3A POWER DISTRIBUTION BLOCK (BOOSTER OPTION)
- GND EARTH GROUND
- R1 CONTACTOR, WASH HEATER
- R2A CONTACTOR, BOOSTER HEATER "BOTTOM"
- R2B CONTACTOR, BOOSTER HEATER "MIDDLE"
- R2C CONTACTOR, BOOSTER HEATER "TOP"
- R3 CONTACTOR, DRIVE MOTOR
- R4 CONTACTOR, WASH PUMP MOTOR
- R5 RELAY, RINSE
- R6M CONTACTOR, PRE-WASH PUMP
- R7 RELAY, WASH TANK FILL
- R8 RELAY, DOOR SWITCH
- R9M RELAY, PRE-WASH/FILL
- H1 HEATER, WASH
- H2 HEATER, BOOSTER "BOTTOM"
- H3 HEATER, BOOSTER "MIDDLE"
- H4 HEATER, BOOSTER "TOP"
- M1 MOTOR, DRIVE
- M2 MOTOR, WASH PUMP
- M3M MOTOR, PRE-WASH PUMP
- IMDL OVERLOAD, DRIVE MOTOR
- 2MDL OVERLOAD, WASH PUMP MOTOR
- 3MDLW OVERLOAD, PRE-WASH PUMP MOTOR
- PWF5W PRE-WASH/FILL SOLENOID
- WFS WASH/FILL SOLENOID
- RS1 RINSE SOLENOID 1
- RS2 RINSE SOLENOID 2 (OPTION)
- S1 SWITCH, DOOR SAFETY (WASH)
- S2 SWITCH, DOOR SAFETY (WASH)
- S3M SWITCH, DOOR SAFETY (PRE-WASH)
- S4 SWITCH, WASH PUMP
- S5 SWITCH, WASH PUMP
- S6 SWITCH, FINAL RINSE
- S7M SWITCH, PRE-WASH LIMIT
- PWFSW1X PRE-WASH FLDAT SWITCH 1 (UPPER)
- PWFSW2X PRE-WASH FLDAT SWITCH 2 (LOWER)
- WFSW1 WASH FLDAT SWITCH 1 (UPPER)
- WFSW2 WASH FLDAT SWITCH 2 (LOWER)
- HLSR HIGH-LIMIT 1-STAT, RINSE HEATER
- TLS TABLE LIMIT SWITCH (OPTION)
- TS1 THERMOSTAT, HIGH-LIMIT
- TI TRANSFORMER, CONTROL
- F1 FUSE, CONTROL
- F2 FUSE, DETERGENT DISPENSER
- F3 FUSE, RINSE AID DISPENSER
- F4 FUSE, CONSTANT VOLTAGE CONNECTION
- F5 FUSE, EXHAUST FAN
- CVS CONSTANT VOLTAGE SIGNAL
- DET DETERGENT DISPENSER CONNECTION
- RAS RINSE AID SIGNAL
- TM TIMER, EXHAUST FAN

* DENOTES COMPONENTS SPECIFIC TO RACKSTAR 66
 NOTE: BOOSTER IS OPTIONAL, AND CAN SOMETIMES OPERATE AT A DIFFERENT VOLTAGE THAN MACHINE'S RATING. THIS IS TYPICALLY INDICATED BY A STICKER ON THE BOOSTER TERMINAL BLOCK.

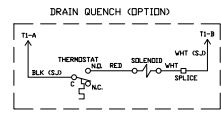
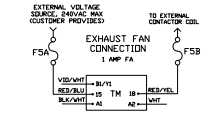
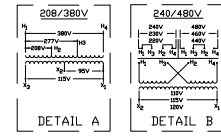
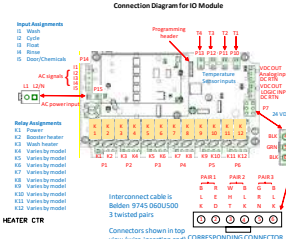

RACKSTAR STEAM 44/66 SCHEMATIC

208/230 VOLTS, 50/60 Hz, 3-PHASE

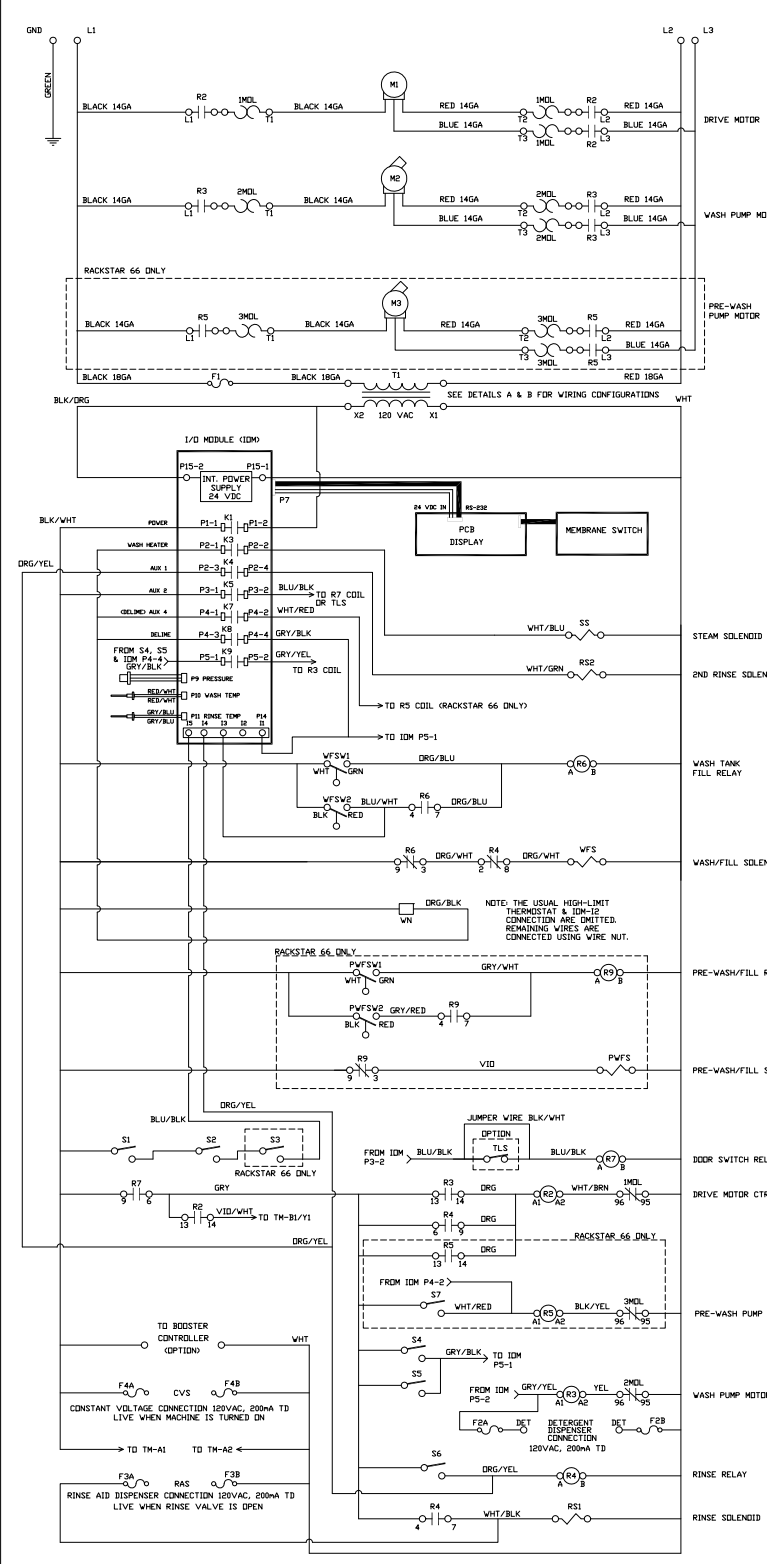

LEGEND

- L1 L2 L3 POWER DISTRIBUTION BLOCK (MAIN)
- L1A L2A L3A POWER DISTRIBUTION BLOCK (BOOSTER OPTION)
- GND EARTH GROUND
- R2 CONTACTOR, DRIVE MOTOR
- R3 CONTACTOR, WASH PUMP MOTOR
- R4 RELAY, RINSE
- R5* CONTACTOR, PRE-WASH PUMP MOTOR
- R6 RELAY, WASH TANK FILL
- R7 RELAY, DDR SWITCH
- R9* RELAY, PRE-WASH/FILL
- H1 HEATER, WASH
- H2 HEATER, BOOSTER (OPTION)
- M1 MOTOR, DRIVE
- M2 MOTOR, WASH PUMP
- M3* MOTOR, PRE-WASH PUMP
- 1MDL OVERLOAD, DRIVE MOTOR
- 2MDL OVERLOAD, WASH PUMP MOTOR
- 3MDL* OVERLOAD, PRE-WASH PUMP MOTOR
- PWFS* PRE-WASH/FILL SOLENOID
- WFS WASH/FILL SOLENOID
- RS1 RINSE SOLENOID 1
- RS2 RINSE SOLENOID 2 (OPTION)
- S1 SWITCH, DDR SAFETY (WASH)
- S2 SWITCH, DDR SAFETY (WASH)
- S3* SWITCH, DDR SAFETY (PRE-WASH)
- S4 SWITCH, WASH PUMP
- S5 SWITCH, WASH PUMP
- S6 SWITCH, FINAL RINSE
- S7* SWITCH, PRE-WASH LIMIT
- SS SOLENOID, STEAM VALVE
- PWFSW1* PRE-WASH FLDAT SWITCH 1 (UPPER)
- PWFSW2* PRE-WASH FLDAT SWITCH 2 (LOWER)
- WFSW1 WASH FLDAT SWITCH 1 (UPPER)
- WFSW2 WASH FLDAT SWITCH 2 (LOWER)
- TLS TABLE LIMIT SWITCH (OPTION)
- T1 TRANSFORMER, CONTROL
- F1 FUSE, CONTROL
- F2 FUSE, DETERGENT DISPENSER
- F3 FUSE, RINSE AID DISPENSER
- F4 FUSE, CONSTANT VOLTAGE CONNECTION
- F5 FUSE, EXHAUST FAN
- CVS CONSTANT VOLTAGE SIGNAL
- DET DETERGENT DISPENSER CONNECTION
- RAS RINSE AID SIGNAL
- TM TIMER, EXHAUST FAN
- WN WIRE NUT

* DENOTES COMPONENTS SPECIFIC TO RACKSTAR 66

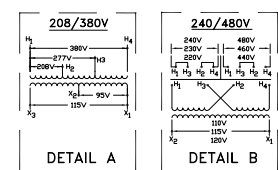
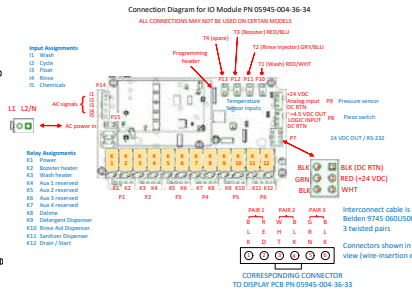

NOTE: THESE WIRING CONFIGURATIONS CORRESPOND TO TWO DIFFERENT TRANSFORMER TYPES.

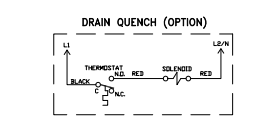
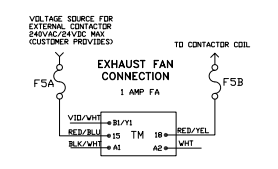

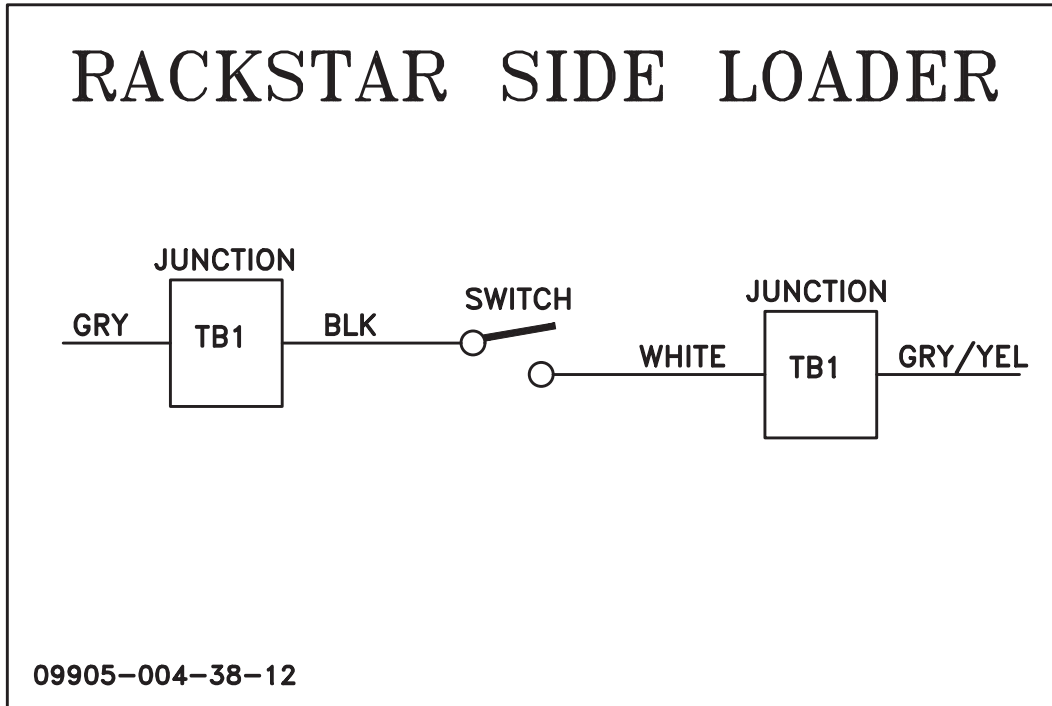

This page can be copied and the display templates cut-out. Lay the cut-out over the display and use the Up-arrow, Down-arrow, and Select Buttons to locate the hidden programming buttons.

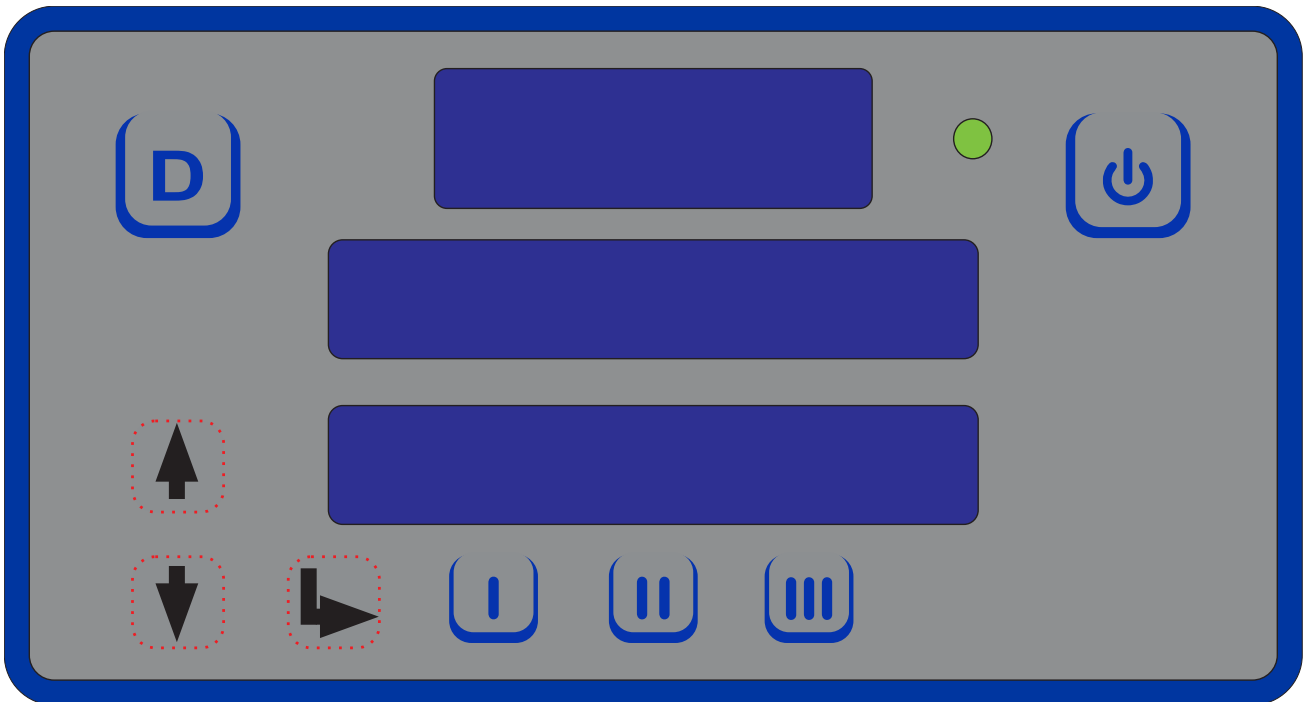
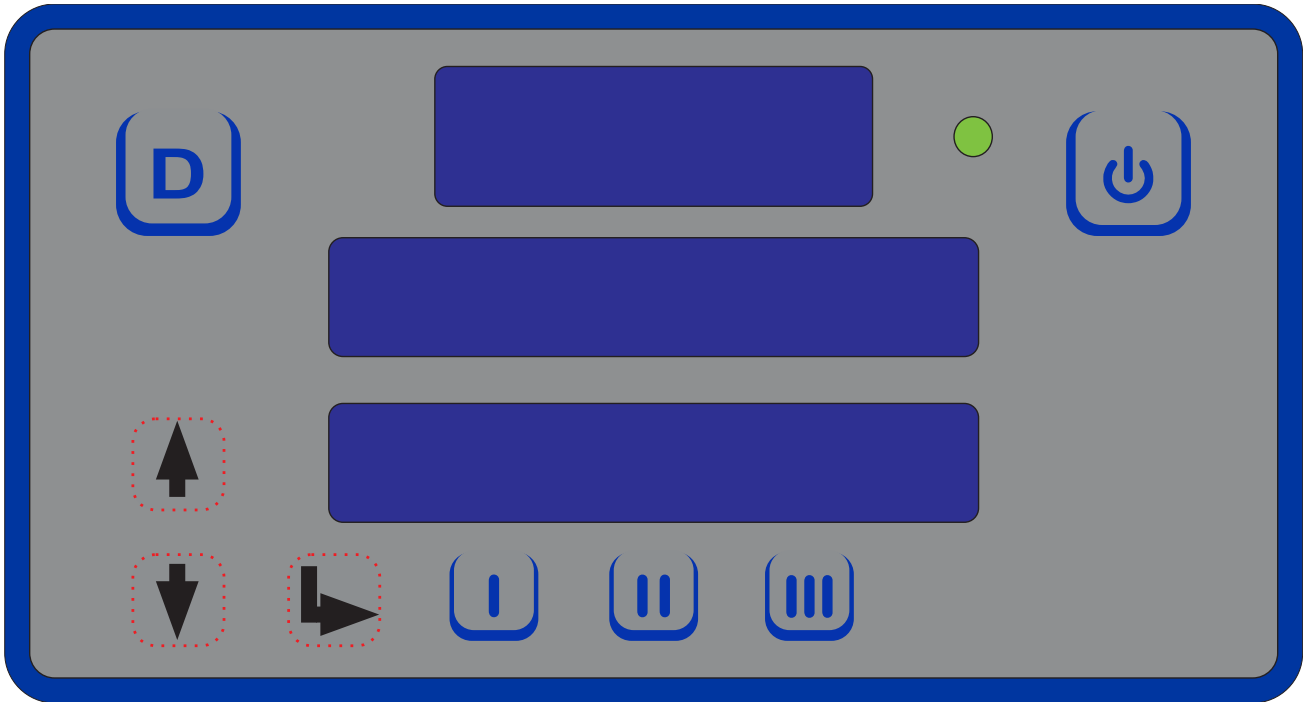

INSTALLATION, OPERATION, AND SERVICE MANUAL

RACKSTAR SERIES CONVEYOR DISHMACHINES



Jackson WWS, Inc. • 6209 N. US Hwy 25E • Gray, KY 40734 USA
1.888.800.5672 • www.jacksonwws.com

RackStar Manual • 07610-005-17-71-A