



*Conserver XL-E Series*  
*DOOR TYPE DISHMACHINES*

## INSTALLATION & OPERATION MANUAL

FOR JACKSON MODEL(S):  
**CONSERVER XL-E**





# **MANUFACTURERS WARRANTY**

## **ONE YEAR LIMITED PARTS & LABOR WARRANTY**

**ALL NEW JACKSON DISHWASHERS ARE WARRANTED TO THE ORIGINAL PURCHASER TO BE FREE FROM DEFECTS IN MATERIAL OR WORKMANSHIP, UNDER NORMAL USE AND OPERATION FOR A PERIOD OF (1) ONE YEAR FROM DATE OF PURCHASE, BUT IN NO EVENT TO EXCEED (18) EIGHTEEN MONTHS FROM DATE OF SHIPMENT FROM THE FACTORY.**

Jackson WWS agrees under this warranty to repair or replace, at its discretion, any original part which fails under normal use due to faulty material or workmanship during the warranty period, providing the equipment has been unaltered, and has been properly installed, maintained and operated in accordance with applicable factory instruction manual furnished with the machine and failure is reported to the authorized service agency within the warranty period. This includes the use of factory specified genuine replacement parts, purchased directly from a Jackson authorized parts distributor or service agency. Use of generic replacement parts may create a hazard and void warranty certification.

The labor to repair or replace such failed part will be paid by Jackson WWS, within the continental United States, Hawaii and Canada, during the warranty period provided a Jackson WWS authorized service agency, or those having prior authorization from the factory, performs the service. Any repair work by persons other than Jackson WWS authorized service agency is the sole responsibility of the customer. Labor coverage is limited to regular hourly rates; overtime premiums and emergency service charges will not be paid by Jackson WWS.

Accessory components not installed by the factory carry a (1) one year parts warranty only. Accessory components such as table limit switches, pressure regulators, pre-rinse units, etc. that are shipped with the unit and installed at the site are included. Labor to repair or replace these components is not covered by Jackson WWS.

This warranty is void if failure is a direct result from shipping, handling, fire, water, accident, misuse, acts of God, attempted repair by authorized persons, improper installation, if serial number has been removed or altered, or if unit is used for purpose other than originally intended.

### **TRAVEL LIMITATIONS**

Jackson WWS limits warranty travel time to (2) two hours and mileage to (100) one hundred miles. Jackson WWS will not pay for travel time and mileage that exceeds this, or any fees such as those for air or boat travel without prior authorization.

### **WARRANTY REGISTRATION**

To register your product go to [www.jacksonwws.com](http://www.jacksonwws.com) or call 1-888-800-5672. Failure to register your product will void the warranty.

### **REPLACEMENT PARTS WARRANTY**

Jackson replacement parts are warranted for a period of 90 days from date of installation or 180 days from the date of shipment from the factory, whichever occurs first.

### **PRODUCT CHANGES AND UPDATES**

Jackson WWS reserves the right to make changes in design and specification of any equipment as engineering or necessity requires.

THIS IS THE ENTIRE AND ONLY WARRANTY OF JACKSON WWS. JACKSON'S LIABILITY ON ANY CLAIM OF ANY KIND, INCLUDING NEGLIGENCE, WITH RESPECT TO THE GOODS OR SERVICES COVERED HEREUNDER, SHALL IN NO CASE EXCEED THE PRICE OF THE GOODS OR SERVICES OR PART THEREOF WHICH GIVES RISE TO THE CLAIM.

THERE ARE NO WARRANTIES, EXPRESSED OR IMPLIED, INCLUDING FOR FITNESS OR MERCHANTABILITY, THAT ARE NOT SET FORTH HEREIN, OR THAT EXTEND BEYOND THE DURATION HEREOF. UNDER NO CIRCUMSTANCES WILL JACKSON WWS BE LIABLE FOR ANY LOSS OR DAMAGE, DIRECT OR CONSEQUENTIAL, OR FOR THE DAMAGES IN THE NATURE OF PENALTIES, ARISING OUT OF THE USE OR INABILITY TO USE ANY OF ITS PRODUCTS.

### **ITEMS NOT COVERED**

THIS WARRANTY DOES NOT COVER CLEANING OR DELIMING OF THE UNIT OR ANY COMPONENT SUCH AS, BUT NOT LIMITED TO, WASH ARMS, RINSE ARMS OR STRAINERS AT ANYTIME. NOR DOES IT COVER ADJUSTMENTS SUCH AS, BUT NOT LIMITED TO TIMER CAMS, THERMOSTATS OR DOORS, BEYOND 30 DAYS FROM THE DATE OF INSTALLATION. IN ADDITION, THE WARRANTY WILL ONLY COVER REPLACEMENT WEAR ITEMS SUCH AS CURTAINS, DRAIN BALLS, DOOR GUIDES OR GASKETS DURING THE FIRST 30 DAYS AFTER INSTALLATION. ALSO, NOT COVERED ARE CONDITIONS CAUSED BY THE USE OF INCORRECT (NON-COMMERICAL) GRADE DETERGENTS, INCORRECT WATER TEMPERATURE OR PRESSURE, OR HARD WATER CONDITIONS.

# REVISION HISTORY

---

Revision Letter	Revision Date	Made By	Applicable ECNs	Details
A	01-06-14	MHH	8241	Release to production.
B	08-18-14	KAP	8305	Removed pg 17, updated part on page 20.
C	08-29-14	KAP	N/A	Updated part on pg. 27.
D	10-14-2014	KAP	N/A	Added 208 volt schematic on page 32. Updated available electrical characteristics on pg. 4. Updated Dimensions pg. 1 Updated part on pg. 29

# **Jackson<sup>®</sup>**

## ***Warewashing Systems***

### CONSERVER XL-E

Chemical sanitizing, single-rack, door type machine

Model: \_\_\_\_\_

Serial No.: \_\_\_\_\_

Installation Date: \_\_\_\_\_

Service Rep. Name: \_\_\_\_\_

Phone Number: \_\_\_\_\_

Jackson WWS, INC provides technical support for all of the dishmachines detailed in this manual. We strongly recommend that you refer to this manual before making a call to our technical support staff. Please have this manual with you when you call so that our staff can refer you, if necessary, to the proper page. Technical support is not available on holidays. Contact technical support toll free at 1-888-800-5672. Please remember that technical support is available for service personnel only.

# TABLE OF CONTENTS

---

## **SPECIFICATIONS**

Machine Dimensions .....	1
Table Dimensions .....	2
Operating Parameters .....	3
Electrical Requirements .....	4

## **INSTALLATION**

Instructions .....	7
False Panel Instructions .....	10
Operating Instructions .....	11
Delime Instructions .....	13

## **MAINTENANCE**

Preventative Maintenance .....	14
Troubleshooting .....	15
Solenoid Valve Instructions .....	17

## **PARTS**

Control Box Components .....	18
Chemical Feeder Pump Components .....	20
Hood Assembly .....	21
Door Assembly .....	22
Wash Arm Assembly .....	24
Wash Manifold Assembly .....	25
Tub Assembly .....	26
Wash Sump Assembly .....	27
Spillway Assembly .....	28
Pump & Motor Assembly .....	29
Frame Assembly .....	30
Miscellaneous .....	31

## **SCHEMATICS**

Electrical Schematics .....	32
-----------------------------	----

# SPECIFICATIONS

## MACHINE DIMENSIONS (Cons XL-E 115/60/1)

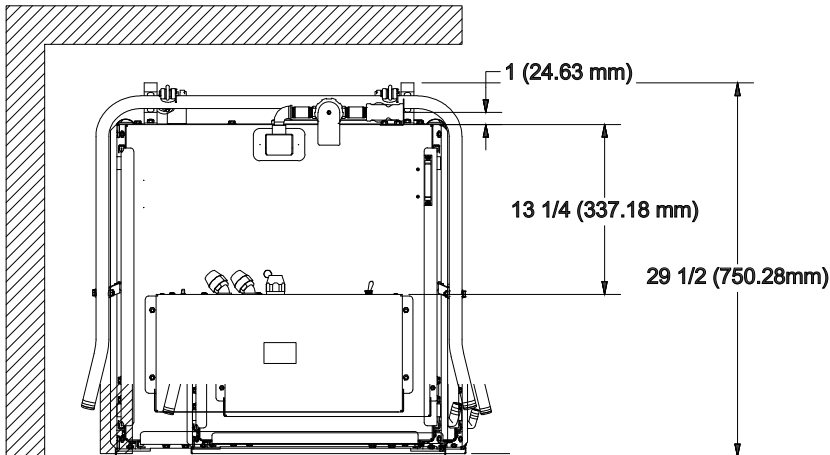

ALL VERTICAL DIMENSIONS ARE  
+/- 1/2" FROM FLOOR

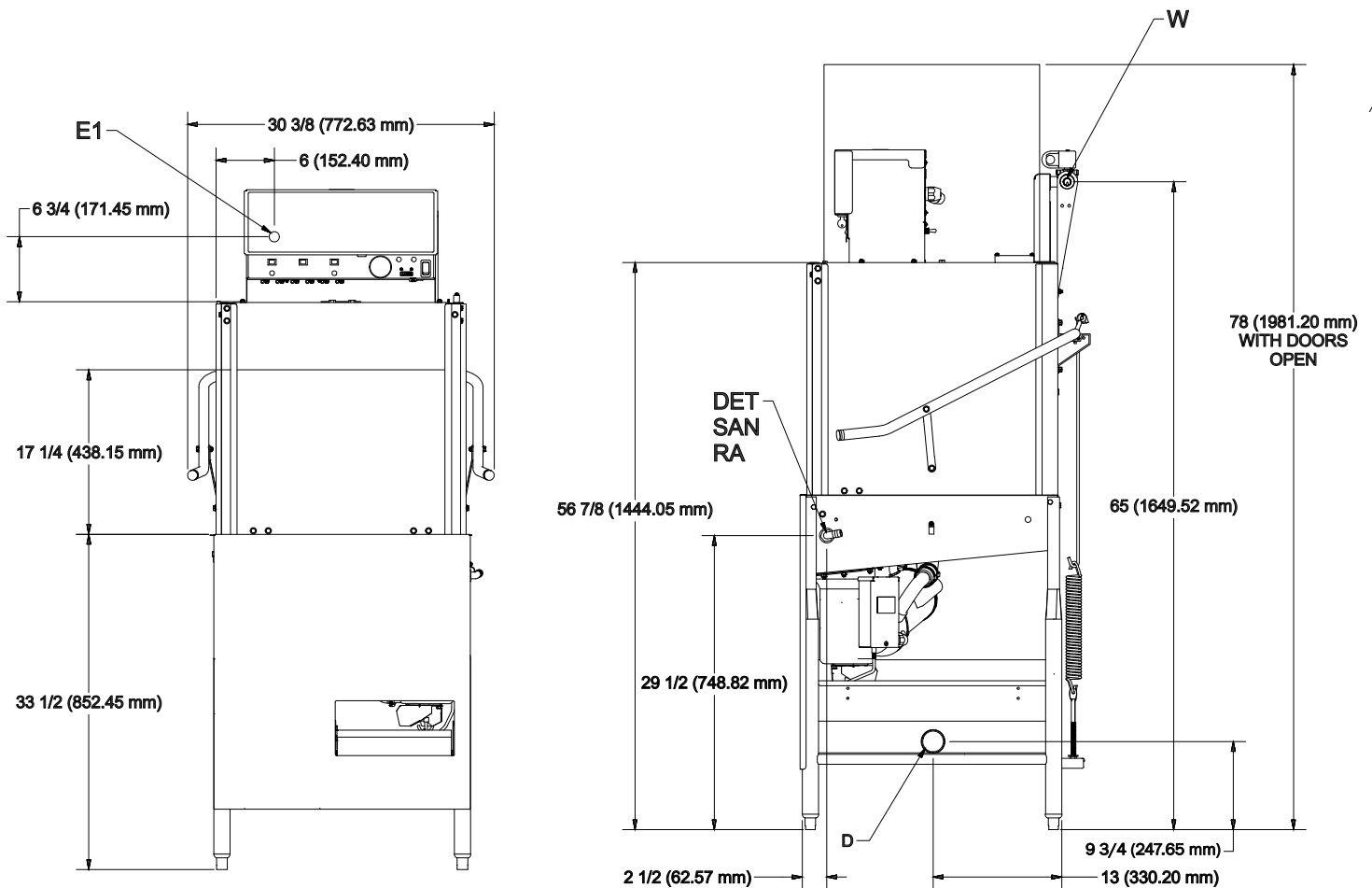

E1	MAIN ELECTRICAL CONNECTION (1.125" DIA HOLE) (Located on back of control box)
W	MAIN INLET WATER CONNECTION (1/2 NPT-F)
D	DRAIN CONNECTION (2" NPT-F)
DET	DETERGENT BULKHEAD ACCESS (.875" DIA HOLE)
SAN**	SANITIZER INLET

RA	RINSE AND INLET
CP	N/A
S*	N/A
C*	N/A
VI	N/A
V2	N/A

# SPECIFICATIONS

## TABLE DIMENSIONS

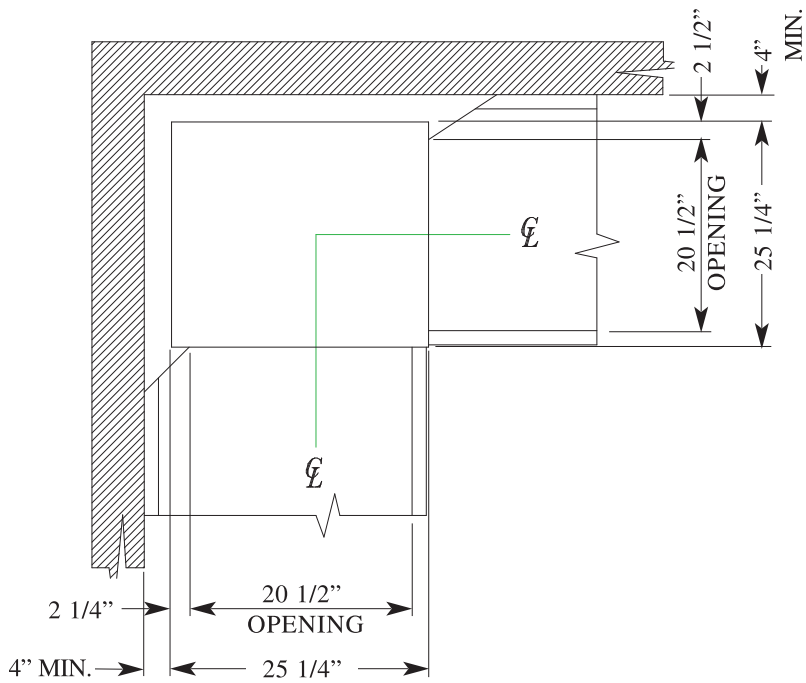

TABLE DIMENSIONS  
CORNER INSTALLATION

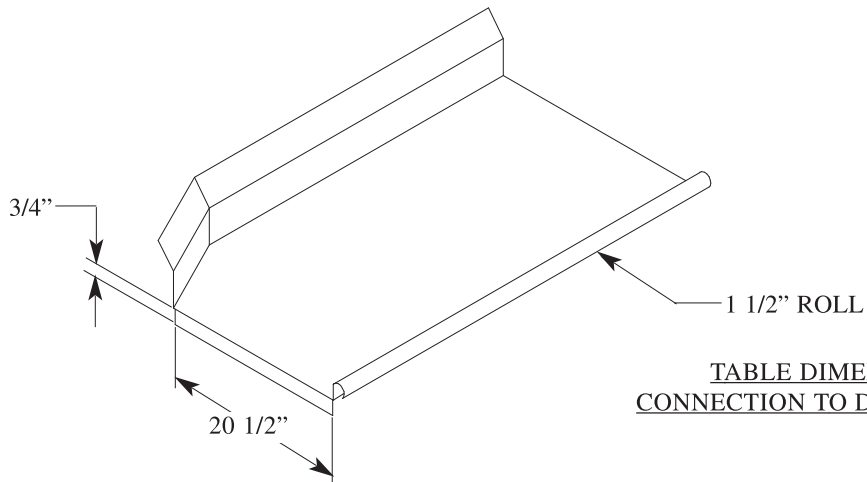

TABLE DIMENSIONS  
CONNECTION TO DISHWASHER

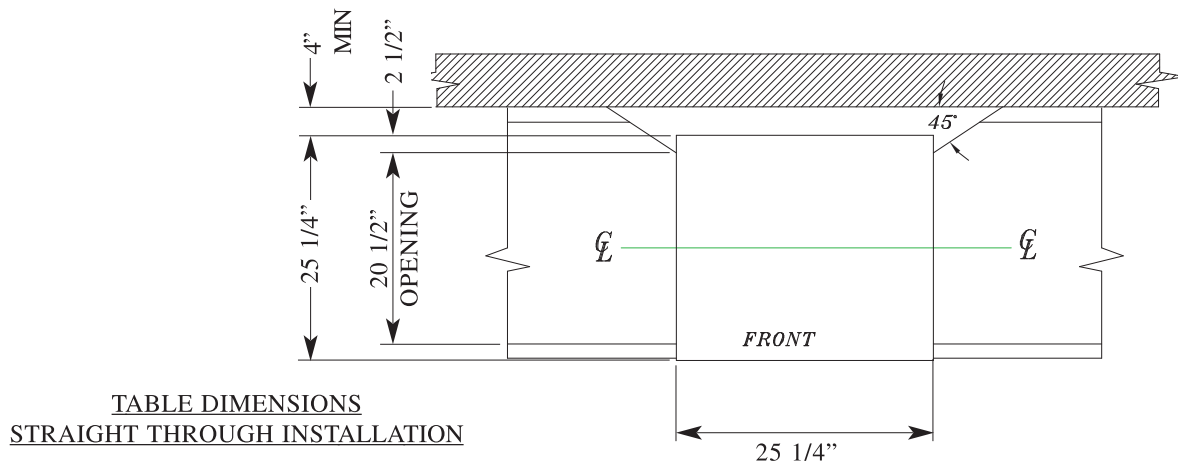

TABLE DIMENSIONS  
STRAIGHT THROUGH INSTALLATION

**Model Designation:** CONS XL-E

**Operating Capacity:**

Racks per Hour	39
Dishes per Hour	624
Glasses per Hour	1404

**Tank Capacity (Gallons):**

Wash Tank	1.44 (90 GPH)
-----------	---------------

**Electrical Loads (as applicable):**

Wash Motor HP	3/4
---------------	-----

**NOTE: Always refer to the machine data plate for specific electrical and water requirements. The material provided on this page is for reference only and is subject to change without notice.**

**CHEMICAL SANITIZING**

**Water Temperatures (Fahrenheit/Celsius):**

<i>Minimum Wash Temperature</i>	120/49
<i>Minimum Rinse Temperature</i>	120/49
<i>Incoming Water Temperature</i>	120/49

**Other Water Requirements:**

<i>Water Flow Pressure (PSI)</i>	15
<i>Flow Rate Minimum (GPM)</i>	1.03
<i>Water Line Size (NPT)</i>	1/2"
<i>Drain Line Size (NPT)</i>	2"
<i>Minimum Chlorine Required (PPM)</i>	50

# SPECIFICATIONS

## ELECTRICAL REQUIREMENTS

### CONS XL-E

Volts	Phase	Freq	Wash Motor Amps	Drive Motor Amps	Wash Heater Pumps	FLA	MCA	MOP
115	1	60	11.4	N/A	N/A	11.4	14.3	25.7

Note 1: MCA (Minimum Circuit Ampacity) = 125% x Largest Motor + FLA of all other motors + all other loads.

Note 2: MOP (Maximum Overcurrent Protective Device) = 225% x Largest Motor + FLA of all other motors + all other loads.

Note 3: All electrical ratings provided in this manual are for reference only. Always refer to the machine data plate to get the exact electrical information for your machine. All electrical work performed on machines should be done in accordance with applicable local, state, territorial and national codes. Work should only be performed by qualified electricians and authorized service agents. A list of authorized service agencies is located in the back of this manual.

Note that all electrical wiring used in the dishmachine must be rated, at a minimum, for 100°C (212°F). Furthermore, use copper conductors only.

Where applicable, heating element amperage draws have been adjusted for the assumed input voltage. Jackson assumes incoming voltages will be either 115, 208, 230 or 460 volts. Some of the heating elements used in our machines are actually rated for other voltages, such as 240 or 480 volts. Always verify the amperage draw of the machine in operation when sizing circuit protection.

The electrical configurations of the machines are as follows:

#### **Available Electrical Characteristics:**

- 115 volt, 60 Hz, single phase
- 115 volt, 50 Hz, single phase
- 230 volt, 60 Hz, single phase
- 220 volt, 60 Hz, single phase

**VISUAL INSPECTION:** Before installing the unit, check the container and the machine for damage. A damaged container may be an indication there is possible damage to the product. If there is any type of damage to both the container and the unit, DO NOT THROW AWAY THE CONTAINER. The dishmachine has been previously inspected at the factory and is expected to arrive to you in new, undamaged condition. However, rough handling by carriers or others may result in damage to the unit while it is in transit. If such a situation occurs, DO NOT RETURN THE UNIT TO THE MANUFACTURER. Instead, contact the carrier and ask them to send a representative to the site to inspect the damage. You should request that an inspection report be completed. You must contact the carrier within 48 hours of receiving the machine in order to report possible freight damage. You are also encouraged to contact the dealer through which you purchased the unit.

**UNPACKING THE MACHINE:** The machine should be unboxed and removed from the pallet prior to installing. Open the front door and remove all of the materials from the inside. Once unpacked, verify there are no missing parts. If you discover a part is missing, contact Jackson immediately.

**LEVEL THE DISH MACHINE:** The dishmachine is designed to operate while level. This is important to prevent any damage to the machine during operation and to ensure the best results possible. The unit comes equipped with adjustable bullet feet, which can be turned using a pair of pliers. Verify the unit is level from front to back and side to side prior to making any electrical or plumbing connections.

**PLUMBING THE MACHINE:** All plumbing connections must be made to adhere to local, state, territorial and national codes. The installing plumber is responsible for ensuring the incoming water lines are flushed of debris prior to connecting to the machine. Note that chips and materials from cutting processes can become lodged in the solenoid valves and prevent them from opening or closing. Any valves that are found to be fouled or defective because of foreign matter left in the water line, and any subsequent water damage, are not the responsibility of the manufacturer.

Water hardness should be a maximum of 6 grains per gallon. Hard water should be treated prior to being used by the machine. Iron in the water line can cause staining. A filter designed to remove iron from the water supply is highly recommended for supplies in excess of 0.1 ppm.

The water supply line shall be ½" NPT minimum and must be able to provide water at the minimum temperature indicated on the machine data plate.

The unit utilizes a flow pressure of 15 PSI for the incoming water line. Do not confuse static pressure with flow pressure. Static pressure is the pressure present when there is no flow and the valves are closed; flow pressure is present when the water is running into the machine. In areas where pressure fluctuates or is greater than the recommended pressure, it is suggested that a water pressure regulator valve be installed.

It is recommended that a shut-off valve be installed to allow isolating the dishmachine from the water system in the event that maintenance or other activities are required. Also, it is suggested that a shock absorber (**not supplied** with dishmachine) be installed on the incoming water line. This prevents water hammer (hydraulic shock)—induced by the solenoid valve as it operates—from causing damage to the equipment.

**CONNECTING THE DRAIN LINE:** The drain for the unit is a gravity discharge drain. All piping to the machine drain must be a minimum 2" NPT AND SHALL NOT BE REDUCED. There must also be an air gap between the machine drain line and the floor sink or drain. If a grease trap is required by code, it should have a flow capacity of 5 gallons.

# INSTALLATION

---

## INSTRUCTIONS

**ELECTRICAL POWER CONNECTIONS:** All electrical connections are to be made in accordance with applicable portions of local, state, territorial and national codes.

**DISCONNECT ELECTRICAL POWER SUPPLIES AND TAG OUT IN ACCORDANCE WITH APPROPRIATE PROCEDURES AND CODES AT THE DISCONNECT SWITCH TO INDICATE YOU ARE WORKING ON THAT CIRCUIT.**

This manual provides reference information regarding electrical requirements and loads, but that information may change without notice. Always refer to the machine data plate for voltage requirements, machine voltage, total amperage load and serial number. If you cannot read your data plate because it has been damaged, you should contact the manufacturer.

The main power terminal blocks (for the dishmachine and for the rinse booster heater, if applicable) are located at the top of the machine. You will have to remove the top cover to access these connections. Route incoming power lines within conduit that will connect via fittings to the pre-punched holes in the back of the Control Box. Install power and ground wires to lugs as indicated by the appropriate decals in the control box. Use copper conductors only. Use of an anti-oxidation agent is permissible on the power connections. Tighten all connections.

Verify the incoming voltage matches the voltage indicated on the decal next to the incoming power pre-punched hole.

**DISHMACHINE VENTILATION:** The dishmachine should be located into an adequate exhaust hood or ventilation system with provisions for venting. This is essential to permit efficient removal of the condensation exhaust. Ensure the exhaust system is acceptable in accordance with applicable codes and standards.

**Note:** Any damage that is caused by steam and/or moisture due to improper ventilation is NOT covered under the warranty.

The dishmachine has the following ventilation requirements: **200 CFM**

The exhaust system must be sized to handle this volume for the dishmachine to operate in the manner it was designed.

**THERMOSTATS:** The thermostats on your unit have been set at the factory for the wash tank. They should only be adjusted by an authorized service agent.

**TO PREPARE CHEMICAL PUMPS FOR OPERATION:** The Conserver XL-E dishmachine is supplied with detergent, rinse additive and sanitizer-dispensing chemical feeder pumps. Locate the open ends of the chemical tubes with the tube stiffeners and place each one in the appropriate container.

**A. Red Tubing = Detergent    B. Blue Tubing = Rinse Aid    C. White Tubing = Sanitizer**

**PRIMING CHEMICAL FEEDER PUMPS:** Chemical feeder pumps need priming when the machine is first installed or if the chemical lines have been removed and air is allowed to enter.

**CAUTION: Water must be in the sump and wash tank prior to the dispensing of chemicals. Sanitizer in concentration is caustic and may cause damage without dilution.**

1. Verify that the proper chemical tube stiffener inlet is in the proper container.
2. Use the toggle switches on the front of the control box to prime each pump. There are 3 switches mounted by the peristaltic pumps. One will prime the sanitizer pump only, the second will prime the detergent and the third will prime the rinse aid pump.
3. To prime the pumps, hold the switch in the momentary position until the chemical can be observed entering the sump.
4. Detergent is dispensed as required by the timer during the wash cycle. The amount of detergent may need to be increased or decreased depending on water quality and type of detergent.
5. Rinse additive is dispensed as required into the final rinse. The amount of rinse aid may need to be adjusted depending on water hardness and results.
6. Sanitizer is dispensed into the final rinse. The amount of sanitizer may need to be adjusted depending on the concentration and type of sanitizer used.
7. Please refer to the next page for instruction on adjusting the chemical feeder pumps on the CAM timer.

**WARNING: Some of the chemicals used in dishwashing may cause chemical burns if they come in contact with your skin. Wear protective gear when handling these chemicals. If you do come in contact with these chemicals, immediately flush the affected area with fresh water. Always refer to the chemical agent packaging for safe handling and first-aid instructions.**

# INSTALLATION

---

## CAM TIMER OPERATION

The Conserver XL-E Series CAM timer is a 1 minute, 30 second, 8-CAM timer (**CAM 8 is a spare**) that controls the operation of the dishmachine. The following is a description of the set points for each CAM and the function of each switch.

### **CAM 1 is a cut CAM with a single notch that serves as the cycle/reset control.**

FUNCTION: When the machine is in the operation mode the notch is in the home position. The machine will remain idle until the door is opened, then CAM 1 moves to the start position and holds until the door is closed. The closing of the door will start the next cycle. The CAM will rotate a complete cycle and return to the home position and hold.

### **CAM 2 is a cut CAM that provides the wash cycle timing.**

FUNCTION: The wash CAM works off the normally open contacts of CAM 2. This requires the microswitch be held closed by the CAM. It will close and energize the wash pump 2 seconds after the cycle switch is activated. The pump will operate through the wash cycle (40 seconds) then shut down for the dwell period (20 seconds). As the CAM rotates it energizes the pump for the rinse cycle (25 seconds). When CAM 1 reaches its home position it will de-energize CAM 2, shutting down the wash pump.

***NOTE: The last 6 CAMS are adjustable. The following instructions will require that the timer position have the CAMs to the front and the motor to the left.***

### **CAM 3 is an adjustable CAM that controls the drain valve.**

FUNCTION: The drain solenoid works off the normally closed contacts of CAM 3. When the cycle is initiated, the microswitch will be held open until it is allowed to drop into the notch of the CAM. This energizes the drain solenoid which then drains the machine. After a 12 second delay the CAM reverses the microswitch, de-energizing the drain solenoid. This CAM may require adjusting due to varying water pressure. The drain solenoid must remain open long enough to remove whatever water the fill valve solenoid allows in the machine. This could vary due to the water supply line pressure.

SETTINGS: The right side of CAM 3 must be set to pick up the microswitch just before the wash/rinse cycle CAM switch drops. It will hold the drain solenoid open to drain all the water in the tank from the unit during the dwell period. Any adjustment made to the drain should be made to the left side of CAM 3. The CAM must be moved back into the wash time until all of the water is drained from the machine.

### **CAM 4 is an adjustable CAM that controls the fill valve and the amount of water used.**

FUNCTION: The fill valve CAM works off the normally closed contacts of CAM 4. This requires the microswitch to be held open by the CAM and allowed to drop into the notch to operate the fill valve. This energizes the fill solenoid which opens to start filling the machine with fresh water. After a 10 second delay the CAM reverses the microswitch, de-energizing the fill solenoid. The fill CAM may require adjustment due to varying water pressure. The fill solenoid must remain open a sufficient length of time to fill the machine to the correct level.

SETTINGS: The right side of CAM 4 must be set to allow the microswitch to drop 2 seconds before the drain solenoid is de-energized to ensure the detergent residue is flushed from the unit. It will hold the fill solenoid open until the CAM switch arm is raised. At that time the fill solenoid is de-energized, shutting off the incoming water. The tub will be filled to the correct level. Any adjustment made to the timing of the fill solenoid should be made with the left side of CAM 4. To increase the water level, open the notch of the CAM; to decrease, the notch should be closed.

**CAM 5 is an adjustable CAM that controls the sanitizer pump.**

FUNCTION: The sanitizer pump CAM works off the naturally closed contacts of CAM 5. This requires the microswitch to be held open by the CAM and allowed to drop into the notch to operate the pump. The time that the sanitizer pump will remain energized must be determined in the field to suit water conditions and the chemical used.

SETTINGS: The left side of CAM 5 must be set to allow the microswitch to drop in past the starting point of the fill CAM and after the drain solenoid has closed. The adjustment for sanitizer volume must be made with the right side of the CAM. To increase the volume the notch should be increased. To decrease, the notch should be closed slightly in increments until the correct level is reached.

**CAM 6 is an adjustable CAM that controls the detergent pump.**

FUNCTION: The detergent pump CAM works off the normally closed contacts of CAM 6. This requires the microswitch to be held open by the CAM and allowed to drop into the notch to operate the pump. The time that the detergent pump will remain energized must be determined in the field to suit water conditions and the chemical used.

SETTINGS: The left side of CAM 6 must be set to drop in past the starting point of the wash pump CAM. The adjustment for detergent volume must be made with the right side of the CAM. To increase the volume, the notch should be increased. To decrease, the notch should be closed slightly in increments until the correct level is reached.

**CAM 7 is an adjustable CAM that controls the rinse aid pump.**

FUNCTION: The rinse aid pump CAM works off the normally closed contacts of CAM 7. This requires the microswitch to be held open by the CAM and allowed to drop into the notch to operate the pump. The time that the rinse aid pump will remain energized must be determined in the field to suit water conditions and the chemical used.

SETTINGS: The left side of CAM 7 must be set to drop in past the starting point of the fill CAM after the drain solenoid has closed. The adjustment for rinse aid volume must be made with the right side of the CAM. To increase the volume the notch should be increased. To decrease, the notch should be closed slightly in increments until the correct level is reached.

**CAM 8 is a spare.**

# INSTALLATION

## FALSE PANEL INSTRUCTIONS

False Panel Weldment  
05700-002-51-66

False Panel Kit  
05700-003-12-93

Rack rail removed and repositioned  
for a corner operation

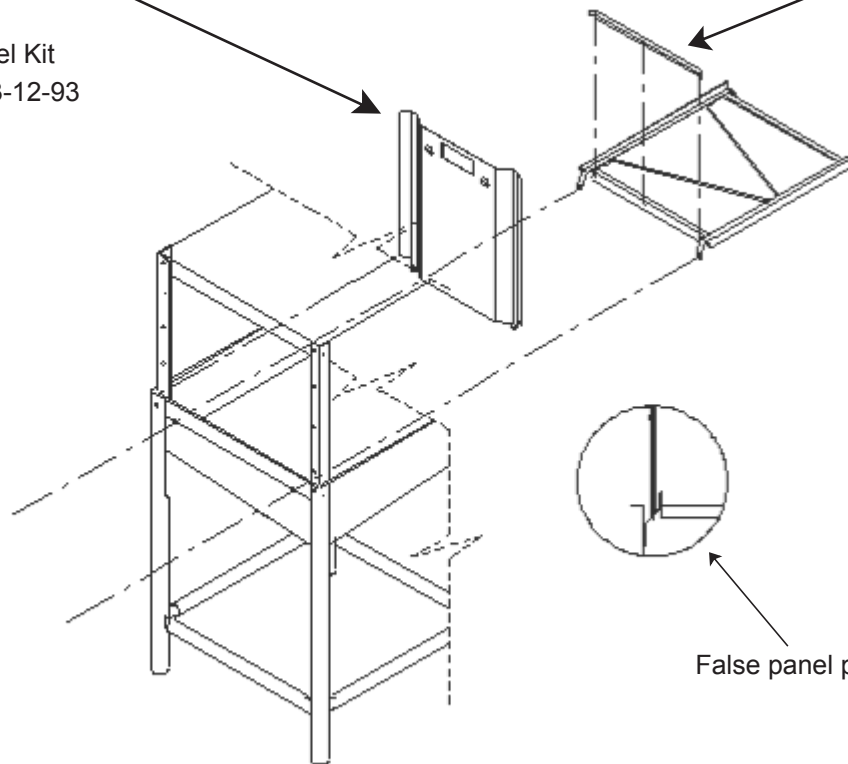

False panel positioned in unit

Insert this side first

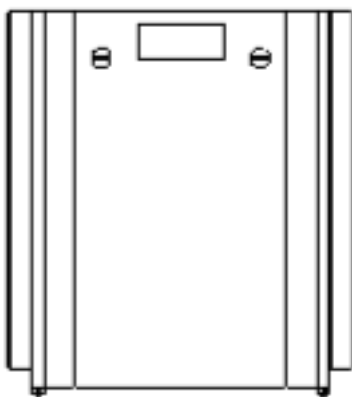

Bottom of side panel

1. Loosen the rack assembly from the unit.
2. False panel will mount to the rack inside the dishmachine.
3. Position panel in unit on side to be closed.
4. Hold panel against side of dishmachine and push up.
5. Panel will clip inside the unit under the edge of the hood.
6. Holes in false panel will line up with rack assembly holes.
7. Re-install screws for rack assembly which will secure false panel to unit.
8. Re-assemble the rack track in an "L" shape for a corner operation.

**PREPARATION:** Before proceeding with the start-up of the unit, verify the following:

- The sump strainer is in place and is clean.
- The drain stopper is installed.
- The strainers are installed.

**POWER UP:** To place the unit in standby, press the START button on the front of the machine.

**FILLING THE WASH TUB:** For the initial fill, close doors and depress and hold the OFF/ON/FILL rocker switch in the FILL position for approximately 8-10 seconds. Open the doors and verify that the water level is correct. Water must be between two lines on drain stopper pipe. Hereafter, the water level is controlled by the timer that has been preset at the factory. Verify that the drain stopper is preventing the wash tub water from pouring out excessively. There may be some slight leakage from the drain hole. Verify that there are no other leaks on the unit before proceeding any further. The wash tub must be completely filled before operating the wash pump to prevent damage to the component. Once the wash tub is filled, the unit is ready for operation.

The water level is controlled by the timer that has been preset at the factory.

To increase or decrease the water level, close the door and turn the power circuit breaker on. Open and close the door to run a cycle, then check the water level. Adjust as necessary and close the control box cover. The machine runs a complete cycle to drain and fill. If the machine is not allowed to drain, the water will build up inside the tub. After the initial fill, the rinse water for the current cycle will become the wash water for the next cycle.

**FIRST RACK:** The first rack of ware that you place into the unit usually has the effect of very quickly reducing the temperature of the wash tank. This is because you are introducing cold materials into the dishmachine environment and the unit has to circulate water to activate the heating cycle. You may have to run the first rack through the unit again. Any time the unit has not been operated for an extended period of time this is possible, but unlikely. This is usually dependent on the type of ware you are using, its temperature and the ambient temperature of the kitchen area. To ensure proper operation, always observe the temperatures of the wash and rinse when first starting the unit.

**WARE PREPARATION:** Proper preparation of ware is essential for the smooth, efficient operation of your dishmachine. If done properly, you can expect to have fewer re-washes and use substantially less detergent. Any ware placed inside the machine should have all solid food waste and scraps removed. It is recommended that ware also be sprayed down prior to entry into the dishmachine.

Place cups and glasses upside down in racks so they do not hold water during the cycle. Presoak flatware in warm water to assist in removing food. Load plates and saucers in the same direction, with the food surface facing the unload end of the machine.

# INSTALLATION

---

## OPERATING INSTRUCTIONS

**WASHING A RACK OF WARE:** To wash a rack, open the doors completely (beware of hot water dripping from the doors) and slide the rack into the unit. Close the doors and the unit will start automatically. Once the cycle is completed, open the door (again careful of the dripping hot water) and remove the rack of clean ware. Replace with a rack of soiled ware and close the doors. The process will then repeat itself.

**OPERATIONAL INSPECTIONS:** Based upon usage, the pan strainer may become clogged with soil and debris as the workday progresses. Operators should regularly inspect the pan strainer to ensure it has not become clogged. If the strainer becomes clogged, it will reduce the washing capability of the machine. Instruct operators to clean out the pan strainer at regular intervals or as required by work load.

**SHUTDOWN AND CLEANING:** At the end of the workday, close the doors. When the unit completes the cycle, turn the power switch to the OFF position and open the doors. Manually remove the drain stopper from the tub and allow the tub to drain (CAUTION: Wash tank water will be hot!). Once the wash tub is drained, remove the pan strainer and the pump suction strainer. Remove soil and debris from the strainer and set to the side. Unscrew the wash and rinse arms from their manifolds. Remove the endcaps and flush the arms with water. Use a brush to clean out the inside of the arms. If the nozzles appear to be clogged, use a toothpick to remove the obstruction. Wipe the inside of the unit out, removing all soil and scraps. Reassemble the wash and rinse arms and replace them in the unit. The arms only need to be hand tight, do not use tools to tighten them down. Reinstall the strainers and close the doors.

To proceed with the delime operation, fill the dishmachine with the correct amount of delime solution as recommended by the manufacturer of the chemicals. The tank capacities of the machine can be found in the Specifications section of this manual.

After the chemicals are added, perform the following steps:

1. Flip the NORMAL/DELIME Toggle Switch to DELIME. (NOTE: The Delime Switch is located on the back of the control box)
2. Disconnect or turn off chemical feeder pumps.
3. Close all doors.
4. Press the Power Switch and run the machine for the length of time required by the chemical solution manufacturer.
5. Press the Power Switch to shut the unit off.
6. Open the door and step away for 5 minutes.
7. Inspect the inside of the unit to determine if your expectations have been met. If not, you may need to run the delime solution through the unit for more time.
8. Once clean, drain the machine completely.
9. Close the door.
10. Refill the unit.
11. Press the Power Switch and run the unit in Manual for 10 minutes.
12. Press the Power Switch to turn off the unit.
13. Open the front door.
14. Drain the unit.
15. Flip the NORMAL/DELIME Switch to NORMAL.
16. Your machine is ready to use.

**This equipment is not recommended for use with deionized water or other aggressive fluids. Use of deionized water or other aggressive fluids will result in corrosion and failure of materials and components. Use of deionized water or other aggressive fluids will void the manufacturer's warranty.**

# MAINTENANCE

---

## PREVENTATIVE MAINTENANCE

The dishmachine covered in this manual is designed to operate with a minimum of interaction with the operator. However, this does not mean that some items will not wear out in time. Jackson highly recommends that any maintenance and repairs not specifically discussed in this manual should be performed by **QUALIFIED SERVICE PERSONNEL ONLY**. Performing maintenance on your dishmachine may void your warranty if it is still in effect.

There are many things that operators can do to prevent catastrophic damage to the dishmachine. One of the major causes of component failure involves pre-scraping procedures. A dishmachine is not a garbage disposal; any large pieces of material that are put into the machine shall remain in the machine until they are either broken up (after spreading out on your ware!) or physically removed. Strainers are installed to help catch debris, but they do no good if they are clogged. Have operators regularly inspect the pan strainers to ensure (1) that they are free of soil and debris and (2) they are laying flat in the tub.

When cleaning out strainers, do NOT beat them on waste cans. The strainers are made of metal but once severe damage is done, it will not work properly. Wipe out strainers with a rag and rinse under a faucet if necessary. For stubborn debris, a toothpick can be used to dislodge any obstructions from the perforations. Always ensure that strainers are placed back in the machine before operation and that they lay flat in the tub.

Refer to the section titled "Plumbing the Machine" (page 5) to learn more about how your water hardness will effect the performance of your machine. Hard water makes dishmachines work harder and decreases efficiency.

Again, it is important to remind operators that attempting corrective maintenance on the dishmachine could lead to larger problems or even cause harm to the operator. If a problem is discovered, secure the dishmachine using proper shut down procedures as listed in this manual and contact a **QUALIFIED SERVICE AGENCY**.

Some problems may not begin with the machine. One common problem occurs when temperatures are too low. Verify that the water temperatures coming to your dishmachine match the requirements listed on the machine data plate. There can be a variety of reasons why your water temperature is too low and you should discuss it with a **QUALIFIED SERVICE AGENCY** to determine what can be done.

By following the operating and cleaning instructions in this manual, you should get the most efficient results from your machine. As a reminder, here are some steps to ensure that you are using the dishmachine the way it was designed to work:

1. Ensure that the water temperatures match those listed on the machine data plate.
2. Ensure that all strainers are in place before operating the machine.
3. Ensure that all wash and/or rinse arms are secure in the machine before operating.
4. Ensure that drains are closed/sealed before operating.
5. Remove as much soil as possible from dishes before loading into racks.
6. Do not overfill racks.
7. Ensure that glasses are placed upside down in the rack.
8. Ensure that all chemicals being injected into machine have been verified as being at the correct concentrations.
9. Clean out the machine at the end of every workday as per the instructions in the manual.
10. Always contact a **QUALIFIED SERVICE AGENCY** whenever a serious problem arises.
11. Follow all safety procedures, whether listed in this manual or put forth by local, state or national codes/regulations.

<b>PROBLEM</b>	<b>POSSIBLE CAUSE</b>	<b>REMEDY</b>
Dishmachine will not run, no voltage at wash relay terminals L1 and T1.	<ol style="list-style-type: none"> <li>1. Service disconnect switch off or faulty.</li> <li>2. Branch circuit breaker tripped/fuse blown.</li> <li>3. Loose or broken connection to dishmachine.</li> </ol>	<ol style="list-style-type: none"> <li>1. Turn disconnect on.</li> <li>2. Reset or replace.</li> <li>3. Tighten or replace connections.</li> </ol>
Machine will not run in "ON" position or in Delime mode.	<ol style="list-style-type: none"> <li>1. Door switch is defective.</li> <li>2. Faulty OFF/ON/FILL switch.</li> <li>3. Faulty NORMAL/DELIME switch.</li> </ol>	<ol style="list-style-type: none"> <li>1. With door open, check for voltage between ORANGE/WHITE door switch and neutral. If 120V, replace the door switch.</li> <li>2. With switch ON, check voltage between BLACK and WHITE/BLACK ON switch. Replace the switch if 120V.</li> <li>3. In the NORMAL position, check the voltage between WHITE/BLACK and WHITE/RED wires to switch. If 120V, replace the switch.</li> </ol>
Machine fills continuously even with no power applied to the machine.	Water inlet solenoid valve allowing water into machine.	<ol style="list-style-type: none"> <li>1. Check water pressure during fill, pressure must be 15 psi.</li> <li>2. Repair or replace water inlet solenoid valve. (See instructions on servicing solenoid valve, pg. 17.)</li> </ol>
Dishmachine runs continuously in the wash cycle.	<ol style="list-style-type: none"> <li>1. Machine is in Delime mode.</li> <li>2. Possible issue with CAM timer.</li> </ol>	<ol style="list-style-type: none"> <li>1. Flip NORMAL/DELIME switch to NORMAL mode.</li> <li>2. Contact Jackson Technical Service.</li> </ol>
Dishmachine will not hold water.	<ol style="list-style-type: none"> <li>1. Faulty drain ball.</li> <li>2. Obstructed drain hole.</li> <li>3. Drain linkage is binding.</li> </ol>	<ol style="list-style-type: none"> <li>1. Replace drain ball.</li> <li>2. Clear obstruction from drain.</li> <li>3. Repair damaged drain mechanism parts.</li> </ol>
Dishmachine will not fill, other functions work.	<ol style="list-style-type: none"> <li>1. Y-strainer clogged.</li> <li>2. Incoming water to unit is turned off.</li> <li>3. Faulty OFF/ON/FILL switch.</li> <li>4. Faulty solenoid coil.</li> </ol>	<ol style="list-style-type: none"> <li>1. Clean strainer screen.</li> <li>2. Turn on water to the machine.</li> <li>3. Depress switch, measure between BLACK and WHITE/GREEN wire. If 120V, replace switch.</li> <li>4. If coil has voltage but no continuity, replace solenoid.</li> </ol>

# MAINTENANCE

---

## TROUBLESHOOTING

PROBLEM	POSSIBLE CAUSE	REMEDY
Dishmachine fills slowly and/or the rinse is weak.	<ol style="list-style-type: none"> <li>1. Clogged or obstructed rinse arms.</li> <li>2. Low incoming water pressure.</li> <li>3. Y-strainer is clogged.</li> </ol>	<ol style="list-style-type: none"> <li>1. Remove and clean the rinse arms.</li> <li>2. Adjust the water pressure regulator to ensure that there is 15 psi water flow pressure.</li> <li>3. Clean out the Y-strainer.</li> </ol>
Doors will not close completely.	<ol style="list-style-type: none"> <li>1. Improper spring tension.</li> <li>2. Obstruction in door channel.</li> </ol>	<ol style="list-style-type: none"> <li>1. Adjust spring tension as required by loosening (not removing) spring bolt nuts and adjusting the tension. Tighten nuts when done.</li> <li>2. Remove the obstruction.</li> </ol>
Water leaks at wash pump.	<ol style="list-style-type: none"> <li>1. Wash pump seal is defective.</li> <li>2. Petcock or pump drain leaking.</li> </ol>	<ol style="list-style-type: none"> <li>1. Replace wash pump seal.</li> <li>2. Close shut or tighten.</li> </ol>
Dishes are not coming clean.	<ol style="list-style-type: none"> <li>1. Machine temperatures are not up to the minimum requirements.</li> <li>2. No detergent/too much detergent.</li> </ol>	<ol style="list-style-type: none"> <li>1. Verify that incoming water temperature meets requirements listed on the machine data plate.</li> <li>2. Adjust detergent concentration as required for the amount of water held by the machine. (It is recommended the chemical provider be contacted before making any changes.)</li> </ol>

# PARTS

## CONTROL BOX COMPONENTS

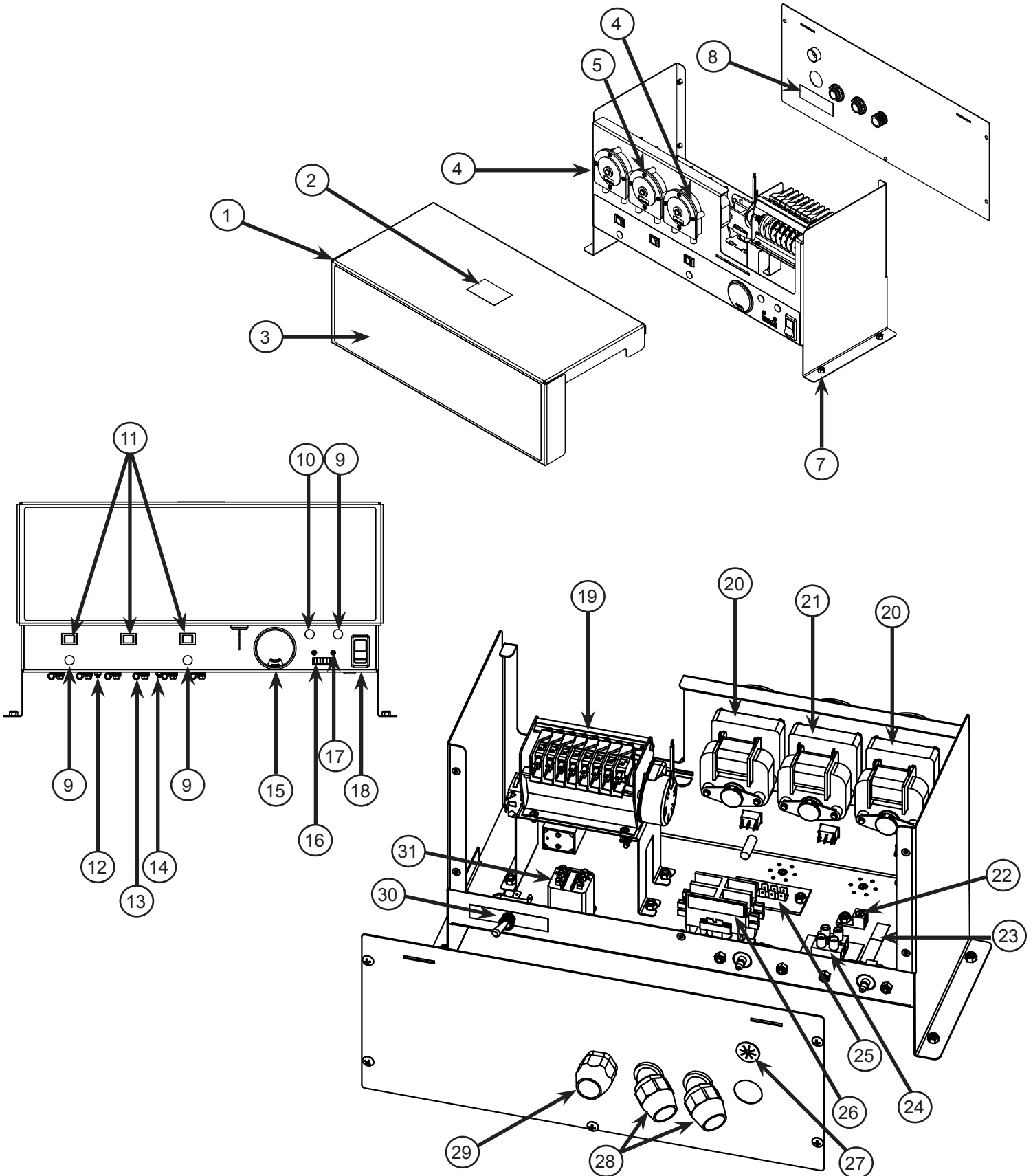

**PARTS****CONTROL BOX COMPONENTS**

<b>ITEM</b>	<b>QTY</b>	<b>DESCRIPTION</b>	<b>PART NUMBER</b>
1	1	Control Box Assembly	05700-003-81-49
2	1	Decal, Warning–Disconnect Power	09905-100-75-93
3	1	Upper Decal, Cons XL-E	09905-004-00-07
4	2	Peri Pump, 36 RPM	05700-003-25-02
5	1	Peri Pump, 14 RPM	05700-003-25-03
7	18	Lock Nut, 10-24 S/S Hex w/Nylon Insert	05310-373-01-00
8	1	Decal, Copper Conductors	09905-011-47-35
9	3	Light, Red	05945-504-07-18
10	1	Light, Green	05954-504-08-18
11	3	Switch, Prime	05930-011-49-54
12	6	Screw, 6-32 x 3/8 w/Washer	05305-002-25-91
13	6	P Clamp	05975-002-61-42
14	11	Lock Nut, 6-32 Hex w/Nylon Insert	05310-373-03-00
15	1	Gauge, Thermometer	06685-111-68-49
16	1	Cycle Counter, 115V	05990-111-35-38
17	2	Screw, 4-40 x 1/4 Phillips Pan Head w/Washer	05305-002-32-38
18	1	Switch, Power	05930-111-38-79
19	1	Timer, Cons XL-E 90S 115V	05945-004-11-78
20	2	Chemical Feeder Pump Kit Assembly, 36 RPM w/Motor	05700-003-25-02
21	1	Chemical Feeder Pump Kit Assembly, 14 RPM w/Motor	05700-003-25-03
22	1	Lug, Ground	05940-200-76-00
23	1	Decal, Power Connection	09905-011-47-64
24	1	Terminal Block	05940-500-09-61
25	1	Terminal Board	05940-021-94-85
26	1	Contact, 115V, 30A	05945-109-05-69
27	1	Bushing, Heyco Split	05975-200-40-00
28	2	Fitting, 1/2", 45 degree, Plastic	05975-011-45-23
29	1	Fitting, 1/2", Plastic	05975-011-45-13
30	1	Relay, Pole	05945-111-35-19
31	1	Switch, Delime	05930-301-21-18
	1	Lock, Control Box (NOT SHOWN)	05340-102-01-00

**CHEMICAL FEEDER PUMP COMPONENTS**

Chemical Feeder Pump Kit Assembly, 36 RPM  
w/Motor 120V (Complete) 05700-003-25-02

Chemical Feeder Pump Kit Assembly, 14 RPM  
w/Motor 120V (Complete) 05700-003-25-03

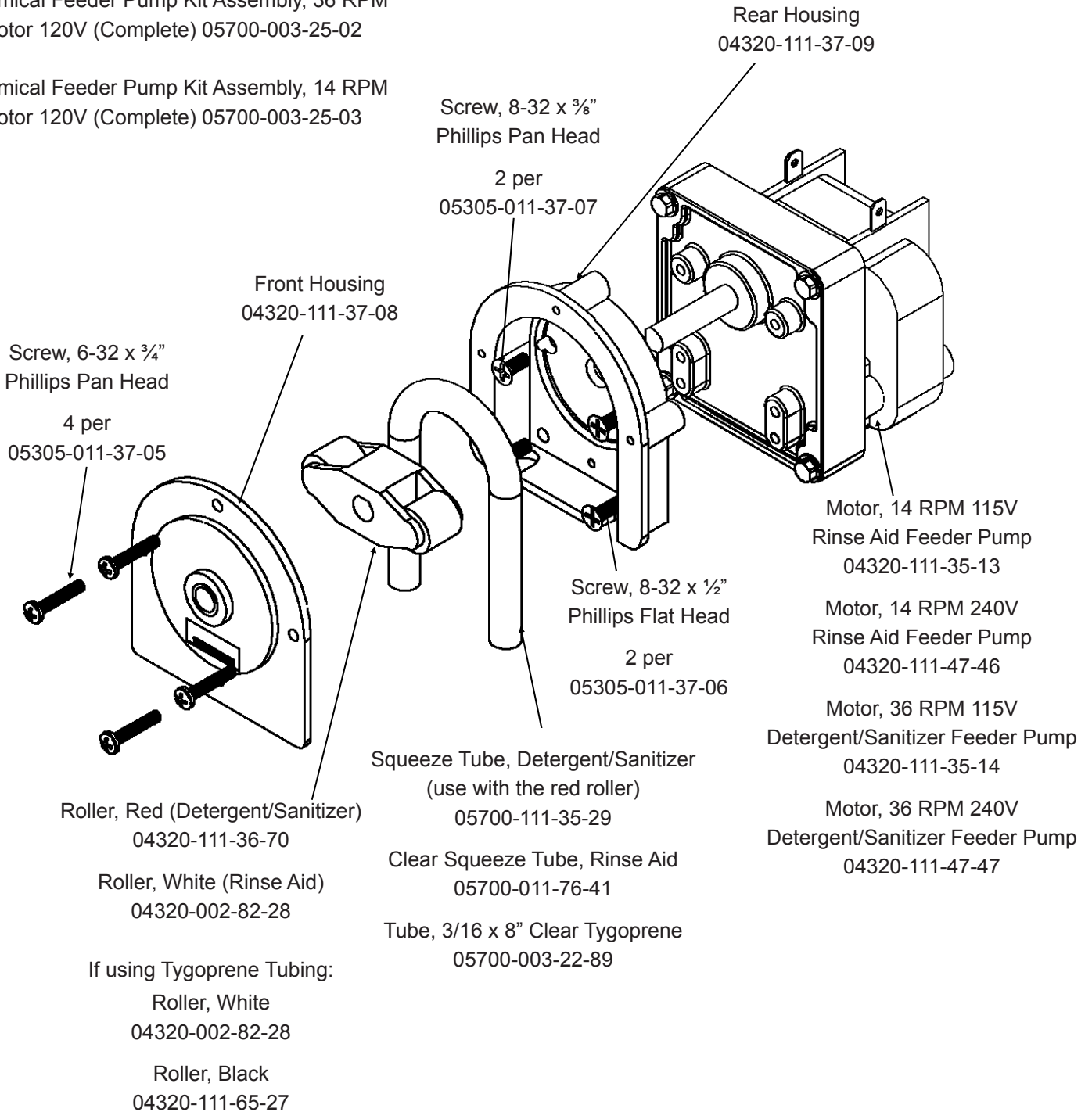

# PARTS

## HOOD ASSEMBLY

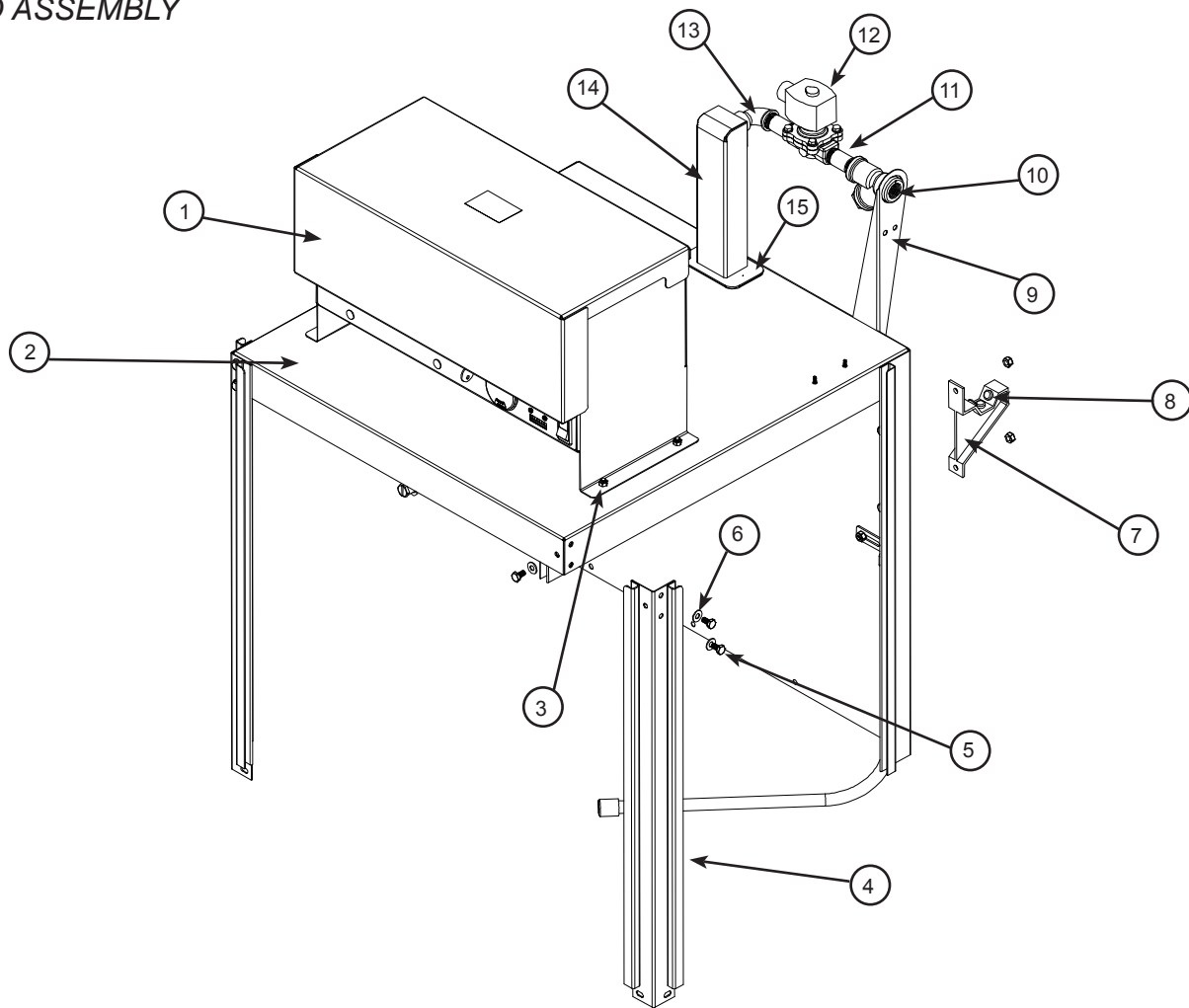

ITEM	QTY	DESCRIPTION	PART NUMBER
1	1	Control Box Assembly	05700-004-01-65
2	1	Hood, Weldment	05700-003-22-05
3	10	Lock Nut, 1/4-20" w/Nylon Insert	05310-374-01-00
4	2	Hood Support	05700c-002-78-99
5	6	Bolt, 1/4-20 x 1/2"	05305-274-02-00
6	12	Washer, S/S 1/4"	05311-174-01-00
7	2	Bracket, Cantilever Support	09515-003-15-64
8	6	Wear Button	05700-011-88-01
9	1	Bracket, Plumbing Support	05700-003-24-25
10	1	Strainer, Inlet 1/2"	04730-217-01-10
11	2	Nipple, 1/2" x 2" (Brass)	04730-207-19-00
12	1	Solenoid Valve, 1/2", 120V	04810-003-71-55
13	1	Elbow, 1/2" Street (Brass)	04730-206-08-00
14	1	Air Gap Weldment	05700-002-81-70
15	1	Gasket, Air Gap	05330-002-14-48

**PARTS**  
*DOOR ASSEMBLY*

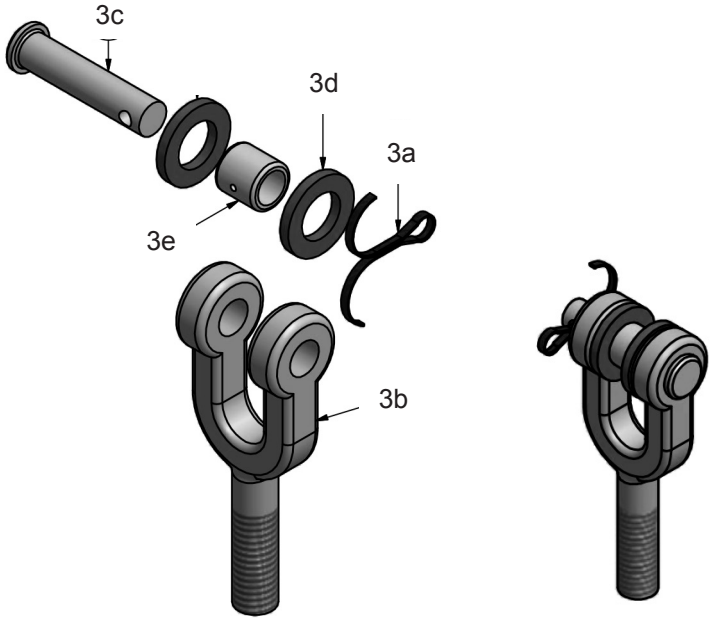
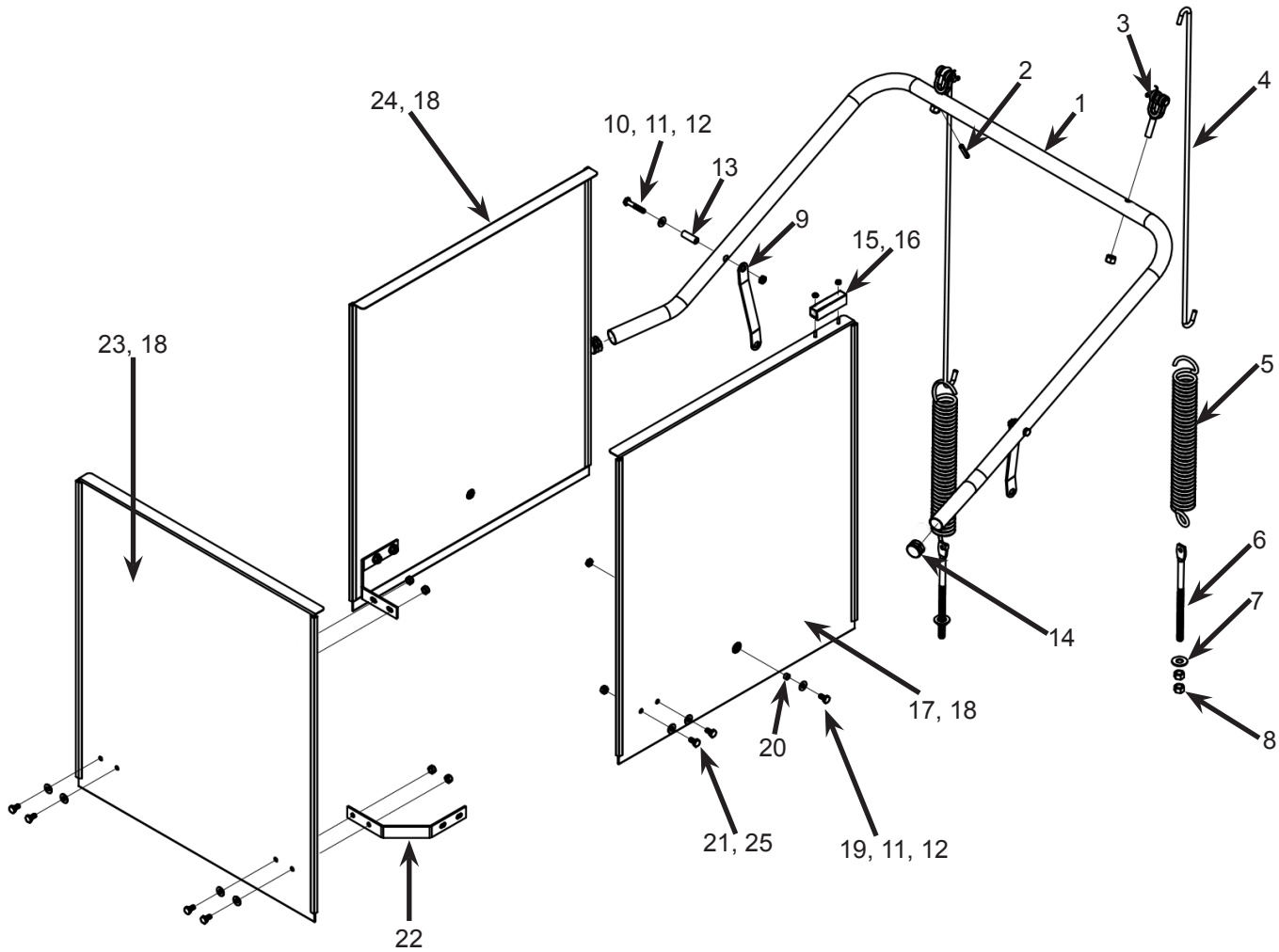

**PARTS****DOOR ASSEMBLY**

<b>ITEM</b>	<b>QTY</b>	<b>DESCRIPTION</b>	<b>PART NUMBER</b>
1	1	Arm, Cantilever	05700-003-52-91
2	2	Spring Pin, 1/4" Dia. x 1-1/8"	05315-407-06-00
3	2	Yoke Assembly	05700-000-75-77
3a	1	Cotter Pin	05315-207-01-00
3b	1	Yoke	05700-000-75-78
3c	1	Clevis Pin	05315-700-01-00
3d	2	Nylon Washer	05311-369-03-00
3e	1	Bushing	03120-100-03-00
3f	2	Lock Nut, 3/8"-16 S/S (not shown)	05310-256-04-00
4	2	Rod, Spring Universal	05700-003-67-39
5	2	Spring, Cantilever	05340-109-02-00
6	2	Bolt, Hanger Eye 3/8"-16"	05306-956-05-00
7	2	Washer, 3/8" I.D. x 7/8" O.D.	05311-176-02-00
8	4	Nut, Hex 3/8"-16" S/S	05310-276-01-00
9	2	Cantilever Arm Connector	05700-011-90-99
10	2	Screw, 1/4"-20"	05305-274-23-00
11	2	Washer, 1/4" I.D. S/S	05311-174-01-00
12	2	Lock Nut, 1/4"-20" S/S w/Nylon Insert	05310-374-02-00
13	2	Sleeve, Cantilever Arm	05700-000-85-69
14	2	Plug, Cantilever	05340-011-35-00
15	1	Door Magnet	05930-111-51-68
16	2	Lock Nut, 8-32 S/S w/Nylon Insert	05310-272-02-00
17	1	Door Assembly, Right Side	05700-002-30-88
18	6	Door Guides	05700-111-33-59
19	10	Bolt, 1/4"-20" x 1/2" S/S	05305-274-02-00
20	2	Spacer, PB Bolt	05700-000-29-40
21	8	Lock Nut, 1/4"-20" w/Nylon Insert	05310-374-01-00
22	2	Bracket, Door Connecting	05700-021-33-39
23	1	Front Door Assembly	05700-002-30-89
24	1	Door Assembly, Left Side	05700-002-30-87

Wash Arm Assembly  
05700-021-87-76

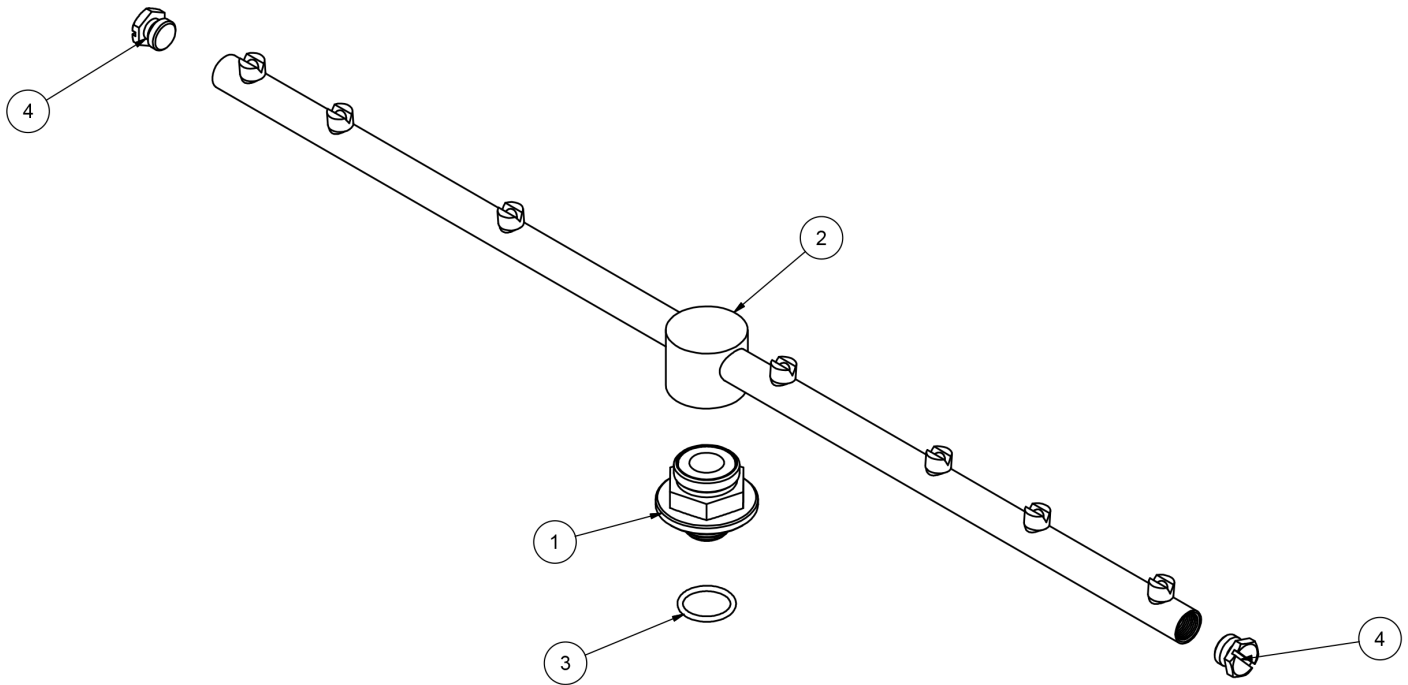

ITEM	QTY	DESCRIPTION	PART NUMBER
1	2	Bearing	05700-021-35-97
2	1	Wash Arm	05700-021-63-42
	1	Wash Arm w/End Caps	05700-003-57-70
3	1	O-Ring. 117-S70 Silicon	05330-002-60-69
4	2	Wash Arm End Caps	05700-011-35-92

# PARTS

## WASH MANIFOLD ASSEMBLY

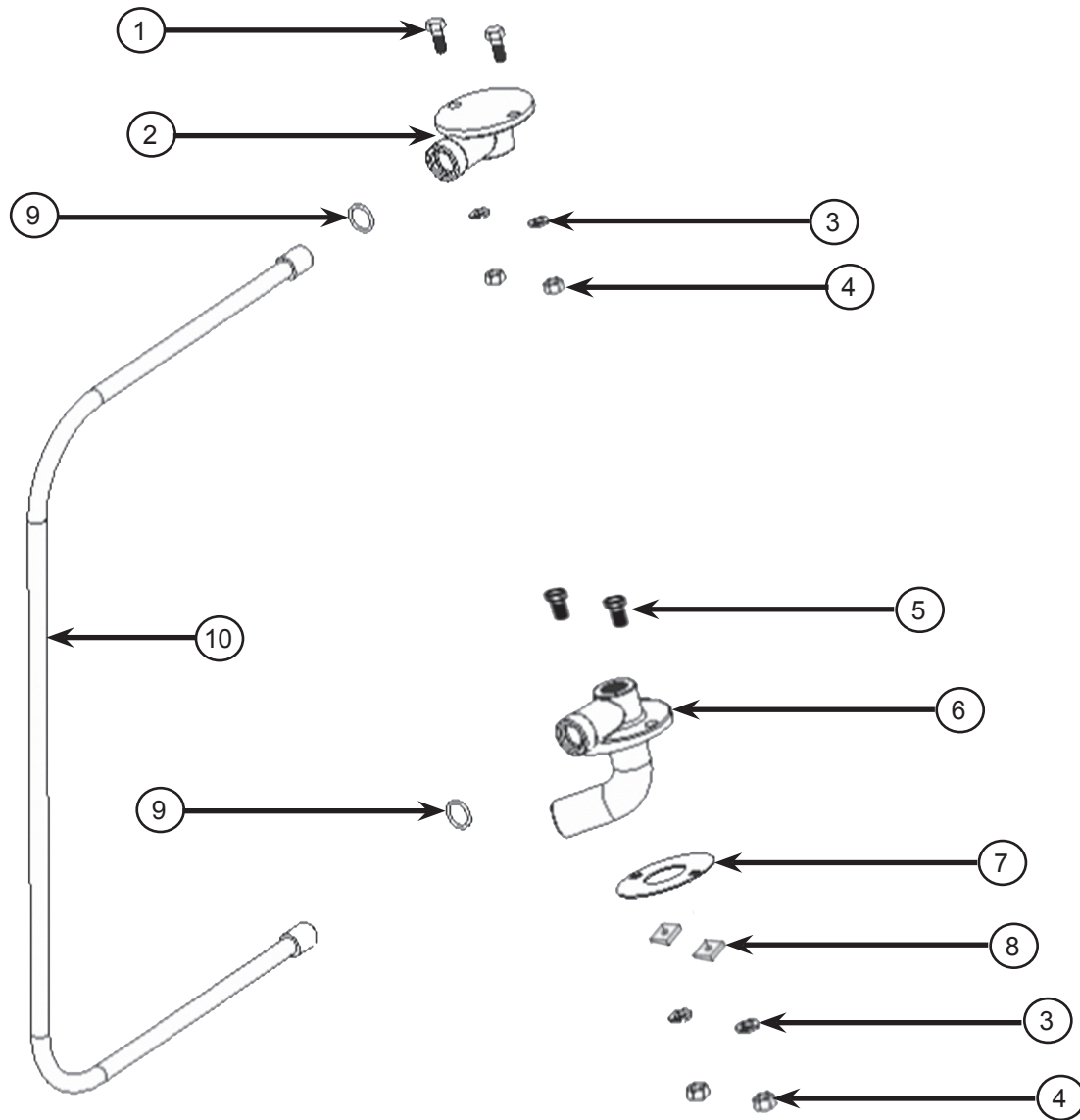

ITEM	QTY	DESCRIPTION	PART NUMBER
1	2	Bolt, 3/8"-16 x 7/8" S/S	05306-011-36-95
2	1	Casting, Upper Wash Manifold	05700-031-34-82
3	4	3/8" Lockwasher, S/S	05311-276-01-00
4	4	3/8" Hex Nut, S/S	05310-276-01-00
5	2	Bolt, 3/8"-16 x 1-1/4" S/S	05305-276-10-00
6	1	Lower Wash Manifold	05700-003-78-40
7	1	Gasket, Wash Manifold	05700-111-35-03
8	2	3/8" Bevel, Square	05311-011-35-03
9	2	O-Ring	05330-111-35-15
10	1	Wash Manifold Tube	05700-003-58-89

**PARTS**  
TUB ASSEMBLY

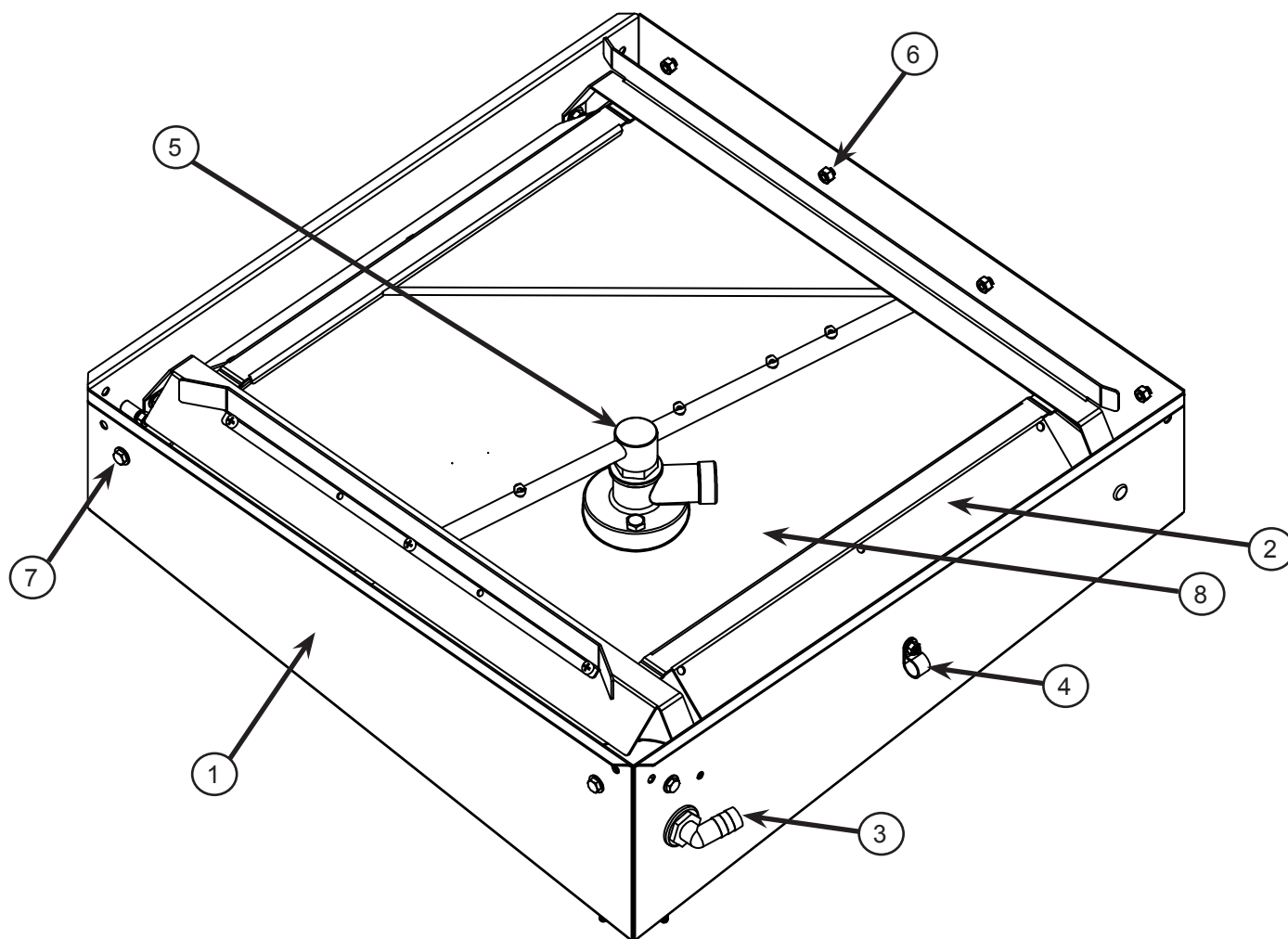

ITEM	QTY	DESCRIPTION	PART NUMBER
1	1	Tub Assembly	05700-003-78-35
2	1	Rack Guide Assembly	05700-031-36-76
3	1	Bulkhead Fitting, 1/2"	04730-011-45-21
4	1	Clamp, Nylon	04730-011-39-01
	1	Lock Nut, 10-24 S/S	05310-373-01-00
5	1	Wash Arm Assembly	05700-021-87-76
6	4	Bolt, 1/4-20 x 1/2" S/S	05305-274-02-00
	4	Lock Nut, 1/4-20 S/S	05310-374-01-00
7	4	Bolt, 1/4-20 x 1-1/8" S/S	05305-274-21-00
	4	Lock Nut, 1/4-20 S/S	05310-374-01-00
8	1	Lower Wash Manifold	05700-003-78-40

# PARTS

## WASH SUMP ASSEMBLY

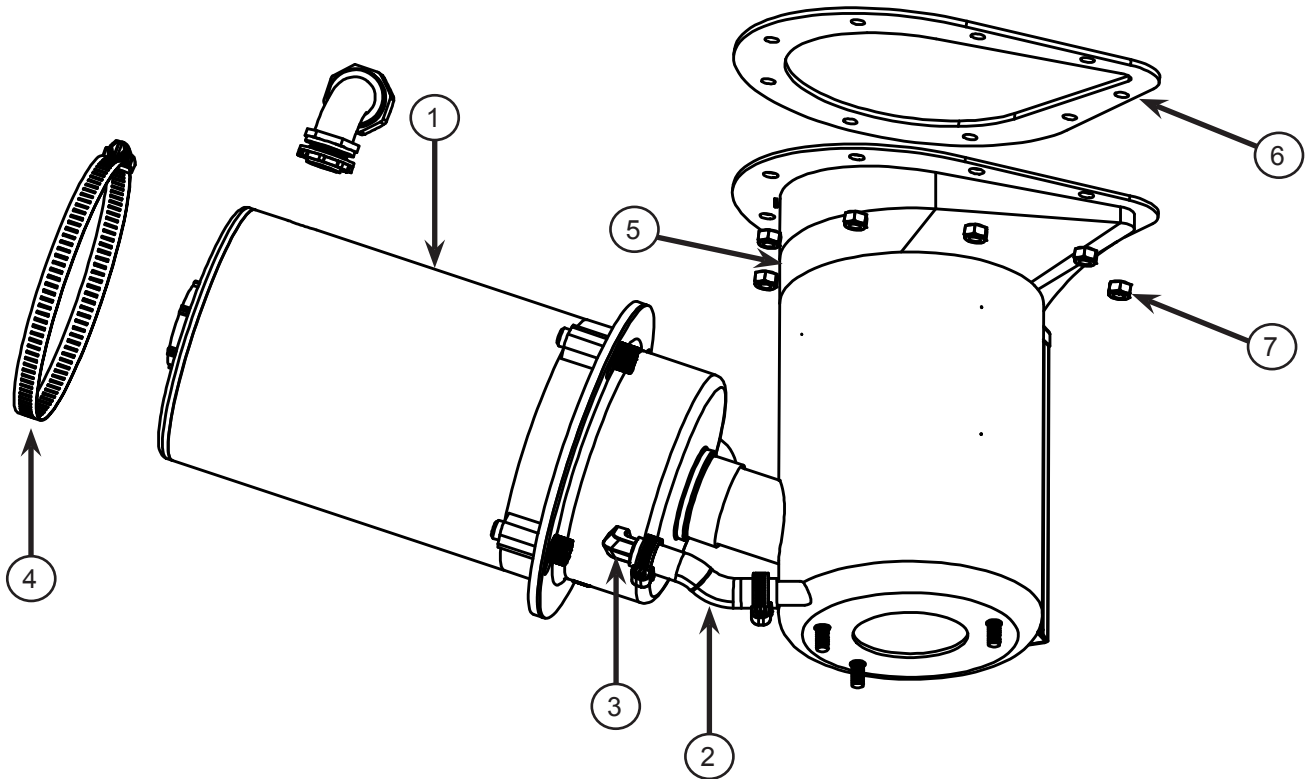

ITEM	QTY	DESCRIPTION	PART NUMBER
1	1	Pump and Motor Assembly (see page 29)	06105-002-69-78
2	1	Pump Drain Hose	05700-003-78-58
3	2	Clamp, 7/16" to 25/32"	04730-011-36-05
4	1	Clamp, 5-5/8" to 6", #96	04730-011-34-90
5	1	Sump Weldment	05700-003-78-41
6	1	Sump Gasket	05330-003-78-31
7	9	Lock Nut, 1/4-20 S/S	05310-374-01-00
	1	Drain Solenoid, 115V (NOT SHOWN)	04810-200-11-00
	1	Drain Link Connector (NOT SHOWN)	05700-002-38-10

---

**PARTS**  
*SPILLWAY ASSEMBLY*

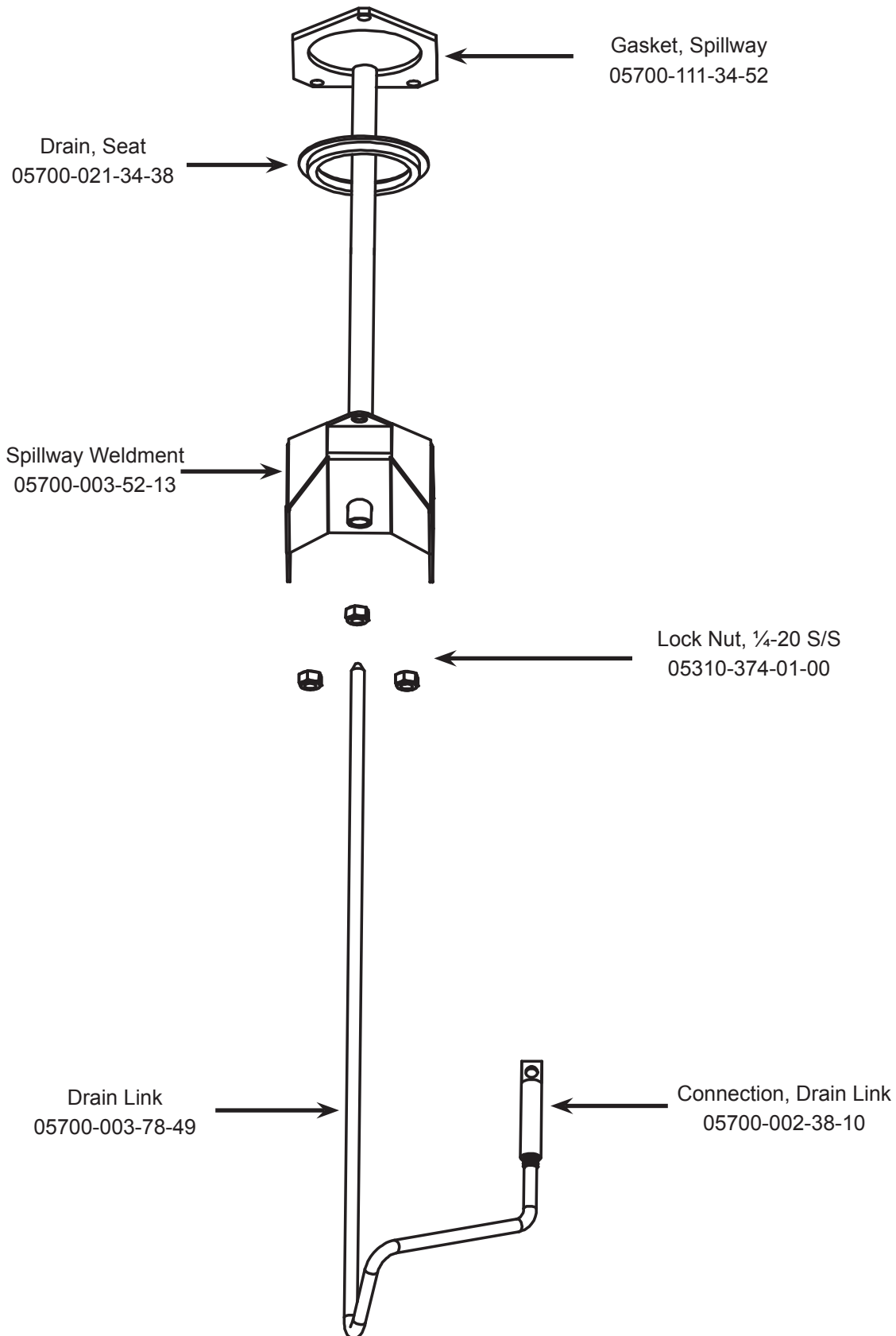

# PARTS

## PUMP & MOTOR ASSEMBLY

Complete Pump and Motor Assembly  
06105-002-69-78

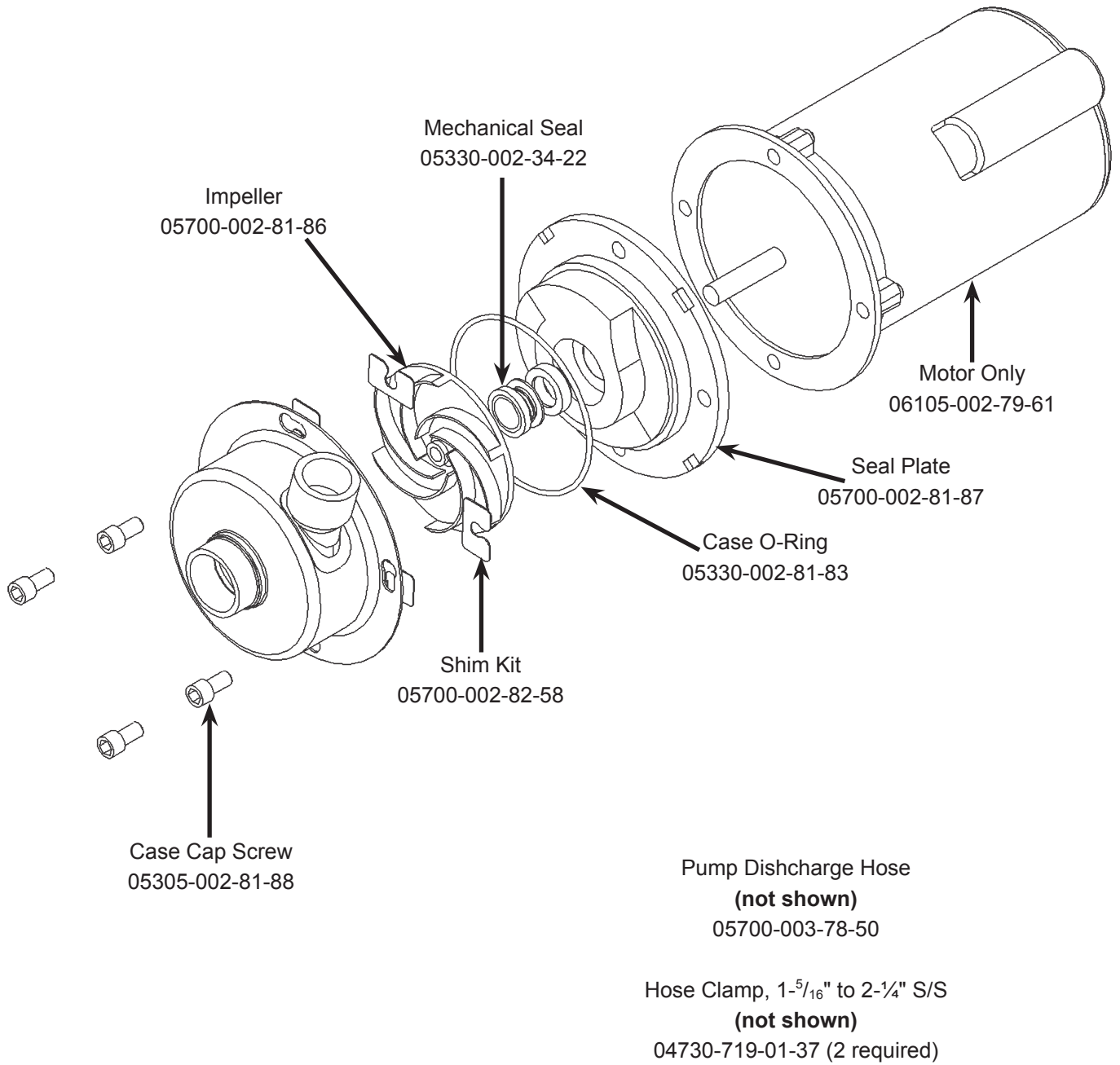

**PARTS**  
**FRAME ASSEMBLY**

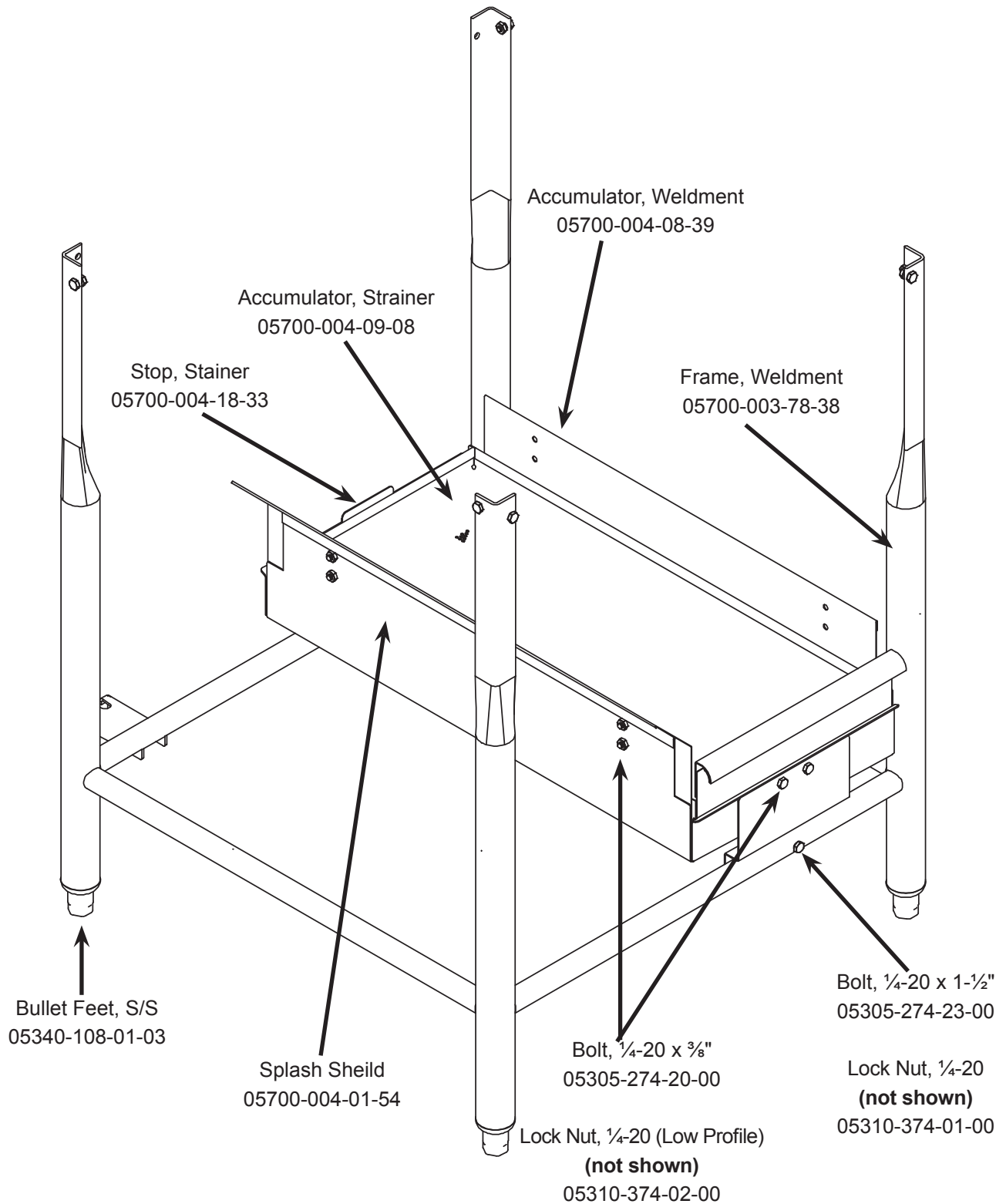

# PARTS

## MISCELLANEOUS

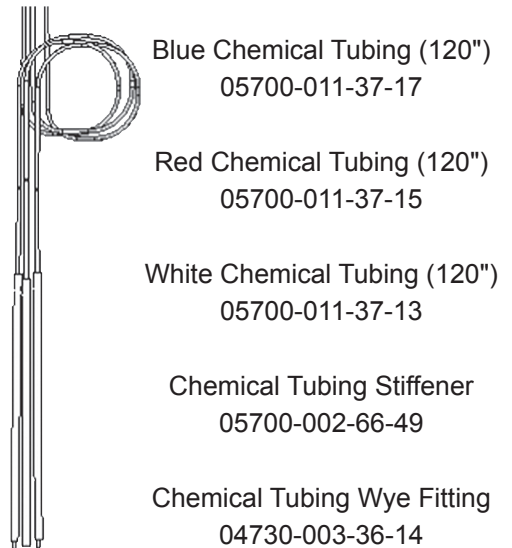
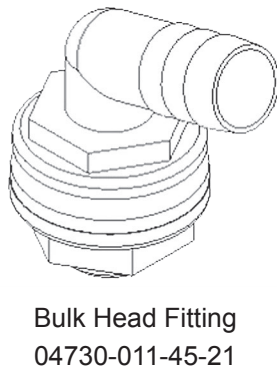
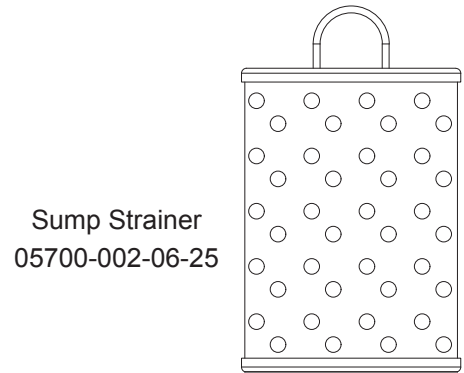
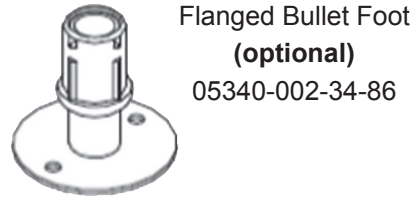
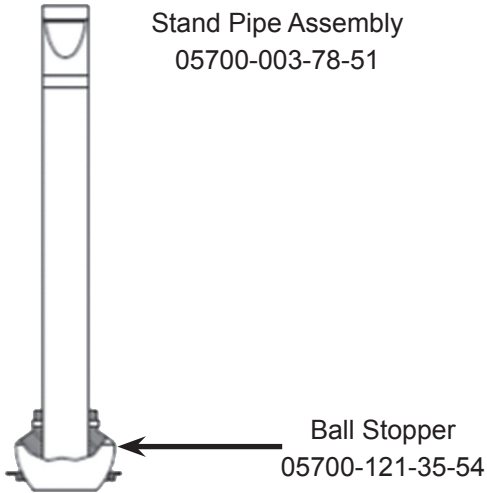

Water Hammer Arrestor Kit

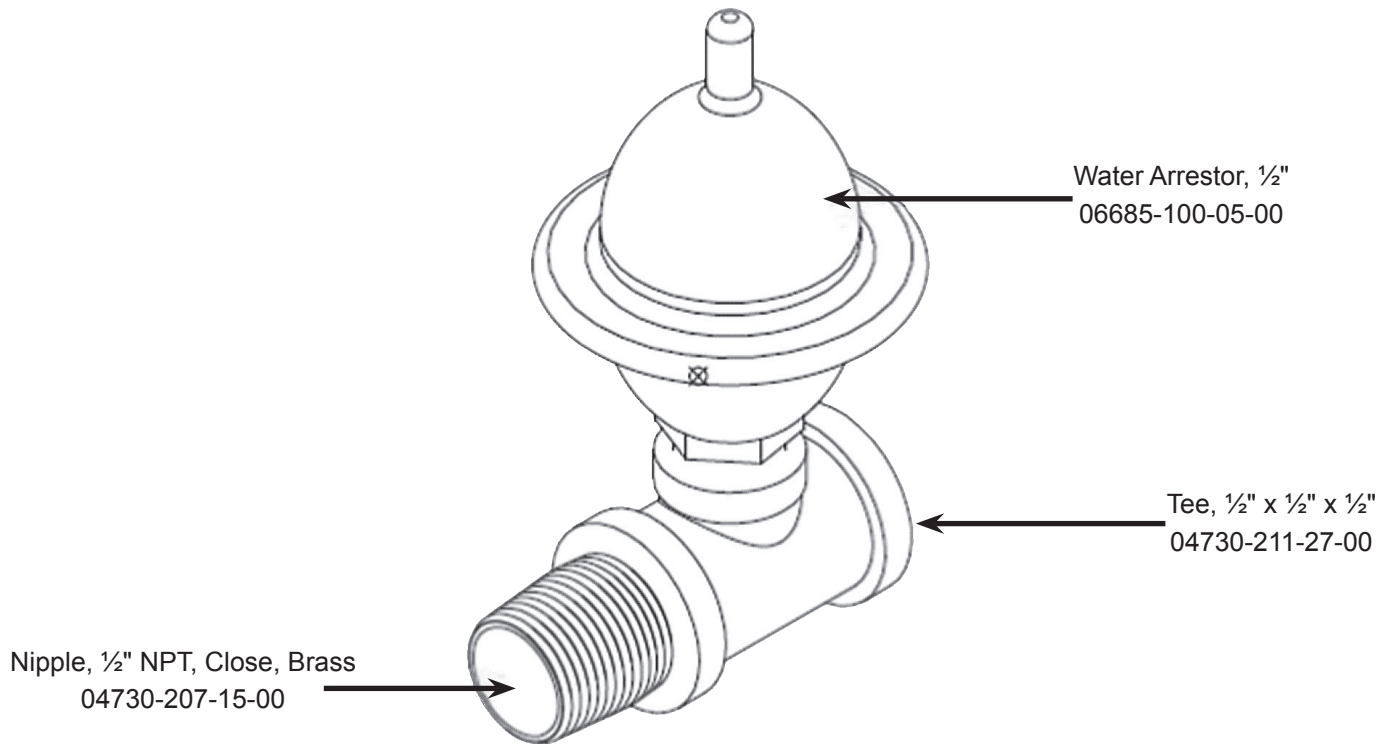



*ELECTRICAL DIAGRAM, CONSERVER XL-E, 208 VOLTS, 50/60 HZ, SINGLE PHASE*

