

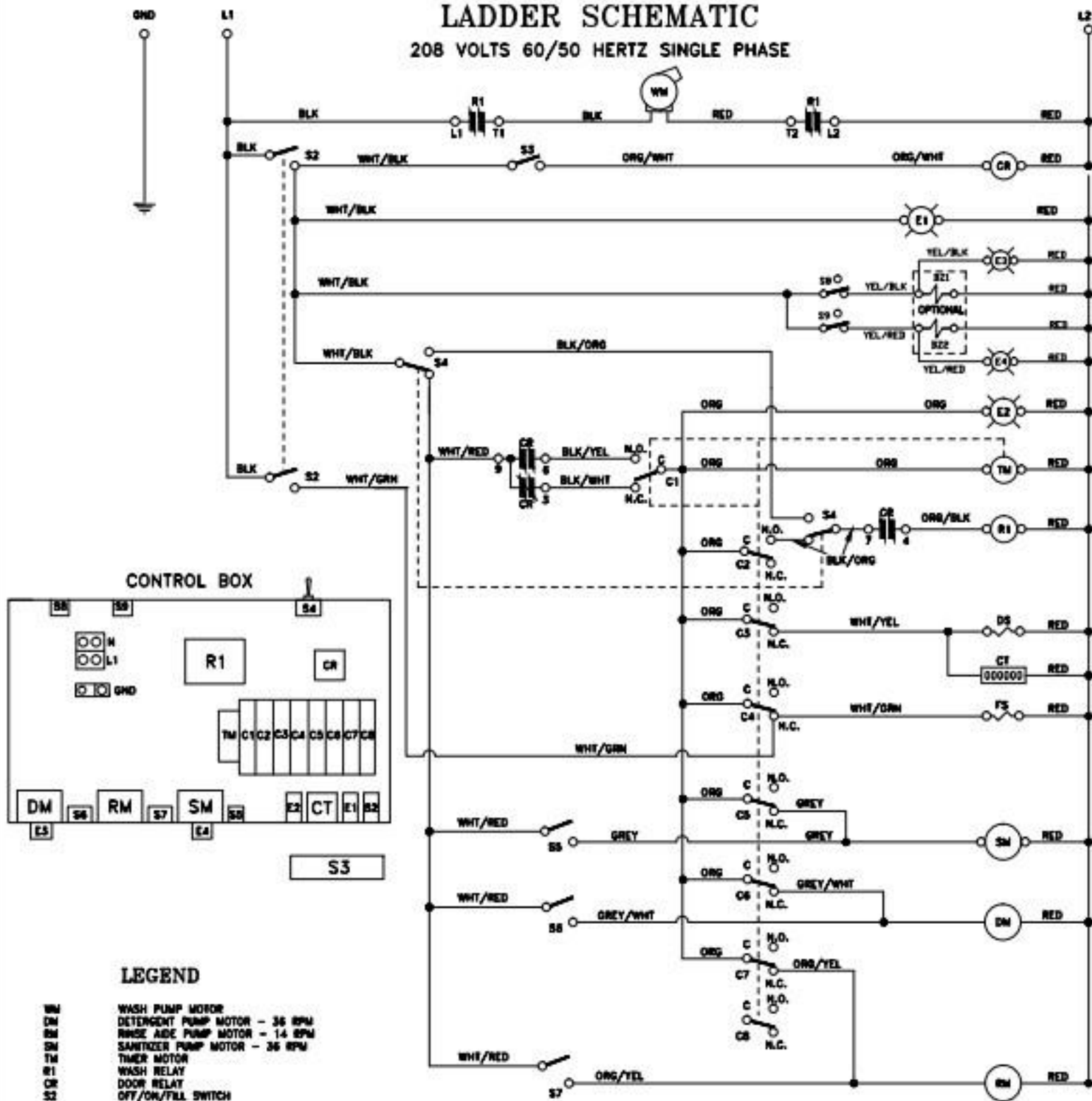

# CONSERVER XL-E ELECTRICAL DIAGRAM

## LADDER SCHEMATIC

208 VOLTS 60/50 HERTZ SINGLE PHASE



### CONTROL BOX

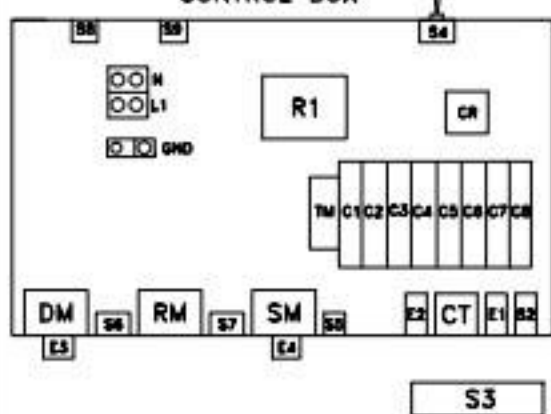

### LEGEND

- WM WASH PUMP MOTOR
- DM DETERGENT PUMP MOTOR - 36 RPM
- RM RINSE AID PUMP MOTOR - 14 RPM
- SM SANITIZER PUMP MOTOR - 36 RPM
- TM TIMER MOTOR
- R1 WASH RELAY
- CR DOOR RELAY
- S2 OFF/ON/FILL SWITCH
- S3 DOOR SWITCH
- S4 DELINE SWITCH
- S5 SANITIZER PRIME SWITCH
- S6 DETERGENT PRIME SWITCH
- S7 RINSE AID PRIME SWITCH
- S8 DETERGENT VACUUM SWITCH
- E1 POWER LIGHT
- E2 CYCLE LIGHT
- E3 DETERGENT LIGHT
- E4 SANITIZER LIGHT
- DS DRAIN SOLENOID
- FS FILL SOLENOID
- C1 CYCLE/RESET MICROSWITCH
- C2 WASH MICROSWITCH
- C3 DRAIN MICROSWITCH
- C4 FILL MICROSWITCH
- C5 SANITIZER MICROSWITCH
- C6 DETERGENT MICROSWITCH
- C7 RINSE ADDITIVE MICROSWITCH
- C8 SPARE MICROSWITCH
- CT COUNTER
- BZ1 DETERGENT BUZZER
- BZ2 SANITIZER BUZZER

### TIMING CHART

