NO. 71151

ISSUED: SEPT. 8, 1999

REVISED: SEPT. 25, 2001



**HOSHIZAKI
MODULAR CRESCENT CUBER**

MODELS

KM-280MAF

KM-280MWF

KM-280MAH

KM-280MWH

PARTS LIST

HA

KM-280MAF	J-0	Dec., 1998
	J-1	June 1999
	J-2	Sept., 1999
	K-0	Dec., 1999
	L-0	Jan., 2001

KM-280MWF	J-0	Dec., 1998
	J-1	June 1999
	J-2	Sept., 1999
	K-0	Dec., 1999
	L-0	Jan., 2001

KM-280MAH	L-0	April 2001
------------------	-----	------------

KM-280MWH	L-0	May 2001
------------------	-----	----------

MATERIAL ABBREVIATIONS

ALUMINUM

AL = Aluminum

COPPER

CU = Copper

PLASTIC

ABS = Acrylonitrile -butadiene - styrene
 AC = Polyacetal
 EVA = Ethylene vinyl acetate
 PA = Polyamide = Nylon
 PC = Polycarbonate
 PE = Polyethylene
 PES = Polyester
 PETP = Polyethylene terephthalate = Tetlon
 PP = Polypropylene
 PS = Polystyrene
 PTFE = Polytetrafluoroethylene = Teflon
 PUR = Polyurethane
 PVC = Polyvinyl chloride

RUBBER

VN = Vinyl Nitrile
 EPDM = EP rubber
 NBR = Nitrile butadiene rubber
 NR = Natural rubber
 NP = Neoprene
 SIR = Silicone rubber
 SYR = Synthetic rubber
 EPH = Epichlorohydrin

STEEL

GS = Galvanized steel
 SS = Stainless steel
 PS = Plated steel
 PAS = Primed steel

AUXILIARY CODE

Ex.1

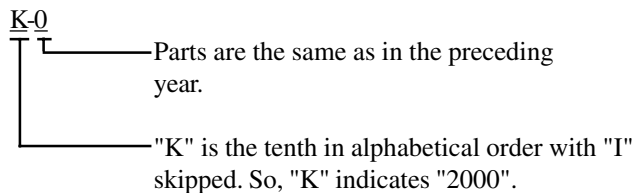

(Note) - = Part deleted.

x = Part deleted and replaced by "o" part.

Ex.2

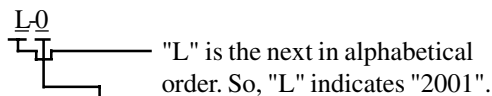

o = New part for "x" in the same auxiliary code.

Ex.3

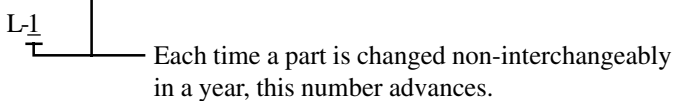

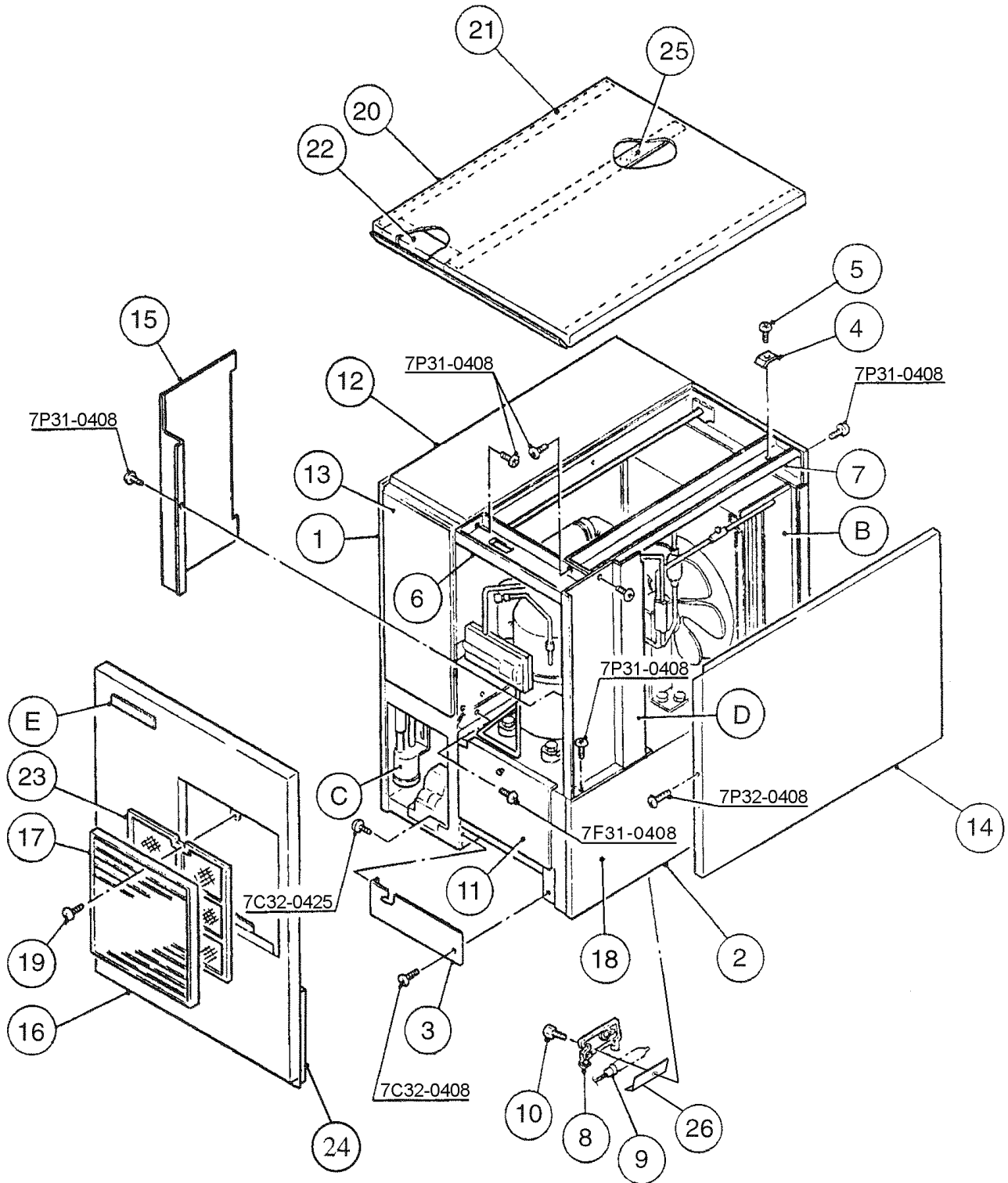

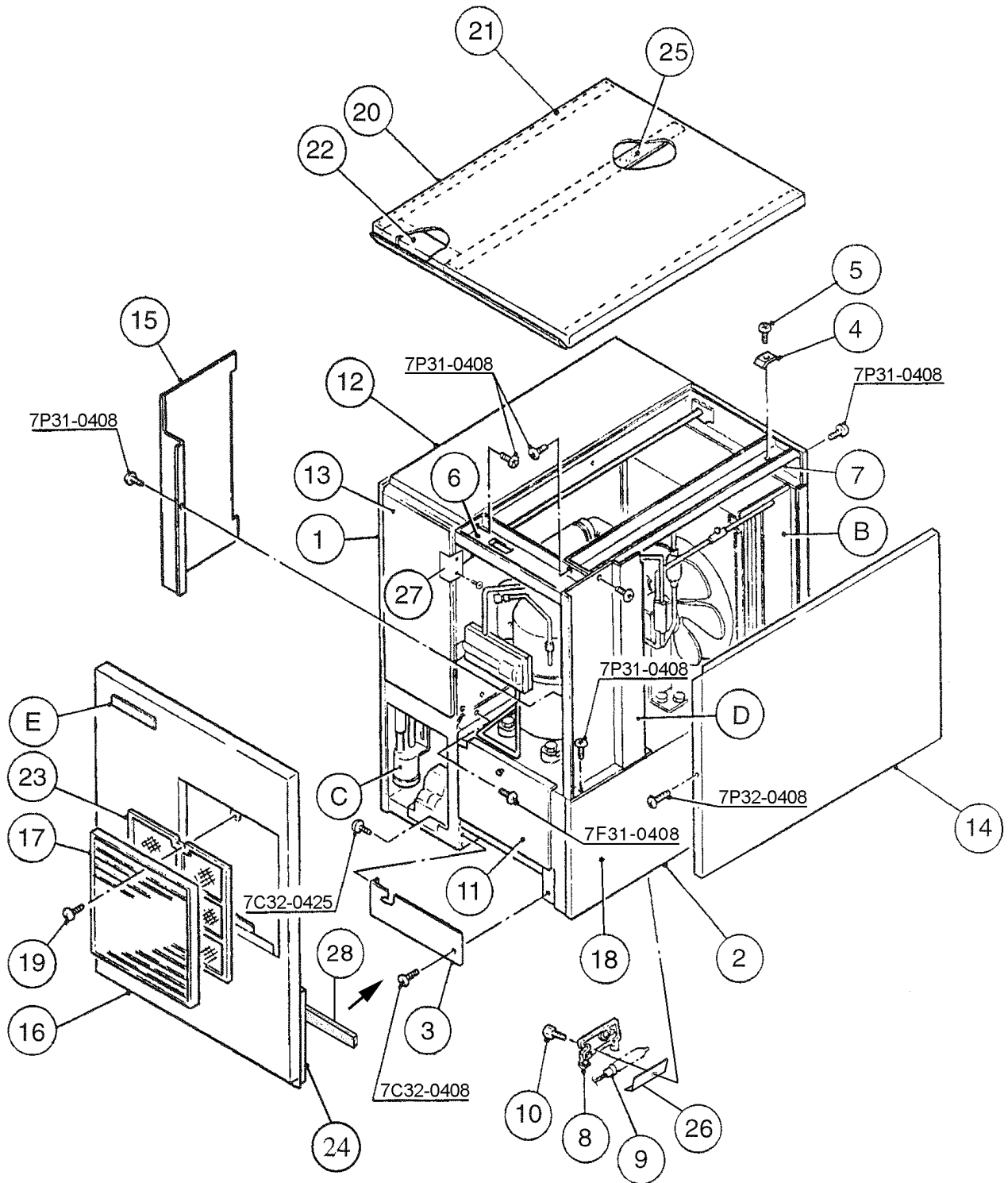

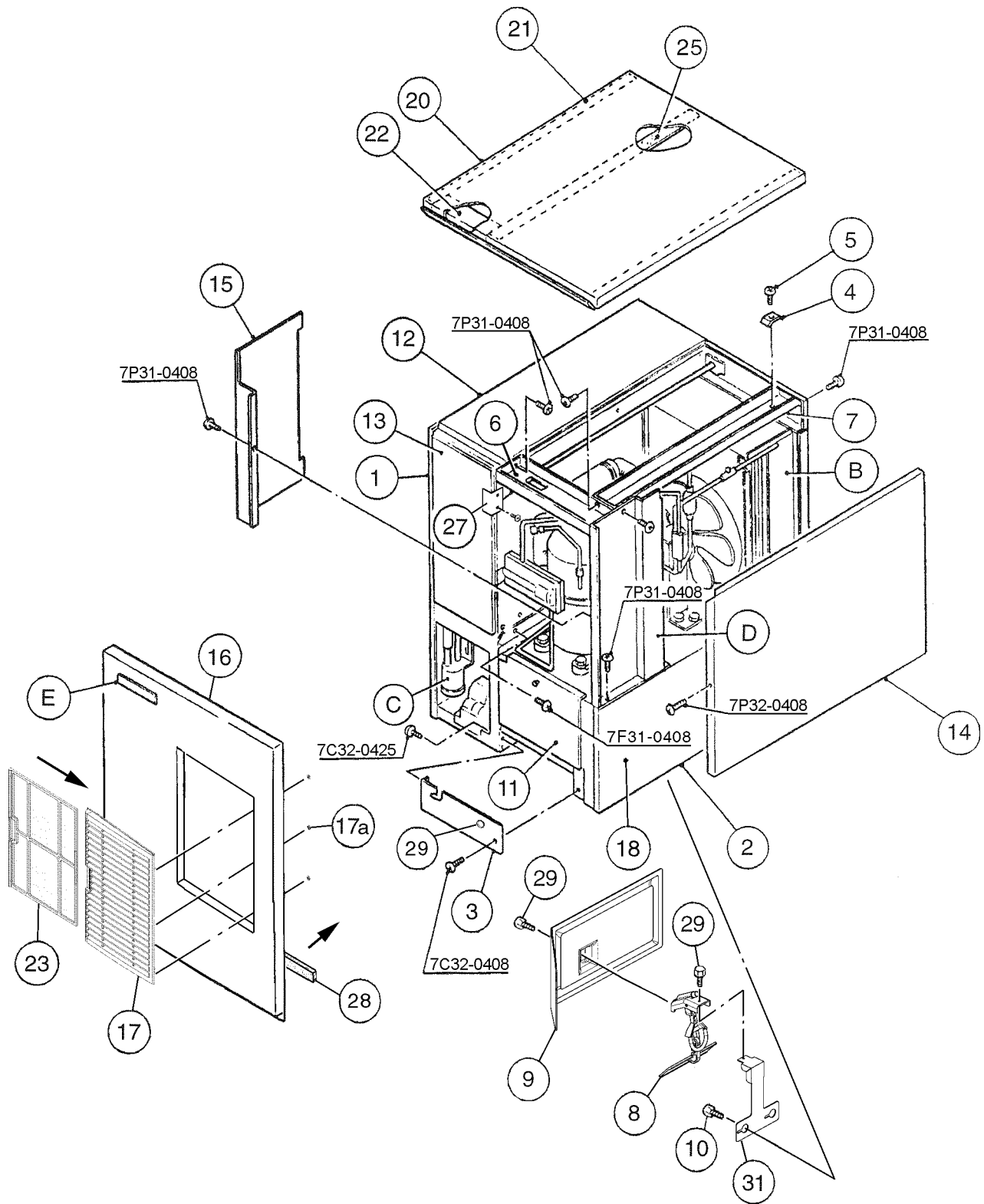

HA

MODEL: KM-280MAF, MAH TITLE: A. ICE CUBER ASSEMBLY										
INDEX NO.	DESCRIPTION	MATERIAL OR MODEL NUMBER	PART NUMBER	REQUIRED NUMBER						
				KM-280MAF			KM-280MAH			
				J-0 J-1	J-2	K-0	L-0	L-0		
B	REFRIGERATION CIRCUIT	-	1A0392A01	1	1	1	1	1		
C	WATER CIRCUIT	HS-1207	1A0283A04	1	1	1	1	1		
D	CONTROL BOX ASSEMBLY	-	2A1423A01	1	1	x1				
		-	2A1960A01			o1	1	-		
		-	2a2247A01					1		
	T2 SCREW	4X8	7P31-0408	4	4	4	4	4		
E	LABEL LOCATION	-	3A1223A01	1	1	1	1	-		
		-	3A1903A01					1		
1	EVAP. CASE	HS-1010	1A0277G01	1	1	1	x1			
		-	1A0532G01				o1	-		
		-	1A0579G01					1		
2	BASE	-	2A1321G04	1	1	1	1	-		
		-	2A2146G04					1		
	FT SCREW	4X8	7F31-0408	7	7	7	7	7		
3	FRAME	ABS	3A0217G01	1	1	1	1	1		
	TRUSS HEAD SCREW	4X8, SS	7C32-0408	1	1	1	1	1		
	TRUSS HEAD SCREW	4X25, SS	7C32-0425	2	2	2	2	2		
4	SQUARE WASHER	BRASS	433537-02	1	1	1	1	1		
5	SCREW - GROUNDING	BRASS	433304-02	1	1	1	1	1		
6	TOP FRAME	GS	332443-01	1	1	1	1	1		
	T2 SCREW	4X8	7P31-0408	4	4	4	4	4		
7	SIDE FRAME	GS	332465G01	1	1	1	1	1		
	T2 SCREW	4X8	7P31-0408	2	2	2	2	2		
8	BULB HOLDER	PE	328919-01	1	1	1	1	-		
	BIN SWITCH	-	4A2430-01					1		
9	SPACER	PE	443545-01	1	1	1	1	-		
	SHIELD	-	3A1438-01					1		

MODEL: KM-280MAF, MAH TITLE: A. ICE CUBER ASSEMBLY										
INDEX NO.	DESCRIPTION	MATERIAL OR MODEL NUMBER	PART NUMBER	REQUIRED NUMBER						
				KM-280MAF				KM-280MAH		
				J-0 J-1	J-2	K-0	L-0	L-0		
10	THUMBSCREW	SS, ABS	415949G03	2	2	2	2	-		
		SS, ABS	415949G09					2		
11	BASE COVER	SS	321525G01	1	1	1	1	1		
12	TOP INSULATION	PP	215730G01	1	1	1	1	1		
13	FRONT INSULATION	PP	215731G01	1	1	1	1	1		
14	SIDE PANEL (R)	SS	211811G06	1	1	1	1	-		
		SS	2A2117G01					1		
	T2 SCREW	4X8, SS	7P32-0408	1	1	1	1	1		
15	CONTROL BOX COVER	GS	332466-01	1	1	1	1	1		
		T2 SCREW	4X8	7P31-0408	1	1	1	1	1	
16	FRONT PANEL	SS	323004G07	1	1	1	1	-		
		SS	2A2141G01					1		
17	LOUVER (B)	ABS	103121-03	1	1	1	1	-		
	LOUVER (A)	-	1A0547-01					1		
17a	PUSH RETAINER	-	4A2414-01					3		
18	SIDE PANEL (R) BASE	SS	212620-01	1	1	1	1	-		
		SS	2A2147-01					1		
19	TAPPING SCREW (BLACK)	STEEL, 4x8	433954-01	1	1	1	1	-		
20	TOP PANEL	SS (324859A03)	220465-01	1	1	1	1	-		
		(3A1890A01)	2A2133-01					1		
21	GASKET	PVC (324859A03)	427014-04	2	2	2	2	-		
		(3A1890A01)	427014-04					2		
22	INSULATION	PE FOAM (324859A03)	438012-01	1	1	1	1	-		
		(3A1890A01)	438012-01					1		

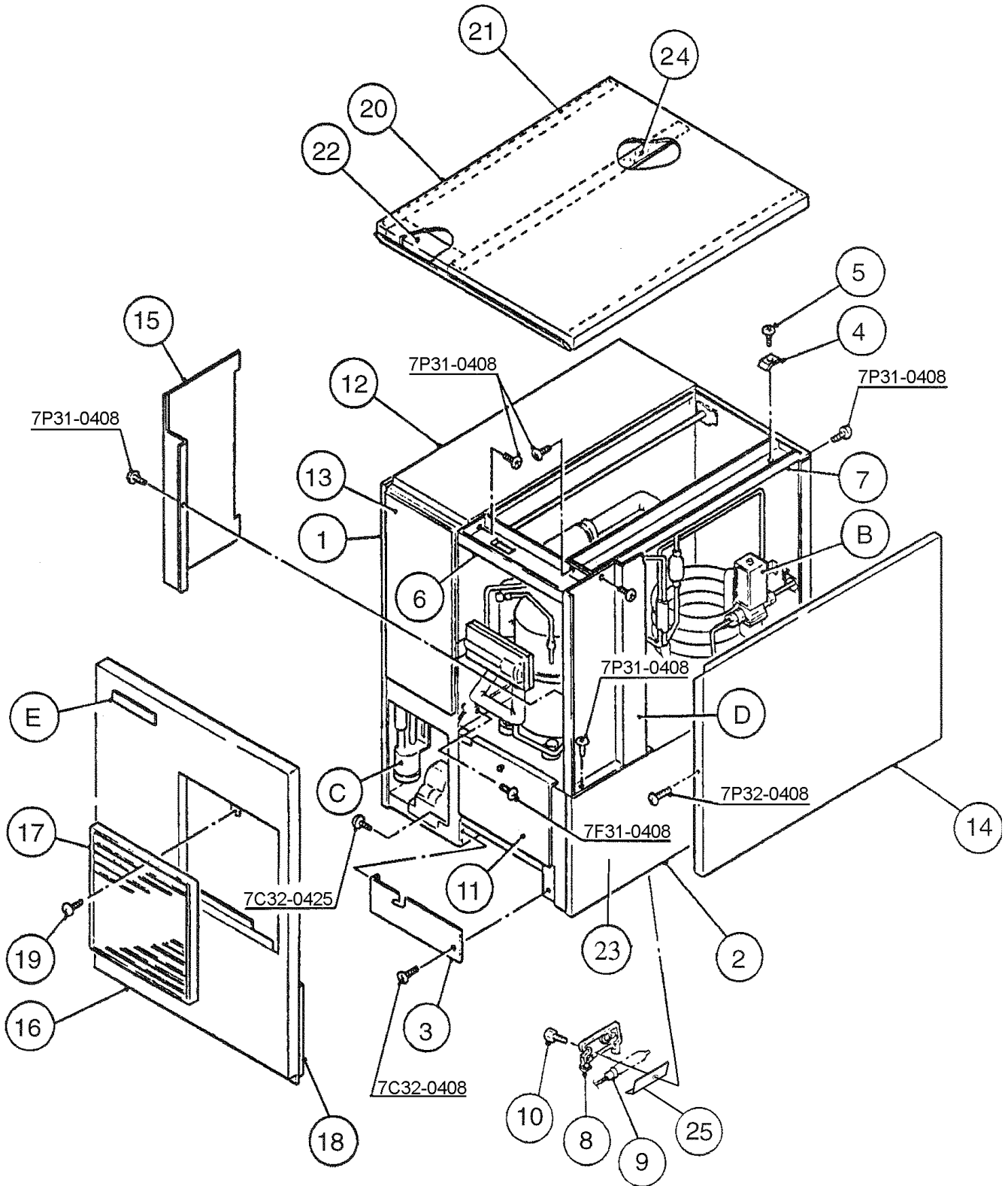

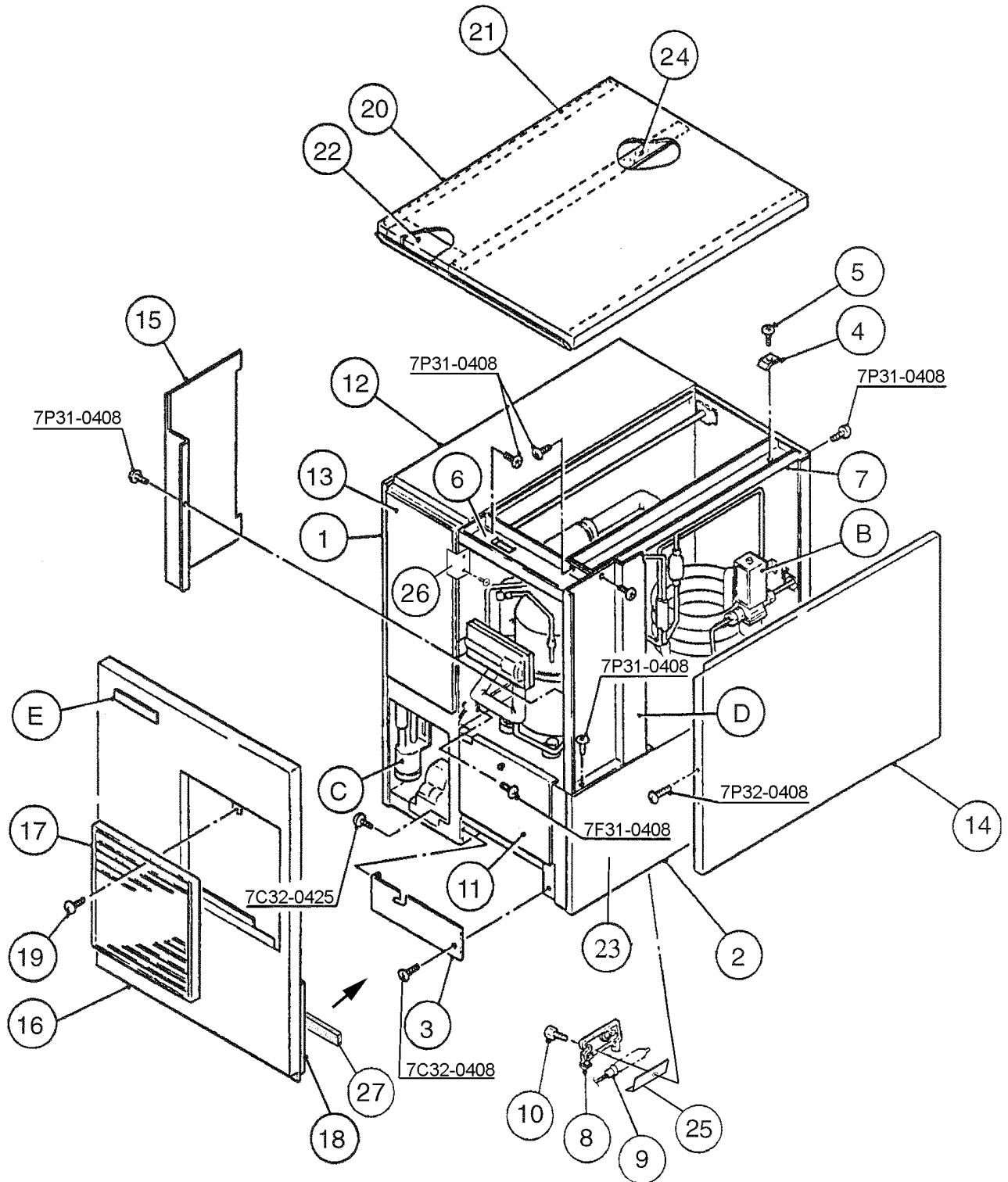

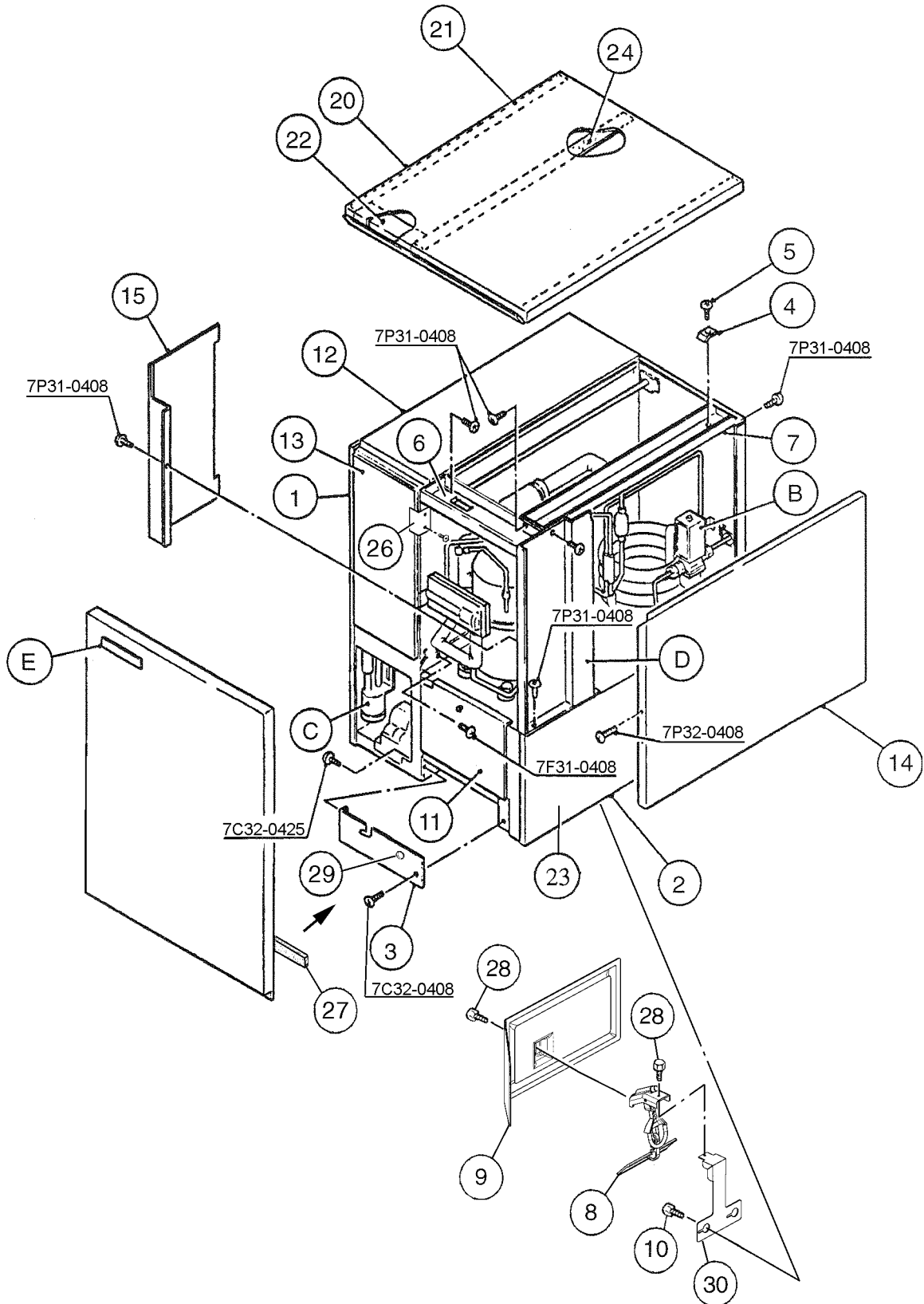

MODEL: KM-280MWF, MWH TITLE: A. ICE CUBER ASSEMBLY													
INDEX NO.	DESCRIPTION	MATERIAL OR MODEL NUMBER	PART NUMBER	REQUIRED NUMBER									
				KM-280MWF			KM-280MWH						
				J-0	J-2	K-0	L-0	L-0					
B	REFRIGERATION CIRCUIT	-	1A0395A01	1	1	1	1	1					
C	WATER CIRCUIT	HS-1207	1A0283A04	1	1	1	1	1					
D	CONTROL BOX ASSEMBLY	-	2A1423A02	1	1	x1							
		-	2A1960A02			o1	1	-					
		-	2A2247A02					1					
	T2 SCREW	4X8	7P31-0408	4	4	4	4	4					
E	LABEL LOCATION	-	3A1225A01	1	1	1	1	-					
		-	3A1904A01					1					
1	EVAP. CASE	HS-1010	1A0277G01	1	1	1	x1						
		-	1A0532G01				o1	-					
		-	1A0579G01					1					
2	BASE	-	2A1321G05	1	1	1	1	-					
		-	2A2146G05					1					
	FT SCREW	4X8	7F31-0408	7	7	7	7	7					
3	FRAME	ABS	3A0217G01	1	1	1	1	1					
	TRUSS HEAD SCREW	4X8, SS	7C32-0408	1	1	1	1	1					
	TRUSS HEAD SCREW	4X25, SS	7C32-0425	2	2	2	2	2					
4	SQUARE WASHER	BRASS	433537-02	1	1	1	1	1					
5	SCREW - GROUNDING	BRASS	433304-02	1	1	1	1	1					
6	TOP FRAME	GS	332443-01	1	1	1	1	1					
	T2 SCREW	4X8	7P31-0408	4	4	4	4	4					
7	SIDE FRAME	GS	332465G01	1	1	1	1	1					
	T2 SCREW	4X8	7P31-0408	2	2	2	2	2					
8	BULB HOLDER	PE	328919-01	1	1	1	1	-					
	BIN SWITCH	-	4A2430-01					1					
9	SPACER	PE	443545-01	1	1	1	1	-					
	SHIELD	-	3A1438-01					1					

MODEL: KM-280MWF, MWH TITLE: A. ICE CUBER ASSEMBLY										
INDEX NO.	DESCRIPTION	MATERIAL OR MODEL NUMBER	PART NUMBER	REQUIRED NUMBER						
				KM-280MWF				KM-280MWH		
				J-0 J-1	J-2	K-0	L-0	L-0		
10	THUMBSCREW	SS, ABS	415949G03	2	2	2	2	-		
		SS, ABS	415949G09					2		
11	BASE COVER	SS	321525G01	1	1	1	1	1		
12	TOP INSULATION	PP	215730G01	1	1	1	1	1		
13	FRONT INSULATION	PP	215731G01	1	1	1	1	1		
14	SIDE PANEL (R)	SS	211811G06	1	1	1	1	-		
		SS	2A2117G01					1		
	T2 SCREW	4X8, SS	7P32-0408	1	1	1	1	1		
15	CONTROL BOX COVER	GS	332466-01	1	1	1	1	1		
	T2 SCREW	4X8	7P31-0408	1	1	1	1	1		
16	FRONT PANEL	SS	323004G07	1	1	1	1	-		
		SS	2A2150G01					1		
17	LOUVER (B)	ABS	103121-03	1	1	1	1	-		
18	FRONT COVER	P.S	2A0182-01	1	1	1	1	-		
19	TAPPING SCREW (BLACK)	STEEL, 4x8	433954-01	1	1	1	1	-		
20	TOP PANEL	SS (324859A03)	220465-01	1	1	1	1	-		
		(3A1890A01)	2A2133-01					1		
21	GASKET	PVC (324859A03)	427014-04	2	2	2	2	-		
		(3A1890A01)	427014-04					2		
22	INSULATION	PE FOAM (324859A03)	438012-01	1	1	1	1	-		
		(3A1890A01)	438012-01					1		

HA

KM-280MAF, MAH

B. REFRIGERATION CIRCUIT (1/2)

J-0, J-1, J-2, K-0, L-0

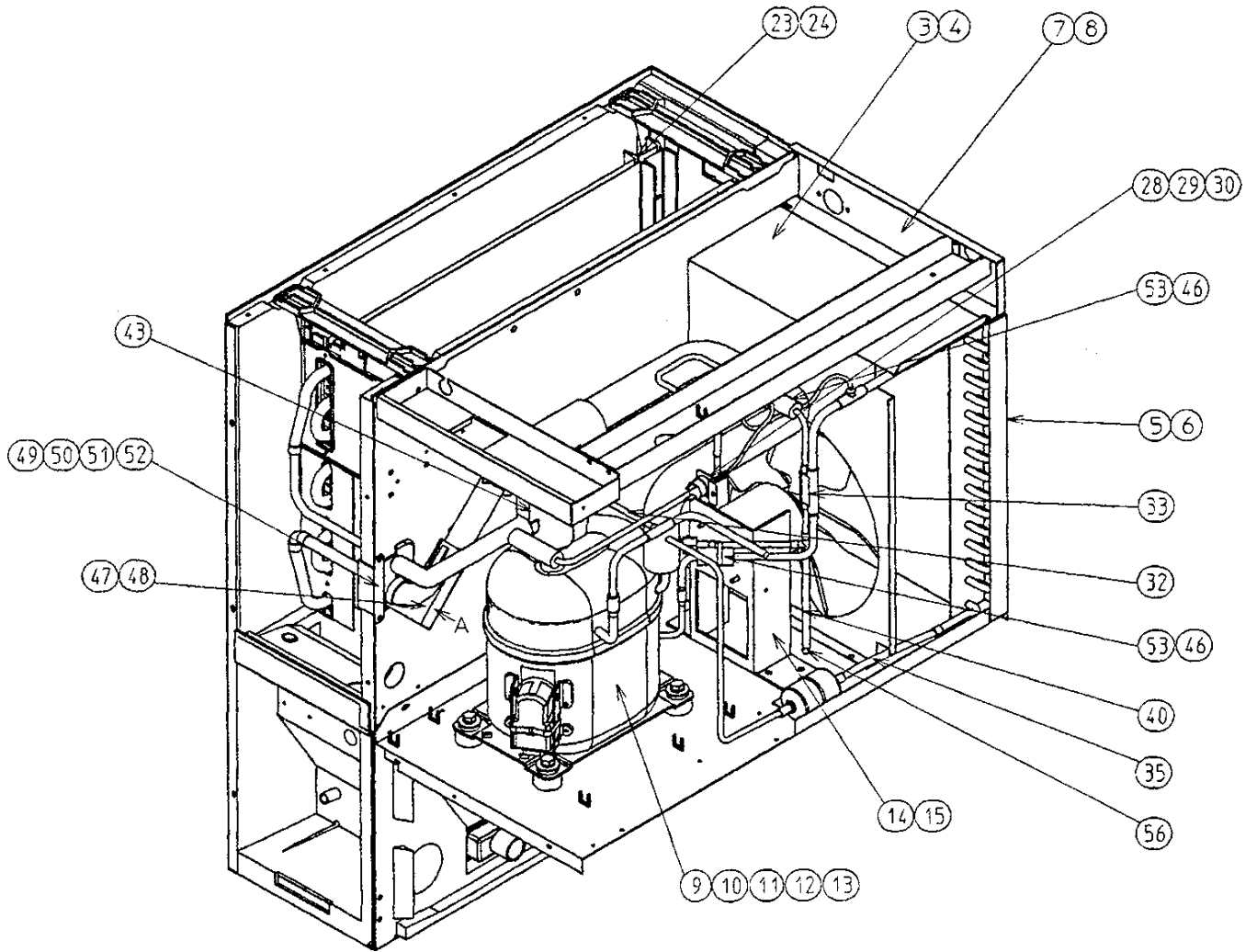

HA

KM-280MAF, MAH

B. REFRIGERATION CIRCUIT (2/2)

J-0, J-1, J-2, K-0, L-0

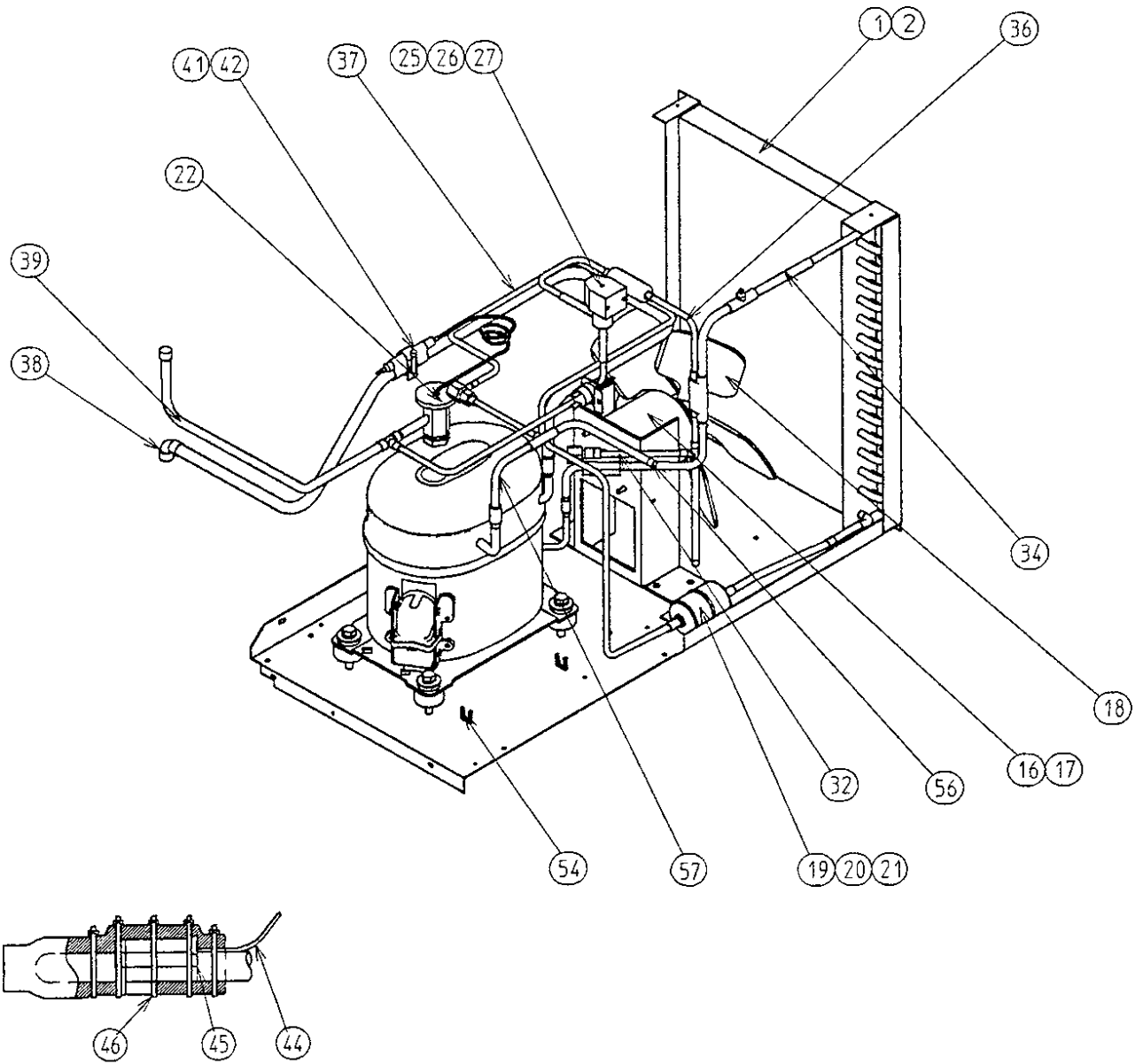

THERMISTOR ATTACHMENT

MODEL: KM-280MAF, MAH TITLE: B. REFRIGERATION CIRCUIT										
INDEX NO.	DESCRIPTION	MATERIAL OR MODEL NUMBER	PART NUMBER	REQUIRED NUMBER						
				KM-280MAF			KM-280MAH			
				J-0 J-1	J-2	K-0	L-0	L-0		
1	CONDENSER	-	2A0562-01	1	1	1	1	1		
2	HEX BOLT ASSEMBLY (LF)	4X12, SS	7B0230412	2	2	2	1	1		
3	SHROUD	GS	2A0606-01	1	1	1	1	1		
4	T2 SCREW	4X8	7P31-0408	2	2	2	2	2		
5	BARRIER	GS	433693-04	1	1	1	1	1		
6	T2 SCREW	4X8	7P31-0408	2	2	2	2	2		
7	REAR PANEL	GS	3A0562-01	1	1	1	1	1		
8	T2 SCREW	4X8	7P31-0408	3	3	3	3	3		
9	COMPRESSOR	AKA9438ZXA	4A1812-01	1	1	1	1	1		
10	BOLT	8x45	437889-01	4	4	4	4	4		
11	SPACER	027-0072-02	434404-01	4	4	4	4	4		
12	GROMMET	527-0039-04	434403-01	4	4	4	4	4		
13	MOTOR PROTECTOR	-	4A1860-01	1	1	1	1	1		
14	FAN MOTOR BRACKET	GS	327179-01	1	1	1	1	1		
15	HEX BOLT ASSEMBLY (LF)	5X12, SS	7B0230512	4	4	4	4	4		
16	FAN MOTOR	U90B1, 7190-1031	440911-01	1	1	1	1	1		
17	SELF-LOCKING NUT	NO. 8-32	7N21I0832	4	4	4	4	4		
18	FAN BLADE	AD10CW32	444898-01	1	1	1	1	1		
19	DRIER	CW-0325-S	4A1413-01	1	1	1	1	1		
20	DRIER BRACKET	GS	445847-01	1	1	1	1	1		
21	T2 SCREW	4X8	7P31-0408	1	1	1	1	1		
22	EXPANSION VALVE	AN1/2 SW70	4A1838-01	1	1	x1				
			4A1838-02			o1	1	1		
23	EVAPORATOR	-	1A0138G01	1	1	1	1	1		
24	T2 SCREW	4X16, SS	7P32-0416	4	4	4	4	4		
25	VALVE BODY	70	440352-01	1	1	1	1	1		
26	COIL - VALVE	ABS-25-1-HD-2	440353-01	1	1	1	1	1		
27	BOLT	4x6	440353F01	1	1	1	1	1		

MODEL: KM-280MAF, MAH TITLE: B. REFRIGERATION CIRCUIT										
INDEX NO.	DESCRIPTION	MATERIAL OR MODEL NUMBER	PART NUMBER	REQUIRED NUMBER						
				KM-280MAF			KM-280MAH			
				J-0 J-1	J-2	K-0	L-0	L-0		
28	PRESSURE SWITCH	ACB-1UB09	433441-07	1	1	1	2	2		
29	PRESSURE SWITCH BRACKET	GS	434938-01	1	1	1	1	1		
30	T2 SCREW	4X8	7P31-0408	1	1	1	1	1		
31	-	-	-							
32	ACCESS VALVE	FU180D001	446715-01	2	2	x2				
			457729-01			o2	2	2		
33	COPPER TUBE (A) - HIGH SIDE	COPPER	2A1435G01	1	1	1	1	1		
34	COPPER TUBE (B) - HIGH SIDE	COPPER	4A1823-01	1	1	1	1	1		
35	COPPER TUBE (C) - HIGH SIDE	COPPER	4A1819-01	1	1	1	1	1		
36	COPPER TUBE (D) - HIGH SIDE	COPPER	3A1238G01	1	1	1	1	1		
37	HEAT EXCHANGER	-	2A1478G01	1	1	1	1	1		
38	ELBOW	COPPER	417395-03	1	1	1	1	1		
39	COPPER TUBE - HOT GAS	COPPER	2A1425G01	1	1	1	1	1		
40	COPPER TUBE (J)	COPPER	4A1815G01	1	1	1	1	1		
41	HOLDER / EXP. VALVE – 1/2	SS	3A0112-01	1	1	1	1	1		
42	CLAMP	SS	443461-02	1	1	1	1	1		
43	EXPANSION VALVE COVER	PE FOAM	4A1168-01	1	1	1	1	1		
44	THERMISTOR	-	429006-03	1	1	1	1	1		
45	HOLDER - THERMISTOR	COPPER	427430-01	1	1	1	1	1		
46	CABLE TIE	CV-200 (PLT-2M)	7920-0010	14	14	14	14	14		
47	INSULATION - THERMISTOR (A)	PE FOAM	439368-01	1	1	1	1	1		
48	INSULATION - THERMISTOR (B)	PE FOAM	439368-02	1	1	1	1	1		
49	RUBBER INSULATION (A)	EPDM	3A1044-01	1	1	1	1	1		
50	RUBBER INSULATION (B)	EPDM	3A1045-01	1	1	1	1	1		
51	INSULATION HOLDER	-	4A1550-01	1	1	1	1	1		
52	T2 SCREW	4X8, SS	7P32-0408	2	2	2	2	2		

MODEL: KM-280MAF, MAH TITLE: B. REFRIGERATION CIRCUIT										
INDEX NO.	DESCRIPTION	MATERIAL OR MODEL NUMBER	PART NUMBER	REQUIRED NUMBER						
				KM-280MAF			KM-280MAH			
				J-0 J-1	J-2	K-0	L-0	L-0		
28	PRESSURE SWITCH	ACB-1UB09	433441-07	1	1	1	2	2		
29	PRESSURE SWITCH BRACKET	GS	434938-01	1	1	1	1	1		
30	T2 SCREW	4X8	7P31-0408	1	1	1	1	1		
31	-	-	-							
32	ACCESS VALVE	FU180D001	446715-01	2	2	x2				
33	COPPER TUBE (A) - HIGH SIDE	COPPER	2A1435G01	1	1	1	1	1		
34	COPPER TUBE (B) - HIGH SIDE	COPPER	4A1823-01	1	1	1	1	1		
35	COPPER TUBE (C) - HIGH SIDE	COPPER	4A1819-01	1	1	1	1	1		
36	COPPER TUBE (D) - HIGH SIDE	COPPER	3A1238G01	1	1	1	1	1		
37	HEAT EXCHANGER	-	2A1478G01	1	1	1	1	1		
38	ELBOW	COPPER	417395-03	1	1	1	1	1		
39	COPPER TUBE - HOT GAS	COPPER	2A1425G01	1	1	1	1	1		
40	COPPER TUBE (J)	COPPER	4A1815G01	1	1	1	1	1		
41	HOLDER / EXP. VALVE – 1/2	SS	3A0112-01	1	1	1	1	1		
42	CLAMP	SS	443461-02	1	1	1	1	1		
43	EXPANSION VALVE COVER	PE FOAM	4A1168-01	1	1	1	1	1		
44	THERMISTOR	-	429006-03	1	1	1	1	1		
45	HOLDER - THERMISTOR	COPPER	427430-01	1	1	1	1	1		
46	CABLE TIE	CV-200 (PLT-2M)	7920-0010	14	14	14	14	14		
47	INSULATION - THERMISTOR (A)	PE FOAM	439368-01	1	1	1	1	1		
48	INSULATION - THERMISTOR (B)	PE FOAM	439368-02	1	1	1	1	1		
49	RUBBER INSULATION (A)	EPDM	3A1044-01	1	1	1	1	1		
50	RUBBER INSULATION (B)	EPDM	3A1045-01	1	1	1	1	1		
51	INSULATION HOLDER	-	4A1550-01	1	1	1	1	1		
52	T2 SCREW	4X8, SS	7P32-0408	2	2	2	2	2		

HA

KM-280MWF, MWH

B. REFRIGERATION CIRCUIT (1/2)

J-0, J-1, J-2, K-0, L-0

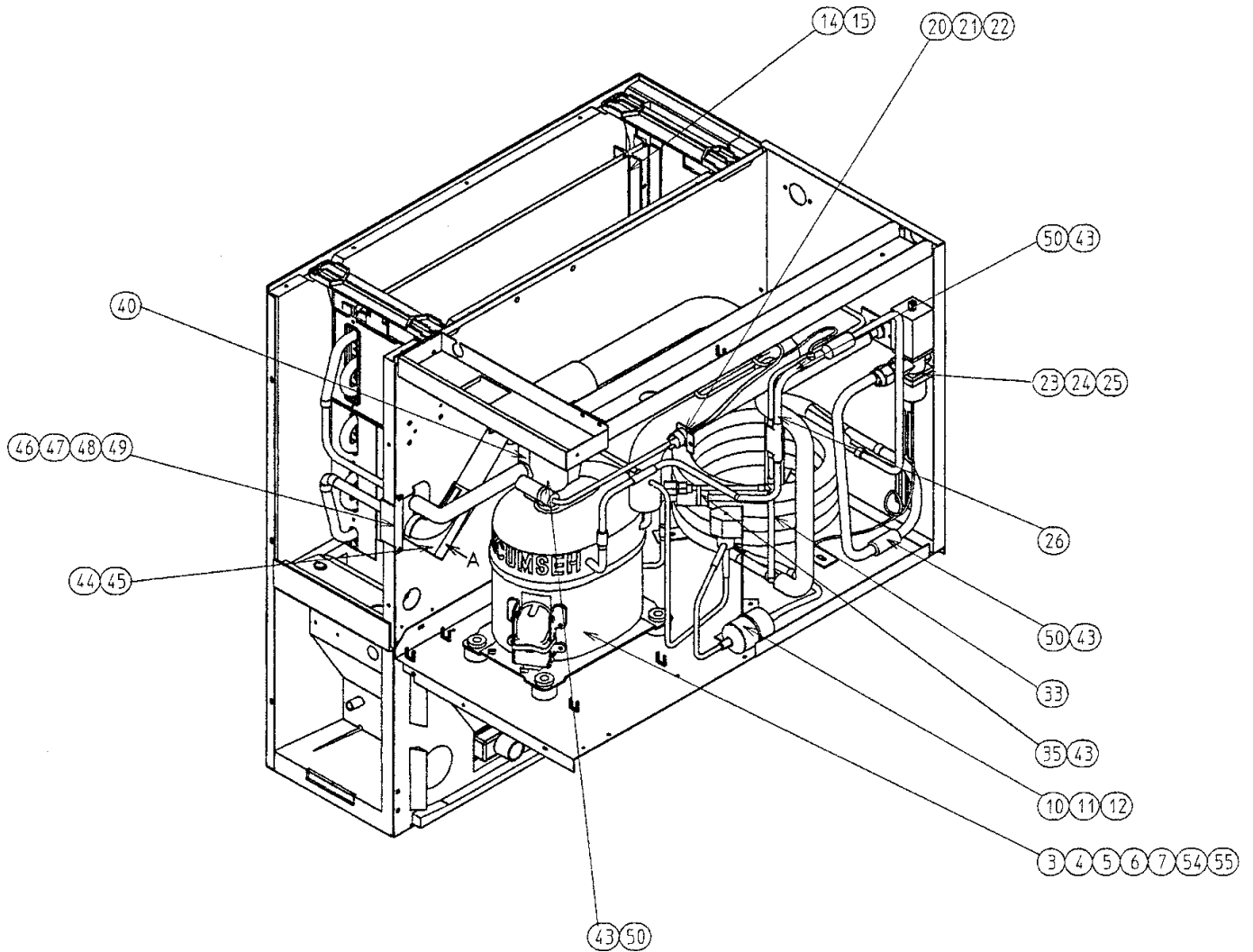

HA

KM-280MWF, MWH

B. REFRIGERATION CIRCUIT (2/2)

J-0, J-1, J-2, K-0, L-0

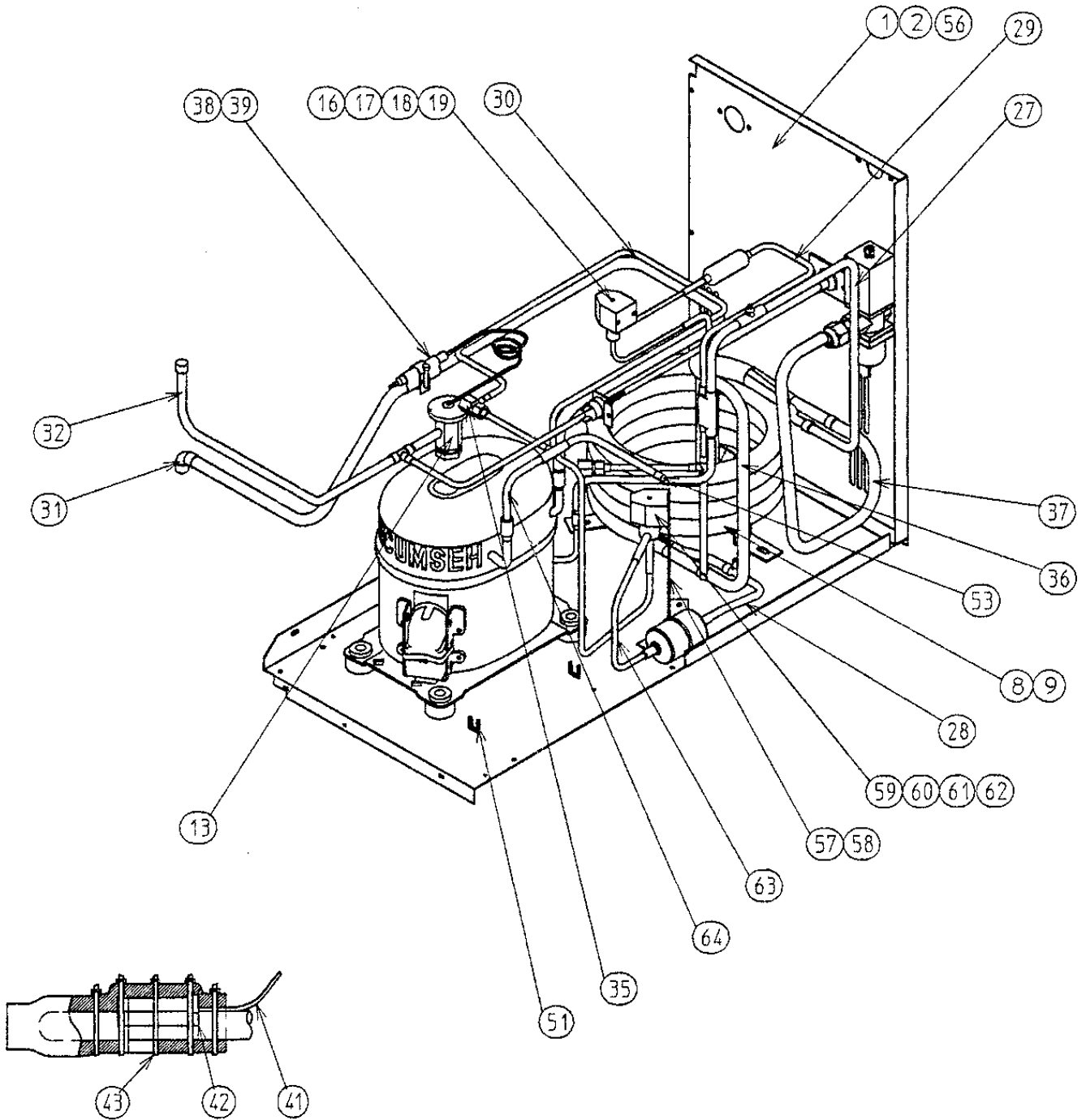

THERMISTOR ATTACHMENT

MODEL: KM-280MWF, MWH TITLE: B. REFRIGERATION CIRCUIT											
INDEX NO.	DESCRIPTION	MATERIAL OR MODEL NUMBER	PART NUMBER	REQUIRED NUMBER							
				KM-280MWF				KM-280MWH			
				J-0 J-1	J-2	K-0	L-0	L-0			
1	REAR PANEL	GS	2A1426-01	1	1	1	1	1			
2	T2 SCREW	4X8	7P31-0408	5	5	5	5	5			
3	COMPRESSOR	AKA9438ZXA	4A1812-01	1	1	1	1	1			
4	BOLT	8x45	437889-01	4	4	4	4	4			
5	SPACER	027-0072-02	434404-01	4	4	4	4	4			
6	GROMMET	527-0039-04	434403-01	4	4	4	4	4			
7	MOTOR PROTECTOR	-	4A1860-01	1	1	1	1	1			
8	CONDENSER - WATER-COOLED	-	2A1429-01	1	1	1	1	-			
		-	2A1429-02					1			
9	HEX BOLT ASSEMBLY (LF)	4X12, SS	7B0230412	3	3	3	3	3			
10	DRIER	CW-0325-S	4A1413-01	1	1	1	1	1			
11	DRIER BRACKET	GS	445847-01	1	1	1	1	1			
12	T2 SCREW	4X8, SS	7P32-0408	4	4	4	4	4			
13	EXPANSION VALVE	AN1/2 SW70	4A1838-01	1	1	x1					
		-	4A1838-02			o1	1	1			
14	EVAPORATOR	-	1A0138G01	1	1	1	1	1			
15	T2 SCREW	4X8, SS	7P32-0408	4	4	4	4	4			
16	VALVE BODY	-	3U0151-01	1	1	1	1	1			
17	COIL - VALVE	-	3U0151F01	1	1	1	1	1			
18	BOLT	-	3U0151F02	1	1	1	1	1			
19	TRUSS HEAD SCREW	4X6	7C31-0406	2	2	2	2	2			
20	PRESSURE SWITCH	ACB-2UB04	433441-05	1	1	1	1	1			
21	PRESSURE SWITCH BRACKET	GS	434938-01	1	1	1	1	1			
22	T2 SCREW	4X8	7P31-0408	1	1	1	1	1			
23	WATER REGULATOR	V46DA-3	4A0911-03	1	1	1	1	1			
24	TRUSS HEAD SCREW	4X8	7C31-0408	2	2	2	2	2			
25	MALE CONNECTOR	-	4A1087-01	1	1	1	1	1			
26	COPPER TUBE (A) - HIGH SIDE	COPPER	2A1435G01	1	1	1	1	1			
27	COPPER TUBE (B) - HIGH SIDE	COPPER	3A1249-01	1	1	1	1	1			

HA

MODEL: KM-280MWF, MWH TITLE: B. REFRIGERATION CIRCUIT											
INDEX NO.	DESCRIPTION	MATERIAL OR MODEL NUMBER	PART NUMBER	REQUIRED NUMBER							
				KM-280MWF				KM-280MWH			
				J-0 J-1	J-2	K-0	L-0	L-0			
28	COPPER TUBE (C) - HIGH SIDE	COPPER	4A1829G01	1	1	1	1	1			
29	COPPER TUBE (D) - HIGH SIDE	COPPER	3A1239G01	1	1	1	1	1			
30	HEAT EXCHANGER	-	2A1581G01	1	1	1	1	1			
31	ELBOW	COPPER	417395-03	1	1	1	1	1			
32	COPPER TUBE (A) - HOT GAS	COPPER	2A1427G01	1	1	1	1	1			
33	COPPER TUBE (J)	COPPER	4A1815G01	1	1	1	1	1			
34	-	-	-								
35	ACCESS VALVE	FU180D001	446715-01	2	2	x2					
		-	457729-01			o2	2	2			
36	COPPER TUBE (A) - WATER CIRCUIT	COPPER	3A1251G01	1	1	1	1	1			
37	COPPER TUBE (B) - WATER CIRCUIT	COPPER	3A0466G01	1	1	1	1	1			
38	HOLDER/EXP. VALVE - 1/2	-	3A0112-01	1	1	1	1	1			
39	CLAMP	SS	443461-02	1	1	1	1	1			
40	EXPANSION VALVE COVER	PE FOAM	4A1168-01	1	1	1	1	1			
41	THERMISTOR	-	429006-03	1	1	1	1	1			
42	HOLDER - THERMISTOR	-	427430-01	1	1	1	1	1			
43	CABLE TIE	CV-200 (PLT-2N)	7920-0010	15	15	15	15	15			
44	INSULATION - THERMISTOR (A)	PE FOAM	439368-01	1	1	1	1	1			
45	INSULATION - THERMISTOR (B)	PE FOAM	439368-02	1	1	1	1	1			
46	RUBBER INSULATION (A)	EPDM	3A1044-01	1	1	1	1	1			
47	RUBBER INSULATION (B)	EPDM	3A1045-01	1	1	1	1	1			
48	INSULATION HOLDER		4A1550-01	1	1	1	1	1			
49	T2 SCREW	4X8, SS	7P32-0408	2	2	2	2	2			
50	INSULATION TUBE	L=40	7762-1020	2	2	2	2	2			
51	WIRE SADDLE	VWS4238-C	4A0338-02	9	9	9	9	9			
52	-	-	-								
53	END CAP	-	4A1413F01	2	2	2	2	2			

HA

KM-280MAF, MWF, MAH, MWH

C. WATER CIRCUIT

J-0, J-1, J-2, K-0, L-0

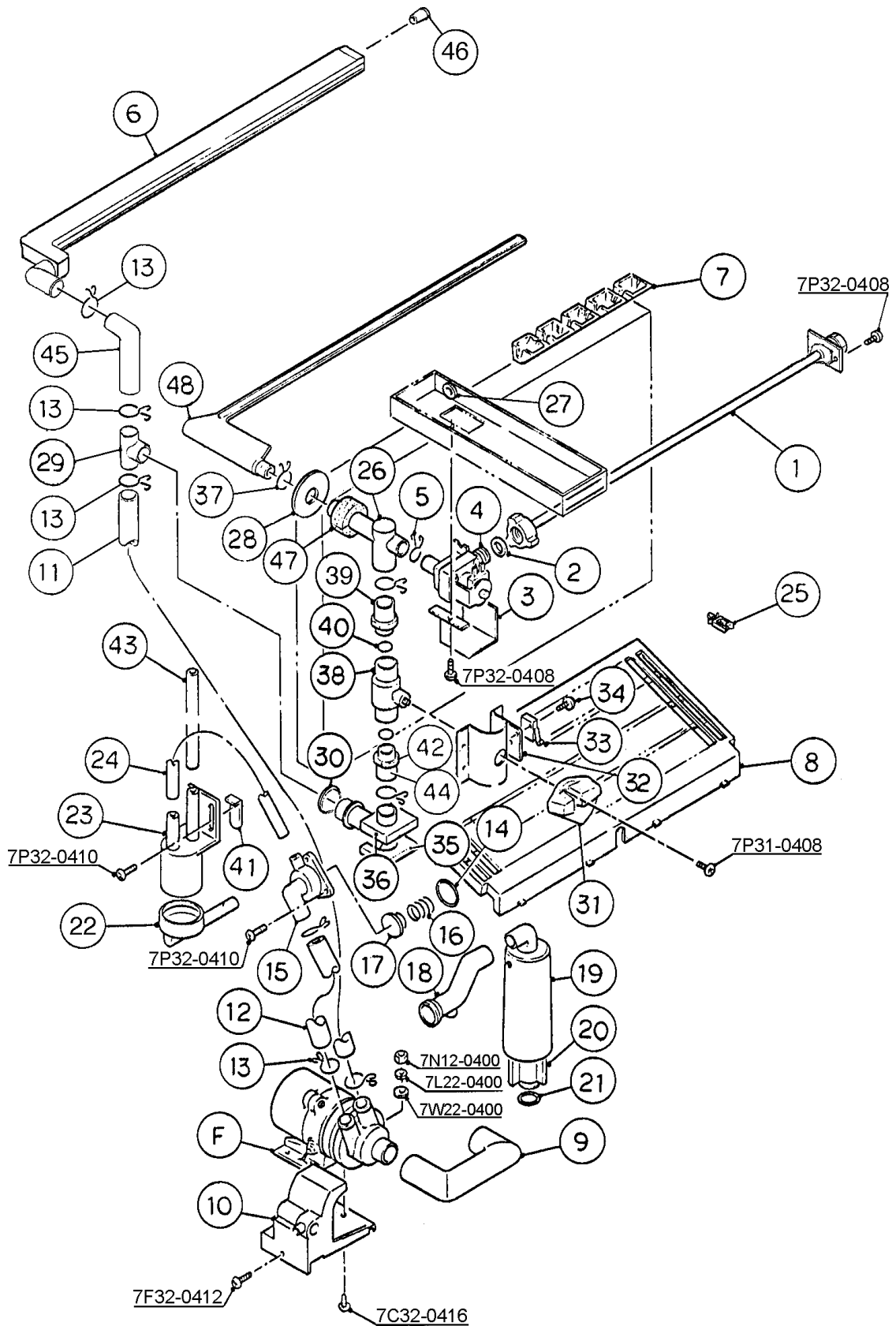

MODEL: KM-280MAF, MWF, MAH, MWH TITLE: C. WATER CIRCUIT													
INDEX NO.	DESCRIPTION	MATERIAL OR MODEL NUMBER	PART NUMBER	REQUIRED NUMBER									
				KM-280MAF			KM-280MAH						
				KM-280MWF			KM-280MWH						
J-0	J-2	K-0	L-0	L-0									
J-1													
F	PUMP MOTOR ASSEMBLY	HS-0127	3A1092A01	1	1	1	1	1					
	TRUSS HEAD SCREW	4X16, SS	7C32-0415	1	1	1	1	1					
	FLAT WASHER	M4, SS	7W22-0400	1	1	1	1	1					
	SPLIT LOCK WASHER	M4, SS	7L22-0400	1	1	1	1	1					
	HEX NUT	M4, SS	7N12-0400	1	1	1	1	1					
1	WATER SUPPLY PIPE	COPPER	4A0768G04	1	1	1	1	1					
	T2 SCREW	4X8	7P31-0408	2	2	2	2	2					
2	RUBBER GASKET	NR	413854-03	1	1	1	1	1					
3	WATER VALVE BRACKET	GS	321443-01	1	1	1	1	1					
	T2 SCREW	4X8	7P31-0408	1	1	1	1	1					
4	WATER VALVE	J248-647	3U0150-01	1	1	1	1	1					
5	HOSE CLAMP	SS, 18MM	427443-05	1	1	1	1	1					
6	SPRAY TUBE	PE	1A0222-02	1	1	1	1	1					
7	SPRAY GUIDE (A)	PE	208586-01	6	6	6	6	6					
8	CUBE GUIDE	ABS	212088-01	1	1	1	1	1					
9	SUCTION HOSE	EPDM	4A1380-01	1	1	1	1	1					
10	PUMP MOTOR BRACKET	PC	211408-01	1	1	1	1	1					
	FLAT HEAD SCREW	4X12, SS	7F32-0412	1	1	1	1	1					
11	VINYL HOSE	L=250+10/-0	7716-2025	1	1	1	1	1					
12	VINYL HOSE	L=110	7716-2025	1	1	1	1	1					
13	HOSE CLAMP	SS, 25MM	427443-03	9	9	9	9	9					
14	"O" RING	1AG35	7611-G035	1	1	1	1	1					
15	VALVE HOUSING - DRAIN	ABS	321001-01	1	1	1	1	1					
	T2 SCREW	4X10, SS	7P32-0410	3	3	3	3	3					
16	SPRING	SS	3A1091-01	1	1	1	1	1					
17	VALVE SHEET	EPDM	433705-01	1	1	1	1	1					
18	DRAIN HOSE	SANTOPRENE	433468-01	1	1	1	1	1					
19	OVERFLOW CAP	PE	321002-01	1	1	1	1	1					
20	OVERFLOW PIPE	ABS	430722-05	1	1	1	1	1					

MODEL: KM-280MAF, MWF, MAH, MWH TITLE: C. WATER CIRCUIT										
INDEX NO.	DESCRIPTION	MATERIAL OR MODEL NUMBER	PART NUMBER	REQUIRED NUMBER						
				KM-280MAF			KM-280MAH			
				J-0	J-2	K-0	L-0	L-0		
21	"O" RING	EPDM	4A1234-01	1	1	1	1	1		
22	CONNECTOR – FLOAT SWITCH	EPDM	3A1325-01	1	1	x1				
		-	426799-01			o1	1	1		
23	FLOAT SWITCH	163795	4A0886-01	1	1	1	1	1		
	T2 SCREW	4X12, SS	7P32-0412	2	2	2	2	2		
24	SILICONE HOSE	L=140	7730I3896	1	1	1	1	1		
25	WIRE SADDLE	VWS4238-C	4A0338-02	4	4	4	4	4		
26	TEE	SANTOPRENE	4A0177-01	1	1	1	1	1		
27	BUSHING	OCB-750	428394-01	1	1	1	1	1		
28	FLANGE	EPDM	439267-01	1	1	1	1	1		
29	DISTRIBUTOR	EPDM	432426-01	1	1	1	1	1		
30	RUBBER RING	EPDM	439236-01	1	1	1	1	1		
31	HANDLE	JH1352	215383-01	1	1	1	1	1		
	T2 SCREW	4X8	7P31-0408	1	1	1	1	1		
32	VALVE HOLDER	GS	3A1178-01	1	1	1	1	1		
	FT SCREW	4X8	7F31-0408	3	3	3	3	3		
33	MICROSWITCH	V3L-111-08	4A0365-01	1	1	1	1	1		
34	TAPPING SCREW	3X14	431415-02	2	2	2	2	2		
35	CORNER INSULATION (A)	PE FOAM	439376-01	1	1	1	1	1		
36	CORNER INSULATION (B)	PE FOAM	439392-01	1	1	1	1	1		
37	HOSE CLAMP	SS, 20 MM	427443-06	1	1	1	1	1		
38	BALL VALVE	(S-0761), PVC	439293-01	1	1	1	1	1		
39	MALE ADAPTOR	ABS	325826-01	2	2	2	2	2		
40	"O" RING	1AP18	7611-P018	2	2	2	2	2		
41	FLOAT SWITCH STOP	SS	4A0137-01	1	1	1	1	1		
42	INSULATION TUBE	L=190	7762-2636	1	1	1	1	1		
43	SILICONE HOSE	L=140	7730I3812	1	1	1	1	1		
44	RUBBER HOSE (D)	EPDM	4A1551-04	1	1	1	1	1		
45	RUBBER HOSE (C)	SANTOPRENE	4A1551-03	1	1	1	1	1		

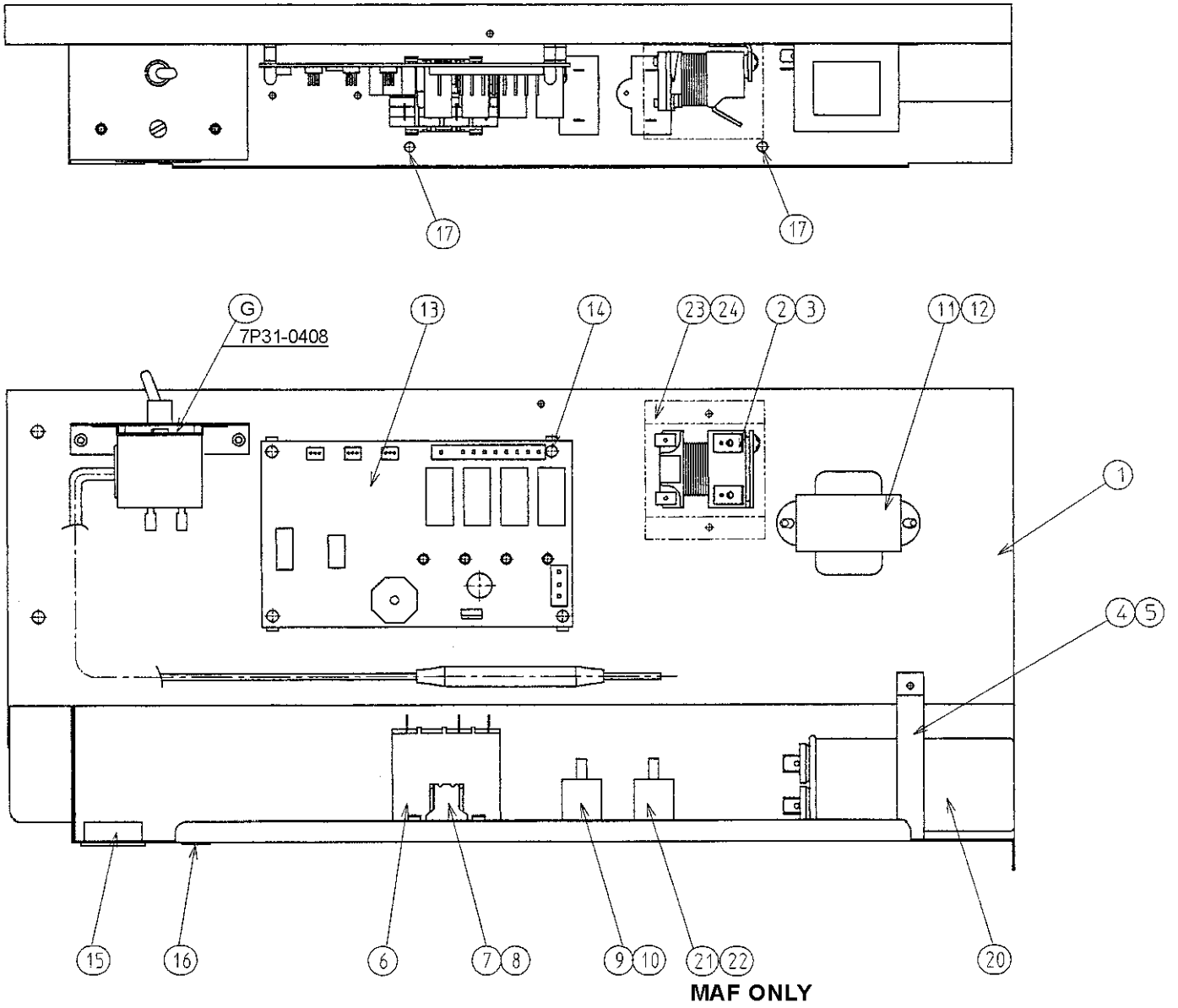

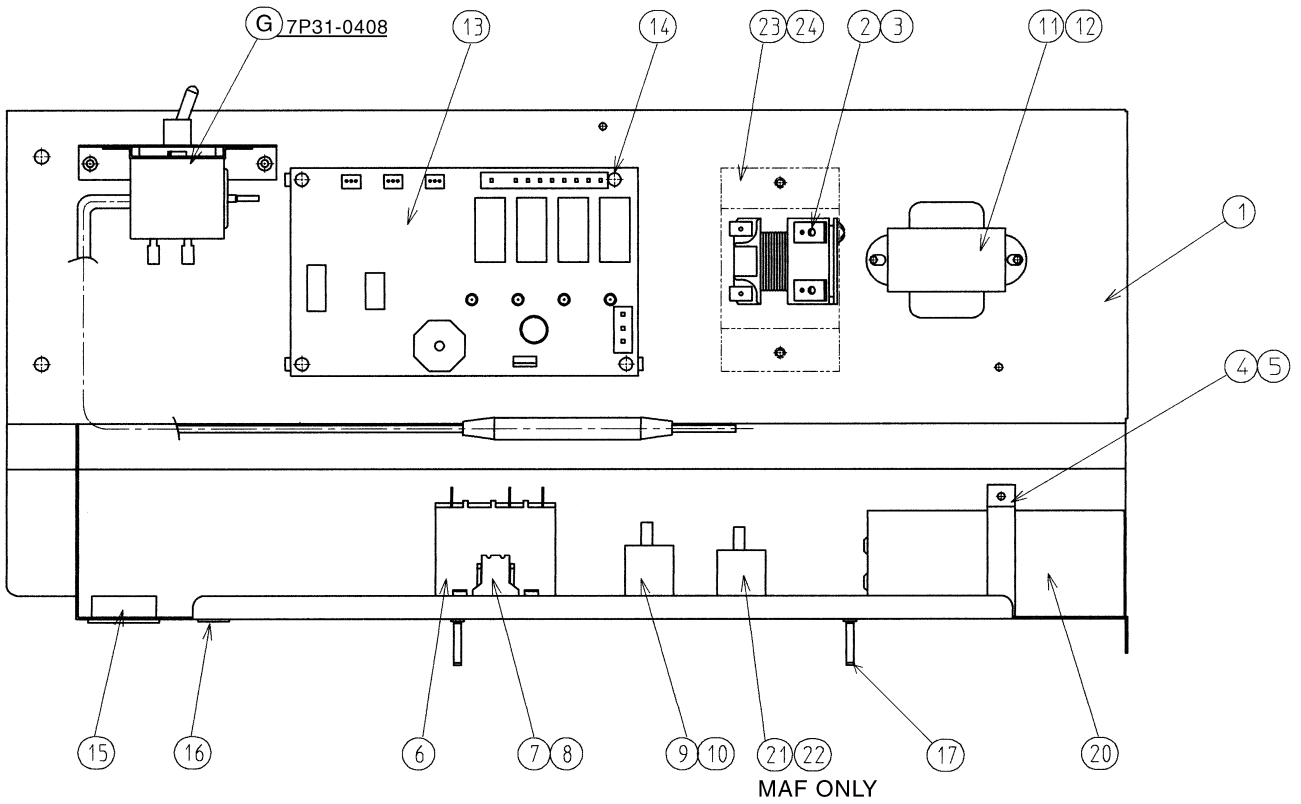
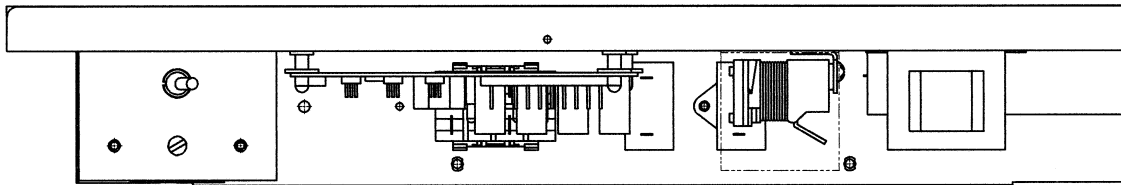

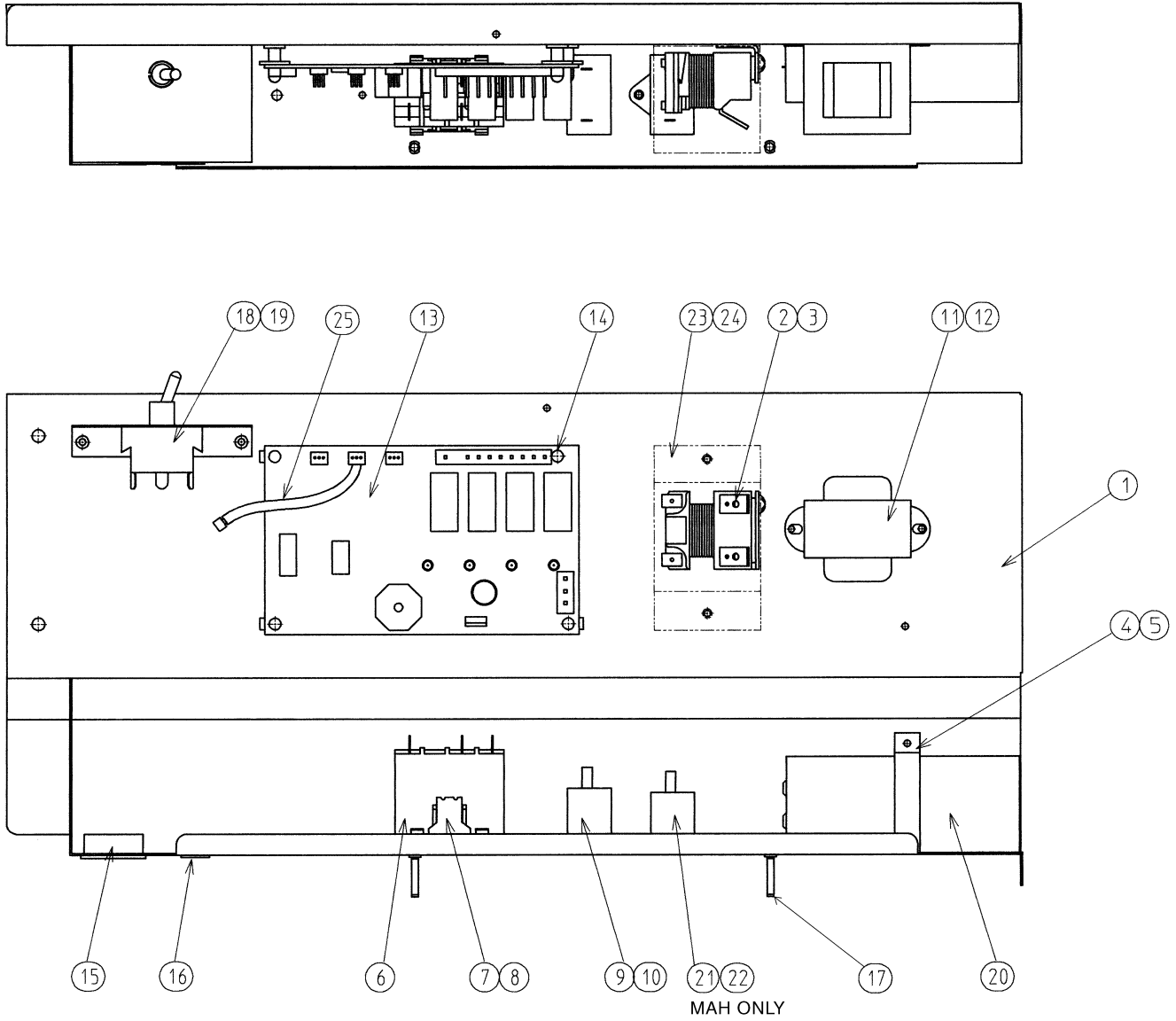

MODEL: KM-280MAF, MWF, MAH, MWH TITLE: D. CONTROL BOX ASSEMBLY													
INDEX NO.	DESCRIPTION	MATERIAL OR MODEL NUMBER	PART NUMBER	REQUIRED NUMBER									
				KM-280MAF			KM-280MAH						
				KM-280MWF			KM-280MWH						
J-0	J-2	K-0	L-0	L-0									
J-1													
G	CONTROL ASSEMBLY	-	4A0388A01	1	1	1	1	-					
		-	4A2513A01					1					
	T2 SCREW	4X8	7P31-0408	2	2	2	2	2					
1	CONTROL BOX	-	3A1270G01	1	1	x1							
		-	2A1851-01			o1	1	1					
2	STARTER	3ARR2-KCR181S	4A1709-01	1	1	1	1	1					
3	T2 SCREW	4X8	7P31-0408	1	1	1	1	-					
	M4 SCREW	-						1					
4	STRAP	GS	434580-15	1	1	x1							
		GS	434580-21			o1	1	-					
		GS	434580-02					1					
5	T2 SCREW	4X8	7P31-0408	1	1	1	1	1					
6	MAGNETIC CONTACTOR	VC-20	428393-01	1	1	1	1	1					
7	BRACKET	-	428393F01	1	1	1	1	1					
8	T2 SCREW	4X8	7P31-0408	2	2	2	2	2					
9	CAPACITOR	250 VAC, 5.5 MFD	443192-03	1	1	1	1	1					
10	T2 SCREW	4X10	7P31-0410	1	1	1	1	1					
11	TRANSFORMER	-	3A0172-01	1	1	1	1	1					
12	T2 SCREW	4X8	7P31-0408	2	2	2	2	2					
13	CONTROLLER BOARD	HOS-001A	2A1410-01	1	1	1	1	1					
14	BOARD SUPPORT	CBLS37-M	4A0336-03	4	4	4	4	4					
15	BUSHING	SB-1093-15	420470-03	1	1	1	1	1					
16	BUSHING	OCB-500	428394-02	1	1	1	1	1					
17	WIRE SADDLE	-	4A0338-02	2	2	2	2	2					
18	-	-	-										
19	-	-	-										
20	CAPACITOR – STARTING	125 VAC, 378-454 MFD	3A0076-16	1	1	1							

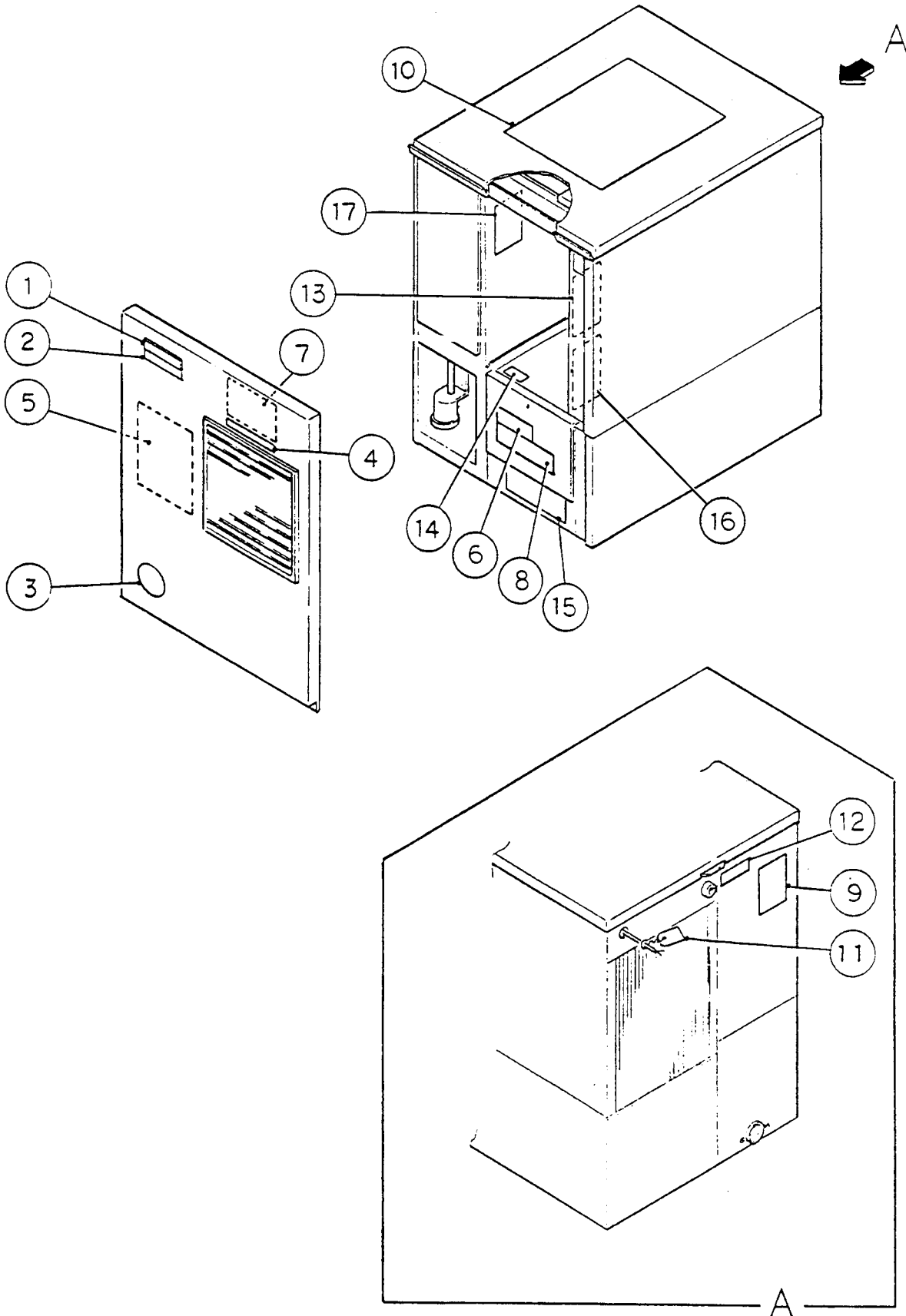

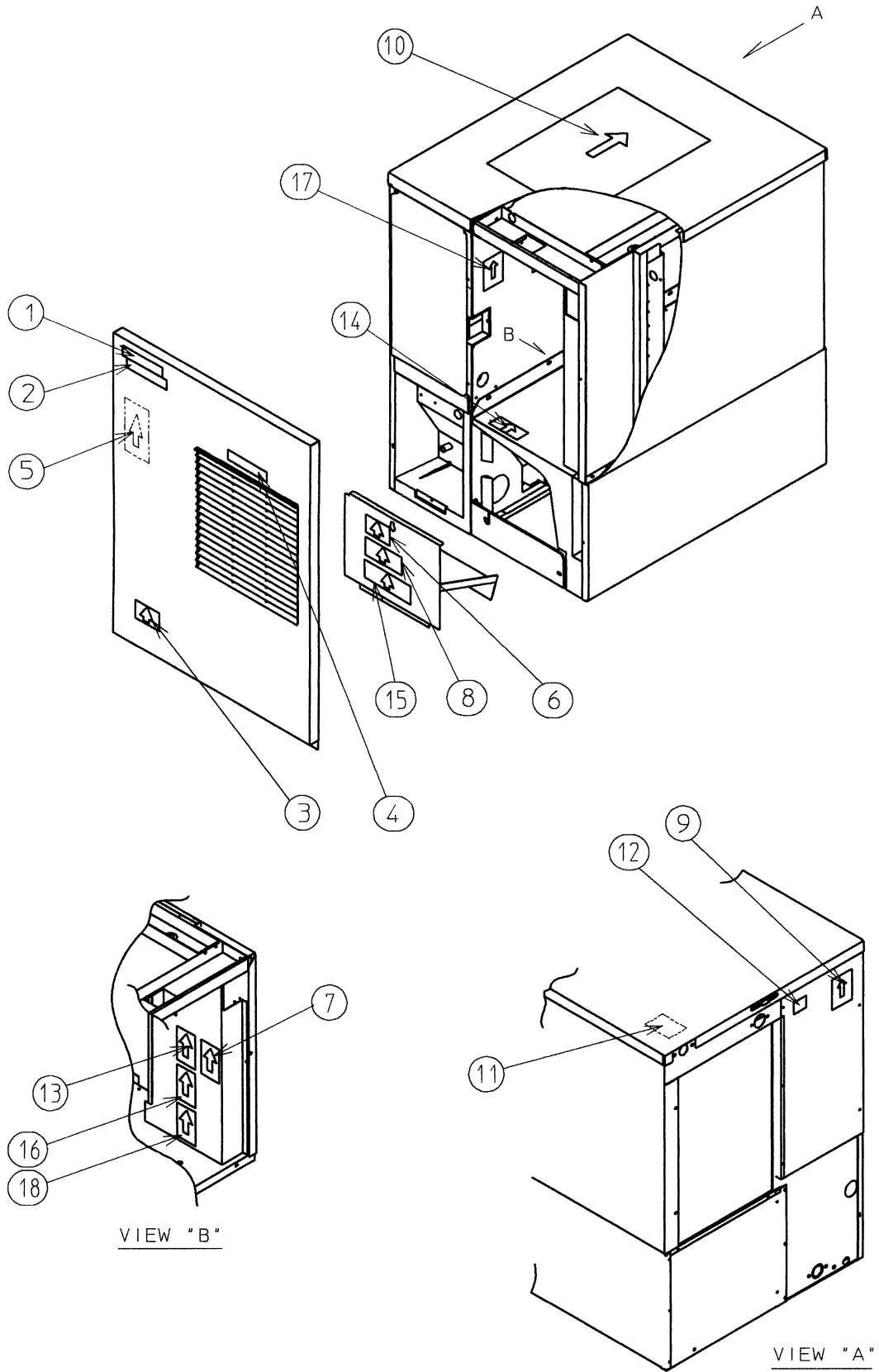

MODEL: KM-280MAF, MAH TITLE: E. LABEL LOCATION										
INDEX NO.	DESCRIPTION	MATERIAL OR MODEL NUMBER	PART NUMBER	REQUIRED NUMBER						
				KM-280MAF			KM-280MAH			
				J-0 J-1	J-2	K-0	L-0	L-0		
1	EMBLEM	PETP FILM	4A0560-01	1	1	1	1	1		
2	MODEL NUMBER LABEL	PETP FILM	4A1233-36	1	1	1	1	-		
		PETP FILM	4A2356-35					1		
3	LABEL – PENGUIN – HA (R)	PETP FILM	4A0526-01	1	1	1	1	1		
4	LABEL – AIR FILTER	PETP FILM	426177-01	1	1	1	1	1		
5	MAINTENANCE LABEL	PVC FILM	326218-01	1	1	1	1	1		
6	CAUTION LABEL (F)	PVC FILM	439146-01	1	1	1	1	1		
7	WIRING LABEL	PVC FILM	3A1401-01	1	1	1	1	-		
		PVC FILM	3A1982-01					1		
8	CAUTION LABEL (K)	PVC FILM	439150-01	1	1	1	1	1		
9	NAMEPLATE	PES FILM	4A1806-01	1	1	1	1	-		
		PES FILM	4A2397-01					1		
10	INSTRUCTION SHEET	PAPER	2A1310-01	1	1	1	1	-		
		PAPER	2A2143-01					1		
11	TAG – WARNING: ELECTRICAL CONNECTION	PAPER	435005-01	1	1	1	1	1		
12	INSTRUCTION LABEL	PVC FILM	444575-01	1	1	1	1	1		
13	MANUAL LABEL	PVC FILM	446564-01	1	1	1	1	-		
		PVC FILM	4A2530-01					1		
14	LABEL – R404A	PES FILM	4A0960-01	1	1	1	1	1		
15	OPERATION LABEL – VALVE	PVC FILM	439541-01	1	1	1	1	1		
16	LABEL – CONTROL BOARD	PVC FILM	3A1272-01	1	1	1	1	1		
17	RATING LABEL	PES FILM	4A1808-01	1	1	1	1	-		
		PES FILM	4A2405-01					1		
18	LABEL (B) – CONTROL BOARD	-	4A2528-01					1		

HA

KM-280MWF

E. LABEL LOCATION

J-0, J-1, J-2, K-0, L-0

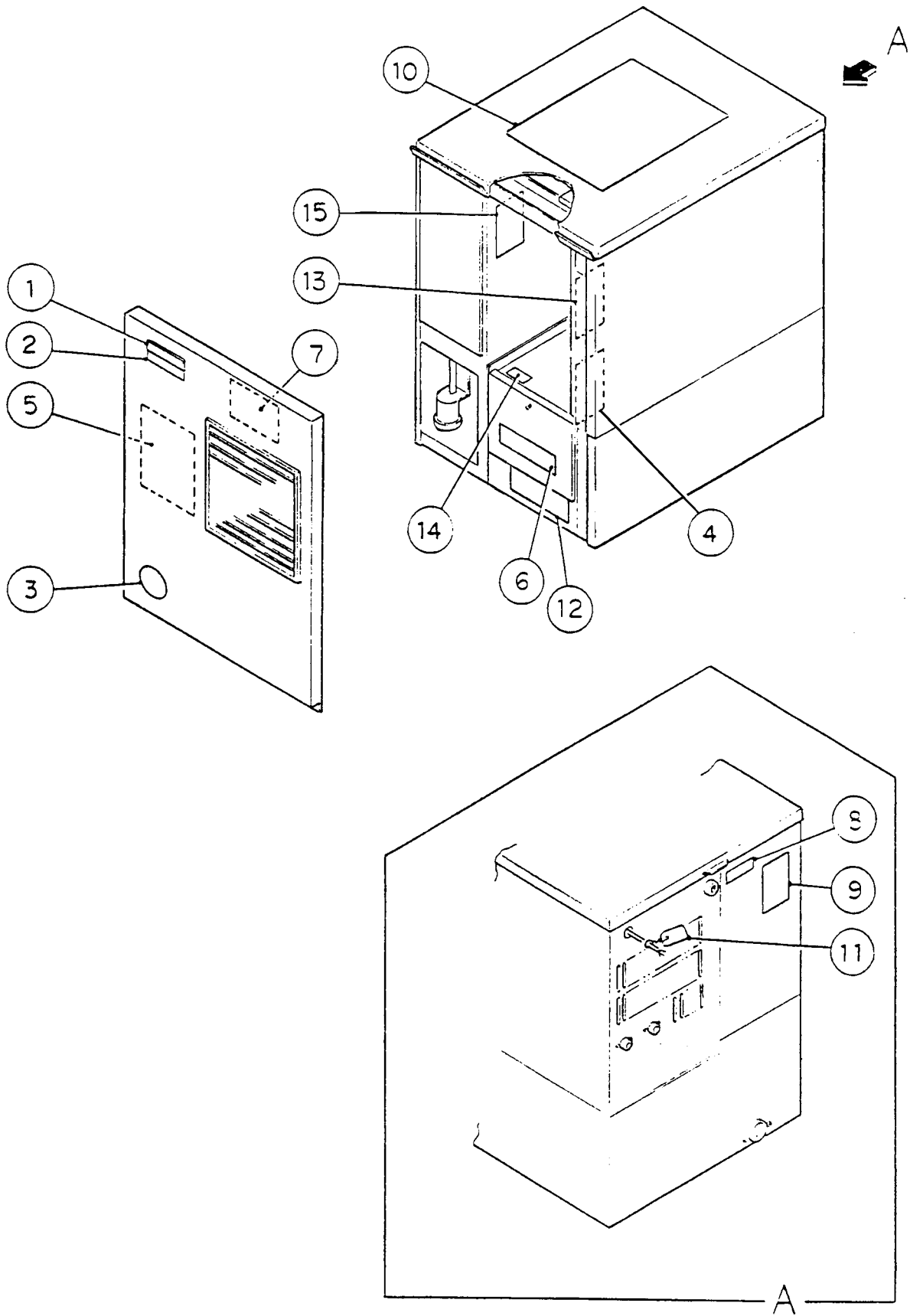

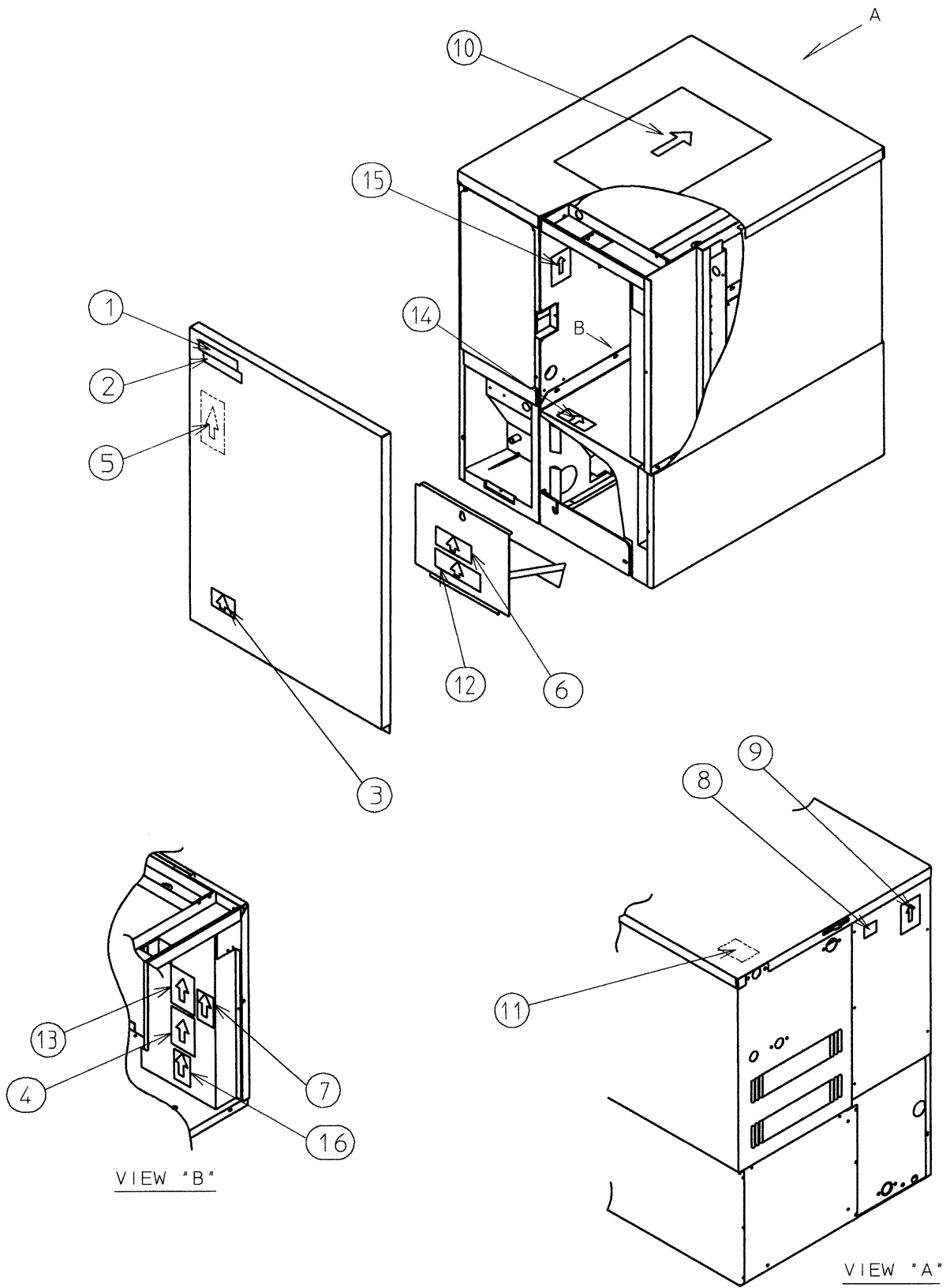

MODEL: KM-280MWF, MWH TITLE: E. LABEL LOCATION													
INDEX NO.	DESCRIPTION	MATERIAL OR MODEL NUMBER	PART NUMBER	REQUIRED NUMBER									
				KM-280MWF			KM-280MWH						
				J-0 J-1	J-2	K-0	L-0	L-0					
1	EMBLEM	PETP FILM	4A0560-01	1	1	1	1	1					
2	MODEL NUMBER LABEL	PETP FILM	4A1233-37	1	1	1	1	-					
		PETP FILM	4A2356-36					1					
3	LABEL – PENGUIN – HA (R)	PETP FILM	4A0526-01	1	1	1	1	1					
4	LABEL – CONTROL BOARD	PVC FILM	3A1272-01	1	1	1	1	1					
5	MAINTENANCE LABEL	PVC FILM	326218-01	1	1	1	1	1					
6	CAUTION LABEL (K)	PVC FILM	439150-01	1	1	1	1	1					
7	WIRING LABEL	PVC FILM	3A1401-01	1	1	1	1	-					
		PVC FILM	3A1982-01					1					
8	INSTRUCTION LABEL	PVC FILM	444575-01	1	1	1	1	1					
9	NAMEPLATE	PES FILM	4A1807-01	1	1	1	1	-					
		PES FILM	4A2398-01					1					
10	INSTRUCTION SHEET	PAPER	2A1310-01	1	1	1	1	-					
		PAPER	2A2143-01					1					
11	TAG – WARNING: ELECTRICAL CONNECTION	PAPER	435005-01	1	1	1	1	1					
12	OPERATION LABEL – VALVE	PVC FILM	439541-01	1	1	1	1	1					
13	MANUAL LABEL	PVC FILM	446564-01	1	1	1	1	-					
		PVC FILM	4A2530-01					1					
14	LABEL – R404A	PES FILM	4A0960-01	1	1	1	1	1					
15	RATING LABEL	PES FILM	4A1809-01	1	1	1	1	-					
		PES FILM	4A2406-01					1					
16	LABEL (B) – CONTROL BOARD	-	4A2528-01					1					

HA

KM-280MAF, MWF, MAH, MWH

F. PUMP MOTOR ASSEMBLY

J-0, J-1, J-2, K-0, L-0

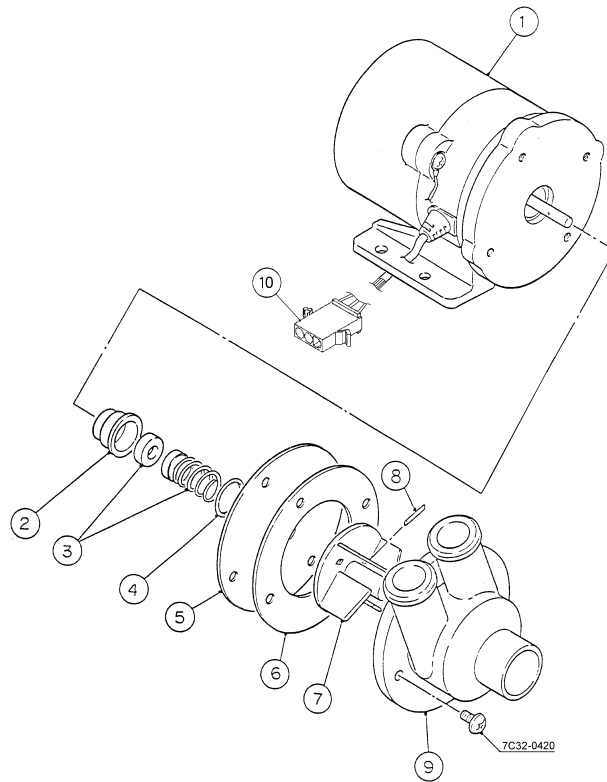

KM-280MAH, MWH

F. PUMP MOTOR ASSEMBLY

L-0

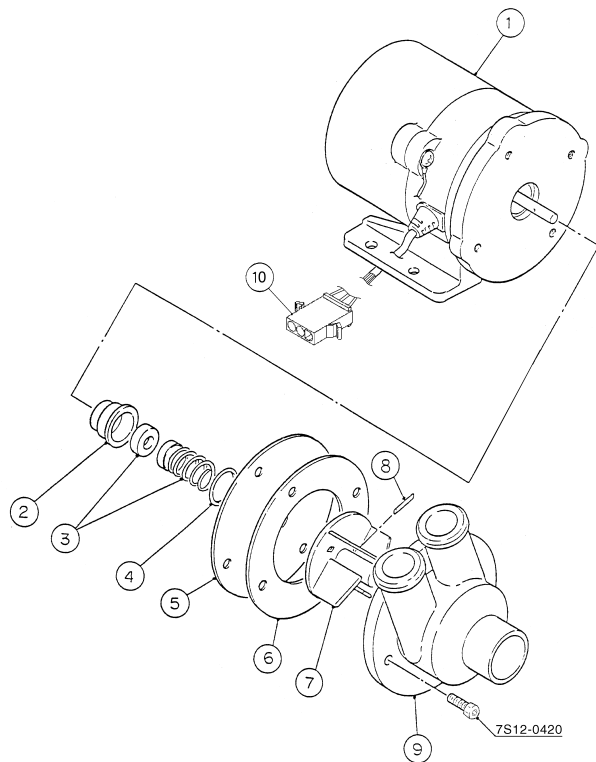

MODEL: KM-280MAF, MWF, MAH, MWH TITLE: F. PUMP MOTOR ASSEMBLY												
INDEX NO.	DESCRIPTION	MATERIAL OR MODEL NUMBER	PART NUMBER	REQUIRED NUMBER								
				KM-280MAF			KM-280MAH					
				KM-280MWF			KM-280MWH					
				J-0	J-2	K-0	L-0	L-0				
				J-1								
1	PUMP MOTOR	AP-TA4(H) 120V	2U0095-01	1	1	1	1	1				
2	RETAINER	SS	418584-01	1	1	1	1	1				
3	MECHANICAL SEAL (B)	H5-PS9, 5	415817-01	1	1	1	1	1				
4	"O" RING	1AP18	7611-P018	1	1	1	1	1				
5	PLATE – PUMP	SS	403013-01	1	1	1	1	1				
6	PUMP GASKET	NR	403014-01	1	1	1	1	1				
7	IMPELLER	ABS	3A0990-01	1	1	1	1	1				
8	PIN	SS	414102-01	1	1	1	1	1				
9	PUMP HOUSING	ABS	3A0989-01	1	1	1	1	1				
	TRUSS HEAD SCREW	4X20, SS	7C32-0420	4	4	4	4	x4				
	HEX SOCKET HEAD CAP SCREW	4X20, SS	7S12-0420					o4				
10	PLUG HOUSING	-	412832-06	1	1	1	1	1				

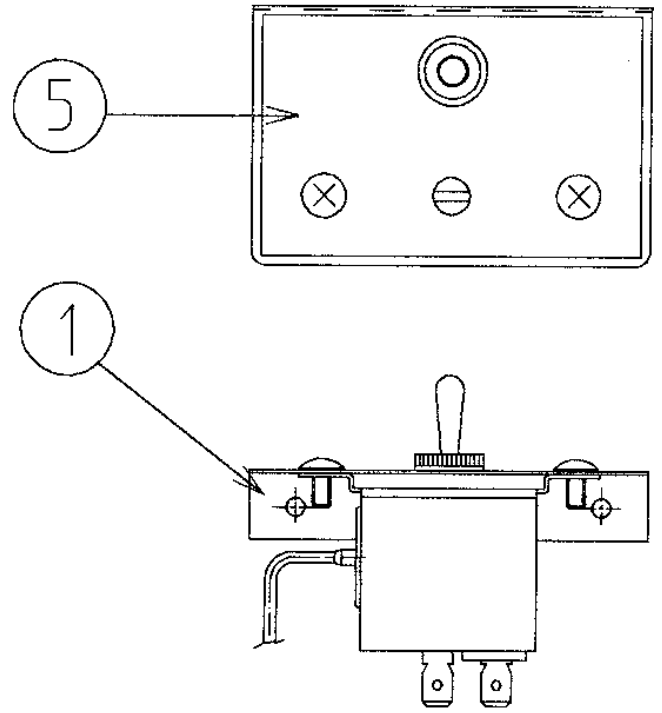
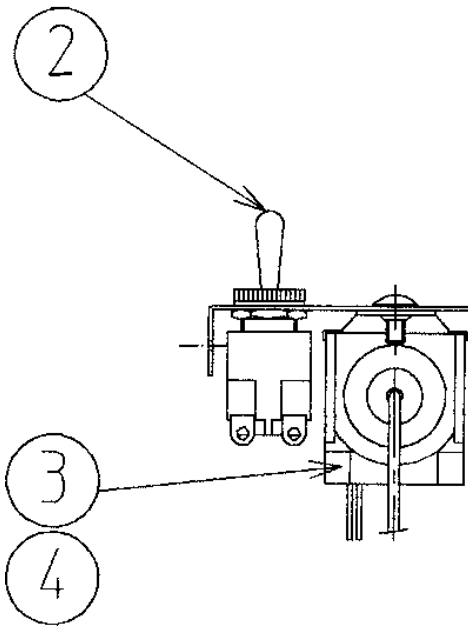

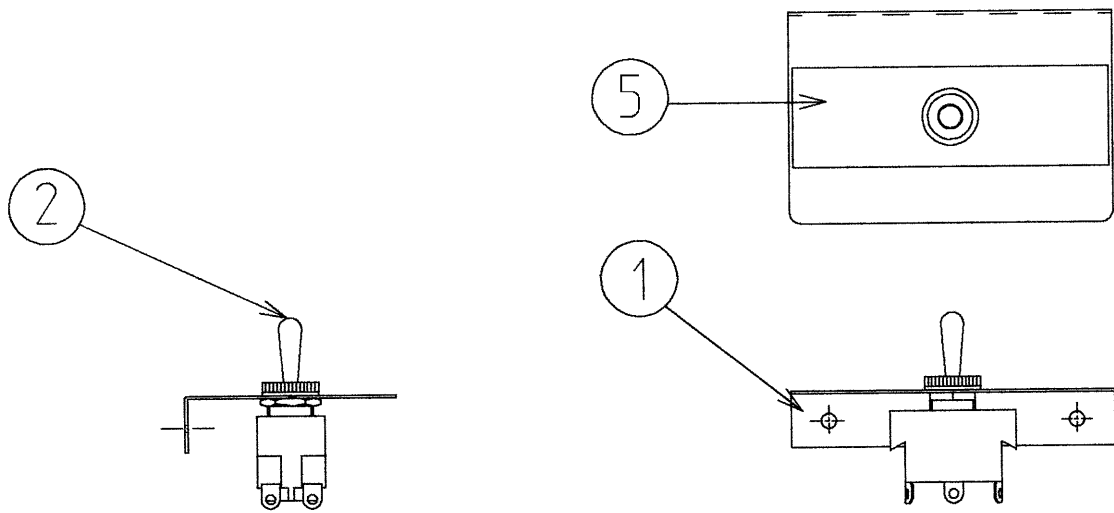

HA

MODEL: KM-280MAF, MWF, MAH, MWH TITLE: G. CONTROL ASSEMBLY											
INDEX NO.	DESCRIPTION	MATERIAL OR MODEL NUMBER	PART NUMBER	REQUIRED NUMBER							
				KM-280MAF				KM-280MAH			
				KM-280MWF				KM-280MWH			
				J-0	J-2	K-0	L-0	L-0			
1	CONTROL BOX (C)	-	446559-01	1	1	1	1	-			
		-	4A2517-01					1			
2	TOGGLE SWITCH	7K63K6	443119-01	1	1	1	1	1			
3	THERMOSTAT	A30-3815-00	4A0824-01	1	1	1	1	-			
4	TRUSS HEAD SCREW	4X8	7C31-0408	2	2	2	2	-			
5	CONTROL LABEL	-	446542-01	1	1	1	1	-			
		-	4A2509-01					1			

HA

KM-280MAF, MWF, MAH, MWH

H. ACCESSORIES

J-0, J-1, J-2, K-0, L-0

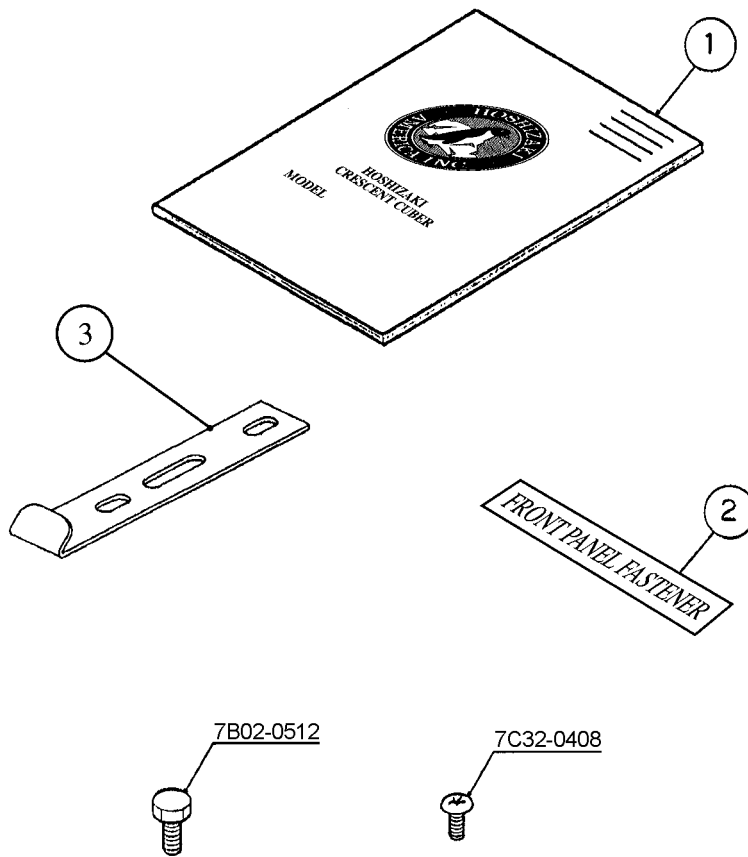

MODEL: KM-280MAF, MWF, MAH, MWH TITLE: H. ACCESSORIES													
INDEX NO.	DESCRIPTION	MATERIAL OR MODEL NUMBER	PART NUMBER	REQUIRED NUMBER									
				KM-280MAF KM-280MWF			KM-280MAH KM-280MWH						
				J-0 J-1	J-2	K-0	L-0	L-0					
1	INSTRUCTION MANUAL	PAPER	91A1NA10A	1	1	1	1	-					
		PAPER	91A1NE10A					1					
2	LABEL – FASTENER	PAPER	427122-01	1	1	1	1	1					
3	UNIVERSAL BRACE	GS	4A0363-01	2	2	2	2	2					
	HEX HEAD BOLT	5X12, SS	7B02-0512	4	4	4	4	4					
	TRUSS HEAD SCREW	4X8, SS	7C32-0408	1	1	1	1	1					