



Lancer Corp.  
6655 Lancer Blvd.  
San Antonio, Texas 78219

800-729-1500  
Technical Support/Warranty: 800-729-1550  
custserv@lancercorp.com  
lancercorp.com



Manual PN: 28-0777

JULY, 2009

**FOR QUALIFIED INSTALLER ONLY**

### ABOUT THIS MANUAL

This booklet is an integral and essential part of the product and should be handed over to the operator after the installation and preserved for any further consultation that may be necessary. Please read carefully the guidelines and warnings contained herein as they are intended to provide the user with essential information for the continued safe use and maintenance of the product. In addition, it provides GUIDANCE ONLY to the user on the correct services and site location of the unit.

The installation and relocation, if necessary, of this product must be carried out by qualified personnel with up-to-date safety and hygiene knowledge and practical experience, in accordance with current regulations.

## TABLE OF CONTENTS

<b>SPECIFICATIONS.....</b>	<b>3</b>
<b>PRE-INSTALLATION CHECKLIST.....</b>	<b>4</b>
<b>WARNINGS/CAUTIONS.....</b>	<b>5-8</b>
<b>1. INSTALLATION.....</b>	<b>9</b>
1.1 UNPACKING.....	9
1.2 SELECTING A COUNTER LOCATION.....	9
1.3 WATER SUPPLY.....	9
1.4 ELECTRICAL SUPPLY.....	9
1.5 INSTALLATION OF THE UNIT.....	9
1.6 CONNECTION OF THE UNIT.....	10
1.7 START UP.....	10
<b>2. MVU OPERATION.....</b>	<b>11</b>
2.1 PROGRAMMING THE MVU.....	11
2.2 SET MVU FOR FLAVOR SHOTS.....	12
2.3 FLOW RATE CHECK.....	13
2.4 RATIO PROCESS.....	14
2.5 PORTION CONTROL PROGRAMMING (MVU) (NO TOP-OFF).....	14-15
2.6 PORTION CONTROL PROGRAMMING WITH TOP-OFF (MVU).....	15
2.7 SHOT SIZE PROGRAMMING.....	16-17
<b>3. RECOMMENDED SERVICE AND MAINTENANCE.....</b>	<b>18</b>
3.1 SCHEDULED.....	18
3.2 CLEANING AND SANITIZING SYSTEMS.....	18
3.3 CLEANING AND SANITIZING BAG-IN-BOX (BIB) SYSTEMS.....	19
3.4 NOZZLES.....	19
<b>4. TROUBLESHOOTING.....</b>	<b>20</b>
<b>5. DISPENSER DISPOSAL.....</b>	<b>20</b>
<b>6. ILLUSTRATIONS AND PART LISTINGS.....</b>	<b>22</b>
6.1 MVU TOWER ASSEMBLY.....	22-23

# MVU TOWER SPECIFICATIONS

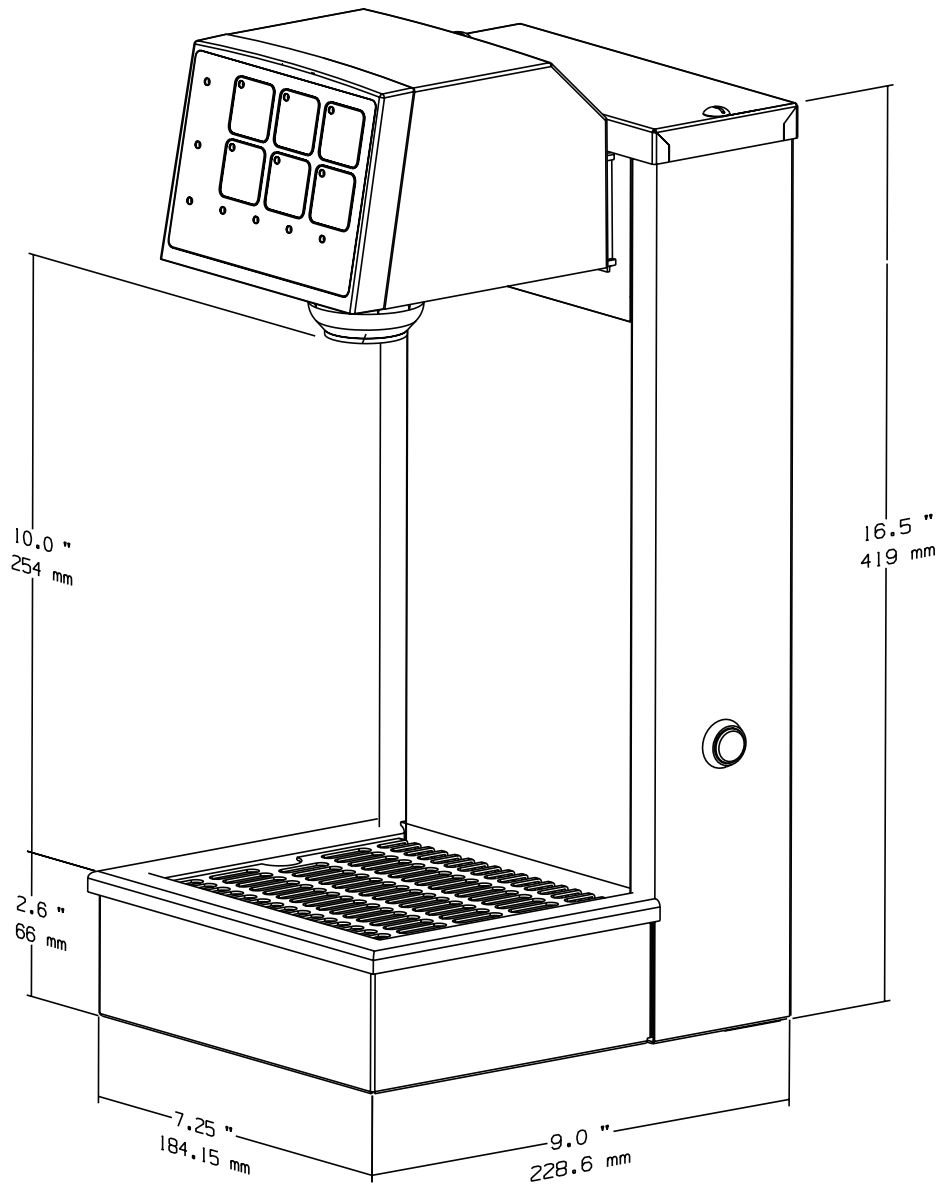

<p><b>DIMENSIONS</b>  <b>Width:</b> 7.25 inches (184.15 mm)  <b>Depth:</b> 9 inches (228.6 mm)  <b>Height:</b> 16.5 inches (419 mm)</p> <p><b>ELECTRICAL</b>                  24 VAC/ 60 Hz</p>	<p><b>FITTINGS</b>  <b>Plain water inlet:</b> 3/8" barb  <b>Brand syrup inlets:</b> 3/8" barb</p> <p><b>WEIGHT</b>  <b>Shipping:</b> 15 lbs (7 kg)</p>	<p><b>PLAIN WATER SUPPLY</b>  <b>Min flowing pressure:</b>                  20 PSI (0.138 MPA)  <b>Max flowing pressure:</b>                  50 PSI (0.345 MPA)</p> <p><b>CARBON DIOXIDE (CO<sub>2</sub>)</b>  <b>Min pressure:</b>                  90 PSIG (0.621 MPA)  <b>Max pressure:</b>                  110 PSIG (0.758 MPA)</p>
---	--	---

This unit emits a sound pressure level below 70 dB

# PRE-INSTALLATION CHECKLIST

## BEFORE GETTING STARTED

Each unit is tested under operating conditions and is thoroughly inspected before shipment. At the time of shipment, the carrier accepts responsibility for the unit. Upon receiving the unit, carefully inspect the carton for visible damage. If damage exists, have the carrier note the damage on the freight bill and file a claim with carrier. Responsibility for damage to the dispenser lies with the carrier.

TOOLS & ACCESSORIES	
<input type="checkbox"/> CO2 Regulator Set	<input type="checkbox"/> Beverage Tubing
<input type="checkbox"/> CO2 Supply	<input type="checkbox"/> Water Booster (if necessary)
<input type="checkbox"/> Remote System	<input type="checkbox"/> Oetiker Clamps/Fittings
<input type="checkbox"/> Wrenches	<input type="checkbox"/> Slotted Screwdriver
<input type="checkbox"/> Tubing Cutters	<input type="checkbox"/> Drill

BIB SYSTEM	
<input type="checkbox"/> BIB Rack	<input type="checkbox"/> BIB Regulator Set
<input type="checkbox"/> BIB Connectors - verify correct amount for syrup lineup	
<input type="checkbox"/> BIB Syrup Boxes	<input type="checkbox"/> Remote Cooling/Carbonation System

CONSIDER LOCATION OF THE FOLLOWING PRIOR TO INSTALL	
<input type="checkbox"/> Water supply lines	<input type="checkbox"/> Is the countertop at least 1 inch thick?
<input type="checkbox"/> Grounded electrical outlet.	<input type="checkbox"/> Drain
<input type="checkbox"/> Is there enough space to install the dispenser and the junction box?	



## WARNING/ADVERTENCIA/AVERTISSEMENT



⚠ The dispenser is for indoor use only. This unit is not a toy. Children should not be supervised not to play with appliance. It should not be used by children or infirm persons without supervision. This appliance is not intended for use by persons (including children) with reduced physical, sensory or mental capabilities, or lack of experience and knowledge, unless they have been given supervision or instruction concerning use of the appliance by a person responsible for their safety. Cleaning and user maintenance shall not be performed by children without supervision. This unit is not designed to dispense dairy products. The min/max ambient operating temperature for the dispenser is 40°F to 90°F (4°C to 32°C). Do not operate unit below minimum ambient operation conditions. Should freezing occur, cease operation of the unit and contact authorized service technician. Service, cleaning and sanitizing should be accomplished only by trained personnel. Applicable safety precautions must be observed. Instruction w!arnings on the product being used must be followed.

⚠ El dispensador sólo debe usarse en interiores. Esta unidad no es un juguete. Los niños deben ser supervisados para no jugar con aparato. No la deben usar niños ni personas discapacitadas sin supervisión. Esta unidad no está destinada al uso por parte de personas (incluso niños) con capacidad física, sensorial o mental reducida, o sin experiencia y conocimientos suficientes, a menos que una persona responsable de su seguridad les haya dado supervisión o capacitación en el uso de la unidad. Limpieza y mantenimiento de usuario no deberá ser realizada por los niños sin supervisión. Esta unidad no ha sido diseñada para suministrar productos lácteos. La temperatura ambiente operativa mínima / máxima para el dispensador es de 40°F a 90°F (4°C a 32°C). No opere la unidad debajo de las condiciones de funcionamiento ambientales mínimos. En caso de congelación se produce, cesar la operación de la unidad y el contacto técnico de servicio autorizado. Servicio de limpieza y desinfección deben llevarse a cabo solamente por personal capacitado. Es necesario tomar medidas de seguridad aplicables. Advertencias de las instrucciones sobre el producto utilizado se deben seguir.

⚠ Le distributeur est destiné à un usage à l'intérieur seulement. Cet appareil n'est pas un jouet. Les enfants doivent être surveillés afin de ne pas jouer avec l'appareil. Il ne devrait pas être utilisé par des enfants ou des personnes infirmes sans surveillance. Cet appareil n'est pas destiné à un usage par des personnes (y compris les enfants) ayant des capacités physiques, sensorielles ou mentales réduites, ou manquant d'expérience et de connaissances, à moins qu'elles obtiennent de la surveillance ou des instructions au sujet de l'utilisation de l'appareil de la part d'une personne chargée de leur sécurité. Nettoyage et entretien de l'utilisateur ne doivent pas être effectués par des enfants sans surveillance. Cet appareil n'est pas conçu pour distribuer des produits laitiers. La température de service ambiante minimum/maximum pour le distributeur est de 40°F à 90°F (4°C à 32°C). Ne pas utiliser l'appareil dans des conditions de performance environnementale minimale. En cas de gel, cesser l'exploitation de l'unité et contactez un technicien agréé. Nettoyage et désinfection doivent être effectuées uniquement par du personnel qualifié. Vous devez prendre des mesures de sécurité. Avertissements instructions sur le produit utilisé doivent être respectées.



## DISPENSER INSTALLATION HIGHLIGHTS



### ***This unit has been factory sanitized per Lancer specifications.***

Listed below are six critical elements which will aid in a successful installation.

1. Fill water bath until water overflows from tank overflow tube.
2. The carbonator pump motor must be disconnected from the power supply prior to connection to water supply for initial build up of ice bank. Failure to do so will result in automatic shut off of carbonator (see item 6 below) or damage to the pump.
3. If this dispenser is installed in an area that is susceptible to  $\pm 10\%$  variation of the nominal line voltage, consider installing a surge protector or similar protection device.
4. There is a five (5) minute delay which prevents the compressor and condenser fan from starting until the delay has lapsed. If electrical current is interrupted, there is always a five (5) minute delay before the compressor starts.
5. Supply Water Pressure: Minimum - 20 PSI (0.138 MPA); Maximum - 50 PSI (0.345 MPA); If pressure is over 50 PSIG (0.345 MPA), a water pressure regulator must be used.
6. On units with the built in water regulator, the regulator must be removed if inlet water pressure is less than 20 PSIG. (0.138 MPA)



## PUNTOS IMPORTANTES EN LA UNIDAD DISPENSADORA



### ***Esta unidad ha sido saneada en fabrica por las especificaciones de Lancer.***

A continuacion se relacionan 6 puntos importantes para una correcta instalacion.

1. Llene el bano-Maria hasta que el agua se desborde sobre el tubo que controla la derrama del tanque.
2. El motor de la bomba del carbonatador debe desconectarse electricamente antes de conectar el suministro de agua para la formacion inicial del banco de hielo. De no hacerse esto resultaria en un bloqueo automatico del carbonatador (ver abajo el punto 6) o en danos a la bomba.
3. Si la unidad va a ser instalada en un area en la que puedan darse variaciones de voltage de + 6 - 10% de su valor nominal, se debe considerar la conveniencia de instalar un estabilizador de corriente o sistema de proteccion similar.
4. Hay una demora de 5 minutos que evita que el compresor y el abanico del condensador arranquen hasta pasado ese tiempo. Si hay algun corte en la corriente electrica siempre se producira esa demora de 5 minutos antes de arrancar el compresor.
5. Presión de suministro del agua de red: Minimo 20 PSI (0.138 MPA); Maximo 50 PSI (0.345 MPA). En unidades sin regulador de presión incorporado, si la presión del agua es superior a 50 PSIG (0.345 MPA) se debe usar un regulador de presión.
6. En unidades con regulador de presión incorporado, el regulador debe ser eliminado cuando la presión de entrada de agua sea inferior a 20 PSIG (0.138 MPA).



## REGLES DE SECURITE POUR L'INSTALLATION DU DISTRIBUTEUR DE SODAS



### ***La propriété de cet ensemble est assurée à l'usine suivant les spécifications émises par Lancer .***

Il est essentiel de respecter les 6 points suivants pour l'installation de l'appareil:

1. Remplir le bain-Maire jusqu'à ce que l'eau déborde par le tuyau de trop-plein du réservoir.
2. Le moteur de la pompe du carbonateur doit être débranché de l'alimentation électrique avant l'arrivée de l'eau pour la formation initiale de la glace. Oublier ou négliger cette opération provoquera l'arrêt automatique du carbonateur (voir le point 6 ci-dessous) ou causera des dommages à la pompe.
3. Si le distributeur est installé dans une zone où la tension électrique nominale est susceptible de variations de (+) 10%, il est conseillé d'installer un appareil de protection contre les sautes de courant.
4. Un délai de 5 minutes empêche le compresseur et la ventilation du condenseur de se mettre en marche avant que ce laps de temps ne se soit écoulé. Lorsque le courant électrique est interrompu, il y a toujours un délai de 5 minutes avant que le presseur ne se mette en.
5. Pression de l'eau: Minimum 20 PSI (0.138 MPA); Maximo 50 PSI (0.345 MPA). Sur les unités qui n'ont pas de régulateur de pression d'eau incorporé, si la pression d'H<sub>2</sub>O est supérieure à 50 PSIG (0.345 MPA), un régulateur de pression d'eau doit être utilisé.
6. Sur les unités avec régulateur d'eau incorporé, le régulateur doit être enlevé si la pression d'arrivée est inférieure à 20 PSIG (0.138 MPA)



## ELECTRICAL WARNING/ADVERTENCIA ELÉCTRICA/ AVERTISSEMENT ÉLECTRIQUE



⚠ Check the dispenser serial number plate for correct electrical requirements of unit. Do not plug into a wall electrical outlet unless the current shown on the serial number plate agrees with local current available. Follow all local electrical codes when making connections. Each dispenser must have a separate electrical circuit. Do not use extension cords with this unit. Do not 'gang' together with other electrical devices on the same outlet. The keyswitch does not disable the line voltage to the transformer primary. Always disconnect electrical power to the unit to prevent personal injury before attempting any internal maintenance. The resettable breaker switch should not be used as a substitute for unplugging the dispenser from the power source to service the unit. Only qualified personnel should service internal components of electrical control housing. Make sure that all water lines are tight and units are dry before making any electrical connections!

⚠ Verifique la placa con el número de serie del dispensador, donde encontrará los requisitos eléctricos correctos de la unidad. No enchufe la unidad en un tomacorriente de pared a menos que la corriente indicada en la placa con el número de serie concuerde con la corriente local disponible. Al hacer las conexiones, respete todos los códigos eléctricos locales. Cada dispensador debe tener un circuito eléctrico independiente. No use extensiones con esta unidad. No la conecte junto con otros dispositivos eléctricos al mismo tomacorriente. El interruptor de llave no corta el voltaje de línea al transformador primario desconecte siempre la alimentación eléctrica a la unidad para evitar lesiones personales antes de tratar de realizar tareas de mantenimiento. El disyuntor de sobrecarga resettable no se debe usar como sustituto para desenchufar el dispensador de la fuente de alimentación para realizar tareas de servicio de la unidad. El servicio de los componentes internos de la caja de control eléctrico debe confiarse exclusivamente a personal calificado. Asegúrese de que todas las líneas de agua estén ajustadas y las unidades estén secas antes de hacer conexiones eléctricas.

⚠ Examinez la plaque de numéro de série du distributeur pour connaître les bonnes exigences en matière d'électricité pour l'appareil. Ne le branchez pas à une prise électrique murale à moins que le courant indiqué sur la plaque de numéro de série corresponde au courant local disponible. Respectez tous les codes électriques locaux lorsque vous faites des connexions. Chaque distributrice doit avoir un circuit électrique séparé. N'utilisez pas de cordons prolongateurs avec cet appareil. Ne pas le brancher avec d'autres appareils électriques sur la même prise. L'interrupteur à clé ne coupe pas la tension secteur au transformateur primaire. Débranchez toujours le courant électrique à l'appareil, afin de prévenir des blessures, avant de faire un entretien interne quelconque. Le disjoncteur réarmable ne devrait pas être utilisé au lieu de débrancher le distributeur de la source d'alimentation en électricité pour faire de l'entretien/une réparation de l'appareil. Seul le personnel qualifié devrait faire l'entretien/la réparation des composants internes dans le logement des commandes électriques. Assurez-vous que toutes les conduites d'eau sont étanches et que les appareils sont secs avant de faire des connexions électriques!



## CO<sub>2</sub>/CARBON DIOXIDE /EI ANHÍDRIDO CARBÓNICO/ DIOXYDE DE CARBONE



⚠ Carbon Dioxide (CO<sub>2</sub>) is a colorless, noncombustible gas with a light pungent odor. High percentages of CO<sub>2</sub> may displace oxygen in the blood. Prolonged exposure to CO<sub>2</sub> can be harmful. Personnel exposed to high concentrations of CO<sub>2</sub> gas will experience tremors which are followed by a loss of consciousness and suffocation. If a CO<sub>2</sub> gas leak is suspected, immediately ventilate the contaminated area before attempting to repair the leak. Strict attention must be observed in the prevention of CO<sub>2</sub> gas leaks in the entire CO<sub>2</sub> and soft drink system.

⚠ El anhídrido carbónico (CO<sub>2</sub>) es un gas incoloro, no combustible, con un olor pungente ligero. Altos porcentajes de CO<sub>2</sub> en la sangre pueden desplazar el oxígeno en la sangre. La exposición prolongada al CO<sub>2</sub> puede ser nociva. El personal expuesto a concentraciones altas de CO<sub>2</sub> sufre temblores seguidos de la pérdida de la consciencia y sofocación. Si se sospecha que existe una pérdida de CO<sub>2</sub>, ventile el área contaminada antes de tratar de reparar la pérdida. Hay que prestar suma atención para evitar pérdidas de CO<sub>2</sub> en todo el sistema de CO<sub>2</sub> y de bebidas gaseosas.

⚠ Le dioxyde de carbone (CO<sub>2</sub>) est plus lourd que l'air et déplace l'oxygène. Le CO<sub>2</sub> est un gaz incolore et incombustible, ayant une odeur un peu âcre. Des concentrations fortes de CO<sub>2</sub> peuvent déplacer l'oxygène dans le sang. Une exposition prolongée au CO<sub>2</sub> peut être nocive. Le personnel exposé à de fortes concentrations de CO<sub>2</sub> gazeux éprouvera des tremblements, suivis rapidement d'une perte de conscience et de suffocation. On doit faire très attention de prévenir les fuites de CO<sub>2</sub> gazeux dans le système entier de CO<sub>2</sub> et de boisson gazeuse. Si on suspecte qu'il y a une fuite de CO<sub>2</sub> gazeux, aérez le secteur contaminé immédiatement avant d'essayer de réparer la fuite.



## WATER NOTICE/AGUA AVISO/ PRÉAVIS DE L'EAU



⚠ Provide an adequate potable water supply. Water pipe connections and fixtures directly connected to a potable water supply must be sized, installed, and maintained according to federal, state, and local laws. The water supply line must be at least a 3/8 inches (9.525 mm) pipe with a minimum of 20 PSI (0.138 MPA) line pressure, but not exceeding a maximum of 50 PSI (0.345 MPA). Water pressure exceeding 50 PSI (0.345 MPA) must be reduced to 50 PSI (0.345 MPA) with the provided pressure regulator. Use a filter in the water line to avoid equipment damage and beverage off-taste. Check the water filter periodically, as required by local conditions. The water supply must be protected by means of an air gap, a backflow prevention device (located upstream of the CO2 injection system) or another approved method to comply with NSF standards. A leaking inlet water check valve will allow carbonated water to flow back through the pump when it is shut off and contaminate the water supply. Ensure the backflow prevention device complies with ASSE and local standards. It is the responsibility of the installer to ensure compliance.

⚠ Proporcione un suministro adecuado de agua potable. La línea de suministro de agua debe ser de una tubería de por lo menos 3/8 pulgadas (9.525 mm) con una presión de línea mínima de 20 PSI (0.138 MPA) , pero sin superar el máximo de 50 PSI (0.345 MPA). La presión de agua que supere los 50 PSI (0.345 MPA) se debe reducir a 50 PSI (0.345 MPA) con un regulador de presión. Use un filtro en la línea de agua para evitar daños al equipo y cierto sabor raro en las bebidas. Verifique periódicamente el filtro de agua de acuerdo con las condiciones imperantes. El suministro de agua debe estar protegido por una separación de aire, un dispositivo de prevención del contraflujo (situado antes del sistema de inyección de CO2) u otro método aprobado para cumplir las normas NSF. Si la válvula de retención de entrada de agua tuviera pérdidas, permitiría el contraflujo del agua carbonatada a través de la bomba cuando se la detiene y contaminaría el suministro de agua. Asegúrese de que el dispositivo de prevención del contraflujo cumpla con las normas locales y de ASSE. Es responsabilidad del instalador cumplir con estos requisitos.

⚠ Fournissez une alimentation en eau potable adéquate. Les connexions et les dispositifs de conduite d'eau connectés directement à une alimentation en eau potable doivent être calibrés, installés et maintenus selon les lois fédérales, provinciales et locales. La conduite d'alimentation en eau doit être un tuyau d'au moins 3/8 pouces (9.525 millimètres) avec une pression de ligne minimum de 20 LPC (0.138 MPA) , mais ne doit pas dépasser un maximum de 50 LPC (0.345 MPA). Une pression d'eau de plus de 50 LPC (0.345 MPA) doit être réduite à 50 LPC (0.345 MPA) avec le régu- lateur de pression fourni. Utilisez un filtre dans la conduite d'eau pour éviter des dommages à l'équipement et un goût des boissons qui n'est pas juste. Vérifiez le filtre à eau périodiquement, selon les exigences des conditions locales. L'alimentation en eau doit être protégée au moyen d'un intervalle d'air, un disconnecteur hydraulique (situé en amont du système d'injection de CO2) ou une autre méthode approuvée pour se conformer aux normes de la NSF. Un clapet antiretour pour l'eau entrante qui fuie permettra à l'eau gazeuse de repasser par la pompe quand elle est fermée et de contaminer l'alimentation en eau. Assurez-vous que le disjoncteur hydraulique soit conforme aux normes de l'ASSE et locales. L'installateur est responsable d'assurer la conformité.

## 1. INSTALLATION

### 1.1 UNPACKING

- A. The Lancer dispenser is shipped in a corrugated shipping carton.
- B. Remove dispenser from corrugated shipping carton.
- C. Inspect unit and parts for concealed damage. If damage exists, notify delivering carrier and file claim against same.

### 1.2 SELECTING A COUNTER LOCATION

- A. Select a counter location which is close to a properly grounded electrical outlet, and a water supply that meets the requirements specified below.

### 1.3 WATER SUPPLY

	<b>CAUTION</b> FAILURE TO LIMIT WATER PRESSURE TO 50 PSI (0.345 MPA) WILL RESULT IN IMPROPER PERFORMANCE OF THE DISPENSER.
	<b>PRECAUCIÓN</b> FALTA DE LIMITAR LA PRESIÓN DE AGUA PARA 50 PSI (0.345 MPA) DARÁ LUGAR A INADECUADO EJECUCIÓN DEL DISTRIBUIDOR.
	<b>ATTENTION</b> DÉFAUT DE LIMITER LA PRESSION DE L'EAU A 50 LPC (0,345 MPA) ENTRAÎNERA MAUVAISE PERFORMANCE DU DISTRIBUTEUR.

- A. An adequate potable water supply must be provided. The water supply line must be at least a 3/8 inch (9.525 mm) pipe with a minimum of 20 PSI (0.138 MPA) line pressure, but not exceeding a maximum of 50 PSI (0.345 MPA). Water pressure exceeding 50 PSI (0.345 MPA) must be reduced to 50 PSI (0.345 MPA) with a pressure regulator.

### 1.4 ELECTRICAL SUPPLY

	<b>GROUNDING WARNING</b> THE DISPENSER MUST BE PROPERLY ELECTRICALLY GROUNDED TO AVOID SERIOUS INJURY OR FATAL ELECTRICAL SHOCK. THE POWER CORD HAS A THREE-PRONG GROUNDED PLUG. IF A THREE-HOLE GROUNDED ELECTRICAL OUTLET IS NOT AVAILABLE, USE AN APPROVED METHOD TO GROUND THE UNIT. FOLLOW ALL LOCAL ELECTRICAL CODES WHEN MAKING CONNECTIONS. EACH DISPENSER MUST HAVE A SEPARATE ELECTRICAL CIRCUIT. DO NOT USE EXTENSION CORDS. DO NOT CONNECT MULTIPLE ELECTRICAL DEVICES ON THE SAME OUTLET.
	<b>ADVERTENCIA, PUESTA A TIERRA</b> ES NECESARIO PONER A TIERRA ELÉCTRICAMENTE EL DISPENSADOR PARA EVITAR LESIONES GRAVES E INCLUSO ELECTROCHOQUES FATALES. EL CABLE DE ALIMENTACIÓN TIENE UN ENCHUFE PUESTO A TIERRA DE 3 CLAVIJAS. SI NO SE DISPONE DE UN TOMA ELÉCTRICO CONECTADO A TIERRA DE TRES AGUJEROS, USE UN MÉTODO APROBADO PARA PONER A TIERRA LA UNIDAD. AL HACER LAS CONEXIONES, RESPETE TODOS LOS CÓDIGOS ELÉCTRICOS LOCALES. CADA DISPENSADOR DEBE TENER UN CIRCUITO ELÉCTRICO INDEPENDIENTE. NO USE CABLES DE EXTENSIÓN. NO CONECTE VARIOS DISPOSITIVOS ELÉCTRICOS AL MISMO TOMACORRIENTE.
	<b>EXIGENCES DE MISE À LA TERRE</b> LA DISTRIBUTRICE DOIT ÊTRE MISE À LA TERRE ÉLECTRIQUEMENT CORRECTEMENT POUR ÉVITER DES BLESSURES GRAVES OU UNE DÉCHARGE ÉLECTRIQUE MORTELLE. LE CORDON D'ALIMENTATION A UNE FICHE À TROIS BRANCHES MISE À LA TERRE. SI AUCUNE PRISE DE COURANT ÉLECTRIQUE À TROIS TROUS N'EST DISPONIBLE, UTILISEZ UNE MÉTHODE APPROUVÉE POUR METTRE L'UNITÉ À LA TERRE. RESPECTEZ TOUS LES CODES ÉLECTRIQUES LOCAUX LORSQUE VOUS FAITES DES CONNEXIONS. CHAQUE DISTRIBUTRICE DOIT AVOIR UN CIRCUIT ÉLECTRIQUE SÉPARÉ. N'UTILISEZ PAS DE CORDONS PROLONGATEURS. NE BRANCHEZ PAS PLUSIEURS APPAREILS ÉLECTRIQUES À LA MÊME PRISE DE COURANT.

- A. A standard 20 AMP, 110 VAC, 60Hz single phase electrical power outlet with a ground connector should be provided for the operation of the unit.

### 1.5 INSTALLATION OF THE UNIT

- A. Inspect the counter location where the unit is to be installed.
- B. Verify that the unit will fit in the desired location.

**NOTE:** See counter cutout template which is included in the shipping carton.

- C. After the counter cutout is complete, the unit may be secured to the counter.

## 1.6 CONNECTION OF THE UNIT

- A. Position the CO2 gas tank in the desired location. Assemble high pressure regulator to CO2 gas tank and run jumper line to low pressure regulator.
- B. Attach the CO2 gas line to the carbonator by attaching the line from the high pressure regulator to the single check valve marked "gas" on top of the carbonator tank. The setting of the high pressure CO2 gas regulator should be 90 PSI (0.621 MPA) to 110 PSI (0.758 MPA).



**WARNING** DO NOT TURN ON THE CO2 SUPPLY AT THIS TIME.

**ADVERTENCIA** NO CONECTE TODAVÍA LA ALIMENTACIÓN DE CO2.

**AVERTISSEMENT** N'OUVREZ PAS L'ALIMENTATION EN CO2 À CE MOMENT.

- C. Position the syrup pumps in the desired location. Attach the CO2 gas lines leading from the low pressure regulator to these pumps.
- D. Connect syrup lines from pumps to the appropriate inlets on the unit behind the splash plate. The syrup inlets are identified.
- E. Mount the water filter assembly (if used) and water regulator in a convenient location.
- F. Connect water inlet line to water regulator, to water filter, and then to the water inlet of the carbonator pump on the carbonator.
- G. Provide a suitable drain in the plumbing system and attach the gray tube to it. The drip pan drain outlet is located on the bottom of the drip tray. Drain tubing is supplied with the unit.
- H. Plug in the transformer box to a standard 20 AMP, 110 VAC single phase outlet. The unit will internally convert the 110 VAC to 24 VAC.

## 1.7 START UP

- A. After all connections to water, CO2 gas, electrical power, and syrup pumps are made, check for leaks.
- B. Be sure bag-in-box contains syrup.



**CAUTION** DO NOT OPERATE CARBONATOR PUMP WITH WATER SUPPLY SHUT OFF.

**PRECAUCIÓN** NO HAGA FUNCIONAR LA BOMBA CARBONATADOR CON SUMINISTRO DE AGUA CIERRE.

**ATTENTION** NE PAS FAIRE FONCTIONNER LA POMPE DE CARBONATEUR L'APPROVISIONNEMENT EN EAU COUPÉE.

- C. Turn on water; open the pressure relief valve on the carbonator tank by lifting the wire ring or flipping lever, and hold it open until water flows from the relief valve. Close the relief valve and turn on the CO2 gas and electrical power in that order.
- D. To fill all lines with water, cycle the carbonator several times by operating the dispensing valves.
  1. A low pressure gas regulator controls the flow of syrup to each dispensing valve. For proper operation of the valves, the pressure regulator should be set so that 65 PSI is at the shut-off of the valve.

## 2. MVU OPERATION

**2.1 PROGRAMMING THE MVU:** Set the MVU buttons as Carbonated, Non-Carbonated, or Flavor Shot Only. The MVU can be programmed to serve soda or plain water beverages as well as a flavor shot from each of the beverage positions on the valve.

To enter the programming mode on the MVU and assign water type to each individual brand

- A. Press both A and C brand buttons at the same time on the MVU panel for five seconds.
1. The “Pour/Cancel” LED will illuminate. The “SHOT” LED will blink one time.
  2. Brands that are enabled for drinks will have illuminated LED’s:  
Lights on = non-carb  
Lights flashing = carb  
Lights off = no water (deactivated unless set for shot)

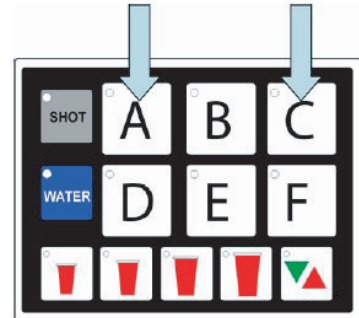

- B. Press a Brand button to change that beverage from “water off” to “plain water on”.
1. LED will illuminate and stay on for non-carb beverages.
- C. Press the same brand button again to switch from non-carb to carb.
1. Press the button one more time to turn the water off for that valve (if position is used for a flavor shot only).
- D. Repeat this process for each brand.
- E. Press the Pour/Cancel button to lock the changes in place and exit the programming mode.

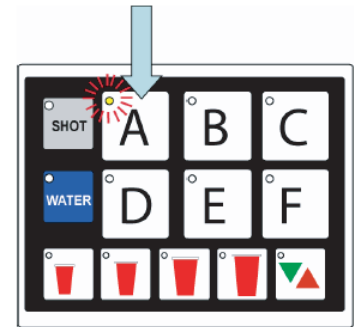

**NOTE:** The Program will save automatically in 60 seconds if no additional changes are made in that time frame; however, you can exit any time within the 60 second window by pressing Pour/Cancel. The changes you’ve made will be saved.

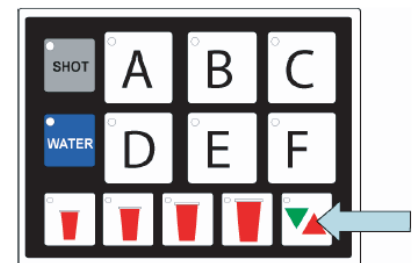
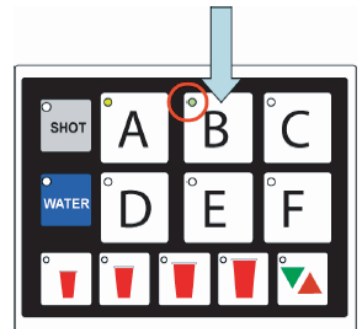

## 2.2 SET MVU FOR FLAVOR SHOTS

- A. Press both A and C brand buttons (at the same time) on the MVU panel for five seconds to get into programming mode.
- B. Press the “Shot” button.
  1. The “Shot” button will illuminate.
  2. Brands enabled for shots will be illuminated.
- C. Press the “Brand” button to turn the shot mode for that brand on or off.
  1. The shot mode is “ON” in the illustration.
- D. Press “Shot” again to return to “Drink Type Selection”
- E. Press the Pour/Cancel button to lock the changes in place and exit the programming mode.

**NOTE:** The program will save automatically in 60 seconds if no additional changes are made in that time frame; however, you can exit any time within the 60 second window by pressing Pour/Cancel. The changes you’ve made will be saved.

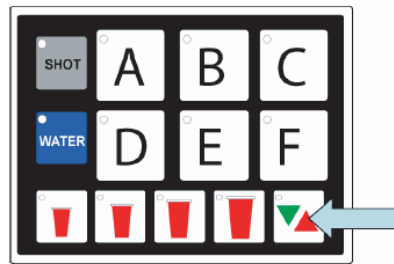
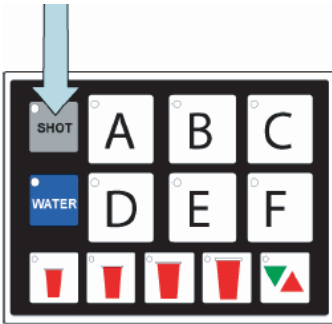
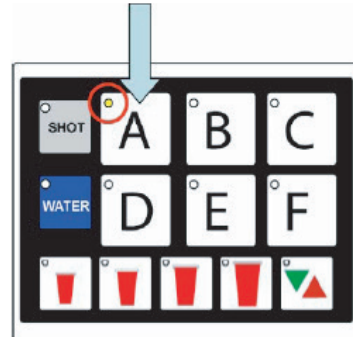
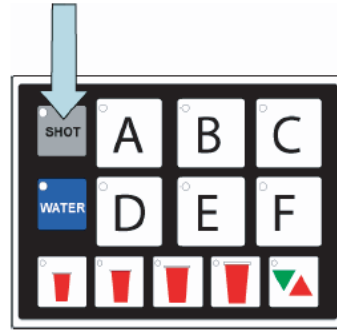

## 2.3 FLOW RATE CHECK

The Dispenser's water flow rate can be checked/calibrated using the on board computer as a timer. To check/adjust flow rate:

- A. Remove splashguard and module cover to expose flow controls and solenoids.
  1. All active brands should have their shutoffs in the open position as illustrated below.
    - CW = Carbonated Water (sparkling)
    - PW = Plain Water (still)

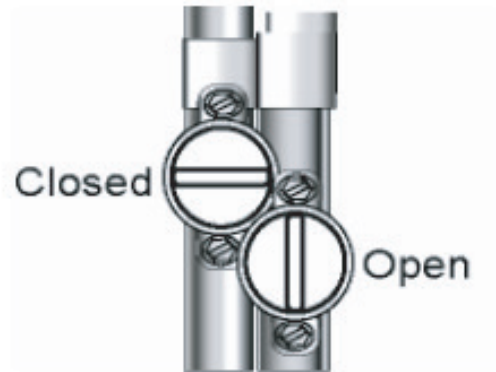
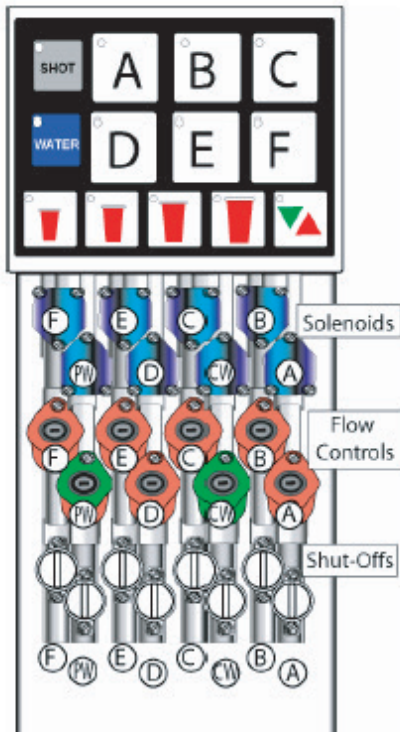

- B. Press the A and B buttons at the same time for five seconds.
  1. The Pour/Cancel button will illuminate and the shot LED will blink 5 times.

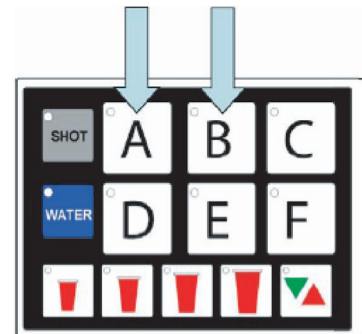

- C. Remove outer nozzle and insert syrup separator.
  1. This is important to do during flow rate check so you can determine if the separator has been properly installed.

**NOTE:** Water will leak through to the syrup chamber if not properly installed.

- D. Place a ratio cup under the nozzle and press a brand button.
  1. The brand's water module will open and pour for four seconds.

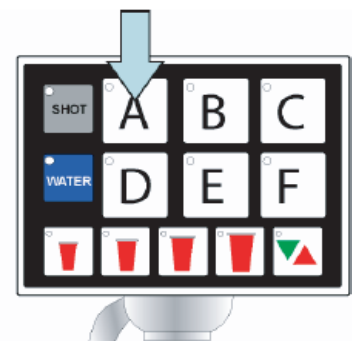

**NOTE:** Only water will pour during the flow rate check.

- E. Check for 10 oz of water in the ratio cup.
  1. If above or below 10 oz, adjust the water flow control (shown on previous page) and recheck.

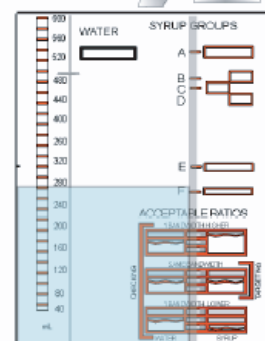

## 2.4 RATIO PROCESS

- A. Remove outer nozzle and insert MVU separator if not done on previous step.
- B. Prime separator by running the valve.
- C. Press and fill the ratio cup to the appropriate levels.
- D. Check/adjust ratio on each brand.
  1. Use flow controls to adjust syrup.

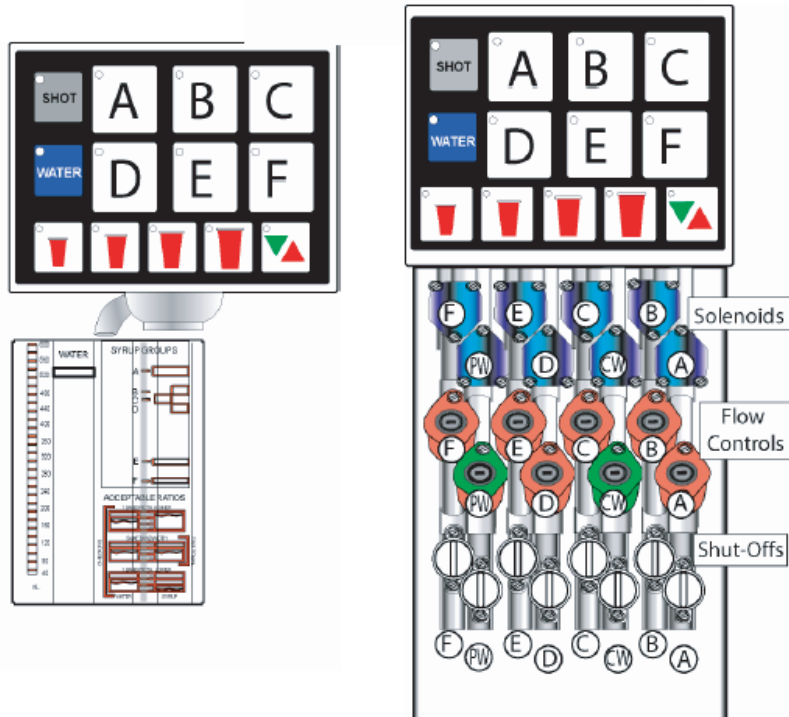

## 2.5 PORTION CONTROL PROGRAMMING (MVU) (NO TOP-OFF)

- A. Press the S and XL at the same time for five seconds to enter the portion setting mode.
  1. The Pour/Cancel light will illuminate and the shot light will blink two times.
- B. Press the Brand button.
  1. The selected brand's LED will illuminate.

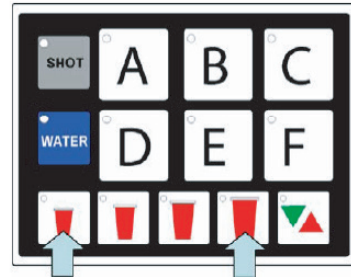

2. Multiple brands can be programmed at the same time to pour the same amounts for each size during this step.

Do this by selecting several brand buttons; however, the first button selected will illuminate and only its beverage will pour. The other brands selected will flash slowly.

3. If multi-brand programming, do not set carbonated drinks and non-carbonated drinks at the same time because carbonated drinks will foam.

**NOTE:** The LED will blink twice and turn off if the brand has been programmed as a flavor shot instead of a drink. You will need to reprogram the brand as a drink prior to setting the portion.

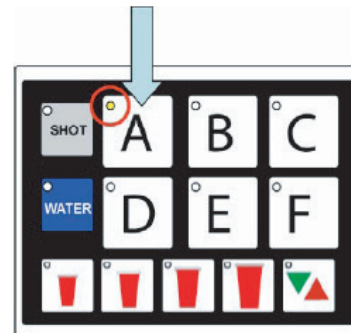

- C. Fill cup 1/3 full with ice and place under the nozzle, push and hold a drink “size” button until the cup is full.
1. Once the pour is completed, the LED will blink slowly to indicate that a new pour duration has been programmed for that key.
- D. Repeat this step for each of the other size cups.  
 E. Select other brands and repeat these steps for each.  
 F. Press the “Pour/Cancel” button to save programming.

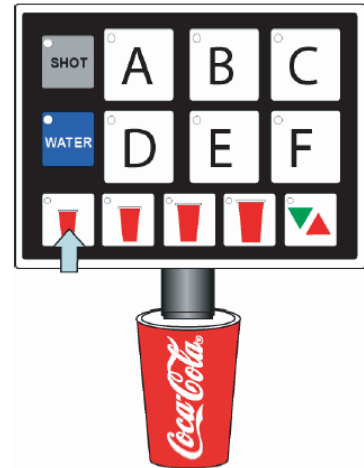

**NOTE:** The program will save automatically in 60 seconds if no additional changes are made in that time frame; however, you can exit any time within the 60 second window by pressing Pour/Cancel. The changes you’ve made will be saved.

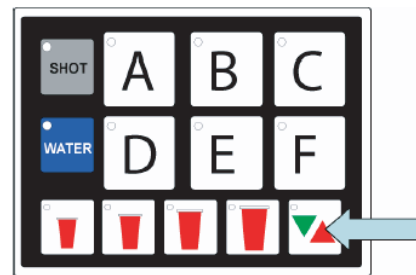
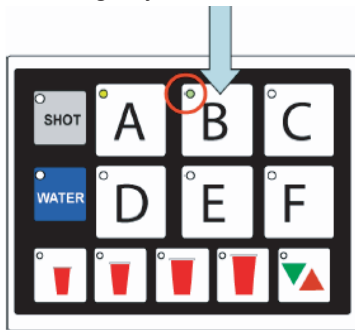

## 2.6 PORTION CONTROL PROGRAMMING WITH TOP-OFF (MVU)

- A. Press the S, L, and Pour/Cancel buttons at the same time for two seconds to enter portion setting mode.
1. The pour/Cancel light will illuminate and the shot light will blink three times. B. Press the brand button.
- B. Press the brand button.
1. The selected brand’s LED will illuminate.
  2. Multiple brands can be programmed at the same time to pour the same amounts for each size during this step. Do this by selecting several brand buttons; however, the first button selected will illuminate and only its beverage will pour. The other brands selected will flash slowly.
  3. If multi-brand programming, do not set carbonated drinks and non-carbonated drinks at the same time because carbonated drinks tend to pour faster.

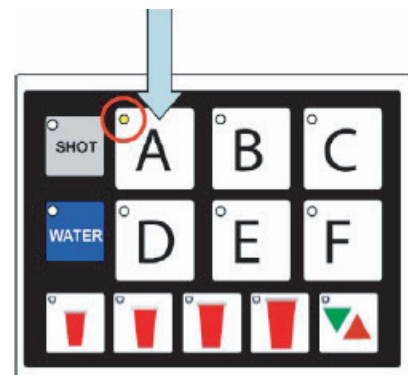
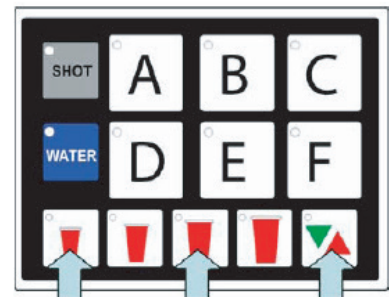

## 2.7 SHOT SIZE PROGRAMMING

Flavor shot portions can be adjusted using the MVU touchpad and a graduated cylinder. To adjust flavor shots:

- A. While in Portion Control Programming, press the Shot button.
  1. Pressing the Shot button again will exit Shot Size Programming.

- B. Press a "Brand" button. The brand button will illuminate.

**NOTE:** If brand is not enabled for shot mode, the LED light on that brand will blink twice and turn off.

- C. Place a graduated cylinder under the nozzle.
- D. Press and hold the XL portion button until the portion size is achieved. Target is 30 ml (1 Oz) of syrup for an XL portion for most customers.
  1. The XLRG LED will blink slowly to indicate that a new shot duration has been programmed.

**NOTE:** The other size buttons are proportioned automatically based on the amount poured in XL mode:

Small = 25% of XL portion

Medium = 50% of XL portion

Large = 75% of XL portion

- E. Repeat steps B through D for each of the other brands.
- F. Press Pour/Cancel to save the settings.

**NOTE:** The Program will save automatically in 60 seconds if no additional changes are made in that time frame; however, you can exit any time within the 60 seconds window by pressing Pour/Cancel. The changes you've made will be saved.

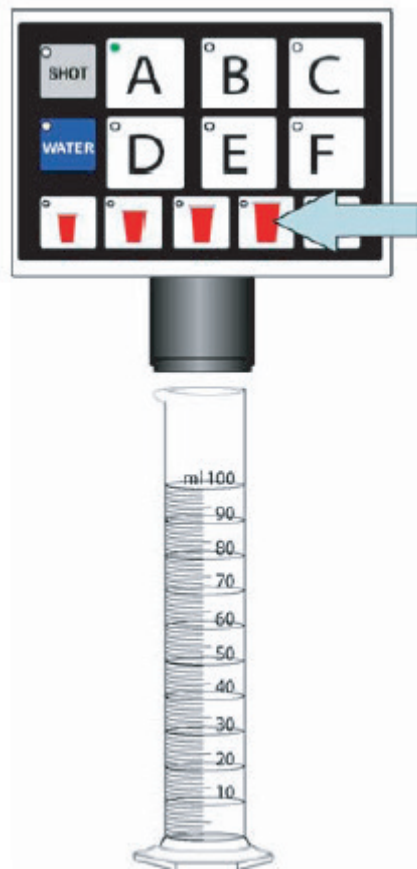
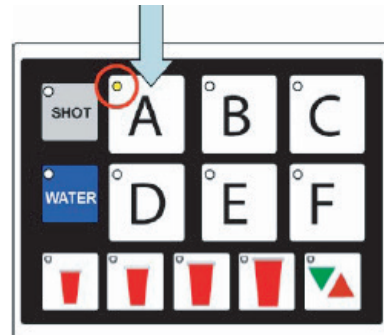
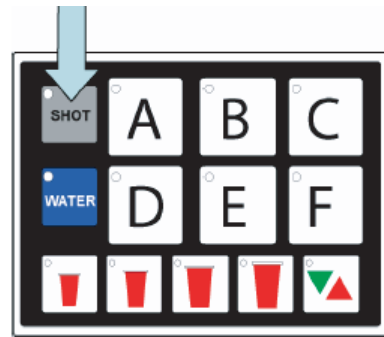

## 2.7 SHOT SIZE PROGRAMMING (CONTINUED)

### DISPENSER OPERATION

Crew Serve Beverage Dispensing  
Flavor Shot Dispensing - Portion Control

- A. Place cup under MVU nozzle.
- B. Press the "Shot" button.
  1. The "Shot" LCD will stay illuminated (active) for 10 seconds.
- C. Select Brand Button.
  1. Brand will stay illuminated for up to ten seconds.
  2. Touch brand again to deactivate.
- D. Select portion control size button to begin dispensing flavor shot.
  1. Press "Pour/Cancel" to stop dispense mode. Beverage Dispensing - Portion Controlled

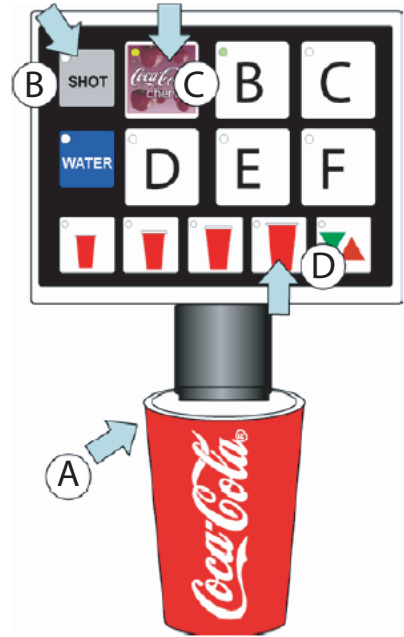

### BEVERAGE DISPENSING - PORTION CONTROLLED

- A. Press the brand button.
  1. Button stays active for 10 seconds or until another brand is pressed.
- B. Press a portion control size button.
  1. Beverage will pour.
  2. Press the Pour/Cancel to stop pour prior to complete dispense.

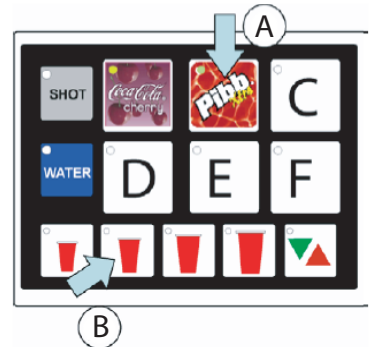

### BEVERAGES - MANUAL DISPENSE ON PORTION CONTROL

- A. Press the brand button.
  1. Button stays active for ten seconds or until another brand is pressed.
- B. Press and hold the pour/cancel button.
  1. The beverage continues to pour until the button is released.
  2. The selection will stay in memory for ten seconds.
  3. The valve can pour for a maximum of thirty seconds.

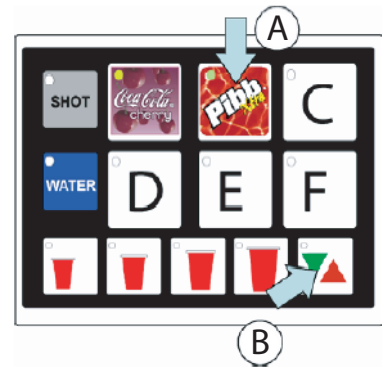

### 3. RECOMMENDED SERVICE AND MAINTENANCE

#### 3.1 SCHEDULED

- A. Daily – See Section 3.4 for daily cleaning.
- B. Monthly – See Section 3.5 for monthly cleaning.
- C. Periodic Sanitizing - See sections 3.2 and 3.3 for sanitizing requirements.
- D. As needed - Keep exterior surfaces of dispenser (including drip tray and cup rest) clean with a damp, clean cloth.

#### 3.2 CLEANING AND SANITIZING SYSTEMS

##### A. General Information

- 1. Lancer equipment (new or reconditioned) is shipped from the factory cleaned and sanitized according to NSF guidelines. The operator of the equipment must provide continuous maintenance as required by this manual and state and local health department guidelines to maintain proper operation and sanitization.

**NOTE:** The cleaning and sanitizing procedures below pertain to the Lancer equipment identified by this manual. If other equipment is being cleaned, follow the guidelines established for that equipment.

- 2. Cleaning and sanitizing should be accomplished only by trained personnel. Use sanitary gloves during cleaning and sanitizing operations. Observe all safety precautions. Follow instruction warnings on the cleaning product.

**WARNING** TO AVOID CONTAMINATION, DO NOT DISCONNECT WATER LINES WHEN CLEANING AND SANITIZING SYRUP LINES.

**ADVERTENCIA** PARA EVITAR LA CONTAMINACIÓN, NO DESCONECTE LAS LÍNEAS DE AGUA AL LIMPIAR Y DESINFECTAR LÍNEAS DE JARABE.

**AVERTISSEMENT** POUR ÉVITER TOUTE CONTAMINATION, NE PAS DÉCONNECTER LES CONDUITES D'EAU LORS DU NETTOYAGE ET L'ASSAINISSEMENT DES CHAÎNES DE SIROP.



##### 3. Recommended Preparation of Cleaning Solutions.

- a. Cleaning solutions (for example, Ivory Liquid, Calgon, etc.) mixed with clean, potable water at a temperature of 90 to 110 degrees Fahrenheit should be used to clean equipment. The mixture ratio, using Ivory Liquid, is one ounce of cleanser to two gallons of water. A minimum of four gallons of cleaning mixture should be prepared.

**NOTE:** Extended lengths of product lines may require that an additional volume of solution be prepared.

- b. Any equivalent cleanser may be used as long as it provides a caustic-based, non-perfumed, easily-rinsed mixture containing at least two percent sodium hydroxide (NaOH).

##### 4. Recommended Preparation of Sanitizing Solutions.

- a. Sanitizing solutions should be prepared according to the manufacturer's written recommendations and safety guidelines. Follow manufacturer's requirements so that the solution provides 200 parts per million (PPM) chlorine at a temperature of 90°F to 120°F. Prepare a minimum of four gallons of sanitizing solution.

**NOTE:** Extended lengths of product lines may require that an additional volume of solution be prepared.

- b. Any sanitizing solution may be used as long as it is prepared according to the manufacturer's written recommendations and safety guidelines, and provides 200 parts per million (PPM) chlorine.

### 3.3 CLEANING AND SANITIZING BAG-IN-BOX (BIB) SYSTEMS

- A. Disconnect syrup quick disconnect coupling from syrup packages and connect coupling to a bag valve removed from an empty Bag-in-Box package.
- B. Place end of syrup inlet line, with bag valve attached, in a clean container filled with clean, potable, roomtemperature water.
- C. Place waste container under applicable dispensing valve. Activate valve until water is dispensed. Flush and rinse line and fittings for a minimum of 60 seconds to remove all traces of residual product.

**NOTE:** Extended lengths of product lines may require additional time for flushing and rinsing lines.

- D. Prepare cleaning solution as described in Section 3.2 above. Place end of syrup inlet line in container filled with cleaning solution.
- E. Place waste container under applicable dispensing valve. Activate valve and draw cleaning solution through lines for a minimum of sixty seconds. This will ensure line is flushed and filled with cleaning solution. Allow line to stand for at least thirty minutes.
- F. Place end of syrup inlet line in a clean container filled with clean, potable water at a temperature of 90 to 110 degrees F.
- G. Place waste container under applicable dispensing valve. Activate valve to flush and rinse line and fittings for a minimum of sixty seconds to remove all traces of cleaning solution. Continue rinsing until testing with phenolphthalein shows that the rinse water is free of residual detergent.
- H. Prepare sanitizing solution as described in Section 3.2 above. Place end of syrup inlet line in container filled with sanitizing solution which has been prepared.
- I. Activate valve and draw sanitizing solution through line for a minimum of sixty seconds. This will ensure line is flushed and filled with sanitizing solution. Allow line to stand for at least fifteen minutes.
- J. Remove bag valve from quick disconnect coupling and reconnect syrup inlet line to syrup package. Ready unit for operation.

	<b>WARNING</b> FLUSH SANITIZING SOLUTION FROM SYRUP SYSTEMS AS INSTRUCTED. RESIDUAL SANITIZING SOLUTION LEFT IN SYSTEM COULD CREATE HEALTH HAZARD.
	<b>ADVERTENCIA</b> ENJUAGUE SOLUCIÓN DESINFECTANTE DE SISTEMAS DE JARABE SEGÚN LAS INSTRUCCIONES. RESIDUAL SOLUCIÓN DESINFECTANTE SISTEMA DE IZQUIERDA EN PODRÍA GENERAR RIESGOS PARA LA SALUD.
	<b>AVERTISSEMENT</b> RINCER D'ASSAINISSEMENT SOLUTION DE SYSTÈMES DE SIROP COMME INDIQUÉ. RESIDUAL SOLUTION DÉSINFECTANTE GAUCHE DANS UN SYSTÈME POURRAIT CREER DANGER POUR LA SANTÉ.

- K. Draw drinks and refill lines with end product to flush sanitizing solution from the dispenser.

**NOTE:** A fresh water rinse cannot follow sanitization of equipment. Purge only with the end use product. This is an NSF requirement.

- L. Test dispenser in the normal manner for proper operation. Taste dispensed product to ensure there is no offtaste. If off-taste is found, flush syrup system again.
- M. Repeat cleaning, rinsing, and sanitizing procedures for each valve circuit.

### 3.4 NOZZLES

- A. Nozzle may be cleaned and sanitized in the same manner.
  - 1. Disconnect power so the valve will not be activated during the cleaning procedure. Remove nozzle. Wash parts in cleaning solution, then immerse them in a bath of sanitizing solution for 15 minutes.
  - 2. Visually inspect around nozzle area for syrup residue. This area may be cleaned with warm water and cloth or with the nozzle brush supplied.
  - 3. Wearing sanitary gloves, remove, drain and air dry the nozzle.
  - 4. Wearing sanitary gloves, replace nozzle.
  - 5. Connect power. Unit is ready for operation.

#### 4. TROUBLESHOOTING

TROUBLE	CAUSE	REMEDY
4.1 No carbonation.	<p>A. Carbonator motor not running.</p> <p>B. Absence of CO2 gas.</p> <p>C. Gas only from valves.</p> <p>D. Carbonator tank air bound.</p> <p>E. CO2 gas pressure below 90 PSI (0.621 MPA).</p> <p>F. Carbonator motor running continuously.</p>	<p>A. Check power supply. Be sure toggle switch is in ON position.</p> <p>B. Replace with full tank of CO2 gas.</p> <p>C. Check for power failure. Check fuses. Clean strainer on pump.</p> <p>D. Relieve gas pressure in tank by pulling ring on safety relief valve until water spurts out.</p> <p>E. Reset high pressure CO2 gas regulator to 90-110 PSI. Change CO2 tank if required.</p> <p>F. Check switch on carbonator. Check water in check valve for blockage. Check carbonator control. Check carbonator pump for efficiency.</p>
4.2 Noisy carbonator pump.	<p>A. Insufficient water supply or water leak, allowing air to be pulled into pump.</p> <p>B. Loose pump coupling.</p>	<p>A. Provide adequate water supply. Check strainer for cleanliness.</p> <p>B. Tighten set screw on pump coupling.</p>
4.3 Off-taste in soda.	<p>A. Leaking water check valve, allowing carbonated water back into supply line.</p>	<p>A. Dismantle and clean check valve. Replace O-ring if torn or distorted.</p>
4.4 Valves inoperable.	<p>A. Loss of power.</p>	<p>A. Check power supply to see if plugged in. Check transformer circuit breaker. Check main power circuit breaker 110V.</p>

#### 5. DISPENSER DISPOSAL



To prevent possible harm to the environment from improper disposal, recycle the unit by locating an authorized recycler or contact the retailer where the product was purchased. Comply with local regulations regarding disposal of the refrigerant and insulation.

## NOTES

# 6. ILLUSTRATIONS AND PARTS LISTINGS

## 6.1 MVU TOWER ASSEMBLY

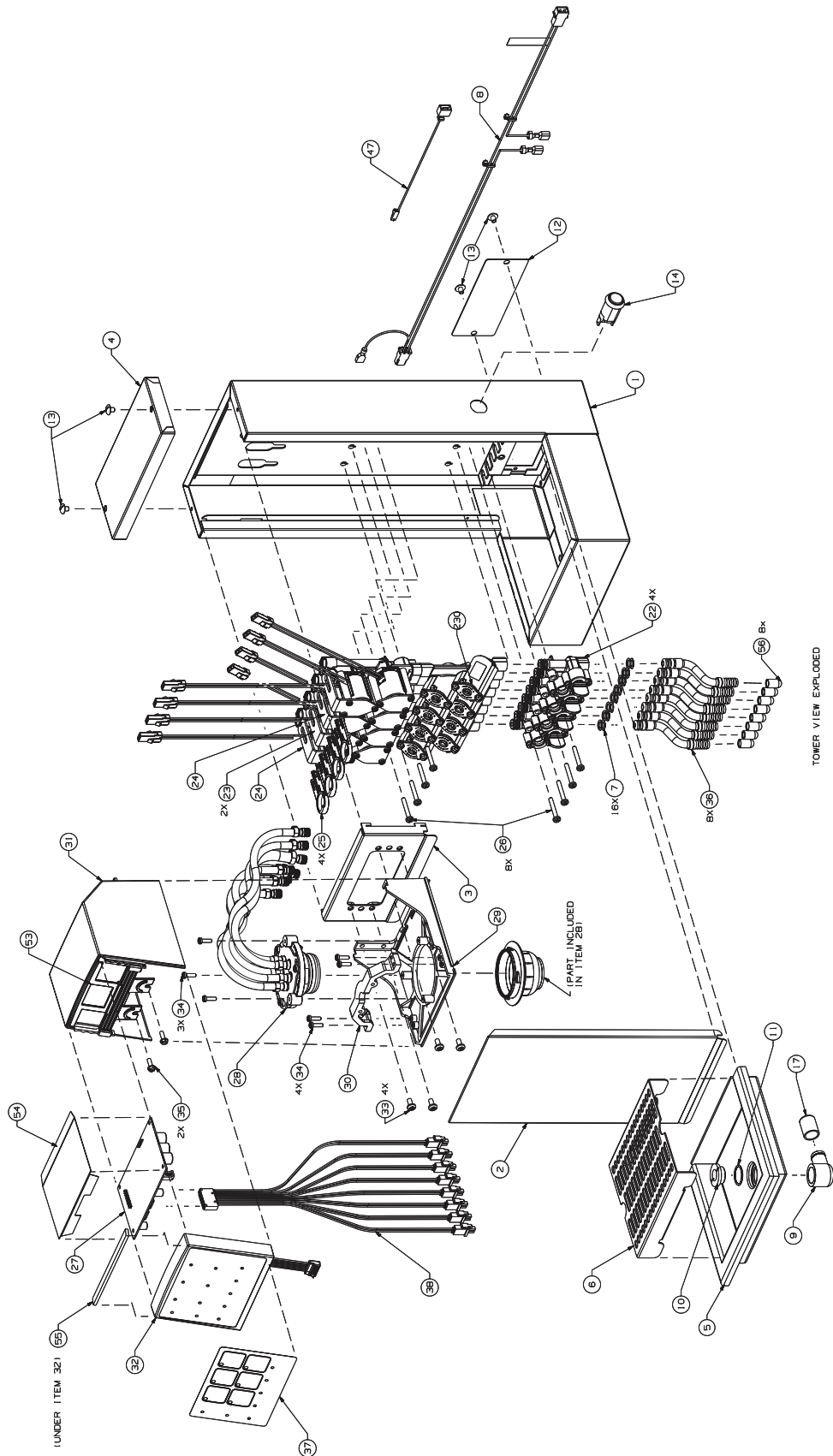

## 6.1 MVU TOWER ASSEMBLY (CONTINUED)

<u>Item</u>	<u>Part No.</u>	<u>Description</u>	<u>Item</u>	<u>Part No.</u>	<u>Description</u>
1	51-6311	Structure, MVU	31	54-0464	Cover Assy, MVU
2	30-1649/01	Plate, Splash	32	52-3160	Panel Assy, ID
3	30-10431	Plate, Faucet	33	04-0236	Scr, 10-24x.375
4	30-1648	Cap, Tower, 1&2	34	04-0470	Scr, 6-19x.500
5	05-0953	Drip Tray, Two	35	04-0267/02	Scr, 8-16x.5, PL
6	30-1651	Cup Rest	36	48-2862	Tube Assy
7	02-0003	O-Ring, 2-011	37	06-3077	Overlay, Button
8	52-3260	Harness Assy, Power	-	06-3191	Overlay, Flavor Shots Only
9	05-0610/01	Elbow, Drain, WI	38	52-3169	Harness Assy
10	05-0611	Collar, Drain	39	06-0111*	Label Soda
11	02-0221	O-Ring, 2-018	40	06-0112*	Label Water,
12	30-0612	Plate, Back,	41	06-3127*	Label, "A A A A"
13	04-0148	Scr, 10-32x.250	42	06-3128*	Label, "B B B B"
14	12-0097	Switch, Key	43	06-3129*	Label, "C C C C"
15	28-0777*	Manual, Install	44	06-3130*	Label, "D D D D"
16	08-0184*	Tubing, Gray	45	06-3131*	Label, "E E E E"
17	05-08968	Cap, Drain, Vinyl	46	06-3132*	Label, "F F F F"
18	06-0075/01*	Nmplt, Vinyl	47	52-3208	Harness, MVU
19	25-0069/01*	Transformer	48	06-3125	Label, Plmb/Wir
20	52-1772/01*	Harness Assy, Wire	49	90-0065*	Carton, Single
21	06-1061*	Template, Base	50	90-0004*	Bag, 9x15, Clr
22	17-0622-2	Body Assy	51	90-0444*	Bag, 38.000 x 3
23	19-0471/01	Valve Assy, 2-Pack, Syrup/ Syrup (85-3136-MVUFC uses 3)	52	90-0066*	Pad, Tower
24	19-0472/01	Valve Assy, 2-Pack, Syrup/ Water (not included on 85-3136-MVUFC)	53	05-2831	MVU Shield, Plastic
25	05-2775/01	Retainer, Slide	54	05-2832	MVU Control BD, CVR, Plastic
26	04-0481	Scr, 8-32x1.125	55	50-0586	Insulation Strip, MVU Tower
27	64-5011/02	PCB Assy	56	04-0559	Cap, Protective, Vinyl, VC-375-8
28	49-0330	Nozzle Assy			
-	49-0331	Nozzle Assy, Flavor Shots Only			
29	05-2687/01	Plate, Nozzle			
30	05-2682	Bracket, Cover			

\*Items not shown.

---

***LANCER***<sup>®</sup>

Lancer Corp.

800-729-1500

Technical Support/Warranty: 800-729-1550

[custserv@lancercorp.com](mailto:custserv@lancercorp.com)

[lancercorp.com](http://lancercorp.com)