

**SELF-SERVE LEVER**

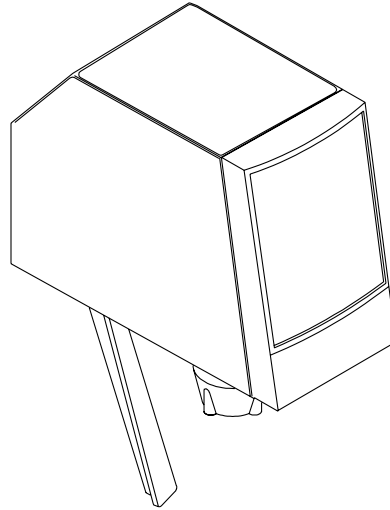

**STANDARD LEVER**

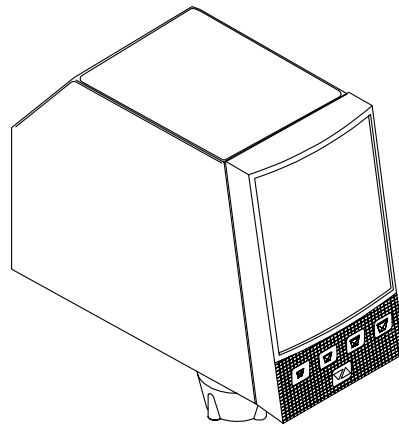

**PORTION CONTROL**

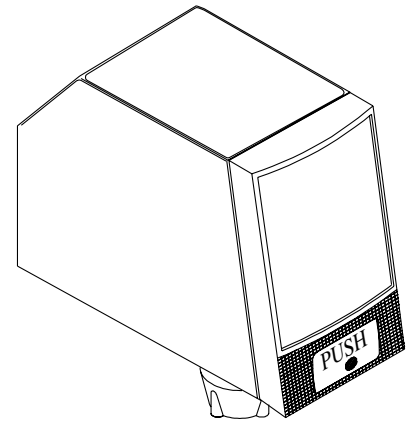

**PUSH BUTTON**

Lancer Corp.  
6655 Lancer Blvd.  
San Antonio, Texas 78219

800-729-1500  
Technical Support/Warranty: 800-729-1550  
custserv@lancercorp.com  
lancercorp.com

Manual PN: 28-0301/04

APRIL 2012

**FOR QUALIFIED INSTALLER ONLY**



MODEL NO.



### **ABOUT THIS MANUAL**

This booklet is an integral and essential part of the product and should be handed over to the operator after the installation and preserved for any further consultation that may be necessary. Please read carefully the guidelines and warnings contained herein as they are intended to provide the user with essential information for the continued safe use and maintenance of the product. In addition, it provides GUIDANCE ONLY to the user on the correct services and site location of the unit.

The installation and relocation, if necessary, of this product must be carried out by qualified personnel with up-to-date safety and hygiene knowledge and practical experience, in accordance with current regulations.

## **TABLE OF CONTENTS**

<b>SPECIFICATIONS.....</b>	<b>3</b>
<b>1. PRICIPLE OF OPERATION.....</b>	<b>4</b>
<b>2. CLEANING AND SANITIZING INSTRUCTIONS.....</b>	<b>5</b>
<b>3. VALVE SETUP.....</b>	<b>7</b>
<b>4. SYRUP RESTRICTOR SETTING.....</b>	<b>7</b>
<b>5. SYRUP PURGE PLUG.....</b>	<b>7</b>
<b>6. PROGRAMMER OPERATING PROCEDURES.....</b>	<b>8</b>
<b>7. PORTION CONTROL PROGRAMMING PROCEDURES.....</b>	<b>9</b>
<b>8. COVER AND ID PANEL.....</b>	<b>10</b>
<b>9. VALVE.....</b>	<b>11</b>
<b>10. LEVER ARM.....</b>	<b>11</b>
<b>11. NOZZLE/DIFFUSER.....</b>	<b>12</b>
<b>12. CIRCUIT BOARD.....</b>	<b>12</b>
<b>13. FLOWMETER.....</b>	<b>13</b>
<b>14. FLOW WASHER ASSEMBLY.....</b>	<b>14</b>
<b>15. SYRUP REGULATOR.....</b>	<b>14</b>
<b>16. WATER SOLENOID ACCESS.....</b>	<b>15</b>
<b>17. WATER SOLENOID ASSEMBLY.....</b>	<b>17</b>
<b>18. SYRUP BODY ACCESS.....</b>	<b>18</b>
<b>19. SYRUP SOLENOID ACCESS.....</b>	<b>20</b>
<b>20. SYRUP SOLENOID ASSEMBLY.....</b>	<b>21</b>
<b>21. TROUBLESHOOTING.....</b>	<b>22</b>
<b>22. APPLIANCE DISPOSAL.....</b>	<b>25</b>
<b>23. VOLUMETRIC VALVE ASSEMBLY.....</b>	<b>26</b>

## ABOUT THE VALVE

THE VOLUMETRIC VALVE DISPENSES POST-MIX BEVERAGES ACCURATELY OVER A BROAD RANGE OF PRESSURES AND SYRUP VISCOSITIES. CONFIGURATIONS, FROM A CUP LEVER TO A PORTION CONTROL PANEL INTERFACE, ALLOW THE VOLUMETRIC VALVE TO FIT MANY DIFFERENT APPLICATIONS. THE VOLUMETRIC VALVE MOUNTS TO A STANDARD LEV® BACK BLOCK AND UTILIZES THE SAME COVER AS THE LEV®.

## SPECIFICATIONS

### FINISHED DRINK FLOW RATES:

- 3.0 ounces per sec (88.7 ml/sec), Standard
- 2.25 ounces per sec (66.5 ml/sec)
- 1.50 ounces per sec (44.4 ml/sec)

### PRESSURE REQUIREMENTS:

Flowing pressure (at the valve)

	<b>Minimum</b>	<b>Maximum</b>
<b>Water</b>	40 psig (2.8 Kg/cm <sup>2</sup> )	110 psig (7.7 Kg/cm <sup>2</sup> )
<b>Syrup (Sugar)</b>	20 psig (1.4 Kg/cm <sup>2</sup> )	70 psig (4.9 Kg/cm <sup>2</sup> )
<b>Syrup (Diet)</b>	10 psig (0.7 Kg/cm <sup>2</sup> )	70 psig (4.9 Kg/cm <sup>2</sup> )

### ELECTRICAL REQUIREMENT:

24 VAC, 50/60 Hz

### MOUNTING

Mounts on the same hole pattern with the same mounting screws as the following valves: Lancer LEV® Cornelius SF-1 Dole SEV McCann Turbo Flo Jr. Dole FFV

### MAINTENANCE TOOLS

When troubleshooting and accessing the Volumetric Valve, the following tools will be needed:

#### Standard

- #2 Phillips Head Screw Driver
- Flat End Screw Driver
- Dow Corning® 111 Valve Lubricant & Sealant
- Volumetric Valve Hand Held Programmer (Lancer PN 52-1420/02; CCPN 532179)

#### Optional

- 3/16 inch Hex Socket Driver
- Ohmmeter

### BEFORE GETTING STARTED

Each unit is tested under operating conditions and is thoroughly inspected before shipment. At the time of shipment, the carrier accepts responsibility for the unit. Upon receiving the unit, carefully inspect the carton for visible damage. If damage exists, have the carrier note the damage on the freight bill and file a claim with carrier. Responsibility for damage to the dispenser lies with the carrier.

# 1. PRINCIPLE OF OPERATION

**FIGURE 1. COMPONENTS**

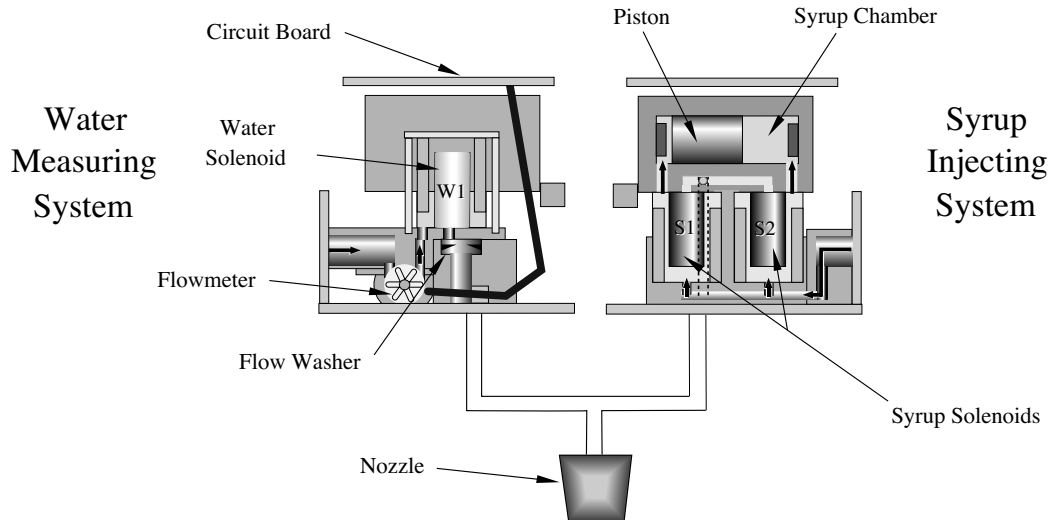

- A. Three systems in the Volumetric Valve work together to maintain an accurate syrup to water ratio:
  - The circuit board with its computer.
  - The water measuring system.
  - The syrup injecting system.
- B. Set the ratio by using the hand held programmer (Lancer PN 52-1420/02; CCPN 532179).
- C. When a customer activates the valve, the water starts flowing to the nozzle. The flow washer ensures that the water does not flow too fast.
- D. The paddle wheel in the flowmeter begins to spin, sending signals to the circuit board (see below).
- E. The computer on the circuit board monitors the signals and determines when to inject syrup into the water stream. The circuit board energizes one syrup solenoid and then the other. This alternating action injects a metered amount of syrup into the water. This happens seven to eight (7-8) times a second (see Fig. 2 and 3).
- F. The circuit board indicates which solenoid is activated with the LEDs mounted on the front of the board. The green LED corresponds to the water solenoid and the red LEDs correspond to the syrup solenoids.

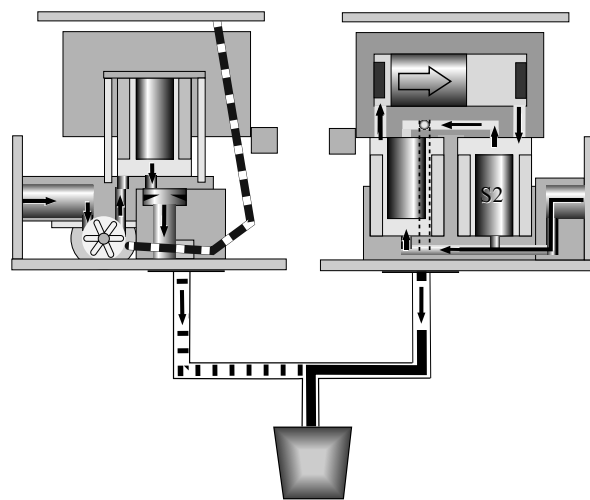
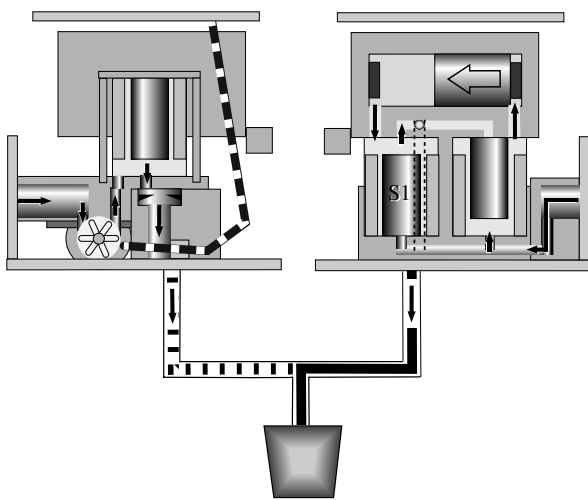

**FIGURE 2. OPERATION DIAGRAM - VALVE ON**

**FIGURE 3. OPERATION DIAGRAM - VALVE ON**

## 2. CLEANING AND SANITIZING INSTRUCTIONS

### GENERAL INFORMATION

- A. The cleaning and sanitizing procedures provided pertain to the Lancer equipment identified by this manual. If other equipment is being cleaned, follow the guidelines established by the manufacturer for that equipment.
- B. Lancer equipment (new or reconditioned) is shipped from the factory cleaned and sanitized in accordance with NSF guidelines. The equipment must be cleaned and sanitized after installation is complete. The operator of the equipment must provide continuous maintenance as required by this manual and state and local health department guidelines to ensure proper operation and sanitation requirements are maintained.
- C. Cleaning and sanitizing should be accomplished only by trained personnel. Sanitary gloves are to be used during cleaning and sanitizing operations. Applicable safety precautions must be observed. Instruction warnings on the product being used must be followed.

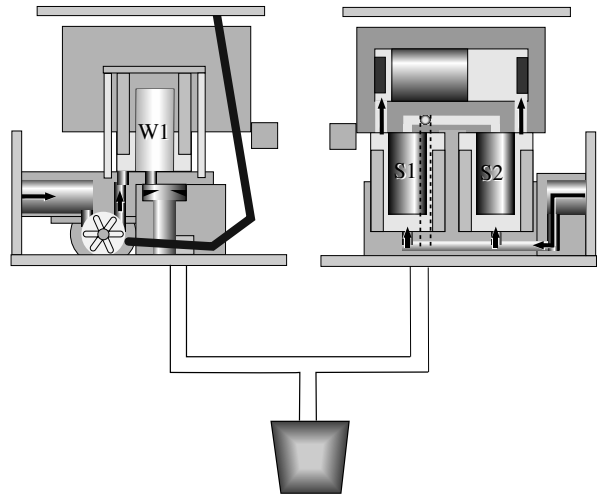

FIGURE 4. OPERATION DIAGRAM - VALVE OFF

### 2.1 CLEANING SOLUTION

Mix a mild, non-abrasive detergent (e.g. Sodium Laureth Sulfate, dish soap) with clean, potable water at a temperature of 90 to 110°F (32 to 43°C). The mixture ratio is one ounce of cleaner to two gallons of water. Prepare a minimum of five gallons of cleaning solution. Do not use abrasive cleaners or solvents because they can cause permanent damage to the unit. Ensure rinsing is thorough, using clean, potable water at a temperature of 90 to 110 degrees F. Extended lengths of product lines may require additional cleaning solution.

### 2.2 SANITIZING SOLUTION

Prepare sanitizing solutions in accordance with the manufacturer's written recommendations and safety guidelines. The solution must provide 50 to 100 parts per million (PPM) chlorine (e.g. Sodium Hypochlorite or bleach). A minimum of five gallons of sanitizing solution should be prepared. Any sanitizing solution may be used as long as it is prepared in accordance with the manufacturer's written recommendations and safety guidelines, and provides 50 to 100 parts per million (PPM) chlorine.



**WARNING** IF A POWDER SANITIZER IS USED, DISSOLVE IT THOROUGHLY WITH HOT WATER PRIOR TO ADDING TO THE SYRUP SYSTEM. ENSURE SANITIZING SOLUTION IS REMOVED FROM THE DISPENSER AS INSTRUCTED. AVOID GETTING SANITIZING SOLUTION ON CIRCUIT BOARDS. DO NOT USE STRONG BLEACHES OR DETERGENTS; THESE CAN DISCOLOR AND CORRODE VARIOUS MATERIALS. DO NOT USE METAL SCRAPERS, SHARP OBJECTS, STEEL WOOL, SCOURING PADS, ABRASIVES, OR SOLVENTS ON THE DISPENSER. DO NOT USE HOT WATER ABOVE 140° F (60° C). THIS CAN DAMAGE THE DISPENSER.

**ADVERTENCIA** SI SE USA UN HIGIENIZADOR EN POLVO, DISUÉLVALO BIEN EN AGUA ANTES DE AGREGARLO AL SISTEMA DE CONCENTRADO. EL USO DE AGUA CALIENTE CONTRIBUYE A DISOLVER LOS HIGIENIZADORES EN POLVO. ASEGÚRESE DE HABER ELIMINADO LA SOLUCIÓN DE ESTERILIZACIÓN DEL DISPENSADOR DE ACUERDO CON LAS INSTRUCCIONES. LOS RESIDUOS DE LA SOLUCIÓN DE ESTERILIZACIÓN REPRESENTAN UN PELIGRO PARA LA SALUD. EVITE QUE LA SOLUCIÓN DE ESTERILIZACIÓN LLEGUE A LAS PLACAS DE CIRCUITOS. NO USE LAVANDINAS NI DETERGENTES QUE PODRÍAN QUITAR EL COLOR Y CORROER DISTINTOS MATERIALES. NO USE RASPADORES METÁLICOS, OBJETOS FILOSOS, LANA DE ACERO, ESTROPAJOS, ABRASIVOS NI SOLVENTES EN EL DISPENSADOR. NO USE AGUA CALIENTE A MÁS DE 140 °F (60 °C). PODRÍA DAÑAR EL DISPENSADOR.

**AVERTISSEMENT** AVANT L'INJECTION DANS LE SYSTÈME, IL FAUDRA QUE LA POUDRE SEPTIQUE SOIT DISSOLUE ENTIÈREMENT DANS CHAUDE. L'EAU CHAUDE PERMETTRA UN MEILLEUR PROCÈS DE DISSOLUTION. SUIVANT LES INSTRUCTIONS JOINTES, IL EST IMPÉRATIF QUE LA SOLUTION SEPTIQUE SOIT ENTIÈREMENT ENLEVÉE. EVITEZ DE METTRE LA SOLUTION EN CONTACT AVEC LES CIRCUITS. N'UTILISEZ PAS DE JAVELLISANTS OU DEDÉTERGENTS FORTS; CEUX-CI PEUVENT DÉCOLORER ET CORRODER DIVERS MATÉRIEAUX. N'UTILISEZ PAS DE RACLEURS EN MÉTAL, D'OBJETS POINTUS, DE LAINE D'ACIER, DE TAMPONS À RÉCUPER, D'ABRASIFS OU DE SOLVANTS SUR LE DISTRIBUTEUR. N'UTILISEZ PAS DE L'EAU CHAUDE DE PLUS DE 140 DEGRÉS F (60 DEGRÉS C). CECI PEUT ENDOMMAGER LE DISTRIBUTEUR.

### 2.3 DAILY NOZZLE/DIFFUSER CLEANING (SEE FIGURE 5)

Use the following procedures to clean the nozzle, and the diffuser assembly, each day:

- A. Remove nozzle by twisting it counter-clockwise and pulling it down.
- B. Pull the diffuser assembly down to remove it from the valve.
- C. Wash the nozzle and diffuser with warm water.
- D. If needed, apply 111 lubricant to the o-ring on the diffuser assembly. Next, carefully press it into the diffuser mounting area on the underside of the valve.
- E. Install the nozzle by inserting it into the bottom plate and twisting it clockwise to lock it in place.

### 2.4 MONTHLY NOZZLE/DIFFUSER SANITIZING

- A. Disconnect power, so the valve will not be inadvertently activated while cleaning.
- B. Remove nozzle by twisting it counter-clockwise and pulling it down.
- C. Pull the diffuser assembly down to remove it from the valve.
- D. Wash the nozzle and diffuser with the cleaning solution.
- E. Immerse the nozzle and diffuser in a bath of the sanitizing solution for 15 minutes.
- F. While the parts are in the sanitizing solution, visually inspect around the nozzle mounting area on the valve for syrup residue. Using a cloth or nozzle brush and warm water, clean this area.
- G. Wipe off the dispensing lever and any other areas that may have been splashed by syrup.
- H. Wearing sanitary gloves, remove, drain, and air dry the nozzle and diffuser.
- I. Wearing sanitary gloves, carefully press the diffuser into the mounting area on the underside of the valve.
- J. Wearing sanitary gloves, install the nozzle by inserting it into the bottom plate and twisting it clockwise to lock it in place.
- K. Connect power and replace cover. Valve is ready for operation.
- L. Draw drinks to flush residual sanitizing solution. Taste the beverage to verify that there is no off taste. If an off taste is found, additional flushing may be required.

### 2.5 VALVE AND SYSTEM SANITIZING

- A. The complete valve and dispenser system must be sanitized during initial installation. Follow the manufacturer's instructions when scheduling and conducting dispenser sanitizing. The valve must be sanitized once every two weeks. The valve may remain on the dispensing tower during the sanitizing process.
- B. For syrup side line priming, and cleaning and sanitization procedures, refer to the Syrup Purge Plug (Lancer PN 52-1912) in the Valve Set-Up Section.

FIGURE 5. NOZZLE/DIFFUSER

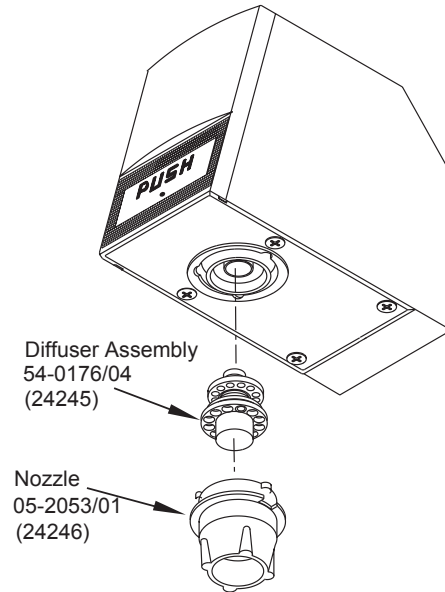

NOTE: Part Number in ( ) is a Coca-Cola PN

FIGURE 6. NOZZLE/DIFFUSER

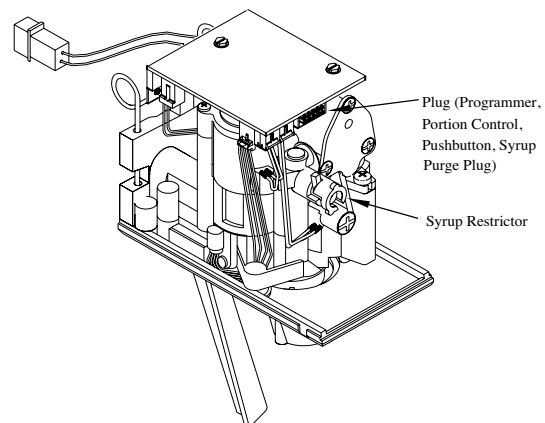

### 3. VALVE SETUP

The following steps provide an overview of the valve set-up procedures:

- A. Mount valve on back block (see Section 9).
- B. Verify that power supply is 24 VAC, 50/60 Hz, then connect to valve.
- C. Connect water (soda) and syrup supplies. Flowing pressures must meet valve specifications (see Specifications, Page 3).
- D. Set ratio and select carbonation. See Section 6 for hand held programmer procedures.
- E. Set the syrup restrictor for either diet or sugar syrup (see Section 4).
- F. Purge syrup lines using the hand held programmer (see Section 6).
- G. Install valve cover, and if necessary, connect ID panel (see Section 8).
- H. Activate valve to test dispensing.

### 4. SYRUP RESTRICTOR SETTING

- A. SUGAR SYRUP AND DIET SYRUP FROM FIGALS: Restrictor out and down. Syrup restrictor is not in use.
- B. DIET SYRUP FROM BAG-IN-A BOX: Restrictor in and up. Syrup restrictor is in use.

### 5. SYRUP PURGE PLUG

- A. The Syrup Purge Plug (PN 52-1912), places the valve in continuous syrup side operation.
- B. The targeted uses for the purge plug consist of priming the syrup line on an initial Volumetric Valve install, and for cleaning and sanitization of the syrup side of the dispensing unit.

#### 5.1 OPERATION OF THE SYRUP PURGE PLUG

	<p><b>CAUTION</b> VALVE CONSUMES 12VA IN A CONTINUOUS SYRUP SIDE OPERATION. USING A STANDARD 75VA TRANSFORMER, UP TO SIX (6) VOLUMETRIC VALVES CAN BE OPERATED IN SYRUP PURGE MODE SIMULTANEOUSLY.</p>
	<p><b>PRECAUCIÓN</b> LA VÁLVULA CONSUME 12VA EN UNA OPERACIÓN LATERAL DE OPERACIÓN DEL JARABE, USANDO UN TRANSFORMADOR ESTÁNDAR DE 75VA, SE PUEDEN OPERAR HASTA SEIS (6) VÁLVULAS VOLUMÉTRICAS SIMULTÁNEAMENTE EN UN MODO DE PURGA DEL JARABE.</p>
	<p><b>ATTENTION</b> LA PUISSANCE ÉLECTRIQUE CONSOMMÉE PAR L'ÉLECTRO-VANNE EST DE L'ORDRE DE 12 VOLTS-AMPÈRES EN COURS DE TRAITEMENT CONTINU DU CÔTÉ SIROP. LORSQU'UN TRANSFORMATEUR STANDARD DE 75 VOLTS-AMPÈRES SERA UTILISÉ, JUSQU'À SIX (6) VANNES VOLUMÉTRIQUES POURRONT ÊTRE MISES EN OEUVRE SIMULTANÉMENT EN MODE PURGE.</p>

- A. Turn off electrical power to all valves.
- B. Install syrup purge plugs into the valve or valves to be primed or sanitized. The syrup purge plug installs in the ten-pin connector of the Volumetric Valve circuit board.
- C. Turn on electrical power to the valves. At this time, the syrup side of the valves will begin continuous operation.
- D. When through with the priming or sanitization operation, syrup purge operation can be stopped either of two ways:

Method 1: Turn off electrical power to all valves, remove syrup purge plugs from the valves. Turn on electrical power to all valves. Tap valve lever or push button to ensure proper operation of all valves.

Method 2: Remove syrup purge plug from the valves while they are in purge operation. In this case, the valve may continue in the purge mode for up to six (6) seconds after removal of the plug (this is normal). Tap valve lever or push button to ensure proper operation of all valves.

- E. Using a standard 75 VA transformer, up to six (6) Volumetric Valves can be operated in the syrup purge mode simultaneously.

FIGURE 7. SYRUP PURGE PLUG

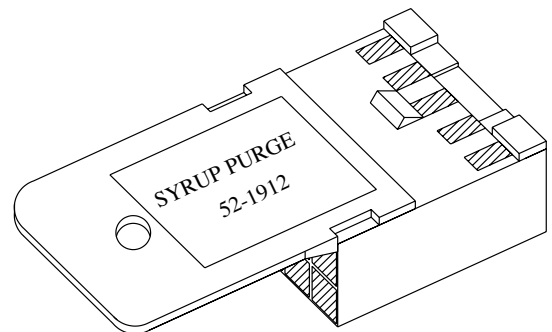

## 6. PROGRAMMER OPERATING PROCEDURES

### 6.1 CONNECTING

- A. Remove the ID panel from the front of the valve.
- B. Insert the programmer's 10-pin connector into the ID Panel plug on the front of the circuit board.
- C. When properly connected, the programmer will run a self diagnostic test. The display will show all "8"s with the decimal points lighted.  
After three (3) seconds, the display indicates the setting of the dip switches.
- D. If the programmer does not run its diagnostic test properly, disconnect it and try plugging it in again. If the programmer still fails, replace the programmer.

FIGURE 8 - HANDHELD PROGRAMMER



### 6.2 FUNCTIONS



**Read Memory:** Press to read and display the current settings programmed into the valve memory (i.e., S/W revision, ratio, and carb/non carb settings).



**Read Dip Switches:** Press to read the dip switch settings. NOTE: Dip Switches were used on some field test valves (refer to PN 28-0301, 12/20/95)



**Write Memory:** Press to write the programmer's displayed ratio and carbonation settings into the valve's memory.



**Timed 5 Second Water:** Press to pour water for five (5) seconds. The programmer will display the ratio, the counts from the flowmeter, the flow rate in oz/sec, and the flow rate in ml/sec.



**Timed 5 Second Pour:** Press to dispense a five (5) second pour of water and syrup for ratio testing. When complete, the programmer displays the ratio, carbonation settings, and total Flowmeter counts.



**Syrup Purge:** Press and release to dispense a six (6) second syrup purge. Continue holding to purge syrup from system.



**Ratio + (Plus):** Pressing this button will increase the ratio number on the display.



**Ratio - (Minus):** Pressing this button will decrease the ratio number on the display.



**Carb Toggle:** Press to toggle the carbonation setting from carbonated "C" to non-carbonated water "n".



**Pour/Stop:** Press this button to manually pour a mixed drink. This button will also stop a timed pour.

### 6.3 SETTING THE RATIO/CARBONATION

- A. Connect the programmer to the Valve.
- B. Press the **[Read Mem]** button.
- C. Press the **[Ratio +]** or the **[Ratio -]** key until the desired ratio is displayed.
- D. Verify drink type. Press **[Carb Toggle]** to select **[C]** for carbonated or **[n]** for non-carbonated.
- E. Press the **[Enter]** button to program the valve with the setting on the display
- F. Verify Ratio by pressing **[Read Mem]**.
- G. Disconnect the programmer.

### 7.0 PORTION CONTROL PROGRAMMING PROCEDURES

The following procedures describe the operation and programming of portion control ID panels for the Volumetric Valve.

#### 7.1 OPERATION

- A. Cup buttons are Small, Medium, Large, Extra-Large.
- B. Press and release the desired cup size. Valve will fill cup as programmed (See below).
- C. Pour/Cancel Button
  1. Push and release to cancel or stop valve dispensing.
  2. Push and hold for continuous pour.
- D. Water Button
  1. Push and hold for continuous water pour.
  2. Valve will dispense carbonated or non-carbonated water, depending on its location on the dispenser.

#### 7.2 TEACH AND LEARN PORTION CONTROL PROGRAMMING

In this mode, the valve will record (learn) the steps to fill each cup size, including the top off delay time. When activated, the valve dispenses the appropriate drink volume. If a top off has been entered, the valve will pause for the programmed length of time. Finally, the valve will dispense the correct top off amount.

- A. Initial Install Procedure
  1. Simultaneously, press and hold the small cup button and the extra-large cup button switches on the portion control until the LED light in center of module starts blinking, then release switches. The blinking LED indicates that the set mode is active.
  2. Put desired amount of ice in cup, place cup under valve and push selected size button (small, medium, large, or extra-large). Hold button in until cup fills to desired portion, then release button.
  3. Top off: If a top off is not needed, go to Step 4. Wait for foam to settle, then actuate button again to top off. **NOTE:** Only one (1) top off is allowed.
  4. Repeat steps 2 and 3 for other drink sizes. Go to Step 5 to exit program mode.
  5. Press and release pour/stop button to return the portion control to the operational mode. Blinking LED light will go out.
  6. Repeat steps 1 through 5 for remaining valves.

**FIGURE 9 - PORTION CONTROL, CUP BUTTONS**

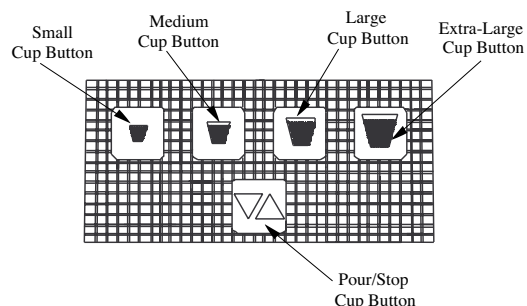

**FIGURE 10 - PORTION CONTROL, CUP BUTTONS, WITH WATER**

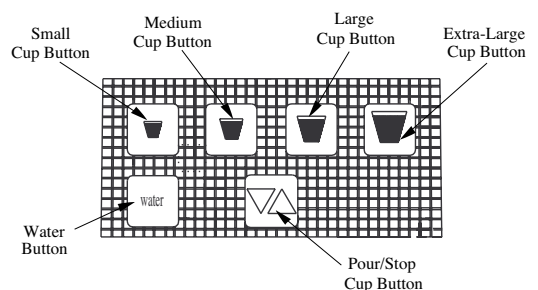

#### 7.3 TO CHANGE DISPENSE SIZE

Use procedures in the Initial Install Procedure discussed above; it is not necessary to reprogram every size.

## 7.4 CALIBRATED CUP PORTION CONTROL PROGRAMMING

In this mode, the valve adds the volume from each programming step to the total drink size. When activated, the valve dispenses the total drink, without pauses.

- A. Simultaneously, press and hold the small and large buttons (see Figures 9 and 10) on the portion control until the LED light in the center starts blinking, then release switches.
- B. Place volume cup under nozzle of valve to be calibrated.
- C. Press appropriate size switch and fill volume cup to a point just short of the calibration mark on the volume cup. The LED will stay lighted constantly while programming an individual cup size.
- D. Let foam settle, jog size switch until liquid reaches the calibration mark on the volume cup.
- E. Press pour/stop button to end programming for selected cup size. LED will start blinking.
- F. To program another cup size, repeat steps B through E, this section (above).
- G. To exit the calibrated cup programming mode, press the pour/stop button when the LED is blinking. If the LED is lighted constantly, press the pour/stop button once to end the cup size program (LED starts blinking) and again to exit the program mode (LED off).

## 8. COVER AND ID PANEL

### 8.1 REMOVAL

- A. ID panel: Slide ID panel up until it detaches from cover.



**CAUTION** PULL CAREFULLY, IF WIRES FOR A PUSHBUTTON OR PORTION CONTROL ARE ATTACHED.

**PRECAUCIÓN** TIRE CUIDADOSAMENTE SI ESTÁN ADHERIDOS LOS CABLES A UN BOTÓN DE EMPUJE O UN CONTROL DE PORCIÓN.

**ATTENTION** SI L'ENSEMBLE EST RELIÉ PAR FILS À UN BOUTON-POUSOIR DE COMMANDE OU À UNE COMMANDE DE RÉGLAGE DE DÉBIT INDIVIDUEL, LE TIRER DÉLICATEMENT.

- B. ID panel connector (If applicable): The circuit board connector on the Volumetric Valve has an interlock feature that acts to keep an ID panel plug or Hand Held Programmer (HHP) plug properly connected. The interlock feature consists of a recess in the circuit board connector housing and a raised tab on the housing plug. See Figure 11, for the raised tab configuration.

When removing the connector, it is important to hold the housing and not the wires. The housing easily slides out of the circuit board connector by placing a very slight downward pressure onto the housing as it is removed (see Figure 12).

**NOTE:** Pulling straight out while holding onto the wires is not recommended and will likely cause damage to the valve, ID panel and/or HHP cable.

- C. Cover: Loosen, but do not remove, cover screw. Pull cover straight up, until it is clear of the valve body.

**NOTE:** Push Button ID panel or lever must be connected to run "Syrup Pour" test from dip switches. Push Button ID panel or lever must be disconnected to use the hand held programmer.

FIGURE 11

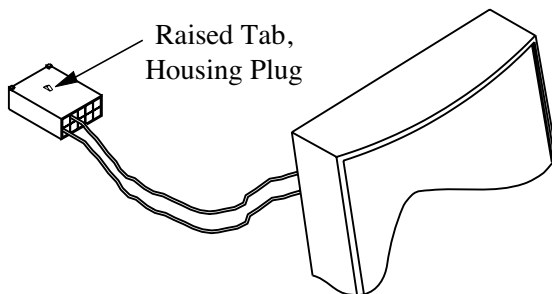
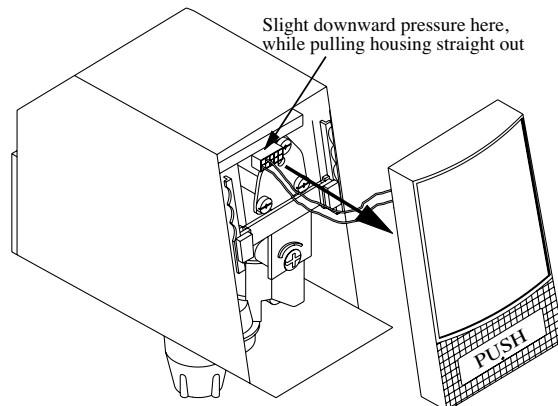

FIGURE 12



## 8.2 INSTALLATION

- A. Plug the ID panel connector (if applicable) into the front of the circuit board.
- B. Slide cover over valve, making certain that wires do not get pinched.

**NOTE:** If solenoids were replaced or moved, ensure terminal blocks do not interfere with cover. Check for proper orientation.

- C. Tighten cover screw.



**CAUTION** DO NOT PINCH OR DAMAGE ID PANEL WIRES DURING INSTALLATION.

**PRECAUCIÓN** NO PERFORE O DAÑE LOS CABLES DEL PÁNEL DURANTE LA INSTALACIÓN.

**ATTENTION** S'ASSURER DE NE PAS Pincer OU ENDOMMAGER LES FILS DU PANNEAU ÉLECTRIQUE ID LORS DU MONTAGE.

- D. Align the bottom of the ID panel with the guide slots on the front of the cover. Slide the ID panel down into place.

**NOTE:** Attach the ID panel connector before installing cover to keep wires out of the way.

## 9. VALVE

### 9.1 REMOVAL FROM BACK BLOCK

- A. Remove cover and ID panel (see Section 8).
- B. Turn back block shut-offs to the closed position.
- C. Activate the valve (press lever arm or pushbutton) to relieve pressure.
- D. Unplug 24 Volt supply.
- E. Raise valve retainer. **NOTE:** The retainer cannot be pulled up until the back block shut-offs are properly closed.
- F. Pull the valve off of the back block.

### 9.2 MOUNTING ON BACK BLOCK

- A. Check o-rings on back block. Replace o-rings, if necessary.
- B. Apply 111 Lubricant to o-rings, if necessary.
- C. Press valve into the back block.
- D. Lower the valve retainer to lock the valve in place.
- E. Turn the back block shut-offs to the open position.
- F. Connect the 24 Volt supply to the plug on the circuit board.
- G. Install cover and ID panel.

**FIGURE 13**

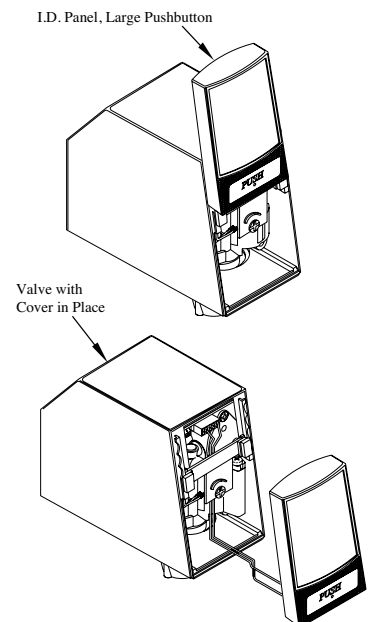

**FIGURE 14**

## 10. LEVER ARM

### 10.1 REMOVAL

- A. Remove cover and ID panel (see Section 8).
- B. Remove valve from back block (see Section 9).
- C. Insert lever arm into bottom plate and snap pivot axle into back of valve as shown in Figure 14.

### 10.2 INSTALLATION

- A. With the valve detached from the back block, insert the magnet end of the lever arm into the hole on the bottom, backside of the valve.
- B. Pull the lever arm back while pushing it into the valve, so the pivot axle can be positioned over the slot formed by the valve body and bottom plate. Release the valve to allow the pivot axle to be seated in the slot.
- C. Mount valve in back block.
- D. Install ID panel and cover.

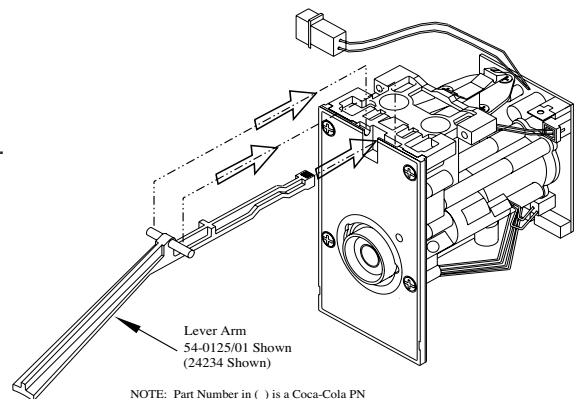

## 11. NOZZLE/DIFFUSER

### 11.1 REMOVAL

- A. Remove nozzle, by twisting it counter-clockwise and pulling it in a downward direction (see Figure 15).
- B. Remove the diffuser assembly, by pulling it in a downward direction.

### 11.2 ASSEMBLY

- A. Slide o-ring into the groove on the end of the diffuser assembly, if necessary.
- B. Apply 111 Lubricant to o-ring, as required.
- C. Insert diffuser assembly carefully into the underside of the valve.
- D. Install nozzle by inserting it into the bottom plate and twisting it in a clockwise direction to lock it into place.

FIGURE 15

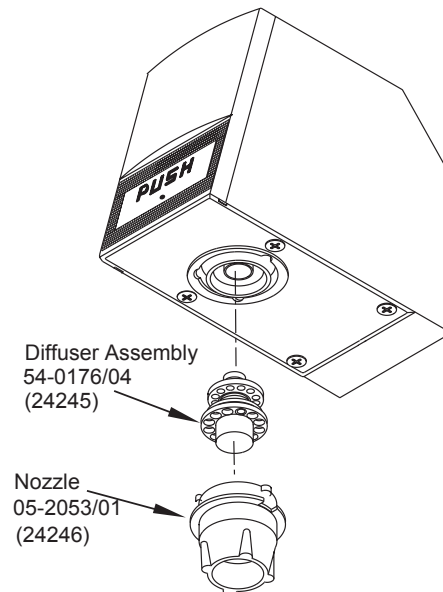

NOTE: Part Number in ( ) is a Coca-Cola PN

## 12. CIRCUIT BOARD

### 12.1 REMOVAL

- A. Unplug 24 Volt supply.
- B. Use a flat end screw driver to remove each of the screws holding the circuit board in place.
- C. Disconnect the solenoids and flowmeter from the circuit board, by pressing each connectors locking tab and pulling it down out of its socket.
- D. Lift the circuit board off of the valve.

### 12.2 INSTALLATION

- A. Plug the connector from the rear syrup solenoid into the receptacle on the underside of the circuit board near the rear of the valve.
- B. Plug the connector from the soda solenoid into the receptacle located at the front, left corner of the circuit board.

**NOTE:** Each solenoid plugs into the nearest circuit board socket.

- C. Plug the connector from the front syrup solenoid into the receptacle between the soda solenoid connector and the 10-pin connector on the front of the circuit board.
- D. Plug the 4-pin connector from the flowmeter in the 4-pin receptacle near the front corner of the circuit board.
- E. Position circuit board on the mounting posts on top of the syrup body 10-pin connector to the front.
- F. Secure circuit board with two (2) screws.
- G. Connect 24 Volt supply.

FIGURE 16

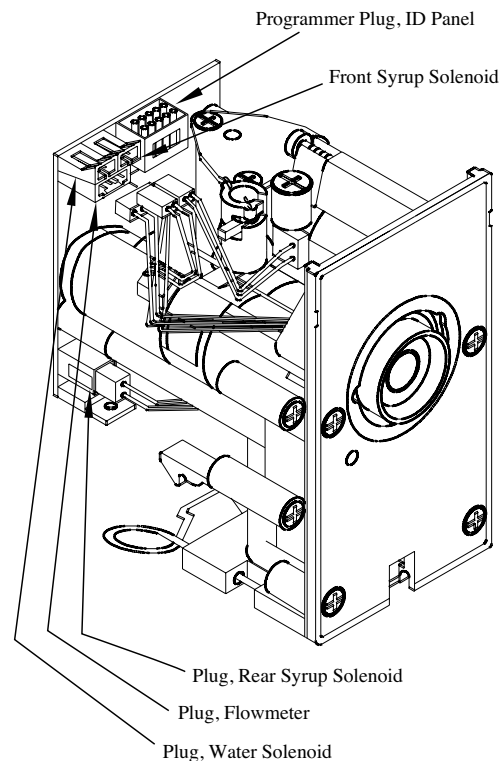

## 13. FLOWMETER

### 13.1 REMOVAL

- A. Remove cover and ID panel (see Cover and ID Panel, Section 8).
- B. Remove valve from back block (see Valve, Section 9).
- C. Remove nozzle/diffuser (see Nozzle/ Diffuser, Section 11).
- D. Remove lever arm, if applicable (see Lever Arm, Section 10).
- E. Remove four (4) screws holding the bottom plate in place.
- F. Pull bottom plate off.

 **CAUTION** USE CARE WHEN REMOVING THE SCREWS TO AVOID DAMAGING THE FLOWMETER SENSOR WIRES.

**PRECAUCIÓN** TENGA CUIDADO CUANDO RETIRE LOS TORNILLOS PARA EVITAR DAÑAR LOS CABLES DEL SENSOR DEL FLUXÓMETRO.

**ATTENTION** LORSQU'IL S'AGIRA DE DÉPOSER LES VIS, IL CONVIENDRA DE PRENDRE SOIN DE NE PAS ENDOMMAGER LES FILS DU CAPTEUR DU DÉBITMÈTRE.

- G. Remove four (4) screws holding the flowmeter body in place.
- H. Carefully pull the flowmeter body and o-ring off of the valve. Use caution to not pull the rotor and bearings out of the flowmeter body as ball bearings are snapped into place.

### 13.2 INSTALLATION

- A. Place the o-ring in the groove in the flowmeter body.

 **CAUTION** DO NOT PINCH THE FLOWMETER O-RING DURING INSTALLATION. THE O-RING MUST STAY IN THE GROOVE ON THE FLOWMETER BODY.

**PRECAUCIÓN** NO PELLIZQUE EL ANILLO O- DEL FLUXÓMETRO DURANTE LA INSTALACIÓN. EL ANILLO O- DEBE MANTENERSE EN LA RANURA SOBRE EL CUERPO DEL FLUXÓMETRO.

**ATTENTION** FAIRE ATTENTION DE NE PAS Pincer LE JOINT TORIQUE DU DÉBITMÈTRE LORS DU MONTAGE. LE JOINT TORIQUE DEVRA RESTER LOGÉ DANS LA RAINURE PRÉVUE SUR LE CORPS DU DÉBITMÈTRE.

- B. If necessary, carefully apply a small amount of 111 Lubricant to o-ring. NOTE: Do not get lubricant in the flowmeter.
- C. With the wires exiting toward the front of the valve, carefully press the flowmeter sub-assembly into place on the underside of the valve body. The flat surface of the flowmeter must be flush against the mounting surface of the valve body.
- D. Install four (4) screws to hold the flowmeter in place. Gently position the sensor wires so they are not pinched or scraped when the screws are installed. NOTE: The flowmeter screws are 5/8" long, and are longer than the bottom plate screws.
- E. Thread the connector attached to the flowmeter sensor wires through hole on the valve body that is in front of flow washer mounting port (see Figure 18).
- F. Place the flowmeter sensor wires around the outside of the flow washer mounting port, so that they will not interfere with the bottom plate installation.

 **CAUTION** DO NOT PINCH ANY WIRES WITH THE BOTTOM PLATE.

**PRECAUCIÓN** NO PELLIZQUE NINGÚN CABLE CON EL FONDO.

**ATTENTION** VEILLER À CE QUE L'EMBASE NE VIENNE PAS Pincer LES FILS.

- G. Line up holes on the bottom plate with the screw holes on the underside of the valve body. The raised sections around the screw holes should fit completely in the counterbores on the bottom plate.
- H. Secure bottom plate in place with four (4) screws.
- I. Replace nozzle/diffuser and lever arm (if applicable).
- J. Install ID panel and cover.

FIGURE 17

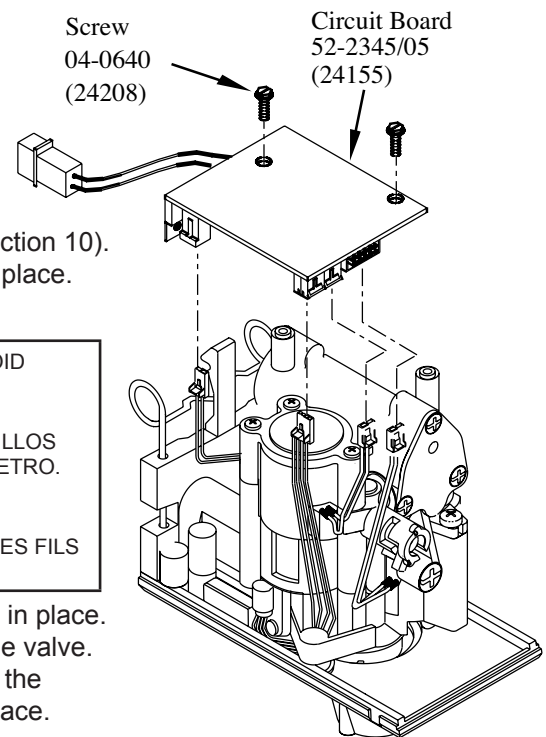

## 14. FLOW WASHER ASSEMBLY

### 14.1 REMOVAL

- A. Remove cover and ID panel (see Cover and ID Panel, Section 8).
- B. Remove valve from back block (see Valve, Section 9).
- C. Remove nozzle/diffuser (see Nozzle/ Diffuser, Section 11).
- D. Remove lever arm, if applicable (see Lever Arm, Section 10).
- E. Remove four (4) screws holding the bottom plate in place.
- F. Pull bottom plate off.
- G. Pull the flow washer assembly out of its port, next to the nozzle mount on the underside of the valve. The flow washer assembly will be one of the following:
  1. Gray, 3.0 ounce/sec product flow.
  2. White, 2.25 ounce/sec product flow.
  3. Red, 1.5 ounce/sec product flow.

**FIGURE 18 - FLOW WASHER/SYRUP PLUG ACCESS**

### 14.2 INSTALLATION

- A. Install o-rings, if necessary.
- B. Apply 111 Lubricant to the o-rings, if necessary.
- C. Install the appropriate flow washer assembly into the keyed port on the underside of the valve body.

**NOTE:** The flow washer has a flat side and a concave side. The flow washer must be installed with the concave side facing the small diameter hole in the flow washer retainer.

- D. Place the flowmeter wires around the outside of the flow washer mounting port, so that they will not interfere with the bottom plate installation.
- E. Line up holes on the bottom plate with the screw holes on the underside of the valve body. The raised sections around the screw holes should fit completely in the counterbores on the bottom plate.

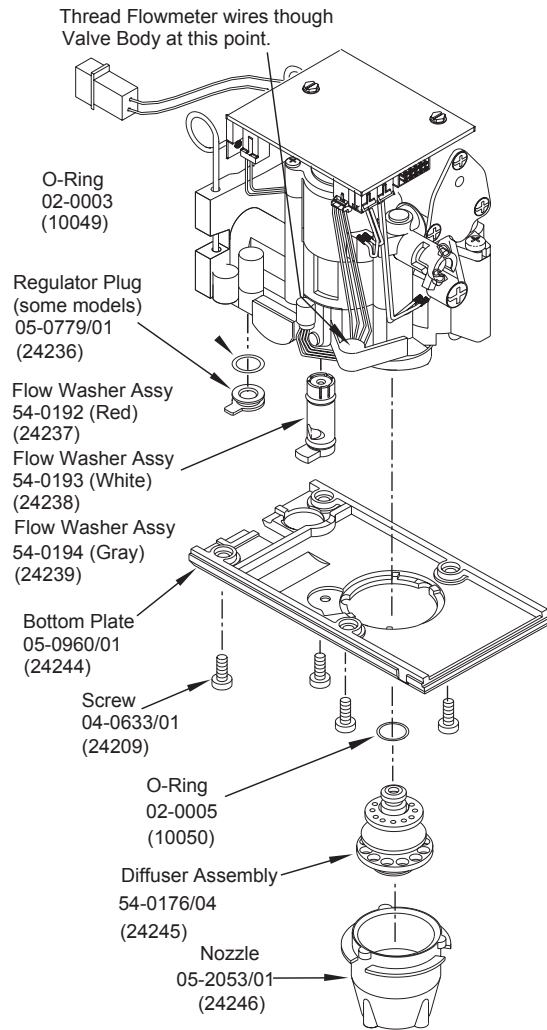

NOTE: Part Number in ( ) is a Coca-Cola PN

	<b>CAUTION</b> DO NOT PINCH ANY WIRES DURING INSTALL
	<b>PRECAUCIÓN</b> NO NO PELLIZQUE NINGÚN CABLE DURANTE LA INSTALACIÓN.
	<b>ATTENTION</b> VEILLER À NE COINCER AUCUN FIL LORS DU MONTAGE.

- F. Secure bottom plate in place with four (4) screws.
- G. Mount valve in back block.
- H. Replace nozzle/diffuser and lever arm (if applicable).
- I. Install ID panel and cover.

## 15. SYRUP REGULATOR

### 15.1 REMOVAL

- A. If the syrup regulator plug or its o-rings need to be replaced, remove the valve from the back block and take off the bottom plate.
- B. Pull the regulator plug from the regulator port near the back of the underside of the valve body.

**NOTE:** There is nothing mounted inside the regulator port.

## 15.2 INSTALLATION

- Install o-rings in groove on regulator plug.
- Apply 111 Lubricant to the o-ring.
- Insert regulator plug into keyed hole on the underside of the valve body.
- Place the flowmeter wires around the outside of the flow washer assembly, so that they will not interfere with the bottom plate installation.

	<b>CAUTION</b> DO NOT PINCH ANY WIRES DURING INSTALL
	<b>PRECAUCIÓN</b> NO NO PELLIZQUE NINGÚN CABLE DURANTE LA INSTALACIÓN.
	<b>ATTENTION</b> VEILLER À NE COINCER AUCUN FIL LORS DU MONTAGE.

- Line up holes on the bottom plate with the screw holes on the underside of the valve body.

	<b>CAUTION</b> BOTTOM PLATE HOLDS THE REGULATOR PLUG AND THE FLOW WASHER RETAINER IN PLACE. DO NOT PRESSURIZE UNTIL BOTTOM PLATE IS FIRMLY ATTACHED.
	<b>PRECAUCIÓN</b> LA PLACA INFERIOR SOSTIENE LA CLAVIJA DEL REGULADOR Y LA ARANDELA DE RETENCIÓN DEL FLUJO EN SU LUGAR. NO LA PRESIONE HASTA QUE LA PLACA INFERIOR SE HAYA COLOCADO FIRMEMENTE.
	<b>ATTENTION</b> L'EMBASE MAINTIEN LE CLAPET DU RÉGULA-TEUR AINSI QUE LE COLLIER DE RETENUE DU RÉDUCTEUR DE PRESSION EN PLACE. NE PAS METTRE SOUS PRESSION AVANT QUE L'EMBASE NE SOIT SOLIDEMENT FIXÉE.

- Secure bottom plate in place with four (4) screws.
- Mount valve on back block.
- Replace nozzle/diffuser and lever arm (if applicable).
- Install ID panel and cover.

## 16. WATER SOLENOID ACCESS

### 16.1 REMOVAL

- Disconnect valve from back block (see Valve, Section 9).
- Remove circuit board (see Circuit Board, Section 12).

	<b>CAUTION</b> AVOID DAMAGING OR DROPPING THE SOLENOID OR COMPONENTS WHEN THE RETAINER IS REMOVE.
	<b>PRECAUCIÓN</b> EVITE DAÑAR O TIRAR EL SOLENOIDE O LOS COMPONENTES CUANDO RETIRE EL RETENEDOR.
	<b>ATTENTION</b> ÉVITER D'ENDOMMAGER OU DE FAIRE TOMBER L'ÉLECTROVANNE OU AUTRES COMPOSANTS LORSQUE.

- Remove three (3) screws holding the water solenoid retainer in place. Remove the retainer.
- Take the water solenoid assembly out of the valve.

**FIGURE 19 - FLOWMETER ACCESS**

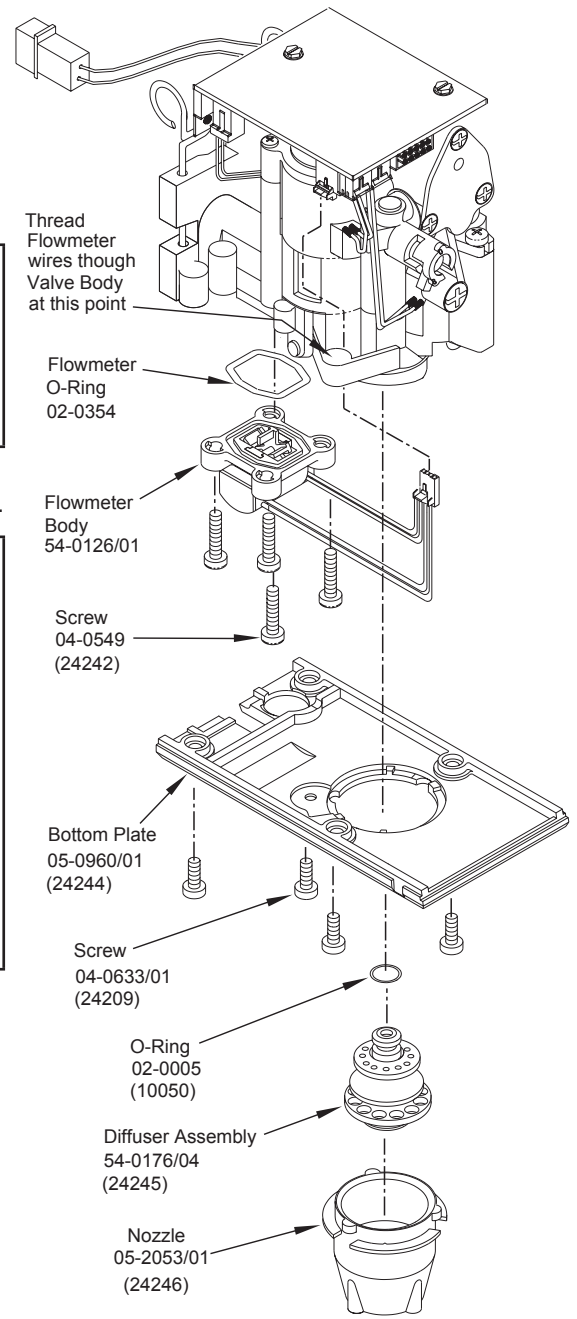

NOTE: Part Number in ( ) is a Coca-Cola PN

## 16.2 INSTALLATION

*If a water seat is already installed, skip to Step H.*

- A. Put o-ring in groove on water seat.



**CAUTION** USE CARE TO NOT DAMAGE SEATING AREA WHILE INSERTING WATER SEAT INTO VALVE BODY.

**PRECAUCIÓN** TENGA CUIDADO DE NO DAÑAR EL ÁREA DE ASIENTO MIENTRAS QUE INSERTA EL ASIENTO DE AGUA DENTRO DEL CUERPO DE LA VÁLVULA.

**ATTENTION** VEILLER À NE PAS ENDOMMAGER LA ZONE D'ÉTANCHÉITÉ À L'EAU LORS DE L'INSERTION DU SIÈGE DANS LE CORPS DE LA VANNE.

- B. Apply 111 Lubricant to outside edges of o-ring.  
C. Carefully press water seat into the hole at the base of the water solenoid mounting area in the valve body. Make certain that the water seat remains completely inserted into the hole. Apply more lubricant to the o-ring, if necessary,  
D. If necessary, install flow washer (See Flow Washer Assembly, Section 14).



**CAUTION** DO NOT PINCH ANY WIRES DURING INSTALL

**PRECAUCIÓN** NO NO PELLIZQUE NINGÚN CABLE DURANTE LA INSTALACIÓN.

**ATTENTION** VEILLER À NE COINCER AUCUN FIL LORS DU MONTAGE.

- E. Place the flowmeter wires around the outside of the flow washer assembly, so that they will not interfere with the bottom plate installation.  
F. Secure bottom plate in place with four (4) Screws.  
G. Apply 111 Lubricant to the outside edge of o-ring on the water solenoid sub-assembly.



**CAUTION** DO NOT GET LUBRICANT ON THE SPRING OR CORE IN THE SOLENOID.

**PRECAUCIÓN** NO PERMITA QUE EL LUBRICANTE SE INTRODUZCA EN EL RESORTE O EN EL CORAZÓN DEL SOLENOIDE.

**ATTENTION** FAIRE ATTENTION DE NE PAS RÉPANDRE DE LA GRAISSE SUR LE RESSORT OU LE NOYEAU-PLONGEUR DE L'ÉLECTRO-AIMANT.

- H. Turn valve body over and insert water solenoid sub-assembly into the hole where the water seat is mounted. Carefully twist the solenoid while pressing it into place, so that the o-ring does not get pinched. The terminal block on the side of the solenoid must be on the outside edge of the valve body, turned so that it touches the single solenoid retainer post towards the front of the valve. Hold the solenoid in place until the retainer is firmly mounted.  
I. Place the water solenoid retainer on top of the solenoid and install three (3) screws. The water solenoid sub-assembly must remain firmly seated during installation to avoid damaging the o-ring. Tighten each screw a little at a time, so that the retainer stays perpendicular to the water solenoid.  
J. Install the circuit board.  
K. Reconnect the valve.

## 17. WATER SOLENOID ASSEMBLY

### 17.1 DISASSEMBLY

- A. Remove the core/spring assembly from the solenoid.
- B. Slide the o-ring off the end of the solenoid.
- C. Lift the solenoid washer off the end of the solenoid.

	<p><b>CAUTION</b> THE PLUG NUT MAY PULL OUT OF THE COIL, WHEN TRYING TO LOOSEN. THE COIL CAN BE DAMAGED IF DROPPED.</p>
	<p><b>PRECAUCIÓN</b> LA TUERCA DE LA CLAVIJA PUEDE ZAFARSE DE LA BOBINA, CUANDO SE TRATA DE AFLOJARLA. SI SE CAE LA BOBINA SE PUEDE DAÑAR.</p>
	<p><b>ATTENTION</b> IL SERA POSSIBLE QUE L'ÉCROU DE BLOCAGE DE LA BOBINE SE DÉSOLIDARISE DE CETTE DERNIÈRE LORS DU DESSERRAGE DE L'ENSEMBLE. VEILLER À NE PAS FAIRE TOMBER LA BOBINE, AU RISQUE DE L'ENDOMMAGER.</p>

- D. Carefully hold the wire terminal block on the side of the coil while pulling the solenoid bonnet to loosen the water plug nut. When the water plug nut has been pulled out of the coil enough, remove it and the bonnet by hand.

### 17.2 ASSEMBLY

- A. Slide o-ring into the groove on the water plug nut.
- B. Slide bonnet over coil.
- C. Apply 111 Lubricant to o-ring in plug nut.
- D. Press plug nut into top of coil/bonnet assembly.
- E. Place solenoid washer on bottom end of the coil/bonnet assembly.
- F. Place o-ring over end of coil extending through the solenoid washer.
- G. Insert core/spring assembly into the end of the solenoid assembly.

**NOTE:** Water and syrup solenoid coils are interchangeable.

**FIGURE 20 -WATER SOLENOID ACCESS**

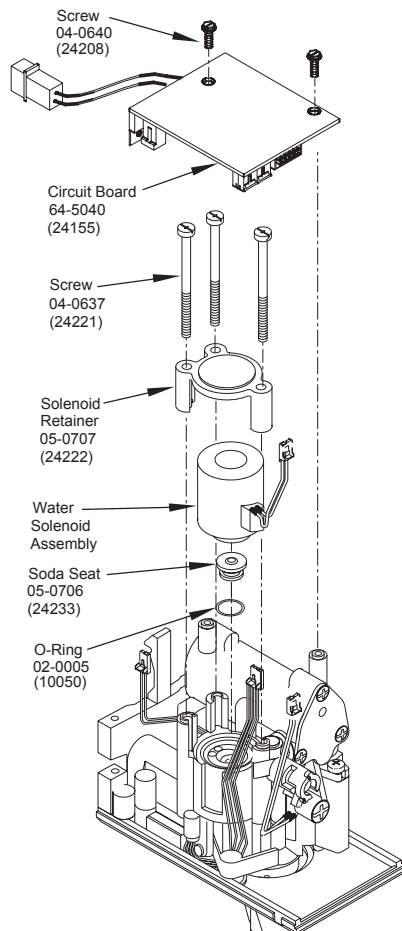

**NOTE:** Part Number in ( ) is a Coca-Cola PN

**FIGURE 21 - WATER SOLENOID ASSEMBLY**

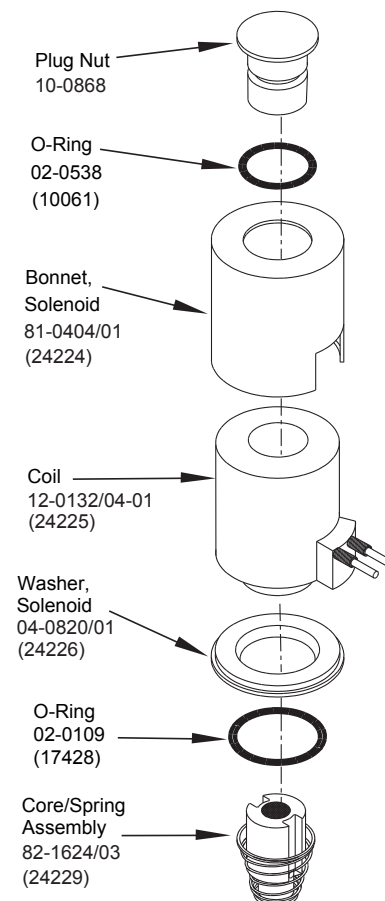

**NOTE:** Part Number in ( ) is a Coca-Cola PN

## 18. SYRUP BODY ACCESS

### 18.1 REMOVAL

- A. Remove valve from back block (see Valve, Section 9).
- B. Remove circuit board (see Circuit Board, Section 12).
- C. Remove nozzle/diffuser (see Nozzle/Diffuser, Section 11).
- D. Remove lever arm, if applicable (see Lever Arm, Section 10).
- E. Remove four (4) screws holding the bottom plate in place.
- F. Pull bottom plate off.
- G. Remove two (2) screws located at front and rear of syrup body.
- H. Turn valve assembly over and remove the two (2) screws on the underside of the main body, holding the syrup body in place.



**CAUTION** PARTS OF THE SYRUP SOLENOIDS MAY FALL OUT WHEN THE SYRUP BODY IS REMOVED.

**PRECAUCIÓN** PARTES DE LOS SOLENOIDES DEL JARABE SE PUEDEN CAER CUANDO SE RETIRA EL CUERPO DEL JARABE.

**ATTENTION** CERTAINS COMPOSANTS DES ÉLECTRO-AIMANTS DU CÔTÉ SIROP POURRONT TOMBER LORSQUE LE CORPS DE LA VANNE SERA DÉPOSÉ.

- I. Lift the syrup body subassembly off of the syrup solenoids.
- J. Pull the syrup down tube restrictor assembly out of the port on the side of the syrup body.

### 18.2 INSTALLATION

- A. If necessary, install an o-ring on either end of the syrup down tube restrictor assembly.
- B. Apply 111 Lubricant around each end of the syrup down tube restrictor, if necessary.
- C. Insert syrup down tube restrictor assembly into port on the side of the syrup body sub-assembly.
- D. Apply 111 Lubricant to the outside edge of o-ring on the syrup solenoids.



**CAUTION** DO NOT GET LUBRICANT ON THE SPRING OR CORE IN THE SOLENOID.

**PRECAUCIÓN** NO PERMITA QUE EL LUBRICANTE SE INTRODUZCA EN EL RESORTE O EN EL CORAZÓN DEL SOLENOIDE.

**ATTENTION** FAIRE ATTENTION DE NE PAS RÉPANDRE DE LA GRAISSE SUR LE RESSORT OU LE NOYEAU-PLONGEUR DE L'ÉLECTRO-AIMANT.

- E. Rotate the front syrup solenoid until its terminal block rests in groove, towards the syrup down tube port.
- F. Rotate the back syrup solenoid, so that its terminal block rests against the water solenoid retainer mount.



**CAUTION** SYRUP SOLENOIDS MUST BE SEATED AGAINST MAIN BODY. IF SOLENOIDS BECOME UNSEATED, SEE SYRUP SOLENOID ACCESS, INSTALLATION, SECTION 19.

**PRECAUCIÓN** LOS SOLENOIDES DEL JARABE DEBEN ESTAR ASENTADOS CONTRA EL CUERPO PRINCIPAL. SI LOS SOLENOIDES NO ESTÁN ASENTADOS, VEA EN LA SECCIÓN 19 DE LA INSTALACIÓN EL ACCESO A LOS SOLENOIDES DE

**ATTENTION** LES ÉLECTRO-AIMANTS DU CÔTÉ SIROP DEVRONT RESTER PLAQUÉS CONTRE LE CORPS PRINCIPAL. SI LES ÉLECTRO-AIMANTS SORTENT DE LEUR SIÈGE, CONSULTEZ LES INSTRUCTIONS RELATIVES À LEUR ACCÈS ET MONTAGE CONTENUES DANS LA SECTION 19.

- G. Carefully press the syrup body sub-assembly into place on top of the syrup solenoids. If the syrup body will not smoothly press into place, then apply more 111 Lubricant to the solenoid o-rings, so that they will not be pinched.
  1. Make certain the syrup down tube restrictor assembly goes into the down tube port on the valve body.
  2. Hold the syrup body firmly in place until the mounting screws are completely installed.

**NOTE:** Mounting screws must be tight. Loose screws will cause leaks and alter valve performance.
- H. Install screw at front and rear of syrup body.

## 18.2 SYRUP BODY INSTALLATION - CONTINUED

- I. Install two (2) screws on the underside of the main body, to secure syrup body.
- J. Install circuit board (see Circuit Board, Section 12) and secure with two (2) screws.
- K. Place the flowmeter wires around the outside of the flow washer assembly, so that they will not interfere with the bottom plate installation. Connect to circuit board.



**CAUTION** DO NOT PINCH ANY WIRES DURING INSTALL

**PRECAUCIÓN** NO NO PELLIZQUE NINGÚN CABLE DURANTE LA INSTALACIÓN.

**ATTENTION** VEILLER À NE COINCER AUCUN FIL LORS DU MONTAGE.

- L. Line up holes on the bottom plate with the screw holes on the underside of the valve body.
- M. Secure bottom plate with four (4) screws.
- N. Install nozzle/diffuser
- O. Install lever arm, if applicable.

**FIGURE 22 - SYRUP BODY ACCESS**

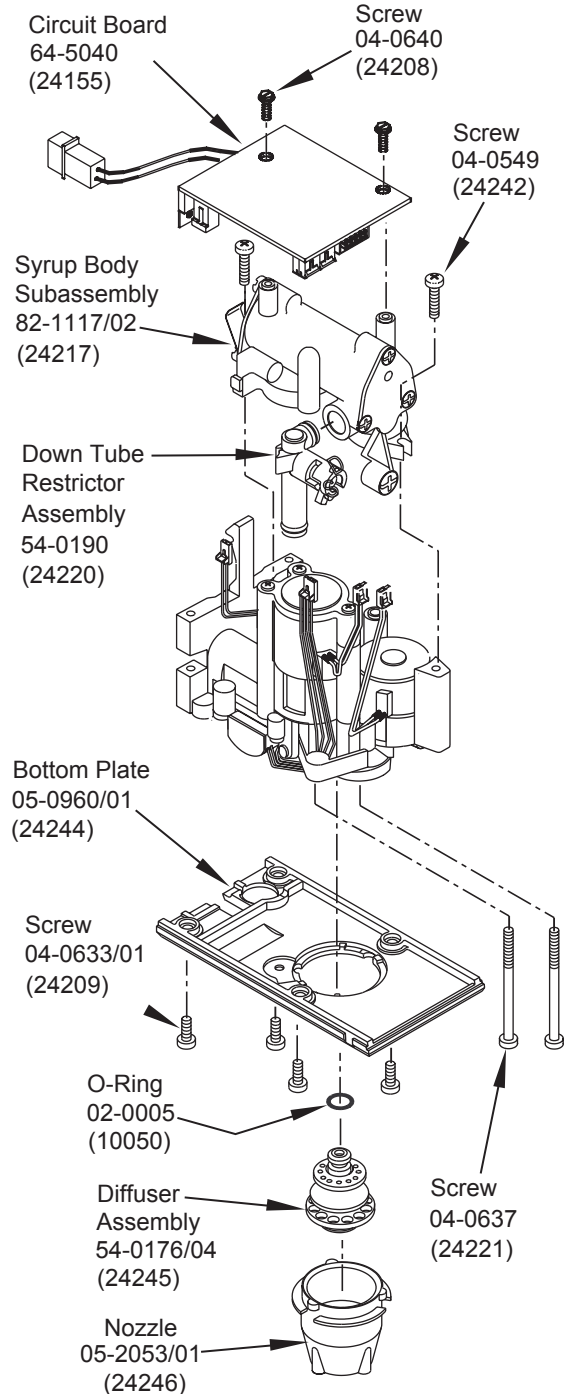

## 19. SYRUP SOLENOID ACCESS

### 19.1 REMOVAL

- Remove valve from back block (see Valve, Section 9).
- Remove circuit board (see Circuit Board, Section 12).
- Remove nozzle/diffuser (see Nozzle/ Diffuser, Section 11).
- Remove lever arm, if applicable (see Lever Arm, Section 10).
- Remove four (4) screws holding the bottom plate in place.
- Pull bottom plate off.
- Remove the two (2) screws that hold the syrup body in place.
- Turn valve assembly over and remove the two (2) screws, on the underside of the main body, holding the syrup body in place.
- Lift the syrup body off of the syrup solenoids.

**CAUTION** PARTS OF THE SYRUP SOLENOIDS MAY FALL OUT WHEN THE SYRUP BODY IS REMOVED.

**PRECAUCIÓN** PARTES DE LOS SOLENOIDES DEL JARABE SE PUEDEN CAER CUANDO SE RETIRA EL CUERPO DEL JARABE.

**ATTENTION** CERTAINS COMPOSANTS DES ÉLECTRO-AIMANTS DU CÔTÉ SIROP POURRONT TOMBER LORSQUE LE CORPS DE LA VANNE SERA DÉPOSÉ.

- Lift each syrup solenoid out of the valve.

**NOTE:** The o-ring mounted under neath the solenoid may stick to the solenoid when it is removed.

### 19.2 INSTALLATION

- Install an o-ring over the port in the bottom of each syrup solenoid mounting area on the main body. Ensure that o-ring seats to bottom of mounting port.
- Apply 111 Lubricant to the outside edges of the o-rings.
- Insert syrup solenoid sub-assembly into the rear mounting area on the main body. Twist the solenoid while pushing it into place to avoid pinching the o-ring at the bottom of the mounting area. Turn the solenoid, so that the terminal block rests against the water solenoid retainer post.
- Insert syrup solenoid sub-assembly into the front mounting area on the main body. Twist the solenoid while pushing it into place to avoid pinching the o-ring at the bottom of the mounting area. Turn the solenoid so that the terminal block rests in groove towards, but not over, the syrup down tube port.
- Apply 111 Lubricant around each of the o-rings on the syrup down tube.

**CAUTION** DO NOT GET LUBRICANT ON THE SPRING OR CORE IN THE SOLENOID.

**PRECAUCIÓN** NO PERMITA QUE EL LUBRICANTE SE INTRODUZCA EN EL RESORTE O EN EL CORAZÓN DEL SOLENOIDE.

**ATTENTION** FAIRE ATTENTION DE NE PAS RÉPANDRE DE LA GRAISSE SUR LE RESSORT OU LE NOYEAU-PLONGEUR DE L'ÉLECTRO-AIMANT.

FIGURE 23 - SYRUP SOLENOID ACCESS

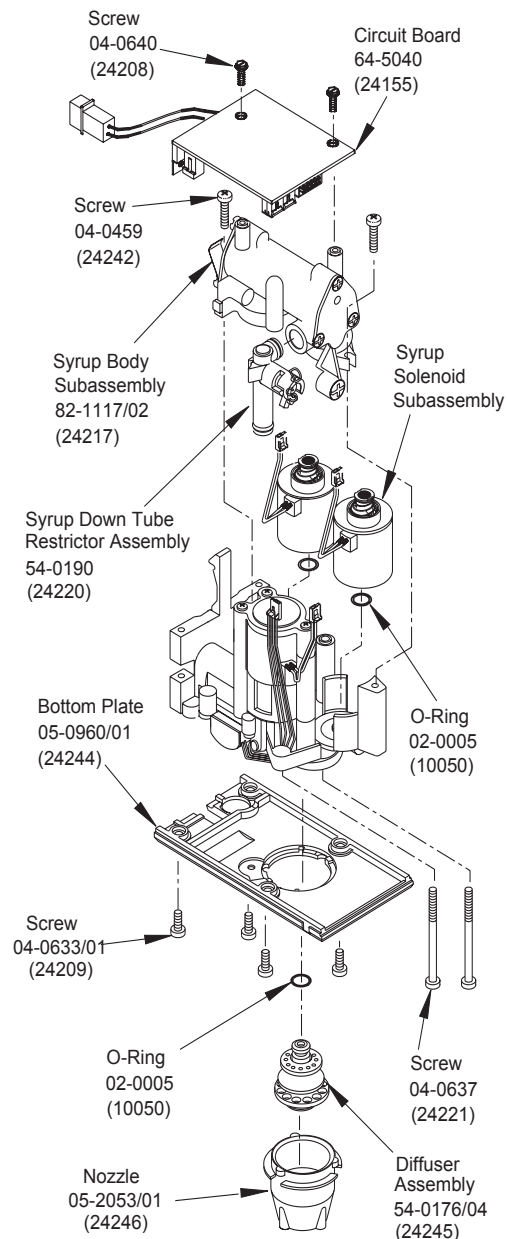

## 19.2 SYRUP SOLENOID INSTALLATION - CONTINUED

- F. Insert syrup down tube into port on the side of the syrup body sub-assembly.
- G. Apply 111 Lubricant to the outside edge of o-ring on the syrup solenoids.
- H. Carefully press the syrup body sub-assembly into place on top of the syrup solenoids. If the syrup body will not smoothly press into place, then apply more 111 Lubricant to the solenoid o-rings, so that they will not be pinched. Make certain the syrup down tube goes into the down tube port on the valve body. If the solenoid assembly becomes unseated, remove solenoid assembly and repeat Steps A through D above. Hold the syrup body firmly in place until the mounting screws are completely installed.
- I. Install two (2) upper screws located at front and rear of syrup body.
- J. Install two (2) screws on the underside of main body, to secure the syrup body.
- K. Place the flowmeter wires around the outside of the flow washer assembly, so that they will not interfere with the bottom plate installation.

	<b>CAUTION</b> DO NOT PINCH ANY WIRES DURING INSTALL
	<b>PRECAUCIÓN</b> NO NO PELLIZQUE NINGÚN CABLE DURANTE LA INSTALACIÓN.
	<b>ATTENTION</b> VEILLER À NE COINCER AUCUN FIL LORS DU MONTAGE.

- L. Line up holes on the bottom plate with the screw holes on the underside of the main body.
- M. Secure bottom plate in place with four (4) screws.
- N. Install nozzle/diffuser
- O. Install lever arm, if applicable.
- P. Install circuit board (see Circuit Board, Section 12).

**FIGURE 24 - SYRUP SOLENOID ASSEMBLY**

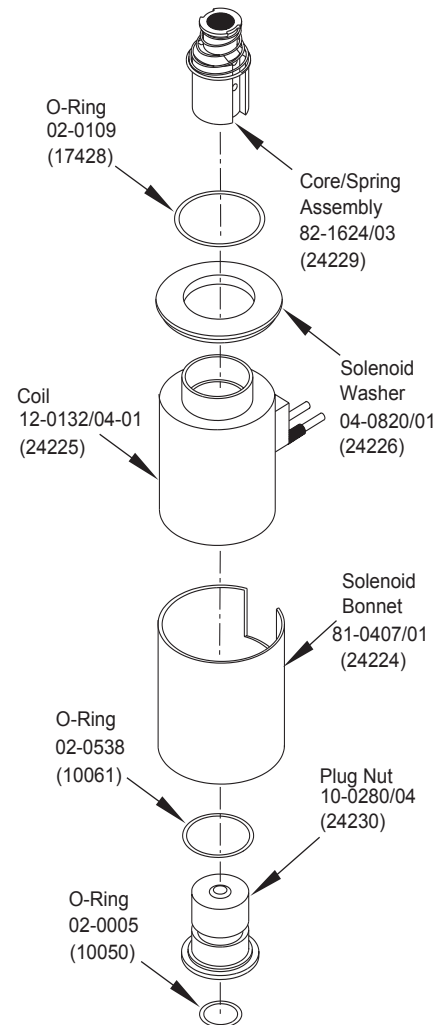

## 20. SYRUP SOLENOID ASSEMBLY

### 20.1 DISASSEMBLY

- A. Remove the core/spring assembly from the solenoid.
- B. Slide the o-ring off the end of the solenoid.
- C. Lift the solenoid washer off the end of the solenoid.
- D. If the o-ring remains in the end of the syrup plug nut or on the post inside the syrup solenoid mounting area on the main body, remove it.

	<b>CAUTION</b> THE PLUG NUT MAY PULL OUT OF THE COIL, WHEN TRYING TO LOOSEN. THE COIL CAN BE DAMAGED IF DROPPED.
	<b>PRECAUCIÓN</b> LA TUERCA DE LA CLAVIJA PUEDE ZAFARSE DE LA BOBINA, CUANDO SE TRATA DE AFLOJARLA. SI SE CAE LA BOBINA SE PUEDE DAÑAR,
	<b>ATTENTION</b> IL SERA POSSIBLE QUE L'ÉCROU DE BLOCAGE DE LA BOBINE SE DÉSDOLIDARISE DE CETTE DERNIÈRE LORS DU DESSERRAGE DE L'ENSEMBLE. VEILLER À NE PAS FAIRE TOMBER LA BOBINE, AU RISQUE DE L'ENDOMMAGER.

- E. Carefully hold the wire terminal block on the side of the coil while pulling the solenoid bonnet to loosen the syrup plug nut. When the syrup plug nut has been pulled out of the coil enough, remove it and the bonnet by hand.

### 20.2 ASSEMBLY

- A. Slide o-ring into the groove on the syrup plug nut.
- B. Slide bonnet over coil.
- C. Apply 111 Lubricant to o-ring in plug nut, then press plug nut into top of coil/bonnet assembly.
- D. Place solenoid washer on bottom end of coil/bonnet assembly.
- E. Place o-ring over end of coil extending through solenoid washer.
- F. Insert the core/spring assembly into the end of the solenoid assembly.

**NOTE:** Water and syrup solenoid coils are interchangeable.

## 21. TROUBLESHOOTING

SYMPTOM	POSSIBLE CAUSE	VERIFICATION	SOLUTION
<p>Drink Ratio Incorrect (Weak or Strong); Programmer available</p>	<p>A. Syrup restrictor incorrectly set.</p> <p>B. Flow washer bad (if installed).</p> <p>C. Insufficient syrup pressure.</p> <p>D. Syrup obstructed.</p> <p>E. Incorrect ratio setting in memory.</p> <p>F. Flowmeter malfunctioning.</p>	<p>A. Check location of restrictor. Restrictor must be in and up for diet bag-in-box (BIB) applications, directly above the letter 'D' in the syrup down tube assembly. Restrictor must be down and out for non-diet drinks, directly below the letter "S" in the syrup down tube assembly.</p> <p>B. Water flow over 2.7 oz/sec on a timed pour.</p> <p>C. Run syrup purge test on hand held programmer. Output syrup should be approx. 3 oz.</p> <p>D. Incorrect ratio measurement after circuit board replaced.</p> <p>E1. Plug in programmer and press 'Read Memory', and ratio and/ or carbonation setting incorrect.</p> <p>E2. Reprogramming of ratio and/or carbonation setting does not work.</p> <p>F. All other items above checked.</p>	<p>A. Position restrictor correctly.</p> <p>B. Replace flow washer assembly, or install one if needed.</p> <p>C. Increase dispensing system syrup pressure.</p> <p>D. Disassemble syrup side and remove obstruction.</p> <p>E1. Reprogram valve's memory by using "+/- keys, Carb Toggle and 'Write Memory'.</p> <p>E2. Replace circuit board.</p> <p>F. Replace flowmeter assembly</p>
<p>Drink Ratio Incorrect Weak or Strong); Programmer unavailable</p>	<p>A. Syrup restrictor incorrectly set.</p> <p>B. Flow washer bad (if installed)</p> <p>C. Insufficient syrup pressure.</p> <p>D. Syrup obstructed. side and remove obstruction.</p> <p>E. Flowmeter malfunctioning</p>	<p>A. Check location of restrictor. Restrictor must be in and up for diet bag-in-box (BIB) applications, directly above the letter "D" in the syrup down tube assembly.</p> <p>B. Water flow over 2.7oz/sec on a timed pour. Flow washer installed correctly.</p> <p>C. Run syrup purge test on hand held programmer. Output syrup should be approx. 3 oz.</p> <p>D. Incorrect ratio measurement after circuit board replaced.</p> <p>E. All other items above checked.</p>	<p>A. Position restrictor correctly.</p> <p>B. Replace flow washer assembly, or install one if needed.</p> <p>C. Increase dispensing system syrup pressure.</p> <p>D. Disassemble syrup side and remove obstruction.</p> <p>E. Replace flowmeter assembly.</p>

SYMPTOM	POSSIBLE CAUSE	VERIFICATION	SOLUTION
Nothing Dispenses When Valve Activated	<p>A. Circuit Board malfunctioning</p> <p>B. Soda &amp; front syrup solenoid wires plugged into wrong connector.</p> <p>C. Water solenoid malfunctioning.</p> <p>D. Water Solenoid Core defective</p> <p>E. Circuit board malfunctioning.</p> <p>F. Circuit board misaligned. Lever not making contact with circuit board sensor.</p>	<p>A. Programmer does not light up 24 volt supply connected. NOTE: For Valves made on/after Nov 2011, the amber (orange) LED does not light up AND the 24 VOLT supply is connected.</p> <p>B. '5 sec water' button on programmer dispenses small amount of syrup. Green and red LEDs light up.</p> <p>C. Programmer lights up, but does not dispense water with '5 sec water'. Shut-offs are open. Green LED lights up.</p> <p>D. Rubber poppet in core is swollen or deformed. Green LED lights up.</p> <p>E. New ratio cannot be entered w/ programmer.</p> <p>F. Circuit board not screwed all the way down. Board misaligned with holes and mounting posts.</p>	<p>A. Check fuser, or replace circuit board.</p> <p>B. Connect soda and front syrup to correct connectors.</p> <p>C. Replace water solenoid.</p> <p>D. Replace core.</p> <p>E. Replace circuit board.</p> <p>F. Ensure board is aligned &amp; screw in board all the way down.</p>
Valve Dispenses Water Only	<p>A. Syrup shut-off on back block is closed.</p> <p>B. Out of syrup.</p> <p>C. Syrup solenoid unplugged.</p> <p>D. Flowmeter unplugged.</p> <p>E. Flowmeter connector wet.</p> <p>F. Circuit board malfunctioning.</p> <p>G. Flowmeter rotor obstructed, does not turn freely.</p> <p>H. Bad Flowmeter Sensor.</p> <p>I. Bad Syrup Solenoid.</p> <p>J. Syrup solenoid core is defective.</p> <p>K. Syrup side of valve obstructed.</p>	<p>A. Coils click when activated by programmer 'syrup purge'. Green &amp; Red LEDs light up.</p> <p>B. Syrup purge draws no syrup &amp; shut-off is open.</p> <p>C. No clicking sound when 'syrup purge' activated.</p> <p>D. Flow rates (0) after programmer '5 sec water' pour. Green LED lights up.</p> <p>E. Flow rate zero (0) after programmer '5 sec water' pour. Circuit board wet. No LEDs light up.</p> <p>F. Programmer does not light up when plugged in.</p> <p>G. Flow rate zero (0) after programmer '5 sec water' pour.</p> <p>H. Flow rate zero (0) after programmer '5 sec water' pour. Green LED lights up.</p> <p>I. No clicking sound when 'syrup purge' activated &amp; coils properly connected. Green &amp; Red LEDs light up.</p> <p>J. Rubber poppet in core is swollen or deformed.</p> <p>K. Coils click when "syrup purge" activated, shut-off is open, and syrup supply is full. Green &amp; Red LEDs light up.</p>	<p>A. Open syrup shut-off on mounting block.</p> <p>B. Replace BIB or final.</p> <p>C. Plug in syrup solenoid.</p> <p>D. Plug in flowmeter connector.</p> <p>E. Unplug. Dry connector. Shake water out of plug.</p> <p>F. Replace circuit board.</p> <p>G. Remove obstruction or replace flowmeter.</p> <p>H. Replace flowmeter assembly.</p> <p>I. Replace syrup solenoid.</p> <p>J. Replace core.</p> <p>K. Disassemble syrup side &amp; remove obstruction.</p>

<b>SYMPTOM</b>	<b>POSSIBLE CAUSE</b>	<b>VERIFICATION</b>	<b>SOLUTION</b>
Valve Dispenses without Prompt/ Request	<p>A. Lever arm or lever spring damaged.</p> <p>B. Push Button/ Portion Control malfunctioning.</p> <p>C. Circuit Board malfunctioning.</p> <p>D. Moisture in plug (pushbutton programmer) on front of circuit card.</p>	<p>A. Top end of lever arm does not return to back of valve.</p> <p>B. Valve stops, when panel unplugged from circuit board.</p> <p>C. Valve pours with lever arm retracted, or pushbutton/portion control unplugged.</p> <p>D. Circuit board covered with water</p>	<p>A. Replace lever arm and/or lever spring.</p> <p>B. Replace panel.</p> <p>C. Replace circuit board.</p> <p>D. Unplug. Dry out connector. Shakedown out of plug.</p>
Valve Pours Erratically	<p>A. Connectors loose.</p> <p>B. Pushbutton malfunctioning.</p> <p>C. Connectors wet.</p> <p>D. Circuit board malfunctioning.</p> <p>E. Air in lines.</p>	<p>A. Solenoid, flowmeter, and/or pushbutton connectors not plugged into circuit board completely.</p> <p>B. Valve pours erratically when pushed.</p> <p>C. Circuit board covered with water or syrup.</p> <p>D. Valve pours erratically after pushbutton replaced and connections cleaned.</p> <p>E. Hissing sound heard out of valve.</p>	<p>A. Insert connectors until locking tabs engage.</p> <p>B. Replace pushbutton.</p> <p>C. Unplug all connectors. Dry out and blowdry. Shake water out of plug.</p> <p>D. Replace circuit board.</p> <p>E. Continue to pour until air is purged from lines.</p>
Water Leak	<p>A. Screw(s) loose.</p> <p>B. O-ring seal is bad.</p> <p>C. Flowmeter body is broken.</p> <p>D. Debris in water solenoid.</p> <p>E. Valve body broken.</p>	<p>A. Water solenoid or flowmeter screws turn easily.</p> <p>B. Water leaks past o-ring, after screws have been tightened.</p> <p>C. Crack visible in flowmeter body.</p> <p>D. Water leaks through nozzle.</p> <p>E. Water continues to leak, after items (above) have been checked.</p>	<p>A. Tighten screw(s).</p> <p>B. Replace o-ring.</p> <p>C. Replace flowmeter assembly.</p> <p>D. Remove debris from water solenoid.</p> <p>E. Replace valve.</p>
Syrup Leak	<p>A. Screw(s) loose.</p> <p>B. O-ring seal is bad.</p> <p>C. Syrup body is cracked.</p> <p>D. Debris in syrup solenoid.</p> <p>E. Valve body broken.</p>	<p>A. Syrup body or syrup retainer screws turn easily.</p> <p>B. Syrup leaks past o-ring, after screws have been tightened.</p> <p>C. Crack visible in syrup body.</p> <p>D. Syrup leaks through nozzle.</p> <p>E. Syrup continues to leak, after items (above) have been checked.</p>	<p>A. Tighten screw(s) to 9 inch-pounds.</p> <p>B. Replace o-ring.</p> <p>C. Replace syrup body assembly.</p> <p>D. Remove debris from Syrup Solenoid.</p> <p>E. Replace valve.</p>

## NOTES

### 22. APPLIANCE DISPOSAL



To prevent possible harm to the environment from improper disposal, recycle the unit by locating an authorized recycler or contact the retailer where the product was purchased. Comply with local regulations regarding disposal of the refrigerant and insulation.

### 23. VOLUMETRIC VALVE ASSEMBLY

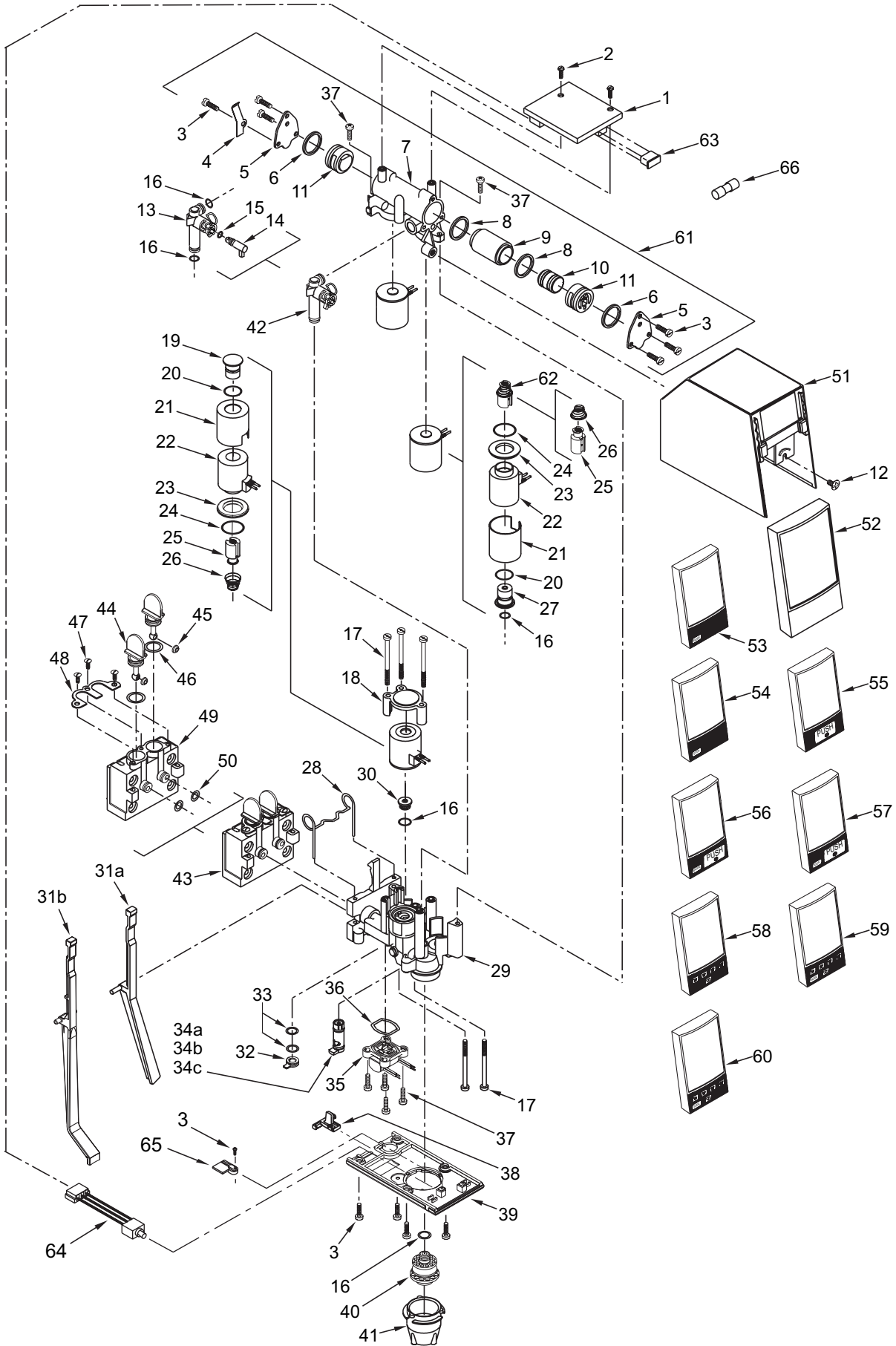

### 23. VOLUMETRIC VALVE PARTS LIST

<u>Item</u>	<u>Part No.</u>	<u>Description</u>	<u>CCUSA</u>	<u>Item</u>	<u>Part No.</u>	<u>Description</u>	<u>CCUSA</u>
R 1	52-2345/05	PCB Assy	24155	R 43	82-0274	Mounting Block	19810
	2	Screw, 4 - 20	24208	R 44	05-0266/01	Valve Stem, Mounting Block	12270
R 3	04-0633/01	Screw, 6 - 19 x 0.437	24209	R 45	05-0267	Washer	12286
	4	Spring, Lever	24210	R 46	02-0047	O-Ring	15175
R 5	03-0187	Retainer, Syrup	24211	R 47	04-0269	Screw	19894
	6	O-Ring	22363	R 48	03-0087	Retainer, Valve,	12263
R 7	54-0115/01	Body Assy, Meter Assy, Syrup	24212	R 48	03-0087	Retainer, Valve, Mounting Block	12263
	8	O-Ring	24213	R 49	05-0265/01	Mounting Block	12189
R 9	81-0298	Sleeve, Syrup	1070147	R 50	02-0126	O-Ring	10706
	10	Piston	24215	R 51	54-0029/02	Cover Sub-assy	23984
R 11	05-0940/02	Retainer, Piston	24216	R 52	05-0287/02	ID Panel	21432
R 12	04-0302	Screw	21691	R 53	52-1571	ID Panel, Water Button	24251
R 13	54-0175	Tube, Down, Syrup, Restrictor		R 54	52-1572	ID Panel, Soda Button	24252
R 14	05-1094	Restrictor, Syrup	24219	R 55	52-1399	ID Panel, Push Button	24253
	15	O-Ring	10060	R 56	52-1573	ID Panel, Push Button, Water	24254
	16	O-Ring	10050	R 57	52-1574	ID Panel, Push Button, Soda	24255
	17	Screw	24221	R 58	52-1575/02	ID Panel, Portion Control,	24256
	18	Retainer, Soda, Solenoid	24222	R 59	52-1576/02	ID Panel, Portion Control,Water	24257
R 19	10-0877/03	Plug Nut, Soda, Solenoid	1071045	R 60	52-1577/02	ID Panel, Portion Control,Soda	24258
R 20	02-0538	O-Ring	10061	R 61	82-1117/02	Meter Assy, Syrup	24217
R 21	81-0289	Bonnet, Sub-assy, Solenoid	24214	R 62	82-1624	Core/Spring Assy (Includes Items 25 & 26)	24229
R 22	12-0132/01-01	Coil	24225	R 63	05-1187	Cover, Programmer Plug	1071044
R 23	04-0600	Washer, Solenoid	24226	R 64	52-2491	Harness Assy,Syrup Purge	
	24	O-Ring	17428	R 65	05-1958	Holder. Purge Switch, Volumetric Valve	
R 25	23-1071	Core Assy	1071046	R 66	12-0348	Fuse, 5 Amp, 5X15, Fast Acting	1070729
R 26	03-0180	Spring, Core	24228	R --	52-1420/02	Hand Held Programmer Assy	532179
R 27	10-0280/02	Plug Nut, Syrup	24230				
	28	Retainer, Valve	24231				
R 29	54-0178	Main Body Assy	24232				
	30	Seat, Soda	24233				
R 31a	54-0125/01	Lever Arm	24234				
R 31b	54-0195	Self-Serve Lever	24235				
	32	Plug, Regulator	24236				
	33	O-Ring	10049				
	34a	Flow Washer Assy, Red, 1.50 Ounces	24237				
	34b	Flow Washer Assy, White, 2.25 Ounces	24238				
	34c	Flow Washer Assy, Gray, 3.00 Ounces	24239				
R 35	54-0126	Meter Assy(Includes #36)					
R 36	02-0354	O-Ring					
	37	Screw, 6 - 19 X 0.625	24242				
R 38*	05-1102	Filler, Plate, Bottom	24243				
R 39	05-0960/01	Plate, Bottom	24244				
R 40	54-0176/01	Diffuser, Body Assy	24245				
R 41	05-2053	Nozzle	24246				
R 42	54-0190	Down Tube, Restrictor Assy	24220				
R 43	82-0274	Mounting Block	19810				

\*Model 150P - Pushbutton only

R in margin indicates change or revision

---

***LANCER***<sup>®</sup>

Lancer Corp.

800-729-1500

Technical Support/Warranty: 800-729-1550

[custserv@lancercorp.com](mailto:custserv@lancercorp.com)

[lancercorp.com](http://lancercorp.com)