



©2004 Lennox Industries Inc.
Dallas, Texas



INSTALLATION INSTRUCTIONS

HPXA19 SERIES UNITS

HEAT PUMP UNITS
504,918M
05/04
Supersedes 03/04

Technical
Publications
Litho U.S.A.

Table of Contents

HPXA19 Outdoor Unit	1
Shipping & Packing List	1
General Information	1
Unit Dimensions	2
Parts Arrangement	3
Setting the Unit	3
Electrical	4
Refrigerant Piping	8
Refrigerant Metering Device	12
Flushing Existing Line Set & Indoor Coil	12
Manifold Gauge Set	14
Service Valves	15
Leak Testing	16
Evacuation	16
Start-Up	17
Charging	17
System Operation	22
Defrost System	24
Maintenance	26
Optional Accessories	27
Homeowner Information	27
Check Points	28

**RETAIN THESE INSTRUCTIONS
FOR FUTURE REFERENCE**

HPXA19 Outdoor Unit

Lennox' HPXA19 outdoor units use R410A which is an ozone friendly HFC refrigerant. This unit must be installed with a matching indoor coil and line set as outlined in the Lennox Engineering Handbook. HPXA19 outdoor units are designed for use in expansion valve (TXV) systems only. They are not designed to be used with other refrigerant flow control devices. The Lennox Engineering Handbook lists indoor TXV kits that must be ordered separately.

Shipping and Packing List

- 1 - Assembled HPXA19 outdoor unit
- 2 - Grommets (for liquid and vapor lines)

Check equipment for shipping damage. If you find any damage, immediately contact the last carrier.

WARNING

Improper installation, adjustment, alteration, service or maintenance can cause property damage, personal injury or loss of life. Installation and service must be performed by a qualified installer or service agency.

IMPORTANT

This unit must be matched with an indoor coil as specified in Lennox' Engineering Handbook. Coils previously charged with R22 must be flushed.

CAUTION

Danger of sharp metallic edges. Can cause injury. Take care when servicing unit to avoid accidental contact with sharp edges.

05/04



General Information

These instructions are intended as a general guide and do not supersede local codes in any way. Consult authorities who have jurisdiction before installation.

WARNING

This product and/or the indoor unit it is matched with may contain fiberglass wool.

Disturbing the insulation during installation, maintenance, or repair will expose you to fiberglass wool dust. Breathing this may cause lung cancer. (Fiberglass wool is known to the State of California to cause cancer.)

Fiberglass wool may also cause respiratory, skin, and eye irritation.

To reduce exposure to this substance or for further information, consult material safety data sheets available from address shown below, or contact your supervisor.

Lennox Industries Inc.
P.O. Box 79990
Dallas, TX 75379-9900

504,918M



Unit Dimensions -- Inches (mm)

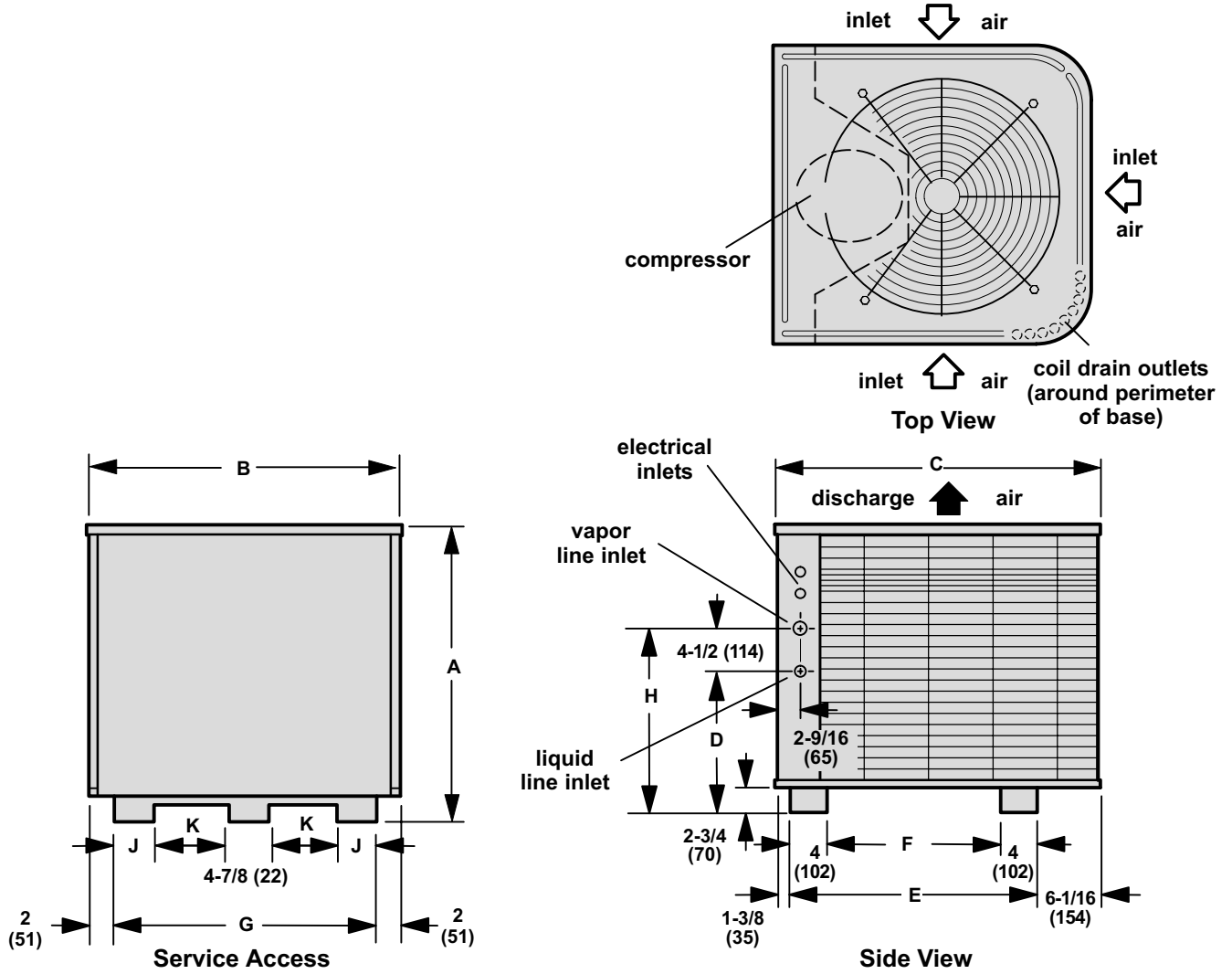

Model No.		A	B	C	D	E	F	G	H	J	K
HPXA19-024	in.	30-7/8	32-1/8	34-1/16	12-3/4	26-5/8	18-5/8	28-1/8	17-1/4	3-7/8	7-1/2
HPXA19-036	mm	784	816	865	324	676	473	718	438	98	191
HPXA19-038	in.	44-7/8	32-1/8	34-1/16	14-1/4	26-5/8	18-5/8	28-1/8	18-3/4	3-7/8	7-1/2
HPXA19-048											
HPXA19-060	mm	1140	816	865	362	676	473	718	476	98	191

Parts Arrangement

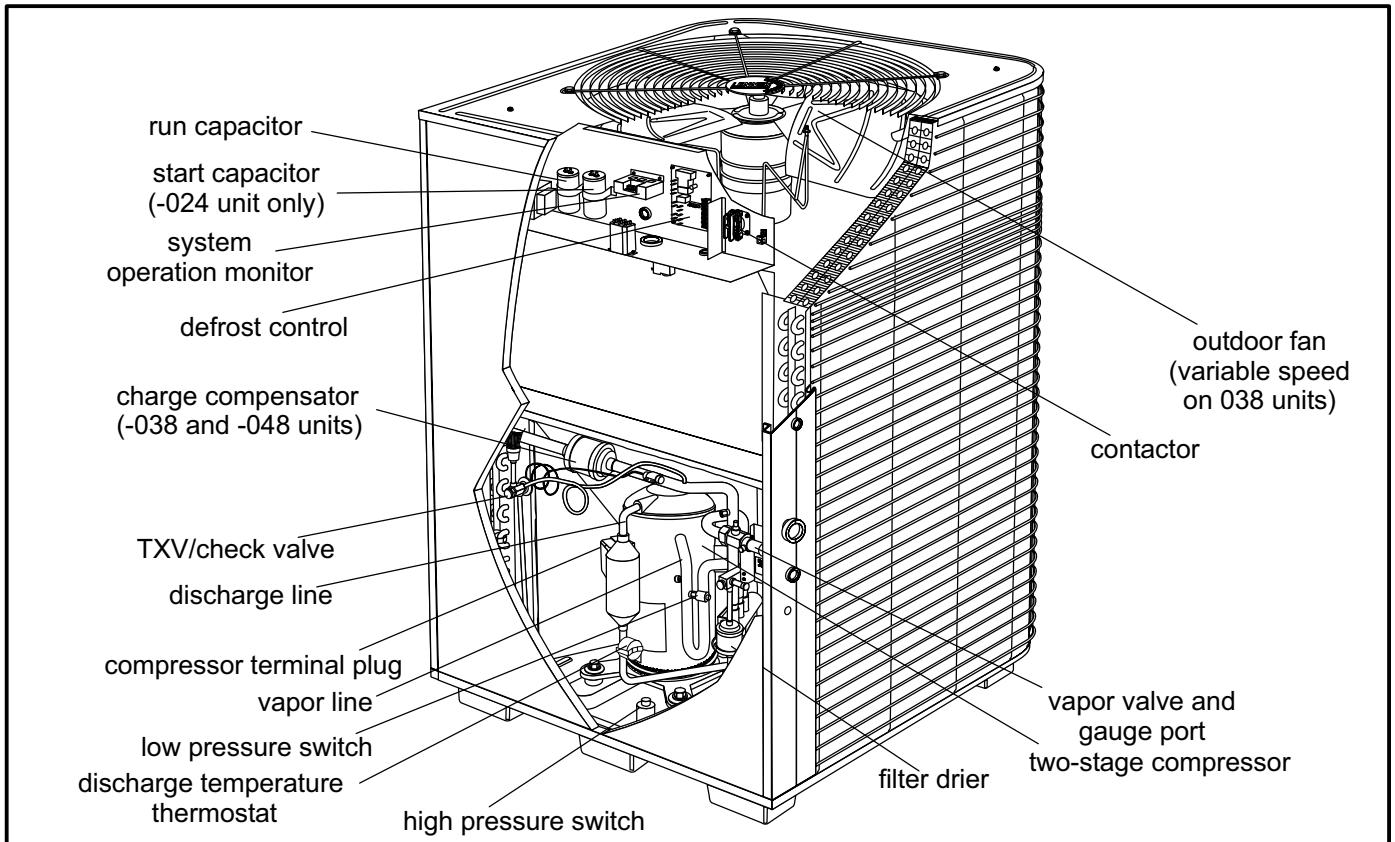

Figure 1

Setting the Unit

CAUTION

In order to avoid injury, take proper precaution when lifting heavy objects.

These units operate under a wide range of weather conditions; therefore, several factors must be considered when positioning the outdoor unit. The unit must be positioned to give adequate clearances for sufficient airflow and servicing. Refer to figure 2 for installation clearances.

- 1 - Place a sound-absorbing material, such as Isomode, under the unit if it will be installed in a location or position that will transmit sound or vibration to the living area or adjacent buildings.
- 2 - Mount unit high enough above ground or roof to allow adequate drainage of defrost water and prevent ice build-up.
- 3 - In heavy snow areas, do not locate unit where drifting will occur. The unit base should be elevated above the depth of average snows.

NOTE - Elevation of the unit may be accomplished by constructing a frame using suitable materials. If a support frame is constructed, it must not block drain holes in unit base.

Installation Clearances

NOTE - A service access clearance of 30" (762 mm) must be maintained in front of the service access panel. Clearance to one side must be 36" (914 mm). Clearance to one of the remaining two sides may be 12" (305 mm), and the final side may be 6" (152 mm).

NOTE - A clearance of 24" (610 mm) must be maintained between two units.

NOTE - 48" (1219 mm) clearance required on top of unit. Maximum soffit overhang is 36" (914 mm).

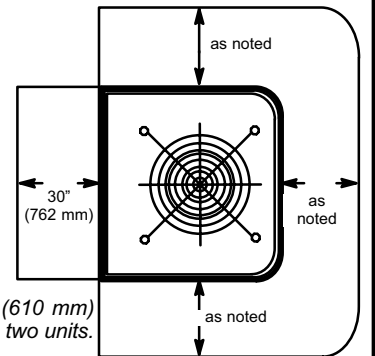

Figure 2

- 4 - When installed in areas where low ambient temperatures exist, locate unit so winter prevailing winds do not blow directly into outdoor coil.
- 5 - Locate unit away from overhanging roof lines which would allow water or ice to drop on, or in front of, coil or into unit.

Slab Mounting

When installing unit at grade level, top of slab should be high enough above the grade so that water from higher ground will not collect around unit. See figure 3. Slab should have a slope tolerance away from the building of 2 degrees or 2 inches per 5 feet (51 mm per 1.5 m). This will prevent ice build-up under unit during a defrost cycle. Refer to roof mounting section for barrier construction if unit must face prevailing winter winds.

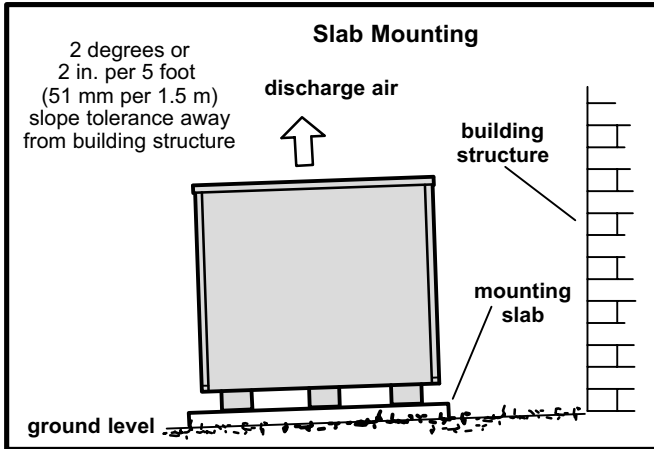

Figure 3

Roof Mounting

Install the unit a minimum of 6 inches (152 mm) above the roof surface to avoid ice build-up around the unit. Locate the unit above a load bearing wall or area of the roof that can adequately support the unit. Consult local codes for rooftop applications.

If unit coil cannot be mounted away from prevailing winter winds, a wind barrier should be constructed. See figure 4. Size barrier at least the same height and width as outdoor unit. Mount barrier 24 inches (610 mm) from the sides of the unit in the direction of prevailing winds.

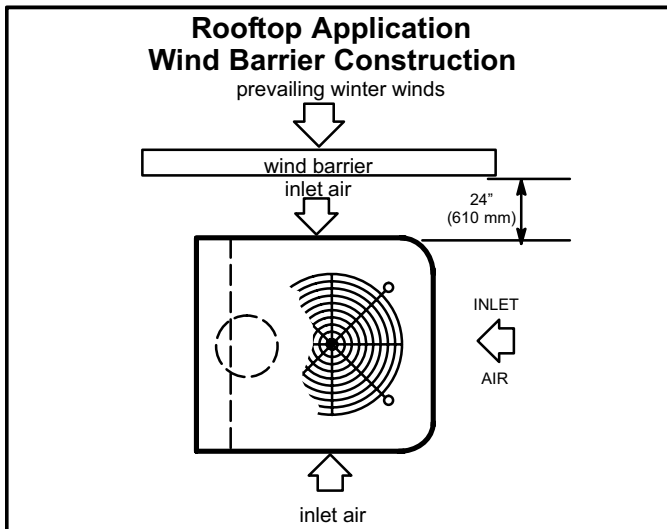

Figure 4

Electrical

In the U.S.A., wiring must conform with current local codes and the current National Electric Code (NEC). In Canada, wiring must conform with current local codes and the current Canadian Electrical Code (CEC).

Refer to the furnace or blower coil installation instructions for additional wiring application diagrams and refer to unit nameplate for minimum circuit ampacity and maximum overcurrent protection size.

⚠ WARNING



Electric shock hazard. May cause injury or death. Line voltage is present at all components when unit is not in operation on units with single pole contactors. Disconnect all remote electric power supplies before opening this panel. Unit may have multiple power supplies.

⚠ WARNING

Unit must be grounded in accordance with national and local codes. Electric Shock Hazard. Can cause injury or death.

- 1 - Install line voltage power supply to unit from a properly sized disconnect switch.
- 2 - Ground unit at unit disconnect switch or to an earth ground.

NOTE - Connect conduit to the unit using a proper conduit fitting.

NOTE - Units are approved for use only with copper conductors.

Refer to figure 5 for high voltage field wiring diagram.

NOTE - A complete unit wiring diagram is located inside the unit's access door.

- 3 - Install room thermostat (ordered separately) on an inside wall approximately in the center of the conditioned area and 5 feet (1.5 m) from the floor. It should not be installed on an outside wall or where it can be effected by sunlight, drafts or vibrations.
- 4 - Install low voltage wiring from outdoor to indoor unit and from thermostat to indoor unit. See figure 8 or 9. *NOTE - 24V, Class II circuit connections are made in the low voltage junction box.*

Typical Field Wiring Diagram

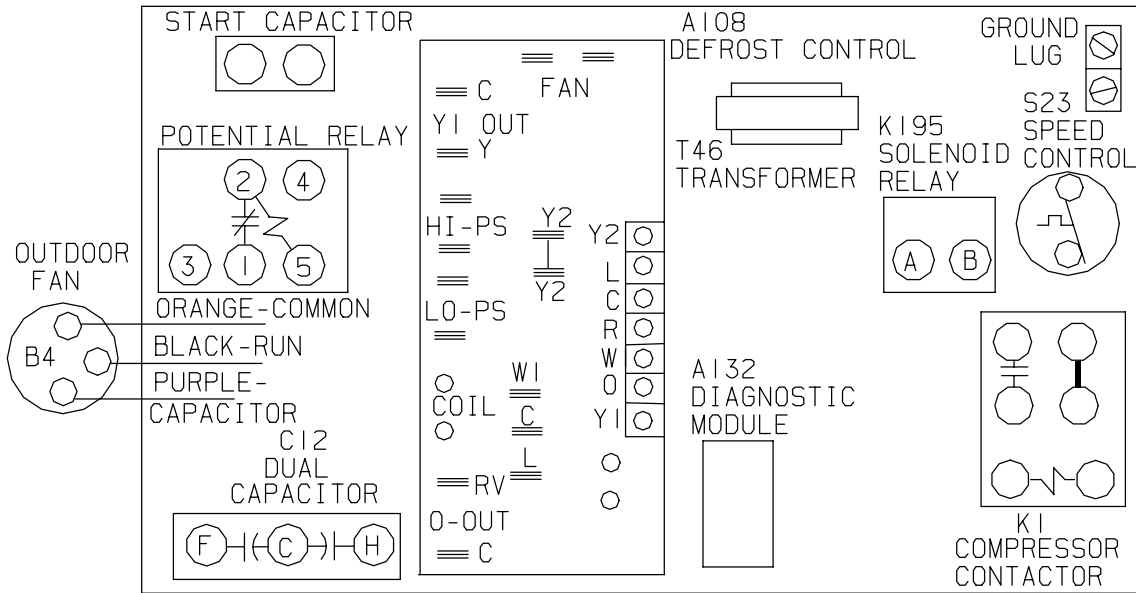

Figure 5

Outdoor Unit and Blower Unit Thermostat Designations

(Some connections may not apply.)

Refer to specific thermostat and indoor unit.)

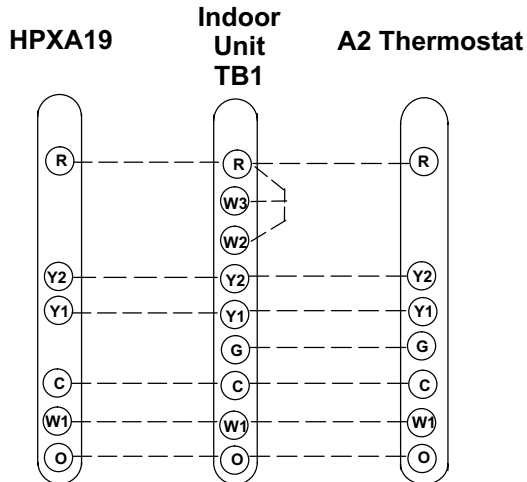

Figure 6

Outdoor Unit and CB31MV/CB32MV Thermostat Designations

(Some connections may not apply.)

Refer to specific thermostat and indoor unit.)

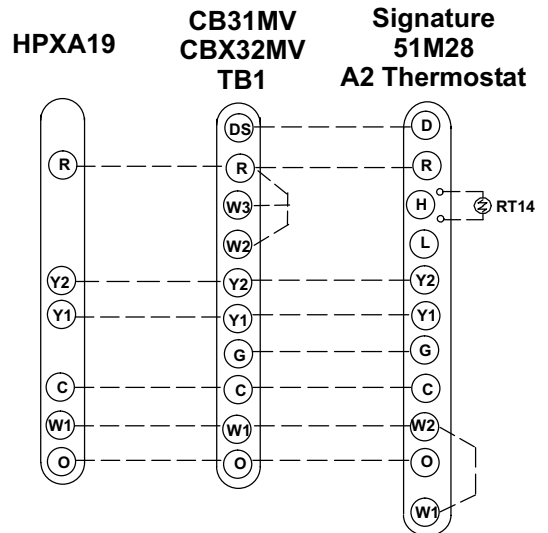

Figure 7

HPXA19-024, -036, -048, and -060 Wiring Diagram

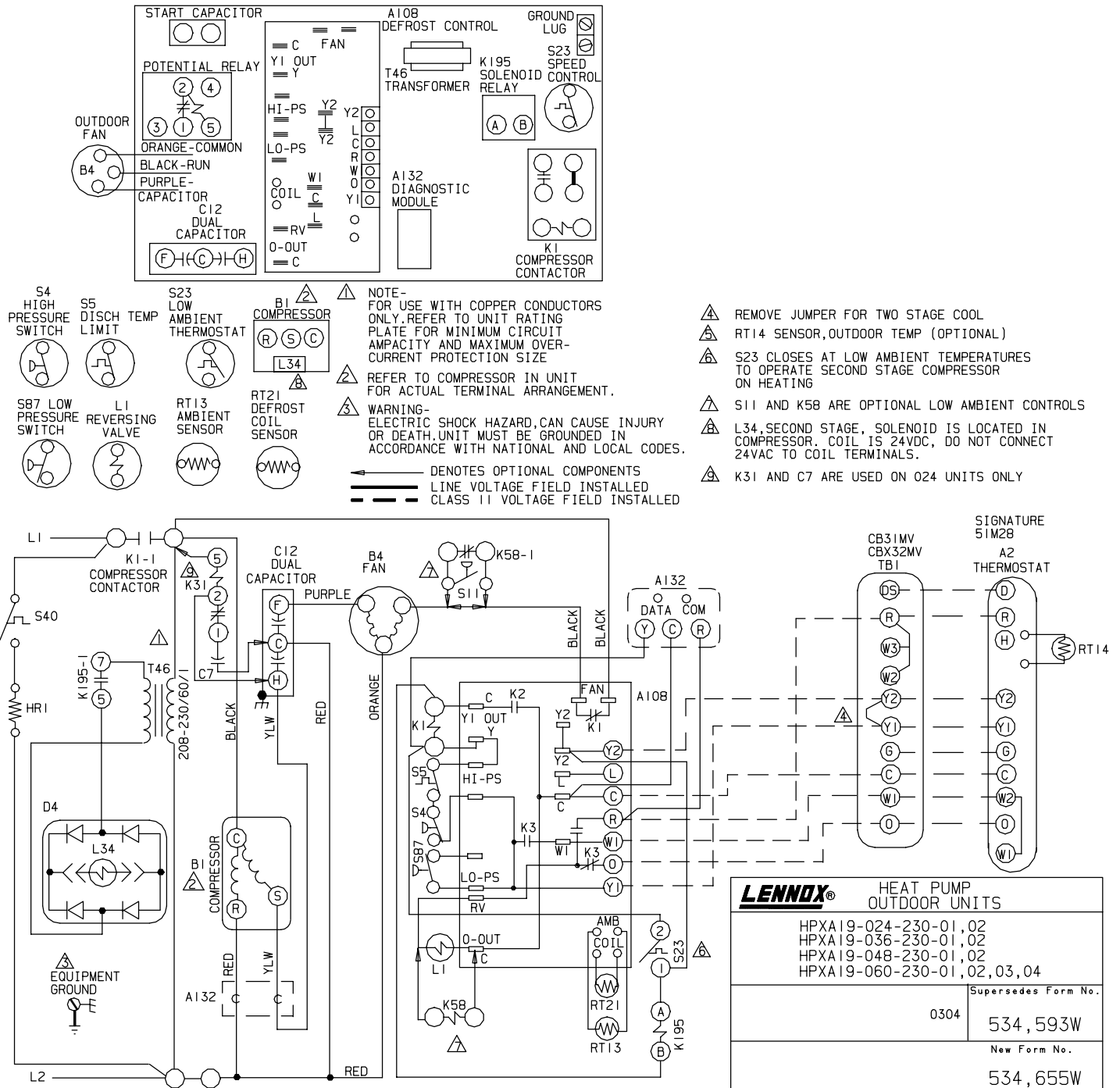
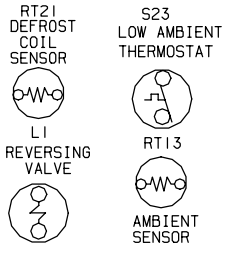
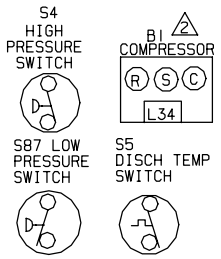
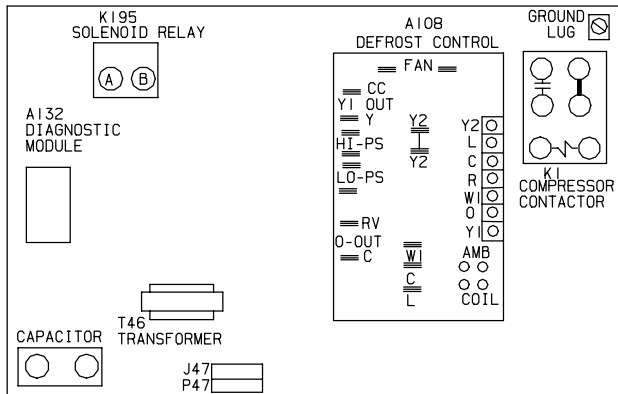

Figure 8

HPXA19-038 Wiring Diagram



NOTE - FOR USE WITH COPPER CONDUCTORS ONLY. REFER TO UNIT RATING PLATE FOR MINIMUM CIRCUIT AMPACITY AND MAXIMUM OVER-CURRENT PROTECTION SIZE.

REFER TO COMPRESSOR IN UNIT FOR ACTUAL TERMINAL ARRANGEMENT.

WARNING - ELECTRIC SHOCK HAZARD, CAN CAUSE INJURY OR DEATH. UNIT MUST BE GROUNDED IN ACCORDANCE WITH NATIONAL AND LOCAL CODES.

REMOVE JUMPER FOR TWO STAGE COOL.

RT14 SENSOR, OUTDOOR TEMP (OPTIONAL)

S23 CLOSURES AT LOW AMBIENT TEMPERATURES TO OPERATE SECOND STAGE COMPRESSOR ON HEATING.

L34 SOLENOID IS LOCATED IN COMPRESSOR, COIL IS 24VDC, DO NOT CONNECT 24VAC TO COIL TERMINALS.

S11, K159 AND K58 ARE OPTIONAL LOW AMBIENT CONTROLS.

SIGNATURE 51M28

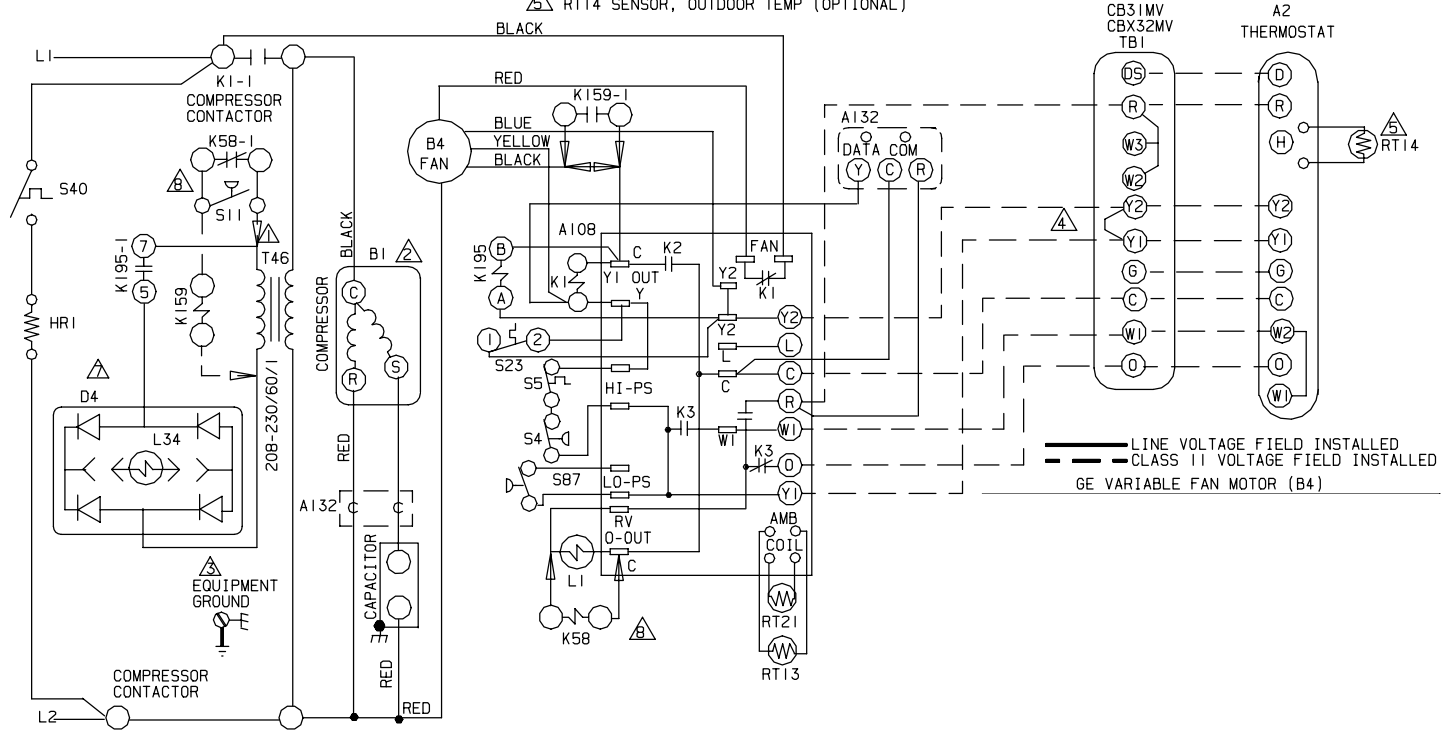

Figure 9

Refrigerant Piping

If the HPXA19 unit is being installed with a new indoor coil and line set, the refrigerant connections should be made as outlined in this section. If an existing line set and/or indoor coil is going to be used to complete the HPXA19 system, refer to the following section which includes flushing procedures.

Field refrigerant piping consists of liquid and vapor lines from the outdoor unit (sweat connections) to the indoor coil (flare or sweat connections). Use Lennox L15 (sweat, non-flare) series line sets as shown in table 1 or use field-fabricated refrigerant lines. Valve sizes are also listed in table 1.

Refrigerant Connections

HPXA19 Matched with New Indoor Coil and Line Set
If an existing indoor coil which was equipped with an RFCI metering device is being replaced, the liquid line must also be replaced prior to the installation of the HPXA19 unit.

Table 1
Refrigerant Line Sets

Model	Valve Field Size Connections		Recommended Line Set		
	Liquid Line	Vapor Line	Liquid Line	Vapor Line	L15 Line Sets
-024 -036	3/8 in. 10 mm	7/8 in. 22 mm	3/8 in. 10 mm	7/8 in. 19 mm	L15-65 15 ft. - 50 ft. 4.6 m - 15 m
-038	3/8 in. 10 mm	7/8 in. 22 mm	3/8 in. 10 mm	7/8 in. 22 mm	L15-65 15 ft. - 50 ft. 4.6 m - 15 m
-048	3/8 in. 10 mm	7/8 in. 22 mm	3/8 in. 10 mm	7/8 in. 22 mm	L15-65 15 ft. - 50 ft. 4.6 m - 15 m
-060	3/8 in. 10 mm	1-1/8 in. 29 mm	3/8 in. 10 mm	1-1/8 in. 29 mm	Field Fabricated

NOTE - Units are designed for line sets of up to 50 feet (15 m).

Installing Refrigerant Line

During the installation of any heat pump or a/c system, it is important to properly isolate the refrigerant lines to prevent unnecessary vibration. Line set contact with the structure (wall, ceiling or floor) causes some objectionable noise when vibration is translated into sound. As a result, more energy or vibration can be expected. Closer attention to line set isolation must be observed.

Following are some points to consider when placing and installing a high-efficiency outdoor unit:

- 1- Placement** - Be aware some localities are adopting sound ordinances based on how noisy the unit is at the neighbors' home, not at the original installation. Install the unit as far as possible from the property line. When possible, do not install the unit directly outside a bedroom window. Glass has a very high level of sound transmission.
- 2- Line Set Isolation** - The following illustrations demonstrate procedures which ensure proper refrigerant line set isolation. Figure 10 shows how to install line sets on vertical runs. Figure 11 shows how to install line sets on horizontal runs. Figure 12 shows how to make a transition from horizontal to vertical. Finally, figure 13 shows how to place the outdoor unit and line set.

**Refrigerant Line Sets
Installing Vertical Runs
(new construction shown)**

NOTE - Similar installation practices should be used if line set is to be installed on exterior of outside wall.

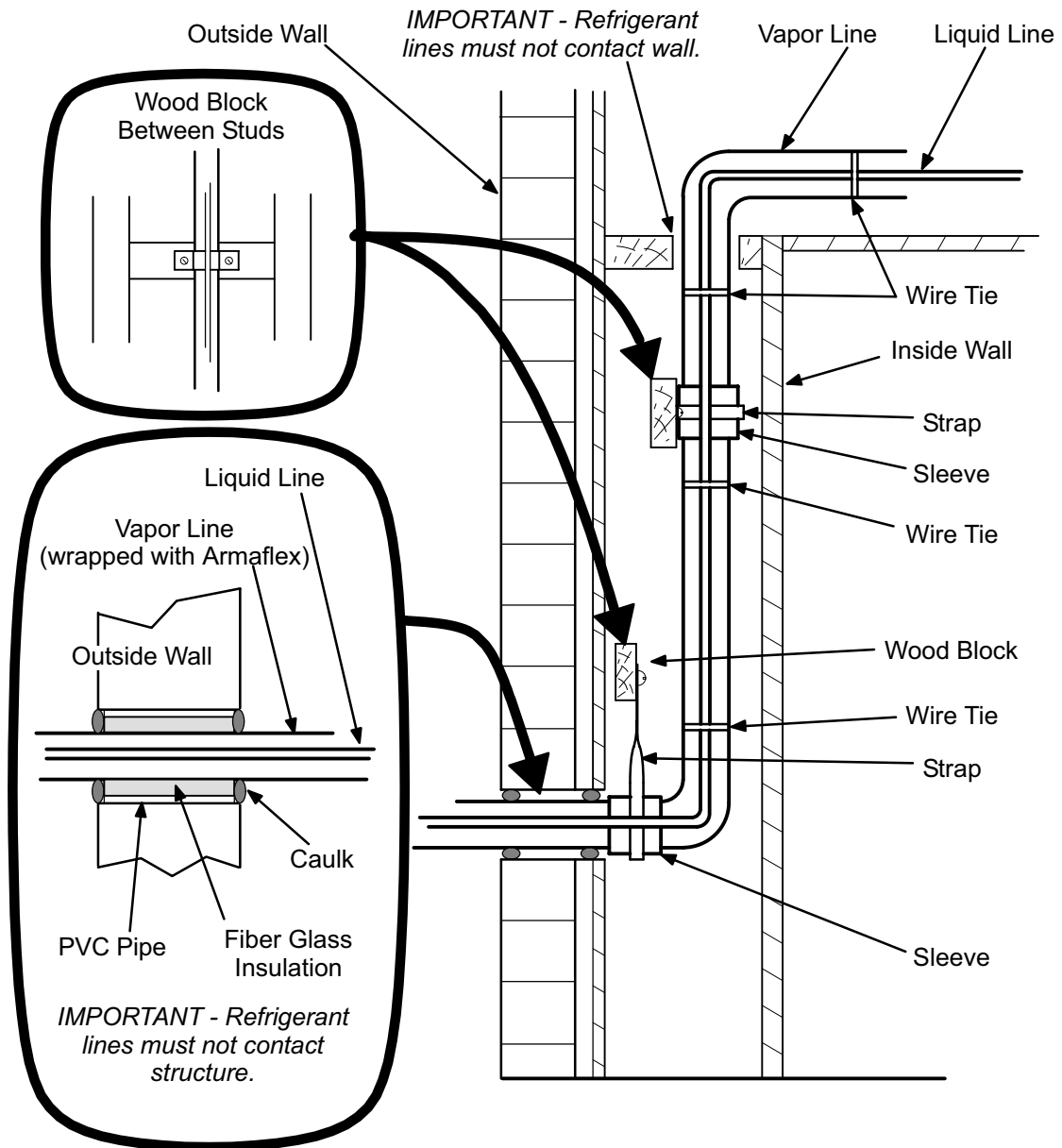

Figure 10

Refrigerant Line Sets: Installing Horizontal Runs

To hang line set from joist or rafter,
use either metal strapping material
or anchored heavy nylon wire ties.

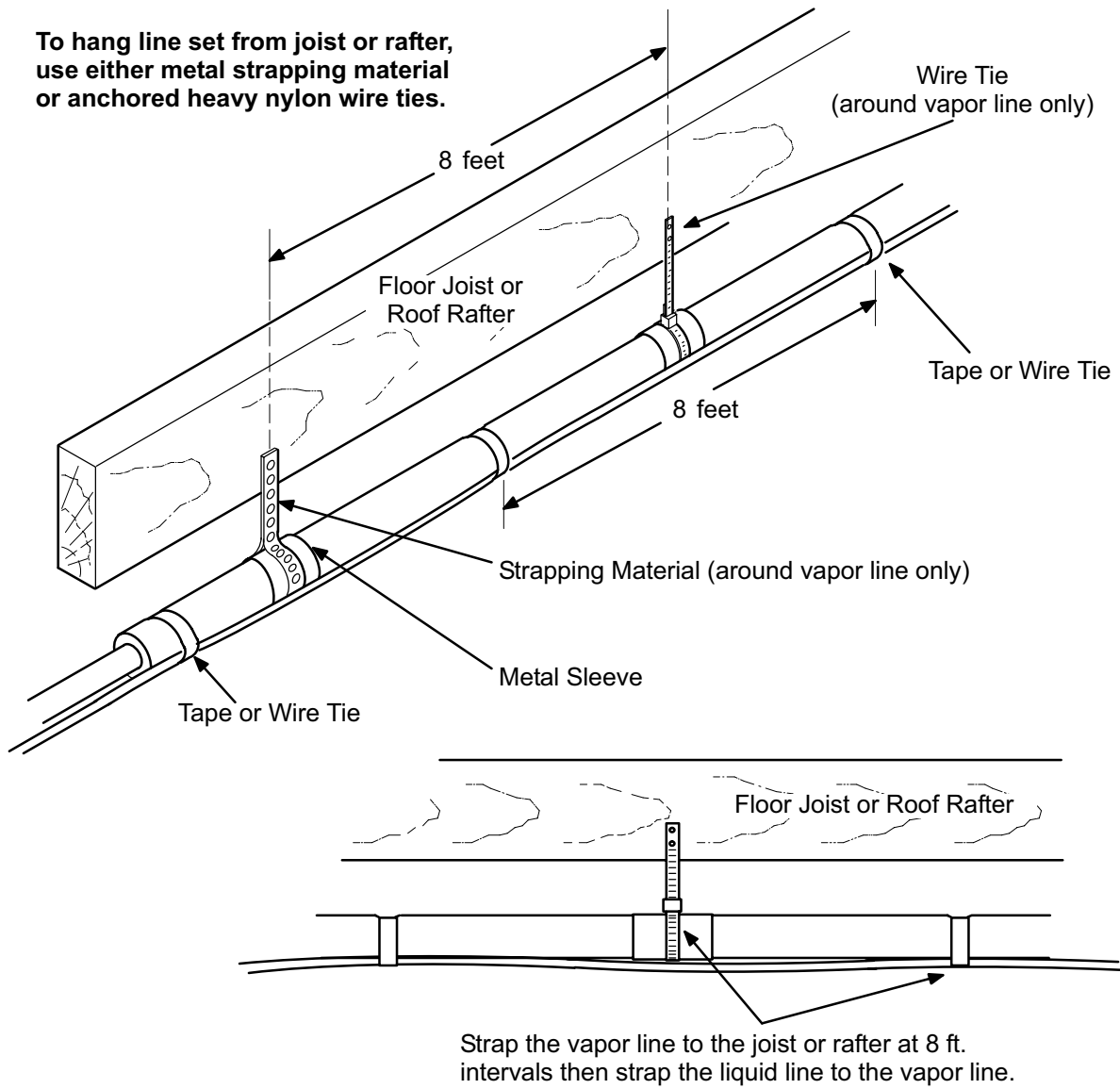

Figure 11

**Refrigerant Line Sets:
Transition From Vertical To Horizontal**

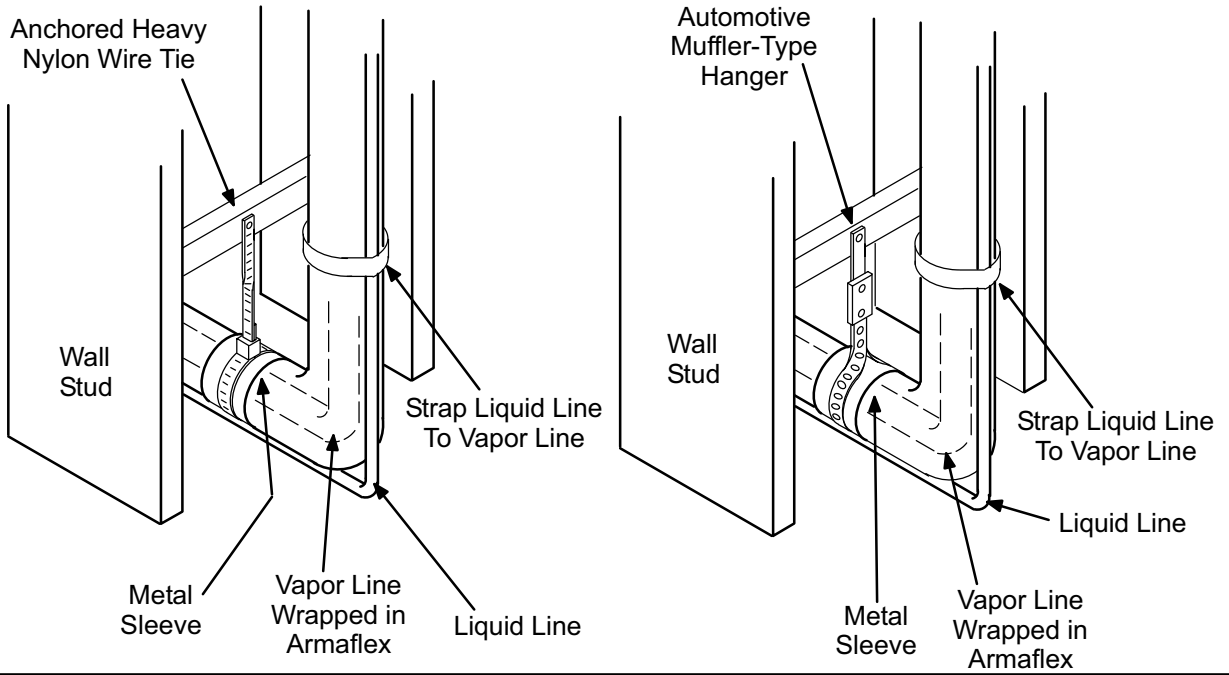

Figure 12

Outside Unit Placement and Installation

Install unit away from windows and away from neighbors' windows.

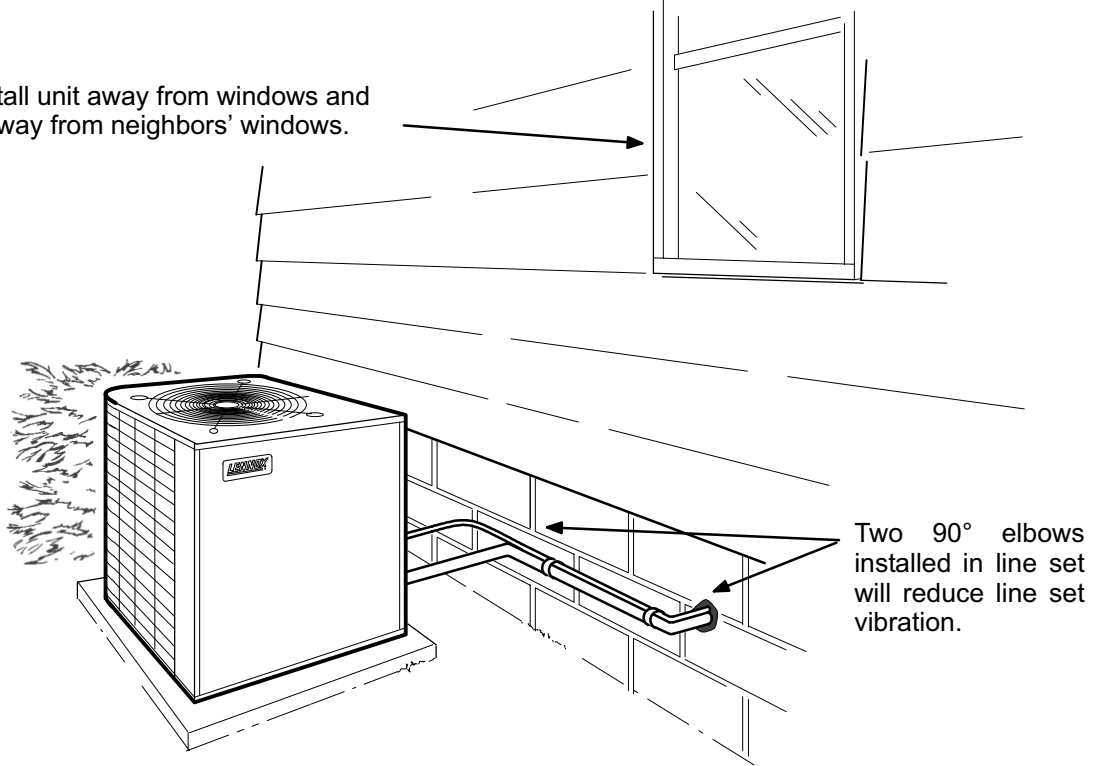

Figure 13

Isolation Grommets

Locate the provided isolation grommets. Use a knife to slit the webbing on each grommet. Slide larger grommet onto vapor line and smaller grommet onto liquid line. Insert grommets into mullion to isolate refrigerant lines from sheet metal edges.

⚠ WARNING

Polyol ester (POE) oils used with R410A refrigerant absorb moisture very quickly. It is very important that the refrigerant system be kept closed as much as possible. DO NOT remove line set caps or service valve stub caps until you are ready to make connections.

Brazing Connection Procedure

- 1 - The end of the refrigerant line must be cut square and its internal shape must remain round. The line must be free of nicks or dents and must be deburred (I.D. and O.D.)
- 2 - Before making line set connections, use dry nitrogen to purge the refrigerant piping. This will help to prevent oxidation and the introduction of moisture into the system.
- 3 - Use silver alloy brazing rods (5 or 6 percent *minimum* silver alloy for copper-to-copper brazing or 45 percent silver alloy for copper-to-brass or copper-to-steel brazing). Wrap a wet cloth around the valve body and the copper tube stub. Remove light maroon washers from service valves and shield light maroon stickers in order to protect them during brazing. Braze the line set to the service valve.
- 4 - Quench the joint with water or a wet cloth to prevent heat damage to the valve core and opening port.

IMPORTANT - The tube end must stay bottomed in the fitting during final assembly to ensure proper seating, sealing and rigidity.

Refrigerant Metering Device

HPXA19 units are used in check expansion valve systems only. See the Lennox Engineering Handbook for approved TXV match-ups and application information.

Check expansion valves equipped with Chatleff fittings are available from Lennox. Refer to the Engineering Handbook for applicable expansion valves for use with specific match-ups.

If you install a check expansion valve with an indoor coil that includes a fixed orifice, remove the orifice before installing the check expansion valve.

See figure 14 for installation of the indoor check expansion valve.

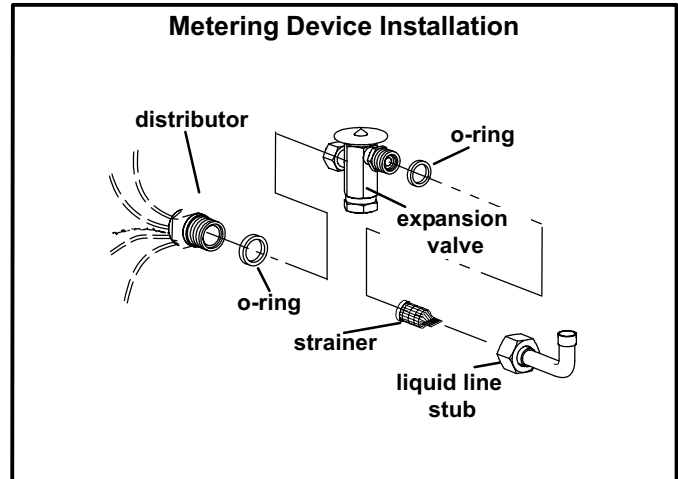

Figure 14

⚠ IMPORTANT

Failure to remove RFC orifice when installing an expansion valve on the indoor coil will result in improper operation and damage to the system.

Flushing Existing Line Set & Indoor Coil

⚠ WARNING



Danger of fire. Bleeding the refrigerant charge from only the high side may result in the low side shell and suction tubing being pressurized. Application of a brazing torch while pressurized may result in ignition of the refrigerant and oil mixture - check the high and low pressures before unbrazing.

NOTE - If the indoor unit line and set are new, skip this section and go on to the Manifold Gauge Set section.

⚠ IMPORTANT

If this unit is being matched with an approved line set or indoor coil that was previously charged with R22 refrigerant, or if it is being matched with a coil that was manufactured before January of 1999, the coil and line set must be flushed prior to installation. Take care to empty all existing traps. Polyol ester (POE) oils are used in Lennox units charged with R410A refrigerant. Residual mineral oil can act as an insulator, preventing proper heat transfer. It can also clog the thermal expansion valve, reducing system performance and capacity. Failure to properly flush the system per the instructions below will void the warranty.

⚠ IMPORTANT

The Environmental Protection Agency prohibits the intentional venting of HFC refrigerants during maintenance, service, repair and disposal of appliance. Approved methods of recovery, recycling or reclaiming must be followed.

⚠ CAUTION

This procedure should not be performed on systems which contain contaminants (Example: compressor burn out).

Required Equipment

You will need the following equipment in order to flush the existing line set and indoor coil: two clean R22 recovery bottles, an oilless recovery machine with a pump down feature, and two sets of gauges (one for use with R22 and one for use with the R410A).

Flushing Procedure

- 1 - Remove existing R22 refrigerant using the appropriate procedure below.

If the existing outdoor unit is not equipped with shut-off valves, or if the unit is not operational AND you plan to use the existing R22 refrigerant to flush the system -- Disconnect all power to the existing outdoor unit. Connect the existing unit, a clean recovery cylinder and the recovery machine according to the instructions provided with the recovery machine. Remove all R22 refrigerant from the existing system. Refer to gauges after shutdown to confirm

that the entire system is completely void of refrigerant. Disconnect the liquid and vapor lines from the existing outdoor unit.

If the existing outdoor unit is equipped with manual shut-off valves AND you plan to use NEW R22 refrigerant to flush the system -- Start the existing R22 system in the cooling mode and close the liquid line valve. Pump all of the existing R22 refrigerant back into the outdoor unit. (It may be necessary to bypass the low pressure switches to ensure complete refrigerant evacuation.) When the low side system pressures reach 0 psig, close the vapor line valve. Disconnect all power to the existing outdoor unit. Refer to gauges after shutdown to confirm that the valves are not allowing refrigerant to flow back into the low side of the system. Disconnect the liquid and vapor lines from the existing outdoor unit.

- 2 - Remove the existing outdoor unit. Set the new R410A unit and follow the brazing connection procedure which begins on the previous page to make line set connections. DO NOT install metering device at this time.

Make low voltage and line voltage connections to the new outdoor unit. **DO NOT turn on power to the unit or open the outdoor unit service valves at this time.**

⚠ IMPORTANT

The line set and indoor coil must be flushed with at least the same amount of clean refrigerant that previously charged the system. Check the charge in the flushing cylinder before proceeding.

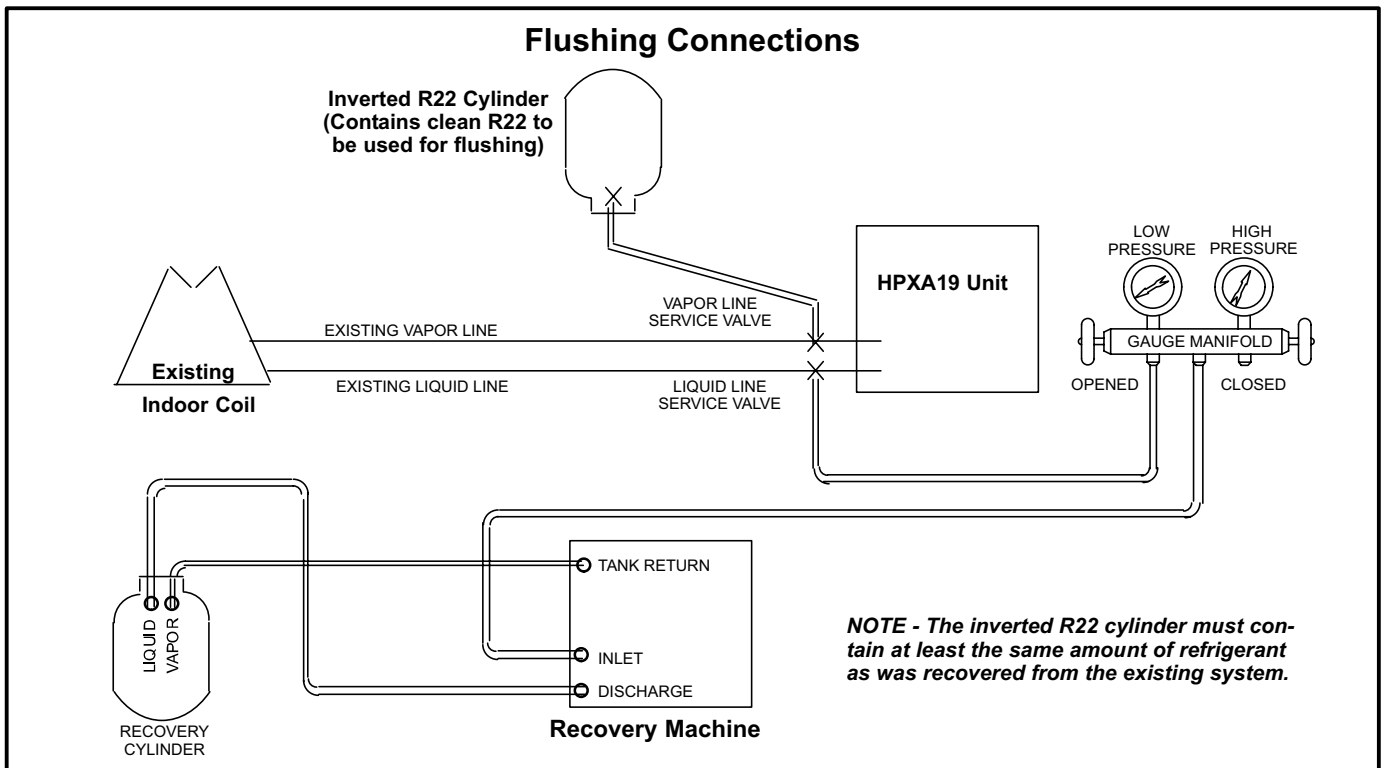

Figure 15

- 3 - Remove the existing refrigerant flow control orifice or thermal expansion/check valve before continuing with flushing procedures. The existing devices are not approved for use with R410A refrigerant and may prevent proper flushing. Use a field-provided fitting to reconnect the lines.
 - 4 - Remove the pressure tap valve cores from the HPXA19 unit's service valves. Connect an R22 cylinder with clean refrigerant to the vapor service valve. Connect the R22 gauge set to the liquid line valve and connect a recovery machine with an empty recovery tank to the gauge set.
 - 5 - Set the recovery machine for liquid recovery and start the recovery machine. Open the gauge set valves to allow the recovery machine to pull a vacuum on the existing system line set and indoor coil.
 - 6 - Invert the cylinder of clean R22 and open its valve to allow liquid refrigerant to flow into the system through the vapor line valve. Allow the refrigerant to pass from the cylinder and through the line set and the indoor coil before it enters the recovery machine.
 - 7 - After all of the liquid refrigerant has been recovered, switch the recovery machine to vapor recovery so that all of the R22 vapor is recovered.
- NOTE - A single system flush should remove all of the mineral oil from the existing refrigerant lines and indoor coil. A second flushing may be done (using clean refrigerant) if insufficient amounts of mineral oil were removed during the first flush. **Each time the system is flushed, you must allow the recovery machine to pull a vacuum on the system at the end of the procedure.***
- 8 - Close the valve on the inverted R22 drum and the gauge set valves. Pump the remaining refrigerant out of the recovery machine and turn the machine off.
 - 9 - Use nitrogen to break the vacuum on the refrigerant lines and indoor coil before removing the recovery machine, gauges and R22 refrigerant drum. Reinstall pressure tap valve cores into HPXA19 service valves.
 - 10 - Install the provided check/expansion valve (approved for use with R410A refrigerant) in the liquid line at the indoor coil.

Manifold Gauge Set

⚠ IMPORTANT

Manifold gauge sets used with systems charged with R410A refrigerant must be capable of handling the higher system operating pressures. The gauges should be rated for use with pressures of 0 - 800 on the high side and a low side of 30" vacuum to 250 psi with dampened speed to 500 psi. Gauge hoses must be rated for use at up to 800 psi of pressure with a 4000 psi burst rating.

Service Valves

The liquid line and vapor line service valves (figures 16 and 17) and gauge ports are used for leak testing, evacuating, charging, and checking charge. See table 1 for torque requirements.

Each valve is equipped with a service port which has a factory-installed Schrader valve. A service port cap protects the Schrader valve from contamination and serves as the primary leak seal.

**Table 1
Torque Requirements**

Part	Recommended Torque	
Service valve cap	8 ft.- lb.	11 NM
Sheet metal screws	16 in.- lb.	2 NM
Machine screws #10	28 in.- lb.	3 NM
Compressor bolts	90 in.- lb.	10 NM
Gauge port seal cap	8 ft.- lb.	11 NM

⚠ IMPORTANT

Service valves are closed to the outdoor unit and open to line set connections. Do not open the valves until refrigerant lines have been leak tested and evacuated. All precautions should be exercised to keep the system free from dirt, moisture and air.

To Access Schrader Port:

- 1 - Remove service port cap with an adjustable wrench.
- 2 - Connect gauge to the service port.
- 3 - When testing is complete, replace service port cap. Tighten finger tight, then an additional 1/6 turn.

To Open Service Valve:

- 1 - Remove stem cap with an adjustable wrench.
- 2 - Using service wrench and hex head extension, back the stem out counterclockwise as far as it will go.
NOTE - Use a 3/16" hex head extension for liquid line sizes.
- 3 - Replace stem cap and tighten it firmly. Tighten finger tight, then tighten an additional 1/6 turn.

To Close Service Valve:

- 1 - Remove stem cap with an adjustable wrench.
- 2 - Using service wrench and hex head extension, turn stem clockwise to seat valve. Tighten it firmly.
NOTE - Use a 3/16" hex head extension for liquid line sizes.
- 3 - Replace stem cap. Tighten finger tight, then tighten an additional 1/6 turn.

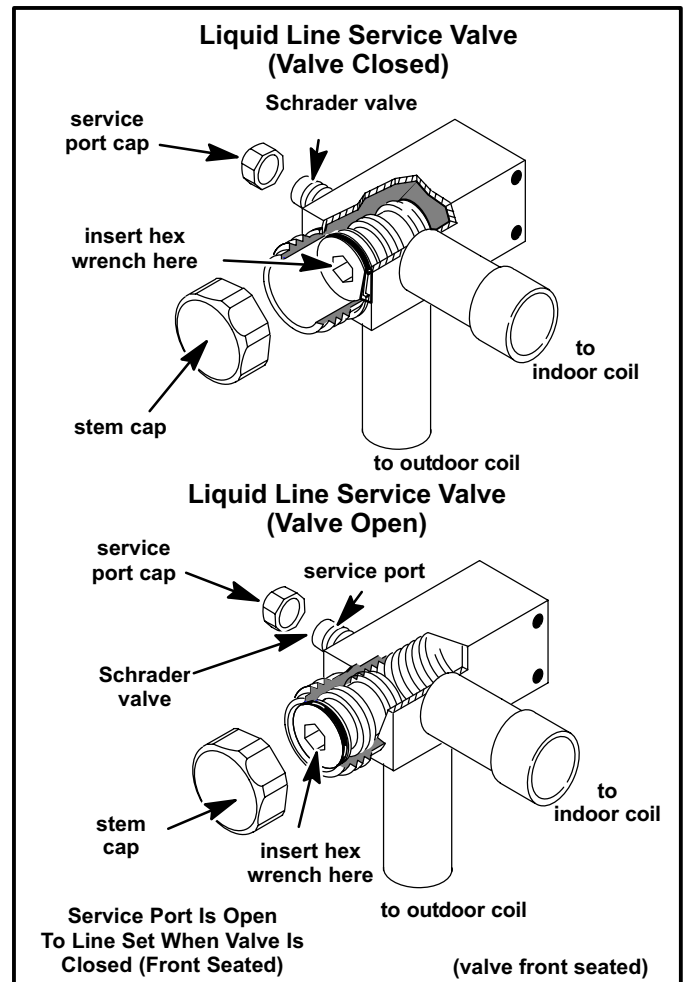

Figure 16

Vapor Line (Ball Type) Valve

Vapor line service valves function the same way as the other valves, the difference is in the construction. These valves are not rebuildable. If a valve has failed, you must replace it. A ball valve valve is illustrated in figure 17.

The ball valve is equipped with a service port with a factory-installed Schrader valve. A service port cap protects the Schrader valve from contamination and assures a leak-free seal.

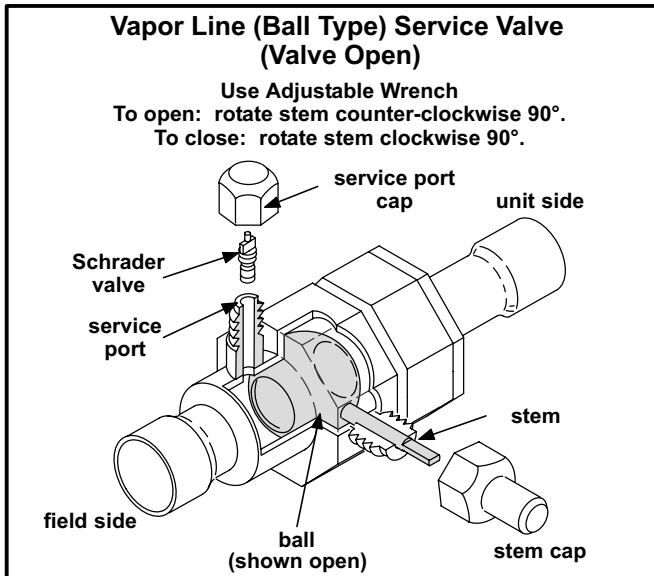

Figure 17

Leak Testing

After the line set has been connected to the indoor and outdoor units, the line set connections and indoor unit must be checked for leaks.

⚠ WARNING

Refrigerant can be harmful if it is inhaled. Refrigerant must be used and recovered responsibly.

Failure to follow this warning may result in personal injury or death.

⚠ WARNING



Danger of explosion: Can cause equipment damage, injury or death. Never use oxygen to pressurize a refrigeration or air conditioning system. Oxygen will explode on contact with oil and could cause personal injury.

⚠ WARNING

Danger of explosion: Can cause equipment damage, injury or death. When using a high pressure gas such as dry nitrogen to pressurize a refrigeration or air conditioning system, use a regulator that can control the pressure down to 1 or 2 psig (6.9 to 13.8 kPa).

Using an Electronic Leak Detector

- 1 - Connect a cylinder of R410A to the center port of the manifold gauge set.
- 2 - With both manifold valves closed, open the valve on the R410A cylinder (vapor only).

- 3 - Open the high pressure side of the manifold to allow the R410A into the line set and indoor unit. Weigh in a trace amount of R410A. [A trace amount is a maximum of 2 ounces (57 g) or 3 pounds (31 kPa) pressure.] Close the valve on the R410A cylinder and the valve on the high pressure side of the manifold gauge set. Disconnect the R410A cylinder.
- 4 - Connect a cylinder of nitrogen with a pressure regulating valve to the center port of the manifold gauge set.
- 5 - Connect the manifold gauge set high pressure hose to the vapor valve service port. (Normally, the high pressure hose is connected to the liquid line port; however, connecting it to the vapor port better protects the manifold gauge set from high pressure damage.)
- 6 - Adjust the nitrogen pressure to 150 psig (1034 kPa). Open the valve on the high side of the manifold gauge set which will pressurize line set and indoor unit.
- 7 - After a few minutes, open a refrigerant port to ensure the refrigerant you added is adequate to be detected. (Amounts of refrigerant will vary with line lengths.) Check all joints for leaks. Purge nitrogen and R410A mixture. Correct any leaks and recheck.

⚠ IMPORTANT

Leak detector must be capable of sensing HFC refrigerant.

Evacuation

Evacuating the system of noncondensables is critical for proper operation of the unit. Noncondensables are defined as any gas that will not condense under temperatures and pressures present during operation of an air conditioning system. Noncondensables and water vapor combine with refrigerant to produce substances that corrode copper piping and compressor parts.

⚠ IMPORTANT

Use a thermocouple or thermistor electronic vacuum gauge that is calibrated in microns. Use an instrument that reads from 50 microns to at least 23,000 microns.

- 1 - Connect the manifold gauge set to the service valve ports as follows:
 - low pressure gauge to *vapor* line service valve
 - high pressure gauge to *liquid* line service valve
- 2 - Connect micron gauge.
- 3 - Connect the vacuum pump (with vacuum gauge) to the center port of the manifold gauge set.
- 4 - Open both manifold valves and start vacuum pump.
- 5 - Evacuate the line set and indoor unit to an **absolute pressure** of 23,000 microns (29.01 inches of mercury). During the early stages of evacuation, it is desirable to close the manifold gauge valve at least once to determine if there is a rapid rise in **absolute pressure**. A rapid rise in pressure indicates a relatively large leak. If this occurs, repeat the leak testing procedure.

NOTE - The term absolute pressure means the total actual pressure within a given volume or system, above the absolute zero of pressure. Absolute pressure in a vacuum is equal to atmospheric pressure minus vacuum pressure.

- 6 - When the absolute pressure reaches 23,000 microns (29.01 inches of mercury), close the manifold gauge valves, turn off the vacuum pump and disconnect the manifold gauge center port hose from vacuum pump. Attach the manifold center port hose to a nitrogen cylinder with pressure regulator set to 150 psig (1034 kPa) and purge the hose. Open the manifold gauge valves to break the vacuum in the line set and indoor unit. Close the manifold gauge valves.

⚠ WARNING

Danger of Equipment Damage. Avoid deep vacuum operation. Do not use compressors to evacuate a system. Extremely low vacuums can cause internal arcing and compressor failure. Damage caused by deep vacuum operation will void warranty.

- 7 - Shut off the nitrogen cylinder and remove the manifold gauge hose from the cylinder. Open the manifold gauge valves to release the nitrogen from the line set and indoor unit.
- 8 - Reconnect the manifold gauge to the vacuum pump, turn the pump on, and continue to evacuate the line set and indoor unit until the absolute pressure does not rise above 500 microns (29.9 inches of mercury) within a 20-minute period after shutting off the vacuum pump and closing the manifold gauge valves.
- 9 - When the absolute pressure requirement above has been met, disconnect the manifold hose from the vacuum pump and connect it to an upright cylinder of R410A refrigerant. Open the manifold gauge valves to break the vacuum from 1 to 2 psig positive pressure in the line set and indoor unit. Close manifold gauge valves and shut off the R410A cylinder and remove the manifold gauge set.

Start-Up

⚠ IMPORTANT

If unit is equipped with crankcase heater, it should be energized 24 hours before unit start-up to prevent compressor damage as a result of slugging.

- 1 - Rotate fan to check for frozen bearings or binding.

- 2 - Inspect all factory- and field-installed wiring for loose connections.
- 3 - After evacuation is complete, open the liquid line and vapor line service valves (counterclockwise) to release refrigerant charge (contained in outdoor unit) into the system.
- 4 - Replace stem caps and secure finger tight, then tighten an additional (1/6) one-sixth of a turn.
- 5 - Check voltage supply at the disconnect switch. The voltage must be within the range listed on the unit nameplate. If not, do not start the equipment until the power company has been consulted and the voltage condition has been corrected.
- 6 - Set the thermostat for a cooling demand, turn on power to indoor blower unit and close the outdoor unit disconnect to start the unit.
- 7 - Recheck voltage while the unit is running. Power must be within range shown on the nameplate.

Charging

This system is charged with R410A refrigerant which operates at much higher pressures than R22. The field-provided check/expansion valve for the indoor unit must be approved for use with R410A. This unit is NOT approved for use with coils which include metering orifices or capillary tubes.

Processing Procedure

The unit is factory-charged with the amount of R410A refrigerant indicated on the unit rating plate. This charge is based on a matching indoor coil and outdoor coil with a 15 foot (4.6 m) line set. For varying lengths of line set, refer to table 2 for refrigerant charge adjustment.

Table 2

Liquid Line Set Diameter	Oz. per 5 ft. (grams per 1.5 m) adjust from 15 ft. (4.6 m) line set*
3/8 in. (10 mm)	3 ounces per 5 feet (85g per 1.5 m)

**If line length is greater than 15 ft. (4.6 m), add this amount. If line length is less than 15 ft. (4.6 m), subtract this amount.*

⚠ IMPORTANT

Mineral oils are not compatible with R410A. If oil must be added, it must be a polyol ester oil.

The compressor is charged with sufficient polyol ester oil for line set lengths up to 50 ft.

The outdoor unit should be charged during warm weather. However, applications arise in which charging must occur in the colder months. *The method of charging is determined by the outdoor ambient temperature.*

Measure the liquid line temperature and the outdoor ambient temperature as outlined below:

- 1 - Connect manifold gauge set to service valves as shown in figure 18:

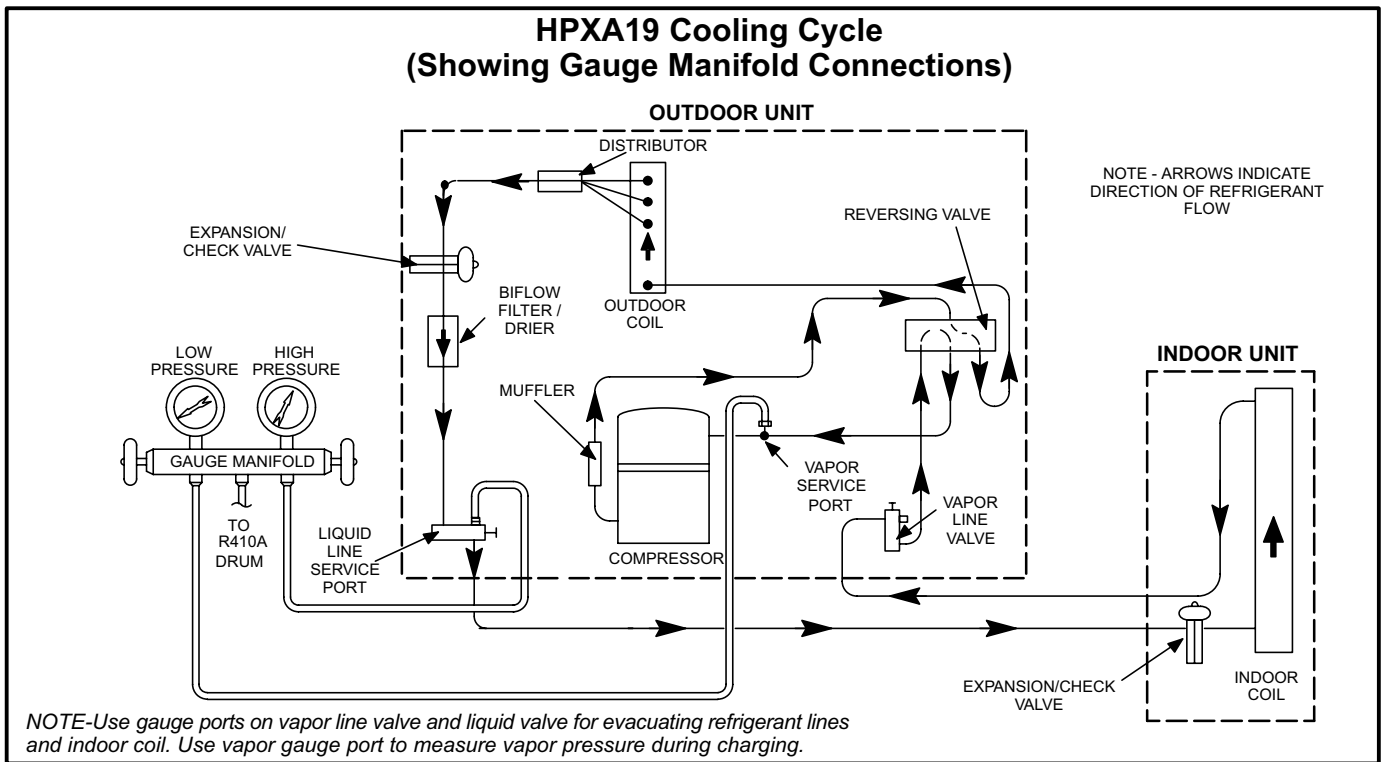

Figure 18

- low pressure gauge to *vapor* valve service port
- high pressure gauge to *liquid* valve service port

Connect the center manifold hose to an upright cylinder of R410A . Close manifold gauge set valves.

- 2 - Set the room thermostat to call for heat. This will create the necessary load for properly charging the system in the cooling cycle.
- 3 - Use a digital thermometer to record the outdoor ambient temperature.
- 4 - When the heating demand has been satisfied, switch the thermostat to cooling mode with a set point of 68°F (20°C). When pressures have stabilized, use a digital thermometer to record the liquid line temperature.
- 5 - The outdoor temperature will determine which charging method to use. Proceed with the appropriate charging procedure.

Weighing in the Charge TXV Systems – Outdoor Temp. < 65°F (18°C)

If the system is void of refrigerant, or if the outdoor ambient temperature is cool, the refrigerant charge should be weighed into the unit. Do this after any leaks have been repaired.

- 1 - Recover the refrigerant from the unit.
- 2 - Conduct a leak check, then evacuate as previously outlined.
- 3 - Weigh in the unit nameplate charge.

If weighing facilities are not available or if you are charging the unit during warm weather, follow one of the other procedures outlined below.

Subcooling Method Outdoor Temp. < 65°F (18°C)

When the outdoor ambient temperature is below 65°F (18°C), use the subcooling method to charge the unit. It may be necessary to restrict the air flow through the outdoor coil to achieve pressures in the 325-375 psig (2240-2585 kPa) range. These higher pressures are necessary for checking the charge. Block equal sections of air intake panels and move obstructions sideways until the liquid pressure is in the 325-375 psig (2240-2585 kPa) range. See figure 19.

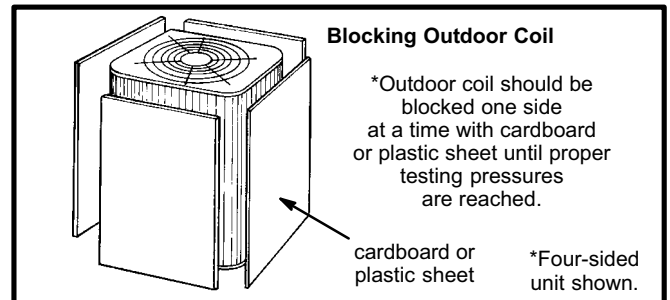

Figure 19

- 1 - With the manifold gauge hose still on the liquid service port and the unit operating stably, use a digital thermometer to record the liquid line temperature.
- 2 - At the same time, record the liquid line pressure reading.

- 3 - Use a temperature/pressure chart for R410A to determine the saturation temperature for the liquid line pressure reading. See table 7.
- 4 - Subtract the liquid line temperature from the saturation temperature (according to the chart) to determine subcooling. **(Saturation temperature - Liquid line temperature = Subcooling)**
- 5 - Compare the subcooling value with those in table 3. If subcooling is greater than shown, recover some refrigerant. If subcooling is less than shown, add some refrigerant. Be aware of the R410A refrigerant cylinder. It will be light maroon-colored. Refrigerant should be added through the vapor line valve in the liquid state. **Some R410A cylinders are equipped with a dip tube that allows you to draw liquid refrigerant from the bottom of the cylinder without turning the cylinder upside-down. The cylinder will be marked if it is equipped with a dip tube.**

**Table 3
Subcooling Values for Charging**

Model Number	Second Stage (High Capacity) Subcooling Values Conversion Temp. - Liquid Line Temp. °F (°C)
HPXA19-024	11.0 ± 1 (6 ± .5)
HPXA19-036	8.5 ± 1 (4.7 ± .5)
HPXA19-038	10.5 ± 1 (5.8 ± .5)
HPXA19-048	7.5 ± 1 (4.1 ± .5)
HPXA19-060	7.0 ± 1 (3.9 ± .5)

**Charging Using Normal Operating Pressures
and the Approach Method
Outdoor Temp. ≥ 65°F (18°C)**

The following procedure is intended as a general guide and is for use on expansion valve systems only.

For best results, indoor temperature should be 70°F (21°C) to 80°F (26°C). Monitor system pressures while charging.

- 1 - Record outdoor ambient temperature using a digital thermometer.
- 2 - Attach high pressure gauge set and operate unit for several minutes to allow system pressures to stabilize.

- 3 - Compare stabilized pressures with those provided in tables 5 and 6, "Normal Operating Pressures." Minor variations in these pressures may be expected due to differences in installations. Significant differences could mean that the system is not properly charged or that a problem exists with some component in the system. Pressures higher than those listed indicate that the system is overcharged. Pressures lower than those listed indicate that the system is undercharged. Verify adjusted charge using the approach method.

Approach Method

- 4 - Use the same digital thermometer used to check outdoor ambient temperature to check liquid line temperature. Verify the unit charge using the approach method.
- 5 - The difference between the ambient and liquid temperatures should match values given in table 4. If the values don't agree with the those in table 4, add refrigerant to lower the approach temperature or recover refrigerant from the system to increase the approach temperature.

**Table 4
Approach Values for Charging**

Model Number	Second Stage (High Capacity) Approach Temperature Liquid Line Temp. - Outdoor Ambient °F (°C)
HPXA19-024	4.0 ± 1 (2.2 ± .5)
HPXA19-036	7.0 ± 1 (3.9 ± .5)
HPXA19-038	4.0 ± 1 (2.2 ± .5)
HPXA19-048	8.0 ± 1 (4.4 ± .5)
HPXA19-060	10.0 ± 1 (5.6 ± .5)

! IMPORTANT

Use table 5 as a general guide when performing maintenance checks. This is not a procedure for charging the unit (Refer to Charging/Checking Charge section). Minor variations in these pressures may be expected due to differences in installations. Significant differences could mean that the system is not properly charged or that a problem exists with some component in the system.

Table 5
Normal Operating Pressures: Cooling Operation
(Liquid ±10 and Vapor ±5 psig)

First Stage (Low Capacity)										
Outdoor Coil Entering Air Temp. °F (°C)	HPXA19-024		HPXA19-036		HPXA19-038		HPXA19-048		HPXA19-060	
	Liquid	Vapor	Liquid	Vapor	Liquid	Vapor	Liquid	Vapor	Liquid	Vapor
65 (18.3)	217	143	227	142	222	142	222	140	225	140
75 (23.9)	250	145	262	145	255	145	258	143	259	142
85 (29.4)	291	147	305	146	295	146	298	145	293	146
95 (35.0)	336	149	352	148	343	148	343	147	356	147
105 (40.6)	386	151	403	152	390	153	402	147	408	147
115 (49.0)	440	153	458	155	446	156	452	152	455	151
Second Stage (High Capacity)										
Outdoor Coil Entering Air Temp. °F (°C)	HPXA19-024		HPXA19-036		HPXA19-038		HPXA19-048		HPXA19-060	
	Liquid	Vapor	Liquid	Vapor	Liquid	Vapor	Liquid	Vapor	Liquid	Vapor
65 (18.3)	222	143	244	136	231	133	232	134	249	126
75 (23.9)	256	145	282	139	263	139	266	136	289	134
85 (29.4)	302	145	325	142	305	142	309	139	330	140
95 (35.0)	349	147	377	144	354	145	359	142	378	143
105 (40.6)	403	149	428	146	403	147	410	144	433	146
115 (49.0)	464	152	488	148	461	149	468	147	492	149

Table 6
Normal Operating Pressures: Heating Operation
(Liquid ±10 and Vapor ±5 psig)

First Stage (Low Capacity)										
Outdoor Coil Entering Air Temp. °F (°C)	HPXA19-024		HPXA19-036		HPXA19-038		HPXA19-048		HPXA19-060	
	Liquid	Vapor	Liquid	Vapor	Liquid	Vapor	Liquid	Vapor	Liquid	Vapor
40 (4.4)	321	99	296	95	308	97	315	97	319	93
50 (10)	340	120	310	112	323	116	330	114	335	111
Second Stage (High Capacity)										
Outdoor Coil Entering Air Temp. °F (°C)	HPXA19-024		HPXA19-036		HPXA19-038		HPXA19-048		HPXA19-060	
	Liquid	Vapor	Liquid	Vapor	Liquid	Vapor	Liquid	Vapor	Liquid	Vapor
20 (-7.0)	273	68	277	60	288	59	294	60	300	57
30 (-1.0)	296	80	296	74	308	74	303	75	312	70
40 (4.4)	321	95	321	88	316	90	314	90	323	83
50 (10)	341	115	341	104	330	108	325	106	339	97

**Table 7
R410A Temperature/Pressure Chart**

Temperature °F	Pressure Psig	Temperature °F	Pressure Psig	Temperature °F	Pressure Psig	Temperature °F	Pressure Psig
32	100.8	63	178.5	94	290.8	125	445.9
33	102.9	64	181.6	95	295.1	126	451.8
34	105.0	65	184.3	96	299.4	127	457.6
35	107.1	66	187.7	97	303.8	128	463.5
36	109.2	67	190.9	98	308.2	129	469.5
37	111.4	68	194.1	99	312.7	130	475.6
38	113.6	69	197.3	100	317.2	131	481.6
39	115.8	70	200.6	101	321.8	132	487.8
40	118.0	71	203.9	102	326.4	133	494.0
41	120.3	72	207.2	103	331.0	134	500.2
42	122.6	73	210.6	104	335.7	135	506.5
43	125.0	74	214.0	105	340.5	136	512.9
44	127.3	75	217.4	106	345.3	137	519.3
45	129.7	76	220.9	107	350.1	138	525.8
46	132.2	77	224.4	108	355.0	139	532.4
47	134.6	78	228.0	109	360.0	140	539.0
48	137.1	79	231.6	110	365.0	141	545.6
49	139.6	80	235.3	111	370.0	142	552.3
50	142.2	81	239.0	112	375.1	143	559.1
51	144.8	82	242.7	113	380.2	144	565.9
52	147.4	83	246.5	114	385.4	145	572.8
53	150.1	84	250.3	115	390.7	146	579.8
54	152.8	85	254.1	116	396.0	147	586.8
55	155.5	86	258.0	117	401.3	148	593.8
56	158.2	87	262.0	118	406.7	149	601.0
57	161.0	88	266.0	119	412.2	150	608.1
58	163.9	89	270.0	120	417.7	151	615.4
59	166.7	90	274.1	121	423.2	152	622.7
60	169.6	91	278.2	122	428.8	153	630.1
61	172.6	92	282.3	123	434.5	154	637.5
62	195.5	93	286.5	124	440.2	155	645.0

System Operation

The outdoor unit and indoor blower cycle on demand from the room thermostat. When the thermostat blower switch is in the **ON** position, the indoor blower operates continuously.

Thermostat Operation

Some indoor thermostats incorporate isolating contacts and an emergency heat function (which includes an amber indicating light). The thermostat is not included with the unit and must be purchased separately.

Emergency Heat (Amber Light)

An emergency heat function is designed into some room thermostats. This feature is applicable when isolation of the outdoor unit is required, or when auxiliary electric heat is staged by outdoor thermostats. When the room thermostat is placed in the emergency heat position, the outdoor unit control circuit is isolated from power and field-provided relays bypass the outdoor thermostats. An amber indicating light simultaneously comes on to remind the homeowner that he is operating in the emergency heat mode.

Emergency heat is usually used during an outdoor unit shutdown, but it should also be used following a power outage if power has been off for over an hour and the outdoor temperature is below 50°F (10°C). System should be left in the emergency heat mode at least six hours to allow the crankcase heater sufficient time to prevent compressor slugging.

System Operation Monitor

The system operation monitor detects the most common fault conditions in the heat pump system. When an abnormal condition is detected, the module communicates the specific condition through its ALERT and TRIP lights. The monitor is capable of detecting both mechanical and electrical system problems. See figure 20 for the system operation monitor

! IMPORTANT

This monitor does not provide safety protection. The monitor is a monitoring device only and cannot control or shut down other devices

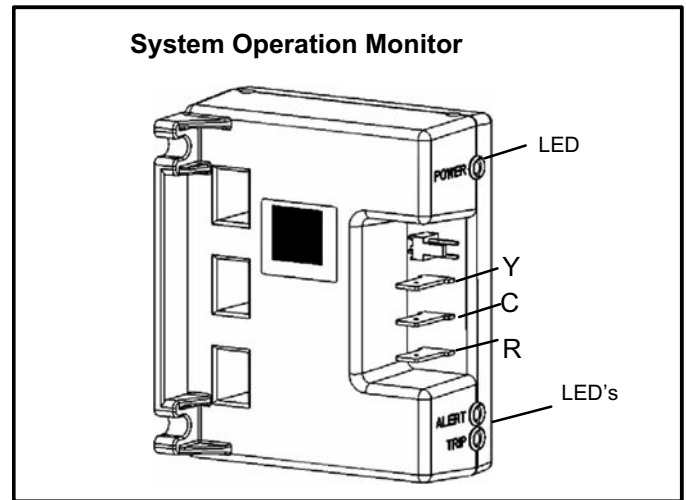

Figure 20

LED Functions

See table 8 for LED troubleshooting diagnostic codes.

Power LED (green) - indicates voltage within the range of 19-28VAC is present at the power connection of the monitor.

Alert LED (yellow) - communicates an abnormal system condition through a unique flash code. The alert LED will flash a number of times consecutively, pause and then repeat the process. The number of consecutive flashes, defined as the Flash Code, correlates to a particular abnormal condition.

Trip LED (red) - indicates there is a demand signal from the thermostat but no current to the compressor is detected by the monitor.

Flash code number corresponds to a number of LED flashes, followed by a pause, and then repeated.

TRIP and ALERT LEDs flashing at the same time indicates that the control circuit voltage is too low for operation.

Reset ALERT flash code by removing 24VAC power from monitor. Last ALERT flash code will display for 1 minute after monitor is powered on.

Filter Drier

The unit is equipped with a large-capacity biflow filter drier which keeps the system clean and dry. If replacement is necessary, order another of like design and capacity. The replacement filter drier must be suitable for use with R410A refrigerant.

**Table 8
System Operation Monitor Codes**

Status LED	Status LED Description	Status LED Troubleshooting Information
Green "Power"	Module has power.	Supply voltage is present at module terminals.
Red "Trip"	Thermostat demand signal Y1 is present, but the compressor is not running. <i>NOTE - during 5 minute delay in defrost board the red "trip" light will be on.</i>	<ol style="list-style-type: none"> Compressor protector is open. Outdoor unit power disconnect is open. Compressor circuit breaker or fuse(s) is open. Broken wire or connector is not making contact. Low pressure switch open if present in the system. Compressor contactor has failed to close.
Yellow "Alert" Flash Code 1 (Does not apply to heat pump or to two-stage split systems)	Long Run Time Compressor is running extremely long run cycles	<ol style="list-style-type: none"> Low refrigerant charge. Evaporator blower is not running. Evaporator coil is frozen. Faulty metering device. Condenser coil is dirty Liquid line restriction (filter drier blocked if present) Thermostat is malfunctioning.
Yellow "Alert" Flash Code 2	System Pressure Trip Discharge or suction pressure out of limits or compressor overloaded	<ol style="list-style-type: none"> High head pressure. Condenser coil poor air circulation (dirty, blocked, damaged). Condenser fan is not running. Return air duct has substantial leakage. If low pressure switch is present, check Flash Code 1 information.
Yellow "Alert" Flash Code 3	Short Cycling Compressor is running only briefly	<ol style="list-style-type: none"> Thermostat demand signal is intermittent. Time delay relay or control board is defective. If high pressure switch is present, check Flash Code 2 information. If low pressure switch is present, check Flash Code 1 information.
Yellow "Alert" Flash Code 4	Locked Rotor	<ol style="list-style-type: none"> Run capacitor has failed. Low line voltage (contact utility if voltage at disconnect is low). Excessive liquid refrigerant in the compressor. Compressor bearings are seized.
Yellow "Alert" Flash Code 5	Open Circuit	<ol style="list-style-type: none"> Outdoor unit power disconnect is open. Unit circuit breaker or fuse(s) is open. Unit contactor has failed to close. High pressure switch is open and requires manual reset. Open circuit in compressor supply wiring or connections. Unusually long compressor protector reset time due to extreme ambient temperature. Compressor windings are damaged.
Yellow "Alert" Flash Code 6	Open Start Circuit Current only in run circuit	<ol style="list-style-type: none"> Run capacitor has failed. Open circuit in compressor start wiring or connections. Compressor start winding is damaged.
Yellow "Alert" Flash Code 7	Open Run Circuit Current only in start circuit	<ol style="list-style-type: none"> Open circuit in compressor start wiring or connections. Compressor start winding is damaged.
Yellow "Alert" Flash Code 8	Welded Contactor Compressor always runs	<ol style="list-style-type: none"> Compressor contactor failed to open. Thermostat demand signal not connected to module.
Yellow "Alert" Flash Code 9	Low Voltage Control circuit < 17VAC	<ol style="list-style-type: none"> Control circuit transformer is overloaded Low line voltage (contact utility if voltage at disconnect is low.)
<ul style="list-style-type: none"> Flash code number corresponds to a number of LED flashes, followed by a pause, and then repeated. TRIP and ALERT LEDs flashing at the same time indicates that the control circuit voltage is too low for operation. Reset ALERT flash code by removing 24VAC power from monitor. Last ALERT flash code will display for 1 minute after monitor is powered on. 		

Variable Speed Condenser Fan (-038 only)

THE condenser fan motor is a variable speed motor with RPM settings of 700 (Y1 -1st stage) and 820 (Y2 - 2nd stage).

Low Ambient Thermostat (second stage) S23

The low ambient thermostat S23 (figure 21) is a SPST thermostat and is located in the unit control box. The cap-tube sensor is coiled adjacent to the control.

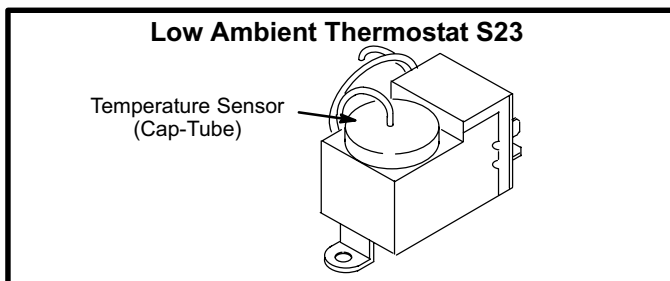

Figure 21

The S23 continually monitors the temperature inside the control box. When the control box temperature drops below the control setpoint, the control closes. When the control closes, the contacts shunt across Y1 and Y2 inside the unit. When heating demand is present and the S23 is closed, the compressor will run in two-stage mode.

The S23 has field adjustable setpoints. Temperature differential (difference between cut-in and cut-out) is fixed and cannot be adjusted. Table 9 shows S23 thermostat setpoints. The thermostat is factory set to close at 40±2°F on a temperature drop and reset at 50±2°F on a temperature rise.

Table 9
Low Ambient Thermostat Setpoints

Low Ambient Thermostat Adjustable Range	Factory Setting	Min.	Max.
Cut-In (Close on Temperature Drop)	40±2°F	37±2°F	55±2°F
Cut-Out (Open on Temperature Rise)	50±2°F	47±2°F	65±2°F

Regional climatic conditions may require the control to be adjusted to a different setting. The adjustment screw is located on the bottom of the control box. A hole cut into the bottom shelf of the control box provides access to the second stage control adjustment screw from the compressor compartment. See figure 22.

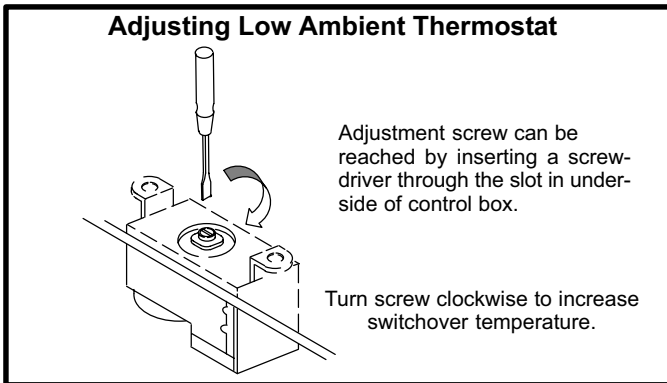

Figure 22

Figure 23 shows the adjustment range of the control. Turn adjustment screw clockwise to raise the switchover temperature and counterclockwise to lower the switchover temperature.

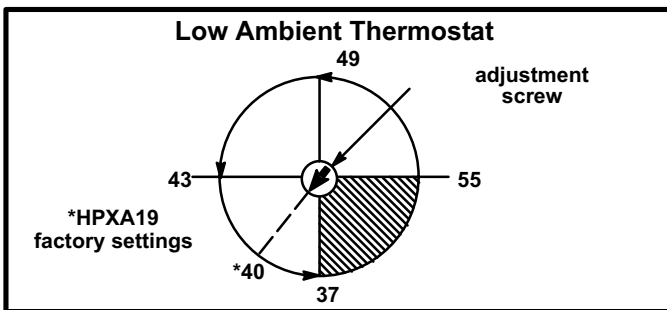

Figure 23

NOTE: Because this control is in the compressor compartment, the ambient temperature sensed may be 10 °F to 15°F higher than the outdoor ambient. Things that can affect this temperature variation are long compressor run times, conditions where the crankcase heater is energized continuously, or if it is in direct sunlight.

If this condition exists it can prevent the S23 from closing and restrict the unit to low capacity heating when there is a requirement for high capacity heat.

Ambient Compensation Adjustments

In order to overcome this potential situation, there are two possible adjustments:

- The factory setting of the S23 can be reset to a higher temperature. This will allow the controller to compensate for the ambient temperature differences. (Control setting 65°F, compartment 65°F - outdoor ambient 55°F).
- Secondly, the capillary tube on the control can be routed with the low voltage thermostat wires. Because the capillary tube senses at its coldest point, temperature variation will be reduced between the control and the outdoor ambient temperature. (Keep capillary tube away from direct sunlight).

Defrost System

Discharge Temperature Thermostat

Units are equipped with a discharge temperature thermostat that is located on the discharge line just below the muffler. The switch shuts off the compressor when the discharge line temperature rises above 250°F ± 5 (121°C ± -2.8) and resets at 200°F + 11 (93°C ± -6.1).

Demand Defrost System

The demand defrost controller uses basic differential temperature means to detect when the system performs poorly because of ice build-up on the outdoor coil. The controller also uses “self-calibrating” principles to calibrate itself when the system starts and after every time the system defrosts. The control board has the following components: defrost relays, anti-short cycle timed-off control, pressure switch/safety control, 5-trip lockout circuit, manufacturing test mode, ambient and coil temperature sensors, field selectable termination temperature pins, and a field low voltage connection terminal strip. See figure 24.

The control monitors ambient temperature, outdoor coil temperature and total run time to determine when a defrost cycle is required. Two temperature probes are permanently attached to the control. The coil temperature probe is designed with a spring clip to allow mounting to the outside coil tubing. The location of the coil sensor is important for proper defrost operation.

NOTE - The logic of the demand defrost board accurately measures the performance of the system as frost accumulates on the outdoor coil. This typically will translate into longer running time between defrost cycles as more frost accumulates on the outdoor coil before the board initiates defrost cycles.

The temperature probes cannot be removed from the control. The control and the attached probes **MUST** be replaced as a unit. Do not attempt to cut or splice probe wires.

Diagnostic LEDs

The defrost board uses two LEDs for diagnostics. The LEDs flash a specific sequence according to the diagnostic condition. See table 10.

HPXA19 Defrost Control Board

Note - Component Locations Will Vary With Board Manufacturer

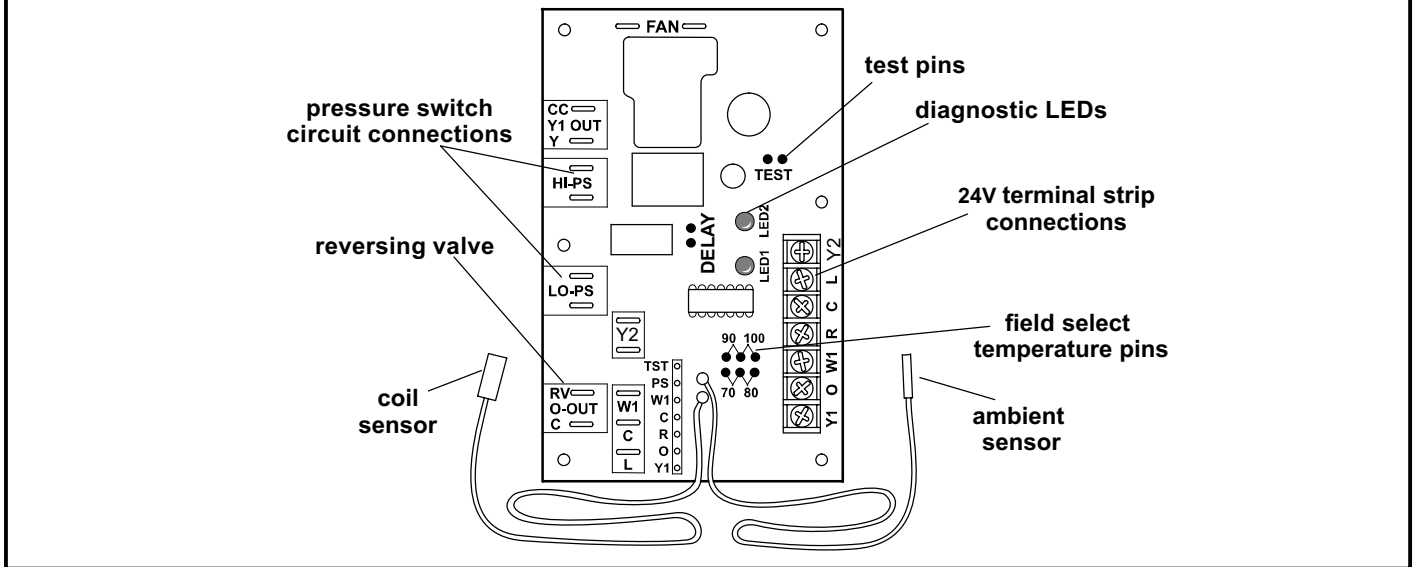

Figure 24

Low Pressure Switch (LO-PS)

The unit's automatic reset low pressure switch (S87) is factory-wired into the defrost board on the LO-PS terminals. When the low pressure switch trips, the defrost board will cycle off the compressor, and the strike counter in the board will count one strike.

(S87) is ignored under the following conditions:

- during the defrost cycle and 90 seconds after the termination of defrost
- when the average ambient sensor temperature is below 15° F (-9°C)
- for 90 seconds following the start up of the compressor
- during "test" mode

High Pressure Switch (HI-PS)

The unit's automatic reset high pressure switch (S4) is factory-wired into the defrost board on the HI-PS terminals. When the high pressure switch trips, the defrost board will cycle off the compressor, and the strike counter in the board will count one strike.

5-Strike Lockout Feature

- The internal control logic of the board counts the pressure switch trips only while the Y1 (Input) line is active. If a pressure switch opens and closes four times during a Y1 (Input), the control logic will reset the pressure switch trip counter to zero at the end of the Y1 (Input). If the pressure switch opens for a fifth time during the current Y1 (Input), the control will enter a lockout condition.
- The 5-strike pressure switch lockout condition can be reset by cycling OFF the 24-volt power to the control board or by shorting the TEST pins. All timer functions (run times) will also be reset.
- If a pressure switch opens while the Y1 Out line is engaged, a 5-minute short cycle will occur after the switch closes.

Delay Mode

The defrost board has a field-selectable function to reduce occasional sounds that may occur while the unit is cycling in and out of the defrost mode. When a jumper is installed on the DELAY pins, the compressor will be cycled off for 30 seconds going in and out of the defrost mode. Units are shipped with jumper installed on DELAY pins.

NOTE - The 30 second off cycle is not functional when jumpering the TEST pins.

Operational Description

The defrost control board has three basic operational modes: normal, defrost, and calibration.

Normal Mode

The demand defrost board monitors the O line, to determine the system operating mode (heat/cool), outdoor ambient temperature, coil temperature (outdoor coil) and compressor run time to determine when a defrost cycle is required.

Defrost Mode

See table 10 for defrost mode and demand defrost operation.

Calibration Mode

The board is considered uncalibrated when power is applied to the board, after cool mode operation, or if the coil temperature exceeds the termination temperature when it is in heat mode.

Calibration of the board occurs after a defrost cycle to ensure that there is no ice on the coil. During calibration, the temperature of both the coil and the ambient sensor are measured to establish the temperature differential which is required to allow a defrost cycle.

Table 10
Defrost Control Board Diagnostic Led (5-Strike)

LED 1	LED 2	Condition	Possible Cause(s)	Solution
OFF	OFF	Power problem	1 No power (24V) to board terminals R & C. 2 Board failure.	1 Check control transformer power (24V). 2 If power is available and LED(s) are unlit, replace board and all sensors.
ON	ON	Coil sensor problem	1 Coil temperature outside of sensor range. 2 Faulty sensor wiring connections at board or poor sensor contact on coil. 3 Sensor failure.	1 Sensor function will resume when coil temperature is between -20°F and 110°F. 2 Check sensor wiring connections at board and sensor contact on coil. 3 Replace board and all sensors.
OFF	ON	Ambient sensor problem	1 Ambient temperature outside of sensor range. 2 Faulty sensor wiring connections at board or sensor. 3 Sensor failure.	1 Sensor function will resume when coil temperature is between -20°F and 110°F. 2 Check sensor wiring connections at board and sensor. 3 Replace board and all sensors.
FLASH	FLASH	Normal operation	Unit operating normally or in standby mode.	None required.
ON	OFF	5-Strike pressure lockout (Short test pins or reset 24V power to board to override lockout)	1 Restricted air flow over indoor or outdoor coil.	1 Remove any blockages or restrictions. Check outdoor fan motor for proper operation.
ON	FLASH	Low pressure switch circuit open during Y1 demand	2 Improper refrigerant charge. 3 Improper metering device operation.	2 Check approach, superheat & sub-cooling temperatures. 3 Check system pressures. Repair leaks. Replace metering device.
FLASH	ON	High pressure switch and/or discharge temperature thermostat circuit open during Y1 demand	4 Poor contact between coil sensor and coil.	4 Make sure that sensor is properly positioned on coil and that firm contact is established. Refer to service manual for proper placement.
ALTERNATING FLASH	ALTERNATING FLASH	5-minute delay (Jumper test pins to override delay)	Thermostat demand for cooling or heat pump operation. Unit operating in 5-minute anti-short-cycle mode.	None required.

Demand Defrost Operation

The demand defrost control board initiates a defrost cycle based on either frost detection or time.

Frost Detection - If the compressor runs longer than 34 minutes and the actual difference between the clear coil and frosted coil temperatures exceeds the maximum difference allowed by the control, a defrost cycle will be initiated.

IMPORTANT - The demand defrost control board will allow a greater accumulation of frost and will initiate fewer defrost cycles than a time/temperature defrost system.

Time - If 6 hours of heating mode compressor run time has elapsed since the last defrost cycle while the coil temperature remains below 35°F (2°C), the demand defrost control will initiate a defrost cycle.

Actuation - When the reversing valve is de-energized, the Y1 circuit is energized, and the coil temperature is below 35°F (2°C), the board logs the compressor run time. If the board is not calibrated, a defrost cycle will be initiated after 34 minutes of heating mode compressor run time. The control will attempt to self-calibrate after this (and all other) defrost cycle(s). Calibration success depends on stable system temperatures during the 20-minute calibration period. If the board fails to calibrate, another defrost cycle will be initiated after 90 minutes of heating mode compressor run time. Once the defrost board is calibrated, it will use demand defrost logic to initiate a defrost cycle. A demand defrost system initiates defrost when the difference between the clear coil and frosted coil temperatures exceeds the maximum difference allowed by the control OR after 6 hours of heating mode compressor run time has been logged since the last defrost cycle.

Termination - The defrost cycle ends when the coil temperature exceeds the termination temperature or after 14 minutes of defrost operation. If the defrost is terminated by the 14-minute timer, another defrost cycle will be initiated after 34 minutes of run time.

Test Mode - When Y1 is energized and 24V power is being applied to the board, a test cycle can be initiated by placing the termination temperature jumper across the "Test" pins for 2 to 5 seconds. If the jumper remains across the "Test" pins longer than 5 seconds, the control will ignore the test pins and revert to normal operation. The jumper will initiate one cycle per test.

Maintenance

Before the start of each heating and cooling season, the following service checks should be performed by a qualified service technician.

Electrical power to the unit must be turned off prior to any unit maintenance.

⚠ WARNING



Electric shock hazard. Can cause injury or death. Before attempting to perform any service or maintenance, turn the electrical power to unit OFF at disconnect switch(es). Unit may have multiple power supplies.

Outdoor Unit

- The outdoor and indoor coils should be inspected and cleaned. The outdoor coil may be flushed with a water hose.

NOTE - It may be necessary to flush the outdoor coil more frequently if it is exposed to substances which are corrosive or which block airflow across the coil (e.g., pet urine, cottonwood seeds, etc.)

- The refrigerant lines should be visually inspected and the coils should be checked for leaks.
- Wiring should be checked for loose connections.
- Voltage must be checked at the indoor and outdoor units (units operating).
- The amp-draw at the outdoor fan motor, compressor, and indoor blower motor should be checked. Values should be compared with those given on unit nameplate.
- Indoor unit filters should be cleaned or replaced.
- The refrigerant charge should be checked and system pressures should be gauged.
- The condensate drain line should be checked for free and unobstructed flow and it should be cleaned, if necessary.
- Outdoor unit fan motor is prelubricated and sealed. No further lubrication is needed.

NOTE - If owner complains of insufficient cooling, the unit should be gauged and refrigerant charge checked. Refer to section on refrigerant charging in this instruction.

Optional Accessories

Refer to the Engineering Handbook for optional accessories that may apply to this unit. The following may or may not apply:

- Loss of Charge Kit
- High Pressure Switch Kit
- Compressor Monitor
- Compressor Crankcase Heater
- Hail Guards
- Mounting Bases
- Timed Off Control
- Stand-off Kit
- Sound Cover
- Low Ambient Kit
- Monitor Kit
- Dave Lennox *Signature Stat*™ Room Thermostat

Homeowner Information

In order to ensure peak performance, your system must be properly maintained. Clogged filters and blocked airflow prevent your unit from operating at its most efficient level.

Ask your Lennox dealer to show you where your indoor unit's filter is located. It will be either at the indoor unit (installed internal or external to the cabinet) or behind a return air grille in the wall or ceiling. Check the filter monthly and clean or replace it as needed.

Disposable filters should be replaced with a filter of the same type and size. If you are unsure about the filter you need for your system, call your Lennox dealer for assistance.

IMPORTANT

Turn off electrical power to the unit at the disconnect switch before performing any maintenance. The unit may have multiple power supplies.

Many indoor units are equipped with reusable foam filters. These filters can be cleaned with a mild soap and water solution. Rinse the filter thoroughly and let it dry completely before it is returned to the unit or grille.

The filter and all access panels must be in place any time the unit is in operation.

Your system may be equipped with an electronic air cleaner which will provide respiratory relief by removing up to 90 percent of all airborne particles which pass through it. If it is, ask your dealer to instruct you on its maintenance.

Your indoor evaporator coil is equipped with a drain pan to collect condensate formed as your system removes humidity from the inside air. Have your dealer show you where the main condensate drain (and auxiliary drain, if applicable) runs and how to check the drain for any obstruction.

It is also very important to provide unrestricted airflow to the outdoor unit. Leaves, trash or shrubs crowding the unit cause the outdoor unit to work harder and use more energy. Keep shrubbery trimmed away from the unit and periodically check for debris which may have collected around the unit.

Heat Pump Operation

Your new Lennox heat pump has several characteristics that you should be aware of:

Your heat pump satisfies heating demand by delivering large amounts of warm air into the living space. This is quite different from gas- or oil-fired furnaces or an electric furnace which deliver lower volumes of considerably hotter air to heat the space.

Do not be alarmed if you notice frost on the outdoor coil in the winter months. Frost develops on the outdoor coil during the heating cycle when temperatures are below 45°F (7°C). An electronic control activates a defrost cycle lasting 5 to 15 minutes at preset intervals to clear the outdoor coil of the frost. During the defrost cycle, you may notice steam rising from the outdoor unit. This is a normal occurrence. The thermostat may engage auxiliary heat during the defrost cycle to satisfy a heating demand; however, the unit will return to normal operation at the conclusion of the defrost cycle.

Your Lennox HPXA19 heat pump is equipped with a compressor crankcase heater which protects the compressor from refrigerant slugging during cold weather operation. If power to your unit has been interrupted for several hours or more, set the room thermostat selector

to the "Emergency Heat" setting to obtain temporary heat without the risk of serious equipment damage. In this operating mode, all heating demand will be satisfied by auxiliary heat. Compressor operation is locked out during Emergency Heat operation. After a six-hour compressor crankcase heater warm-up period, the thermostat can be switched to the "Heat" setting and normal operation will resume.

Thermostat Operation

Though your thermostat may vary somewhat from the description below, its operation will be similar.

Temperature Setting Levers

Most heat pump thermostats have two temperature selector levers: one for heating and one for cooling. Set the levers or dials to the desired temperature setpoints for both heating and cooling. Avoid frequent temperature adjustment; turning the unit off and back on before pressures equalize puts stress on the unit compressor.

Fan Switch

In AUTO or INT (intermittent) mode, the blower operates only when the thermostat calls for heating or cooling. This mode is generally preferred when humidity control is a priority. The ON or CONT mode provides continuous indoor blower operation, regardless of whether the compressor or auxiliary heat are operating. This mode is required when constant air circulation or filtering is desired.

System Switch

Set the system switch for heating, cooling or auto operation. The auto mode allows the heat pump to automatically switch from heating mode to cooling mode to maintain predetermined comfort settings. Many heat pump thermostats are also equipped with an emergency heat

mode which locks out heat pump operation and provides temporary heat supplied by the auxiliary heat.

Indicating Light

Most heat pump thermostats have an amber light which indicates when the heat pump is operating in the emergency heat mode.

Temperature Indicator

The temperature indicator displays the actual room temperature.

Programmable Thermostats

Your Lennox system may be controlled by a programmable thermostat. These thermostats provide the added feature of programmable time-of-day setpoints for both heating and cooling. Refer to the user's information manual provided with your particular thermostat for operation details.

Preservice Check

If your system fails to operate, check the following before calling for service:

- Check to see that all electrical disconnect switches are ON.
- Make sure the room thermostat temperature selector is properly set.
- Make sure the room thermostat system switch is properly set.
- Replace any blown fuses, or reset circuit breakers.
- Make sure unit access panels are in place.
- Make sure air filter is clean.
- Locate unit model number and have it handy before calling.

Check Points

Start-up and Performance Check List			
Job Name _____	Job No. _____	Date _____	
Job Location _____	City _____	State _____	
Installer _____	City _____	State _____	
Unit Model No. _____	Serial No. _____	Service Technician _____	
Nameplate Voltage _____			
Rated Load Ampacity _____	Amps: 1st stage _____	2nd Stage _____	
Maximum Fuse or Circuit Breaker _____			
Electrical Connections Tight? <input type="checkbox"/>	Indoor Filter Clean? <input type="checkbox"/>	Supply Voltage (Unit Off) _____	
Indoor Blower RPM _____	S.P. Drop Over Indoor (Dry) _____	Outdoor Coil Entering Air Temp. _____	
Cooling (2nd stage)			
Liquid Line Pressure _____	Vapor Pressure _____	Refrigerant Charge Checked? <input type="checkbox"/>	
Heating (2nd stage)			
Liquid Line Pressure _____	Vapor Pressure _____	Refrigerant Charge Checked? <input type="checkbox"/>	
Refrigerant Lines: Leak Checked? <input type="checkbox"/>	Properly Insulated? <input type="checkbox"/>	Outdoor Fan Checked? <input type="checkbox"/>	
Service Valves Fully Opened? <input type="checkbox"/>	Service Valve Caps Tight? <input type="checkbox"/>	Voltage With Compressor Operating _____	
Sequence of Operation			
Heating Correct <input type="checkbox"/>	Cooling Correct <input type="checkbox"/>	Thermostat	
		Calibrated? <input type="checkbox"/>	Properly Set? <input type="checkbox"/> Level? <input type="checkbox"/>