



# ***MULTI V***™ **5** **SERVICE MANUAL**

Variable Refrigerant Flow Outdoor Units  
6.0 to 42.0 Tons



## PROPRIETARY DATA NOTICE

**This document, as well as all reports, illustrations, data, information, and other materials are the property of LG Electronics U.S.A., Inc., and are disclosed by LG Electronics U.S.A., Inc. only in confidence.**

** Do not throw away, destroy, or lose this manual.  
Please read carefully and store in a safe place for future reference.  
Content familiarity is required for proper installation.**





The instructions included in this manual must be followed to prevent product malfunction, property damage, injury, or death to the user or other people. Incorrect operation due to ignoring any instructions will cause harm or damage. The level of seriousness is classified by the symbols described by the summary list of safety precautions on page 4.

**For more technical materials such as submittals, catalogs, engineering, installation, best practices, and owner's manuals, visit [www.lghvac.com](http://www.lghvac.com).**

Safety Precautions .....	4-7	Troubleshooting Main Components .....	111-124
Nomenclature.....	8	<i>Test Run</i> .....	111
Wiring Diagrams .....	9-16	<i>Main Component Errors</i> .....	112
Refrigerant Flow Diagrams.....	17-42	<i>Self Diagnostics Check</i> .....	113
<b>Outdoor Unit Functions</b> .....	<b>43-87</b>	<i>Checking the Compressor</i> .....	114-115
<i>Basic Control</i> .....	43-44	<i>Checking the Outdoor Unit Fan Motor</i> .....	115
<i>Normal Operation/Compressor Control</i> .....	43	<i>Checking the Electronic Expansion Valves</i> .....	116-118
<i>Master-Slave EEVs/Fan Motor Control</i> .....	44	<i>Checking the Phase Bridge Diode</i> .....	119
<i>Special Control</i> .....	45-47	<i>Checking the Inverter IPM / IGBT</i> .....	120
<i>Oil Return Control</i> .....	45	<i>Checking the Fan IPM</i> .....	121
<i>Defrost Control / Partial Defrost Control</i> .....	46	<i>Checking the High / Low Pressure Sensors</i> .....	122
<i>Stop Operation / Oil Equalizing</i> .....	47	<i>Checking the Outdoor Fan</i> .....	122
<i>Protection Control</i> .....	48-49	<i>Checking the Valves</i> .....	123-124
<i>Pressure Protection Control</i> .....	48	<b>Error Codes</b> .....	<b>125-216</b>
<i>Discharge Temperature/Inverter Protection</i> .....	49	<i>Error Code General Information</i> .....	125
<i>Other Controls</i> .....	50-53	<i>Error Code Tables</i> .....	126-135
<i>Initial Setup</i> .....	50-53	<i>Error Codes</i> .....	136-208
<i>Quick Control</i> .....	53	<i>Replacing the Inverter PCB Heat Sink</i> .....	209
<i>Setting Optional Modes</i> .....	54-87	<i>Checking Input Voltage in Case of Power On</i> .....	210
<b>Heat Recovery Units</b> .....	<b>88-95</b>	<i>Checking Main PCB DC Voltage in Case of Power On</i> .....	211
<i>Parts Functions</i> .....	88	<i>Checking Converter DC Link Voltage in Case of</i> <i>Compressor Operating</i> .....	212
<i>Dimensional Diagrams</i> .....	89-91	<i>Checking ODU to ODU Comm. (DC Voltage) in</i> <i>Case of Power On</i> .....	213
<i>Wiring Diagram</i> .....	92	<i>Checking Inverter PCB in Case of Power Off</i> .....	214
<i>Refrigerant Circuit Diagram</i> .....	93	<i>Power System Wiring Diagram</i> .....	215
<i>Functions</i> .....	94-95	<i>PCB Locations</i> .....	216
<b>PCB Settings</b> .....	<b>96-110</b>	<b>Parts</b> .....	<b>217-234</b>
<i>Outdoor Unit DIP Switch Settings</i> .....	96	<i>PCBs</i> .....	217-225
<i>Heat Recovery Unit Settings</i> .....	97-102	<i>PCBs - Expanded Internal View</i> .....	226-228
<i>Indoor Unit Addressing</i> .....	103-104	<i>Expanded Frame View</i> .....	229-234
<i>Pipe Detection Addressing</i> .....	105-110		

The instructions below must be followed to prevent product malfunction, property damage, injury or death to the user or other people. Incorrect operation due to ignoring any instructions will cause harm or damage. The level of seriousness is classified by the symbols described below.

## TABLE OF SYMBOLS

 <b>DANGER</b>	<i>This symbol indicates an imminently hazardous situation which, if not avoided, will result in death or serious injury.</i>
 <b>WARNING</b>	<i>This symbol indicates a potentially hazardous situation which, if not avoided, could result in death or serious injury.</i>
 <b>CAUTION</b>	<i>This symbol indicates a potentially hazardous situation which, if not avoided, may result in minor or moderate injury.</i>
<b>Note:</b>	<i>This symbol indicates situations that may result in equipment or property damage accidents only.</i>
	<i>This symbol indicates an action that should not be performed.</i>

## INSTALLATION

### DANGER

 Do not store or use flammable gas or combustibles near the unit.  
*There is risk of fire, explosion, and physical injury or death.*

 Do not supply power to the unit until all wiring and piping are completed or reconnected and checked.  
*There is risk of physical injury or death due to electric shock.*

### WARNING

 Do not install or remove the unit by yourself (end user). Ask the dealer or an LG trained technician to install the unit.  
*Improper installation by the user will result in fire, explosion, electric shock, physical injury or death.*

**For replacement of an installed unit, always contact an LG trained service provider.**  
*There is risk of fire, electric shock, explosion, and physical injury or death.*

**Wear protective gloves when handling equipment. Sharp edges will cause personal injury.**

 Do not change the settings of the protection devices.  
*If the protection devices have been bypassed or are forced to operate improperly, or parts other than those specified by LG are used, there is risk of fire, electric shock, explosion, and physical injury or death.*

**Replace all control box and panel covers.**  
*If cover panels are not securely installed, dust, water, and animals will enter the outdoor unit, causing fire, electric shock, and physical injury or death.*

**Always check for system refrigerant leaks after the unit has been installed or serviced.**  
*Exposure to high concentration levels of refrigerant gas will lead to illness or death.*

**Periodically check that the outdoor frame is not damaged.**  
*There is a risk of explosion, physical injury, or death.*

**If the air conditioner is installed in a small space, take measures to prevent the refrigerant concentration from exceeding safety limits in the event of a refrigerant leak.**  
*Consult the latest edition of American Society of Heating, Refrigerating, and Air Conditioning Engineers (ASHRAE) Standard 15. If the refrigerant leaks and safety limits are exceeded, it could result in personal injuries or death from oxygen depletion.*

**The heat recovery unit must be installed indoors;  do not install the heat recovery unit in a highly humid environment.**  
*There is risk of physical injury or death due to electric shock.*

**Dispose of the packing materials safely.**

- Packing materials, such as nails and other metal or wooden parts, will cause puncture wounds or other injuries.
- Tear apart and throw away plastic packaging bags so that children will not play with them and risk suffocation and death.

**Install the unit considering the potential for strong winds or earthquakes.**  
*Improper installation will cause the unit to fall over, resulting in physical injury or death.*

**Install the unit in a safe location where nobody can step, fall onto it, or place objects on it.  Do not install the unit on a defective stand.**  
*It will result in an accident that causes physical injury or death.*

**⚠ WARNING**

**Properly insulate all cold surfaces to prevent “sweating.”**

*Cold surfaces such as uninsulated piping can generate condensate that could drip, causing a slippery surface that creates a risk of slipping, falling, and personal injury.*

**⚠ CAUTION**

**Be very careful when transporting the product. There is a risk of the product falling and causing physical injury.**

- Use appropriate moving equipment to transport each frame; ensure the equipment is capable of supporting the weights listed.
- Some products use polypropylene bands for packaging. Ⓣ Do not use polypropylene bands to lift the unit.
- Suspend the outdoor unit from the base at specified positions (at a minimum of six [6] points) to avoid slippage from rigging apparatus.

**Note:**

**LG Electronics U.S.A., Inc., is not responsible for any piping calculations, refrigerant leaks, degradation of performance, or any other potential problems or damages as a result of interconnecting piping, their joint connections, isolation valves, introduced debris inside the piping system, or other problems caused by the interconnecting piping system.**

Ⓣ Do not install the product where it is exposed directly to ocean winds.

*Sea salt in the air will cause the product to corrode. Corrosion, particularly on the condenser and evaporator fins, could cause product malfunction or inefficient operation.*

**When installing the outdoor unit in a low-lying area, or a location that is not level, use a raised concrete pad or concrete blocks to provide a solid, level foundation.**

*This prevents water damage and abnormal vibration.*

**Properly insulate all cold surfaces to prevent “sweating.”**

*Cold surfaces such as uninsulated piping can generate condensate that will drip and cause a slippery surface condition and / or water damage to walls.*

**Always check for system refrigerant leaks after the unit has been installed or serviced.**

*Low refrigerant levels will cause product failure.*

Ⓣ Do not make refrigerant substitutions. Use R410A only.

*If a different refrigerant is used, or air mixes with original refrigerant, the unit will malfunction and damage will occur.*

Ⓣ Do not store or use flammable gas / combustibles near the unit.

*There is a risk of product failure.*

Ⓣ Do not use the product for mission critical or special purpose applications such as preserving foods, works of art, or other precision air conditioning applications. The equipment is designed to provide comfort cooling and heating.

*There is risk of property damage.*

**Keep the unit upright during installation to avoid vibration or water leakage.**

**When installing the unit in a hospital, mechanical room, or similar electromagnetic field (EMF) sensitive environment, provide sufficient protection against electrical noise.**

*Inverter equipment, power generators, high-frequency medical equipment or radio communication equipment will cause the air conditioner to operate improperly. The unit will also affect such equipment by creating electrical noise that disturbs medical treatment or image broadcasting.*

**The heat recovery box must be installed indoors; Ⓣ do not install the heat recovery box in a highly humid environment.**

*There is risk of product failure and property damage.*

**When connecting refrigerant piping, remember to allow for pipe expansion.**

*Improper piping installation will cause system malfunction.*

Ⓣ Do not install the outdoor unit or heat recovery unit in a noise-sensitive area.

**Take appropriate actions at the end of HVAC equipment life to recover, recycle, reclaim, or destroy R410A refrigerant according to applicable U.S. Environmental Protection Agency (EPA) rules.**

**Periodically check that the outdoor frame is not damaged.**

*There is a risk of equipment damage.*

**Install the unit in a safe location where no one can step on or fall onto it. Ⓣ Do not install the unit on a defective stand.**

*There is a risk of unit and property damage.*

**Install the drain hose to ensure adequate drainage.**

*There is a risk of water leakage and property damage.*

## WIRING

### **⚠ DANGER**

**High voltage electricity is required to operate this system. Adhere to the U.S. National Electric Codes (NEC) and these instructions when wiring.**

*Improper connections and inadequate grounding can cause accidental injury or death.*

**Always ground the unit following local, state, and NEC codes.**  
*There is risk of fire, electric shock, and physical injury or death.*

**Turn the power off at the nearest disconnect before servicing the equipment.**

*Electrical shock can cause physical injury or death.*

**Properly size all circuit breakers or fuses.**

*There is risk of fire, electric shock, explosion, physical injury or death.*

⊘ **Do not share the electrical circuit with other devices.**

*There is risk of fire, electric shock, and physical injury or death due to heat generation.*

⊘ **Do not use damaged or loose power wiring.** ⊘ **Do not modify or extend the outdoor unit's power wiring. Ensure that the power wiring will not be pulled nor weight be placed on the power wiring during operation.**

*There is risk of fire, electric shock, and physical injury or death.*

### **⚠ WARNING**

**The information contained in this manual is intended for use by an industry-qualified, experienced, trained electrician familiar with the NEC who is equipped with the proper tools and test instruments.**

*Failure to carefully read and follow all instructions in this manual can result in personal injury or death.*

**All electric work must be performed by a licensed electrician and conform to local building codes or, in the absence of local codes, with the NEC, and the instructions given in this manual.**

*If the power source capacity is inadequate or the electric work is not performed properly, it will result in fire, electric shock, physical injury or death.*

**Refer to local, state, and federal codes, and use power wires of sufficient current capacity and rating.**

*Wires that are too small will generate heat and cause a fire, and physical injury or death.*

**Secure all field wiring connections with appropriate wire strain relief.**

*Improperly securing wires will create undue stress on equipment power connections. Inadequate connections will generate heat, cause a fire, and physical injury or death.*

**Ensure the system is connected to a dedicated power source that provides adequate power.**

*If the power source capacity is inadequate or the electric work is not performed properly, it will result in fire, electric shock, physical injury or death.*

**Properly tighten all power connections.**

*Loose wiring will overheat at connection points, causing a fire, physical injury or death.*

⊘ **Do not change the settings of the protection devices.**

*If the protection devices have been bypassed or is forced to operate improperly, or parts other than those specified by LG are used, there is risk of fire, electric shock, explosion, and physical injury or death.*

### **Note:**

⊘ **Do not supply power to the unit until all electrical wiring, controls wiring, piping, installation, and refrigerant system evacuation are completed.**

*The system will malfunction.*

**The information contained in this manual is intended for use by an industry-qualified, experienced, licensed electrician familiar with the NEC who is equipped with the proper tools and test instruments.**

*Failure to carefully read and follow all instructions in this manual can result in equipment malfunction and property damage.*

**OPERATION**

**⚠ DANGER**

⊘ Do not provide power to or operate the unit if it is flooded or submerged.

*There is risk of fire, electric shock, physical injury or death.*

**Use a dedicated breaker for this product.**

*There is risk of fire, electric shock, physical injury or death.*

⊘ Do not operate the disconnect switch with wet hands.

*There is risk of fire, electric shock, physical injury or death.*

**Periodically verify the equipment mounts have not deteriorated.**

*If the base collapses, the unit could fall and cause physical injury or death.*

**Use inert (nitrogen) gas when performing leak tests or air purges.** ⊘ Do not use compressed air, oxygen, or flammable gases.

*Using these substances will cause fire, explosion, and physical injury or death.*

**If refrigerant leaks out, ventilate the area before operating the unit.**

*If the unit is mounted in an enclosed, low-lying, or poorly ventilated area, and the system develops a refrigerant leak, it will cause a fire, electric shock, explosion, physical injury or death.*

**⚠ WARNING**

⊘ Do not allow water, dirt, or animals to enter the unit.

*There is risk of fire, electric shock, physical injury or death.*

⊘ Do not operate the unit with the panel(s) or protective cover(s) removed; keep fingers and clothing away from moving parts.

*The rotating, hot, cold, and high-voltage parts of the unit can cause physical injury or death.*

⊘ Do not touch the refrigerant piping during or after operation.

*It can cause burns or frostbite.*

⊘ Do not open the inlet during operation.

*There is risk of electric shock, physical injury or death.*

**⚠ CAUTION**

⊘ To avoid physical injury, use caution when cleaning or servicing the air conditioner.

*There is risk of electric shock, physical injury or death.*

**Note:**

**Clean up the site after servicing is finished, and check that no metal scraps, screws, or bits of wiring have been left inside or surrounding the unit.**

⊘ Do not use the product for mission critical or special purpose applications such as preserving food, works of art, or other precision air conditioning applications. The equipment is designed to provide comfort cooling and heating.

*There is risk of property damage.*

⊘ Do not allow water, dirt, or animals to enter the unit.

*There is risk of unit failure.*

⊘ Do not open the inlet during operation.

*There is risk of unit failure.*

⊘ Do not operate the unit with the panel(s) or protective cover(s) removed; keep fingers and clothing away from moving parts.

*Non-secured covers can result in malfunction due to dust or water in the service panel.*

**Periodically verify the equipment mounts have not deteriorated.**

*If the base collapses, the unit could fall and cause property damage or product failure.*

**Use only a soft cloth to clean the air conditioner.** ⊘ Do not use wax, thinner, or strong detergents.

*Strong cleaning products will damage the surface of the air conditioner, or will cause its appearance to deteriorate.*

**Provide power to the outdoor unit to warm the compressor crankcase at least six (6) hours before operation begins.**

*Starting operation with a cold compressor sump(s) will result in severe bearing damage to the compressor(s). Keep the power switch on during the operational season.*

⊘ Do not turn off the main power switch after operation has been stopped.

*Wait at least five (5) minutes before turning off the main power switch, otherwise it will result in product malfunction.*

⊘ Do not block the inlet or outlet.

*Unit will malfunction.*

**Auto-addressing must be performed after connecting the power of all indoor and outdoor units.**

*Auto-addressing must also be performed after servicing an indoor unit.*

# UNIT NOMENCLATURE

## Outdoor Units and Heat Recovery Units

### Outdoor Units (ODU)

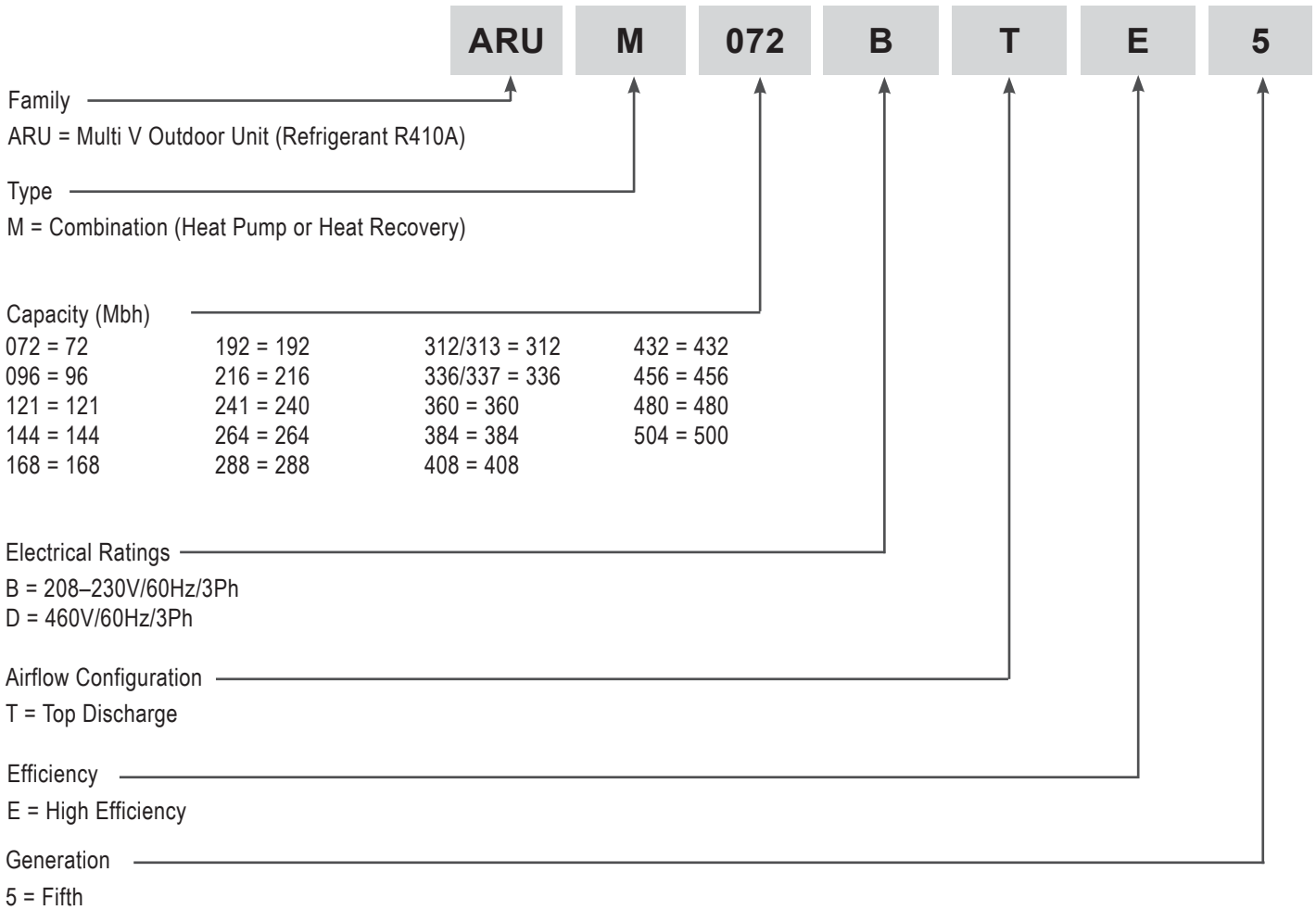

### Heat Recovery Units (HRU)

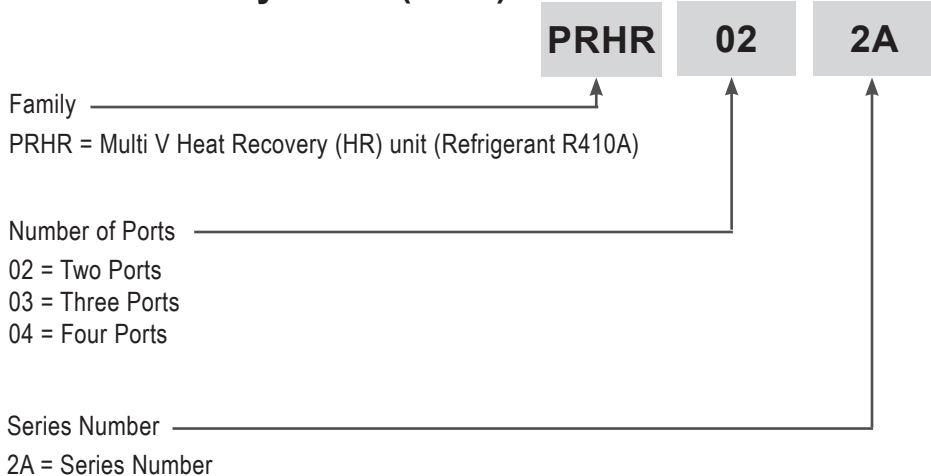

MULTI V 5 Outdoor Unit Service Manual

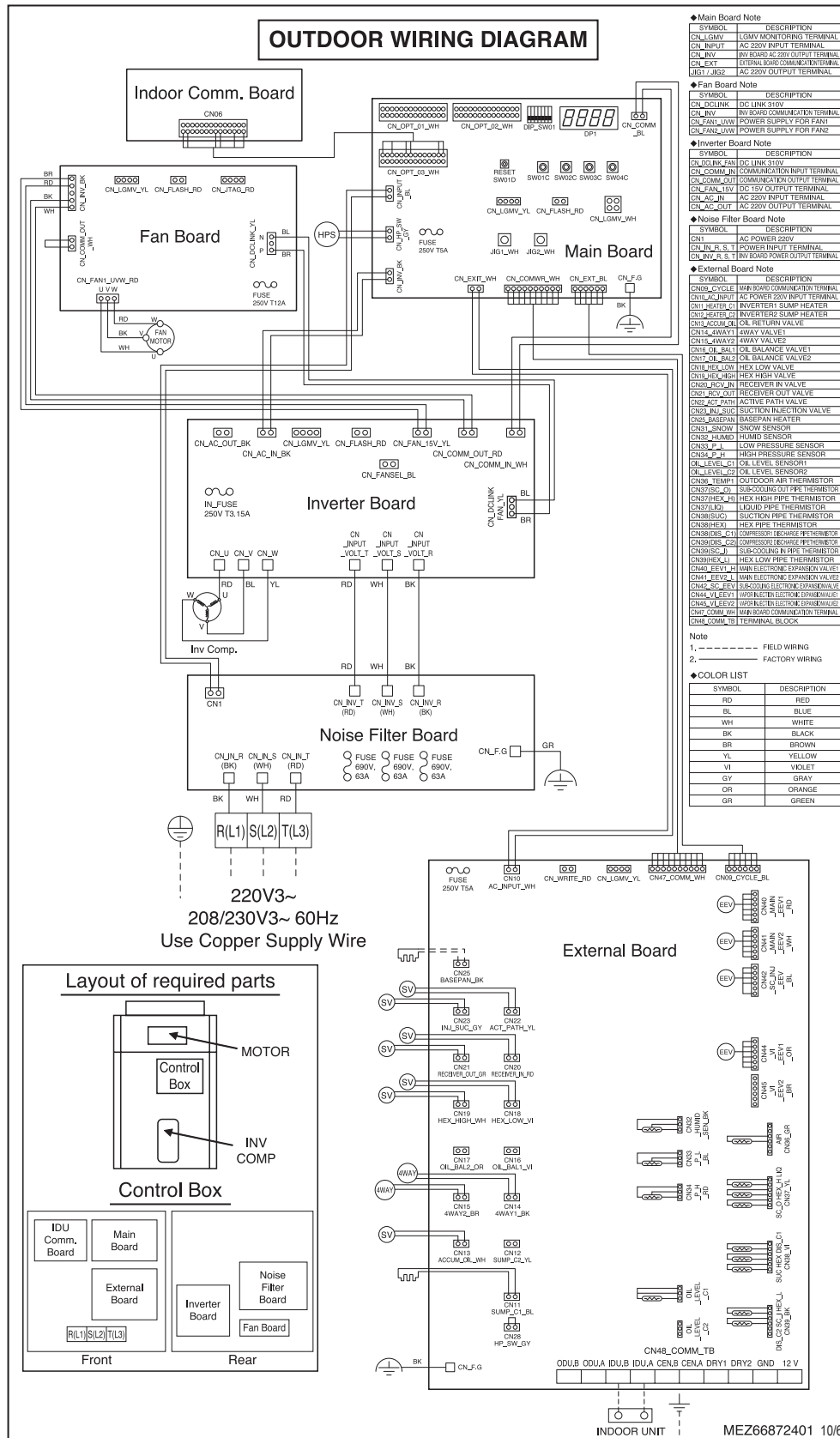

# WIRING DIAGRAMS

208-230V Outdoor Units

ARUM096BTE5 / ARUM121BTE5

MULTI V 5 Outdoor Unit Service Manual

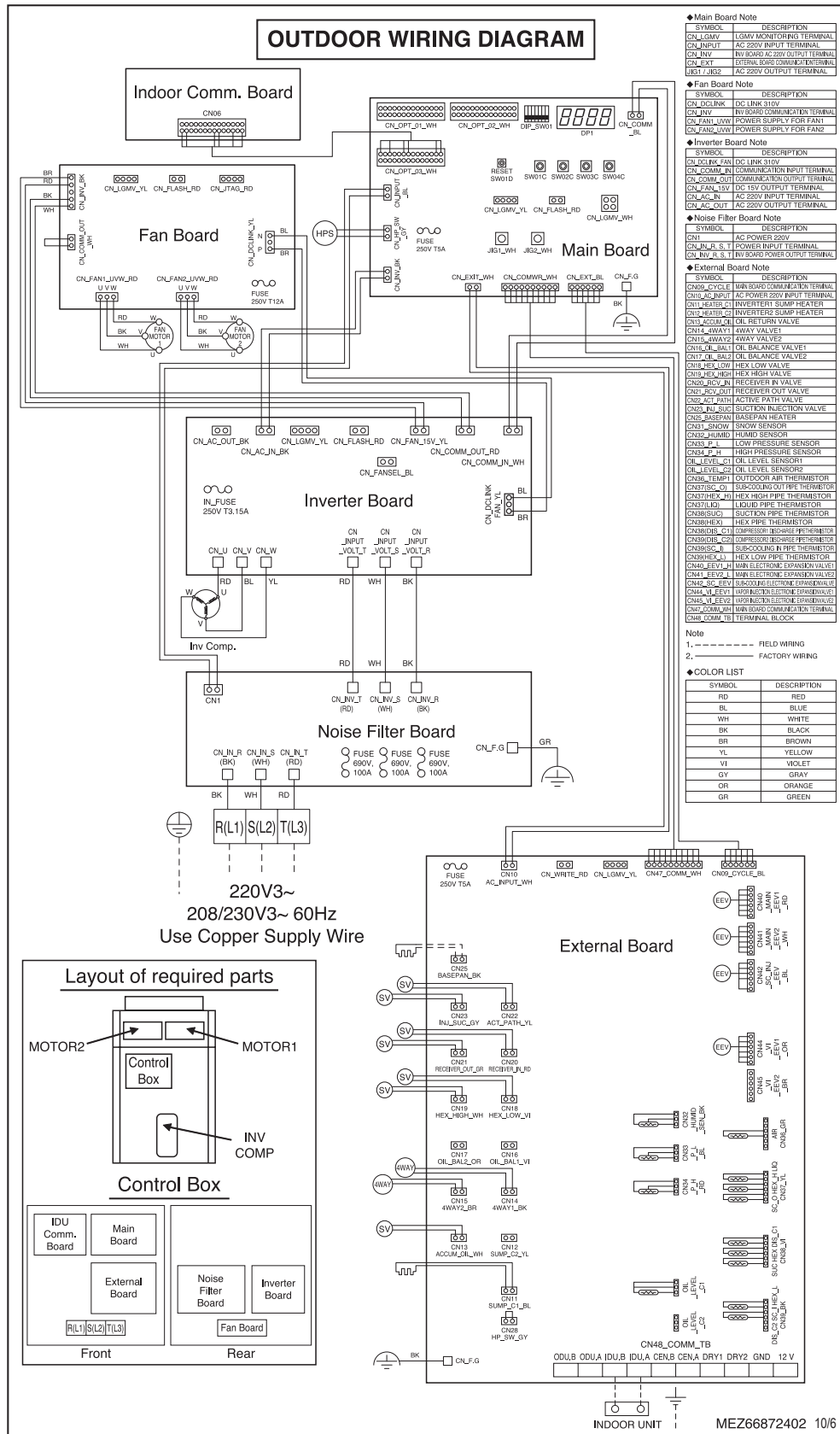

- ◆Main Board Note
- | SYMBOL    | DESCRIPTION                           |
|-----------|---------------------------------------|
| CN1_GM_V  | LGWV MONITORING TERMINAL              |
| CN1_INP   | AC 230V INPUT TERMINAL                |
| CN1_INV   | RV BOARD AC 230V OUTPUT TERMINAL      |
| CN1_EXT   | EXTERNAL BOARD COMMUNICATION TERMINAL |
| J101_J102 | AC 230V OUTPUT TERMINAL               |
- ◆Fan Board Note
- | SYMBOL     | DESCRIPTION                     |
|------------|---------------------------------|
| CN1_DCLINK | DC LINK 310V                    |
| CN1_INV    | RV BOARD COMMUNICATION TERMINAL |
| CN1_FAN1_L | POWER SUPPLY FOR FAN1           |
| CN1_FAN2_L | POWER SUPPLY FOR FAN2           |
- ◆Inverter Board Note
- | SYMBOL         | DESCRIPTION                   |
|----------------|-------------------------------|
| CN1_DCLINK_FAN | DC LINK 310V                  |
| CN1_COMM_IN    | COMMUNICATION INPUT TERMINAL  |
| CN1_COMM_OUT   | COMMUNICATION OUTPUT TERMINAL |
| CN1_FAN1_12V   | DC 12V OUTPUT TERMINAL        |
| CN1_AC_IN      | AC 230V INPUT TERMINAL        |
| CN1_AC_OUT     | AC 230V OUTPUT TERMINAL       |
- ◆Noise Filter Board Note
- | SYMBOL      | DESCRIPTION                    |
|-------------|--------------------------------|
| CN1         | AC POWER 230V                  |
| CN1_N_R_S_T | POWER INPUT TERMINAL           |
| CN1_INV_S_T | RV BOARD POWER OUTPUT TERMINAL |
- ◆External Board Note
- | SYMBOL        | DESCRIPTION                        |
|---------------|------------------------------------|
| CN49_CYCLE    | MAIN BOARD COMMUNICATION TERMINAL  |
| CN125_INP     | AC POWER 230V INPUT TERMINAL       |
| CN1_HEATER_C1 | INVERTER SUMP HEATER               |
| CN1_HEATER_C2 | INVERTER SUMP HEATER               |
| CN135_OIL     | OIL RETURN VALVE                   |
| CN14_4WAY1    | 4WAY VALVE1                        |
| CN15_4WAY2    | 4WAY VALVE2                        |
| CN16_OIL_BAL1 | OIL BALANCE VALVE1                 |
| CN17_OIL_BAL2 | OIL BALANCE VALVE2                 |
| CN18_HEX_LOW  | HEX LOW VALVE                      |
| CN19_HEX_HIGH | HEX HIGH VALVE                     |
| CN20_RCV_IN   | RECEIVER IN VALVE                  |
| CN21_RCV_OUT  | RECEIVER OUT VALVE                 |
| CN22_PATH     | ACTIVE PATH VALVE                  |
| CN23_FU_SUC   | SUCTION INJECTION VALVE            |
| CN1300_FAN    | MAIN FAN HEATER                    |
| CN131_SNOW    | SNOW SENSOR                        |
| CN132_HUMID   | HUMID SENSOR                       |
| CN133_P1      | LOW PRESSURE SENSOR                |
| CN134_P_H     | HIGH PRESSURE SENSOR               |
| OIL_LEVEL_C1  | OIL LEVEL SENSOR1                  |
| CN136_TEMP1   | OUTDOOR AIR THERMISTOR             |
| CN137_TEMP_C1 | SUBCOOLING OUT PIPE THERMISTOR     |
| CN137_TEMP_C2 | HEX HIGH PIPE THERMISTOR           |
| CN137_TEMP_C3 | LIQUID PIPE THERMISTOR             |
| CN138_SUC     | SUCTION PIPE THERMISTOR            |
| CN139_HEX     | HEX PIPE THERMISTOR                |
| CN138(OBS_C1) | COMPRESSOR HEADPIPE THERMISTOR     |
| CN139(OBS_C2) | COMPRESSOR THERMISTOR              |
| CN139(OBS_C3) | SUB-COOLING N PIPE THERMISTOR      |
| CN139(OBS_C4) | HEX LOW PIPE THERMISTOR            |
| CN140_EEV_1   | MAN-ELECTRONIC EXPANSION VALVE     |
| CN141_EEV_2   | MAN-ELECTRONIC EXPANSION VALVE     |
| CN142_EEV_3   | SUBCOOLING SECTION EXPANSION VALVE |
| CN143_EEV_1   | UPPER REFRIGERATOR EXPANSION VALVE |
| CN143_EEV_2   | UPPER REFRIGERATOR EXPANSION VALVE |
| CN1_COMM_IN   | MAIN BOARD COMMUNICATION TERMINAL  |
| CN1300_COMM   | TERMINAL BLOCK                     |
- Note
1. --- FIELD WIRING  
2. --- FACTORY WIRING
- ◆COLOR LIST
- | SYMBOL | DESCRIPTION |
|--------|-------------|
| RD     | RED         |
| BL     | BLUE        |
| WH     | WHITE       |
| BK     | BLACK       |
| BR     | BROWN       |
| YL     | YELLOW      |
| VI     | VIOLET      |
| GY     | GRAY        |
| OR     | ORANGE      |
| GR     | GREEN       |

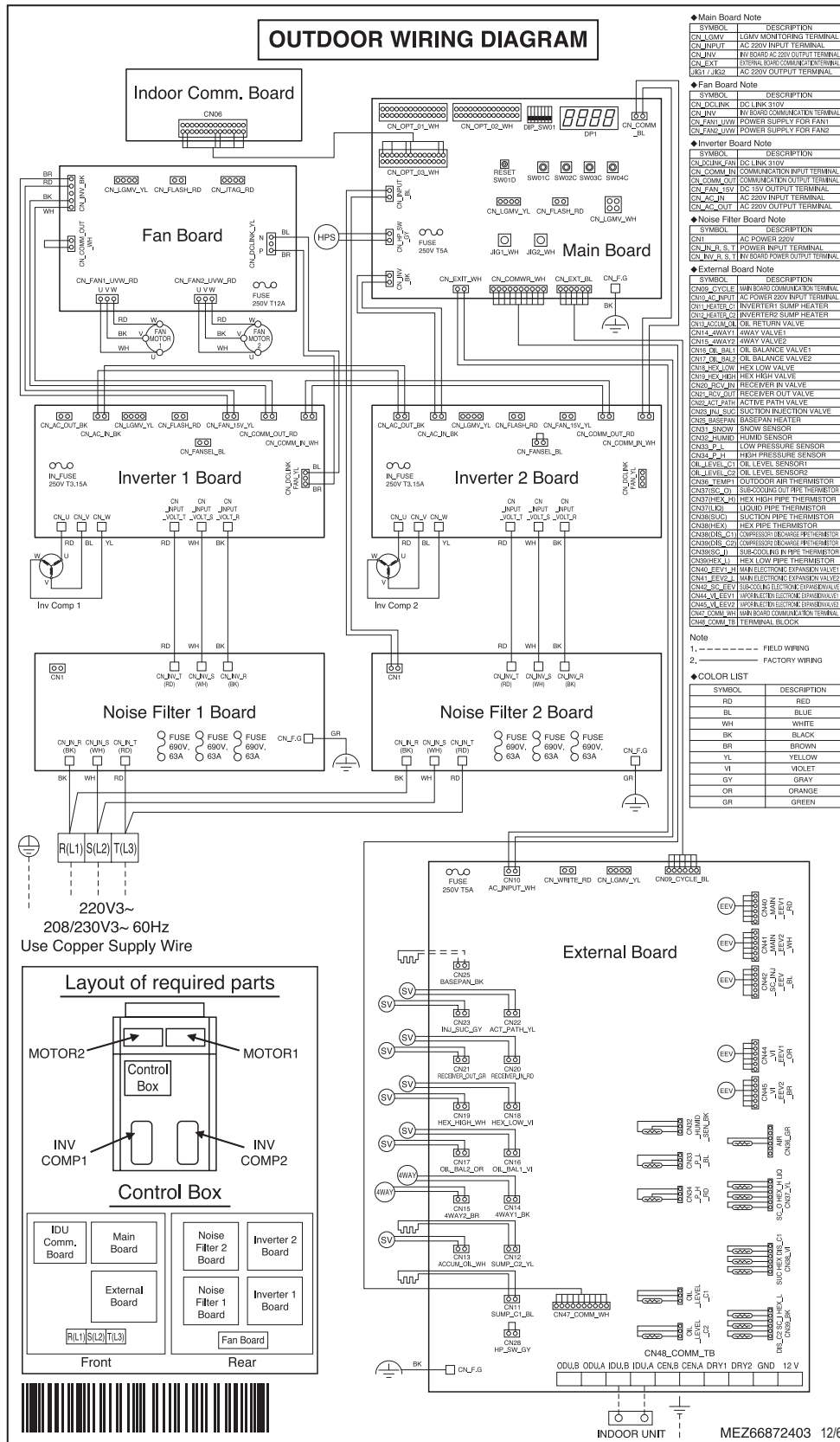

# WIRING DIAGRAMS



208-230V Outdoor Units

ARUM192BTE5 / ARUM216BTE5 / ARUM241BTE5

MULTI V 5 Outdoor Unit Service Manual

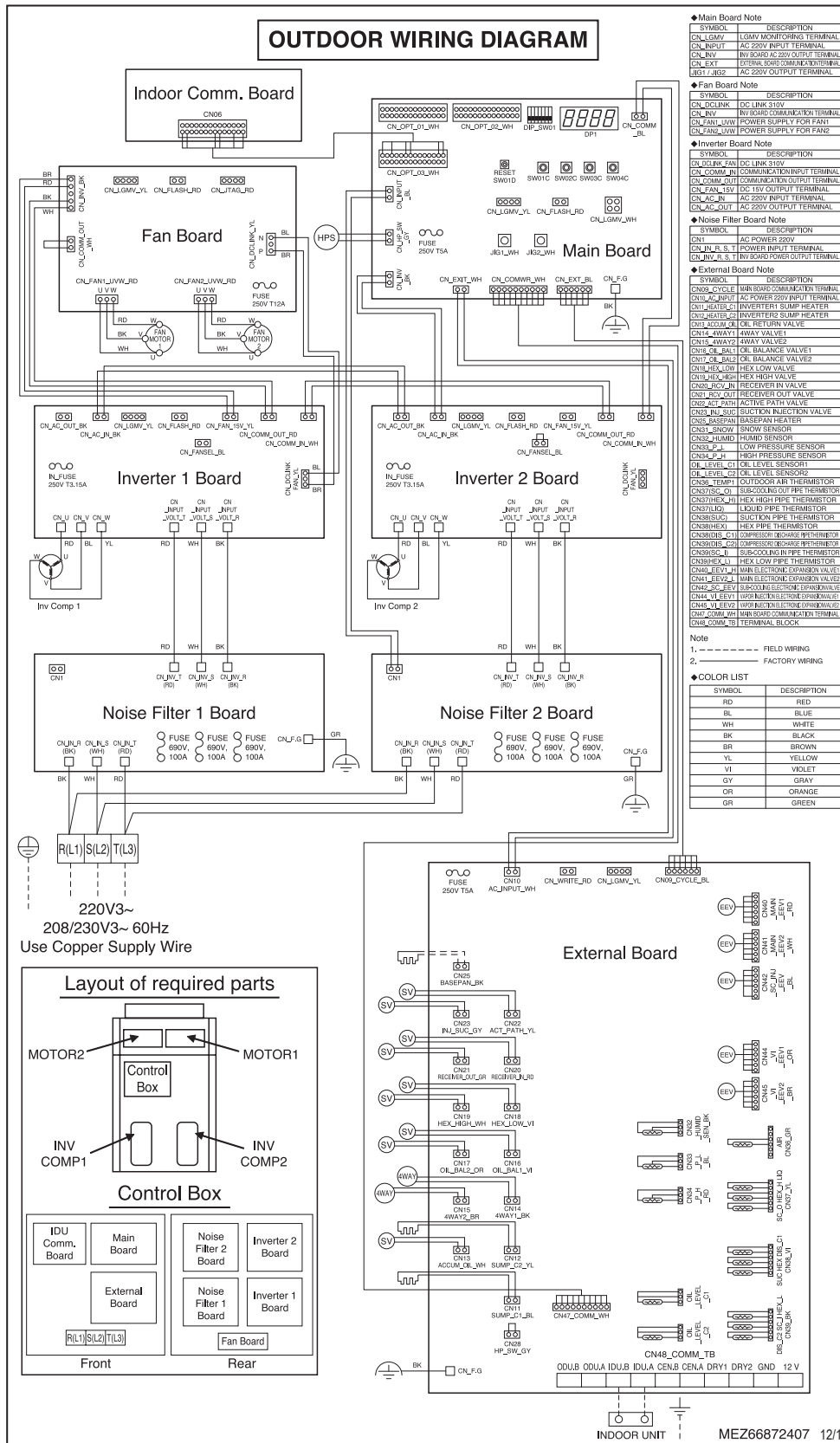

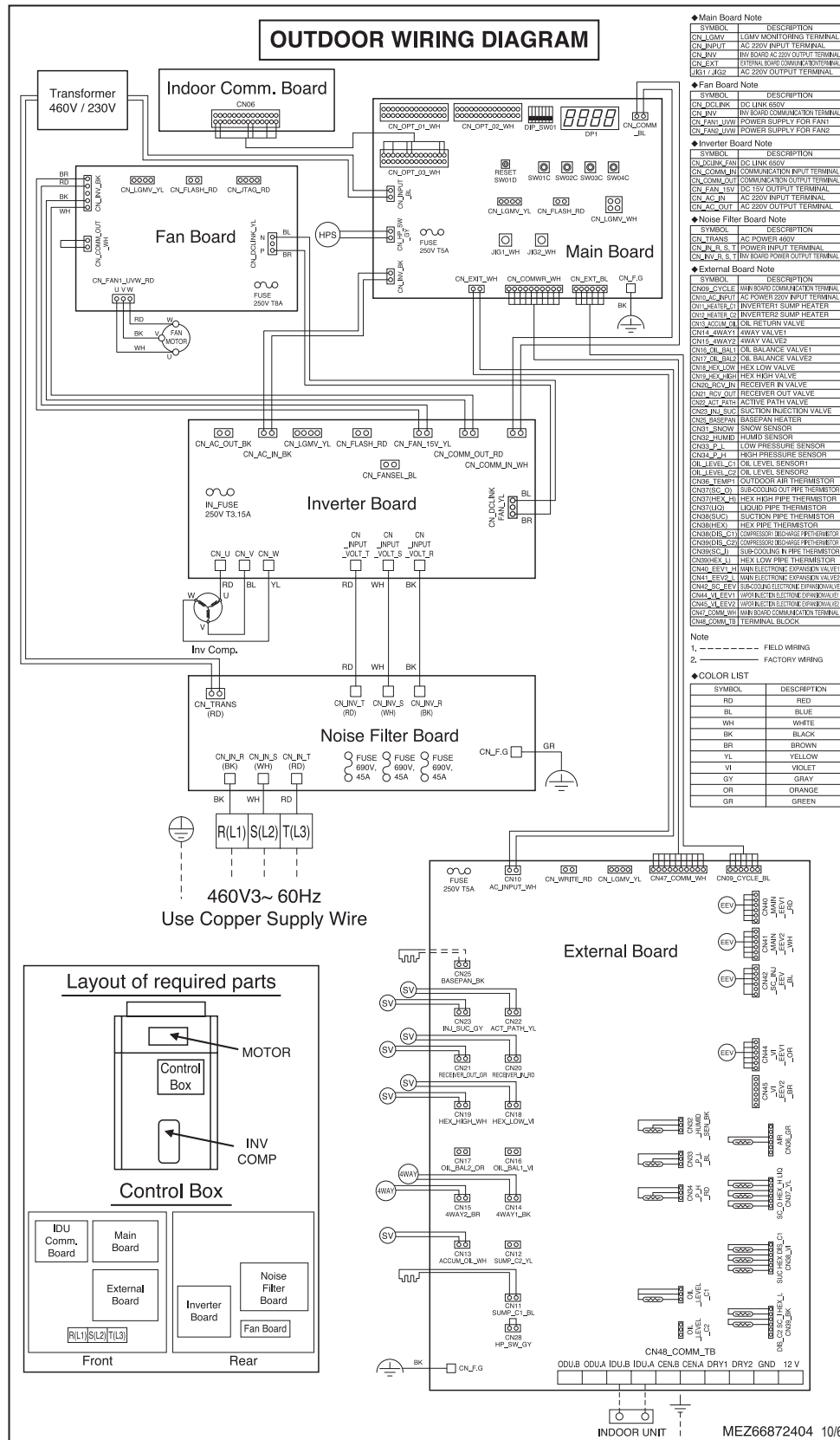

Outdoor Unit Functions

# WIRING DIAGRAMS

460V Outdoor Units

ARUM096DTE5 / ARUM121DTE5

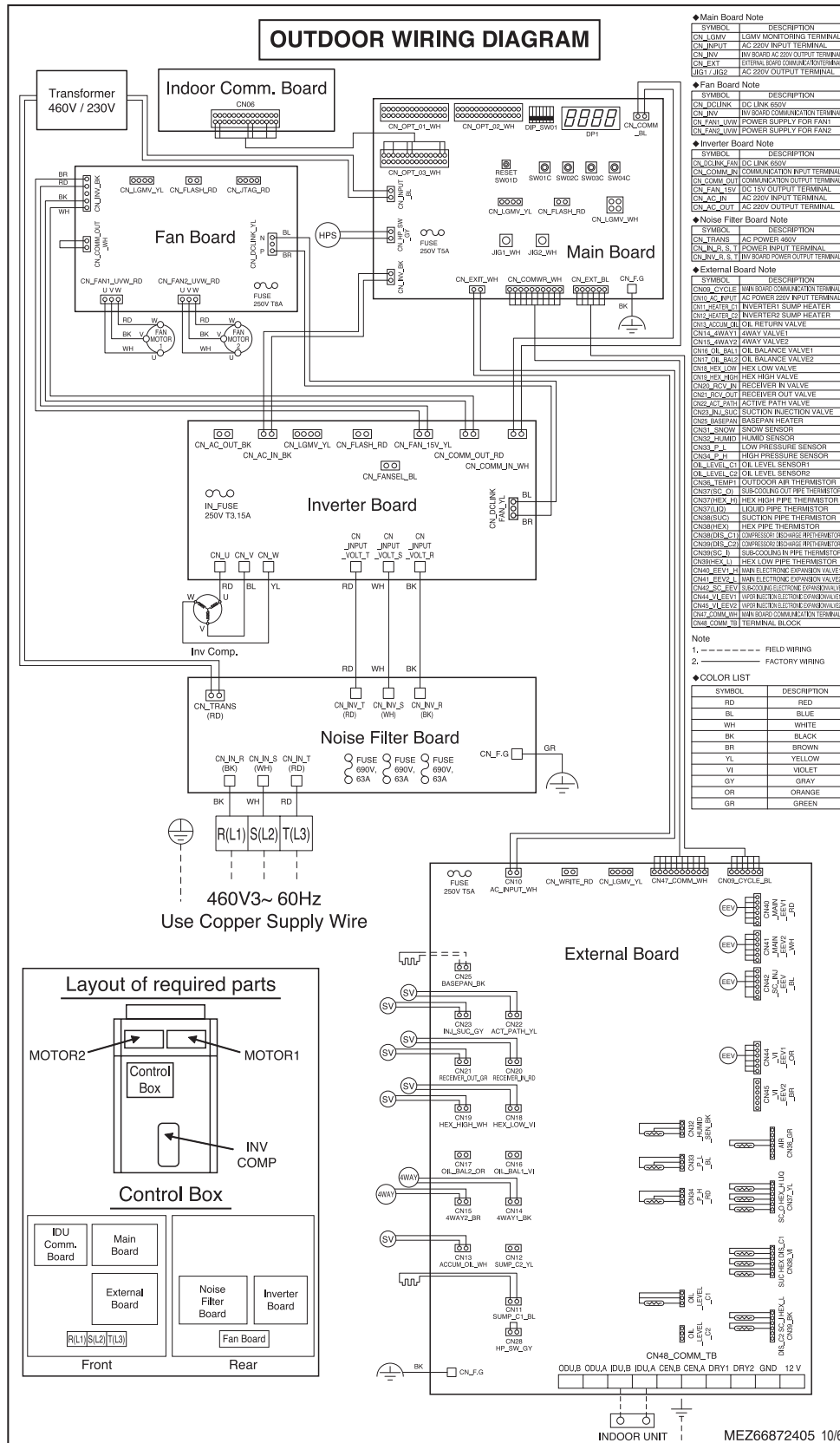

◆Main Board Note

SYMBOL	DESCRIPTION
CN_LINK	DC LINK WIRING TERMINAL
CN_INVT	AC 220V INPUT TERMINAL
CN_INV	INV BOARD AC 220V OUTPUT TERMINAL
CN_EXC	EXTERNAL BOARD POWER SUPPLY TERMINAL
JG1 / JG2	AC 220V OUTPUT TERMINAL

◆Fan Board Note

SYMBOL	DESCRIPTION
CN_LINK	DC LINK WIRING
CN_INV	INV BOARD COMMUNICATION INPUT TERMINAL
CN_COMM_IN	COMMUNICATION INPUT TERMINAL
CN_FAN_LOW	POWER SUPPLY FOR FAN
CN_FAN_HV	DC 15V OUTPUT TERMINAL
CN_AC_IN	AC 220V INPUT TERMINAL
CN_AC_OUT	AC 220V OUTPUT TERMINAL

◆Inverter Board Note

SYMBOL	DESCRIPTION
CN_LINK_FAN	DC LINK 650V
CN_COMM_IN	COMMUNICATION INPUT TERMINAL
CN_COMM_OUT	COMMUNICATION OUTPUT TERMINAL
CN_FAN_HV	DC 15V OUTPUT TERMINAL
CN_AC_IN	AC 220V INPUT TERMINAL
CN_AC_OUT	AC 220V OUTPUT TERMINAL

◆Noise Filter Board Note

SYMBOL	DESCRIPTION
CN_TRANS	AC POWER 460V
CN_EU_2_S_T	POWER INPUT TERMINAL
CN_EU_2_S_L	INVERTER POWER OUTPUT TERMINAL

◆External Board Note

SYMBOL	DESCRIPTION
CN29_CYCLE	MAIN BOARD COMMUNICATION TERMINAL
CN29_EU_2_S_T	AC POWER 220V INPUT TERMINAL
CN29_INVERTER_C1	INVERTER SUMP HEATER
CN29_INVERTER_C2	INVERTER SUMP HEATER
CN29_RETURN_VALVE	RETURN VALVE
CN29_4WAY1	4WAY VALVE1
CN29_4WAY2	4WAY VALVE2
CN29_OIL_BAL1	OIL BALANCE VALVE1
CN29_OIL_BAL2	OIL BALANCE VALVE2
CN29_HEX_LOH	HEX LOW VALVE
CN29_HEX_HOH	HEX HIGH VALVE
CN29_RECV_IN	RECEIVER IN VALVE
CN29_RECV_OUT	RECEIVER OUT VALVE
CN29_ACT_PATH	ACTIVE PATH VALVE
CN29_INJ_SUC	SUCTION INJECTION VALVE
CN29_BASEPAN	BASEPAN HEATER
CN29_SNOW	SNOW SENSOR
CN29_HUMID	HUMID SENSOR
CN29_P_L	LOW PRESSURE SENSOR
CN29_P_H	HIGH PRESSURE SENSOR
CN29_OIL_C1	OIL LEVEL SENSOR1
CN29_OIL_C2	OIL LEVEL SENSOR2
CN29_TEMP1	OUTDOOR AIR THERMISTOR
CN29_HEX_H	HEX HIGH PIPE THERMISTOR
CN29_HEX_L	HEX LOW PIPE THERMISTOR
CN29_SUCTION	SUCTION PIPE THERMISTOR
CN29_HEX_H	HEX PIPE THERMISTOR
CN29_C1	COMPRESSOR REGEAR THERMISTOR
CN29_C2	COMPRESSOR REGEAR THERMISTOR
CN29_S1	SUB-COOLING PIPE THERMISTOR
CN29_C1	HEX LOW PIPE THERMISTOR
CN29_EEV1	4WAY ELECTRONIC EXPANSION VALVE1
CN29_EEV2	4WAY ELECTRONIC EXPANSION VALVE2
CN29_EEV3	4WAY ELECTRONIC EXPANSION VALVE3
CN29_EEV4	4WAY ELECTRONIC EXPANSION VALVE4
CN29_COMM_IN	MAIN BOARD COMMUNICATION TERMINAL
CN29_COMM_IB	TERMINAL BLOCK

Note  
1. --- FIELD WIRING  
2. --- FACTORY WIRING

◆COLOR LIST

SYMBOL	DESCRIPTION
RD	RED
BL	BLUE
WH	WHITE
BK	BLACK
BR	BROWN
YL	YELLOW
VI	VIOLET
GY	GRAY
OR	ORANGE
GR	GREEN

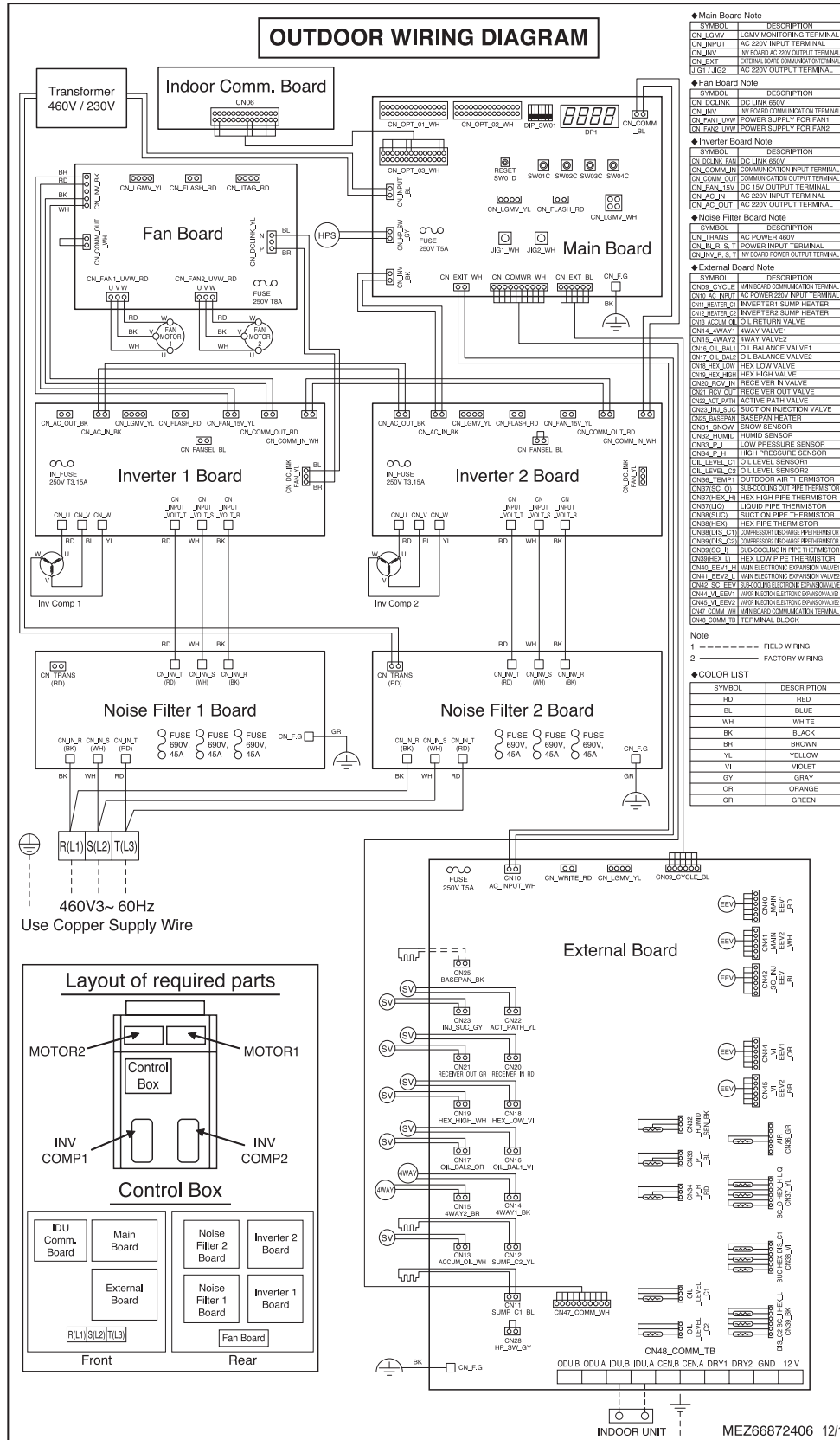

# WIRING DIAGRAMS



460V Outdoor Units

ARUM192DTE5 / ARUM216DTE5 / ARUM241DTE5

MULTI V 5 Outdoor Unit Service Manual

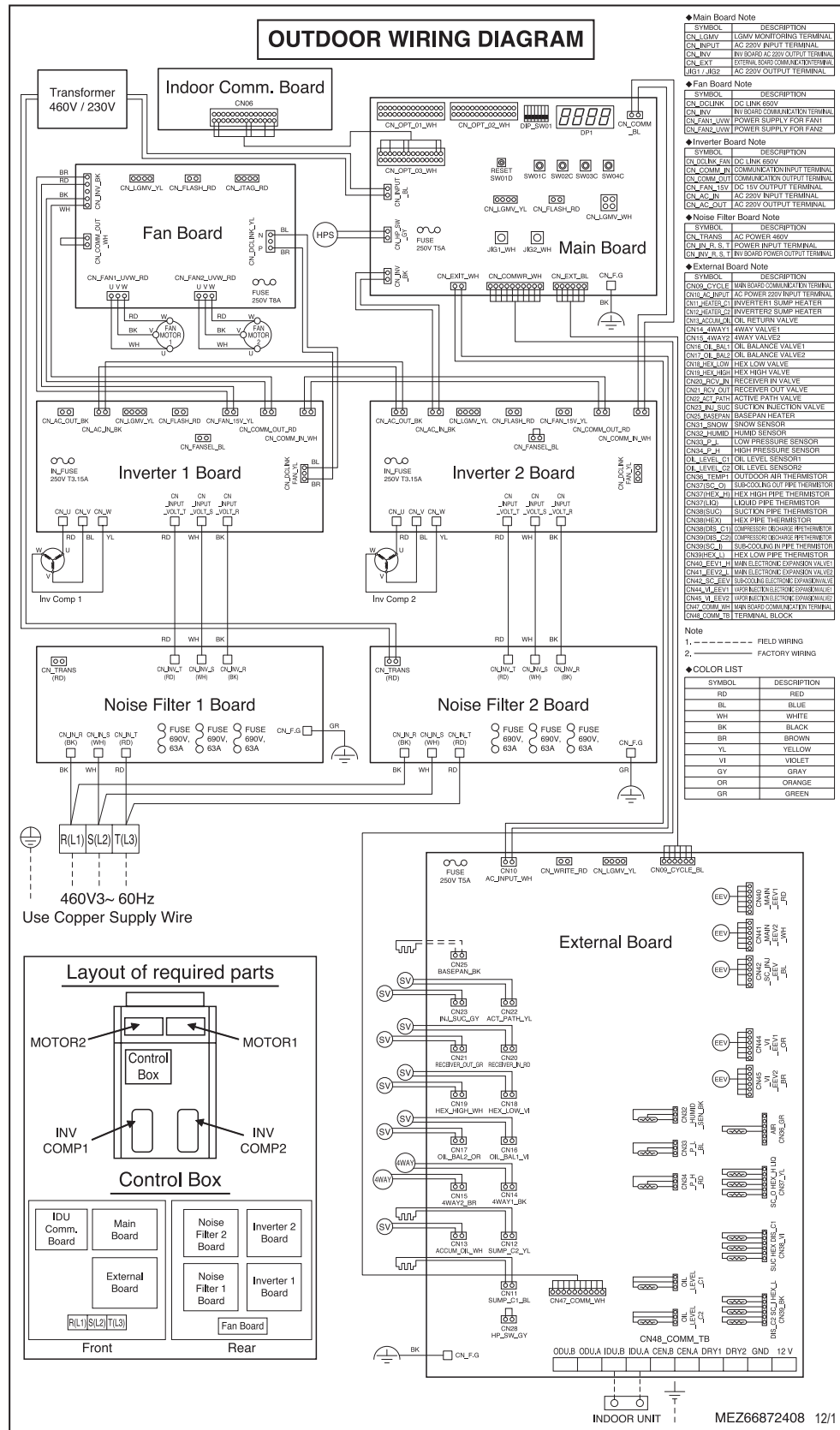

**Heat Pump – Cooling Mode**

- High Temperature High Pressure Vapor
- High Temperature High Pressure Liquid
- High Temperature High Pressure Liquid (Conditional)
- Low Temperature Low Pressure Vapor

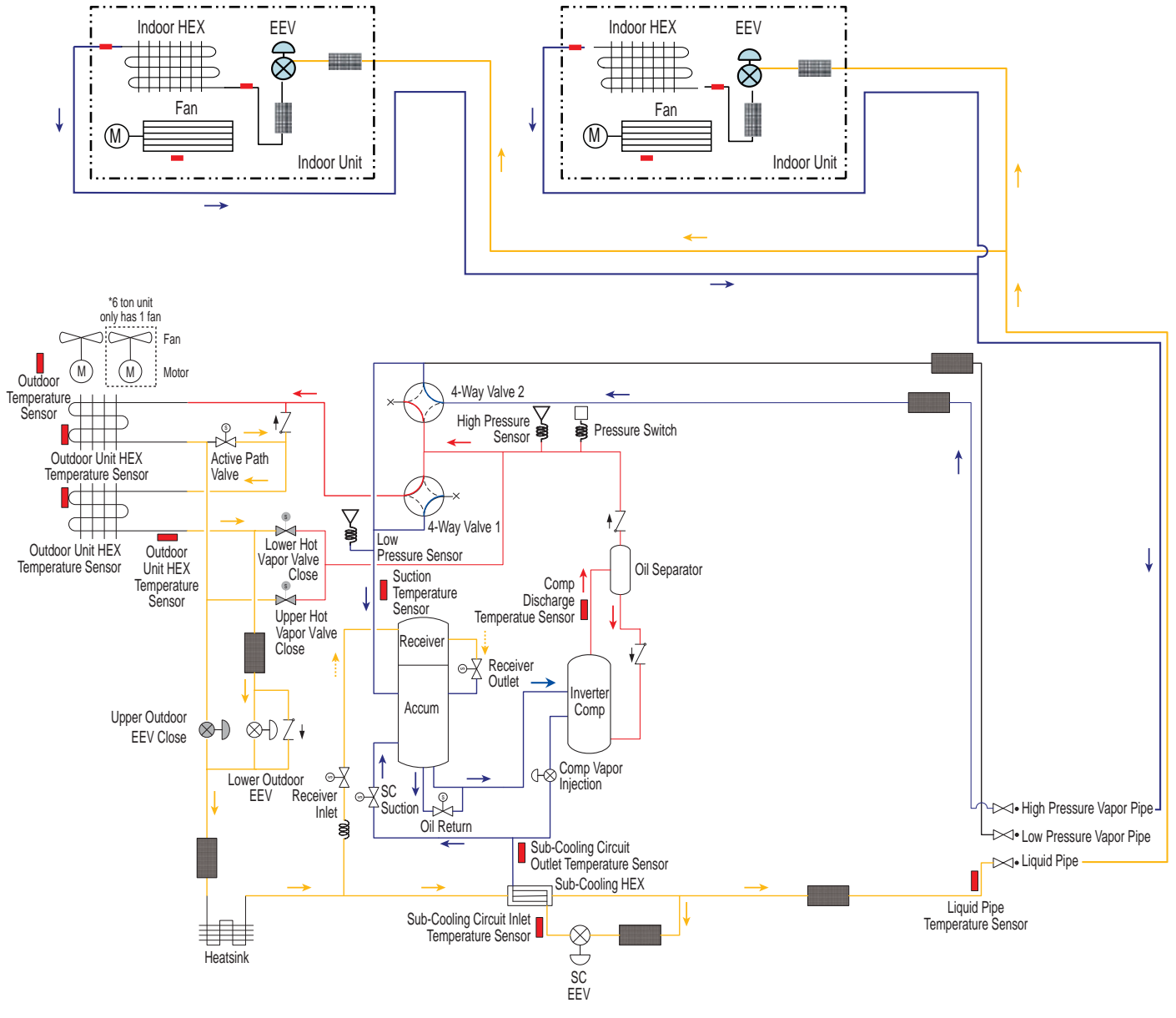

Outdoor Unit Functions

Remarks	Pressure Sensor	Temperature Sensor	Check Valve	Solenoid Valve
	Pressure Switch	SVC Valve	EEV	Strainer

# REFRIGERANT FLOW DIAGRAMS

**MULTI V 5**

ARUM072BTE5 / DTE5, ARUM096BTE5 / DTE5, ARUM121BTE5 / DTE5

Heat Pump Operation — Heating Mode

## Heat Pump – Heating Mode

- High Temperature High Pressure Vapor
- High Temperature High Pressure Liquid
- High Temperature High Pressure Liquid (Conditional)
- Low Temperature Low Pressure Vapor

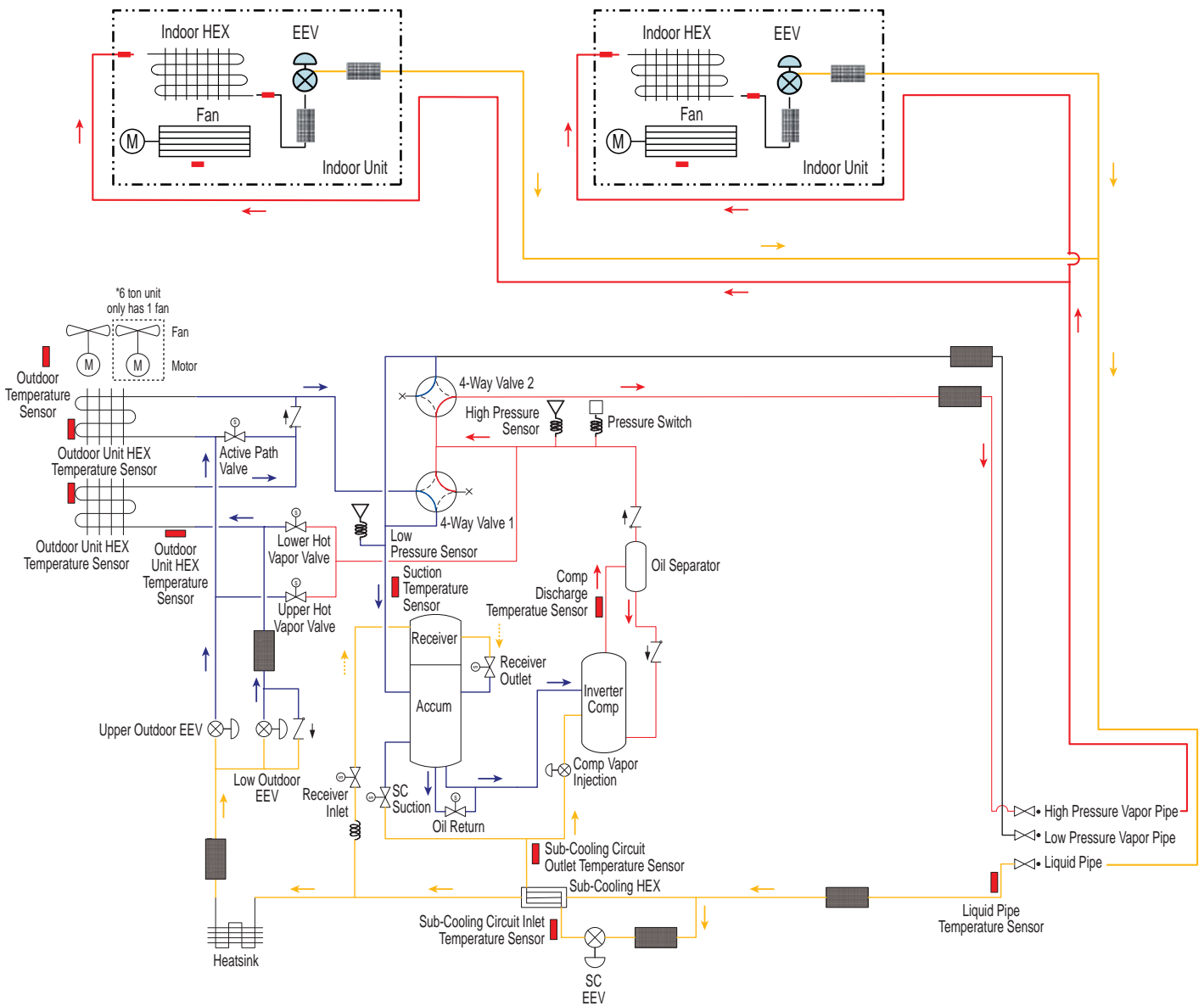

Remarks		Pressure Sensor		Temperature Sensor		Check Valve		Solenoid Valve
		Pressure Switch		SVC Valve		EEV		Strainer

MULTI V 5 Outdoor Unit Service Manual

#### Heat Pump – Oil Return and Defrost Operation

- High Temperature High Pressure Vapor
- High Temperature High Pressure Liquid
- High Temperature High Pressure Liquid (Conditional)
- Low Temperature Low Pressure Vapor

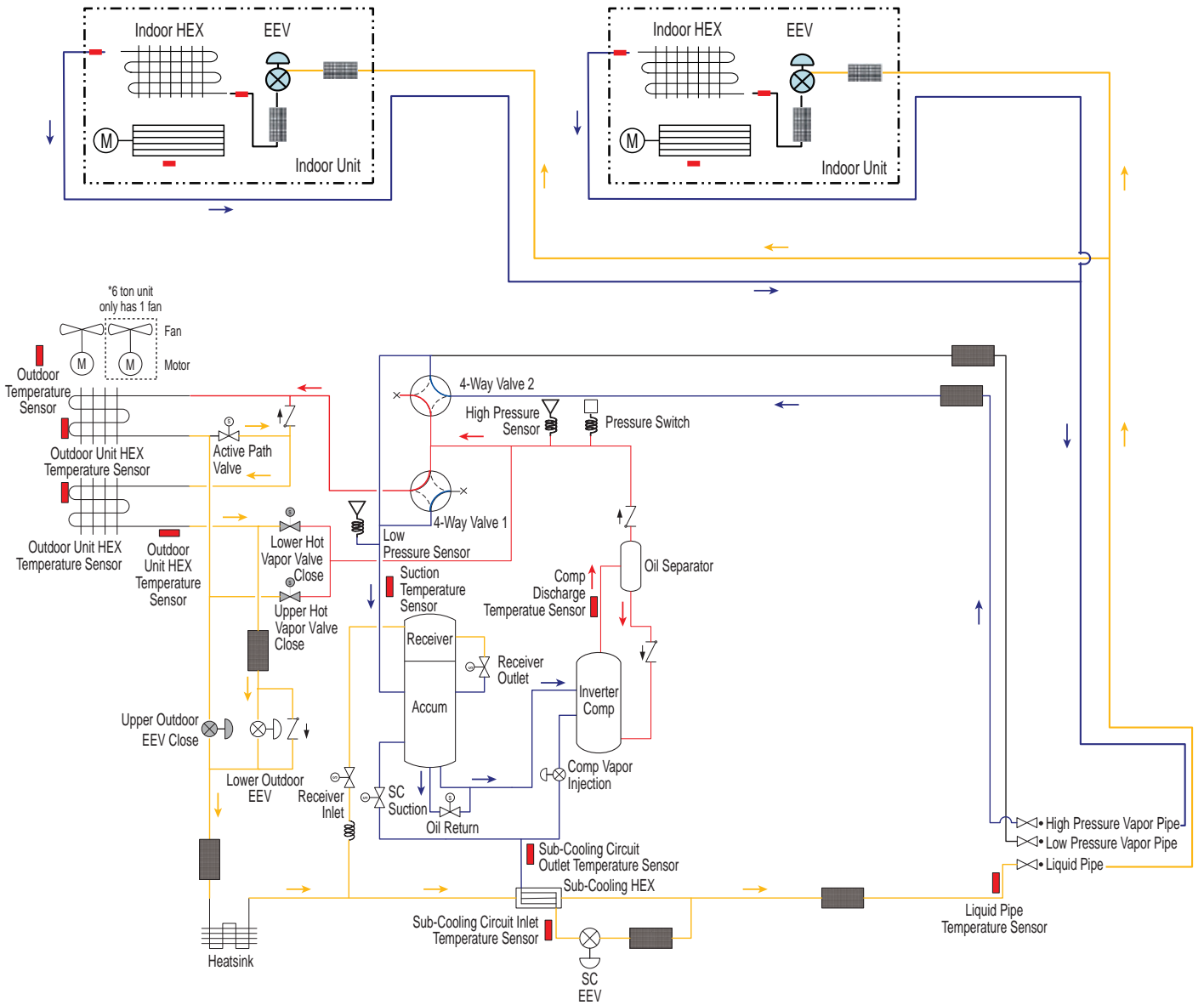

Remarks		Pressure Sensor		Temperature Sensor		Check Valve		Solenoid Valve
		Pressure Switch		SVC Valve		EEV		Strainer

# REFRIGERANT FLOW DIAGRAMS

**MULTI V 5**

ARUM072BTE5 / DTE5, ARUM096BTE5 / DTE5, ARUM121BTE5 / DTE5

Heat Pump Operation — Lower Heat Exchanger Defrost

## Heat Pump – Lower HEX Defrost Operation

- High Temperature High Pressure Vapor
- High Temperature High Pressure Liquid (Conditional)
- High Temperature High Pressure Liquid (Conditional)
- Low Temperature Low Pressure Vapor

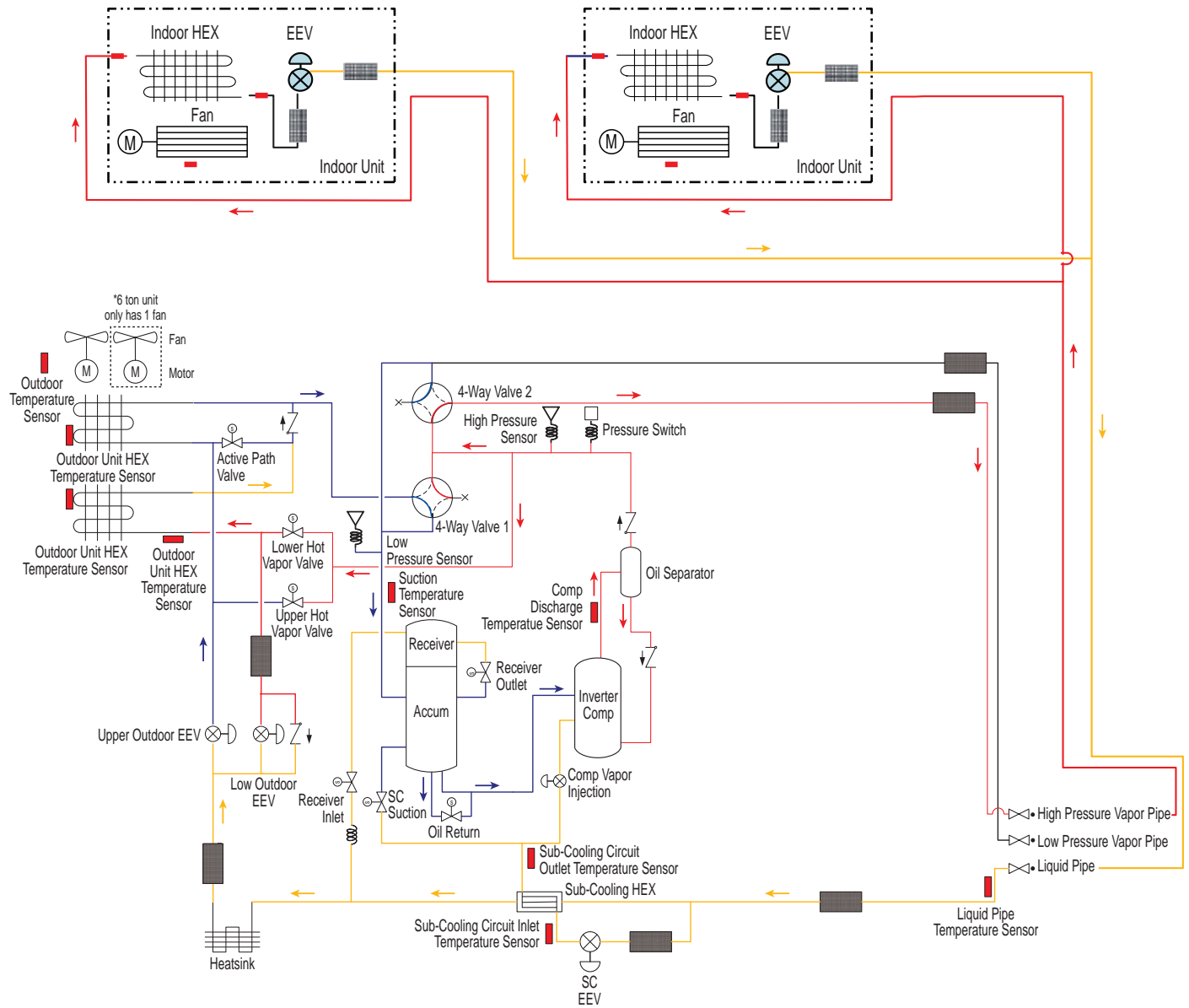

Remarks	Pressure Sensor	Temperature Sensor	Check Valve	Solenoid Valve
	Pressure Switch	SVC Valve	EEV	Strainer

MULTI V 5 Outdoor Unit Service Manual

**Heat Pump – Upper HEX Defrost Operation**

- ← High Temperature High Pressure Vapor
- High Temperature High Pressure Liquid
- High Temperature High Pressure Liquid (Conditional)
- ← Low Temperature Low Pressure Vapor

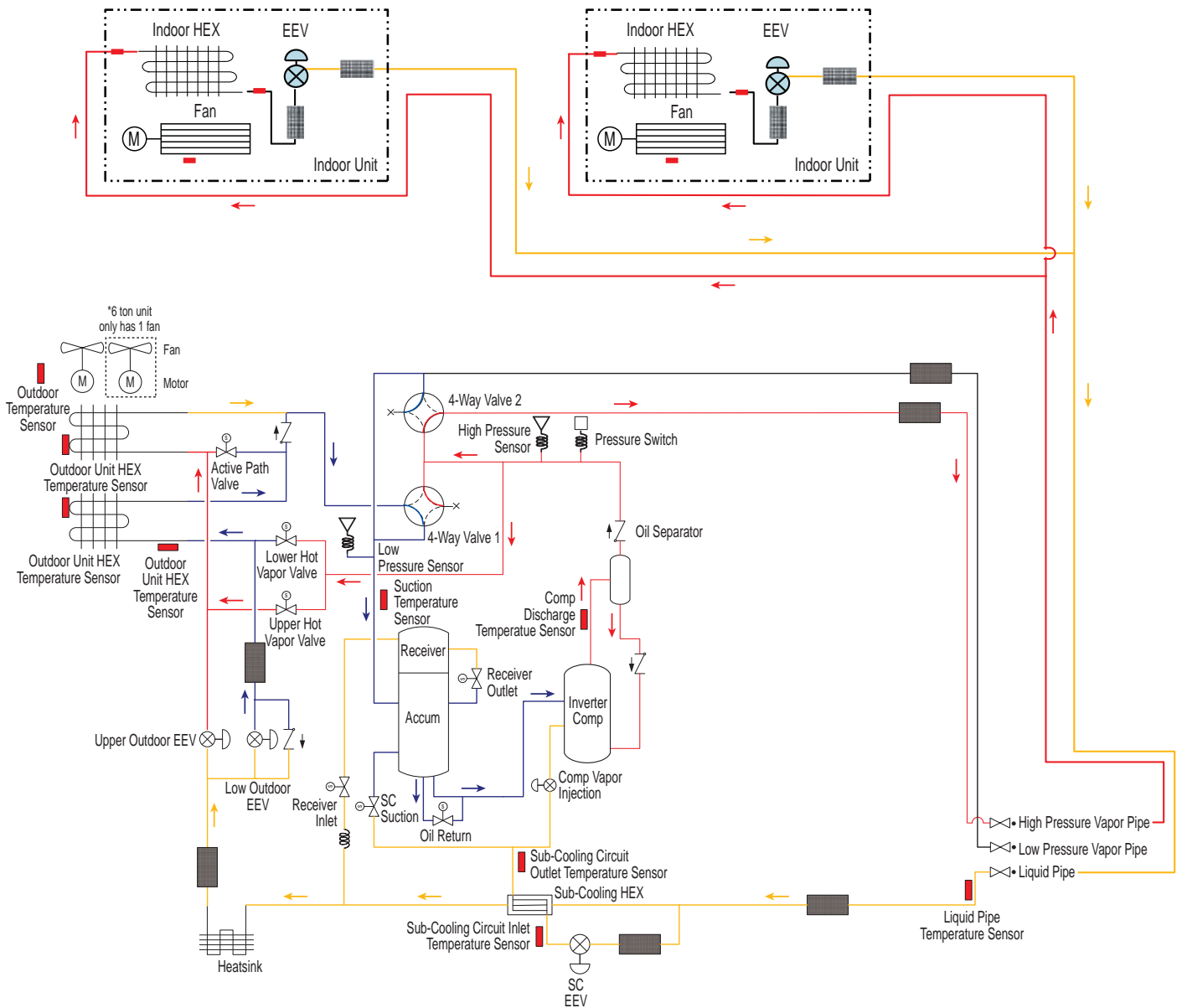

Outdoor Unit Functions

Remarks	Pressure Sensor	Temperature Sensor	Check Valve	Solenoid Valve
	Pressure Switch	SVC Valve	EEV	Strainer

# REFRIGERANT FLOW DIAGRAMS

**MULTI V 5**

ARUM144BTE5/DTE5, 168BTE5/DTE5, 192BTE5/DTE5, 216BTE5/DTE5, 241BTE5/DTE5  
Heat Pump Operation — Cooling Mode

## Heat Pump – Cooling Mode

- High Temperature High Pressure Vapor
- High Temperature High Pressure Liquid
- High Temperature High Pressure Liquid (Conditional)
- Low Temperature Low Pressure Vapor

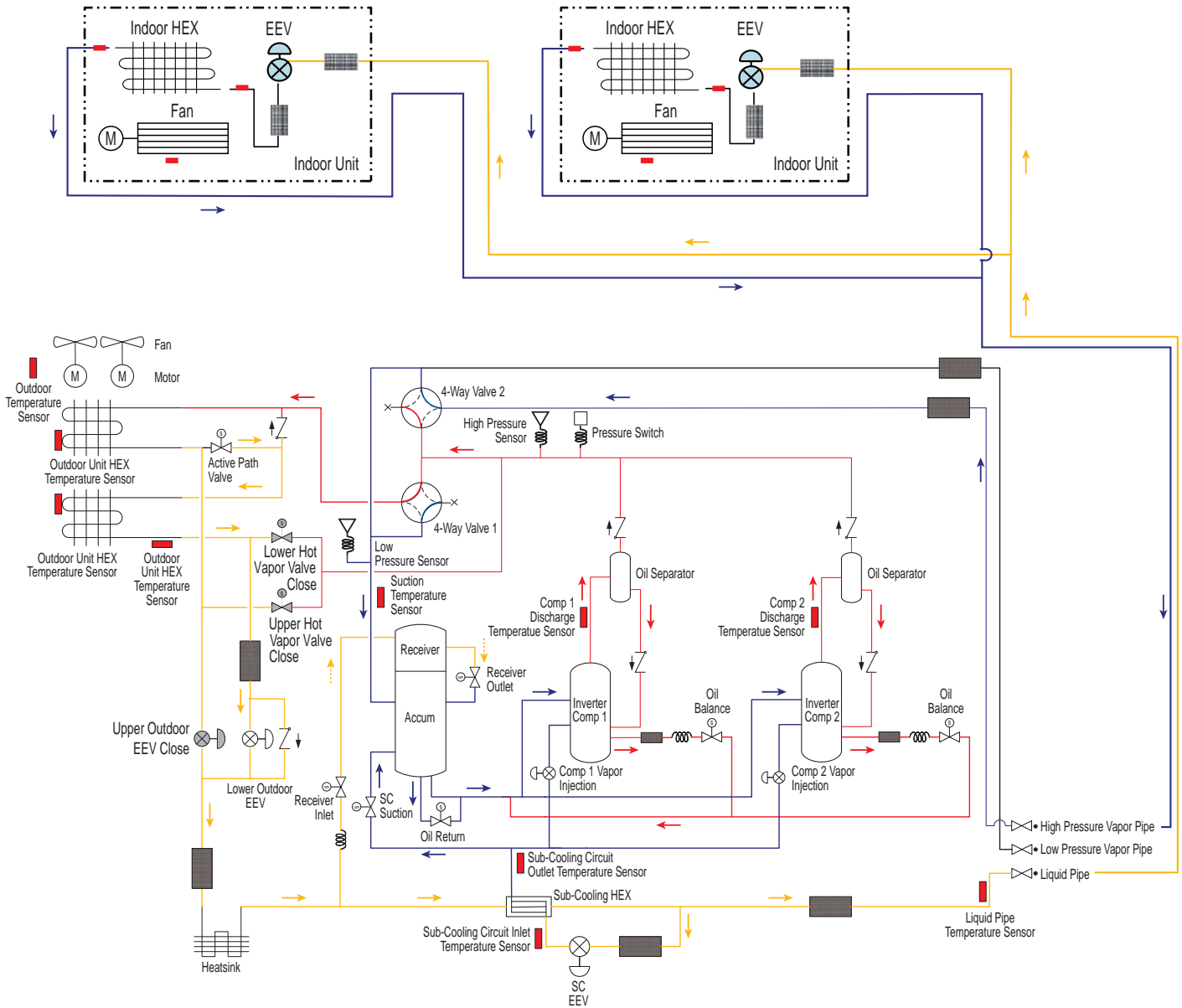

Remarks	Pressure Sensor	Temperature Sensor	Check Valve	Solenoid Valve
	Pressure Switch	SVC Valve	EEV	Strainer

MULTI V 5 Outdoor Unit Service Manual

**Heat Pump – Heating Mode**

- ← High Temperature High Pressure Vapor
- High Temperature High Pressure Liquid
- High Temperature High Pressure Liquid (Conditional)
- ← Low Temperature Low Pressure Vapor

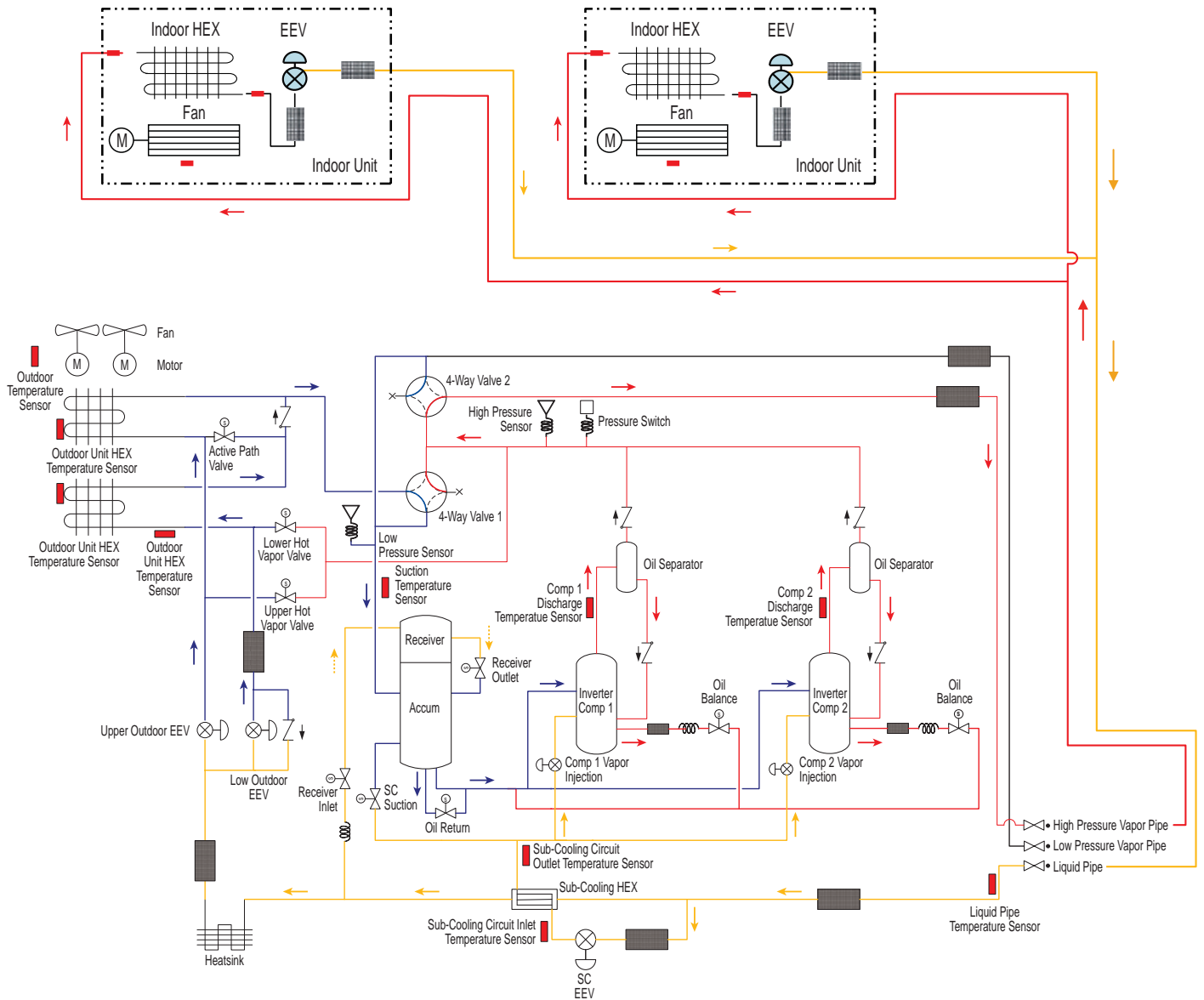

Outdoor Unit Functions

Remarks	Pressure Sensor	Temperature Sensor	Check Valve	Solenoid Valve
	Pressure Switch	SVC Valve	EEV	Strainer

# REFRIGERANT FLOW DIAGRAMS

**MULTI V 5**

ARUM144BTE5/DTE5, 168BTE5/DTE5, 192BTE5/DTE5, 216BTE5/DTE5, 241BTE5/DTE5  
Heat Pump Operation — Oil Return and Defrost

## Heat Pump – Oil Return and Defrost Operation

- High Temperature High Pressure Vapor
- High Temperature High Pressure Liquid
- High Temperature High Pressure Liquid (Conditional)
- Low Temperature Low Pressure Vapor

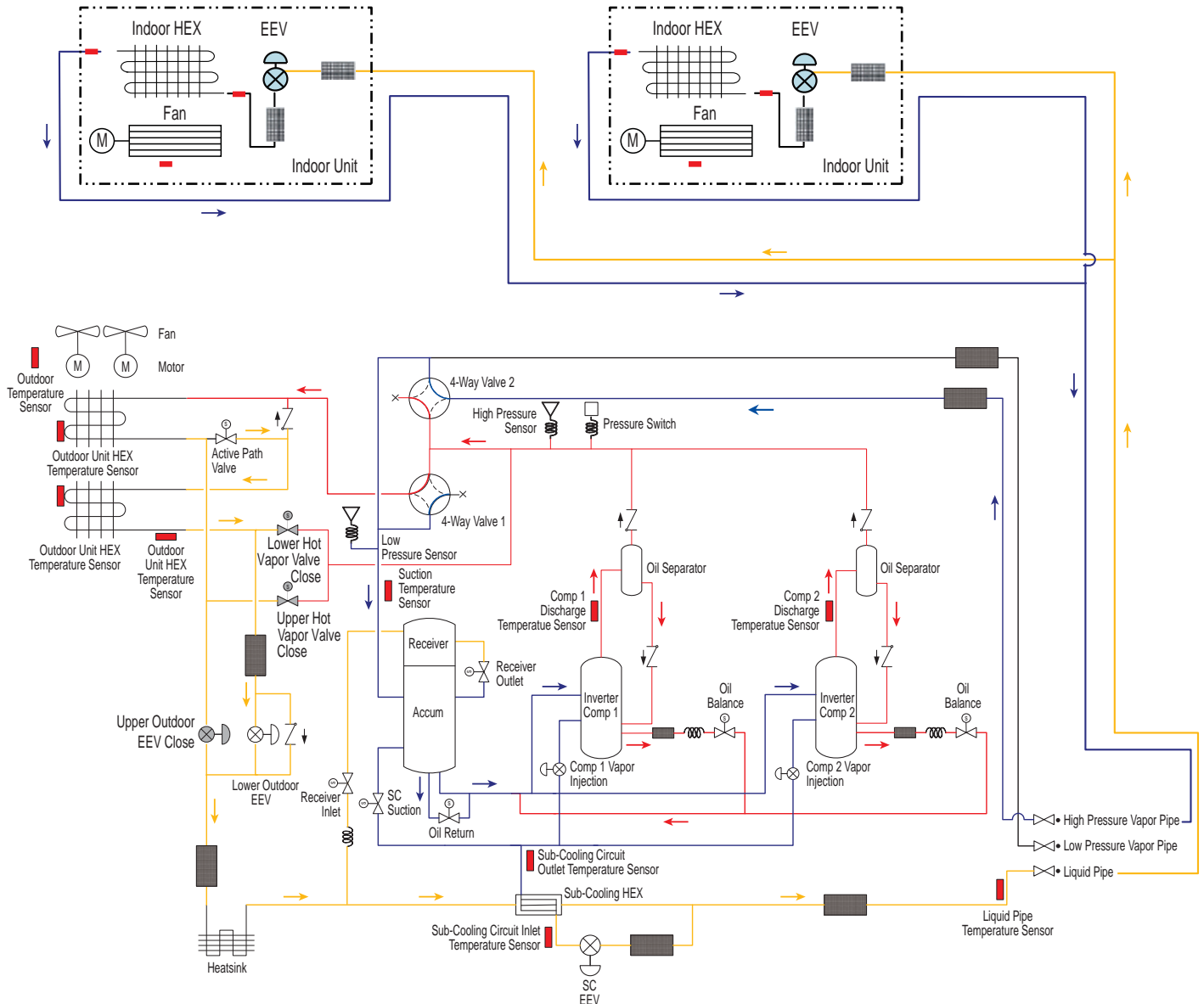

Remarks		Pressure Sensor		Temperature Sensor		Check Valve		Solenoid Valve
		Pressure Switch		SVC Valve		EEV		Strainer

MULTI V 5 Outdoor Unit Service Manual

**Heat Pump – Lower HEX Defrost Operation**

- ← High Temperature High Pressure Vapor
- ← High Temperature High Pressure Liquid
- ← High Temperature High Pressure Liquid (Conditional)
- ← Low Temperature Low Pressure Vapor

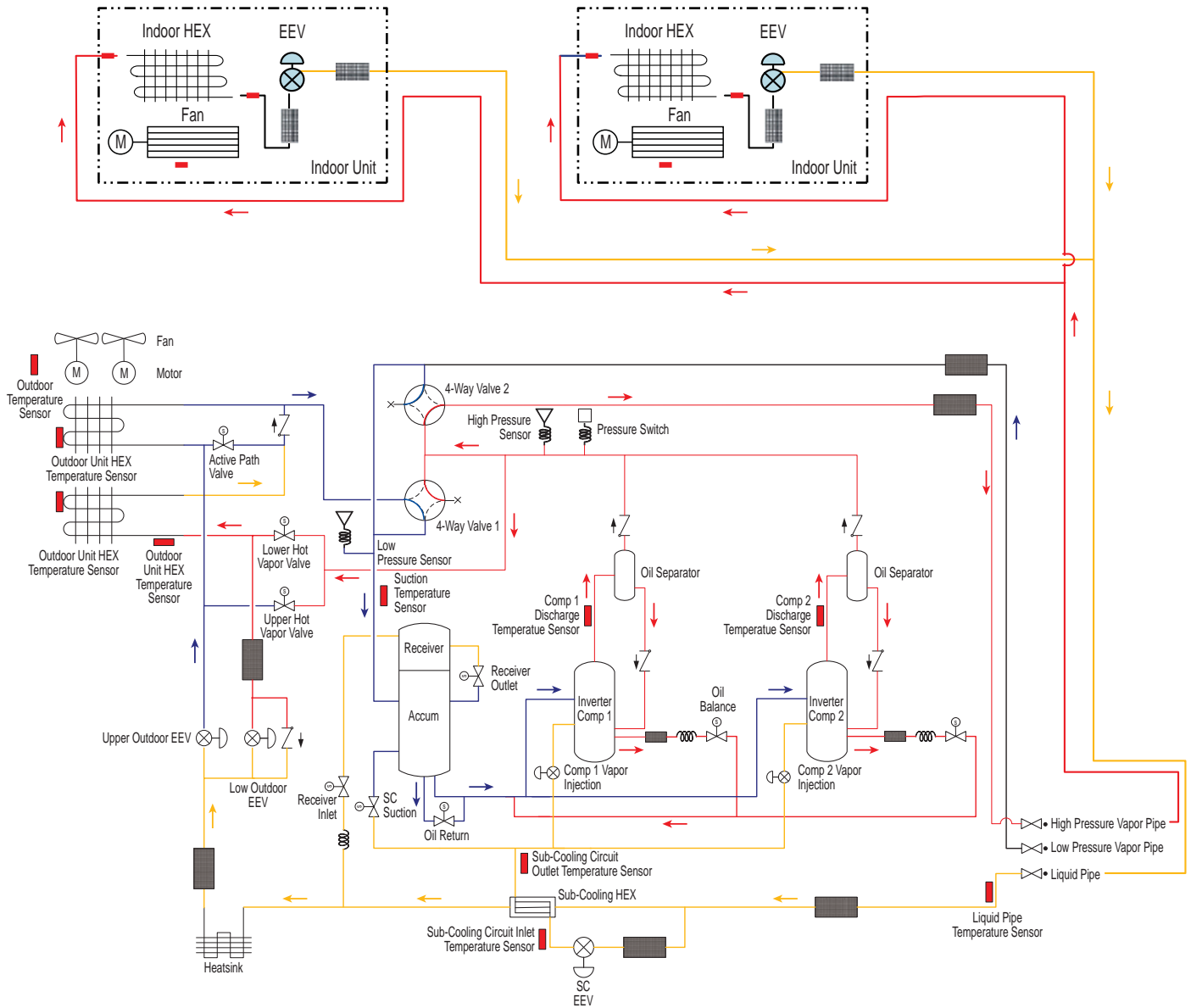

Outdoor Unit Functions

Remarks		Pressure Sensor		Temperature Sensor		Check Valve		Solenoid Valve
		Pressure Switch		SVC Valve		EEV		Strainer

# REFRIGERANT FLOW DIAGRAMS

**MULTI V 5**

ARUM144BTE5/DTE5, 168BTE5/DTE5, 192BTE5/DTE5, 216BTE5/DTE5, 241BTE5/DTE5  
Heat Pump Operation — Upper Heat Exchanger Defrost

## Heat Pump – Upper HEX Defrost Operation

- ← High Temperature High Pressure Vapor
- High Temperature High Pressure Liquid
- High Temperature High Pressure Liquid (Conditional)
- ← Low Temperature Low Pressure Vapor

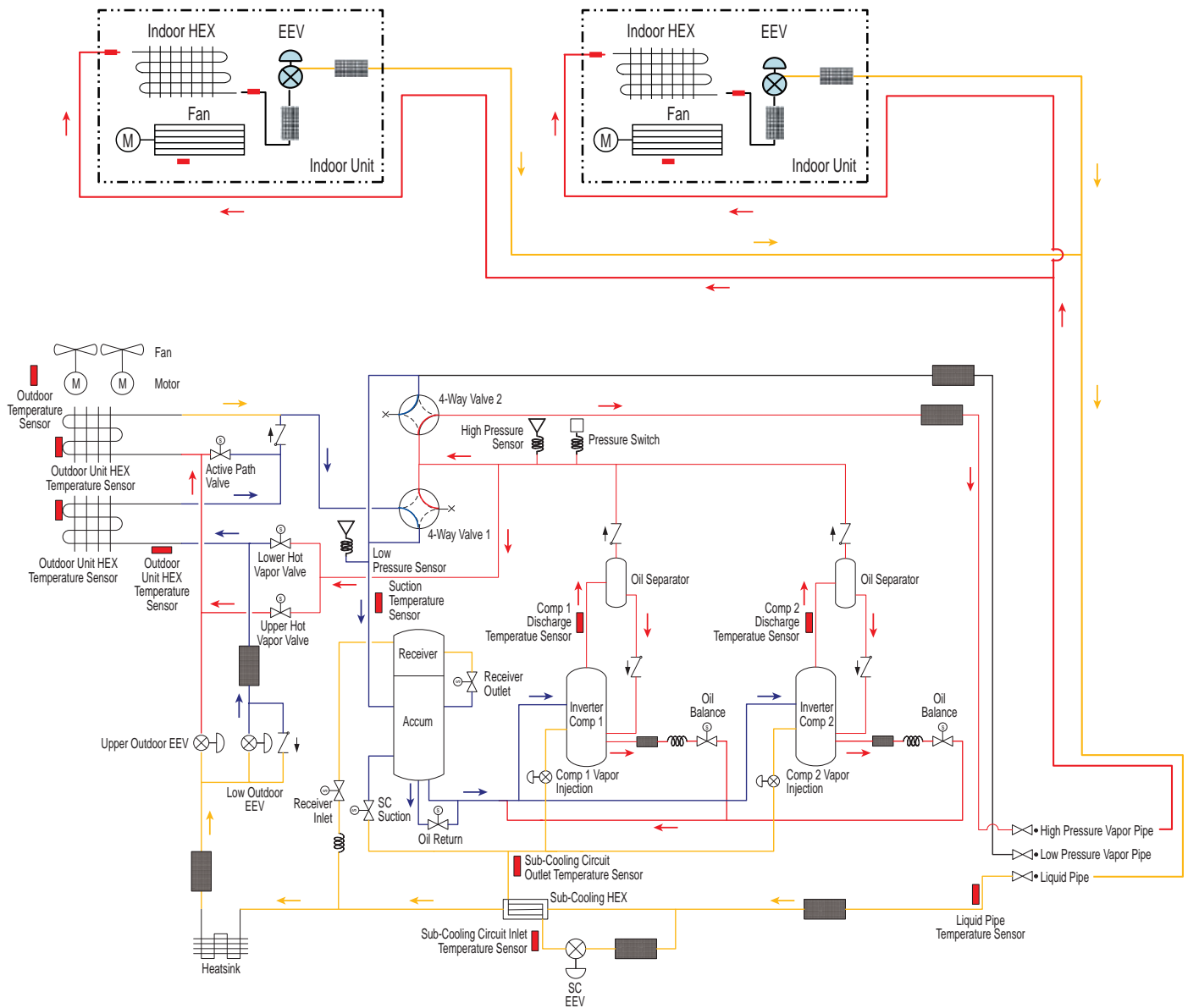

Remarks		Pressure Sensor		Temperature Sensor		Check Valve		Solenoid Valve
		Pressure Switch		SVC Valve		EEV		Strainer

MULTI V 5 Outdoor Unit Service Manual

**Heat Recovery – Cooling Mode**

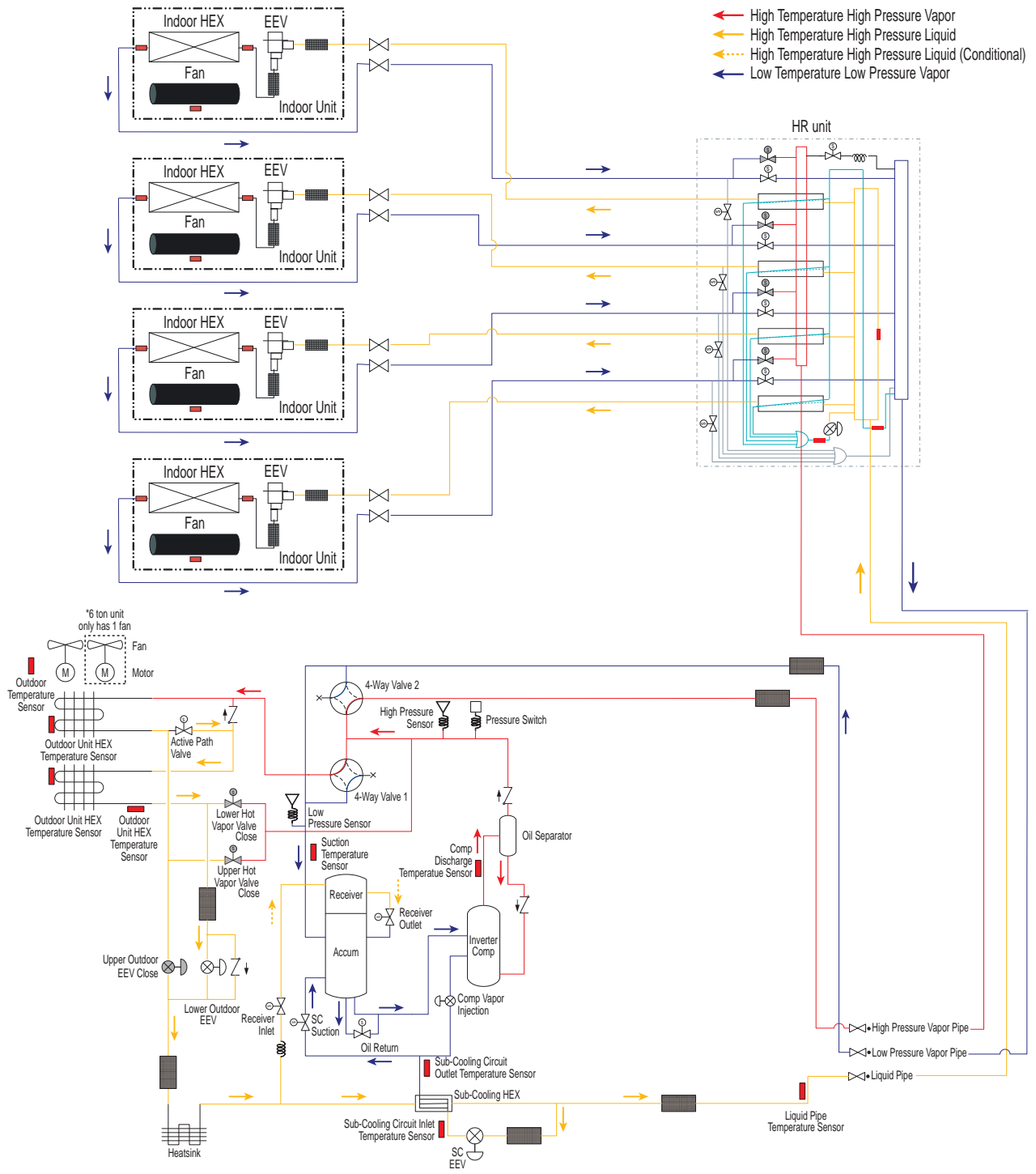

Outdoor Unit Functions

Remarks		Pressure Sensor		Temperature Sensor		Check Valve		Solenoid Valve
		Pressure Switch		SVC Valve		EEV		Strainer

# REFRIGERANT FLOW DIAGRAMS

**MULTI V 5**

ARUM072BTE5 / DTE5, ARUM096BTE5 / DTE5, ARUM121BTE5 / DTE5

Heat Recovery Operation — Heating Mode

## Heat Recovery – Heating Mode

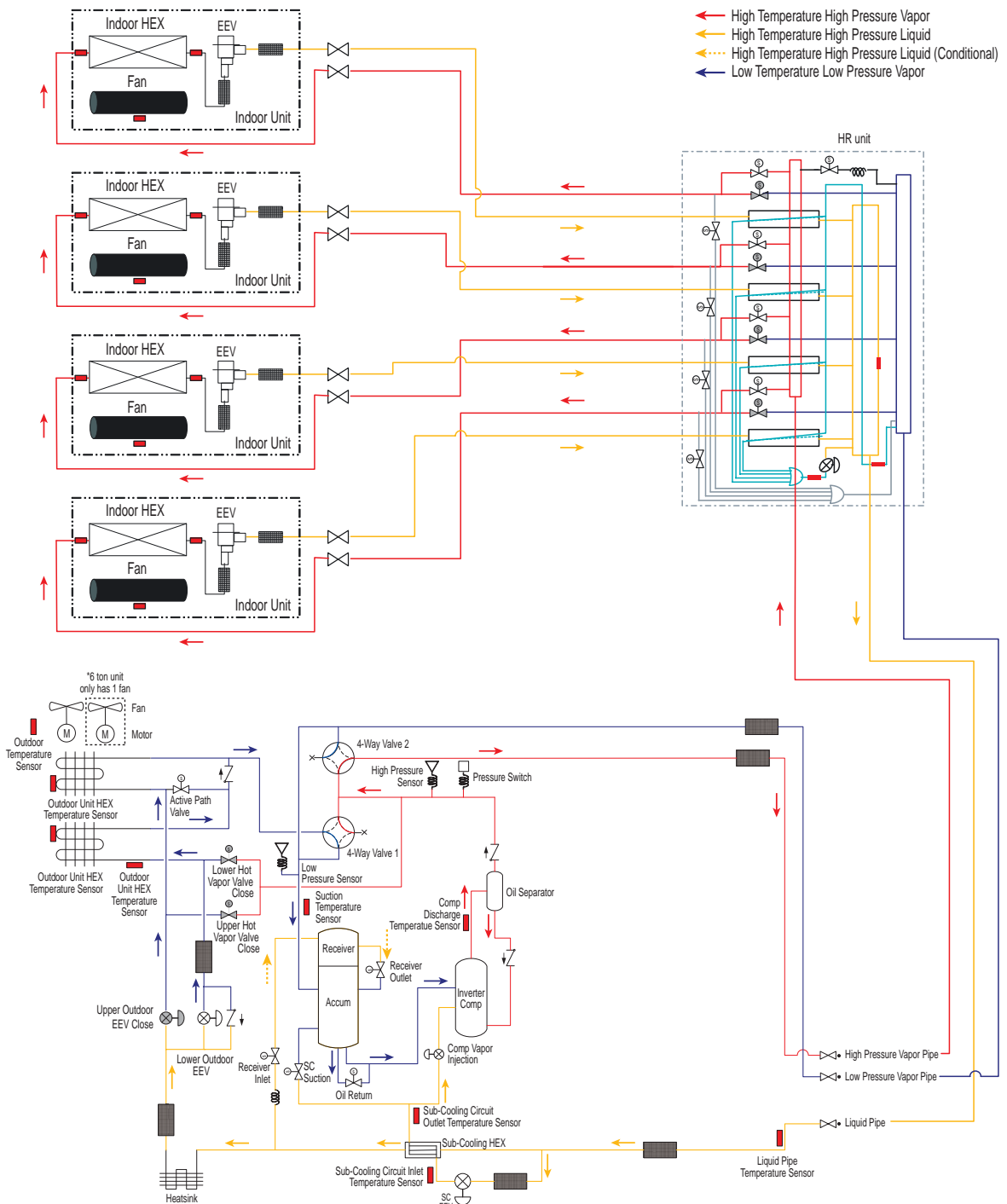

Remarks	Pressure Sensor	Temperature Sensor	Check Valve	Solenoid Valve
	Pressure Switch	SVC Valve	EEV	Strainer

**Heat Recovery – Cooling-Based Simultaneous Operation**

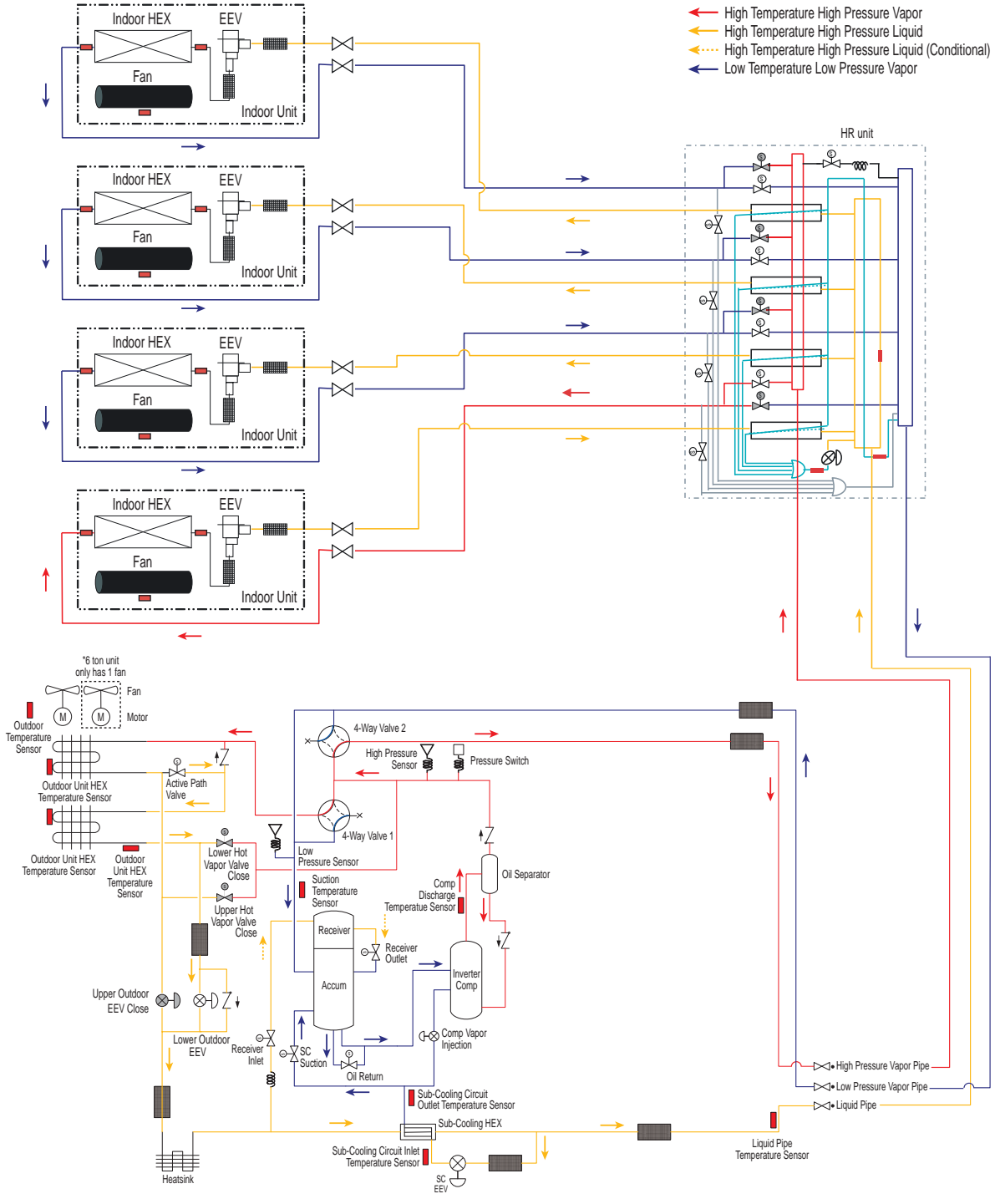

Outdoor Unit Functions

Remarks	Pressure Sensor	Temperature Sensor	Check Valve	Solenoid Valve
	Pressure Switch	SVC Valve	EEV	Strainer

# REFRIGERANT FLOW DIAGRAMS

**MULTI V 5**

ARUM072BTE5 / DTE5, ARUM096BTE5 / DTE5, ARUM121BTE5 / DTE5

Heat Recovery Operation — Heating-Based Simultaneous Mode

## Heat Recovery – Heating-Based Simultaneous Operation

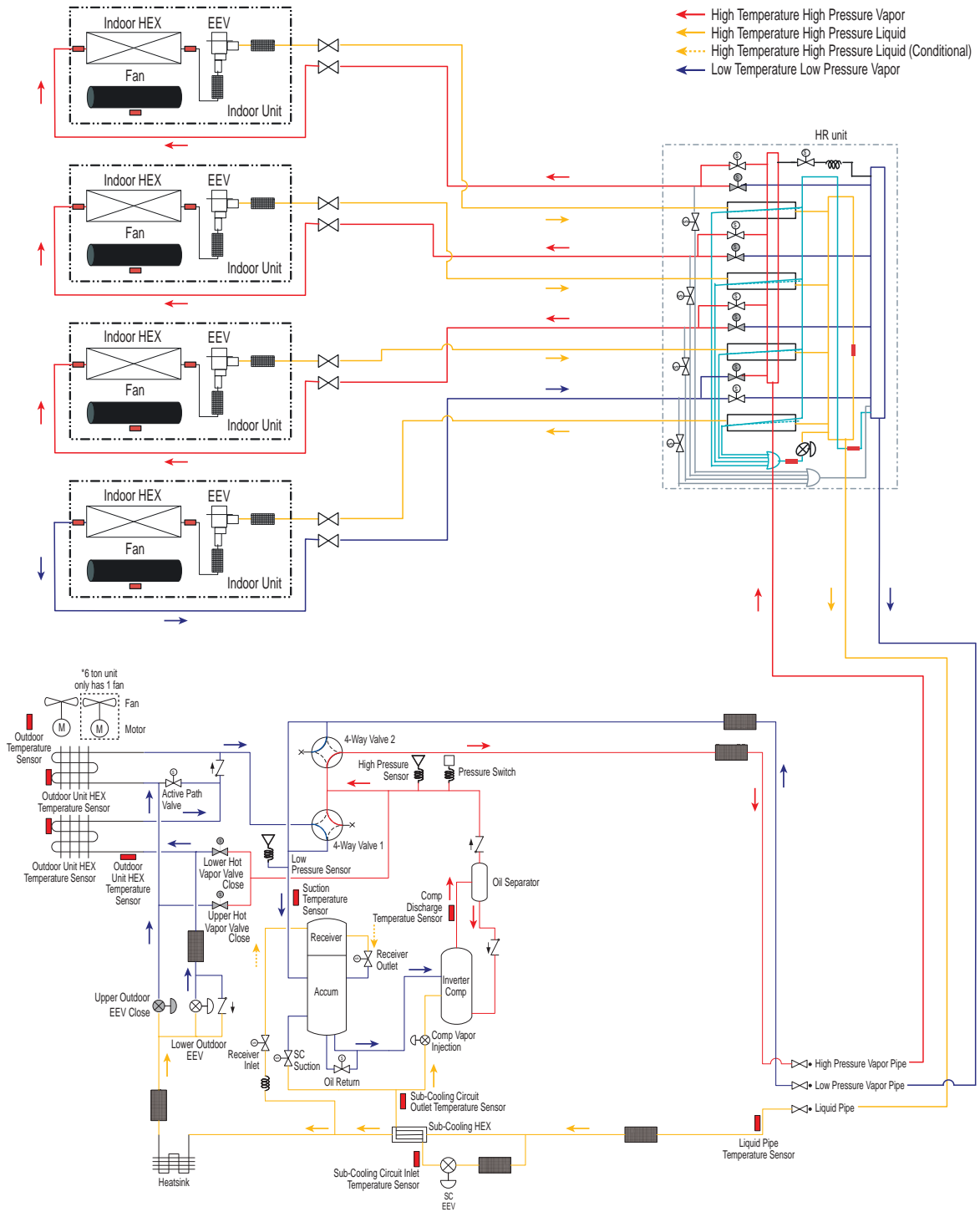

Remarks	Pressure Sensor	Temperature Sensor	Check Valve	Solenoid Valve
	Pressure Switch	SVC Valve	EEV	Strainer

MULTI V 5 Outdoor Unit Service Manual

**Heat Recovery – Balanced Simultaneous Operation**

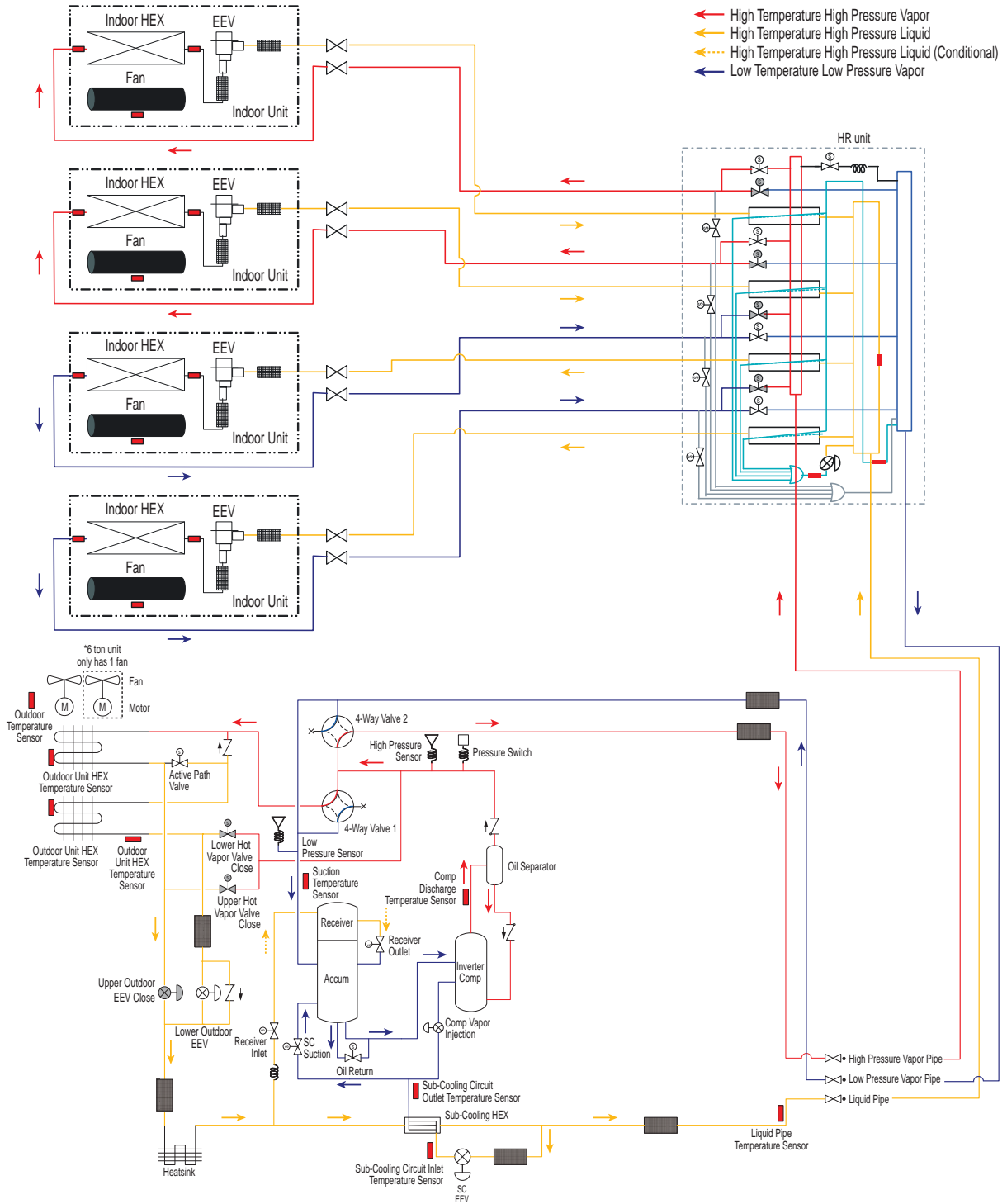

Outdoor Unit Functions

Remarks		Pressure Sensor		Temperature Sensor		Check Valve		Solenoid Valve
		Pressure Switch		SVC Valve		EEV		Strainer

# REFRIGERANT FLOW DIAGRAMS

**MULTI V 5**

ARUM072BTE5 / DTE5, ARUM096BTE5 / DTE5, ARUM121BTE5 / DTE5

Heat Recovery Operation — Oil Return and Defrost

## Heat Recovery – Oil Return and Defrost Operation

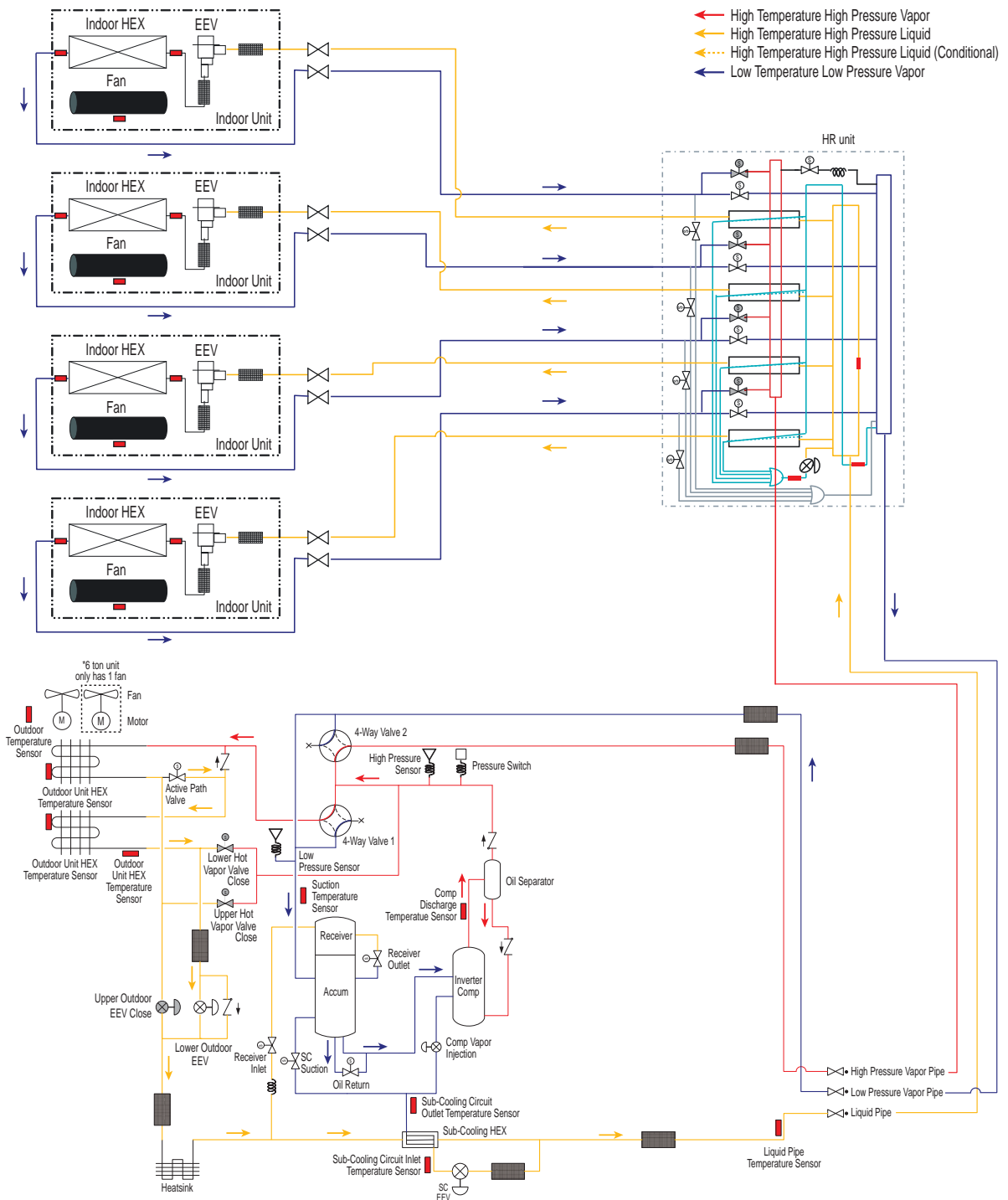

Remarks	Pressure Sensor	Temperature Sensor	Check Valve	Solenoid Valve
	Pressure Switch	SVC Valve	EEV	Strainer

MULTI V 5 Outdoor Unit Service Manual

**Heat Recovery – Lower HEX Defrost Operation**

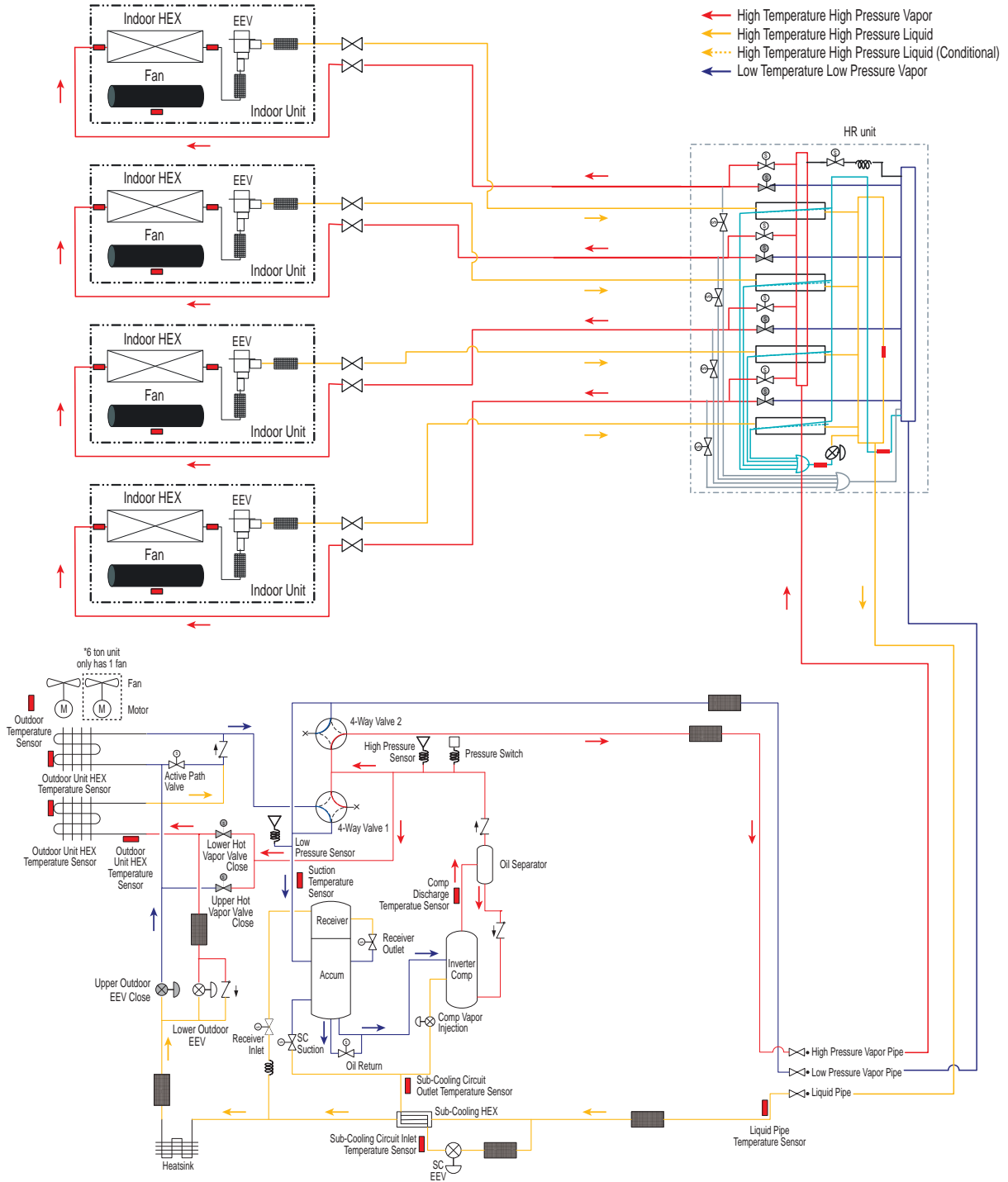

Outdoor Unit Functions

Remarks		Pressure Sensor		Temperature Sensor		Check Valve		Solenoid Valve
		Pressure Switch		SVC Valve		EEV		Strainer

# REFRIGERANT FLOW DIAGRAMS

**MULTI V 5**

ARUM072BTE5 / DTE5, ARUM096BTE5 / DTE5, ARUM121BTE5 / DTE5

Heat Recovery Operation — Upper Heat Exchanger Defrost

## Heat Recovery – Upper HEX Defrost Operation

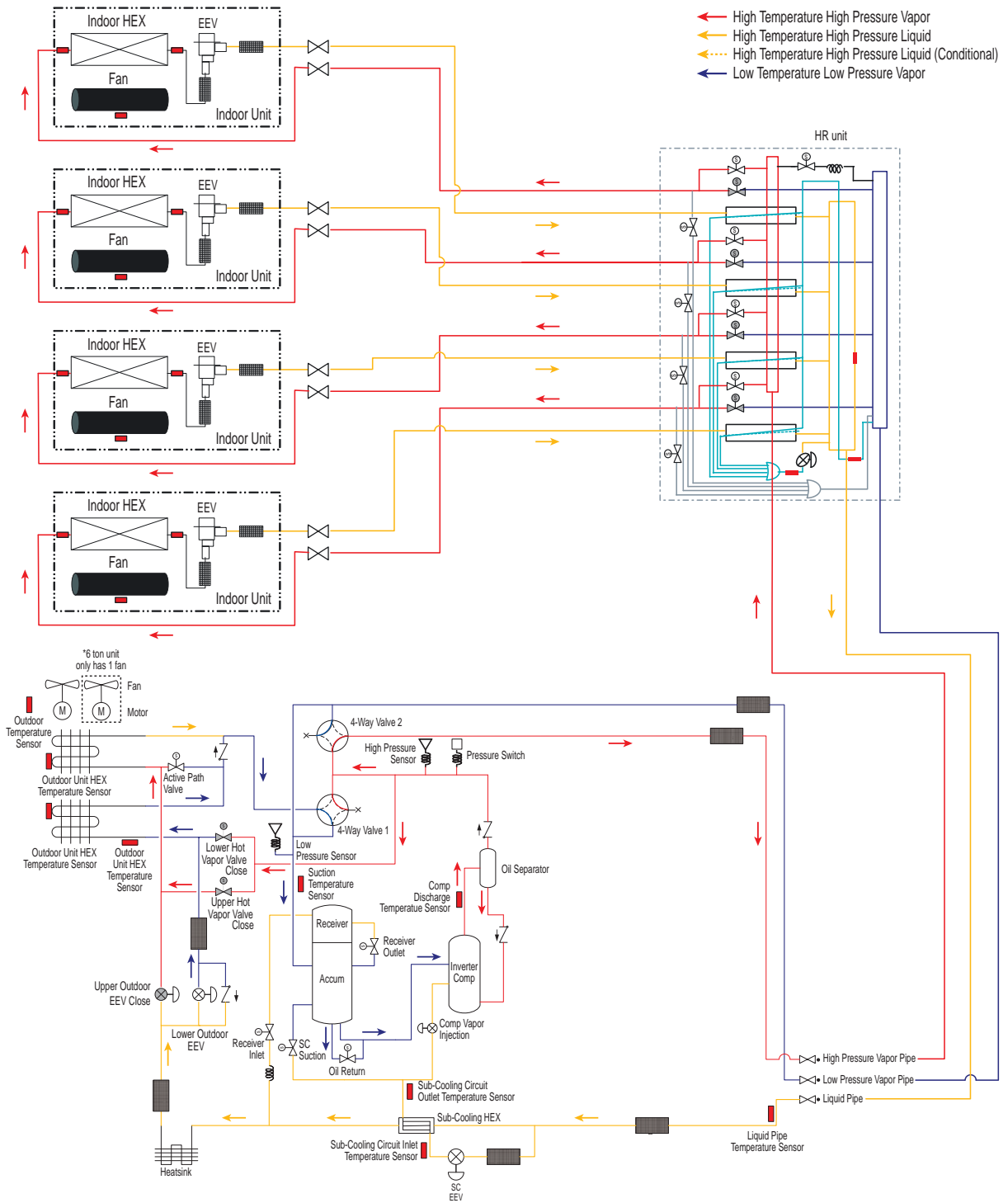

Remarks	Pressure Sensor	Temperature Sensor	Check Valve	Solenoid Valve
	Pressure Switch	SVC Valve	EEV	Strainer

Heat Recovery – Cooling Mode

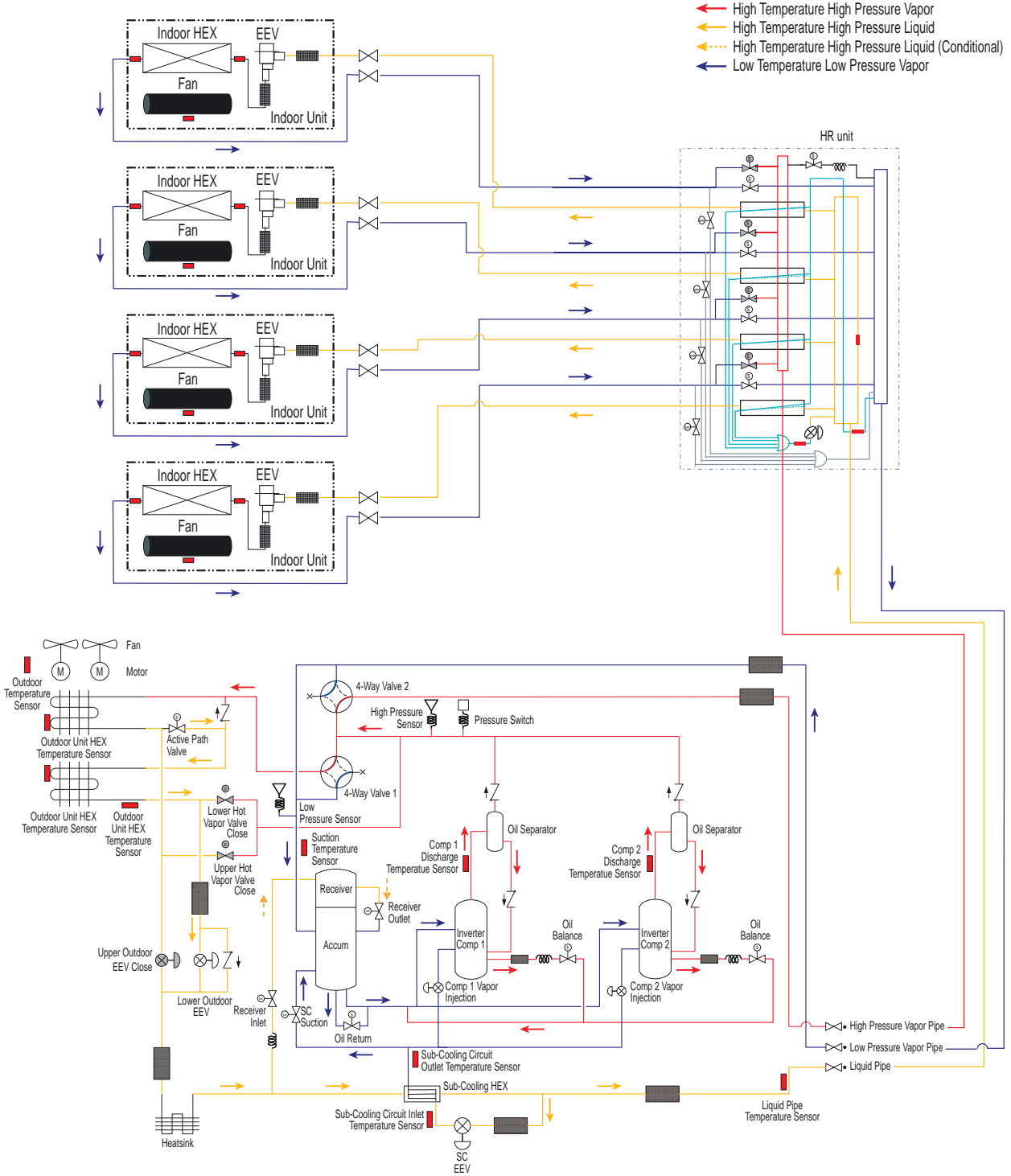

Outdoor Unit Functions

Remarks		Pressure Sensor		Temperature Sensor		Check Valve		Solenoid Valve
		Pressure Switch		SVC Valve		EEV		Strainer

# REFRIGERANT FLOW DIAGRAMS

**MULTI V 5**

ARUM144BTE5/DTE5, 168BTE5/DTE5, 192BTE5/DTE5, 216BTE5/DTE5, 241BTE5/DTE5  
Heat Recovery Operation — Heating Mode

## Heat Recovery – Heating Mode

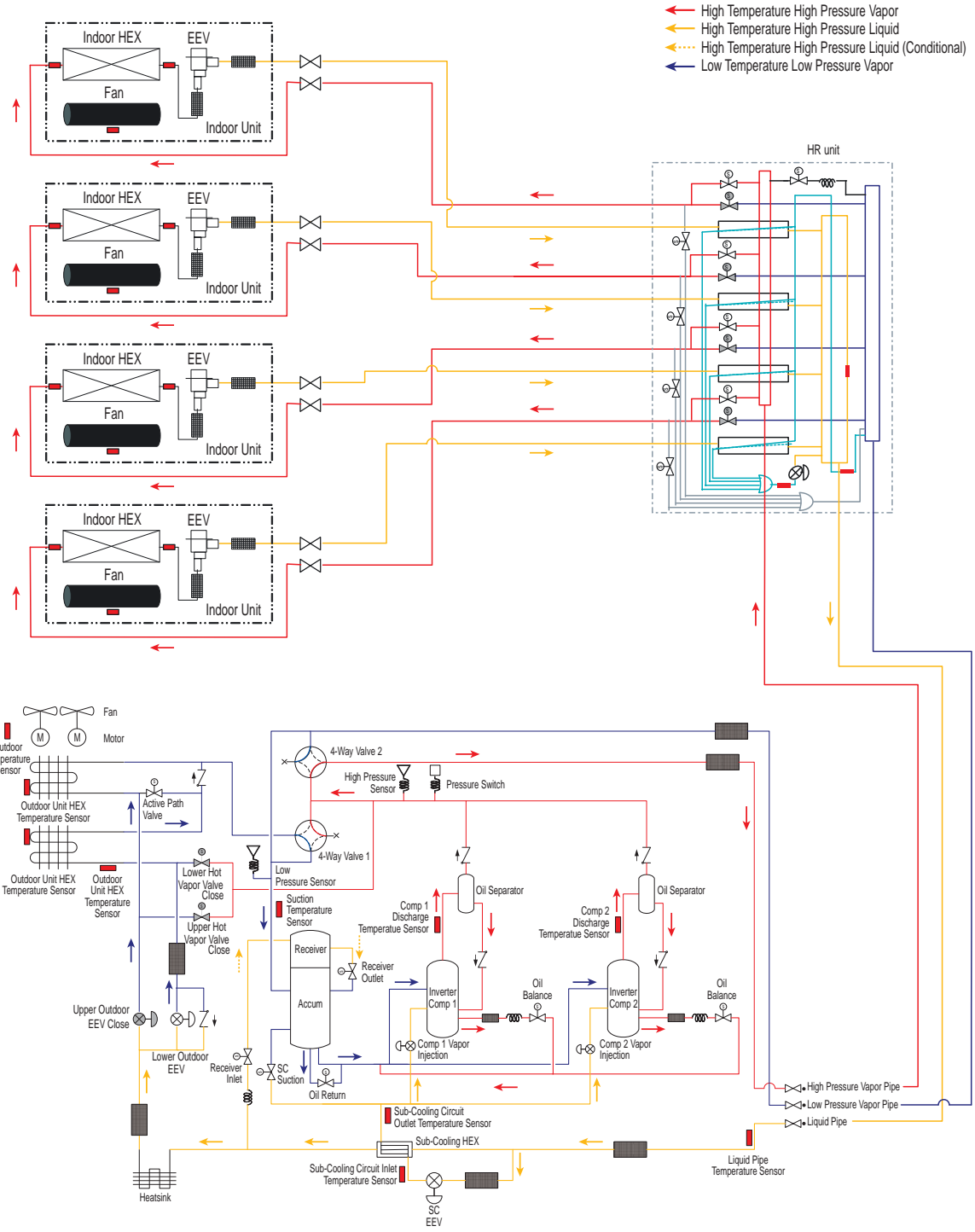

Remarks	Pressure Sensor	Temperature Sensor	Check Valve	Solenoid Valve
	Pressure Switch	SVC Valve	EEV	Strainer

MULTI V 5 Outdoor Unit Service Manual

**Heat Recovery – Cooling-Based Simultaneous Operation**

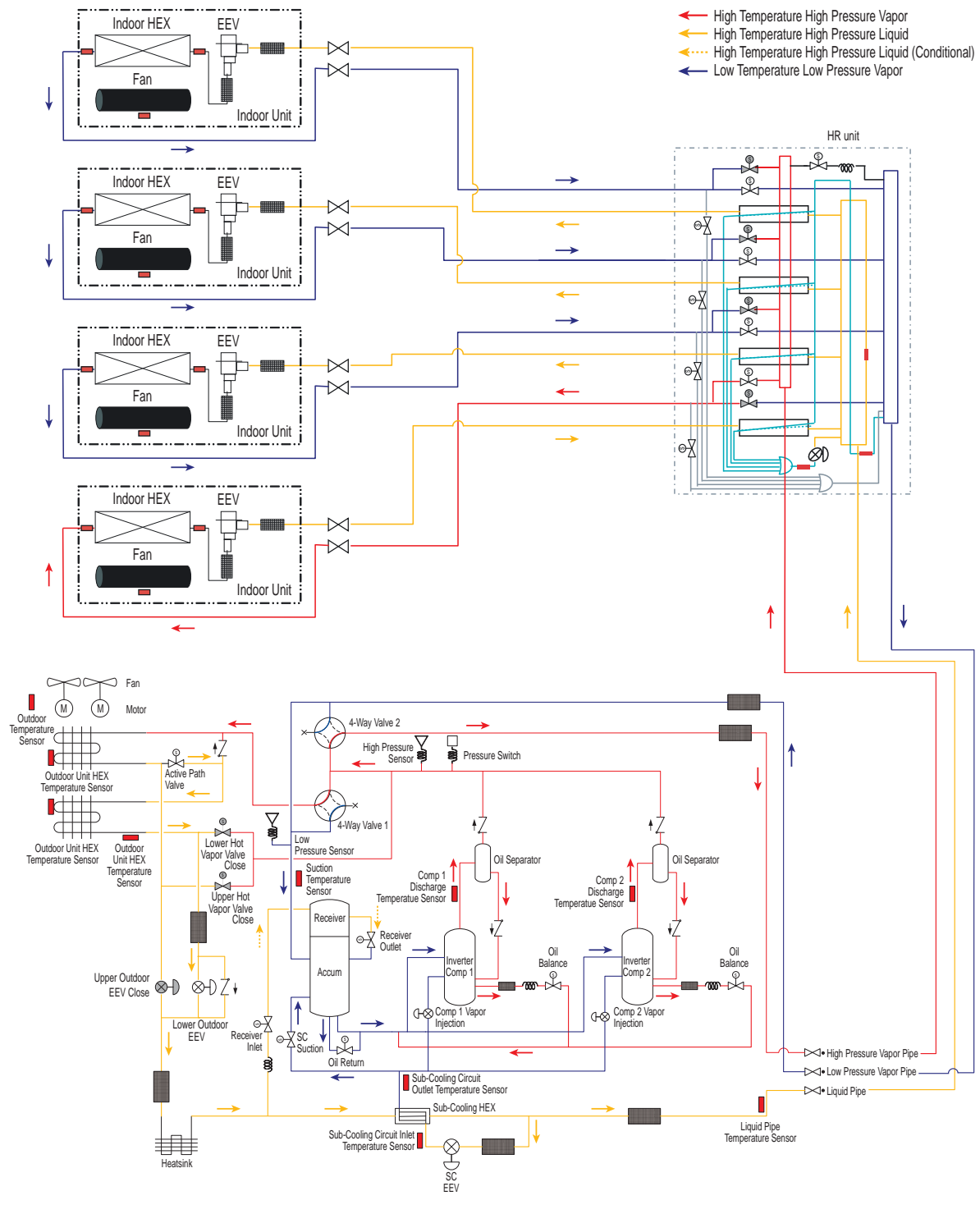

Outdoor Unit Functions

Remarks	Pressure Sensor	Temperature Sensor	Check Valve	Solenoid Valve
	Pressure Switch	SVC Valve	EEV	Strainer

# REFRIGERANT FLOW DIAGRAMS

**MULTI V 5**

ARUM144BTE5/DTE5, 168BTE5/DTE5, 192BTE5/DTE5, 216BTE5/DTE5, 241BTE5/DTE5  
Heat Recovery Operation — Heating-Based Simultaneous Mode

## Heat Recovery – Heating-Based Simultaneous Operation

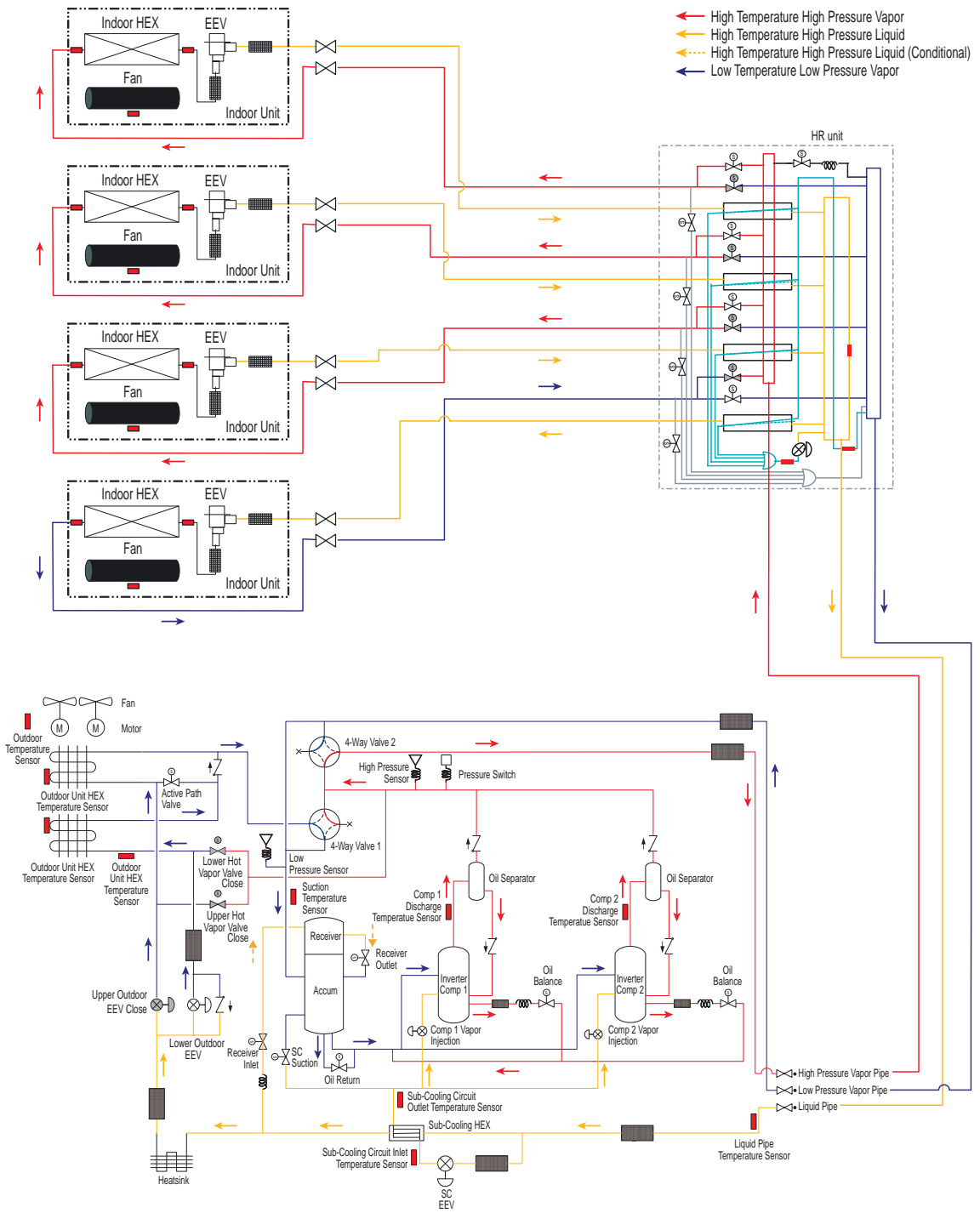

Remarks	Pressure Sensor	Temperature Sensor	Check Valve	Solenoid Valve
	Pressure Switch	SVC Valve	EEV	Strainer

MULTI V 5 Outdoor Unit Service Manual



**Heat Recovery – Balanced Simultaneous Operation**

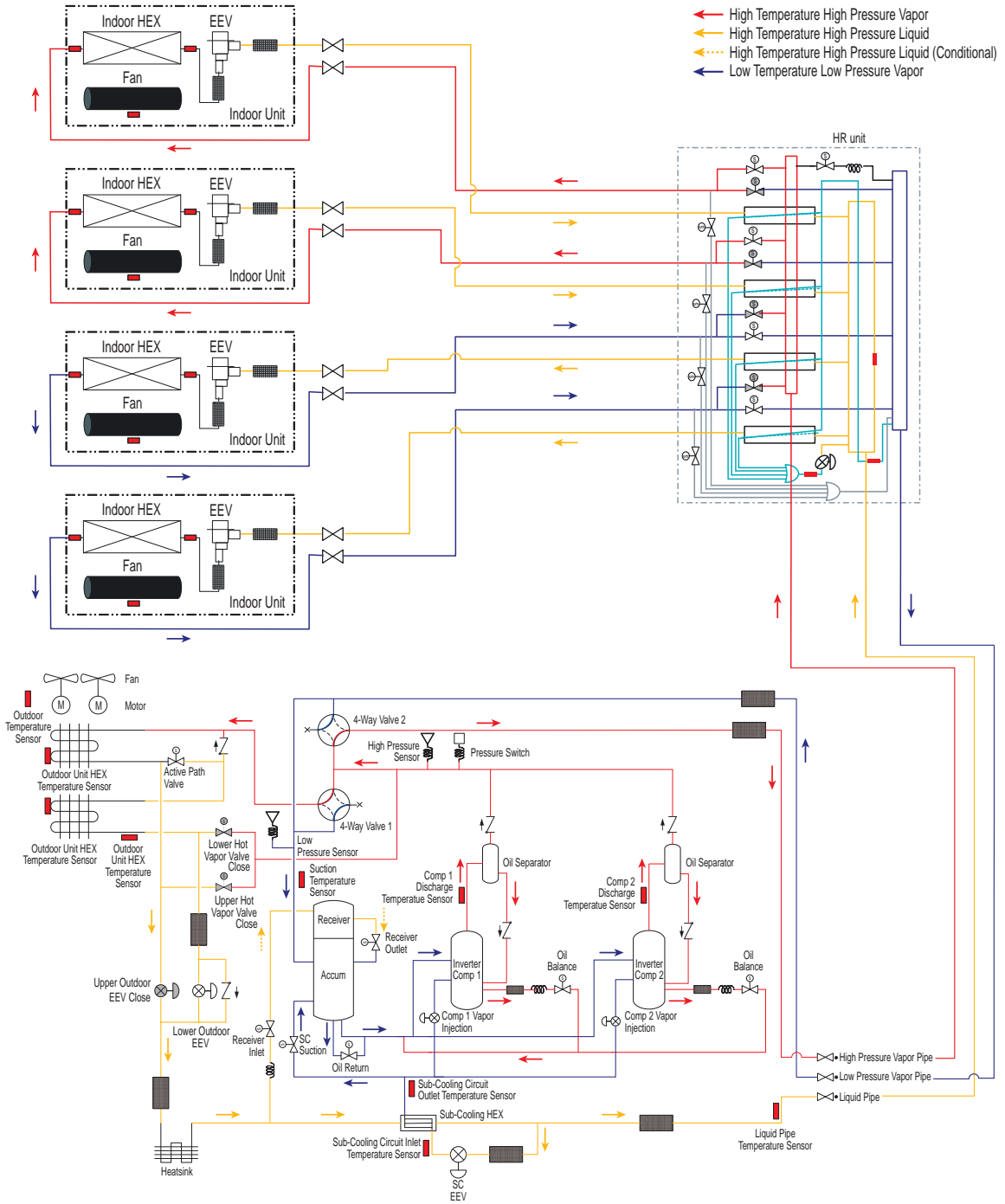

Outdoor Unit Functions

Remarks		Pressure Sensor		Temperature Sensor		Check Valve		Solenoid Valve
		Pressure Switch		SVC Valve		EEV		Strainer

# REFRIGERANT FLOW DIAGRAMS

**MULTI V 5**

ARUM144BTE5/DTE5, 168BTE5/DTE5, 192BTE5/DTE5, 216BTE5/DTE5, 241BTE5/DTE5  
Heat Recovery Operation — Oil Return and Defrost

## Heat Recovery – Oil Return and Defrost Operation

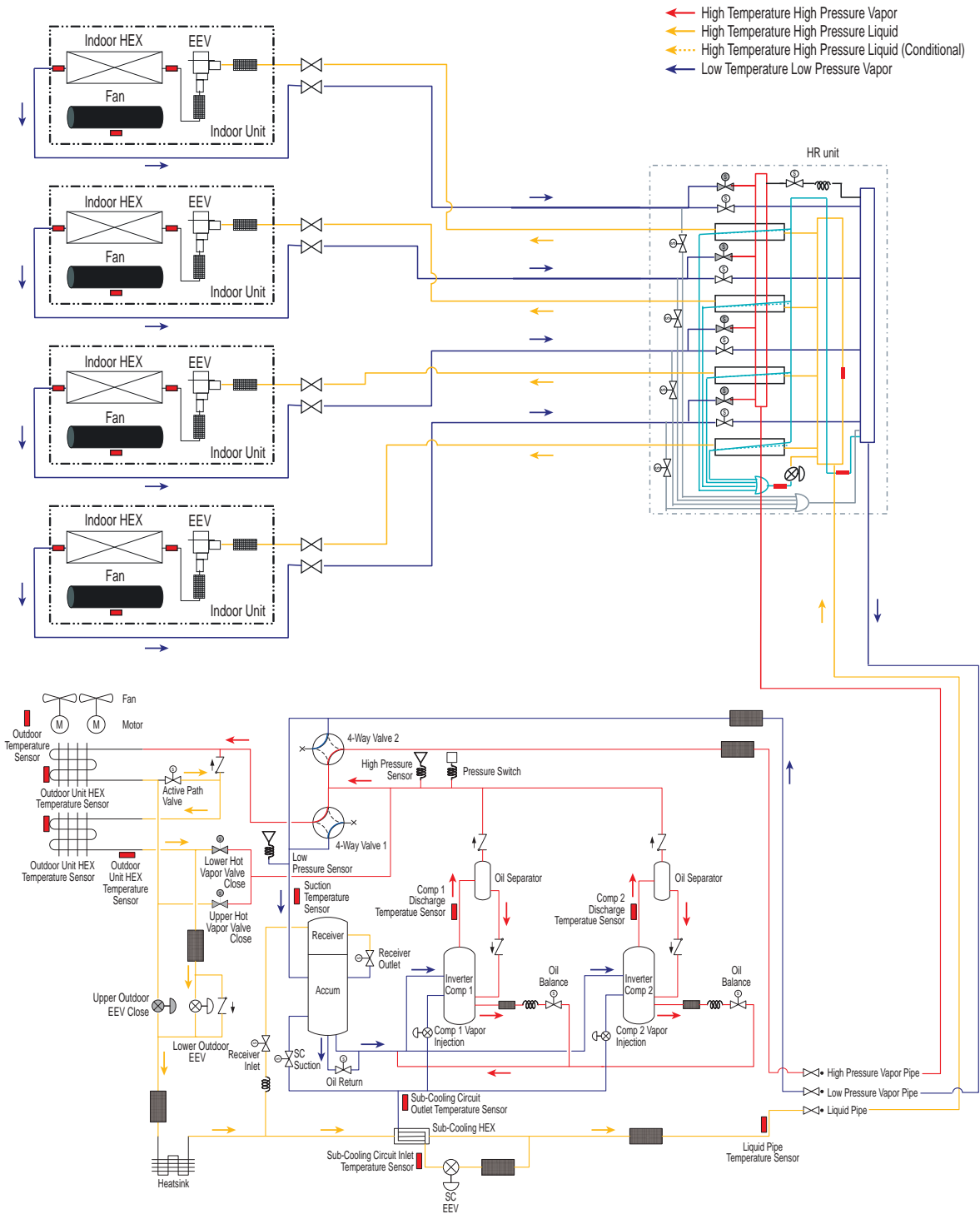

Remarks		Pressure Sensor		Temperature Sensor		Check Valve		Solenoid Valve
		Pressure Switch		SVC Valve		EEV		Strainer

MULTI V 5 Outdoor Unit Service Manual

**Heat Recovery – Lower HEX Defrost Operation**

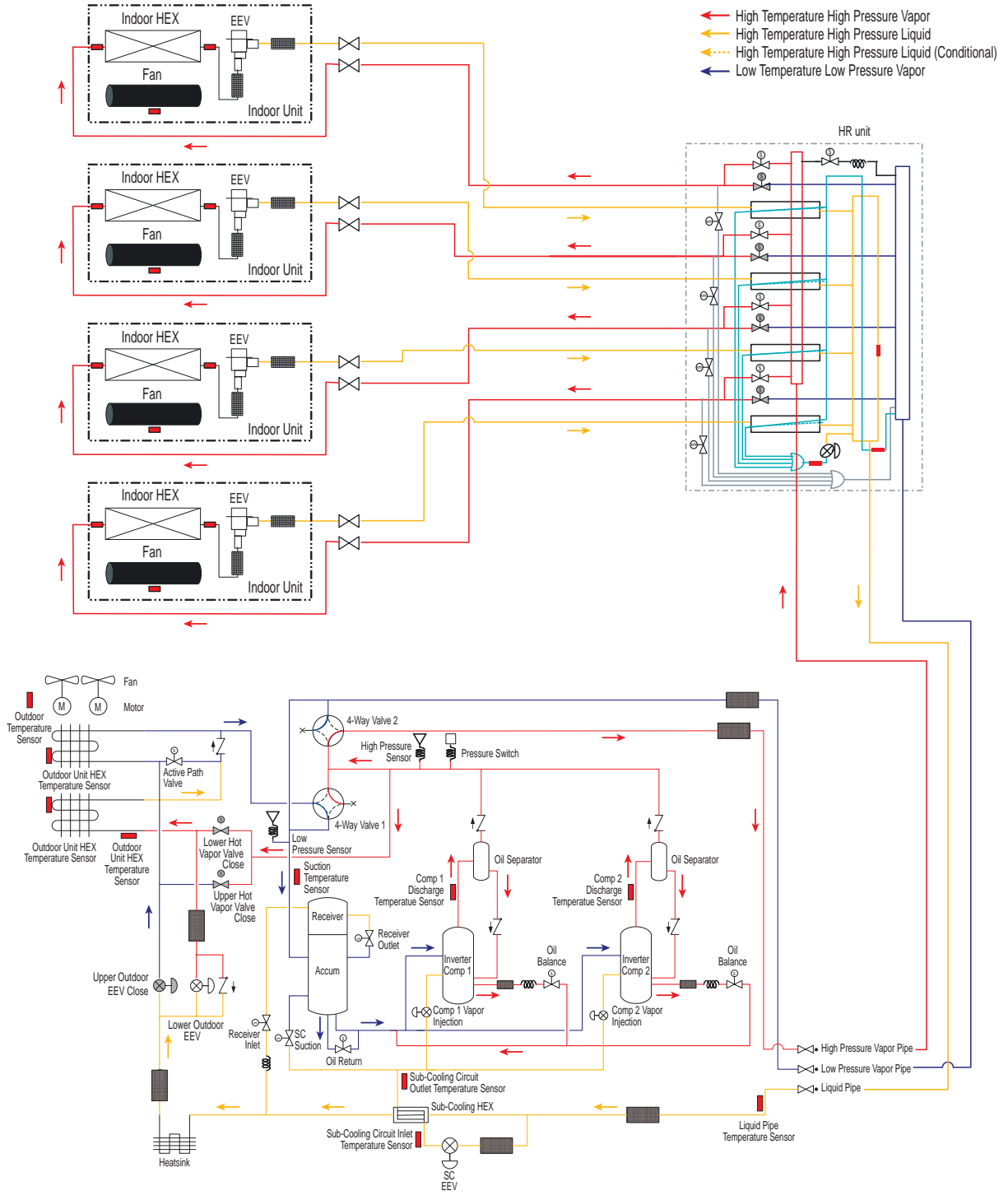

Outdoor Unit Functions

Remarks		Pressure Sensor		Temperature Sensor		Check Valve		Solenoid Valve
		Pressure Switch		SVC Valve		EEV		Strainer

# REFRIGERANT FLOW DIAGRAMS

**MULTI V 5**

ARUM144BTE5/DTE5, 168BTE5/DTE5, 192BTE5/DTE5, 216BTE5/DTE5, 241BTE5/DTE5  
Heat Recovery Operation — Upper Heat Exchanger Defrost Operation

## Heat Recovery – Upper HEX Defrost Operation

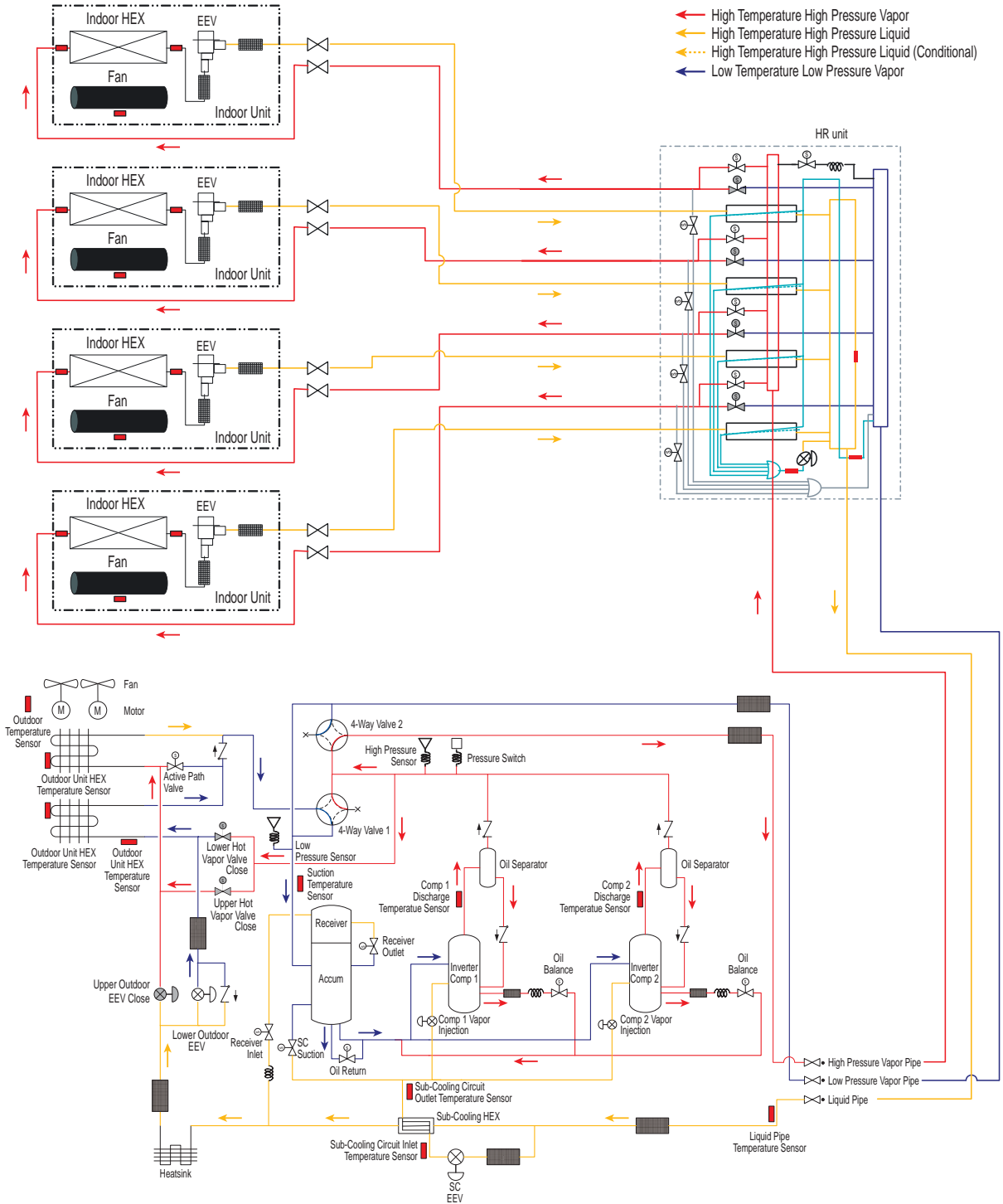

Remarks		Pressure Sensor		Temperature Sensor		Check Valve		Solenoid Valve
		Pressure Switch		SVC Valve		EEV		Strainer

MULTI V 5 Outdoor Unit Service Manual

**Normal Operation**

Table 1: Normal Operation Functions.

Component	Cooling Operation	Heating Operation	System Not in Operation
Compressor	Fuzzy Logic	Fuzzy Logic	Stop
Fan	Fuzzy Logic	Fuzzy Logic	Stop
Main EEV	Higher: Minimum Pulse Lower: Fully Open	Fuzzy Logic	Minimum Pulse
Subcooling EEV	Fuzzy Logic	• Normal: Vapor Injection Control • Avoiding control of high discharge temperature	Minimum Pulse
Indoor Unit EEV	Superheat Fuzzy Logic	Subcool Fuzzy Logic	Minimum Pulse

**Note:**

Heating mode does not operate when outside air temperature is >81°F and head pressure is >514 psi.

**Compressor Control**

Fuzzy logic helps ensure stable system performance by maintaining a constant evaporating temperature (Te) in cooling mode, and a constant condensing temperature (Tc) in heating mode. Both Te (cooling) and Tc (heating) can be set at various steps in the installation mode.

- Cooling Mode (Te): 35.6~41°F
- Heating Mode (Tc): 116.6~123.8°F

**Note:**

Te and Tc can be determined simultaneously by setting DIP switches.

Figure 1: Fuzzy Logic Diagram.

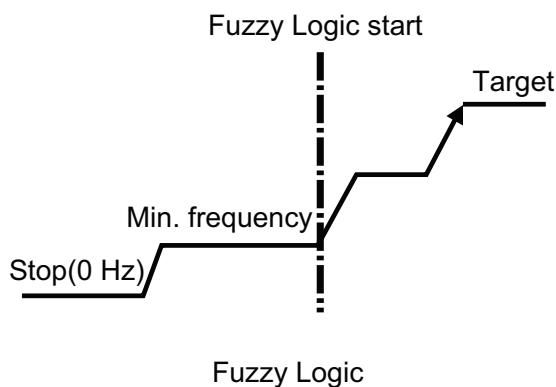
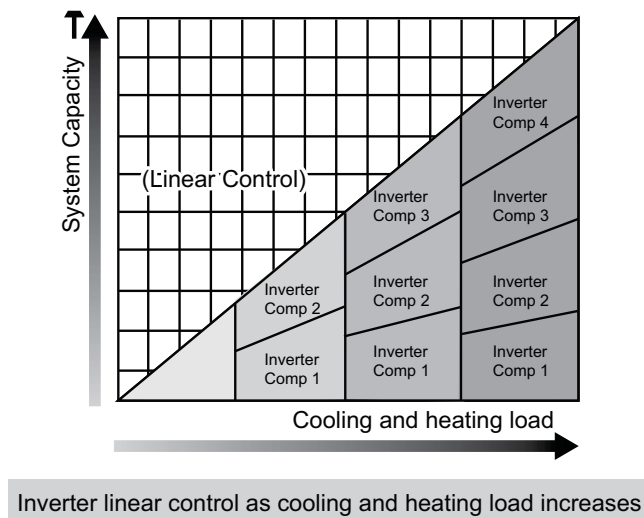

Figure 2: Inverter Linear Control Chart.



### Master and Slave Outdoor Unit EEV Control

#### Main EEV Control

Main EEV operates with fuzzy logic to keep the degree of superheat (about 37.4°F) at the evaporator outlet stable during heating mode.

Degree of Superheat =  $T_{\text{suction}} - T_{\text{evaporation}}$

where,

- $T_{\text{suction}}$  = Temperature measured at the suction pipe sensor (°F).
- $T_{\text{evaporation}}$  = Evaporation temperature equivalent to low pressure (°F).

#### Subcooling EEV Control

Subcooling EEV operates with fuzzy logic to keep the degree of subcool (about 59°F) at the outlet of the subcooler stable during cooling mode.

Degree of Subcool =  $T_{\text{condensation}} - T_{\text{liquid}}$

where,

- $T_{\text{liquid}}$  = Temperature at the outlet of the subcooler (°F).
- $T_{\text{condensation}}$  = Condensation temperature equivalent to high pressure (°F).

#### Avoiding Excessively High Discharge Temperatures

After the main EEV opens to a predetermined amount (R410A: 800 pulses), and the discharge temperature is above 185°F in heating mode, subcooling EEV control will operate to maintain compressor superheat.

#### Vapor Injection Flow Rate Control During Heating Mode

The degree of Superheat ( $VI_{\text{SH}}$ ) = Subcooler out (°F) – Subcooler in (°F)

where

- $T_d \leq 176^\circ\text{F}$  :  $VI_{\text{SH}} = 37.4^\circ\text{F}$
- $176^\circ\text{F} < T_d \leq 194^\circ\text{F}$  :  $VI_{\text{SH}} = -2 \times T_d/10 + 66.2^\circ\text{F}$
- $194^\circ\text{F} > T_d$  :  $VI_{\text{SH}} = 33.8^\circ\text{F}$

### Fan Motor Control

Fan motor operates using Fuzzy logic.

**Oil Return Control**

Oil return operation recovers any oil that has accumulated in the piping and returns it to the compressor. Each component operates as shown in the tables below during oil return.

**Oil Return in Cooling Mode**

Table 2: Outdoor Unit Oil Return Control in Cooling Mode.

Component	Start	During Oil Return Operation	Stop
Inverter Compressor	30Hz	Set Value	30Hz
Fan	Normal Control	Normal Control	Normal Control
Main EEV	Upper: Minimum Pulse Lower: Maximum Pulse	Upper: Minimum Pulse Lower: Maximum Pulse	Upper: Normal Control Lower: Normal Control
Subcooling EEV	Minimum Pulse	20 Pulse	80 Pulse
Four-Way Valve 1	Off	Off	Off
Four-Way Valve 2	Heat Pump: On Heat Recovery: Off	Off	Off

Table 3: Indoor Unit Oil Return Control in Cooling Mode.

Component	Start	During Oil Return Operation	Stop
Fan	Normal Control	Off	Normal Control
Thermo On Unit EEV	Normal Control	Normal control	Normal Control
Thermo Off Unit EEV	40 Pulse	400 Pulse	40 Pulse
Oil Return Signal	Off	On	Off

- Start: Oil Return Operation begins when the oil sensor continuously measures low oil levels.
- Oil Return Operation will run for three (3) minutes.
- Stop: Oil Return Operation will end if / when compressor protection control starts.

**Oil Return Control in Heating Mode**

Table 4: Outdoor Unit Oil Return Control in Heating Mode.

Component	Start	During Oil Return Operation	Stop
Inverter Compressor	30Hz	Set Value	40Hz
Fan	Normal Control	Normal Control	Normal Control
Main EEV	Upper: Minimum Pulse Lower: Maximum Pulse	Upper: Minimum Pulse Lower: Maximum Pulse	Upper: Normal Control Lower: Normal Control
Subcooling EEV	Minimum Pulse	20 Pulse	80 Pulse
Four-Way Valve 1	On	Off	On
Four-Way Valve 2	Heat Pump: Off Heat Recovery: Off	Off	Off

Table 5: Indoor Unit Oil Return Control in Heating Mode.

Component	Start	During Oil Return Operation	Stop
Fan	Normal Control	Off	Normal Control
Thermo On Unit EEV	Normal Control	400~800 Pulse	Normal Control
Thermo Off Unit EEV	80~130 Pulse	400~800 Pulse	80~130 Pulse

- Start: Oil Return Operation begins when the oil sensor continuously measures low oil levels.
- Oil Return Operation will run for three (3) minutes.
- Stop: Oil Return Operation will end if / when compressor protection control starts.

## Defrost Control / Partial Defrost Control

### Defrost Control

Defrost Control eliminates ice that has accumulated on the heat exchanger, recovering its performance. Each component operates as shown in the tables below during defrost.

Table 6: Outdoor Unit Defrost Control.

Component	Start	During Defrost Control Operation	Stop
Inverter Compressor	30Hz	Set Value	40Hz
Fan	Stop	High Pressure control	Normal Control
Main EEV	Normal Control	Maximum Pulse	Normal Control
Subcooling EEV	Normal Control	Minimum Pulse	Normal Control
Four-Way Valve 1	On to Off	Off	On
Four-Way Valve 2	Off	Off	Off
Upper Heat Exchanger	Off	Off	Off
Lower Heat Exchanger	On to Off	Off	Off

Table 7: Indoor Unit Defrost Control.

Component	Start	During Defrost Control Operation	Stop
Fan	Off	Off	Off
Thermo On Unit EEV	Normal Control	400~800 Pulse	Normal Control

### Defrost Control Stop Operation

1. All heat exchanger pipe temperatures are above set temperatures for thirty (30) seconds.
2. Defrost Control Operation will run for >30% of the total heating time (maximum twenty [20] minutes).
3. Defrost Control Operation will stop if / when compressor protection control starts (if a high discharge temperature at the compressor is detected).

### Partial Defrost

The heat exchanger in the outdoor unit(s) is divided into a top part and bottom part for partial defrost operation. Partial defrost operation permits the system to defrost the parts of the heat exchanger separately so heating mode can operate continuously. Each component operates as shown on the below table during partial defrost.

Table 8: Outdoor Unit Partial Defrost Control.

Component	Start	During Defrost Control Operation	Stop
Inverter Compressor	Normal Control	Set Value	Normal Control
Fan	Normal Control	Low Pressure control	Normal Control
Main EEV	Normal Control	Normal Control	Normal Control
Subcooling EEV	Normal Control	Normal Control	Normal Control
Four-Way Valve 1	On	On	On
Four-Way Valve 2	Off	Off	Off
Upper Heat Exchanger	Off	Off to On to On	Off
Lower Heat Exchanger	Off	On to Off to On	Off

Table 9: Indoor Unit Partial Defrost Control.

Component	Start	During Defrost Control Operation	Stop
Fan	ON (Setting)	ON (Low)	ON (Setting)
Thermo On Unit EEV	Normal Control	Normal Control	Normal Control

### Partial Defrost Control Stop Operation

1. Partial Defrost Control Operation will run for a maximum of twelve (12) minutes.
2. Partial Defrost Control Operation will stop for the upper heat exchanger when the temperature rises above the set temperature.
3. Partial Defrost Control Operation will stop for the lower heat exchanger when the temperature rises above the set temperature.

**Stop Operation Control**

Stop Operation Control in Cooling Mode

Table 10: Stop Operation Control in Cooling Mode.

Component	Stop Operation	Notes
Inverter Compressor	Off	-
Fan	Stop	-
Main EEV	32 Pulse	-
Subcooling EEV	16 Pulse	Stop (Minimum Pulse)
Four-Way Valve 1	Off	-
Four-Way Valve 2	Heat Pump: On Heat Recovery: Off	-

Stop Operation Control in Heating Mode

Table 11: Stop Operation Control in Heating Mode.

Component	Stop Operation	Notes
Inverter Compressor	Off	-
Fan	Stop	-
Main EEV	32 Pulse	-
Subcooling EEV	16 Pulse	Stop (Minimum Pulse)
Four-Way Valve 1	On	Off when air temperature is >86°F
Four-Way Valve 2	Off	-

**Oil Equalizing Control**

Oil equalizing control prevents oil imbalance between the inverter compressors. If the oil level sensors detect different oil levels between the compressors, then the oil equalizing solenoid valve will open for five (5) minutes (except for models with only one [1] compressor).

# PROTECTION CONTROL



## Pressure Protection Control

### Pressure Protection Control

#### Pressure Control in Cooling Mode

Table 12: High Pressure Control in Cooling Mode.

Pressure Range	Compressor	Fan
$P_d \geq 580.6$ psi	Stop	Stop
$P_d > 547.5$ psi	-15 Hz / 10 seconds	+100 RPM / 10 seconds
$P_d \geq 529.4$ psi	Frequency Hold*	+100 RPM / 10 seconds
$P_d \geq 504.7$ psi	+2 Hz or less / 10 seconds	+100 RPM / 10 seconds
$P_d < 504.7$ psi	Normal Control	

\* Frequency Hold = Frequency (or RPM) is not increasing (can decrease).

Table 13: Low Pressure Control in Cooling Mode.

Pressure Range	Compressor	Fan
$P_s \leq 18.9$ psi	Stop (one [1] minute later)	Stop
$P_s \leq 21.8$ psi	-15 Hz / 10 seconds	-100 RPM / 10 seconds
$P_s > 21.8$ psi	Frequency Hold*	-100 RPM / 10 seconds
$P_s > 23.2$ psi	+2 Hz or less / 10 seconds	-100 RPM / 10 seconds
$P_s > 27.6$ psi	+2 Hz or less / 10 seconds	-100 RPM / 10 seconds
$P_s > 31.9$ psi	Normal Control	

\* Frequency Hold = Frequency (or RPM) is not increasing (can decrease).

#### Pressure Control in Heating Mode

Table 14: High Pressure Control in Heating Mode.

Pressure Range	Compressor	Fan
$P_d \geq 580.6$ psi	Stop	Stop
$P_d > 495.3$ psi	-15 Hz / 10 seconds	-50 RPM / 10 seconds

Table 15: Low Pressure Control in Heating Mode.

Pressure Range	Compressor	Fan
$P_s \leq 14.2$ psi	Stop	Stop
$P_s \leq 18.0$ psi	-15 Hz / 10 seconds	+100 RPM / 10 seconds
$P_s \leq 19.9$ psi	Frequency Hold*	+100 RPM / 10 seconds
$P_s \leq 27.6$ psi	+2 Hz or less / 10 seconds	+100 RPM / 10 seconds
$P_s \geq 27.6$ psi	Normal Control	Normal Control

\* Frequency Hold = Frequency (or RPM) is not increasing (can decrease).

**Discharge Temperature Control**

Table 16: Outdoor Unit Discharge Temperature Control.

Temperature Range	Compressor	Subcooling EEV	Indoor Unit EEV
Tdis > 235.4°F	-5 Hz / 10 seconds	SC, SH Decrease Control	SH Decrease Control
Tdis > 230°F	-5 Hz / 10 seconds	SC, SH Decrease Control	SH Decrease Control
Tdis ≥ 221°F	Frequency Hold*	SC, SH Decrease Control	SH Decrease Control
Tdis ≤ 212°F	+3 Hz or less	SC, SH Decrease Control	SH Decrease Control
Tdis > 212°F	Normal Control	SC, SH Decrease Control	SH Decrease Control

\* Frequency Hold = Frequency (or RPM) is not increasing (can decrease). Tdis = Temperature Discharge. SH = Superheating.  
SC = Subcooling.

**Inverter Compressor Protection Control**

The tables below display the amperage where the system will operate normally, the amperage where the inverter protection control will cause the frequency to drop, and the amperage where the inverter protection control will shut the system off. AC input current is measured at the inverter compressor (after the point where the current passes through the noise filter).

Table 17: Inverter Protection Control for 208-230V Outdoor Units (ARUM\*\*\*BTE5).

Current Type	Chassis	Tons	Compressor (HP)	Cooling & Heating					
				Normal System Operation		Frequency Will Drop		System Will Stop Operation	
				Comp. 1	Comp. 2	Comp. 1	Comp. 2	Comp. 1	Comp. 2
AC Input Current <sup>1</sup>	ARUM072BTE5	6	4.8	33A or less	-	33A or more	-	35A or more	-
	ARUM096BTE5	8	6.8	37A or less	-	37A or more	-	40A or more	-
	ARUM121BTE5	10	6.8	37A or less	-	37A or more	-	40A or more	-
	ARUM144BTE5	12	4.8 / 4.8	33A or less	33A or less	33A or more	33A or more	35A or more	35A or more
	ARUM168BTE5	14	4.8 / 4.8	33A or less	33A or less	33A or more	33A or more	35A or more	35A or more
	ARUM192BTE5	16	6.8 / 6.8	37A or less	37A or less	37A or more	37A or more	40A or more	40A or more
	ARUM216BTE5	18	6.8 / 6.8	37A or less	37A or less	37A or more	37A or more	40A or more	40A or more
Compressor Current	ARUM241BTE5	20	6.8 / 6.8	37A or less	37A or less	37A or more	37A or more	40A or more	40A or more
	ARUM072BTE5	6	4.8	36A or less	-	36A or more	-	46A or more	-
	ARUM096BTE5	8	6.8	49A or less	-	49A or more	-	60A or more	-
	ARUM121BTE5	10	6.8	49A or less	-	49A or more	-	60A or more	-
	ARUM144BTE5	12	4.8 / 4.8	36A or less	36A or less	36A or more	36A or more	46A or more	46A or more
	ARUM168BTE5	14	4.8 / 4.8	36A or less	36A or less	36A or more	36A or more	46A or more	46A or more
	ARUM192BTE5	16	6.8 / 6.8	49A or less	49A or less	49A or more	49A or more	60A or more	60A or more
ARUM216BTE5	18	6.8 / 6.8	49A or less	49A or less	49A or more	49A or more	60A or more	60A or more	
ARUM241BTE5	20	6.8 / 6.8	49A or less	49A or less	49A or more	49A or more	60A or more	60A or more	

Table 18: Inverter Protection Control for 460V Outdoor Units (ARUM\*\*\*DTE5).

Current Type	Chassis	Tons	Compressor (HP)	Cooling & Heating					
				Normal System Operation		Frequency Will Drop		System Will Stop Operation	
				Comp. 1	Comp. 2	Comp. 1	Comp. 2	Comp. 1	Comp. 2
AC Input Current <sup>1</sup>	ARUM072DTE5	6	4.8	18A or less	-	18A or more	-	20A or more	-
	ARUM096DTE5	8	6.8	25A or less	-	25A or more	-	27A or more	-
	ARUM121DTE5	10	6.8	25A or less	-	25A or more	-	27A or more	-
	ARUM144DTE5	12	4.8 / 4.8	18A or less	17A or less	18A or more	17A or more	20A or more	19A or more
	ARUM168DTE5	14	4.8 / 4.8	18A or less	17A or less	18A or more	17A or more	20A or more	19A or more
	ARUM192DTE5	16	6.8 / 6.8	25A or less	25A or less	25A or more	25A or more	27A or more	27A or more
	ARUM216DTE5	18	6.8 / 6.8	25A or less	25A or less	25A or more	25A or more	27A or more	27A or more
Compressor Current	ARUM241DTE5	20	6.8 / 6.8	25A or less	25A or less	25A or more	25A or more	27A or more	27A or more
	ARUM072DTE5	6	4.8	20A or less	-	20A or more	-	30A or more	-
	ARUM096DTE5	8	6.8	29A or less	-	29A or more	-	41A or more	-
	ARUM121DTE5	10	6.8	29A or less	-	29A or more	-	41A or more	-
	ARUM144DTE5	12	4.8 / 4.8	20A or less	20A or less	20A or more	20A or more	30A or more	30A or more
	ARUM168DTE5	14	4.8 / 4.8	20A or less	20A or less	20A or more	20A or more	30A or more	30A or more
	ARUM192DTE5	16	6.8 / 6.8	29A or less	29A or less	29A or more	29A or more	41A or more	41A or more
ARUM216DTE5	18	6.8 / 6.8	29A or less	29A or less	29A or more	29A or more	41A or more	41A or more	
ARUM241DTE5	20	6.8 / 6.8	29A or less	29A or less	29A or more	29A or more	41A or more	41A or more	

<sup>1</sup>AC input current is the inverter compressor input current (except constant current: current passing through the noise filter.)

## Initial Setup

### Initial Setup

There are four (4) initial setup steps before operation can begin. All DIP switch settings must be completed before initial setup.

#### Step 1

Factory set value is displayed on the PCB seven segment display (SSD) for twenty-four (24) seconds.

Turn power on.

Code for the Master outdoor unit is displayed for three (3) seconds.

**22**

Code for the Slave 1 outdoor unit is displayed for three (3) seconds.

**14**

Code for the Slave 2 outdoor unit is displayed for three (3) seconds.

**12**

Total system capacity (master and slave units) is displayed for two (2) seconds.

**48**

System type is displayed (3 is default).

- Heat Pump = 2
- Heat Recovery = 3

**3**

Electrical requirements are displayed.

- 208-230V = 22
- 460V = 46

**46**

Model Type.

**30**

#### Step 2

Communication Check: If display follows all sequences as shown above, the communication between the Master and Slave outdoor units is normal. If the SSD shows Error Code 104\*, check the DIP switch settings and the communication cables between the Master and Slave outdoor units.

#### Step 3

PCB Error Check: Error check will begin after forty (40) seconds.

Master / Slave unit

- All errors of all the units (including Slave) will be shown on the SSD.
- If communication between main PCB and inverter PCB isn't correct, Error Code 52\* will be seen on the SSD.
- If communication between main PCB and fan PCB isn't normal, Error Code 105\* will be seen on the SSD.
- If any errors are displayed, check corresponding wires / cables.

**Initial Setup, Continued.**

## Step 4: Indoor Unit Auto Addressing Procedure

**⚠ WARNING**

Disconnects must only be operated by a properly licensed electrician at this time. ⚡ Never look at a disconnect switch when closing. Turn away from the switch when closing. Incorrect wiring could cause the disconnect to explode, physical injury, and / or death.

**Note:**

- Supply power to the indoor units. If power is not supplied, an operation error will occur.
- During the pre-commissioning process for systems with Gen 4 indoor units, ⚡ do not change any DIP switch settings except for No. 3 on SW01B, which must be ON to enable Gen. 4 features. All other combinations of switches (one [1] through seven [7]) must be left in the OFF position on the outdoor unit DIP switch bank SW01B. Refer to System Combinations and Outdoor Unit Operation Settings for proper setting of No. 3 on SW01B.
- If the Auto Address Procedure has never been successfully completed for the system, the compressor(s) will not start when power is applied to the unit.
- Auto addressing is only possible on the main PCB of the outdoor unit (master unit if dual / triple frame system).
- If an indoor unit PCB has been replaced, the auto addressing procedure must be performed again.

1. Verify all that all indoor units connected to the system have power to the PCB board AND all wired controller system start buttons are OFF.
2. Remove the maintenance access panel and unit control box cover from the outdoor unit. Place panels and screws in a secure area.
3. Verify that the communications cable between the indoor units and the outdoor unit is terminated at the outdoor unit terminals IDU(A) and IDU (B).
4. Verify the shield on the communications cable is grounded at the outdoor unit.
5. If installing a dual- or triple-frame system, verify which outdoor unit will be the "Master" unit, the Slave1 unit, and the Slave2 unit; check if the DIP switches on DIP-SW01 are set properly. (See "Setting Outdoor Units in Dual / Triple Frame Systems" under "Pre-Commissioning / Outdoor Unit DIP Switch Settings" earlier in this section.)
6. Cycle power on the outdoor units, indoor units, etc., and wait three (3) minutes while the outdoor unit sequences through the self-diagnostics check, and to improve indoor unit communication when initial power is supplied. Leave disconnect in the "ON" position.
7. Check the outdoor unit(s) current configuration code(s). Observe the unit setup codes using the SSD display found on the outdoor unit PCB.

**Note:**

After the self-diagnostics check is complete, the SSD is clear with nothing displayed. Diagnostic process could take from three (3) to seven (7) minutes.

8. Know how many indoor units are connected to the system.
9. Press and hold the red SW01C button for about five (5) seconds. Release when "88" appears on the SSD of the master outdoor unit PCB. After three (3) to seven (7) minutes, the display will flash a number for about thirty (30) seconds, indicating how many total indoor units the system successfully communicated with.
10. This number must match the known installed number of indoor units if the auto addressing procedure was successful. If using LGMV, read the address of each indoor unit. The address of each indoor unit is also indicated on wired remote control displays.
11. Upon completion of the auto addressing routine, the display will be blank and the system will be in standby waiting for another command.
12. Upon successful completion of the auto address procedure, record the system address assigned to each indoor unit by the auto address procedure in the column provided on the Pre-Commissioning Device Configuration Worksheet.

## Initial Setup

### Indoor Unit Auto Addressing Procedure, continued.

13. After recording the system addresses assigned to each device, open the outdoor unit disconnect. Remove the outdoor unit to indoor unit communications cable from terminals IDU(A) and IDU(B). Protect conductors by placing electrical tape over the bare ends.
14. Close the disconnect to reapply power to the outdoor unit and energize the compressor crankcase heater. Once again, verify that the outdoor unit to indoor unit(s) communications cable is not connected to terminals IDU(A) and IDU(B) of the outdoor unit.
15. Replace the control panel door.

### **⚠ WARNING**

Upon successful completion of the auto addressing function, an unintentional compressor start can occur unless the communications cable to the indoor units is removed from the outdoor unit terminals IDU(A) and IDU(B). **Do NOT** open the service valves or attempt to start outdoor unit compressors or until directed by the LG trained commissioner. Major damage to the unit piping and compressors will occur, and there is a risk of explosion, suffocation, physical injury, and / or death.

Figure 4: Auto Addressing Flowchart.

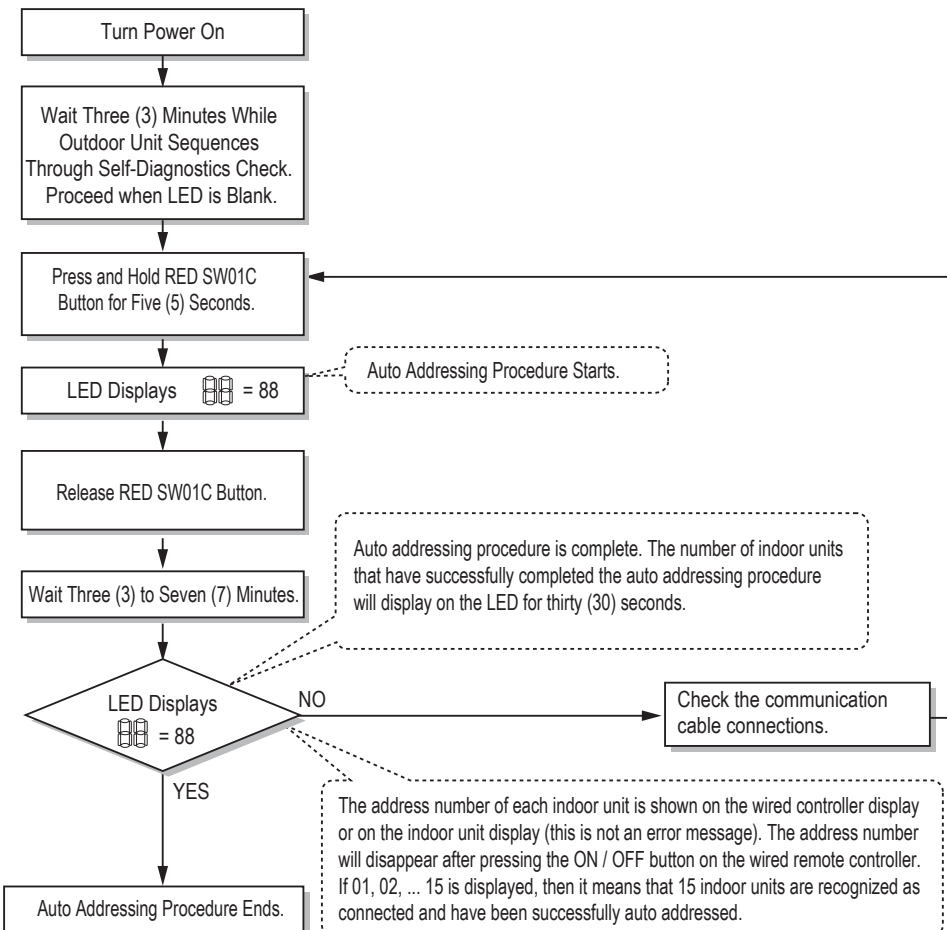
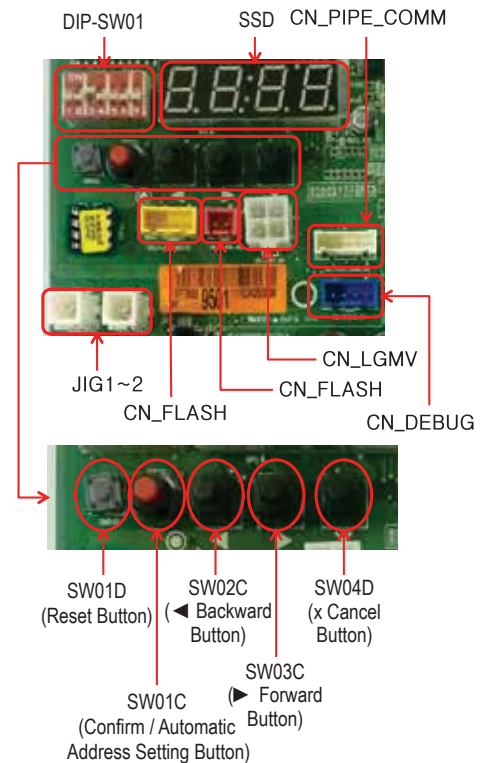

Figure 3: Auto Addressing Button Location on Outdoor Unit PCB.



**Troubleshooting a Failed Indoor Unit Auto Addressing Procedure**

If the quantity of indoor units the auto addressing procedure found is incorrect, or the “88” never disappears from the display for the seven (7) minutes, the auto address procedure has failed and a communications problem exists. If the Auto Address Procedure failed:

1. Verify ALL indoor unit ON/OFF buttons are in the OFF position (i.e., ON / OFF button NOT illuminated).
2. Check the terminations, polarity, and continuity of each conductor on the communications cable between the outdoor unit and the indoor units. Verify the indoor unit to outdoor unit communications cable is wired correctly.
  - Verify the conductor connected to the “3” (or “5” in the case of cassette frame codes TP, TN, TM) terminals on all indoor units and is terminated on the outdoor unit terminal tagged IDU(A).
  - In a similar fashion, verify the conductor connected to all indoor units on the “4” (or “6” in the case of cassette chassis codes TP, TN, TM) terminals and is terminated on the outdoor unit terminal tagged IDU(B).
3. Verify the shield of the communications cable is grounded at the outdoor unit only. All segment shields must be spliced together at each indoor unit and NOT grounded.
4. After repairing the communications cable, go to Step 9 of the Auto Addressing Procedure and repeat the process until successful: Press and hold the red SW01C button for about five (5) seconds. Release when “88” appears on the SSD. After three (3) to seven (7) minutes, the display will flash a number for about thirty (30) seconds indicating how many total indoor units the system successfully communicated with.
5. This number must match the known installed number of indoor units if the auto addressing procedure was successful.
6. Upon completion of the auto addressing routine, the display will be blank and the system will be in standby waiting for another command.
7. Record the system address the outdoor unit assigned to each indoor unit by the auto address procedure in the column provided on the Pre-commissioning Device Configuration Worksheet.
8. After recording the system addresses assigned to each device, open the outdoor unit disconnect. Remove the outdoor unit to indoor unit communications cable from terminals IDU(A) and IDU(B). Protect conductors by placing electrical tape over the bare ends to prevent an accidental compressor start from occurring before the LG trained commissioner arrives.
9. Close the disconnect to reapply power to the outdoor unit and energize the compressor crankcase heater. Once again, verify the outdoor unit to indoor unit(s) communications cable is not connected to terminals IDU(A) and IDU(B) of the outdoor unit.
10. Replace the control panel cover.

**Quick Control Setting**

Main PCB DIP switches are factory set to all OFF.

- Verify all indoor units are Generation 4 models.
- Change No. 3 on the Main PCB Dip switch bank DIP-SW01 from OFF to On.
- Push the SW01D reset button.

Figure 5: Quick Control Setting.

DIP Switch  
DIP-SW01    SSD

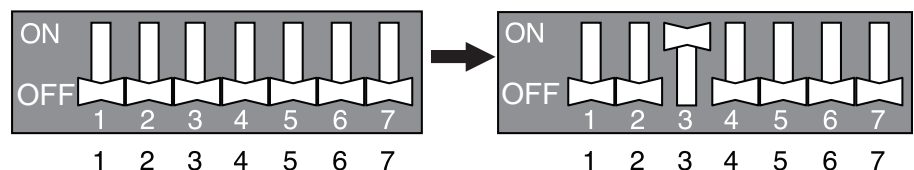

## Setting Optional Modes

### Setting the Optional Modes

To access and set the different modes, first turn No. 5 on the master outdoor unit PCB DIP switch bank SW01 to ON. Then, select the "Func", "Idu", or "Svc" mode by using the SW03C forward ► button and the SW02C backward ◀ button, and then press the SW01C confirm • button.

Figure 7: No. 5 on DIP Switch Bank SW01 ON.

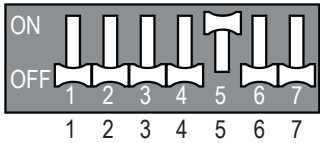

### Note:

- To set the optional modes / functions, all indoor units must be OFF. Mode / function settings won't save, nor will operate unless all indoor units are OFF.
- If system power was reset, some modes / function settings will be automatically saved in the EEPROM. Other modes / functions will reset when power is cycled off. See next pages for details on specific modes / functions.

Figure 6: Location of DIP Switches and Setting Buttons on the Outdoor Unit PCB.

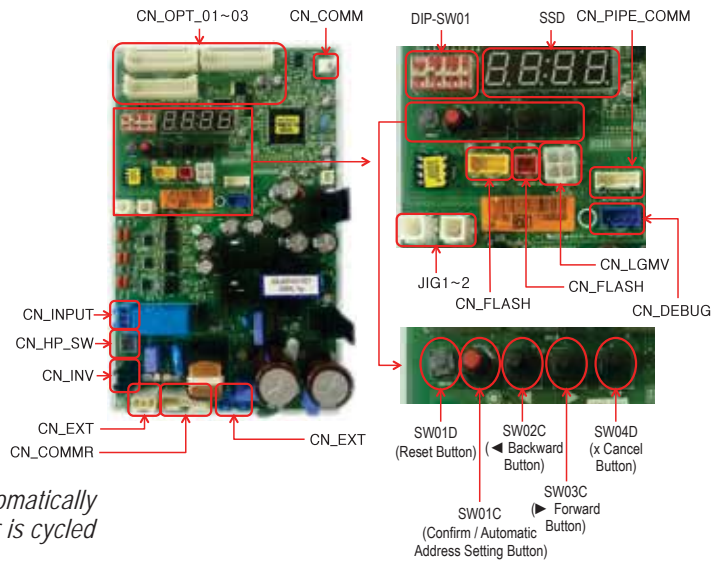

Table 19: Optional Modes.

Mode Selection		Selection		Selection		Notes
Content	Display	Mode / Function Name	Display	Default	Options	
Fault Detection and Diagnostics	Fdd	Refrigerant Auto Charge (Cooling)	Fd1		-	
		Refrigerant Auto Charge (Heating)	Fd2		-	
		Refrigerant Auto Judge (Cooling)	Fd3		-	
		Refrigerant Auto Judge (Heating)	Fd4		-	
		Integrated Test Run	Fd7	-	-	
		All Indoor Unit Cooling Operation	Fd8, cooL	oFF	oFF, on	
		All Indoor Unit Heating Operation	Fd9, hEAt	oFF	oFF, on	
Function	Func	Cool / Heat Selector Switch (Installed)	Fn1	oFF	oFF, oP1~oP2	Saved in EEPROM; Off = Not Installed
		Static Pressure Compensation	Fn2	oFF	oFF, oP1~oP3	Saved in EEPROM; Used for ducted discharge.
		Night Low Sound	Fn3	oP10	oP1~oP12	Saved in EEPROM.
		Overall Defrost	Fn4	oFF	on, oFF	Saved in EEPROM. Off = Split Coil / Frame Allowed
		Outdoor Unit Addressing	Fn5	0	0~254	Saved in EEPROM.
		Snow Removal Assist / Rapid Defrost	Fn6	oFF	oFF, oP1~oP3	Saved in EEPROM.
		Adjusting Indoor Unit Capacity	Fn7	oFF	oFF, oP1~oP2	Saved in EEPROM.
		Adjusting Target Pressure	Fn8	oFF	oFF, oP1~oP6	Saved in EEPROM.
		Low Ambient Kit	Fn9	oFF	on, oFF	Saved in EEPROM.
		High Efficiency Mode (Cooling Operation)	Fn10	oFF	on, oFF	Saved in EEPROM.
		High Efficiency Mode Cooling Operation (Auto Dust Throw)	Fn11	oFF	oFF, oP1~oP5	Saved in EEPROM.
		Smart Load Control	Fn14	oFF	oFF, oP1~oP3	Saved in EEPROM; Can use in all applications except DOAS. Energy saving feature.

Table 20: Optional Modes, continued.

Mode Selection		Selection		Selection		Notes
Content	Display	Mode / Function Name	Display	Default	Options	
Function	Func	Humidity Reference	Fn16	oFF	on, oFF	Saved in EEPROM.
		Power Consumption Display on Wired Remote Controllers	Fn21	oFF	oFF, Pd10, Pd11	Saved in EEPROM.
		Overall Defrost Operating in Low Temperature (Heating)	Fn22	oFF	on, oFF	Saved in EEPROM.
		Drain Pan Heater (Optional Accessory)	Fn23	oFF	on, oFF	Saved in EEPROM.
User	Idu	Comfort Cooling	Id10	EAch	-	Saved in EEPROM
Service	SvC	Pump Down	SE1, Pd	Pd	-	
		Pump Out	SE2, Po	Po	-	
		Vacuum Mode	SE3, vAcc	vAcc	-	One Time / One Selection
		Manual Backup for Inverter Compressor	SE4	oFF	oFF, inv1, inv2, unit backup	Saved in EEPROM.
		Forced Oil Return	SE5, 01	oFF	on, oFF	
		Forced Defrost	SE6, dEF	oFF	on, oFF	
		Cycle Data View	SE8	oFF	on, oFF, oP1~oP26	Shows each cycle value in real time.
		Refrigerant Sound Reduction Mode	SE9	oFF	on, oFF, oP1~oP2	Saved in EEPROM.
		Heating Fan Low Sound	SE11	oFF	on, oFF	
		Number of Partial Defrosts	SE12	oFF	oP1~oP11	
Level Change of Error Code CH200	SE14	oFF	on, oFF			

## Setting Optional Modes

### Emergency Operation

If an inverter compressor is not operating, the system can still operate (except the defective compressor) by using one of two methods.

#### Automatic Emergency Operation (Automatic Backup Function)

If an outdoor unit detects an inverter compressor error during operation, the automatic backup mode is initiated.

1. Inverter 1 compressor automatic emergency operation.
2. Inverter 2 compressor automatic emergency operation.

#### Manual Emergency Operation (Manual Backup Function)

1. Verify which compressor is malfunctioning (refer to the Troubleshooting section in the back of this manual).
2. Turn off the power.
3. Set the DIP switch of the defective outdoor unit following the instructions below.
4. Turn on the power.

#### If Slave 1 Outdoor Unit Inverter Compressor Fails

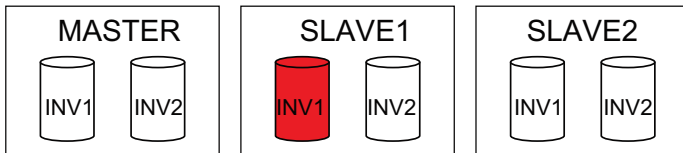

1. Ensure Slave 1 Outdoor Unit PCB No. 5 DIP Switch on DIP-SW01 DIP switch bank is set to ON.
2. Select the "SVC" Mode by using the SW03C forward ► and SW02C backward ◀ buttons, then push the SW01C confirm ● button.
3. Select the "Se4" function by using the SW03C forward ► and SW02C backward ◀ buttons, then push the SW01C confirm ● button.
4. Select the "inv1" Option by using the SW03C forward ► and SW02C backward ◀ buttons, then push the SW01C confirm ● button.
5. Select "Action" "on" by using the SW03C forward ► and SW02C backward ◀ buttons, then push the SW01C confirm ● button.

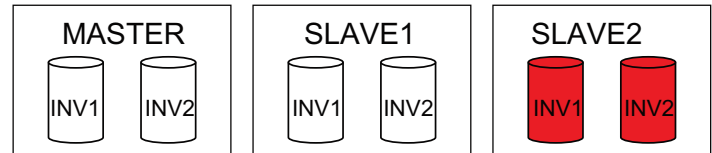

#### If Slave 2 Outdoor Unit Fails

1. Ensure Slave 2 Outdoor Unit PCB No. 5 DIP Switch on DIP-SW01 DIP switch bank is set to ON.
2. Select the "SVC" Mode by using the SW03C forward ► and SW02C backward ◀ buttons, then push the SW01C confirm ● button.
3. Select the "Se4" Function by using the SW03C forward ► and SW02C backward ◀ buttons, then push the SW01C confirm ● button.
4. Select the Option "unit" by using the SW03C forward ► and SW02C backward ◀ buttons, then push the SW01C confirm ● button.
5. Select "Action" "on" by using the SW03C forward ► and SW02C backward ◀ buttons, then push the SW01C confirm ● button.

#### Backup Mode Cancellation

Select the "Action" "off" by using the SW03C forward ► and SW02C backward ◀ buttons, then push the SW01C confirm ● button.

#### Note:

- ⚠ Do not run the system under emergency operation with an inverter compressor failure for more than 48 hours. It will cause compressor failure within the other outdoor units.
- During the emergency operation, cooling / heating capacity will be reduced.

**Fault Detection Diagnosis (FDD) Checklist**

1. A test run must be performed before running the automatic address procedure. After installation, recheck the auto addressing.
2. To start at one point after three (3) minutes when the initial power is turned on for the test run: After power is turned on, the MICOM data is reset, and communications with the indoor units will start within three (3) minutes.
3. Indoor units must be series seven (7) and higher.
4. For the FDD test run, the results and errors of the test run are displayed only on the Master outdoor unit Main PCB SSD.
5. If the error occurred during the test run, the system will operate following the last step after the test run is turned off. Change the DIP switch to OFF, and then press and hold the SW01D reset button for two (2) seconds to reset all data and return to operation standby.
6. To reset the system if the test run must be shut off because of an error, press the SW04C (X: Cancel) and SW01C (●: execute) button simultaneously for more than five (5) seconds.
7. All indoor units are turned off, or the results are displayed for ninety (90) seconds after the test run is finished.
8. If all FDD functions wish to be used, first press the main PCB SW01D reset button for three (3) minutes.
9. A normal test run operates if LGMV version 7.1.1 or later is used.

**Fault Detection Diagnosis (FDD) Codes**

Table 21: FDD Error Codes.

Error Codes	Display	Problem
E01	<b>E01</b>	Indoor unit combination capacity is >130% or <80% less than outdoor unit rated capacity.
E02	<b>E02</b>	System is unstable.
E03	<b>E03</b>	Temperature range error.
E04	<b>E04</b>	Can't operate FDD function for defrost.
E05	<b>E05</b>	Sensor check function error.
E06	<b>E06</b>	Only one indoor unit is present.
E07	<b>E07</b>	Button was not pressed for auto refrigerant charge function.
E08	<b>E08</b>	FDD was forced to terminate, or refrigerant auto charge terminated normally.
E09	<b>E09</b>	System off / wait to operate FDD function.
E10	<b>E10</b>	Need additional refrigerant.
System Error	Same as Normal Operation	System error has occurred

## Setting Optional Modes

### Refrigerant Auto Charge (Fd1 [Cooling], Fd2 [Heating])

This function can be used to automatically charge a suitable amount of refrigerant in the system through cycle operation. Use the refrigerant auto charge function if the refrigerant amount is not correct after the system is serviced, if there is a leak in the piping, etc. (During the installation procedure, make sure to calculate and add the proper amount of refrigerant.)

Refrigerant charging time can be different depending on the amount necessary. Approximate charge time is about 6.6 minutes per pound.

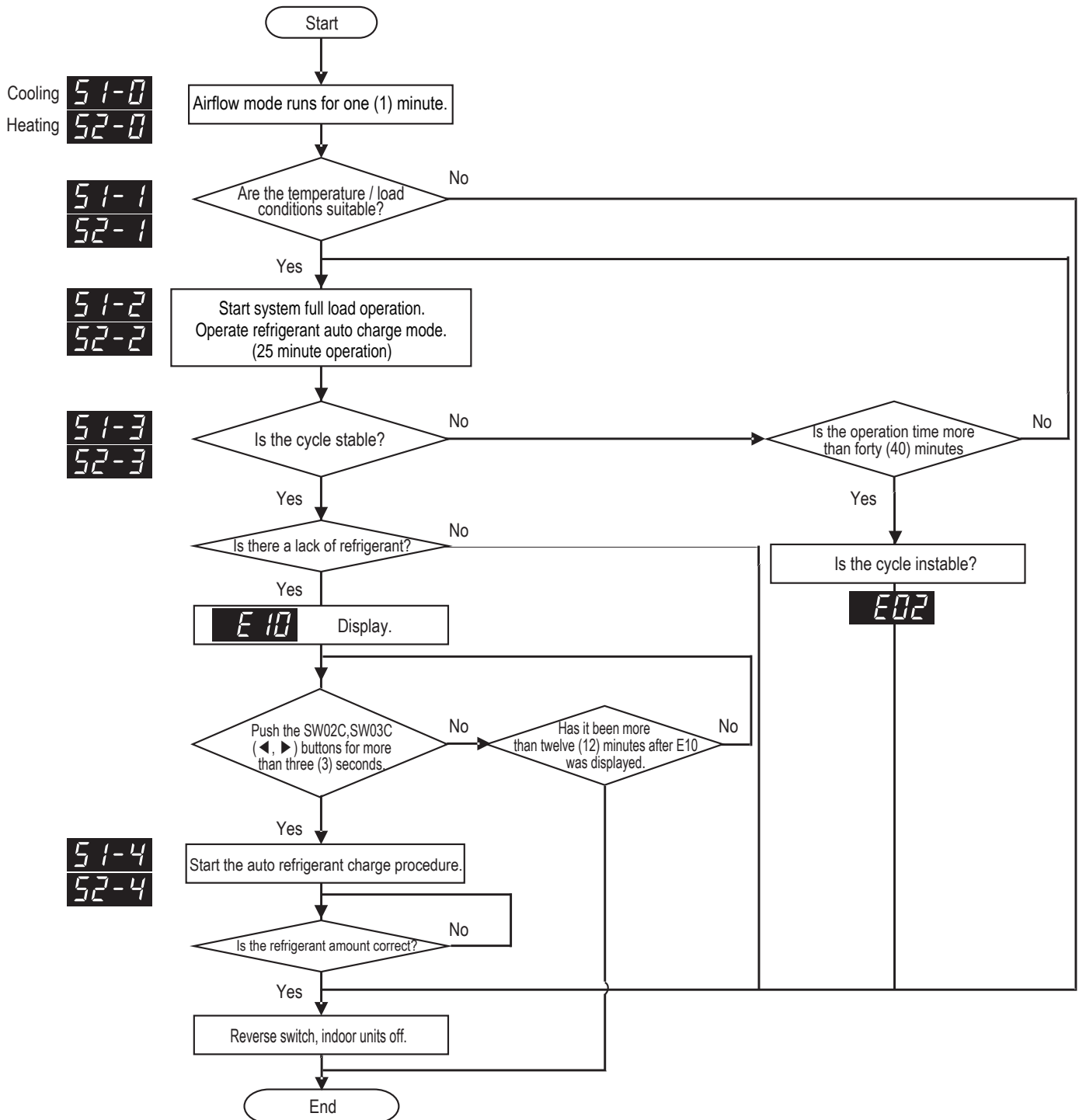

MULTI V 5 Outdoor Unit Service Manual

**Note:**

- Follow the procedures indicated when charging refrigerant.
- If ambient conditions are beyond the operating temperature range, Refrigerant Auto Charge will not function properly.
- Outdoor Unit Operating Temperature Range: Cooling = 32~109.4°F; Heating = 14~75.2°F.
- Indoor Unit Operating Temperature Range: Cooling = 32~64.4°F; Heating = 50~80.6°F.
- If the system continuously turns off because of excessive low pressure levels before "E10" is displayed, the system does not nearly have enough refrigerant. Add about 15% of the estimated refrigerant amount, and try the procedure again.
- Press the SW04C (X: Cancel) button and change the DIP switch to off after the auto refrigerant charge function ends.

**Refrigerant Charge Procedure**

1. Prepare manifold, refrigerant, and scale (sold separately).
2. Connect manifold to refrigerant charge port as shown.
3. Connect manifold and refrigerant cylinder.
4. Perform the air purge procedure for each manifold hose.
5. When **PrE5** / **PUTn** appear, push the SW03C forward ► or SW02C backward ◀ button.
6. When **51-4** or **52-4** appear, open the valve and add refrigerant to the system.
7. When **51-5** or **51-5** appear, close the valve and remove the connected charge port.

**⚠ WARNING**

When performing the leak test and air purge, use a vacuum pump or an inert gas such as nitrogen. If oxygen, compressed air, or flammable gas are used, there is a possibility of fire, explosion, personal injury, and death.

**Note:**

- When charging refrigerant, use the specified equipment.
- To reduce communication errors, use the wired remote control to set the main unit.
- During indoor unit operation, system must be in Thermo on, otherwise the procedure will not operate.
- If outdoor unit switched to defrost mode while the auto refrigerant charge function was operating, restart auto refrigerant charge function only after defrost mode is finished.

Figure 8: Refrigerant Charge Set Up.

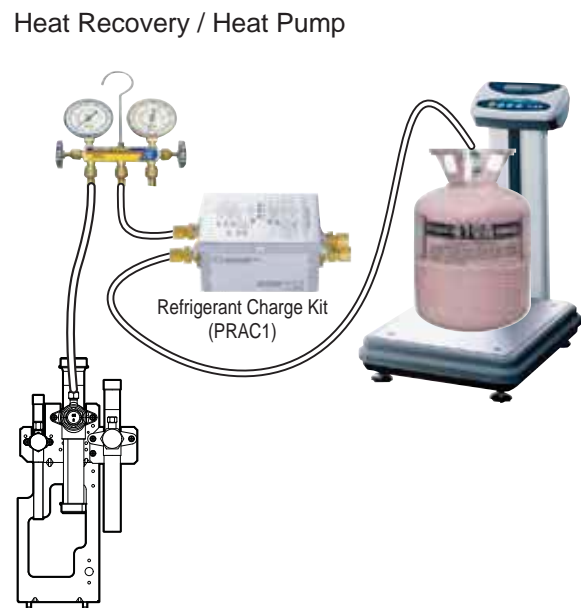

## Setting Optional Modes

### Refrigerant Auto Judge (Fd3 [Cooling], Fd4 [Heating])

This function allows the system to automatically judge refrigerant levels through system operation. Refrigerant Auto Judge can be used to see if the system has been overcharged or undercharged, and can be used with the Refrigerant Auto Charge function.

MULTI V 5 Outdoor Unit Service Manual

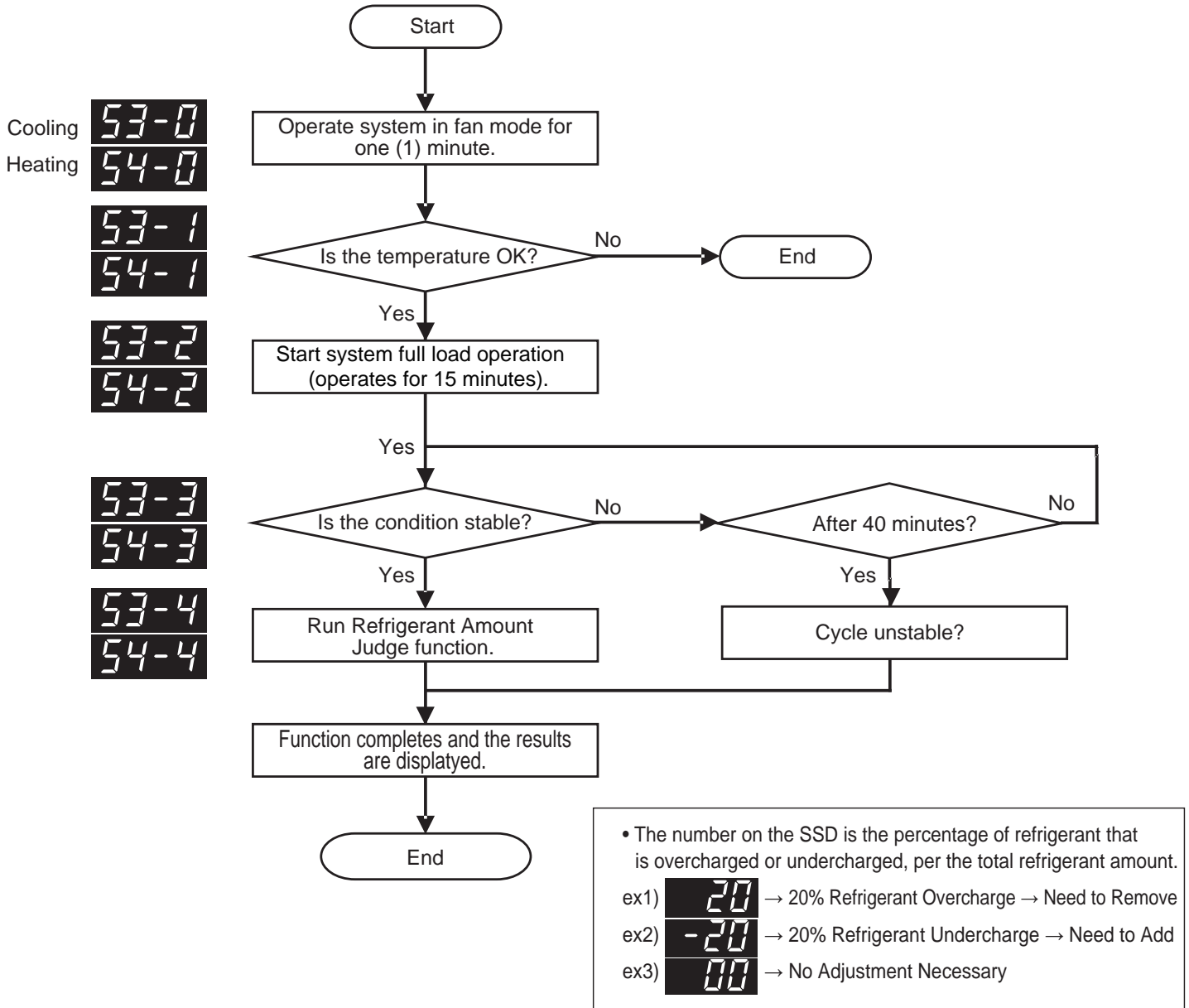

Refrigerant Amount Auto Measure function will not work or stop if the indoor unit combination ratio and the operating temperature range are not within manufacturer's allowable parameters.

- Indoor unit combination ratio: 80~130%
- Outdoor unit operating temperature range: Cooling = 32~109.4°F; Heating = 14~75.2°F.

Refrigerant Auto Judge runs for fifteen (15) minutes at full load operation; refrigerant levels can be measured directly under special cases.

- Press SW04C (X: Cancel) button, and turn No. 5 on the master outdoor unit PCB DIP switch bank SW01 to OFF after the function ends.

### Integrated Test Run (ITR) (Fd7)

The algorithm tests the operation of all components and system functions. Using a batch file concept, the routine begins by asking the technician to enter the total refrigerant charge in kilograms.

#### Note:

Unlike previous versions of Multi V where the user selected heating or cooling mode for the Integrated Test Run function, Multi V 5 automatically selects which mode to use based on outside air temperature.

#### Procedure

1. Connect a computer with LGMV software to the Master ODU.
2. Start the LGMV software.
3. Select ID7 on the Master outdoor unit seven segment display (SSD).
4. "INIT ITR" will be displayed (Initiate Integrated Test Run)
5. Use the SSD and the control buttons below it to enter the system refrigerant charge by weight in kilograms. The system refrigerant charge is the sum of the field provided refrigerant charge and the factory refrigerant charge shipped with each outdoor unit.

#### Note:

See the specification tables in the Product Data section for the factory refrigerant charge in pounds.

#### Example:

ARUM432BTE5

- Consisting of (2) ARUM121BTE5 + (1) ARUM192BTE5
- Factory charge ARUM121BTE5 = 23.2 lbs each
- Factory charge ARUM192BTE5 = 30.9 lbs
- Field trim charge : 10.5 lbs

System refrigerant charge = (Factory charge of frame 1 + Frame 2 + Frame 3)+(Field-supplied Refrigerant)

System refrigerant charge = (23.2 + 23.2 + 30.9) + 10.5 = 87.8 lbs.

To convert the refrigerant charge from pounds to kilograms:

Kilograms refrigerant = pounds refrigerant x 0.453592

Kilograms refrigerant = 87.8 x 0.453592  
= 3.983 kilograms

6. Press the confirm/accept button on the ODU under the SSD.
7. Observe the SSD displays "88" to confirm the ITR is running. The ITR will run for approximately 5 to 30 minutes. When "88" is no longer displayed, the ITR has successfully completed.
8. If more than 30 minutes pass and "88" is still displayed, the ITR has failed. Contact your LG representative for technical assistance.
9. After a successful ITR, you can go to the LGMV Diagnostics tab, select Test Report, and save the .html data file. The report on the next page is a sample ITR report.

#### Note:

If an error occurs with an indoor unit, operate that indoor unit in fan mode, but make sure the auto address number of that indoor unit does not display.

### Multi V ITR Result Report

Follow the Procedure:



Save html file

# OTHER CONTROLS

## Setting Optional Modes

### Multi V ITR Result Report, Continued.

Start up Confirmation														
Model type	Multi V 5 HR			Model Name	model na			The date of print	May 23, 2017 5:35:47 AM					
Installation Information														
	Name			Company Name & Address					Product					
Installation									ODU	1 EA (1.8.0)				
CIQ									IDU	4 EA				
Supervisor									HRU	1 EA				
Site									Total refrigerant	10.5 Kg				
*Please check the installation information with the actual products.														
ITR Conditions														
	Air Temperature			Standard					Status of ITR					
Indoor	74.1 °F			Cooling: 50.0°F ≤ Indoor air ≤ 95.0°F Heating: 41.0°F ≤ Indoor air ≤ 89.6°F					Operating Mode	ITR(Cooling)				
Outdoor	72.3 °F			Cooling: 23.0°F ≤ Outdoor air ≤ 113.0°F Heating: 5.0°F ≤ Outdoor air ≤ 95.0°F					ITR Error Information	-				
ITR Result														
Refrigerant					ODU EEV					IDU EEV				
CompletedRefrigerant : -3.1kg					-					Okay				
*Each Result is affected by the results of other items. After modifying the problem , please recheck.														
Cycle Summary														
Item	ODU1				ODU2				ODU3				Criterion For Judgment	
	Minimum	Maximum	Average	Judgment	Minimum	Maximum	Average	Judgment	Minimum	Maximum	Average	Judgment		
High Pressure (kPa)	2729	2729	2729		0	0	0		0	0	0		2000~3500kPa (Cool/Heat)	
Low Pressure (kPa)	1092	1092	1092		0	0	0		0	0	0		650~1200kPa (Cool) 200~1000kPa (Heat)	
ODU EEV pulse	32	32	32		0	0	0		0	0	0		-	
Discharge SH (°F)	-	-	40.3		-	-	0.0		-	-	0.0		18.0~90.0°F	
Suction SH (°F)	-	-	11.7		-	-	0.0		-	-	0.0		0.9~54.0°F	
Subcool (°F)	-	-	5.9		-	-	0.0		-	-	0.0		0.9~36.0°F	
INV1 Discharge (°F)	-	-	158.0		-	-	572.0		-	-	572.0		122.0~212.0°F	
INV2 Discharge (°F)	-	-	572.0		-	-	572.0		-	-	572.0		122.0~212.0°F	
Input Voltage (V)	205	205	205		0	0	0		0	0	0		345~456V	
Input Current (A)	10.2	10.2	10.2		0	0	0		0	0	0		20A↓	
INV1 phase Current (A)	-	-	29.6		-	-	0		-	-	0		24A↓	
INV2 phase Current (A)	-	-	0		-	-	0		-	-	0		24A↓	
*Criterion for judgment stands for the boundaries to decide error condition for normal operating conditons. Therefore, even if it display error signal, it is recommended to re-confirm the results based on the physical behavior of air-conditioning and refrigeration system.														

**All Indoor Unit Cooling Operation (Fd8) or All Indoor Unit Heating Operating (Fd9)**

Fault Detection and Diagnosis (FDD [Fd]) modes are part of LG’s on board service algorithms that provide system operation insight when LGMV software is not used. To record or save any data, LGMV or a recording saving data module must be installed. Fd codes can also be used for commissioning, or to troubleshoot a problem on an existing system. The results provided by running an Fd mode must not be considered definitive proof that a system is properly operating. Fd code must not be left on without an LG trained service provider approving and guiding its use.

Both the All Indoor Unit Cooling (Fd8) and All Indoor Unit Heating (Fd9) modes force the entire system (outdoor units and indoor units) to operate in full blast cooling or full blast heating. Room temperatures and setpoints are ignored. Use these modes for commissioning to provide an hour of data a start up, and / or to test operation in seasons opposite of when the system is installed (i.e., if the system is installed in the summer, set it to Fd9 to test how the system would operate in heating during the winter months).

**Note:**

*The All Indoor Unit Cooling or All Indoor Heating function, as well as other FDD algorithm could take up to forty (40) minutes to complete, depending on the number of indoor units connected to the system.*

Table 22: All Indoor Unit Cooling or All Indoor Unit Heating Function Settings.

Function	Code	Default	Setting
All Indoor Unit Cooling Operation	Fd8, cool	oFF	on
All Indoor Unit Heating Operation	Fd9, hEAt	oFF	on

Figure 9: Setting the All Indoor Unit Cooling (Fd8) or All Indoor Unit Heating (Fd9) Function.

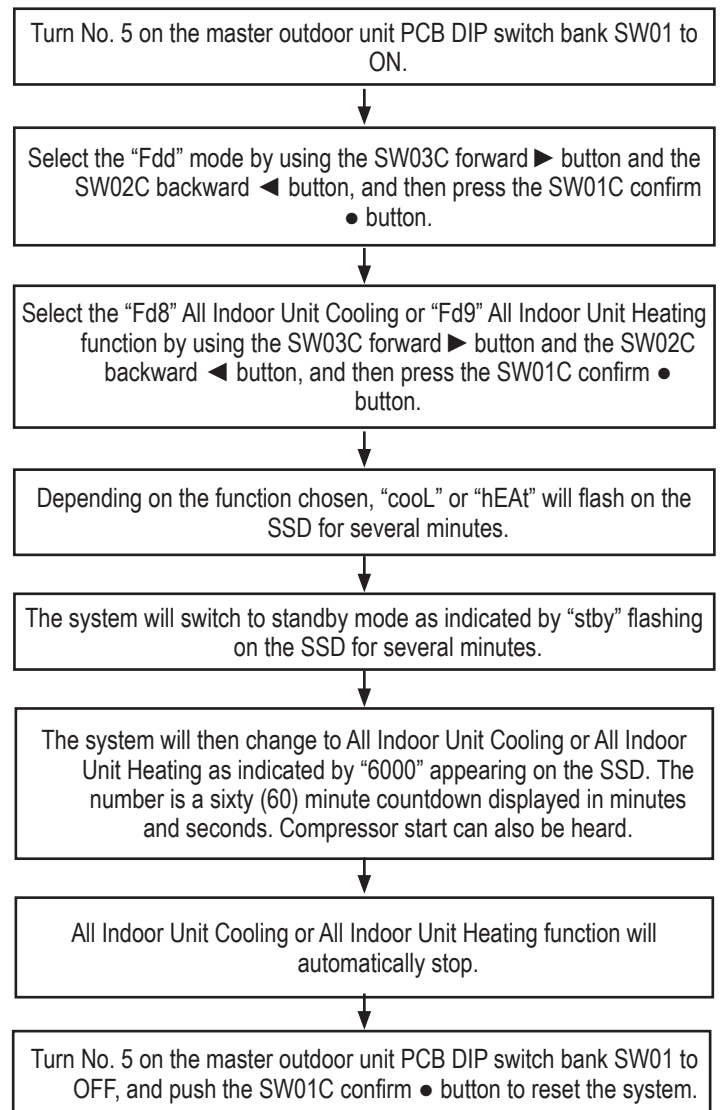

Outdoor Unit Functions

## Setting Optional Modes

### Cool / Heat Selector (Fn1)

The setting communicates to the outdoor unit that the optional LG Cool / Heat Selector (or appropriate field-provided relays and wiring that perform the same task) is connected to the system. The Cool / Heat Selector is field-wired to the "Dry 1" and "Dry 2" terminals located on the master outdoor unit main PCB.

The Cool / Heat Selector has two switches. The two-position upper switch manually locks out heating and cooling operation, allowing fan only, or heating or cooling operation depending on the position of the lower switch. The two-position bottom switch manually sets the position of the outdoor unit's reversing valve. If the left side is depressed, the valve is in the cooling position. If the right side is depressed, the valve is in the heating position. The Cool / Heat Selector also provides a method for locking out compressor operation by placing the "Fan Only" toggle switch in the "On" position.

- Off (Default): No Cool / Heat Selector installed, or the Cool / Heat Selector is installed, but has not been identified by the master outdoor unit.
- On: Cool / Heat Selector installed and operational. When On is selected:
  - The left side of the upper switch is depressed. Mechanical refrigeration is locked out and the indoor unit fans are allowed to operate. The position of the lower switch is irrelevant.
  - The right side of the upper switch is depressed, the lower switch has the right side depressed, and the system is operating in cooling.
  - The right side of the upper switch is depressed, the lower switch has the left side depressed, and the system is operating in heating.

Use the Cool / Heat Selector in heat pump systems to set the system mode for all cooling operation, all heating operation, fan only, or dry operation (when all indoor units have to be in the same mode).

For use in heat pump systems only.

Figure 11: Setting the Cool / Heat Selector Function.

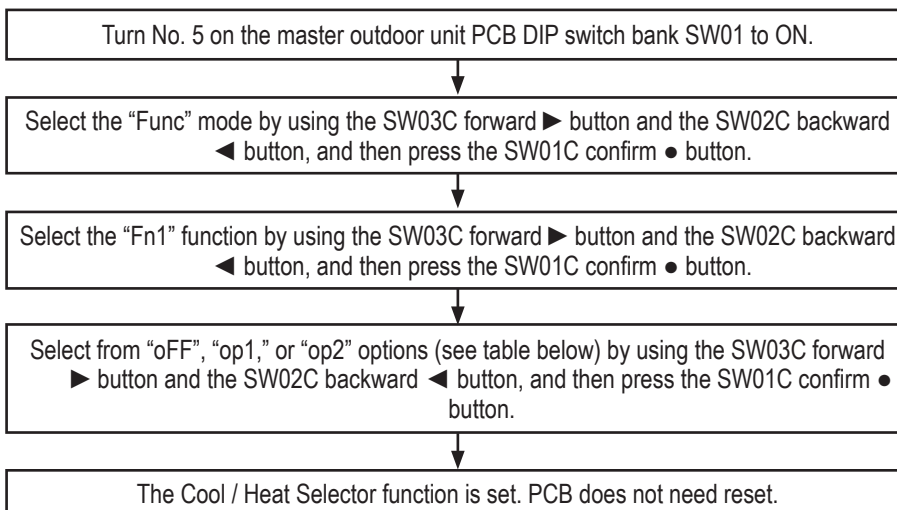
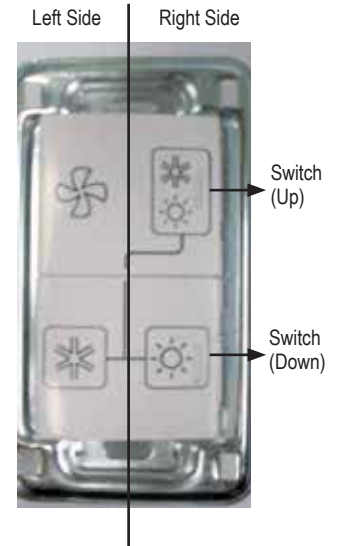

Table 23: Cool / Heat Selector Function Settings.

Switch Control		Function		
Switch (Up)	Switch (Down)	oFF	op1 (Mode)	op2 (Mode)
Right Side (On)	Left Side (On)	Not Operating	Cooling	Cooling
Right Side (On)	Right Side (On)	Not Operating	Heating	Heating
Left Side (Off)	-	Not Operating	Fan Mode	Off

Figure 10: Cool / Heat Selector.



### Note:

- The Cool / Heat Selector must be installed first before setting the cool / heat operation function.
- A trained LG service provider must set this function during system installation.
- If cool or heat function is not used, set to OFF.
- Cool / Heat Selector is flagged as the master on the central control communications bus.
- Cool / Heat Selector is not for use with BMS Gateway, VMS, or VMS Communications Manager.

**Static Pressure Compensation Function (Fn2)**

Static Pressure Compensation function modifies the maximum outdoor unit fan speed during normal system operation. Use the function to raise the maximum outdoor unit fan speed to compensate for an obstruction (duct) in airflow.

The default outdoor fan external static pressure rating for Multi V 5 Outdoor Units is 0.16 in-wg. Selecting “op3” raises the fan speed to produce the same airflow at 0.32 in-wg.

Refer to the Multi V Engineering Manuals for the default static pressure rating, and the maximum static pressure rating with this function engaged.

For use on both heat pump and heat recovery systems.

**Note:**

- Ask a trained LG service provider to set this function during system installation.
- If the outdoor unit RPM is changed, cooling capacity could be reduced.

Figure 12: Setting the Static Pressure Compensation Function.

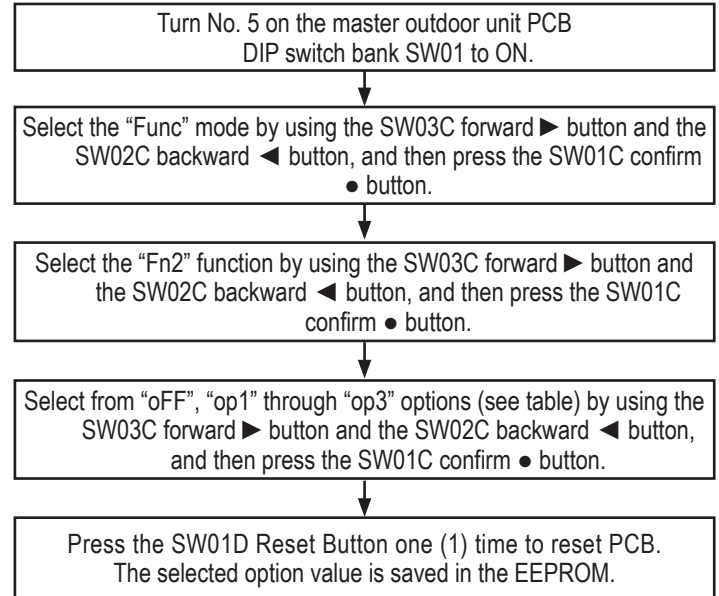

Table 24: Setting Static Pressure Compensation Function.

Settings	Nominal 6 Ton (RPM)	ESP (in-wg)	Nominal 8 to 20 Ton (RPM)	ESP (in-wg)
oFF (Default)	730	0.16	950	0.16
op1	760	0.23	1,020	0.23
op2	780	0.27	1,050	0.27
op3	880	0.32	1,130	0.32

## Setting Optional Modes

### Night Low Sound Function (Fn3)

The Night Low Sound Function reduces the operating speed of the outdoor unit fans (according to the input signal) during “off-peak” hours under normal circumstances when in cooling mode. Operating at a low RPM reduces the fan sound levels of the outdoor unit at night (or other off-peak hours), which usually has a low cooling load.

On a rolling 24 hour basis, an internal timer begins counting hours after the start time (delay set after peak cooling recorded operation), switching to restricted fan speed duration operation, following whatever settings have been chosen.

For use on both heat pump and heat recovery systems.

- Oil return is considered an abnormal condition.
- Timed algorithm. Restricted fan speed period length and start delay is selectable.
- Delay timer starts each day when, during a one (1) minute period the highest demand for cooling is recorded by the outdoor unit.

Figure 13: Setting the Night Low Sound Function.

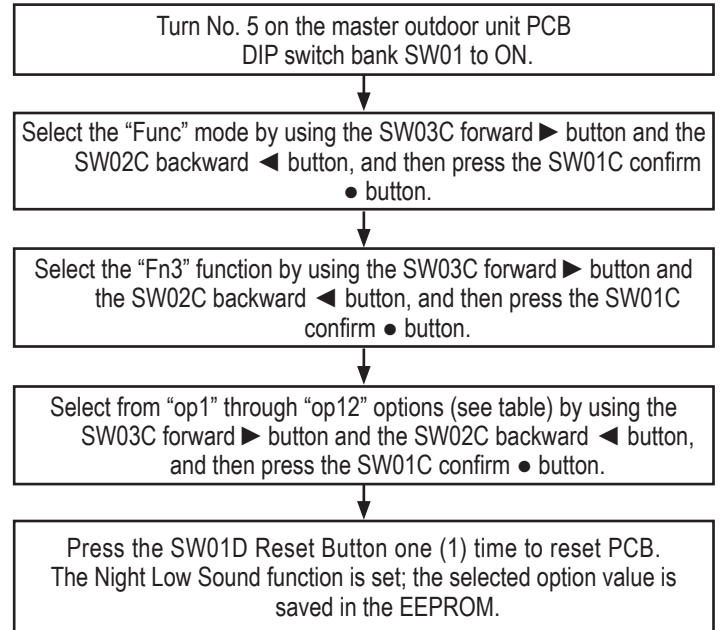

Table 25: Setting the Time and Related Sound Level.

Settings	Start Time (Delay after Peak Cooling Recorded) (Hour)*	Restricted Fan Speed Duration (Hour)	Approximate Noise Level dB(A)	
			6 Ton	8 to 20 Ton
op1	8.0	9.0	55	59
op2	6.5	10.5	55	59
op3	5.0	12.0	55	59
op4	8.0	9.0	52	56
op5	6.5	10.5	52	56
op6	5.0	12.0	52	56
op7	8.0	9.0	49	53
op8	6.5	10.5	49	53
op9	5.0	12.0	49	53
op10 (Default)	0.0 (Continuous Operation)	24.0	55	59
op11	0.0 (Continuous Operation)	24.0	52	56
op12	0.0 (Continuous Operation)	24.0	49	53

\*The system measures ambient temperature (minimum and maximum) in “Wait Time” to help determine when the system can start operating in Night Low Sound.

**(Overall) Defrost Function (Fn4)**

Overall Defrost Function allows the outdoor unit to operate in either full frame / full coil (overall) defrost or in full system defrost. When selected, the Intelligent Defrost algorithm can no longer choose split-coil or partial frame (in multi-frame systems) defrost. System pressure, outdoor unit coil temperatures, and outdoor ambient temperatures (and humidity if Fn16 - Humidity Reference) will determine when the defrost cycle initiates.

Use in locations where relative humidity remains high during the heating season, or in applications where it has been proven that operating all of the outdoor units in defrost at the same time saves energy, and / or shortens the defrost time without impacting comfort levels.

Can also be used with Fn6 - Rapid Defrost, SE6 - Forced Defrost, Fn22 - Overall Defrost Operating in Low Temperatures (Heating), and Fn16 - Humidity Reference.

For use on both heat pump and heat recovery systems.

Table 26: Setting the Overall Defrost Function.

Options	Function
oFF (Default)	System Operates in Partial-Coil Defrost (or Partial Frame Defrost in Multi-Frame Systems)
on	System Operates in Full Frame (Overall) Defrost Only

**Outdoor Unit Addressing Function (Fn5)**

Use this function to set addresses when more than one Multi V system shares a communications bus linked to a central controller or BMS gateway. Each system is assigned to a unique outdoor unit address. The Outdoor Unit Addressing Function will help avoid assigning the same address to the different systems; if not properly addressed, a communication error could occur on one (1) or more of the systems.

For use on both heat pump and heat recovery systems.

- 000 = Default; Central Control Address setting of "000".
- 001 = Central Control Address setting of "001".
- Set 1 of 255 Valid Addresses; 000, 001, 002, 003, 004...through 254.

**Note:**

- The central controller or BMS gateway must be installed first before setting the outdoor unit address.
- A trained LG service provider must set this function during system installation.

Figure 14: Setting the Overall Function.

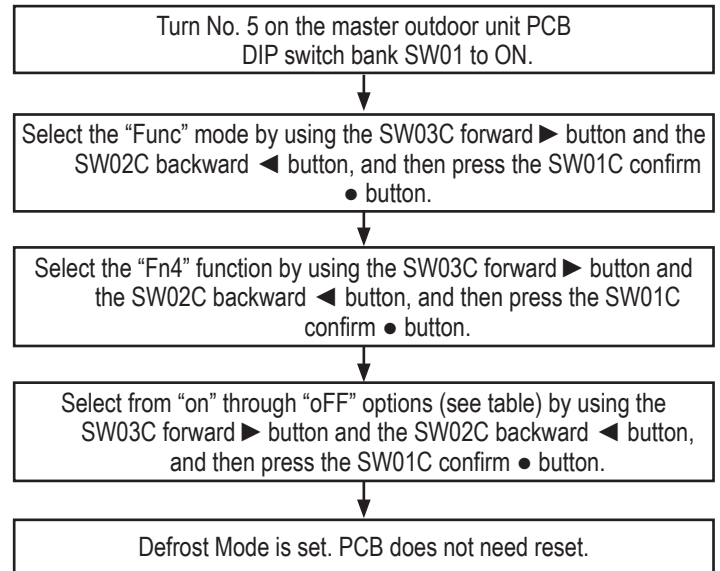

**Note:**

A trained LG service provider must set this function during system installation.

Figure 15: Setting the Outdoor Unit Address Function.

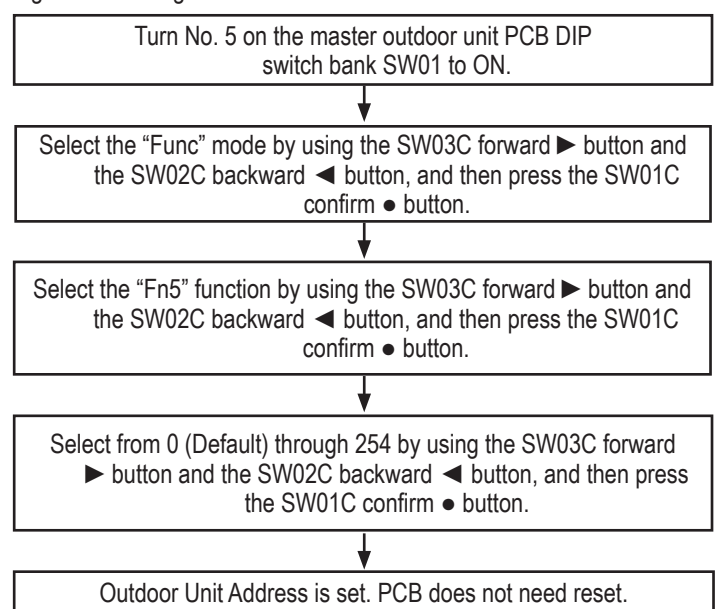

## Setting Optional Modes

### Snow Removal Assist / Rapid Defrost Function (Fn6)

#### Snow Removal Assist

Snow Removal Assist function allows the outdoor unit(s) fans to operate at regular intervals, for two (2) minutes, at specified speeds (as seen in the tables below) to remove snow accumulation from the fan discharge.

The function will only operate when the system has not called for compressor activity (no demand for heating or cooling) for thirty (30) minutes, and when the outdoor air temperature is <37°F. Operates every thirty (30) minutes for two (2) minutes. Function will stop if there is an operation error code, or if a compressor starts. Use this function in areas where snow accumulating on the fan blades and fan guard is common.

#### Rapid Defrost

Rapid Defrost function limits the amount of frost and ice are allowed to build on the coil between defrost cycles (defrost cycles occur more often). System pressure is monitored, and when system pressure is reduced, the defrost cycle is initiated.

Snow Removal Assist / Rapid Defrost can also be used with Fn4 - Overall Defrost, and Fn22 - Overall Defrost Operating in Low Temperatures (Heating).

Snow Removal Assist and Rapid Defrost can be used on both heat pump and heat recovery systems.

Table 27: Setting the Snow Removal / Rapid Defrost Function.

Settings	Details	Fan Speed During Snow Removal Assist (RPM)	
		6 Ton	8 to 20 Ton
oFF (Default)	Mode Is Not Set	-	-
op1	Snow Removal Assist Mode	670	850
op2	Rapid Defrost Mode	-	-
op3	Snow Removal Assist Mode and Rapid Defrost Mode	670	850

Figure 16: Setting the Snow Removal / Rapid Defrost Function.

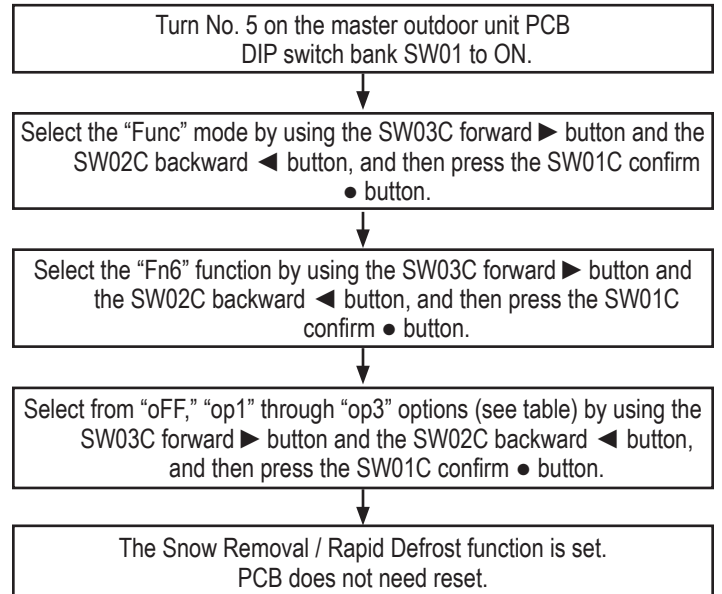

#### Note:

- A trained LG service provider must set this function during system installation.
- If the snow removal / rapid defrost mode is not used, set to OFF.

### Adjusting Indoor Unit Capacity (Fn7)

The Adjusting Indoor Unit Capacity function limits the maximum fan speed on all indoor units to the “low” speed setting. Use the function when it is known that the outdoor unit is operating at full capacity during the heating season and the indoor unit air temperature in all zones is low, or when it feels drafty in almost all of the conditioned zones served by the system. The function can be used to lower or raise the indoor unit leaving air temperatures, when the outdoor unit is undersized, or the system is operating with a compressor out of service. If this function is turned on, the indoor unit heating capacity will be sacrificed to achieve a higher leaving air temperature.

For use on both heat pump and heat recovery systems.

**Note:**

- The Adjusting Indoor Unit Capacity Fn7 function is not a solution for a poorly designed piping system, nor is it a solution for a system that is not operating properly.
- Verify the system’s refrigerant charge is correct before using this function.

### Adjusting Target Pressure (Fn8)

The Adjusting Target Pressure function modifies the refrigeration cycle’s high and low pressure target values; more specifically, modifies the compressor discharge and suction target operating pressure values. Can be used to enhance / turn down the cooling or heating capabilities of variable refrigerant flow systems, optimizing refrigeration cycle operation to maximize operational efficiency.

Separate, unique setting values can be assigned for cooling, heating operation, and Hydro Kit operation.

If the outdoor unit is dedicated to Hydro Kit(s), or an indoor unit combination includes a Hydro Kit in thermal on, see the right hand column in the table below for the high pressure vapor target psig.

An indoor unit combination with the Hydro Kit in thermal off, see the middle column in the table below for the high pressure vapor target psig.

For use on both heat pump and heat recovery systems.

Table 29: Setting Adjusting Target Pressure Function.

Setting	Low Pressure Vapor Target psig / kPa (°F)	High Pressure Vapor Target psig / kPa (°F)	
		IDUs (Hydro Kit Thermal Off)	IDUs (Hydro Kit Thermal On)
oFF (Default)	117 / 804 (39.5)	434 / 2,990 (122.8)	434 / 2,990 (122.8)
oP1	105 / 725 (34.0)	453 / 3,121 (126.1)	467 / 3,219 (128.7)
oP2	111 / 765 (37.0)	443 / 3,056 (124.5)	453 / 3,121 (126.1)
oP3	126 / 869 (43.5)	410 / 2,827 (118.5)	443 / 3,056 (124.5)
oP4	136 / 935 (47.5)	386 / 2,663 (114.1)	410 / 2,827 (118.5)
oP5	145 / 1,000 (51.0)	363 / 2,500 (109.5)	386 / 2,663 (114.1)
oP6	154 / 1,065 (54.3)	339 / 2,337 (104.8)	363 / 2,500 (109.5)
oP7	117 / 804 (39.5)	434 / 2,990 (122.8)	334 / 2,304 (103.6)

Figure 17: Setting the Adjusting Indoor Unit Capacity Function.

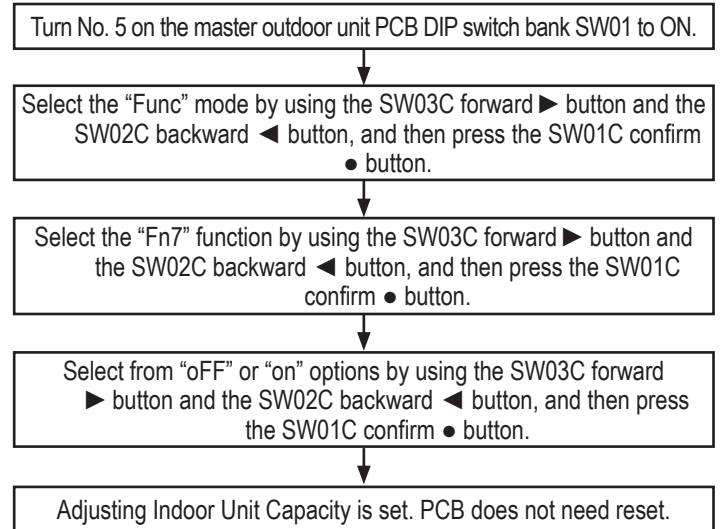
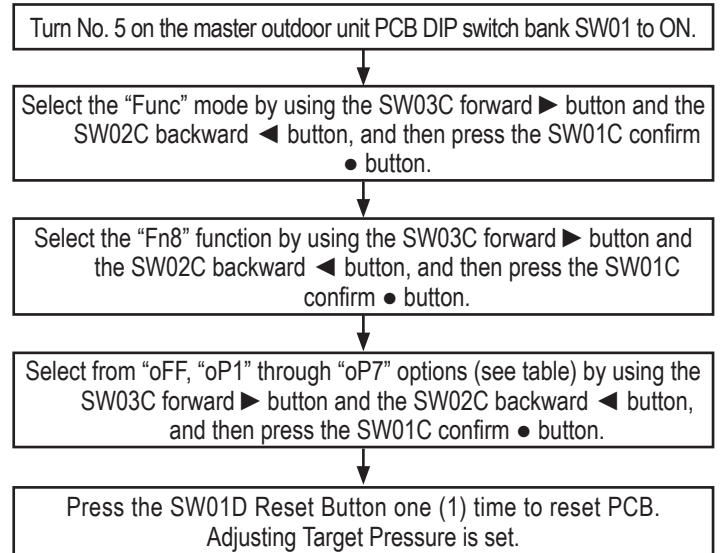

Table 28: Setting Adjusting Indoor Unit Capacity Function.

Options	Function
oFF (Default)	Disabled
on	Function Selected; Enabled

Figure 18: Adjusting Target Pressure Function.



# OTHER CONTROLS

## Setting Optional Modes

### Low Ambient Kit Function (Fn9)

The function notifies the outdoor unit that a low ambient kit is installed. Use in zones that will need cooling when outdoor ambient temperatures fall below 5°F.

Optional low ambient baffle kits allow for Multi V 5 outdoor unit operation down to -9.9°F. When used with heat recovery operation, low ambient cooling to -9.9°F is possible only when all indoor units are operating in cooling mode. Also when used with heat recovery systems, if one (1) or more indoor units are in heating, minimum cooling cycle ambient temperature is 14°F (low ambient wind baffle kit does not impact synchronous operating range).

For use on both heat pump and heat recovery systems.

**Note:**

See the Low Ambient Kit Installation Manual on [www.lghvac.com](http://www.lghvac.com) for installation, etc., information.

Table 31: Setting the Low Ambient Kit Function.

Settings	Function
oFF (Default)	Low Ambient Kit is Not Installed
on	Low Ambient Kit is Installed

### High Efficiency Function (Cooling Operation) (Fn10)

High Efficiency Function (Cooling Operation) increases compressor capability so the system can cool at high ambient temperatures. It automatically reduces the target low pressure as the outdoor ambient temperatures rises.

The function increases compressor operation, so net energy use will also rise.

Use for cooling-dominant installations, and on both heat pump and heat recovery systems.

**Note:**

Always verify the refrigerant charge is correct before using this function.

Table 30: Setting the High Efficiency Function (Cooling Operation).

Settings	Function
oFF (Default)	High Efficiency Function (Cooling Operation) Is Not Selected
on	High Efficiency Function (Cooling Operation) Selected

Figure 20: Setting the Low Ambient Kit Function.

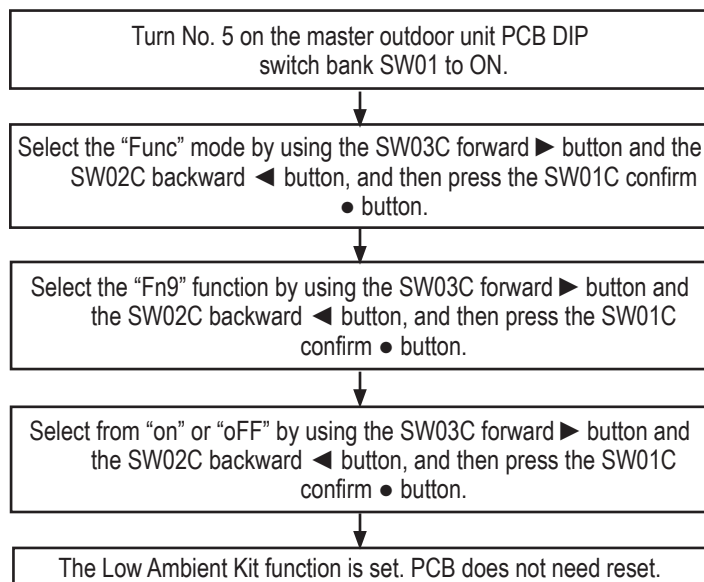
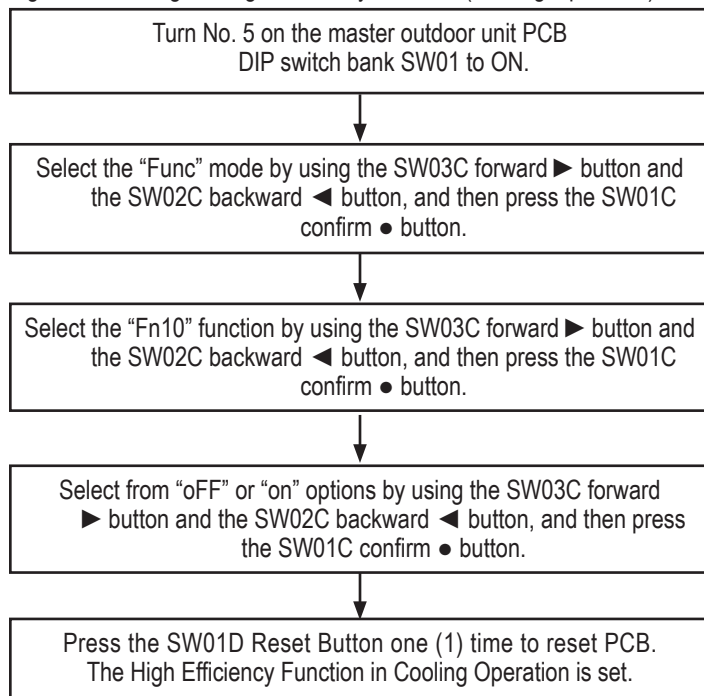

Figure 19: Setting the High Efficiency Function (Cooling Operation).



**High Efficiency Function Operation (Auto Dust Throw Mode) (Fn11)**

High Efficiency Function (Auto Dust Throw Mode) helps remove dirt / sand / debris that could have collected on the outdoor unit coil surface. After the cooling, heating, etc., mode is satisfied and the compressors are idle, this function will start the fan motors, operating them at full speed and in the reverse direction for a certain period. Air is drawn in through the top of the outdoor unit, and passes through the coil to help dislodge any loose debris.

The Auto Dust Option oP3 allows the Auto Dust Throw Mode to be called through a third-party signal at any time. When the oP3 setting is used, an LG I / O Module (sold separately) MUST be installed. When the signal is sent to the outdoor unit via a third party source (oP3), normal system operation can be interrupted, and the Auto Dust Throw function can be performed. All other settings will not interrupt the Multi V system operation.

Use on both heat pump and heat recovery systems.

Figure 21: Setting the High Efficiency Function (Auto Dust Mode).

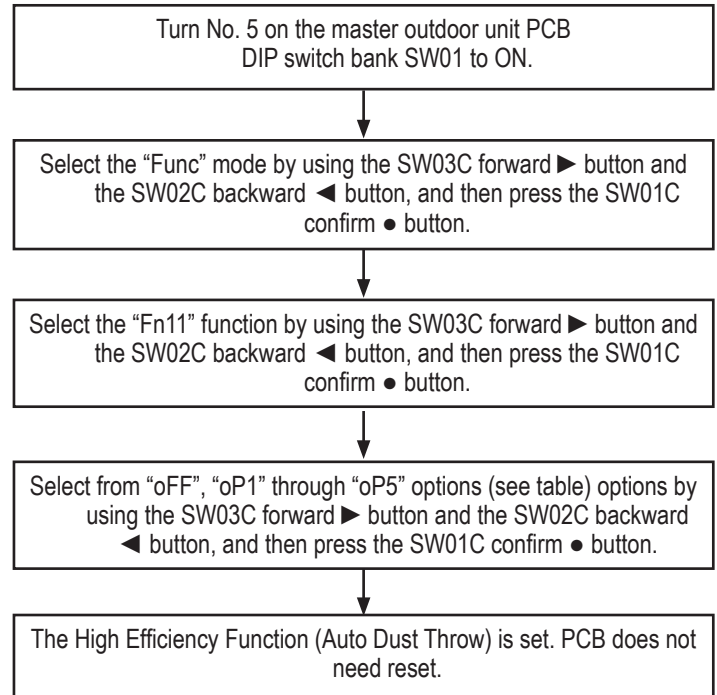

**Note:**

The Auto Dust Mode function is not a substitute for coil cleaning and does not clear the coil of all debris. A coil cleaning procedure must be included when performing regular preventative maintenance.

Table 32: Setting the High Efficiency Function (Auto Dust Mode).

Settings	Reverse Cycle Fan Runtime (Minutes)	Time Delay Between Cycles	Number of Cycles
oFF (Default)	-	-	-
oP1	5	2 Hours	No Limit
oP2	5	2 Hours	2
oP3*	3	5 Minutes Following Compressor Shutdown	1
oP4	1	-	1
oP5	1	1 Hour	2

\*op3 requires LG's I / O Module (sold separately).

## Setting Optional Modes

### Smart Load Control (SLC) Function (Fn14)

Smart Load Control Function could assist in reducing energy by lowering compressor lift during off-peak hours and shoulder seasons. The function adjusts compressor lift by reading outdoor ambient temperature, humidity (if FN16 is set to on), and current heating or cooling demand in real time (rolling twenty [20] minute log).

#### Smart Load Control Options:

- Smooth Mode (oP1): Maximize energy savings; rate of temperature change less important.
- Normal Mode (oP2): Balance the temperature change rate with the energy consumed.
- Peak Mode (oP3): Quickly cool / heat the building; energy consumption is less important.

All three (3) options only run for twenty (20) minutes of operation after a compressor start. Following the twenty (20) minute morning warm-up (or cool-down period), Smart Load Control will then use the same algorithm irrelevant of which Smart Load Control option selected. If the outdoor unit is operating in cooling, Smart Load Control adjusts the target low pressure; if the outdoor unit is operating in heating, Smart Load Control adjusts the target high pressure.

Smart Load Control can be used in almost every application except those where the outdoor unit is supporting a Dedicated Outdoor Air System (contact an LG representative for information). Smart Load Control will not have an impact on operation if the system is running in simultaneous cooling / heating (heat recovery systems only).

Use on both heat pump and heat recovery systems.

Table 33: Setting the Smart Load Control Function.

Settings	Smart Load Control Operation	Mode	Details (First Twenty [20] Minutes)
oFF (Default)	Off	Not Selected; Disabled	-
oP1	On	Smooth	Maximize Energy Savings
oP2	On	Normal	Balance the Room Temperature Rate of Change with Energy Consumed
oP3	On	Peak	Quickly Change the Temperature.

Figure 22: Setting the Smart Load Control Function.

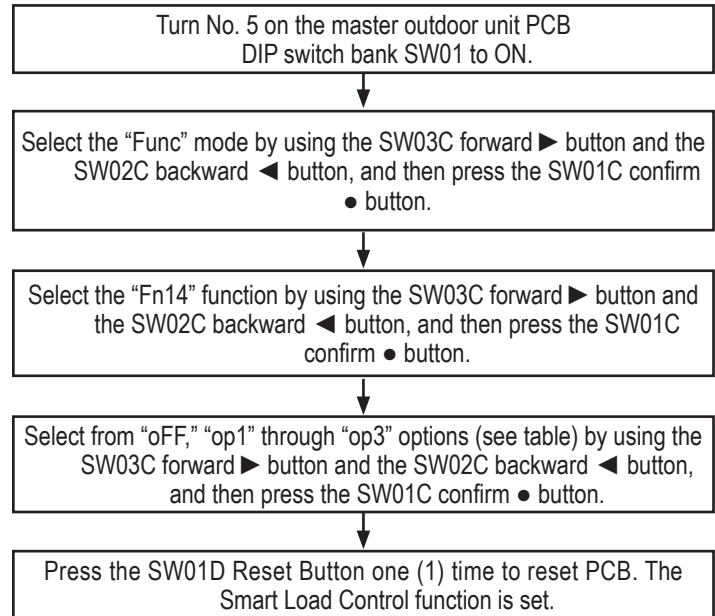

**Humidity Reference (Fn16)**

When humidity reference is selected (on), the master outdoor unit microprocessor considers the outdoor ambient humidity condition when making adjustments to the control values of the refrigeration cycle. Records humidity every minute, and uses the last twenty (20) minutes of data to calculate current humidity and dewpoint.

The Humidity Reference function is used by Smart Load Control (FN14), Comfort Cooling (ID10), and core logic Intelligent Defrost – Smart Heating algorithms to prepare the system for changes in the building load.

For use on both heat pump and heat recovery systems.

Table 34: Setting the Humidity Reference.

Settings	Function
oFF (Default)	Mode Not Set; Disabled
on	Humidity Reference On

**Note:**

- When using the Smart Load Control in cooling mode, the Humidity Reference function could assist in improving energy savings because the evaporation temperature decreases.
- If high humidity conditions exist when the system is operating in heating mode, defrost mode will be delayed because target high / low pressure will be changed (Intelligent Defrost - Smart Heating).
- If Comfort Cooling is selected for one (1) or more indoor units, then the superheat reset will be delayed or will not reset at all under humid outdoor conditions.

**Power Consumption Display (Fn21)**

The function tells the outdoor unit (master outdoor unit if a multi-frame system) that power consumption must be monitored. The function also communicates to the outdoor unit if it will be responsible for reporting the data to the central control device(s), or if an (optional) LG Power Distribution Integrator (PDI) will be responsible for reporting.

When the optional PDI is installed, the PDI will monitor outdoor unit power consumption. PDI allocates outdoor unit power consumed to indoor units based on the volume of refrigerant flow through each indoor unit during the billing period.

Power consumption data can then be viewed using an LG ACP or AC Smart central controller, LG MultiSite Communications Manager, and LG zone controllers. For installations where a third-party BMS system is present, consumption data is also made available for through LG’s BACnet Gateway.

For use on both heat pump and heat recovery systems.

Table 35: Setting the Power Consumption Function.

Settings	Power Monitoring
oFF (Default)	No Power Monitoring
Pd10	Outdoor Unit Assigned Reporting Duty
Pd11	PDI Installed and Assigned Reporting Duty

Figure 23: Setting the Humidity Reference Function.

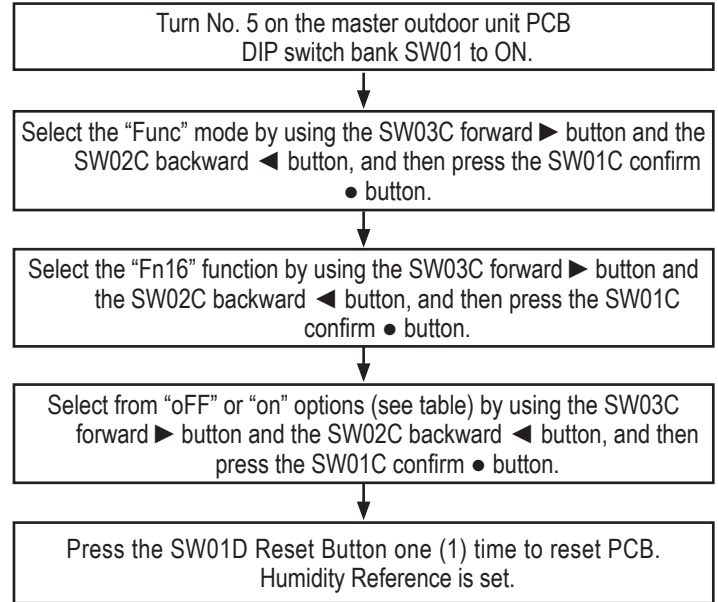
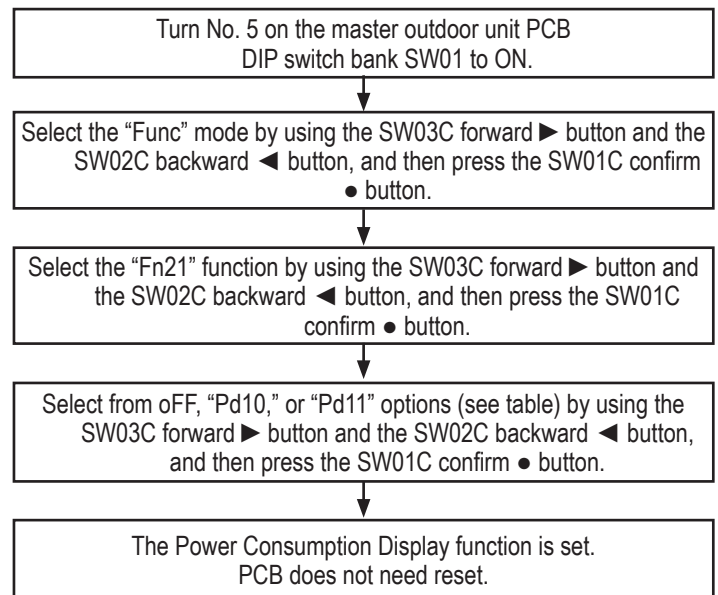

Figure 24: Setting the Power Consumption Display Function.



## Setting Optional Modes

### Overall Defrost Operating in Low Temperatures (Heating) (Fn22)

The Overall Defrost Operating in Low Temperatures function overrides LG's Intelligent Defrost algorithm, and first defrosts the lower half of the coil, and then defrosts the full coil. On multi-frame systems, all frames are in defrost simultaneously. Defrost operation occurs every three (3) hours, irrespective of need, whenever the outdoor air temperature is  $\leq 14^{\circ}\text{F}$ .

Used in locations where heavy snow fall is prevalent, or when a small amount of ice build-up on the outdoor unit coil has a noticeable impact on building comfort.

Overall Defrost Operating in Low Temperatures can also be used with Fn4 - Overall Defrost, Fn6 - Snow Removal Assist / Rapid Defrost, and SE6 - Forced Defrost.

For use on both heat pump and heat recovery systems.

Table 36: Setting the Overall Defrost Operating in Low Temperatures (Heating).

Settings	Overall Defrost Operating in Low Temperatures Enabled
oFF (Default)	No
on	Yes

### Drain Pan Heater (Optional) Function (Fn23)

Informs the master outdoor unit microprocessor that an optional field-installed drain pan heater (sold separately) is installed. The optional drain pan heater maintains the bottom of the outdoor unit  $>32^{\circ}\text{F}$  to keep condensate from freezing.

Selecting to engage this option must only be done if a properly sized pan heater is in place to keep the bottom surface of the outdoor unit  $>32^{\circ}\text{F}$ . The microprocessor will power outdoor unit PCB terminal CN25 when at least one (1) compressor in the frame is operating, the outdoor air temperature is  $<39^{\circ}\text{F}$ , and either the following conditions occur:

1. Outdoor unit is operating in heating.
2. Outdoor unit is in defrost.

The controller will shut off the drain pan heating operation when the outdoor air temperature rises  $>39^{\circ}\text{F}$ , or when all compressors stop operating.

For use on both heat pump and heat recovery systems.

#### Note:

On multi-frame systems, it is possible for one (1) or more frame(s) to be operating in heating, and have another frame operating in cooling. Setting value must be set on a per frame basis on multi-frame systems.

Figure 25: Setting the Low Temperatures Defrost Function (Heating).

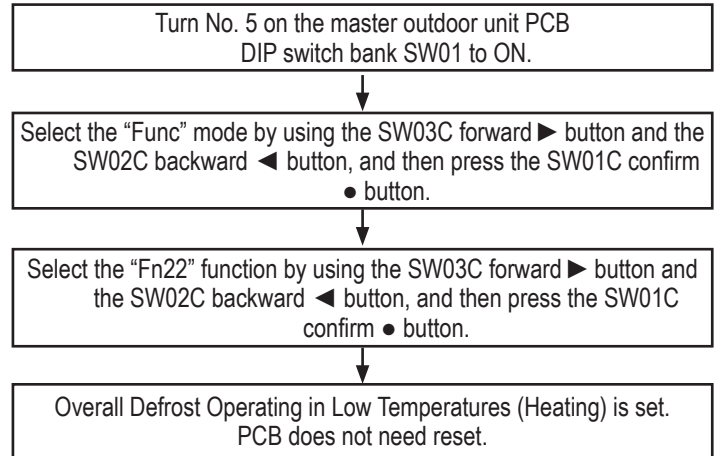

Figure 26: Setting the Drain Pan Heater Function.

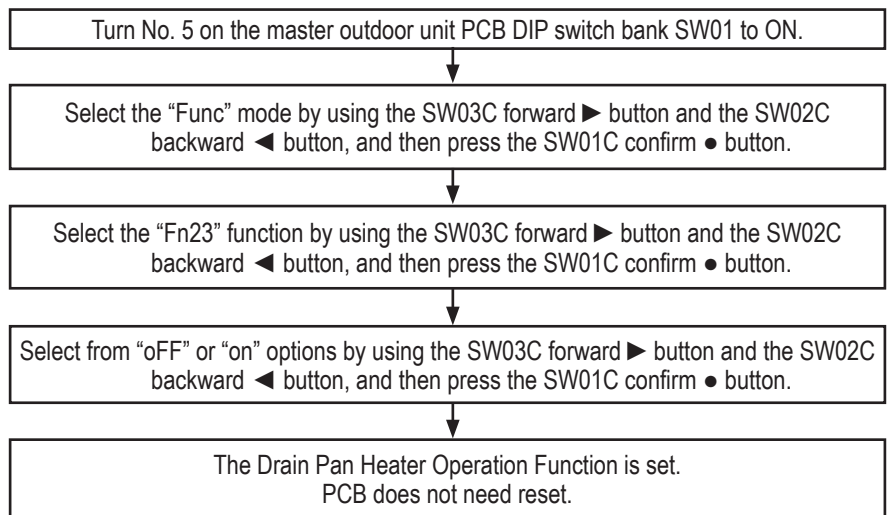

Table 37: Setting the Drain Pan Heater Function.

Settings	Drain Pan Heater Kit Installed
oFF (Default)	No
on	Yes

**Comfort Cooling (Id10)**

When comfort cooling is on, the indoor unit cooling coil target superheat value is increased in steps as the space temperature approaches the setpoint temperature (rate of outdoor temperature change and humidity influence the superheat adjustment). This results in warmer chilled air coming from the indoor unit. The function extends cooling operation run time. Comfort Cooling must be set on an indoor unit to indoor unit basis unless the apply to all option is selected.

For use on both heat pump and heat recovery systems.

Table 38: Setting Comfort Cooling Operation.

Settings	Function
00	OFF, Default;  Do Not Use Comfort Cooling on the Selected Indoor Unit.
01	4°C (7.2°F)
02	2°C (3.6°F)
03	1°C (1.8°F)

Figure 27: Setting the Comfort Cooling Operation Mode.

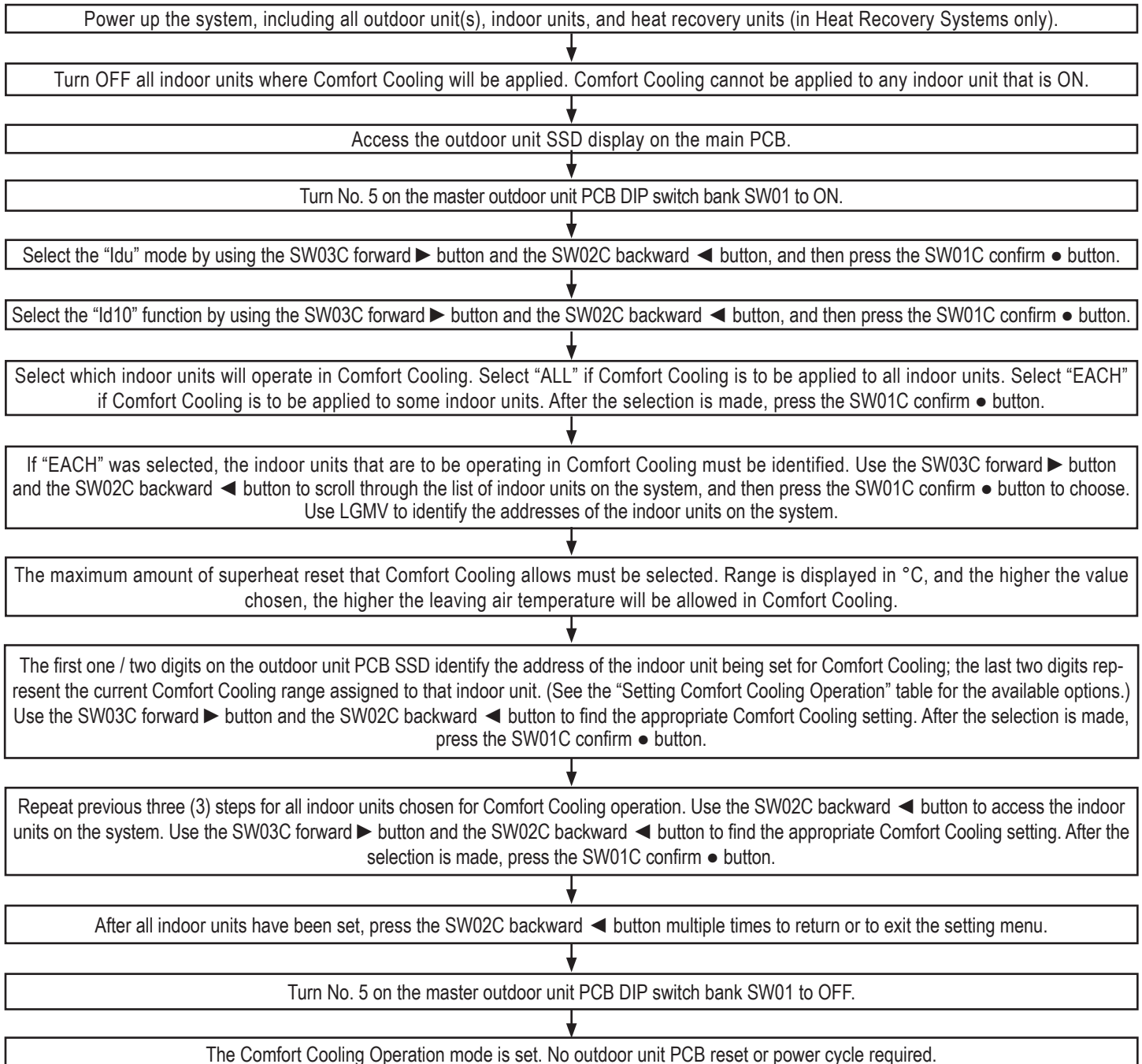

## Setting Optional Modes

### Pump Down (SE1, Pd)

Pump Down function gathers the refrigerant in the system, and sends it to the outdoor unit. Use Pump Down function when there is a refrigerant leak, or if an indoor unit needs to be replaced. The maximum refrigerant for outdoor units is size dependent and varies between 14.3 and 37.5 lbs per frame. If the system charge is greater than the volume that can be stored, a supplemental vacuum pump and third-party storage containers will be required. Set Pump Down mode on the master outdoor unit, but all outdoor units will function while the system is in Pump Down. For use on both heat pump and heat recovery systems.

Table 39: Setting the Pump Down Function.

Settings	Function
oFF (Default)	Pump Down is not enabled.
Pd (on)	Pump Down is enabled. Display Will Show Low Pressure.

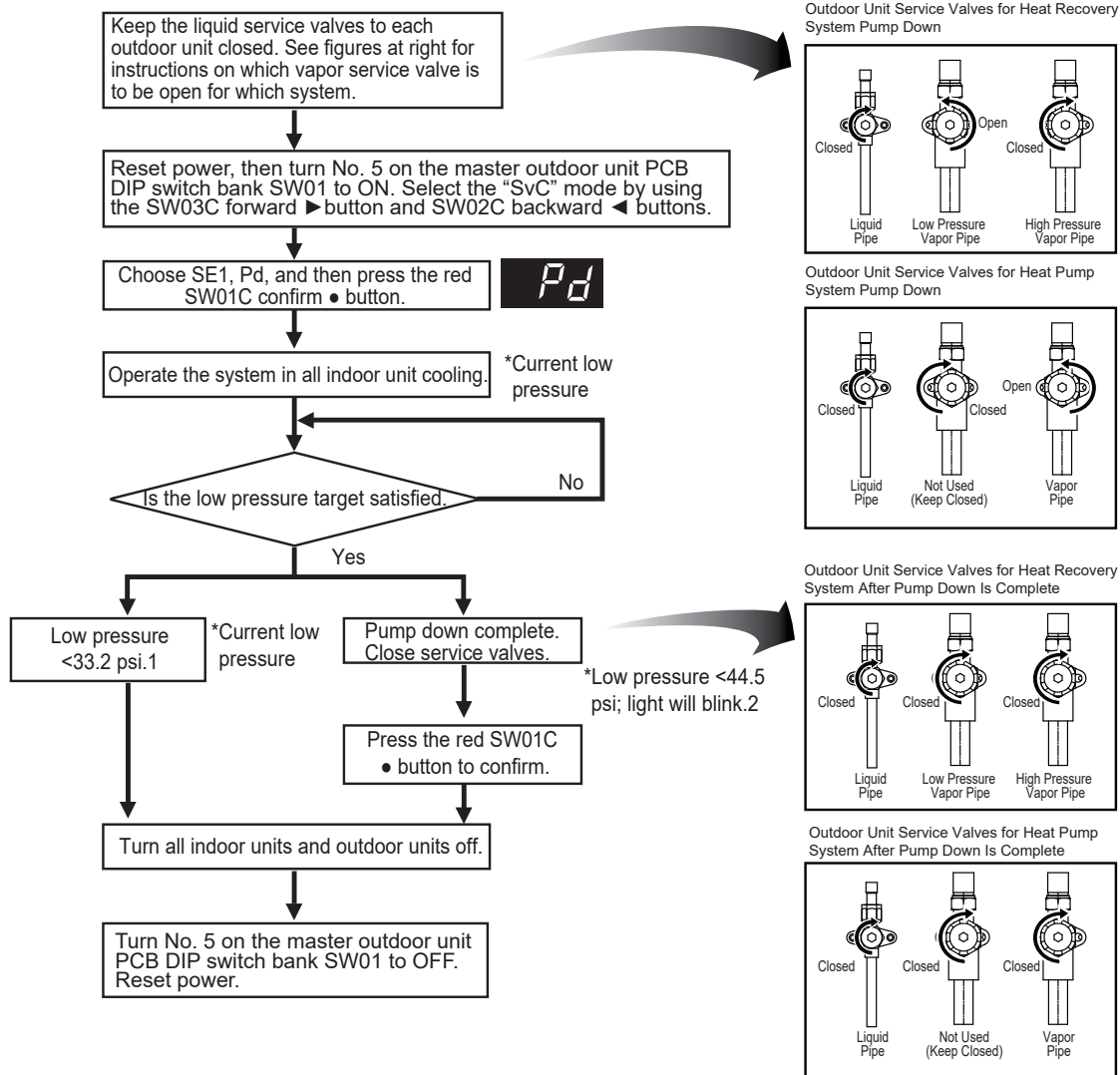

### Note:

- If low pressure falls below 33.2 psi, the system will automatically turn off. Immediately close the vapor service valves. (See figures above.)
- If low pressure falls below 44.5 psi (light will blink), immediately close the vapor service valves of all outdoor units.

### Note:

- Use the Pump Down function while ambient conditions are within the manufacturer's operating temperature ranges: Indoor Units = 68-89.6°F; Outdoor Units = 41-104°F.
- Do not run the indoor units in thermo off mode during Pump Down.
- Maximum operation time of Pump Down is thirty (30) minutes (in case low pressure does not satisfy target levels immediately).

**Pump Out (SE2, Po)**

The Pump Out function pushes refrigerant from a malfunctioning outdoor unit to other outdoor units, indoor units, and the building piping system. Use this function if an outdoor unit compressor fails, if a part is defective and needs to be replaced, or if there is a leak. In systems with short piping systems, the refrigerant amount that can be pumped from the outdoor unit will be limited, and additional refrigerant storage containers will need to be used. Set Pump Out mode on the master outdoor unit, but all outdoor units will function while the system is in Pump Out. For use on both heat pump and heat recovery systems.

Table 40: Setting the Pump Out Function.

Settings	Function
oFF (Default)	Pump Out is not enabled.
Po (on)	Pump Out is enabled. Display Will Show Low Pressure.

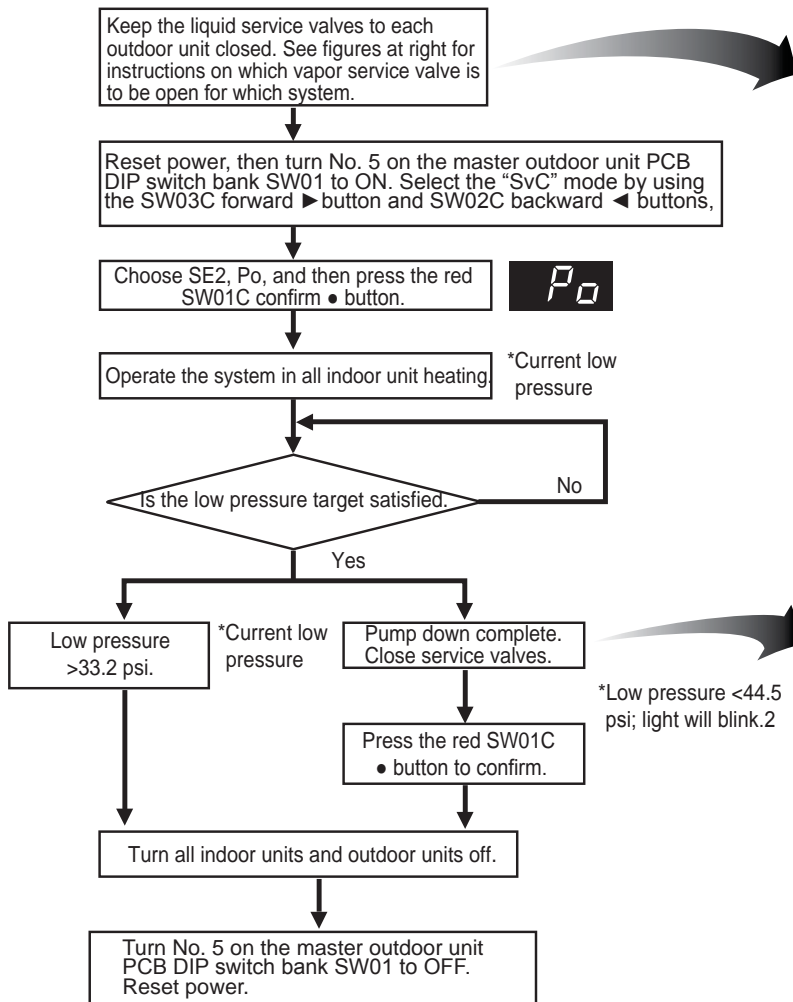

Outdoor Unit Service Valves for Heat Recovery System Pump Out

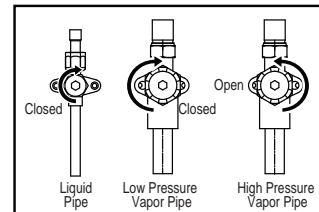

Outdoor Unit Service Valves for Heat Pump System Pump Out

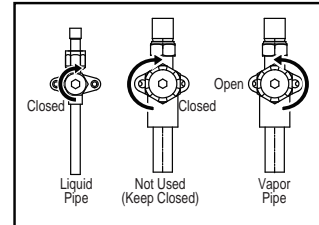

Outdoor Unit Service Valves for Heat Recovery System After Pump Out Is Complete

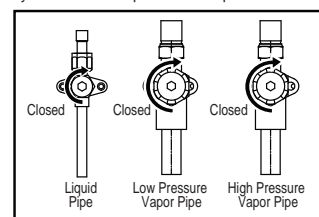

Outdoor Unit Service Valves for Heat Pump System After Pump Out Is Complete

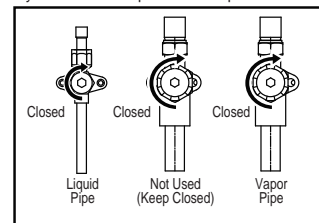

Outdoor Unit Functions

**Note:**

1. If low pressure falls below 33.2 psi, the system will automatically turn off. Immediately close the vapor service valve of all outdoor units (Heat Pump systems only). (See figures above.)
2. If low pressure falls below 44.5 psi (light will blink), immediately close the vapor service valves of all outdoor units.

**Note:**

- Use the Pump Out function while ambient conditions are within the manufacturer's operating temperature ranges: Indoor Units = 50-89.6°F; Outdoor Units = 41-104°F.
- Do not run the indoor units in thermo off mode during Pump Out (in case low pressure does not satisfy levels).
- Maximum operation time of Pump Out takes two (2) to five (5) minutes after the compressor starts.

## Setting Optional Modes

### Pump Out for Heat Recovery Systems

Example of Pump Out Function When Slave2 Outdoor Unit Experiences Inverter Compressor Failure.

● Closed ○ Open

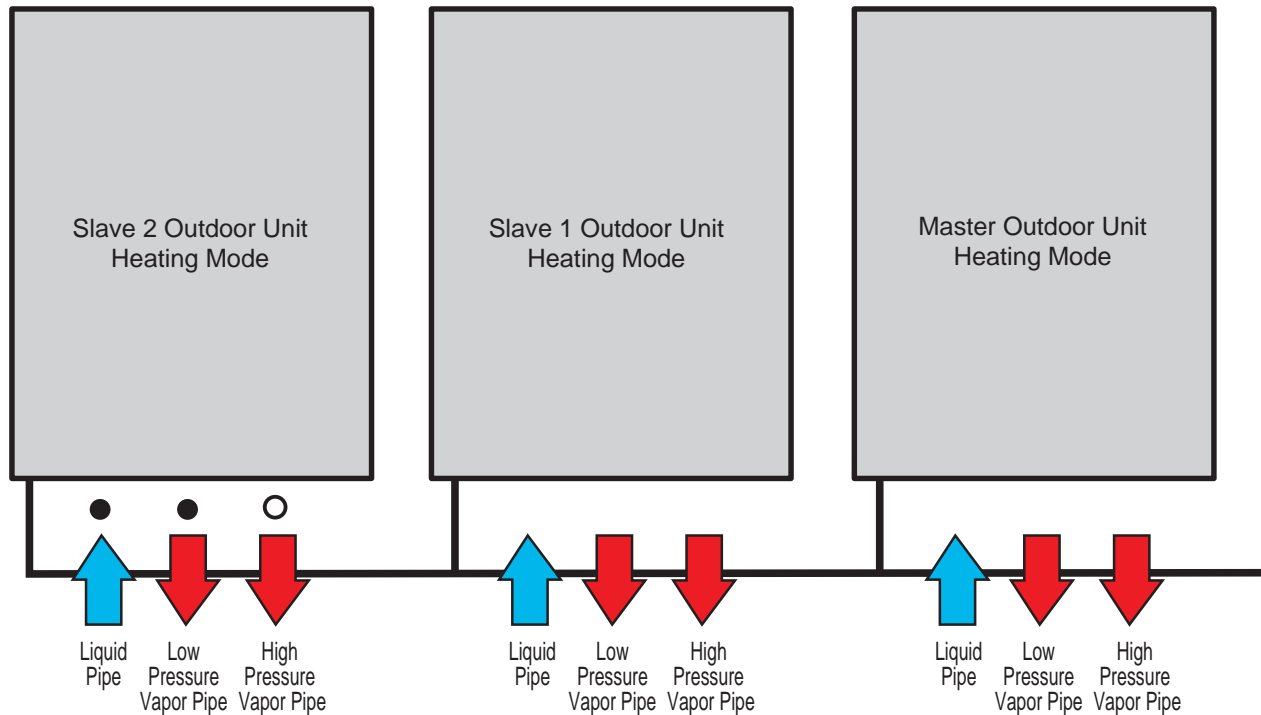

1. Verify the liquid pipe and low pressure vapor pipe of the outdoor unit are closed for Pump Out operation. Open the high pressure vapor pipe service valve.
2. Operate Pump Out function.
3. Close high pressure vapor pipe of unit after Pump Out is complete.
4. Replace inverter compressor, eliminate remaining refrigerant of the corresponding outdoor unit, and perform Vacuum procedure using Vacuum Mode.
5. Add refrigerant using the Refrigerant Auto Charge Function.

Figure 28: Close Up of Heat Recovery Service Ports and Refrigerant Charge Valve.

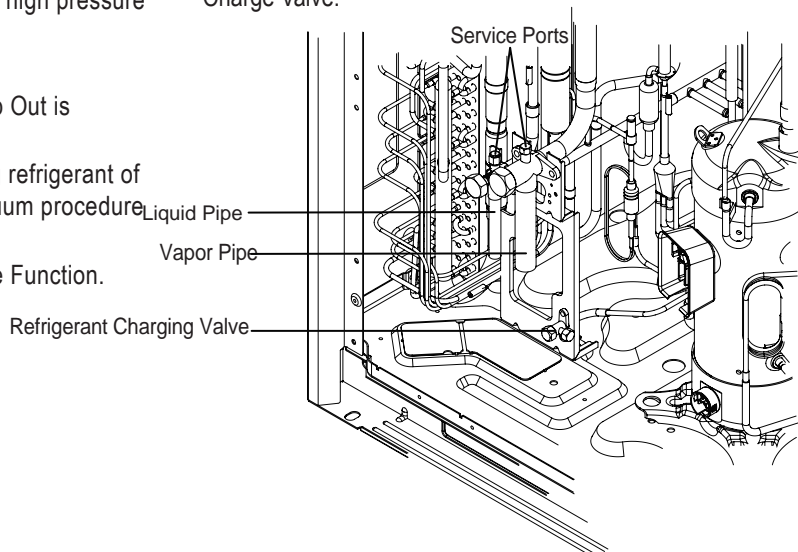

**Pump Out for Heat Pump Systems**

Example of Pump Out Function When Slave2 Outdoor Unit Experiences Inverter Compressor Failure.

● Closed ○ Open

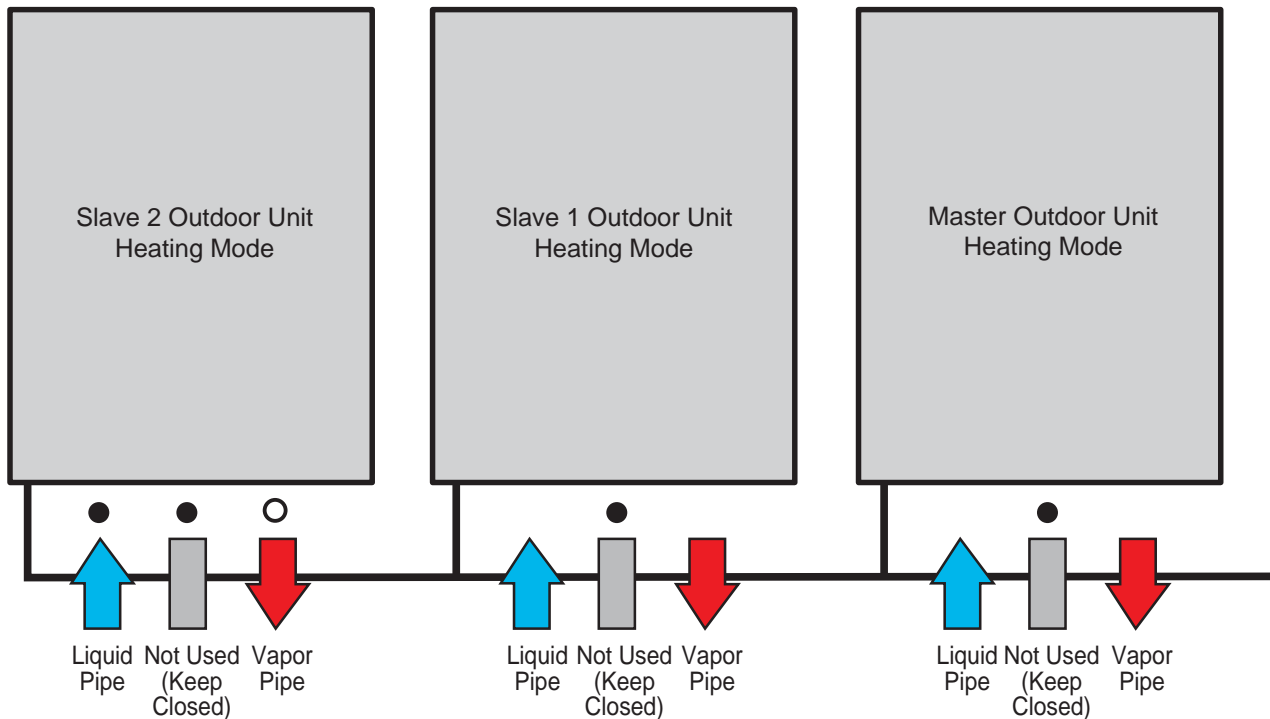

Outdoor Unit Functions

1. Verify the liquid pipe of the outdoor unit is closed for Pump Out operation. Open the vapor pipe service valve.
2. Operate Pump Out function.
3. Close the vapor pipe service valve of unit after Pump Out is complete.
4. Replace inverter compressor, eliminate remaining refrigerant of the corresponding outdoor unit, and perform Vacuum procedure using Vacuum Mode.
5. Add refrigerant using the Refrigerant Auto Charge Function.

Figure 29: Close Up of Heat Pump Service Ports and Refrigerant Charge Valve.

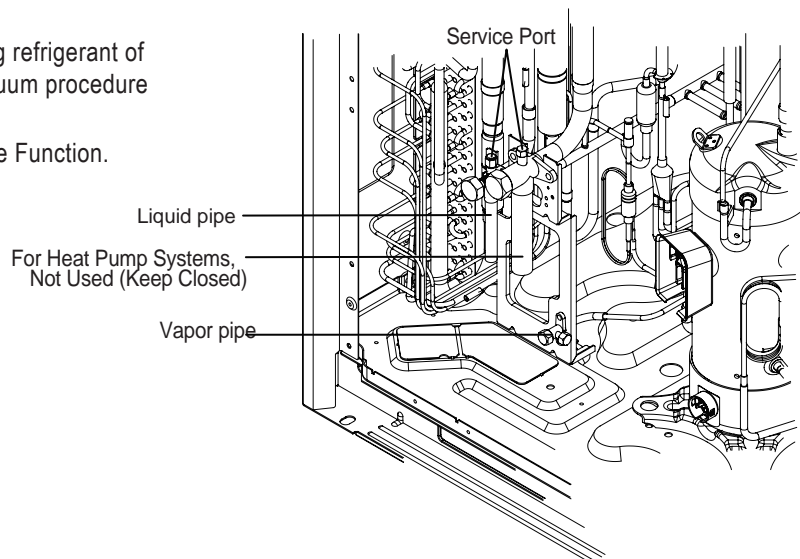

## Setting Optional Modes

### Vacuum Mode (SE3, vAcc)

The vacuum mode can be used as an option for creating vacuum in the system when the outdoor unit is first installed, if power is available, and if the system has already been auto addressed. Vacuum mode enables the system to fully open all valves, and can help speed up the evacuation process.

Vacuum mode can also be used when compressor and / or outdoor unit parts are replaced, or when an indoor unit is added or replaced.

1. Turn No. 5 on the master outdoor unit PCB DIP Switch SW01 to ON.
2. Select the "SvC" mode By using the ► and ◀ buttons, then push the ● button.
3. Select the "SE3" function By using the ► and ◀ Buttons, then push the ● button.
4. Press the SW01D Reset Button one (1) time to reset PCB, and start the vacuum mode "vACC". In vacuum mode, the outdoor unit valve is open, the outdoor unit EEV is open, and the indoor unit(s) EEV(s) is/are open. The heat recovery unit(s) valve(s) and EEVs are open (if system includes heat recovery units).
5. To cancel the vacuum mode, turn No. 5 on the master outdoor unit PCB DIP Switch SW01 to OFF, and push the SW01D reset button on the outdoor unit PCB. On a multi-frame system, push the SW01D reset button on ALL outdoor units.

Figure 30: Vacuum Mode Setting Locations.

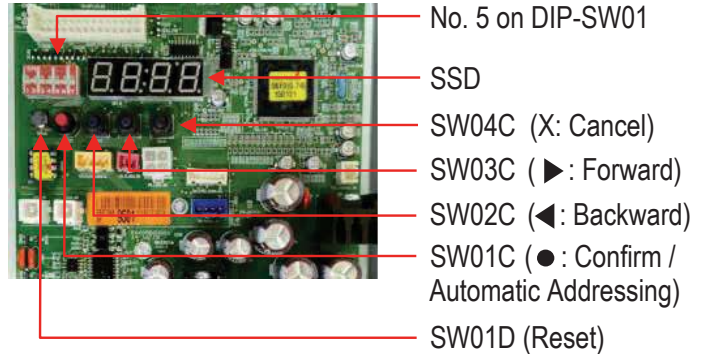

No. 5 on DIP-SW01

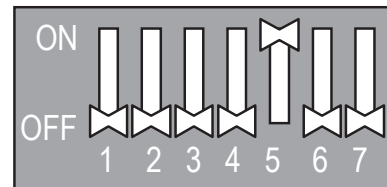

#### Setting Vacuum Mode

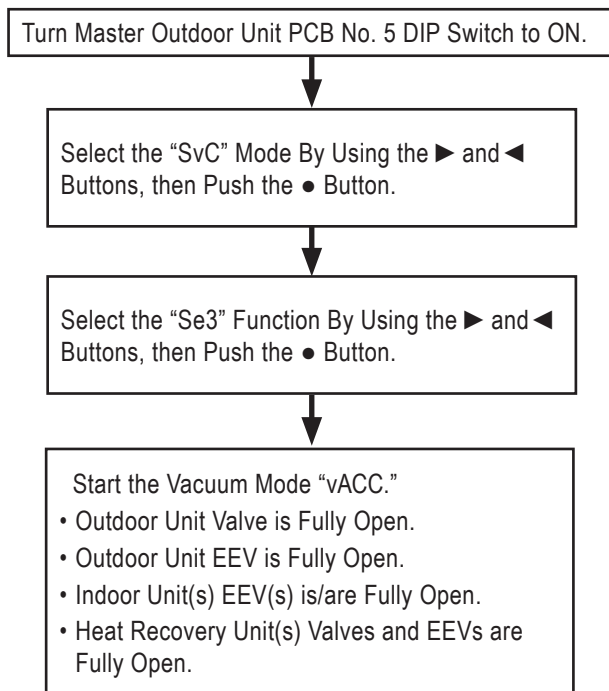

#### Canceling Vacuum Mode

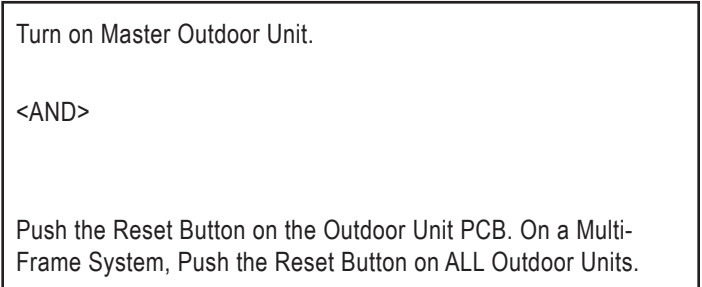

#### Note:

- Outdoor unit operation stops during Vacuum Mode, so the compressor cannot operate.
- Limit vacuum mode to less than 48 hours of continuous operation. If vacuum mode is not stopped, the system will continue to operate with all EEVs and valves open on the non-vacuum mode terminated slave outdoor units. The refrigerant will flood back to the compressors on those non-vacuum mode terminated slave outdoor units, which will result in poor operation, equipment malfunction and / or compressor damage.

### Manual Back Up for Inverter Compressor (SE4)

The Manual Back Up function allows the system to operate if an inverter compressor fails (defective compressor operation is halted), manually backing up the compressor until it is serviced to an operating condition or replaced. It informs the outdoor unit microprocessor that one compressor is not available for operation. It does not isolate the refrigerant flow between the compressor and the piping system.

Error can be displayed every six (6) hours.

For use on both heat pump and heat recovery systems.

**Note:**

The Manual Back Up for Inverter Compressor function requires the LG trained service provider to set the microprocessor on the specific outdoor unit with the malfunctioning compressor.

Table 41: Setting Manual Back Up Function.

Settings	Function
oFF (Default)	Manual Back Up is Disabled. All Compressors are Operating Normally.
inv1	Compressor Number 1 Malfunctioning; Manual Back Up is Enabled.
inv2	Compressor Number 2 Malfunctioning; Manual Back Up is Enabled.
Unit Backup	Unit Backup is Enabled.

**Note:**

- The Manual Back Up for Inverter Compressor function is for temporary use only. Leaving a damaged compressor in an outdoor unit for an extended period will lead to multiple compressor failures in the system.
- ⚠ Do not forget to turn this function OFF after the compressor is replaced.

### Forced Oil Return (SE5, 01)

The Forced Oil Return function overrides LG’s Smart Oil Management algorithm, replacing it with a timed oil return that initiates every fifteen minutes when the sensor indicates the oil level is low. Use the function in applications where oil return has been problematic, a compressor failed due to low oil and the cause is unknown.

For use on both heat pump and heat recovery systems.

Table 42: Setting Forced Oil Return Function.

Settings	Function
oFF (Default)	Forced Oil Return is Disabled.
01	Forced Oil Return is Enabled. Oil Return Occurs Every Fifteen (15) Minutes When Low.

Figure 31: Setting the Manual Back Up for Inverter Compressor Function.

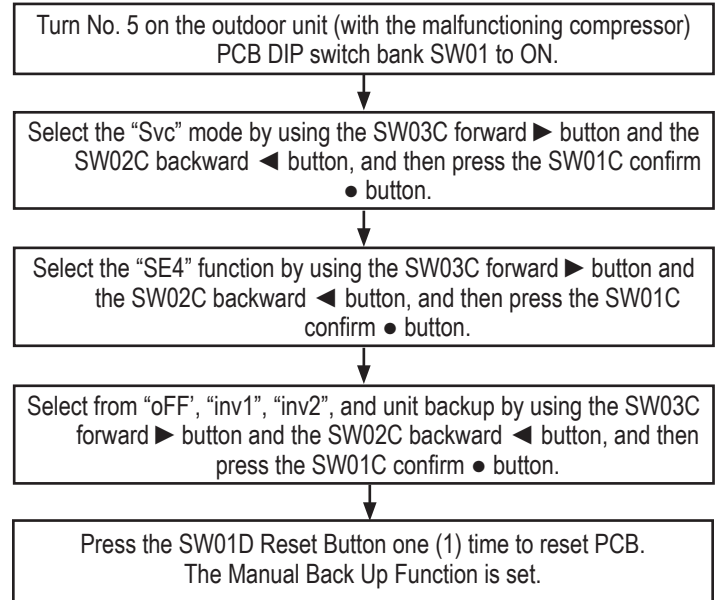
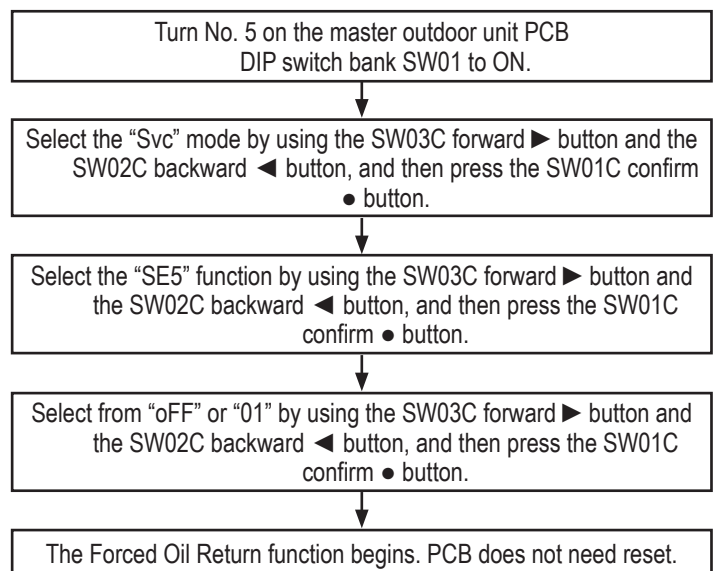

Figure 32: Setting the Forced Oil Return Function.



## Setting Optional Modes

### Forced Defrost (SE6, dEF)

The Forced Defrost function overrides LG's Intelligent Defrost algorithm when the outside ambient air temperature is <14°F, occurring every three (3) hours irrelevant of need. Use the function when defrost at low ambient temperatures does not completely clear the coil, and the frost that remains impacts comfort levels. It can also be used on installations where the outdoor unit heating capacity needs to be optimized at all times during low ambient operation to maintain comfort.

On single outdoor unit systems, Forced Defrost will defrost the lower half of the coil for four (4) minutes, followed by a twenty (20) minute full coil defrost (total defrost cycle time is twenty-four [24] minutes). On multi-frame systems, the entire coil on each frame will defrost concurrently (total system defrost cycle time is twenty [20] minutes).

For use on both heat pump and heat recovery systems.

Forced Defrost can also be used with Fn4 - Overall Defrost, Fn6 - Snow Removal Assist / Rapid Defrost (oP2 or oP3), and Fn22 - Overall Defrost Operating in Low Temperatures. Combining all of these functions will result in the most aggressive defrost capability.

Table 43: Setting Forced Defrost Function.

Settings	Function
oFF (Default)	Forced Defrost is Disabled.
dEF	Forced Defrost is Enabled. Oil Return Occurs Every Three (3) Hours Irrelevant of Need.

Figure 33: Setting the Forced Defrost Function.

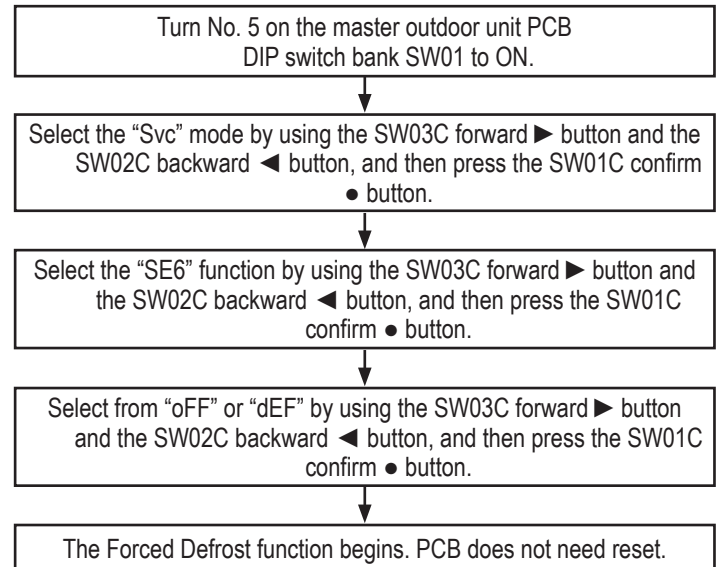

**Cycle Data View (SE8)**

Cycle Data View displays the cycle data of the operating outdoor unit. Cycle Data View can display 26 different cycle datapoints on the SSD.

For use on both heat pump and heat recovery systems.

Figure 34: Setting the Cycle Data View Function.

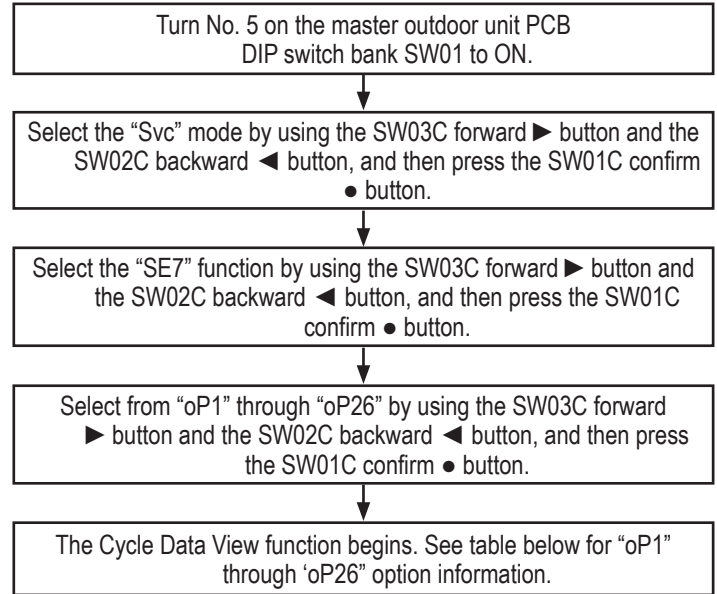

Table 44: Cycle Data View Datapoint Options.

Option	Description	Display	Example	seg_1	seg_2	seg_3	seg_4
op1	Current High Pressure	P1	4,320.9 kPA (626.7 psi)	4	3	2	1
op2	Current Low Pressure	P2	1,234.2 kPA (179 psi)	1	2	3	4
op3	Inv 1 Pulse	h1	120 Hz		1	2	0
op4	Inv 2 Pulse	h2	30			3	0
op5	Fan RPMs	h3	110		1	1	0
op6	Degree of Subcooling	T1	5.3°C (41.5°F)			5	3
op7	Degree of Superheating	T2	-4.5°C (23.9°F)		-	4	5
op8	Outdoor Unit Temperature	T3	10°C (50°F)		1	0	0
op9	Suction Temperature	T4	43.4°C (110.1°F)		4	3	4
op10	Compressor 1 Discharge Temperature	T5	150°C (302°F)		1	5	0
op11	Compressor 2 Discharge Temperature	T6	124°C (255.2°F)		1	2	4
op12	Liquid Pipe Temperature	T7	10°C (50°F)		1	0	0
op13	Sc_in	T8	10°C (50°F)		1	0	0
op14	Sc_out	T9	10°C (50°F)		1	0	0
op15	Hex_total	T10	10°C (50°F)		1	0	0
op16	Hex_hi	T11	10°C (50°F)		1	0	0
op17	Hex_low	T12	10°C (50°F)		1	0	0
op18	Inlet Pipe Temperature of Indoor Unit	T13	-10°C (14°F)	-	1	0	0
op19	Main 1 EEV	PLS1	1,940	1	9	4	0
op20	Main 2 EEV	PLS2	32			3	2
op21	SC EEV	PLS3	16			1	6
op22	Oil EEV	PLS4	50			5	0
op23	vi eev 1	PLS5	1,350	1	3	5	0
op24	vi eev 2	PLS6	8				8
op25	Operation Capacity of Indoor Units	IDU1	24,000			2	4
op26	Total Number of Indoor Units	IDU2	10			1	0

## Setting Optional Modes

### Refrigerant Sound Reduction Mode (SE9)

This function reduces refrigerant flow sound in the liquid piping caused by mixed-state refrigerant by adjusting air flow across the outdoor unit coil. It reduces the refrigerant flow sound at all indoor units when system is operating in heating or cooling. The function will impact all indoor units; selective indoor unit application is not possible.

In cooling, when the compressor speed remains constant, reducing the airflow over the outdoor unit coil raises head pressure and sub-cooling. Increased sub-cooling reduces the possibility that gas bubbles will form in the liquid line before reaching the indoor unit EEVs.

In heating, when the compressor speed remains constant, the temperature of the superheated gas leaving the compressor and entering the indoor coil is reduced. This results in slightly less heating performance, but sub-cooling rises in the liquid leaving the indoor (condenser) coil. More sub-cooling keeps gas bubbles from forming before the liquid passes through the condenser coil EEV valve.

Can be used with Fn14 - Smart Load Control and Id10 - Comfort Cooling without severely impacting the energy saved or reducing comfort levels

For use on both heat pump and heat recovery systems.

#### Note:

- Because of the restricted refrigerant flow, it will take longer to preheat the coil on startup.
- An incorrect charge can result in refrigerant flow related sound. Verify the system's refrigerant charge is correct before using this function.

Table 45: Setting the Refrigerant Sound Reduction Function.

Settings	Adjustment	Description
oFF (Default)	Normal RPM	No Adjustment
oP1	Normal - 200	Outdoor Unit Fan Speed Reduced by 200 RPM
oP2	Normal - 100	Outdoor Unit Fan Speed Reduced by 100 RPM

Figure 35: Setting the Refrigerant Sound Reduction Function.

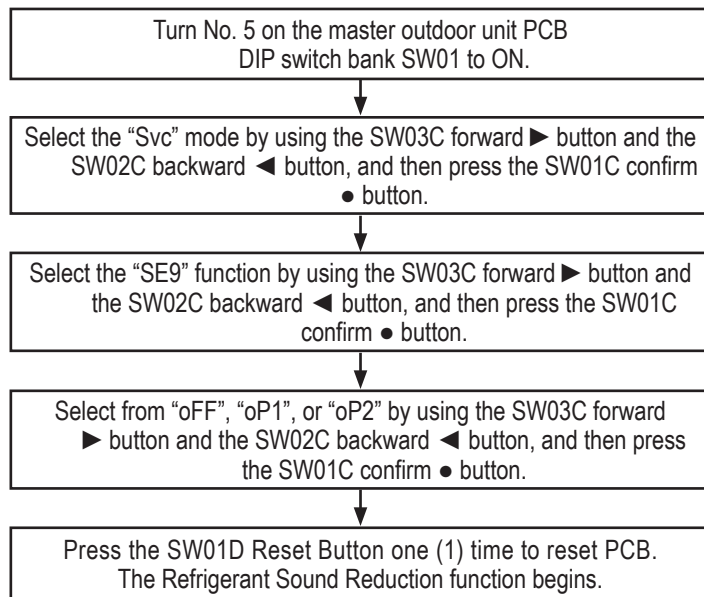

**Fan Low Sound in Heating (SE11)**

The Fan Low Sound in Heating mode reduces outdoor unit fan speed when the system is in heating and the system has a light load. Use when the outdoor units are installed in sound-sensitive area.

The mode operates only when:

- Outdoor unit coil temperature is >38°F.
- Air temperature is <41°F.
- Heating load is <30% of total indoor unit capacity.
- Refrigerant heating effect is reduced, however, is not needed.
- Refrigerant flow sound (if any is present) is reduced through actively heating indoor units.

For use on both heat pump and heat recovery systems.

Table 47: Setting the Fan Low Sound in Heating Function.

Settings	Function
oFF (Default)	Fan Low Sound in Heating is Not Enabled.
on	Fan Low Sound in Heating is Enabled.

**Number of Partial Defrosts (SE12)**

Sets the number of split-coil (or split-frame on multi-frame systems) defrost cycles occurring between the full-frame defrost cycles. Use the function in areas where the winter temperatures are mild (above freezing), only light frost or ice occurs, or if the building has significant air leaks and the system might need to operate in heating as much as possible.

- Selections range from one (1) to eleven (11)
- In areas where winter weather is milder, select a higher value.

SE12 function settings are ignored if Fn4 - (Overall) Defrost and / or Fn22 - Overall Defrost Operating in Low Temperatures is / are selected.

For use on both heat pump and heat recovery systems.

Table 46: Setting the Number of Partial Defrosts Function.

Settings	Partial Defrosts Cycles
oFF (Default)	Function not set; 2 is factory set
oP1	1
oP2	2
oP3	3
oP4	4
oP5	5
oP6	6
oP7	7
oP8	8
oP9	9
oP10	10
oP11	11

Figure 37: Setting the Fan Low Sound in Heating Function.

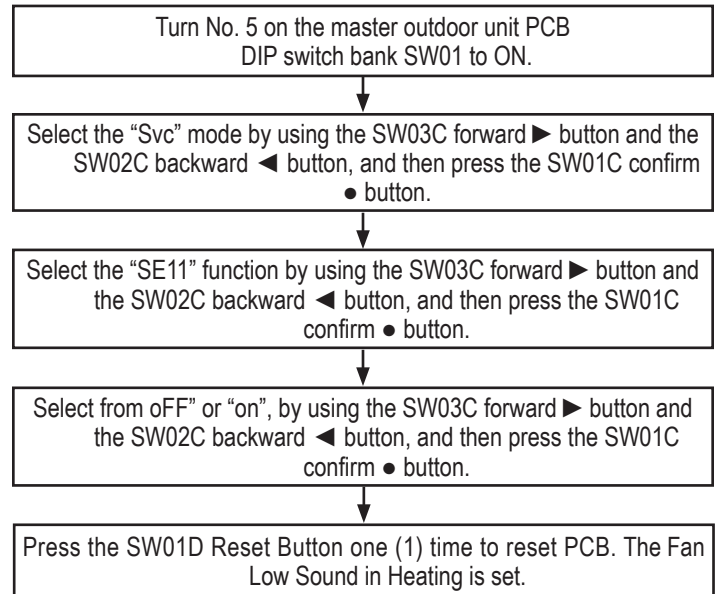
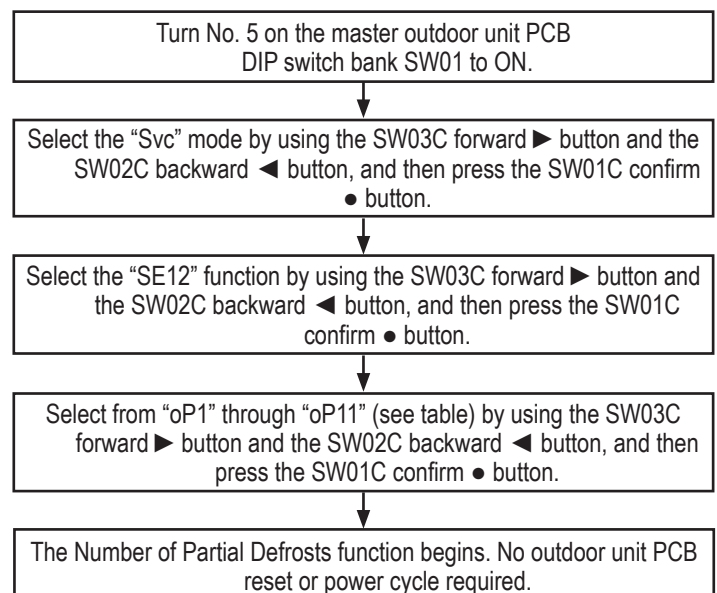

Figure 36: Setting the Number of Partial Defrosts Function.



## Setting Optional Modes

### Level Change of Error Code CH200 (SE14)

Error code CH200 is an “Auto pipe search failure - Failure to find an indoor unit,” and displays on all zone controllers, central controllers, and BACnet and LonWorks gateways. After auto operation, Error Code CH200 will display if the number of the indoor units detected is different from the number of communicating indoor units. The response to Error Code CH200 is usually a Level 1 type, which will shut down the outdoor unit(s). The Level Change of Error Code CH200 function will change the Level 1 response to a Level 3, which allows the system to operate instead of automatically shutting down. The system shuts down with an Error Code CH200 if there is one (1) or more indoor unit(s) that have no power and the possibility exists that an electronic expansion valve is open, or if liquid could return to the compressor. Apply this function only after confirming that all indoor units without power (or indoor units that cannot establish communication with the outdoor unit) have expansion valves in the closed position.

Use in applications where the LG-trained service technician wants to restart a system for diagnostic purposes, or to operate the system for an extended period with no power to one (1) or more indoor units. The system can operate safely without damage to the compressor if:

- The indoor unit(s) currently without power / communication was (were) turned off using the on / off button;
  - The last operating mode for the indoor unit(s) currently without power / communication was (were) Fan Only (thermal off);
  - The LG-trained service technician confirmed the expansion valve for the indoor unit(s) currently without power / communication was (were) closed using LGMV;
  - The space temperature was well above / below the setpoint, and the indoor unit(s) currently without power / communication was (were) not calling for heating or cooling (thermal off condition was confirmed);
- or;
- Isolation valves on both the liquid and vapor piping are closed.

The error code cannot be removed until the malfunction is fixed, a successful auto pipe search function is complete, and the outdoor unit PCB is reset using the SW01D Reset Button.

For use on heat recovery systems only.

Table 48: Setting the Level Change of Error Code CH200 Function.

Settings	Function
oFF (Default)	Level Change of Error Code CH200 is Not Enabled. Level 1 / Outdoor Unit Shutdown and Manual Restart Required.
on	Level Change of Error Code CH200 is Enabled. Level 3 / Outdoor Unit Continues Operation and CH200 Error Code is Displayed

#### Note:

When this function is enabled (Level 3), the LG-trained service technician must not leave the system unmonitored without re-establishing power and communication to all indoor units, or locking out all indoor units that are not properly communicating with the outdoor unit. Leaving the outdoor unit operating with CH200 unresolved creates a potential for compressor slugging (and eventual damage) if the error code was due to indoor unit power loss.

#### Note:

During initial system commissioning (or re-commissioning) Error No. CH200: Pipe Detection Error – failure to find indoor unit”, by default, calls for an immediate shutdown without first performing any auto restart attempts. For more information on CH200, see the Troubleshooting section.

Figure 38: Setting the Level Change of Error Code CH200 Function.

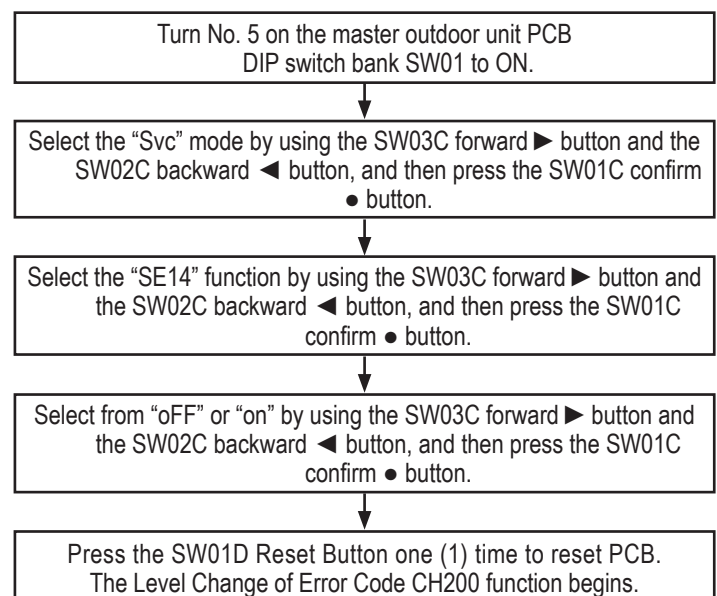

**Auto Back Up for Inverter Compressor**

The Auto Back Up function allows the system to operate if an inverter compressor fails, automatically backing up the compressor (defective compressor operation is halted). No need to set a code for this feature—this function operates automatically using system logic. Errors can be displayed every six (6) hours.

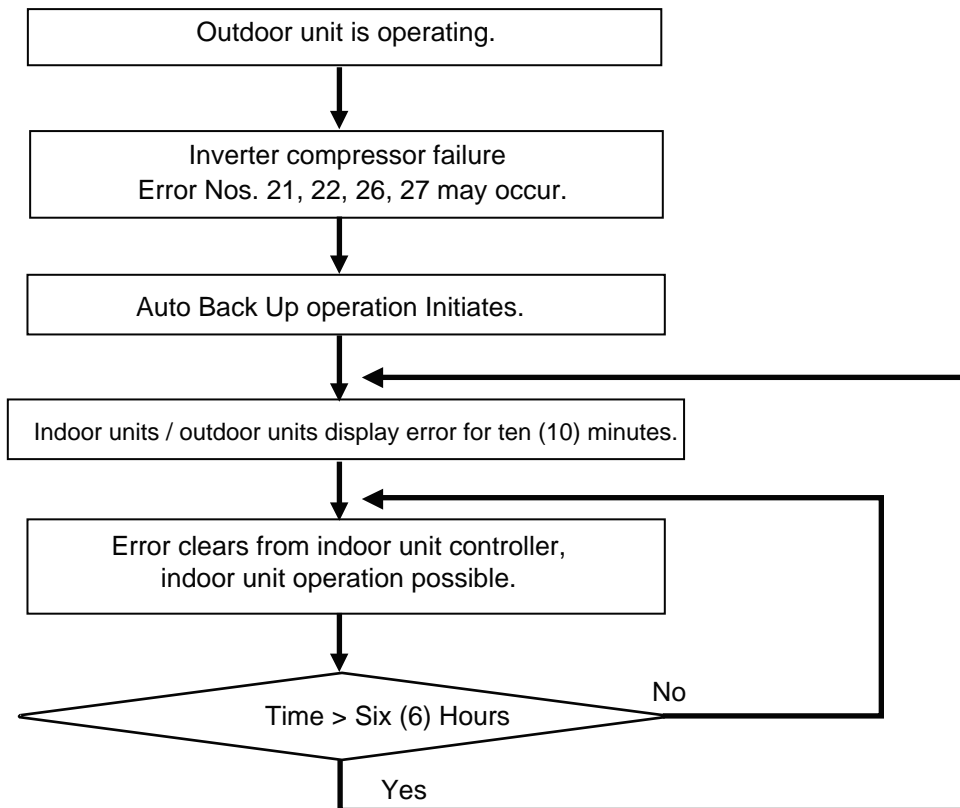

Outdoor Unit Functions

Example: Slave1 Outdoor Unit Inverter Compressor 1 fails (Error No. 21 displays)

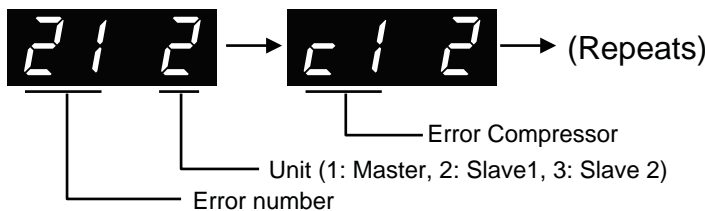

**Note:**

- Request service immediately if error occurs.
- Auto Back Up Function is set up to one (1) inverter compressor.
- When Auto Back Up Function begins, the error code displays for ten (10) minutes every six (6) hours.
- Error will display continuously at the corresponding outdoor unit.

# HEAT RECOVERY UNIT PARTS FUNCTIONS

Table 49: Heat Recovery Unit Parts Table.

Name	Symbol	Function
Low Pressure Vapor Pipe	LPGV	Pipe for Low Pressure Vapor
High Pressure Vapor Pipe	HPGV	Pipe for High Pressure Vapor
Liquid Pipe 1	LP1	Liquid Pipe to the Outdoor Unit(s)
Liquid Bypass Valve	LBV	Prevents Liquid Charge
Solenoid Assembly 1, 2	SOL1, 2	Controls Path for Heating or Cooling
Liquid Pipe 2	LP2	Liquid Pipe to the Indoor Unit(s)
Vapor Pipe	GSP	Vapor Pipe to the Indoor Units
Balancing Valve	BLV	Controls the Pressure Between High and Low Pressure Pipes During Operation Changeover
Subcooling EEV	SCEEV	Controls Subcooling

Figure 39: Heat Recovery Unit Parts Diagram.

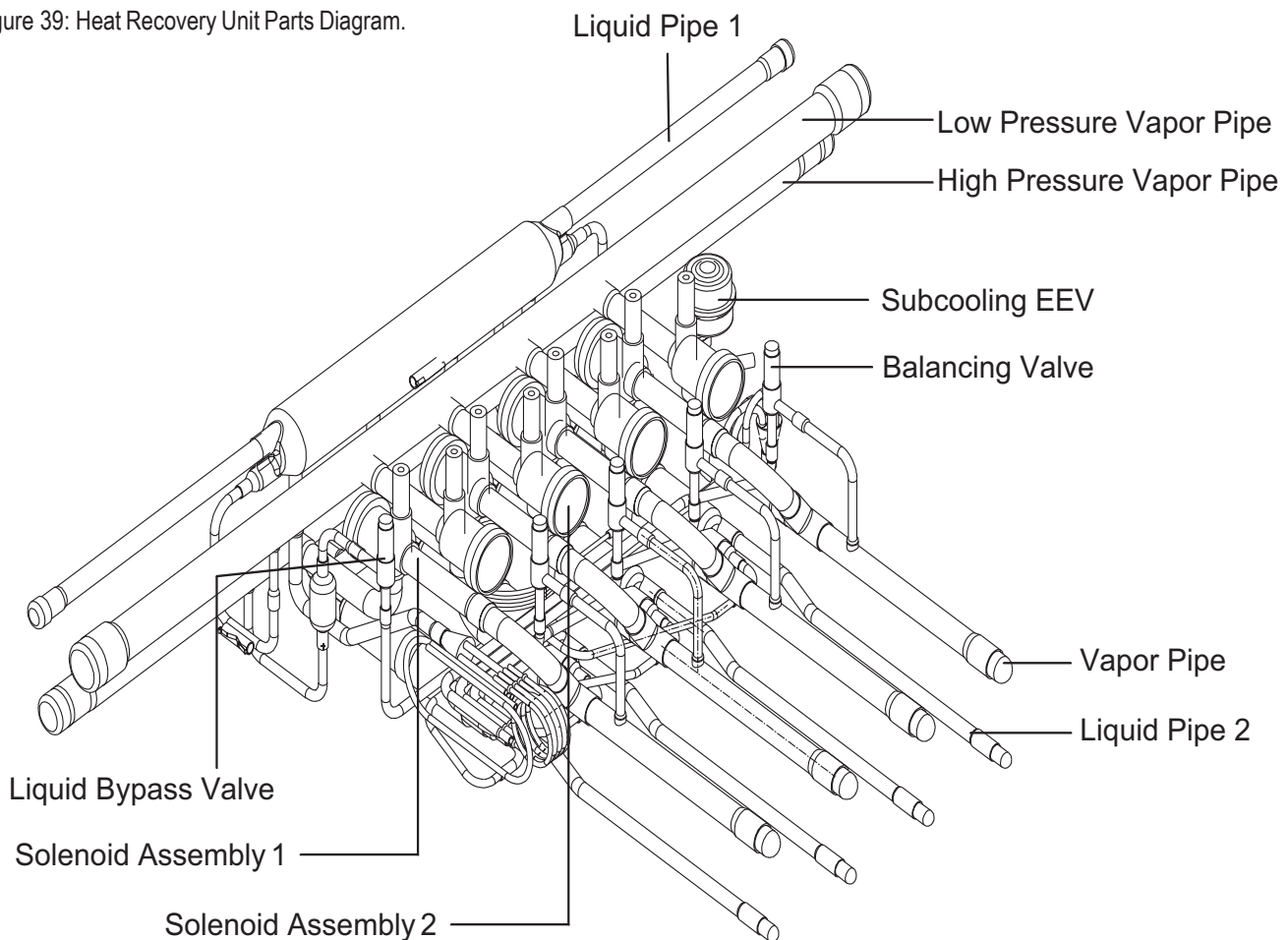

## PRHR022A Heat Recovery Unit

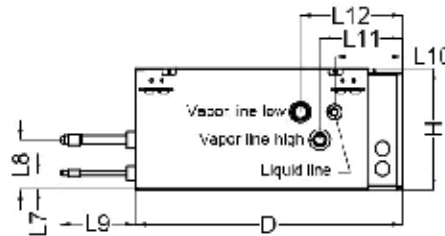
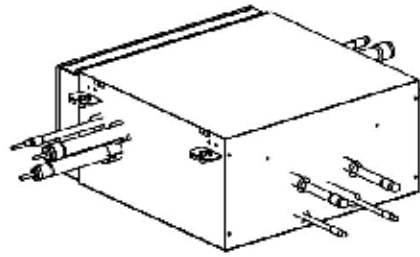
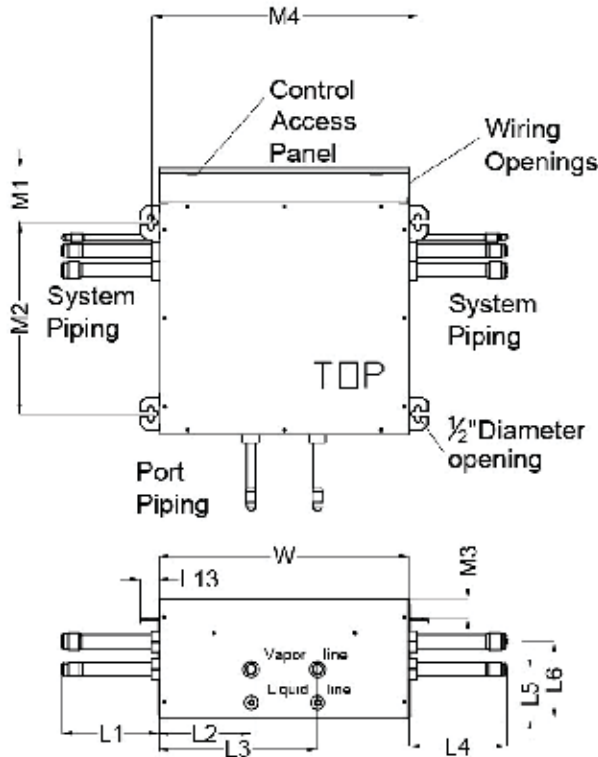

W	17-7/8"
H	8-5/8"
D	18-15/16"
L1	6-7/8"
L2	6-5/8"
L3	11-3/8"
L4	6-7/8"
L5	3-1/2"
L6	5-1/2"
L7	1-3/16"
L8	3-9/16"
L9	5-7/16"
L10	4-3/4"
L11	5-3/4"
L12	7-1/4"
L13	1-1/4"
M1	3-3/4"
M2	13-5/8"
M3	1-1/2"
M4	18-15/16"

Heat Recovery Unit Functions

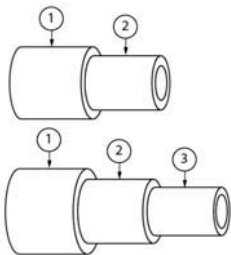

Reducer Dimensions (in)					
		1	2	3	Quantity
Indoor Unit	Liquid Line	3/8 OD	1/4 OD	-	2
	Vapor Line	5/8 OD	1/2 OD	-	2
HR Unit	Liquid Line	3/8 OD	1/4 OD	-	2
	Vapor Line Low	5/8 OD	1/2 OD	-	2
		7/8 OD	3/4 OD	5/8 OD	2
	Vapor Line High	1/2 OD	3/8 OD	-	2
3/4 OD		5/8 OD	1/2 OD	2	

# HEAT RECOVERY UNIT DIMENSIONAL DIAGRAMS

**MULTI V™ 5**

## PRHR032A Heat Recovery Unit

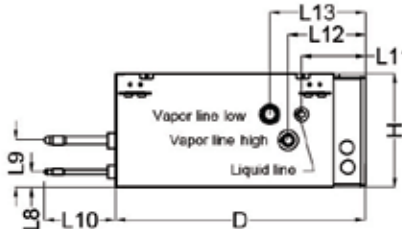
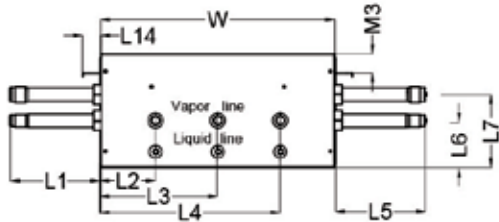
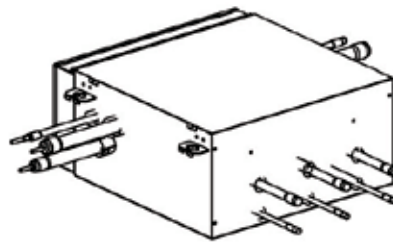
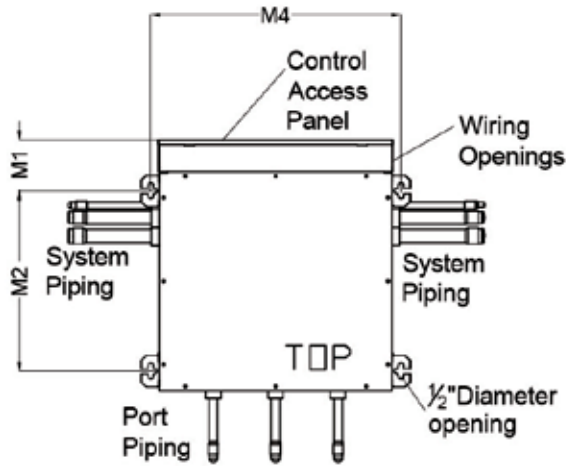

W	17-7/8"
H	8-5/8"
D	18-15/16"
L1	6-7/8"
L2	4-1/4"
L3	9"
L4	13-3/4"
L5	6-7/8"
L6	3-1/2"
L7	5-1/2"
L8	1-3/16"
L9	3-9/16"
L10	5-7/16"
L11	4-3/4"
L12	5-3/4"
L13	7-1/4"
L14	1-1/4"
M1	3-3/4"
M2	13-5/8"
M3	1-1/2"
M4	18-15/16"

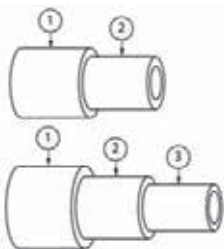

Reducer Dimensions (in)					
		1	2	3	Quantity
Indoor Unit	Liquid Line	3/8 OD	1/4 OD	-	3
	Vapor Line	5/8 OD	1/2 OD	-	3
HR Unit	Liquid Line	1/2 OD	3/8 OD	-	2
	Vapor Line Low	3/4 OD	5/8 OD	-	2
		1-1/8 OD	7/8 OD	3/4 OD	2
	Vapor Line High	5/8 OD	1/2 OD	-	2
7/8 OD		3/4 OD	5/8 OD	2	

## PRHR042A Heat Recovery Unit

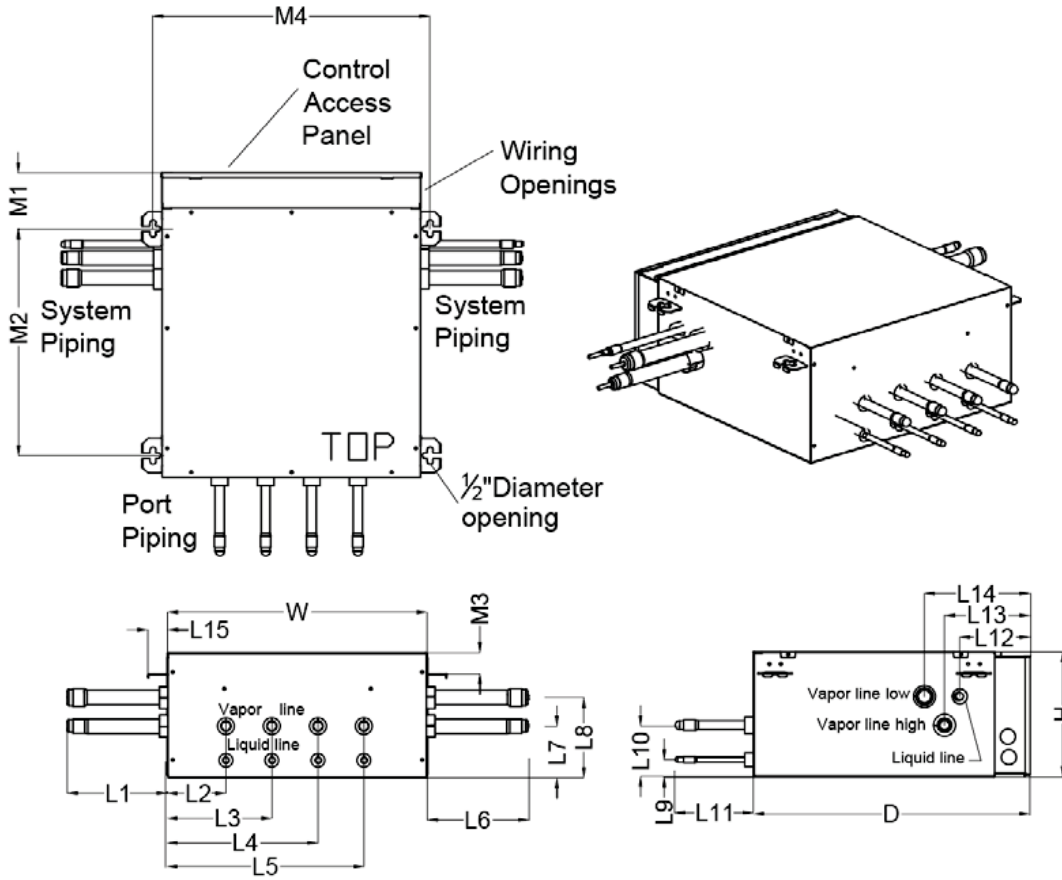

W	17-7/8"
H	8-5/8"
D	18-15/16"
L1	6-7/8"
L2	4-1/4"
L3	7-1/2"
L4	10-1/2"
L5	13-3/4"
L6	6-7/8"
L7	3-1/2"
L8	5-1/2"
L9	1-3/16"
L10	3-9/16"
L11	5-7/16"
L12	4-3/4"
L13	5-3/4"
L14	7-1/4"
L15	1-1/4"
M1	3-3/4"
M2	13-5/8"
M3	1-1/2"
M4	18-15/16"

Heat Recovery Unit Functions

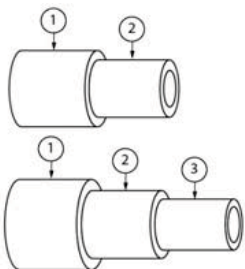

Reducer Dimensions (in)					
		1	2	3	Quantity
Indoor Unit	Liquid Line	3/8 OD	1/4 OD	-	4
	Vapor Line	5/8 OD	1/2 OD	-	4
HR Unit	Liquid Line	1/2 OD	3/8 OD	-	2
	Vapor Line Low	3/4 OD	5/8 OD	-	2
		1-1/8 OD	7/8 OD	3/4 OD	2
	Vapor Line High	5/8 OD	1/2 OD	-	2
7/8 OD		3/4 OD	5/8 OD	2	

# HEAT RECOVERY UNIT WIRING DIAGRAM

**MULTI V™ 5**

PRHR022A, 032A, 042A

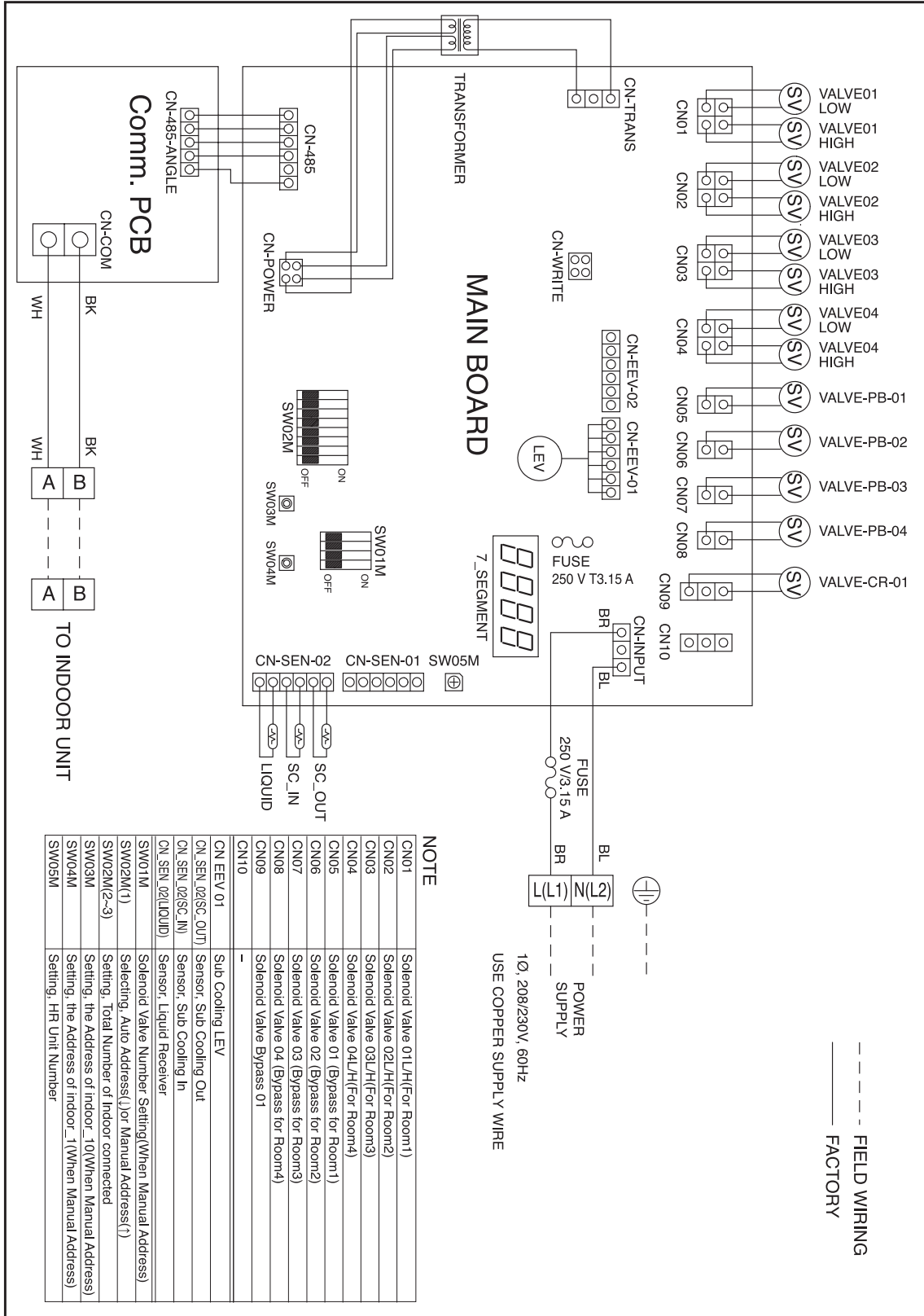

**PRHR022A, 032A, 042A**

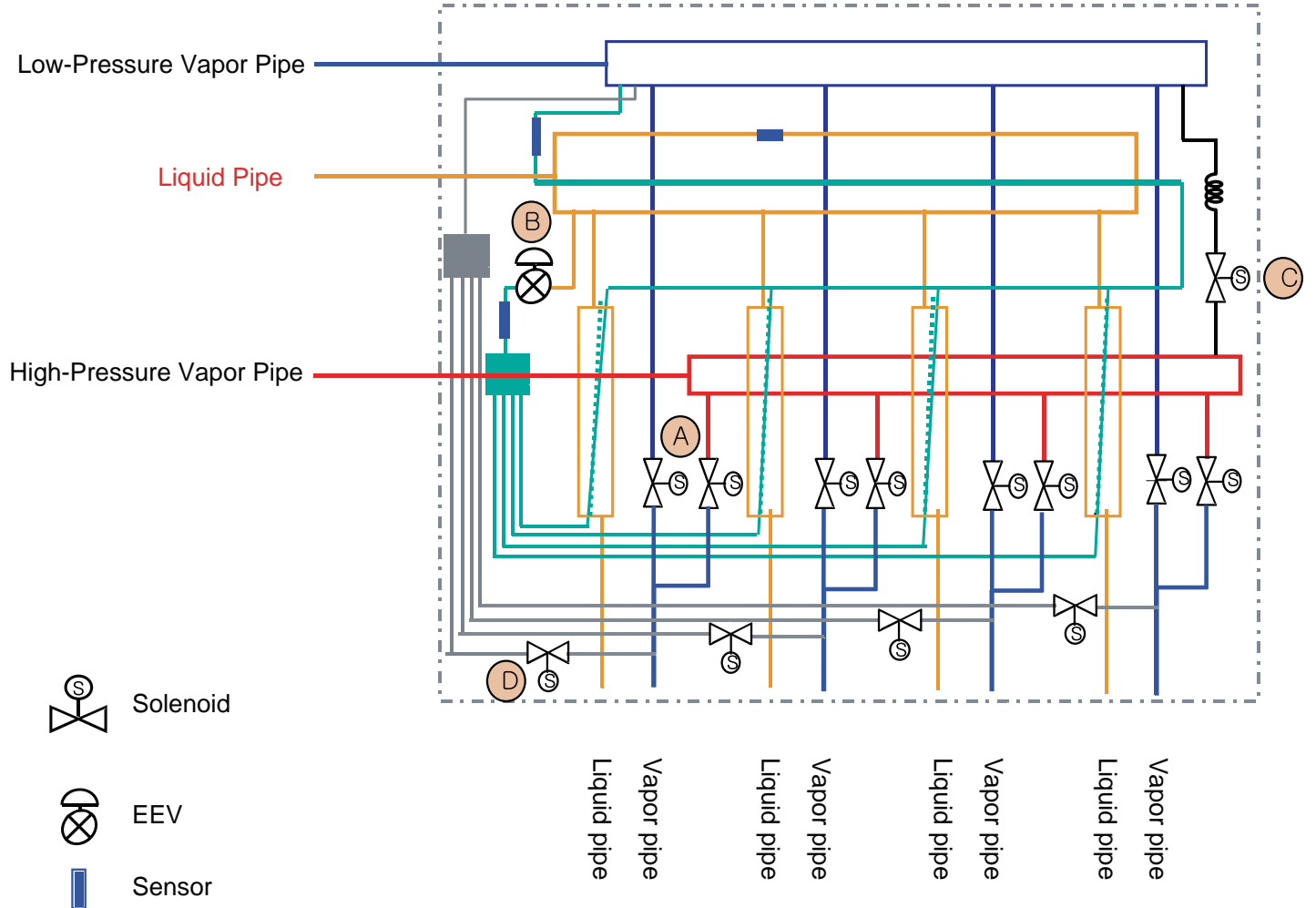

- A : Switches operation between cooling and heating.
- B : Decreases noise following subcooling operation between inlet of one indoor unit and outlet of another indoor unit during simultaneous operation.
- C : Prevents liquid from entering high-pressure vapor valve and heat recovery unit during cooling mode.
- D : Controls pressure between the high and low pressure vapor pipes during simultaneous operation.

## Basic Control

### Normal Operation

Table 50: Normal Operation Functions.

Component	Power On	Cooling Operation	Heating Operation	Stop Operation
High Pressure Vapor Valve	Close	Close	Open	Keep
Low Pressure (Vapor Valve)	Open after thirty (30) seconds	Open	Close	Keep
Liquid Valve	Close	Open	Close	Close

### Start Control (Heating Mode Only)

When the system operates in heating mode, all of the high pressure vapor valves in the heat recovery unit are open.

### Valve Control

See Mode Change Time Calculations in the "Mode Change Time Calculation" table. How the valves are controlled by the Mode Change Time can be seen in the "Valve Control by Mode Change Time" table.

Table 51: Mode Change Time Calculation.

Previous Mode	Change Mode	Mode Change Time
Stop or Ventilation	Cooling or Heating	120 seconds
Cooling	Heating	180 seconds
Heating	Cooling	120 seconds
Cooling or Heating	Stop or Ventilation	During Heating: 60 seconds During Cooling: 0 seconds

### Note:

The time of Mode Change Time will differ based on the software version of the heat recovery unit PCB.

Table 52: Valve Control by Mode Change Time.

Operation Mode	Mode Change Time	High Pressure Vapor Valve	Low Pressure Vapor Valve	Balancing Valve
Cooling	$120 \leq \text{Time}$	Keep	Keep	Close
	$0 < \text{Time} < 120$	Close	Close	Open
	$\text{Time} = 0$	Close	Open	Close
Heating	$180 \leq \text{Time}$	Keep	Keep	Close
	$0 < \text{Time} < 180$	Close	Close	Close
	$\text{Time} = 0$	Open	Close	Close
Stop or Ventilation	$0 < \text{Time} < 5$	Cooling Mode: Close	Keep	Close
	$\text{Time} = 0$	Heating Mode: Low Pressure Vapor Valve → Close	Keep	Close

**Oil Return / Defrost Control**

Table 53: Oil Return / Defrost Control.

Component	Start	During Operation	Stop
Inverter Compressor	Stop	60 Hz	40 Hz
High Pressure Vapor Valve	Keep	Close	Open or Close
Low Pressure Vapor Valve	Keep	Open	Open or Close
Balancing Valve	Open for 30 seconds	Close	Close

**Liquid Bypass Control**

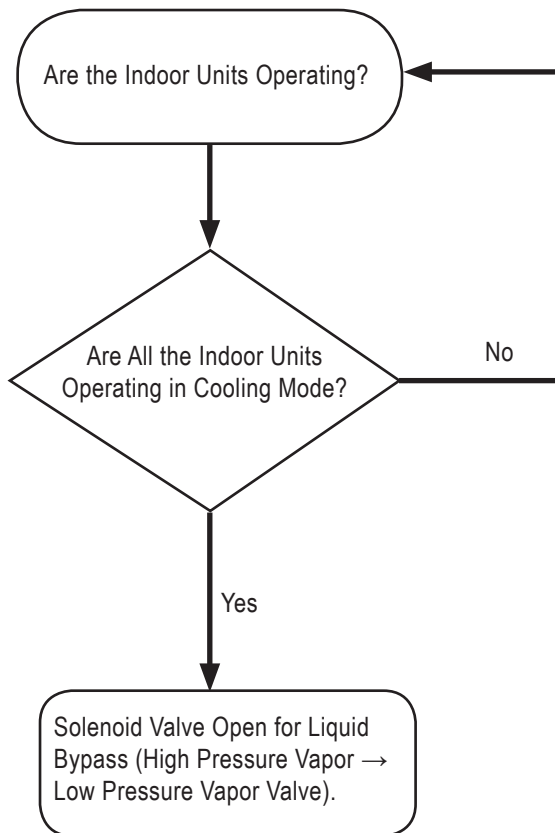

**Subcooling EEV Control**

Subcooling EEV operates with fuzzy logic to keep the degree of subcooling (Target: About 77°F) at the outlet of the subcooler during simultaneous cooling / heating operation.

$$\text{Temperature of Subcooler} = T \text{ Subcooler Outlet} - T \text{ Subcooler Inlet}$$

## Setting Outdoor Units to Heat Pump or Heat Recovery System

Outdoor units are factory set to heat recovery operation—all switches on DIP Switch bank SW01 are set to OFF. All outdoor unit(s) (master and slave[s]) **MUST** be manually set to a heat pump system. To change the factory set heat recovery system to a heat pump system:

- Flip switch No. 4 on the DIP-SW01 bank to ON. Display will show “HR” (heat recovery).
- Push the ► (SW03C) button to change “HR” (heat recovery) to “HP” (heat pump), then press the confirm (SW01C) button.
- Flip switch No. 4 on the DIP-SW01 bank to OFF, and push the reset (SW01D) button to restart the system. If No. 4 on the DIP-SW01 bank is switched to ON again, “HR” (heat recovery) or “HP” (heat pump) can be verified by reading the display later.

Figure 40: Heat Recovery System DIP Switch Setting on Outdoor Units (Factory Set).

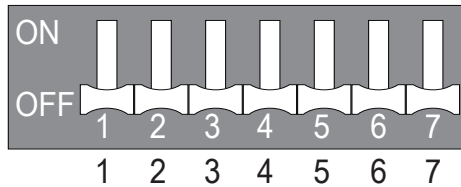
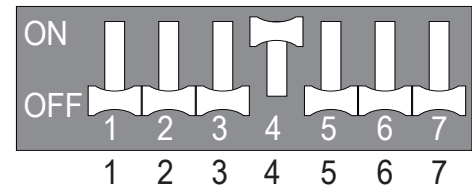

Figure 41: Heat Pump System DIP Switch Setting on Outdoor Units (Manually Set).



## Setting Outdoor Units in Dual / Triple Frame Systems

On the DIP-SW01 bank (Main PCB), one (1) outdoor unit must be set on DIP-SW01 bank to the Master unit and the other units set to the Slave(s) unit(s) or errors will be generated.

- For the DIP-SW01 bank on the master unit, all DIP switches must be set to off.
- For the DIP-SW01 bank on the slave 1 unit, set only DIP switch 6 to ON.
- For the DIP-SW01 bank on the slave 2 unit, set only DIP switch 7 to ON.

Figure 42: Master, Slave1, and Slave2 DIP Switch Settings.

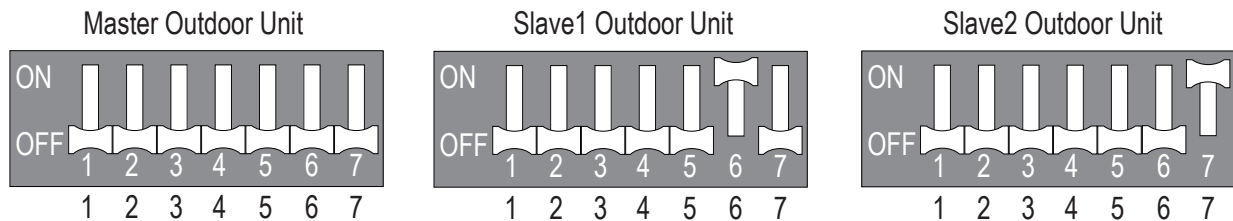

**Addressing with Heat Recovery Units  
(For Heat Recovery Systems Only)**

**General**

Each heat recovery unit will have a unique address assign so the outdoor unit will be able distinguish it from other heat recovery units. Upon completion of the heat recovery unit address, the heat recovery unit operating parameters will be set by adjusting the positions DIP switches on SW02M and SW01M.

**Procedure**

Before beginning the physical process of assigning heat recovery addresses, map out the address assignments using a copy of the LATS tree mode diagram.

**Guidelines**

1. Addresses must be sequential and cannot be skipped.
2. Assign the lowest address to the heat recovery unit that has the largest capacity indoor unit connected to port number 1. If the capacity of all indoor units connected to port number 1 of each heat recovery unit is the same, assign address "0" to the heat recovery unit farthest away from the outdoor unit. Assign the next address to the next farthest away and so on until all heat recovery units have an address. The heat recovery unit with the highest address must be the one closest to the outdoor unit. Up to 16 heat recovery units can be on a single system.

Possible settings in order of lowest to highest are: 0,1,2,3,4,5,6,7,8,9,A,B,C,D,E,F.

**Note:**

*Addressing must be performed following the detailed steps above because port number 1 on the heat recovery unit addressed "0" will remain open during the auto pipe detect procedure. If the indoor unit capacity connected to the port is relatively small compared with other units on the system, the outdoor unit high head pressure safety will trip and shut down the unit during the procedure. On LGMV, all addresses do not match because LGMV does not see address "0".*

3. Record the address assigned to each heat recovery unit.

Figure 43: Heat Recovery Unit Main PCB.

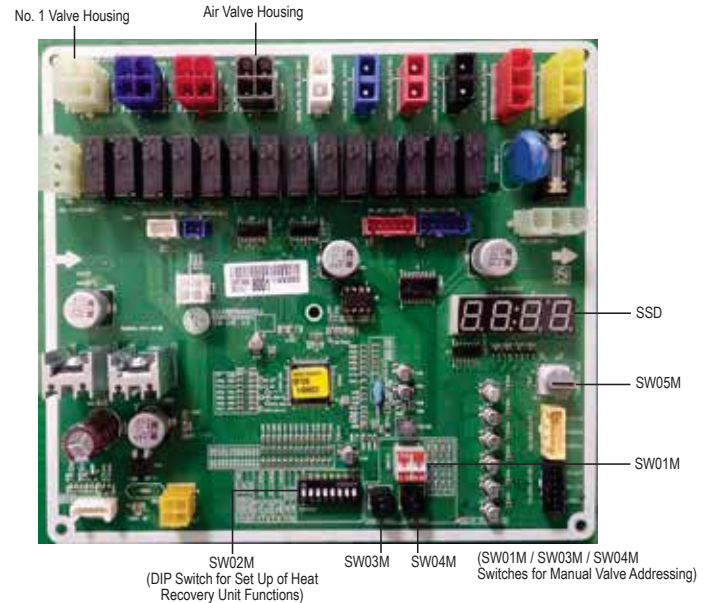
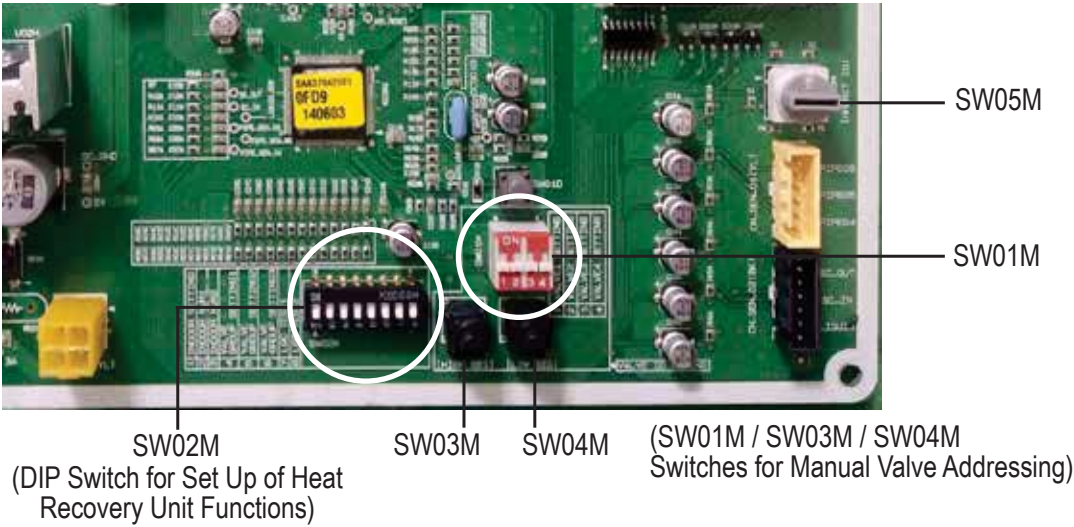

Figure 44: Close Up of DIP Switches and Rotary Dial on the Heat Recovery Unit Main PCB.



MULTI V 5 Outdoor Unit Service Manual

## 1. Main Function of SW02M.

ON S/W	Selection	
	No. 1	Method for addressing the heat recovery control valves (Auto / Manual)
No. 2	Model of heat recovery unit	
No. 3	Model of heat recovery unit	
No. 4	Valve group setting	
No. 5	Valve group setting	
No. 6	Valve group setting	
No. 7	Used only in factory production (preset to "OFF")	Zone setting ("ON")
No. 8	Used only in factory production (preset to "OFF")	

Selecting the Heat Recovery Unit Valve Addressing Method (Pipe Detection) (Auto / Manual).

Auto (Switch No. 1 on SW02M OFF)

Manual (Switch No. 1 on SW02M ON)

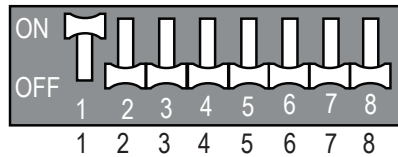
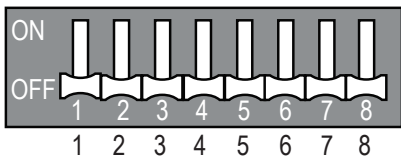

Zone Control Setting.

	DIP Switch Settings	
Normal Control	<p>SW02M</p>	<p>SW01M</p>
Zone Control	<p>SW02M</p>	<p>SW01M</p> <p>Turn the DIP Switch of the zoned branch to ON. Example: Branches one (1) and two (2) are set to zone control.</p>

Select the Heat Recovery Unit Model.

1. Identify how many ports are connected (see table below).
2. Group ports if necessary. If any connected indoor units are "large" capacity models (indoor units with >54,000 Btu/h capacity) two heat recovery ports must be "grouped" to serve a large capacity indoor using an inverted 'Y' branch.
3. Set switches on SW02M as outlined in the table below and on the next page.

Table 54: Selecting the Heat Recovery Unit Model.

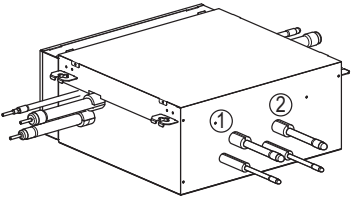
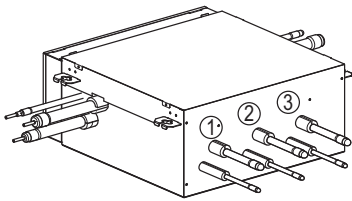
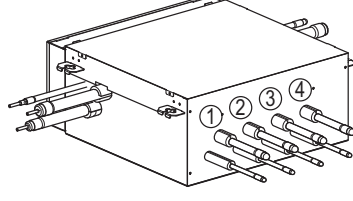
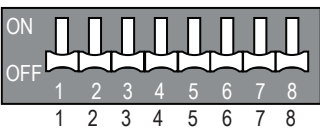
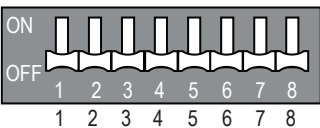
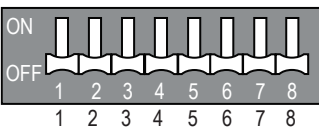
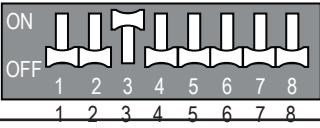
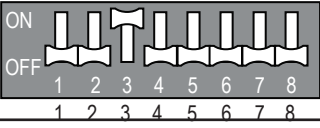
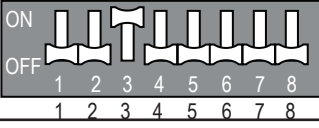
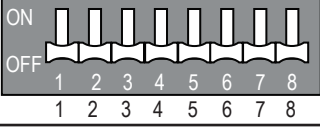
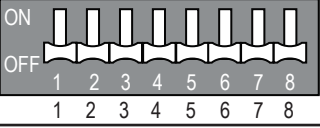
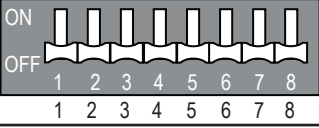
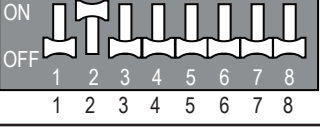
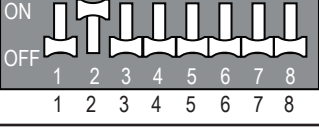
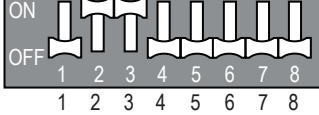
	 PRHR022A (Two [2] ports)	 PRHR032A (Three [3] ports)	 PRHR042A (Four [4] ports)
Factory Setting			
One port connected			
Two ports connected			
Three ports connected			
Four ports connected			

PCB Settings

**Note:**

DIP Switch SW02M bank is factory set to all OFF for all heat recovery units.

- To use a PRHR022A for one port, cap off the second pipe, and set the DIP switches on the heat recovery unit for "one port connected" as shown in the table above.
- To use a PRHR032A for two ports, cap off the third port, and set the DIP switches on the heat recovery unit for "two ports connected" as shown in the table above.
- To use a PRHR042A for three ports, cap off the fourth port, and set the DIP switches on the heat recovery unit for "three ports connected" as shown in the table above.
- To use a PRHR042A for two ports, cap off the third and fourth ports, and set the DIP switches on the heat recovery unit for "two ports connected" as shown in the table above.
- Any unused port must be sealed with a brazed copper cap,  not with a plastic cap.

Select the Valve Group.

Table 55: SW02M Valve Group Settings.

	DIP Switch Setting	Example
No Valve Group Control		<p>Indoor unit Indoor unit Indoor unit Indoor unit</p>
No. 1, 2 Valve Control		<p>Indoor unit Indoor unit Large capacity indoor unit</p>
No. 2, 3 Valve Control		<p>Indoor unit Large capacity indoor unit Indoor unit</p>
No. 3, 4 Valve Control		<p>Large capacity indoor unit Indoor unit Indoor unit</p>
No. 1, 2 Valve Control No. 3, 4 Valve Control		<p>Large capacity indoor unit Large capacity indoor unit</p>

MULTI V 5 Outdoor Unit Service Manual

**Note:**

If large capacity indoor units (larger than 54,000 Btu/h) are installed, the Y-branch pipe shown in the table below must be used to twin the ports.

Kit Model No.	Vapor Pipe Dimensions	Vapor Pipe Model No.	Liquid Pipe Dimensions	Liquid Pipe Model No.
ARBLN03321		AJR54072906		AJR54072902

**2. SW05M Function (Rotary Switch for Addressing Heat Recovery Units).**

• Rotary switch SW05M must be set to "0" when installing only one heat recovery unit. **Figure 45: Adjusting the Heat Recovery Unit Addresses.**

• When installing multiple heat recovery units, address each unit with sequentially increasing numbers starting from "0".

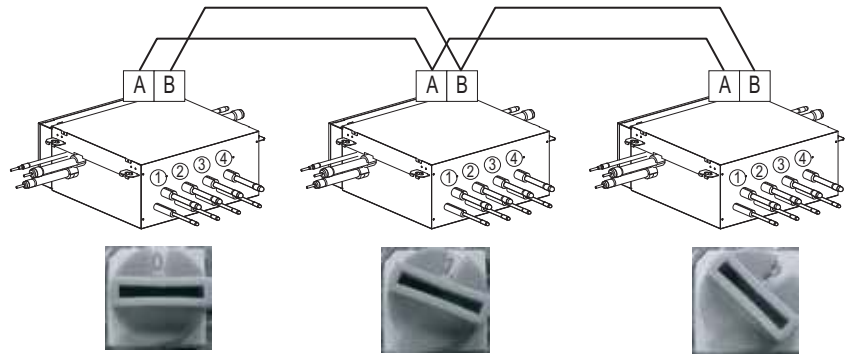

PCB Settings

**3. SW01M / SW03M / SW04M (DIP and Tact Switches) for Manual Valve Addressing**

Non-zoning (Normal Setting).

- Set the address of the heat recovery unit valve to the central control address of the connected indoor unit.
- SW01M: Select the valve to address.
- SW03M: Increases the valve address by ten (10).
- SW04M: Increases the valve address by one (1).

**Note:**

Each indoor unit must have a unique, preset central control address (using its wired controller) before manual valve addressing can occur.

Table 56: Settings for Manual Valve Addressing, Non-Zoning.

PCB Component	S/W No.	Set Up
	No. 1	Manual Addressing Valve No. 1
	No. 2	Manual Addressing Valve No. 2
	No. 3	Manual Addressing Valve No. 3
	No. 4	Manual Addressing Valve No. 4
	SW03M	Increases the Valve Address by Ten (10)
	SW04M	Increases the Valve Address by One (1)

## 3. SW01M / SW03M / SW04M (DIP and Tact Switches) for Manual Valve Addressing, continued.

### Zoning

- Set the address of the heat recovery unit valve to the central control address of the connected indoor unit.
- SW01M: Select the valve to address.
- SW03M: Increases the valve address by ten (10).
- SW04M: Increases the valve address by one (1).
- SW05M: Rotary switch

### Note:

- Indoor units must be addressed first with a central control address.
- Each indoor unit must have a unique, preset central control address (using its wired controller) before manual valve addressing can occur.

Table 57: Settings for Manual Valve Addressing, Zoning.

PCB Component	S/W No.	Set Up
	No. 1	Manual Addressing Valve No. 1
	No. 2	Manual Addressing Valve No. 2
	No. 3	Manual Addressing Valve No. 3
	No. 4	Manual Addressing Valve No. 4
	SW03M	Increases the Valve Address by Ten (10)
	SW04M	Increases the Valve Address by One (1)
	SW05M	Manual Addressing of Zoned Indoor Units

## Indoor Unit Auto Addressing Procedure

### ⚠ WARNING

Disconnects must only be operated by a properly licensed electrician at this time. ⚡ Never look at a disconnect switch when closing. Turn away from the switch when closing. Incorrect wiring could cause the disconnect to explode, physical injury, and / or death.

### Note:

- Supply power to the indoor units. If power is not supplied, an operation error will occur.
- See Error No. CH200 will appear when the auto addressing procedure has failed. See the Troubleshooting section for information on how to resolve Error No. CH200.
- During the pre-commissioning process for systems with Gen 4 indoor units, ⚡ do not change any DIP switch settings except for No. 3 on SW01B, which must be ON to enable Gen. 4 features. All other combinations of switches (one [1] through seven [7]) must be left in the OFF position on the outdoor unit DIP switch bank SW01B.
- If the Auto Address Procedure has never been successfully completed for the system, the compressor(s) will not start when power is applied to the unit.
- Auto addressing is only possible on the main PCB of the outdoor unit (master unit if dual / triple frame system).
- If an indoor unit PCB has been replaced, the auto addressing procedure must be performed again.

1. Verify all that all indoor units connected to the system have power to the PCB board AND all wired controller system start buttons are OFF.
2. Remove the maintenance access panel and unit control box cover from the outdoor unit. Place panels and screws in a secure area.
3. Verify that the communications cable between the indoor units and the outdoor unit is terminated at the outdoor unit terminals IDU(A) and IDU (B).
4. Verify the shield on the communications cable is grounded at the outdoor unit. The shields must be tied together and taped back.
5. If installing a dual- or triple-frame system, verify which outdoor unit will be the "Master" unit, the Slave1 unit, and the Slave2 unit; check if the DIP switches on DIP-SW01 are set properly. (See "Setting Outdoor Units in Dual / Triple Frame Systems" earlier in this section.)
6. Cycle power on the outdoor units, indoor units, etc., and wait three (3) minutes while the outdoor unit sequences through the self-diagnostics check, and to improve indoor unit communication when initial power is supplied. Leave disconnect in the "ON" position.
7. Check the outdoor unit(s) current configuration code(s). Observe the unit setup codes using the SSD display found on the outdoor units PCB.

### Note:

After the self-diagnostics check is complete, the SSD is clear with nothing displayed. Diagnostic process takes from three (3) to seven (7) minutes.

8. Know how many indoor units are connected to the system.
9. Press and hold the red SW01C button for about five (5) seconds. Release when "88" appears on the SSD of the master outdoor unit PCB. After three (3) to seven (7) minutes, the display will flash a number for about thirty (30) seconds, indicating how many total indoor units the system successfully communicated with.
10. This number must match the known installed number of indoor units if the auto addressing procedure was successful. If using LGMV, read the address of each indoor unit. The address of each indoor unit is also indicated on wired remote control displays.
11. Upon completion of the auto addressing routine, the display will be blank and the system will be in standby waiting for another command.
12. Upon successful completion of the auto address procedure, record the system address assigned to each indoor unit by the auto address procedure.

Figure 46: Auto Addressing Button Location on Outdoor Unit PCB.

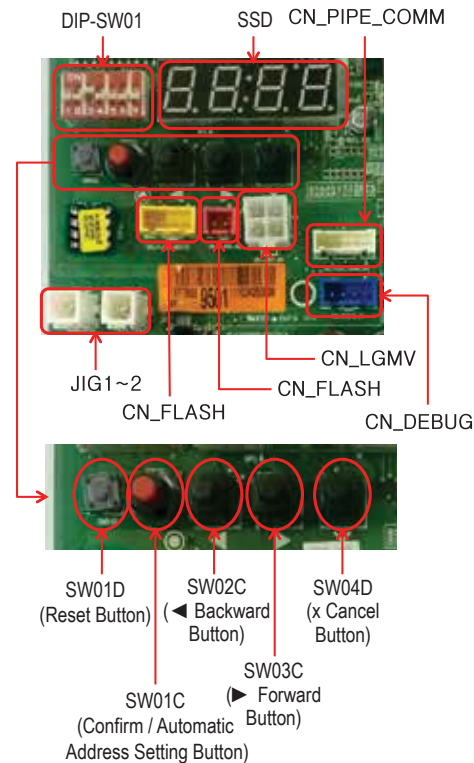
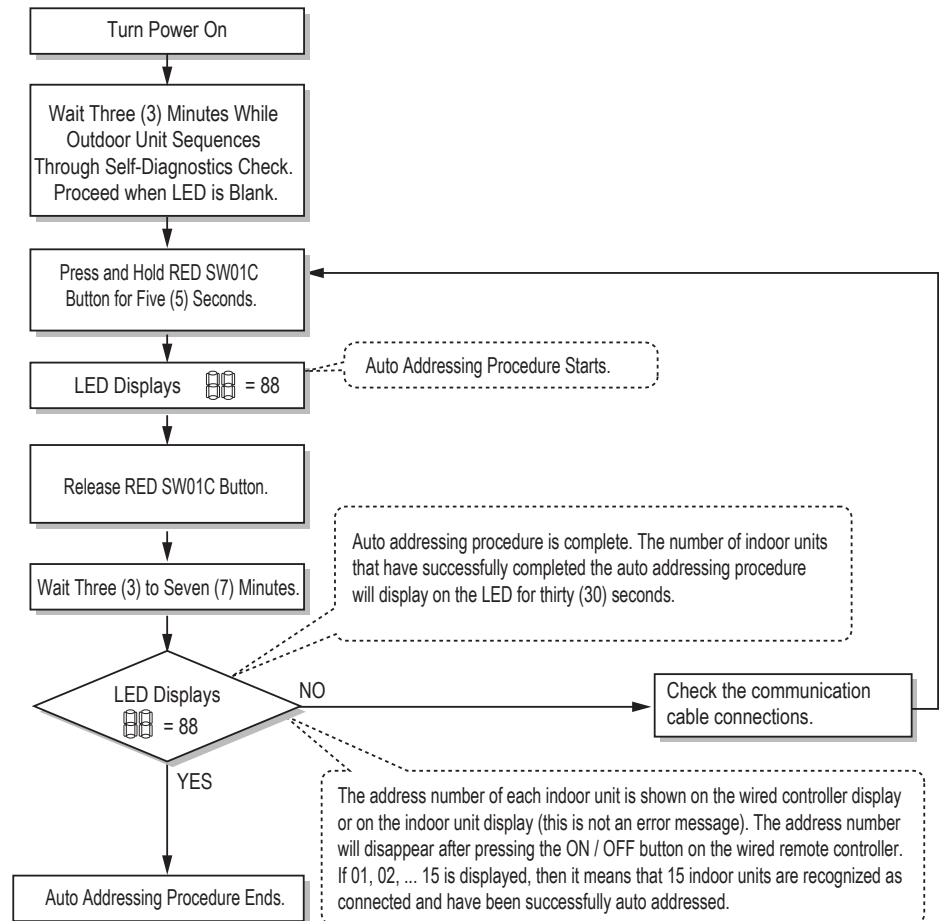

Figure 47: Auto Addressing Flowchart.



## Troubleshooting a Failed Indoor Unit Auto Addressing Procedure

If the quantity of indoor units the auto addressing procedure found is incorrect, or the “88” never disappears from the display for the seven (7) minutes, the auto address procedure has failed and a communications problem exists. If the Auto Address Procedure failed:

1. Verify ALL indoor unit ON/OFF buttons are in the OFF position (i.e., ON / OFF button NOT illuminated).
2. Check the terminations, polarity, and continuity of each conductor on the communications cable between the outdoor unit and the indoor units. Verify the indoor unit to outdoor unit communications cable is wired correctly.
3. Verify the shield of the communications cable is grounded at the outdoor unit only. All segment shields must be spliced together at each indoor unit and  $\text{⊕}$  NOT grounded.
4. After repairing the communications cable, go to Step 9 of the Auto Addressing Procedure and repeat the process until successful: Press and hold the red SW01C button for about five (5) seconds. Release when “88” appears on the SSD. After three (3) to seven (7) minutes, the display will flash a number for about thirty (30) seconds indicating how many total indoor units the system successfully communicated with.
5. This number must match the known installed number of indoor units if the auto addressing procedure was successful.
6. Upon completion of the auto addressing routine, the display will be blank and the system will be in standby waiting for another command.
7. Record the system address the outdoor unit assigned to each indoor unit by the auto address procedure.

## Auto Addressing for Pipe Detection

Auto addressing for pipe detection function sets the connection relationship automatically between the indoor units and the heat recovery units.

1. Turn No.1 of SW02M on the heat recovery unit PCB to OFF.
2. Confirm that the setting of Nos. 2, 3 of SW02M corresponds with the number ports used.
3. Reset the power of heat recovery unit PCB.  
Turn master outdoor unit PCB No. 5 DIP switch to ON.
4. Select the "Idu" mode using ► and ◀, then push the ● button.
5. Select the "Id 5" "Ath" or "Atc" function using ► and ◀, then push the ● button. If outdoor temperature is >59°F, use "Ath". If that does not work, use "Atc." If outdoor temperature is <59°F, use "Atc". If that does not work, use "Ath."

### Note:

*Atc = "At-cold outside", and Ath = "At-hot outside". Select accordingly.*

6. Select the "Idu" mode using ► and ◀, then push the ● button.
7. Select the "Id 6 StA" function using ► and ◀, then push the ● button.
8. The number "88" is displayed on the SSD of the outdoor unit main PCB. If the display shows -----, then wait longer.
9. The automatic pipe detection procedure starts.
10. The procedure will run from five (5) to sixty (60) minutes, depending on the number of connected indoor units, and the ambient outdoor temperature.
11. The number of indoor units detected is displayed for thirty (30) seconds to one (1) minute on the outdoor unit PCB after the outdoor unit stops.
  - The number of indoor units connected to each heat recovery unit will be displayed.
  - If there is an auto pipe detection error, "200" will be displayed. .

### Note:

- Run the auto addressing and auto pipe detection procedures again whenever an indoor unit PCB and / or and heat recovery unit PCB are replaced. Apply power to the indoor units and heat recovery units after the repair is complete, otherwise operation errors will occur.
- Error No. 200 occurs if the number of actual connected indoor units and the number of detected indoor units are different.
- If the auto pipe detection procedure fails, perform the manual pipe detection procedure. (If the auto pipe detection procedure is successful, the manual pipe detection procedure is not required.)
- The auto pipe detection procedure can be run again after a failed auto pipe detection procedure attempt; just reset the outdoor unit first.
- ⓧ Do not turn off the main unit PCB for at least five (5) minutes after the auto pipe detection procedure is complete; allow time for the outdoor unit to automatically save auto pipe detection results.

Figure 48: Auto Addressing for Pipe Detection Procedure Flowchart.

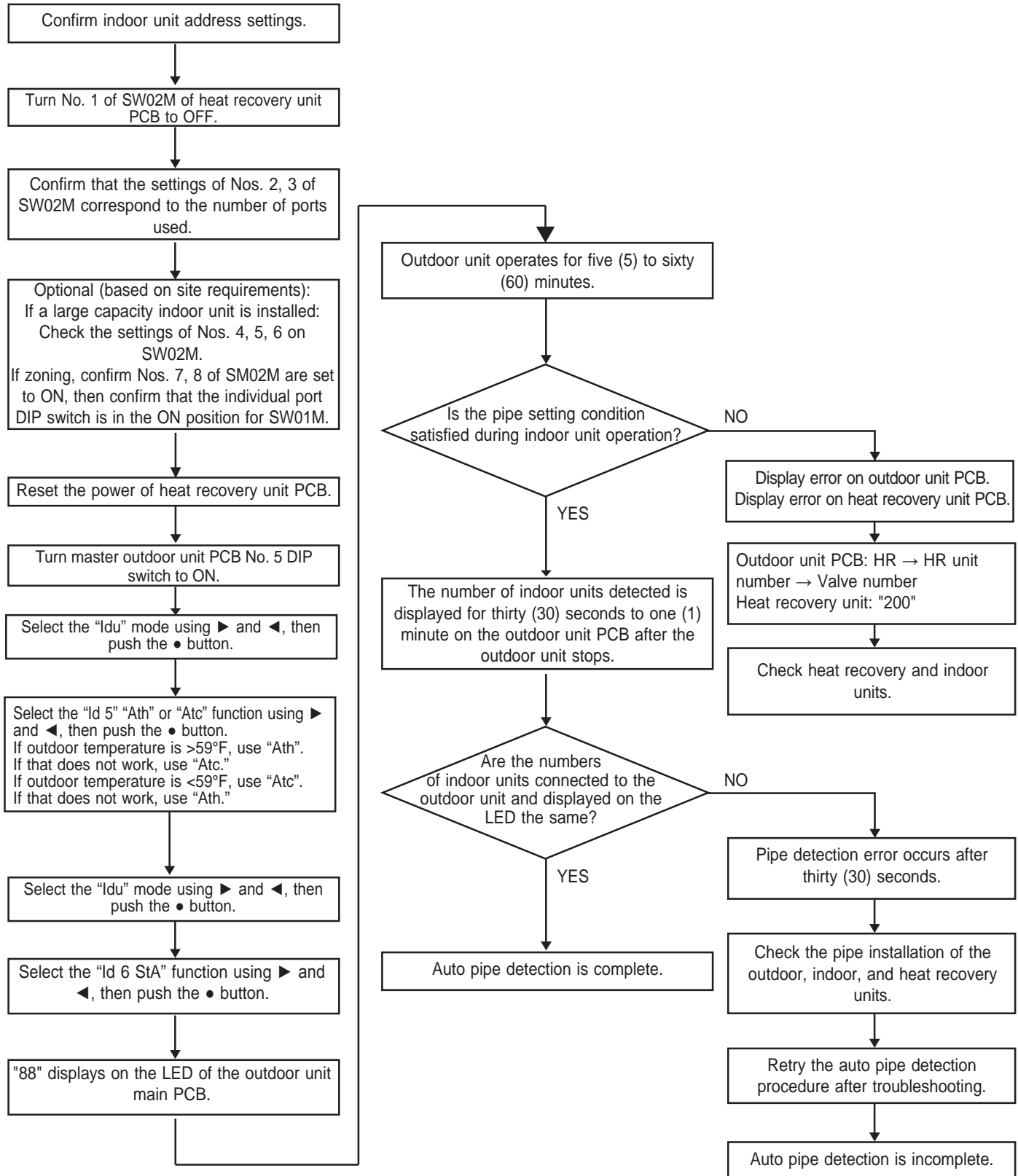

## Manual Addressing for Pipe Detection

1. Enter the central control address into each indoor unit using its wired remote control. If a controller is not available, a controller needs to be added.
2. Turn No. 1 of DIP switch bank SW02M of the heat recovery unit PCB ON.
3. Reset the power of the heat recovery unit PCB.
4. Through the heat recovery unit PCB, manually set address of each heat recovery unit valve to the central control address of the indoor unit connected to that valve.
5. Reset the power to the outdoor unit PCB.
6. The number of the indoor unit installed will be displayed after about five (5) minutes. (Example: Heat Recovery Unit to the Number of the Indoor Unit.)
7. Reset the power of the outdoor unit PCB and the heat recovery unit.
8. Manual pipe detection addressing is complete.

Figure 50: Location of DIP Switch SW02M on the Heat Recovery Unit Main PCB.

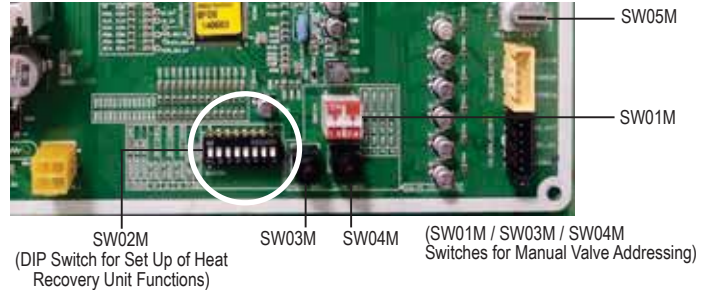
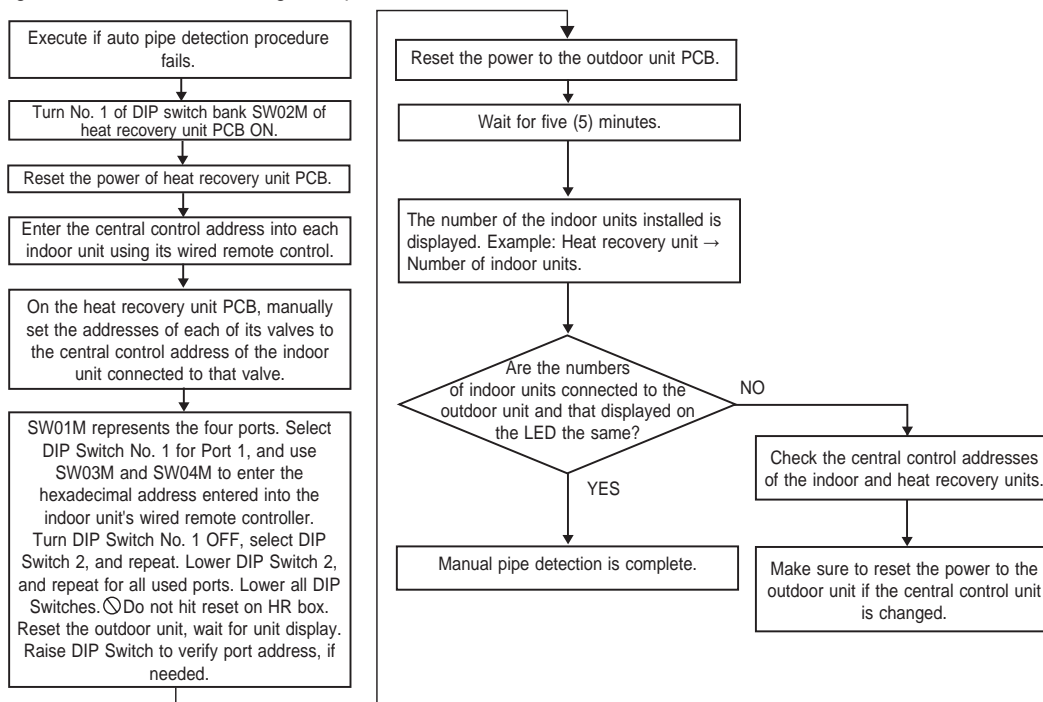

Figure 49: Manual Addressing for Pipe Detection Flowchart.



### Note:

1. If a central controller is not installed yet, leave the address data alone until the installer adds the central controller, and sets the central control address as desired.
2. If a central controller is already installed, the wired remote controller of the indoor units will provide the central control addresses. (In this case, manually set the heat recovery unit pipe address following the central control address of the indoor unit.)
3. Central controller addresses must be set manually at each individual controller.
4. A pipe that does not have an indoor unit connected to it must be set with a different address than a pipe that does have an indoor unit connected to it. (If addresses are the same, the valves will not operate.)
5. Change the manual pipe settings using the heat recovery unit PCB.
6. An error indicates that the manual pipe detection procedure was not completed properly.
7. To save the pipe detection procedure results automatically, do not turn off the main outdoor unit PCB for five (5) minutes after the procedure has finished.

## Manual Addressing for Pipe Detection Example (Non-Zone Setting)

Before performing manual pipe addressing, input a different central control address to every indoor unit through either a wired or a wireless controller (depending on indoor unit type).

Example: An indoor unit with a central control address of "11" is connected to valve "1" of a heat recovery unit.

No.	Display / Setup	Description
1	SSD                      SW01M                      SW03M                      SW04M	Operation: None Display: None
2	SSD                      SW01M                      SW03M                      SW04M	Operation: Turn DIP switch No. 1 on to address valve No. 1 (SW01M). Display: Existing value saved in EEPROM is displayed on SSD.
3	SSD                      SW01M                      SW03M                      SW04M	<ul style="list-style-type: none"> <li>Operation: Set the "10" digit of the Group High data number of the wired remote control connected to the corresponding indoor unit to the valve No. 1 by pressing left tact switch (SW03M).</li> <li>Display: Digit increases with the number of times the tact switch is pressed, shown on the SSD.</li> </ul>
4	SSD                      SW01M                      SW03M                      SW04M	<ul style="list-style-type: none"> <li>Operation: Set the "1" digit of the Group Low data number of the wired remote control connected to the corresponding indoor unit to the valve No. 1 by pressing right tact switch (SW04M).</li> <li>Display: Digit increases with the number of times the tact switch is pressed; shown on right SSD numeral.</li> </ul>
5	SSD                      SW01M                      SW03M                      SW04M	<ul style="list-style-type: none"> <li>Operation: Turn DIP switch No. 1 off to save the address of valve No. 1 (SW01M).</li> <li>Display: "11" displayed on SSD disappears.</li> </ul>

### Note:











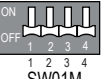



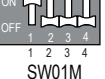



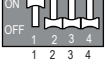



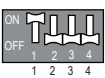



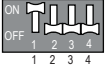

- The procedure described above must be performed for all heat recovery unit valves.
- Valves that do not have indoor units connected to them must be addressed with a number that has not been used. (Valves will not work if the address numbers are the same.)

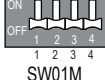
**Manual Addressing for Pipe Detection Example (Zone Setting)**

Zone control is when two (2) or more indoor units are connected to one (1) valve of the heat recovery unit. For this application, set the controls with the multiple indoor connections using the rotary switch; i.e., only the rotary switch changes the same valve set condition and set indoor units connection.

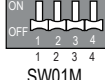
1. Set the DIP switch on the corresponding valves and the rotary switch to "0".
2. Set the number using the tact switches.
3. If additional indoor units are connected to one heat recovery unit valve, increase the rotary switch setting by one (1) and set the number using the tact switches.
4. To verify the number of the corresponding valve, turn the DIP switch to ON and set the number on the rotary switch.
5. One heat recovery unit valve can support up to eight (8) indoor units (rotary switch settings 0~7). An error will display if more than eight (8) indoor units per heat recovery valve are set with the rotary switch.
6. Return the rotary switch to its original setting (heat recovery unit number settings) after all pipe settings are complete.
7. The rotary switch setting value of the number of indoor units connected to "FF" prevents a malfunction. Example: Where three (3) indoor units are connected to valve 1; rotary switch settings are 0,1,2 and 3,4,5,6,7 with "FF". (Prerequisite for manual pipe detection: The central control address of each indoor unit must be preset differently using its wired remote control.)

Example: An indoor unit with a central control address of "11" is connected to valve no. "1" of an heat recovery unit.

No.	Display / Setup	Description
1	 LED  SW01M  SW03M  SW04M  SW05M	Operation: None Display: None
2	 SSD  SW01M  SW03M  SW04M  SW05M	Operation: Turn DIP switch No. 1 on to address valve No. 1. Display: Existing value saved in EEPROM is displayed on SSD.
3	 SSD  SW01M  SW03M  SW04M  SW05M	<ul style="list-style-type: none"> <li>• Operation: Set the "10" digit to the number in Group High data of the wired remote control connected to the corresponding indoor unit with the valve No. 1 by pressing left tact switch.</li> <li>• Display: Digit increases with the number of times the tact switch is pressed, shown on left SSD.</li> </ul>
4	 SSD  SW01M  SW03M  SW04M  SW05M	<ul style="list-style-type: none"> <li>• Operation: Set SW05M to "1".</li> <li>• Display: Former set value is shown on SSD.</li> </ul>
5	 SSD  SW01M  SW03M  SW04M  SW05M	<ul style="list-style-type: none"> <li>• Operation: Set SW03M, SW04M, and SW05M to "1".</li> <li>• Display: Set value is shown on SSD.</li> </ul>
6	 SSD  SW01M  SW03M  SW04M  SW05M	<ul style="list-style-type: none"> <li>• Operation: Turn DIP switch No.1 to off to save the address of valve No. 1.</li> <li>• Display : Set value from previous step disappears; SSD is blank.</li> </ul>
7	 SSD  SW01M  SW03M  SW04M  SW05M	<ul style="list-style-type: none"> <li>• Operation: Addressing the return valve of the heat recovery unit.</li> <li>• Display: SSD is blank.</li> </ul>

**Note:**

- The procedure described above must be performed for all heat recovery unit valves.
- Valves that do not have connected indoor units must be addressed with a number that has not been used. (Valves will not work if the address numbers are the same.)

## Example of Checking the Valve Address

Example: An indoor unit with a central control address of "11" is connected to heat recovery unit valve No. 1.

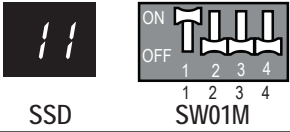
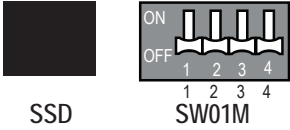
No.	Display / Setup	Description
1	 <p>SSD</p> <p>SW01M</p>	<ul style="list-style-type: none"> <li>• Operation: Turn DIP switch No. 1 to ON.</li> <li>• Display: "11" displays on SSD.</li> </ul>
2	 <p>SSD</p> <p>SW01M</p>	<ul style="list-style-type: none"> <li>• Operation: Turn DIP switch No. 1 to OFF.</li> <li>• Display: SSD is blank.</li> </ul>

## Identifying the Manual Valve Address

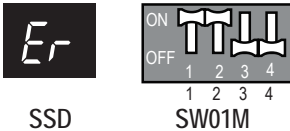
No.	Display / Setup	Description
1	 <p>SSD</p> <p>SW01M</p>	<ul style="list-style-type: none"> <li>• Operation: More than two (2) DIP switches turned ON.</li> <li>• Display: SSD displays "Er."</li> </ul>

### Note:

- Wait for eighty (80) seconds after power is turned ON.
- Zoning and master indoor unit information are removed from EEPROM after auto addressing.
- If a central control is installed, it is impossible to set the master indoor unit in zoning.

Be aware of the following safety precautions when troubleshooting the main components.

**⚠ DANGER**

- High voltage electricity is required to operate this system. Adhere to the NEC code and these instructions when wiring. Improper connections and inadequate grounding can cause accidental injury or death.
- Turn the power off before servicing the equipment. Electrical shock can cause physical injury or death.
- ⓧ Do not operate the disconnect switch with wet hands. There is risk of fire, electric shock, physical injury or death.

**⚠ WARNING**

- Disconnects must only be performed by a properly licensed electrician. Incorrect wiring could cause the disconnect to explode, leading to physical injury or death.
- ⓧ Do not supply power to the unit until all electrical wiring and controls wiring are completed. There is risk of fire, electric shock, physical injury or death.
- ⓧ Do not operate the unit with the panel(s) or protective cover(s) removed; keep fingers and clothing away from moving parts. The rotating, hot, cold, and high-voltage parts of the unit can cause physical injury or death.
- ⓧ Do not touch the refrigerant piping during or after operation. It can cause burns or frostbite.

**Note:**

- ⓧ Do not supply power to the unit until all electrical wiring and controls wiring are completely installed. The system will malfunction.
- If the power wiring and communication cables are not properly connected (connections switched), the communication components will burn out and the system will not operate.

**Test Run Checklist**

Table 58: Test Run Checklist.

1	<p>Check for any refrigerant leaks in the piping system.</p> <p>Verify that all power wiring and communication cables are properly connected. Check for disconnected and loose power wiring and communication cables connections.</p>
2	<p>Measure the insulation resistance between the power supply terminal block and ground using a mega-tester device (DC 500V). Resistance must be <math>\geq 2.0 \text{ M}\Omega</math>; if the resistance is <math>&lt; 2.0 \text{ M}\Omega</math>, ⓧ do not operate the unit.</p> <p><b>Note:</b></p> <ul style="list-style-type: none"> <li>• ⓧ Never perform the megaohm check on the terminal control board. This will damage the control board.</li> <li>• Immediately after installation, or if the system is off for a long period, refrigerant can accumulate in the compressor, which can cause the insulation resistance between the power supply terminal board and the ground to drop <math>&lt; 2.0 \text{ M}\Omega</math>. If the insulation resistance is <math>&lt; 2.0 \text{ M}\Omega</math>, the power is turned on, and the compressor crankcase heater operates for <math>\geq</math> six (6) hours, the refrigerant evaporates, which will cause the insulation resistance to increase.</li> </ul>
3	<p>For Heat Recovery Systems: Check if the liquid, high pressure vapor, and low pressure vapor piping valves are fully opened.</p> <p>For Heat Pump Systems: Check if the liquid and vapor piping valves are fully opened. Verify that the valve for the middle piping (not used for heat pump systems) is completely closed.</p> <div style="display: flex; justify-content: space-around; align-items: flex-start;"> <div style="text-align: center;"> <p>Heat Recovery Systems</p> </div> <div style="text-align: center;"> <p>Heat Pump Systems</p> </div> </div> <p><b>Note:</b></p> <p>Tighten all caps on the liquid and gas (vapor) service valves.</p>
4	<ul style="list-style-type: none"> <li>• Check for any problems in the automatic addressing.</li> <li>• Check / confirm that there are no error messages displayed on the indoor units, wired controllers, or the outdoor unit(s) SSD(s).</li> </ul>

## Test Run Checklist, continued.

### Note:

- Main power to the outdoor unit must always remain on during the cooling and heating seasons.
- Apply power after installation, and before performing the test run.
- Always apply power for six (6) hours to heat the crankcase heater before operating the system. The compressor will burn out if the crankcase heater is not preheated for at least six (6) hours. The compressor will also be damaged if the crankcase heater has not preheated for at least six (6) hours, and the system operates when the outdoor temperature is below 50°F).

## Main Component Errors

Table 59: Main Component Errors.

Main component	Problem	Cause	Solution
Compressor	Not operating	Motor insulation damaged.	Check resistance between terminals and unit frames.
		Strainer is clogged.	Clean / change the strainer.
		Oil is leaking.	Check oil levels.
	Stopped during operation..	Motor insulation failed.	After disconnecting the compressor wiring, check resistance between terminals and unit frames.
	Abnormal noise during operation.	Bad or improper R(L1) - S(L2) - T(L3) connections.	Check compressor R(L1) - S(L2) - T(L3) connections.
Outdoor Unit Fan	High pressure error when unit operates in cooling mode.	Motor failure, bad ventilation around outdoor unit heat exchanger.	Check the outdoor unit fan operation after the outdoor units have been turned off for a while. If any obstacles are around the outdoor unit heat exchanger, switch the outdoor unit OFF and remove.
Outdoor Unit EEV	Heating failure, frequent defrost.	Bad connector contact.	Check connector.
	No operation sound after switching on the power.	Coil failure.	Check resistance between terminals.
		Low refrigerant pressure.	Check refrigerant levels. Add refrigerant as necessary.
	Heating operation failed; outdoor unit heat exchanger is frozen.	EEV clogged.	Service necessary.
Low pressure error or discharge temperature error.			

### Note:

- When a system error occurs, the error code is displayed on the indoor unit or the wired control.
- If CH05/53/11 error occurs, check if auto-addressing is complete and the communication cables are properly installed.

### Self Diagnostics Check

All switches on outdoor unit PCB DIP Switch bank SW01 are factory set to OFF. To prepare for the self diagnostics check:

1. Verify that all indoor unit models are Gen 4. (See “DIP Switch Settings for Use With GEN 4 Indoor Units” earlier in this section.)
2. Flip No. 3 on DIP Switch bank SW01 to ON.
3. Push the reset SW01D button.

### Run Self Diagnostics Check

1. Power all indoor units.
2. Power all heat recovery units in conjunction with powering indoor units (heat recovery systems only).
3. Verify the outdoor units to indoor units / heat recovery units communications cable is installed and terminated correctly.
4. Verify the communications cable between outdoor unit frames is installed and terminated correctly. Inspect terminals (SODU [B] and SODU [A]) at each outdoor unit.
5. Verify that DIP Switches 6 and / or 7 on the slave outdoor unit(s) were properly adjusted for the job site configuration. See the “Outdoor Unit DIP Switch Settings” page in the “PCB Settings” section.
6. Power all outdoor units. Order does not matter on multi-frame installation.
7. As the power is provided to the main printed circuit board (PCB) on the Master outdoor unit, observe the SSD.
  - Wait. The perimeter segments will flash in sequence for forty-five (45) seconds.
  - Verify the microprocessor’s outdoor unit configuration agrees with the submittal information approved the design engineer (see Tables below).
  - Confirm that this step has been completed. The date is provided in sequence, and segment of the sequence will remain lit for two (2) seconds.

Figure 51: Location of SW01 and SW01D.

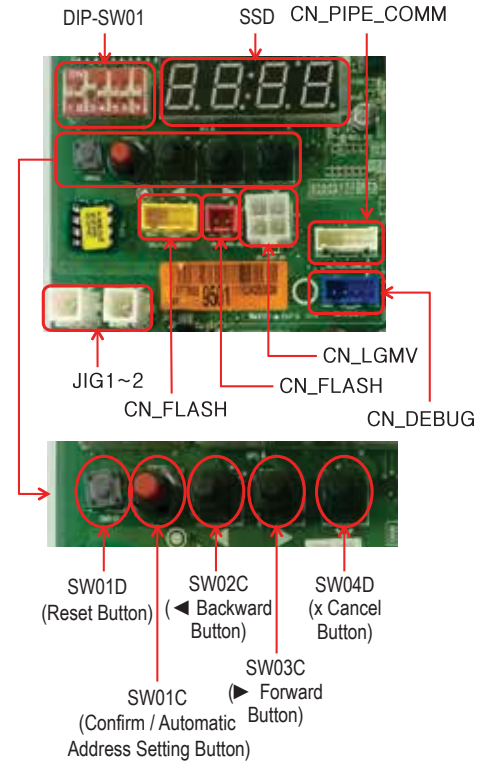

Figure 52: DIP Switch Bank SW01 Settings.

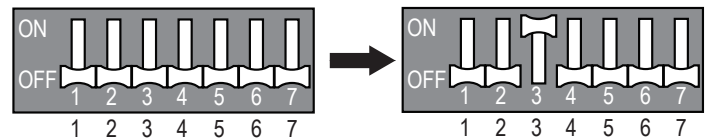

Table 60: Display Code Definitions—Outdoor Unit Nominal Capacity.

Display Code	8	10	12	14	18	20	22	24	26	28	32	34	36	38	40	42
Nominal Mb/h	6	8	10	12	14	16	18	20	22	24	26	28	30	32	34	36

Table 61: Display Code Definitions—Voltage.

Outdoor Unit Code	22	46
Electrical Requirements	208-230V / 60Hz / 3Ø	460V / 60Hz / 3Ø

Table 62: Segment Display Sequence (Two [2] seconds per segment following a forty-five [45] second wait).

Sequence	Description	Code(s)	
1	Master Outdoor Unit Nominal Capacity	8 - 14*	
2	Slave1 Outdoor Unit Nominal Capacity	8 - 24*	
3	Slave2 Outdoor Unit Nominal Capacity	8 - ~*	
4	Total Nominal Capacity of System	8 - ~ *	
5	Unit Type	Heat Pump	2
		Heat Recovery	3
6	Unit Voltage	208-230V / 60Hz / 3Ø	22
		460V / 60Hz / 3Ø	46
7	Efficiency Level	1 or 2	

\*See Tables above for code definitions.

### Note:

For Master versus Slave 1 or Slave 2 and Heat Pump versus Heat Recovery DIP switch settings, See the “Outdoor Unit DIP Switch Settings” page in the “PCB Settings” section.



## Checking the Compressor

If a compressor error, or any error related to the electrical system has occurred, check for the items below and follow the procedure listed.

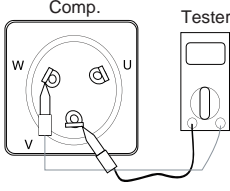
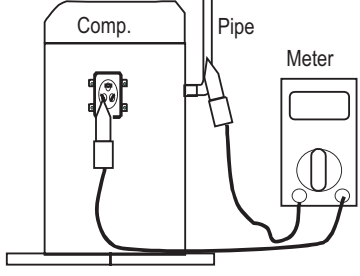
Step Number	Check for	Problem	Solution																																																												
1	How long has power been on during operation?	1. Power has been on for $\geq 12$ hours.	Go to Step 2.																																																												
		2. Power has been on for $\leq 12$ hours.	Go to Step 2 after power has been on for 12 hours.																																																												
2	<p>Does error occur again after starting operation?</p> <p>Test 1 Ohm meter testing terminal to terminal on the compressor.</p>  <p>Test 2 Ohm meter testing terminal to pipe ground. This reading must be <math>\geq 50M\Omega</math>.</p> 	<p>1. The compressor stops and same error appears again.</p> <p>2. Inverter output voltage is stable (1).</p>	<p>Check if IPM has failed.</p> <ul style="list-style-type: none"> <li>• Check insulation and coil resistors. If both are normal, restart the unit. If the same error occurs again, replace the compressor.</li> <li>• Insulation resistor: <math>\geq 50M\Omega</math> measured.</li> <li>• Coil resistors for 208-230V and 460V Heat Pump and Heat Recovery Units.</li> </ul> <table border="1"> <thead> <tr> <th colspan="3">JQC068MA</th> </tr> <tr> <th>Temp.</th> <th>77°F</th> <th>167°F</th> </tr> </thead> <tbody> <tr> <td>U-V</td> <td><math>0.216 \pm 7\% \Omega</math></td> <td><math>0.258 \pm 7\% \Omega</math></td> </tr> <tr> <td>V-W</td> <td><math>0.216 \pm 7\% \Omega</math></td> <td><math>0.258 \pm 7\% \Omega</math></td> </tr> <tr> <td>W-U</td> <td><math>0.216 \pm 7\% \Omega</math></td> <td><math>0.258 \pm 7\% \Omega</math></td> </tr> </tbody> </table> <table border="1"> <thead> <tr> <th colspan="3">JQC048MA</th> </tr> <tr> <th>Temp.</th> <th>77°F</th> <th>167°F</th> </tr> </thead> <tbody> <tr> <td>U-V</td> <td><math>0.302 \pm 7\% \Omega</math></td> <td><math>0.360 \pm 7\% \Omega</math></td> </tr> <tr> <td>V-W</td> <td><math>0.302 \pm 7\% \Omega</math></td> <td><math>0.360 \pm 7\% \Omega</math></td> </tr> <tr> <td>W-U</td> <td><math>0.302 \pm 7\% \Omega</math></td> <td><math>0.360 \pm 7\% \Omega</math></td> </tr> </tbody> </table> <table border="1"> <thead> <tr> <th colspan="3">JQC068MB / JQC068MBA</th> </tr> <tr> <th>Temp.</th> <th>77°F</th> <th>167°F</th> </tr> </thead> <tbody> <tr> <td>U-V</td> <td><math>0.113 \pm 7\% \Omega</math></td> <td><math>0.135 \pm 7\% \Omega</math></td> </tr> <tr> <td>V-W</td> <td><math>0.113 \pm 7\% \Omega</math></td> <td><math>0.135 \pm 7\% \Omega</math></td> </tr> <tr> <td>W-U</td> <td><math>0.113 \pm 7\% \Omega</math></td> <td><math>0.135 \pm 7\% \Omega</math></td> </tr> </tbody> </table> <table border="1"> <thead> <tr> <th colspan="3">JQC048MB / JQC048MBA</th> </tr> <tr> <th>Temp.</th> <th>77°F</th> <th>167°F</th> </tr> </thead> <tbody> <tr> <td>U-V</td> <td><math>0.113 \pm 7\% \Omega</math></td> <td><math>0.135 \pm 7\% \Omega</math></td> </tr> <tr> <td>V-W</td> <td><math>0.113 \pm 7\% \Omega</math></td> <td><math>0.135 \pm 7\% \Omega</math></td> </tr> <tr> <td>W-U</td> <td><math>0.113 \pm 7\% \Omega</math></td> <td><math>0.135 \pm 7\% \Omega</math></td> </tr> </tbody> </table>	JQC068MA			Temp.	77°F	167°F	U-V	$0.216 \pm 7\% \Omega$	$0.258 \pm 7\% \Omega$	V-W	$0.216 \pm 7\% \Omega$	$0.258 \pm 7\% \Omega$	W-U	$0.216 \pm 7\% \Omega$	$0.258 \pm 7\% \Omega$	JQC048MA			Temp.	77°F	167°F	U-V	$0.302 \pm 7\% \Omega$	$0.360 \pm 7\% \Omega$	V-W	$0.302 \pm 7\% \Omega$	$0.360 \pm 7\% \Omega$	W-U	$0.302 \pm 7\% \Omega$	$0.360 \pm 7\% \Omega$	JQC068MB / JQC068MBA			Temp.	77°F	167°F	U-V	$0.113 \pm 7\% \Omega$	$0.135 \pm 7\% \Omega$	V-W	$0.113 \pm 7\% \Omega$	$0.135 \pm 7\% \Omega$	W-U	$0.113 \pm 7\% \Omega$	$0.135 \pm 7\% \Omega$	JQC048MB / JQC048MBA			Temp.	77°F	167°F	U-V	$0.113 \pm 7\% \Omega$	$0.135 \pm 7\% \Omega$	V-W	$0.113 \pm 7\% \Omega$	$0.135 \pm 7\% \Omega$	W-U	$0.113 \pm 7\% \Omega$	$0.135 \pm 7\% \Omega$
		JQC068MA																																																													
Temp.	77°F	167°F																																																													
U-V	$0.216 \pm 7\% \Omega$	$0.258 \pm 7\% \Omega$																																																													
V-W	$0.216 \pm 7\% \Omega$	$0.258 \pm 7\% \Omega$																																																													
W-U	$0.216 \pm 7\% \Omega$	$0.258 \pm 7\% \Omega$																																																													
JQC048MA																																																															
Temp.	77°F	167°F																																																													
U-V	$0.302 \pm 7\% \Omega$	$0.360 \pm 7\% \Omega$																																																													
V-W	$0.302 \pm 7\% \Omega$	$0.360 \pm 7\% \Omega$																																																													
W-U	$0.302 \pm 7\% \Omega$	$0.360 \pm 7\% \Omega$																																																													
JQC068MB / JQC068MBA																																																															
Temp.	77°F	167°F																																																													
U-V	$0.113 \pm 7\% \Omega$	$0.135 \pm 7\% \Omega$																																																													
V-W	$0.113 \pm 7\% \Omega$	$0.135 \pm 7\% \Omega$																																																													
W-U	$0.113 \pm 7\% \Omega$	$0.135 \pm 7\% \Omega$																																																													
JQC048MB / JQC048MBA																																																															
Temp.	77°F	167°F																																																													
U-V	$0.113 \pm 7\% \Omega$	$0.135 \pm 7\% \Omega$																																																													
V-W	$0.113 \pm 7\% \Omega$	$0.135 \pm 7\% \Omega$																																																													
W-U	$0.113 \pm 7\% \Omega$	$0.135 \pm 7\% \Omega$																																																													
		3. Inverter output voltage is unstable or 0V (if digital tester is unavailable).	<p>Check the IPM. If normal, replace the inverter board.</p> <p>Check coil and insulation resistors.</p>																																																												

**\*When measuring voltage and current of inverter power circuit, values will appear differently depending on tools and circuits, because voltage, power supply current, or inverter output has no sine waveform. Also, output voltage changes when inverter output voltage has a pulse wave pattern.**

1. If using a movable tester to check if inverter output voltage is constant (when comparing relative voltage between lines), always use an analog meter. Exercise particular caution if the inverter output frequency is low, when using a tester, where the change of measured voltage values is large between other lines, when virtually the same values appear, or in situations where it can be difficult to determine if an inverter failed
2. Use a rectifier voltmeter (  $\rightarrow|$  ) if using a commercial frequency tester to measure inverter output values (when measuring absolute values). Accurate measuring values cannot be obtained with a general movable tester (for analog and digital mode).

### Checking the Outdoor Unit Fan

If there is a fan error, check the items below and follow the corresponding procedure listed.

Check	Problem	Solution																				
1. Fan motor is not operating. (Does fan motor fail again when operation starts?)  2. Fan motor vibration is excessive.	Power supply is not correct.	Check wire connections at the breaker. Modify the power supply voltage if it is beyond permissible specifications.																				
	Wiring is wrong.	<ul style="list-style-type: none"> <li>• Check wiring connections.</li> <li>• Check connector contacts.</li> <li>• Check that all components are firmly secured (tighten screws).</li> <li>• Check polarity connection.</li> <li>• Check ground wiring and for short circuits.</li> </ul>																				
	Motor has failed.	Measure the winding resistance of the motor coils. <table border="1" style="width: 100%; border-collapse: collapse;"> <thead> <tr> <th></th> <th colspan="2">Small Frame</th> <th colspan="2">Large Frame</th> </tr> </thead> <tbody> <tr> <td>Power Supply</td> <td>208V/230V, 60Hz, 3-phase</td> <td>460V, 60Hz, 3-phase</td> <td>208V/230V, 60Hz, 3-phase</td> <td>460V, 60Hz, 3-phase</td> </tr> <tr> <td>Rating Output</td> <td>1,500 W</td> <td>1,200 W</td> <td>900 W</td> <td>900 W</td> </tr> <tr> <td>Motor Resistance at 167°F</td> <td>5.0±7%Ω</td> <td>15.0±7%Ω</td> <td>6.55±5%Ω</td> <td>13.0±7%Ω</td> </tr> </tbody> </table>		Small Frame		Large Frame		Power Supply	208V/230V, 60Hz, 3-phase	460V, 60Hz, 3-phase	208V/230V, 60Hz, 3-phase	460V, 60Hz, 3-phase	Rating Output	1,500 W	1,200 W	900 W	900 W	Motor Resistance at 167°F	5.0±7%Ω	15.0±7%Ω	6.55±5%Ω	13.0±7%Ω
		Small Frame		Large Frame																		
	Power Supply	208V/230V, 60Hz, 3-phase	460V, 60Hz, 3-phase	208V/230V, 60Hz, 3-phase	460V, 60Hz, 3-phase																	
Rating Output	1,500 W	1,200 W	900 W	900 W																		
Motor Resistance at 167°F	5.0±7%Ω	15.0±7%Ω	6.55±5%Ω	13.0±7%Ω																		
Fuse is defective.	Replace the fuse.																					
Circuit board is defective.	Replace the circuit board following the steps below if errors occur again after resetting the power, and if there are no errors similar to those specified above. (Carefully check both connector and ground wires when replacing the circuit board.) <ul style="list-style-type: none"> <li>• Replace only the fan control board. If operation begins, then the fan control board was defective.</li> <li>• Check and replace inverter board and / or main board if fan operation continues to fail.</li> <li>• If problems continue to occur even after following the procedures above, then both boards are defective.</li> </ul>																					

# CHECKING THE ELECTRONIC EXPANSION VALVES

## Checking the Electronic Expansion Valves

Table 63: Pulse Signal Output Value and Valve Operation.

Output (ø) No.	Wire Color	Output State			
		1	2	3	4
ø1	White	ON	ON	OFF	ON
ø2	Yellow	ON	ON	ON	OFF
ø3	Orange	OFF	OFF	ON	OFF
ø4	Blue	OFF	OFF	OFF	ON

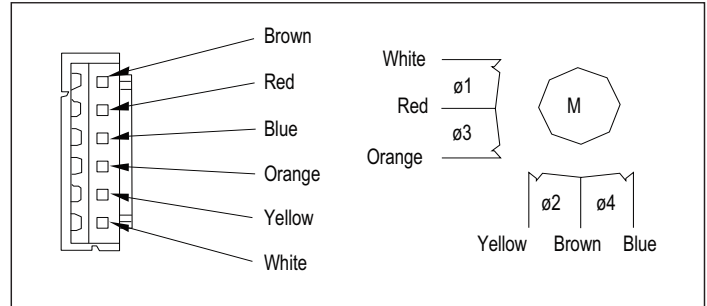

### Output Pulse Sequence

- Valve close sequence: 4 → 3 → 2 → 1 → 4.
- Valve open sequence: 1 → 2 → 3 → 4 → 1.

1. If the EEV open position does not change, output phase will be off.
2. If the output phase is different or continuously on, the motor will start vibrating.

### EEV Valve Operation

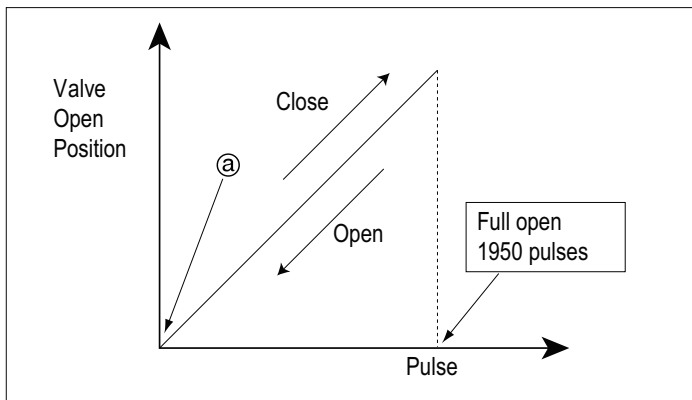

- At power on, open position signal is 2,000 pulses output, and valve position is set to "a" (see left). When the valve operates properly, noise and vibration will not occur. If the valve is closed, noise will be heard.
- Noise from EEV can be confirmed by touching the EEV surface with a screw driver and listening.
- If liquid refrigerant is present in EEV, noise will be lower.

## Checking the Electronic Expansion Valves, continued.

Figure 53: EEV Coil and Casing (Outdoor Unit).

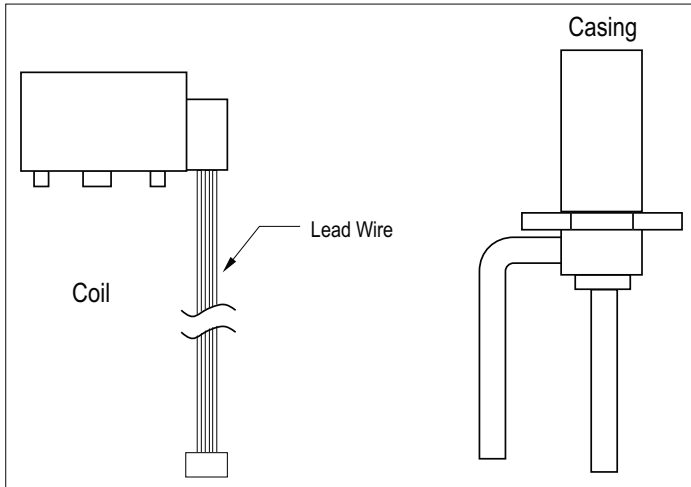
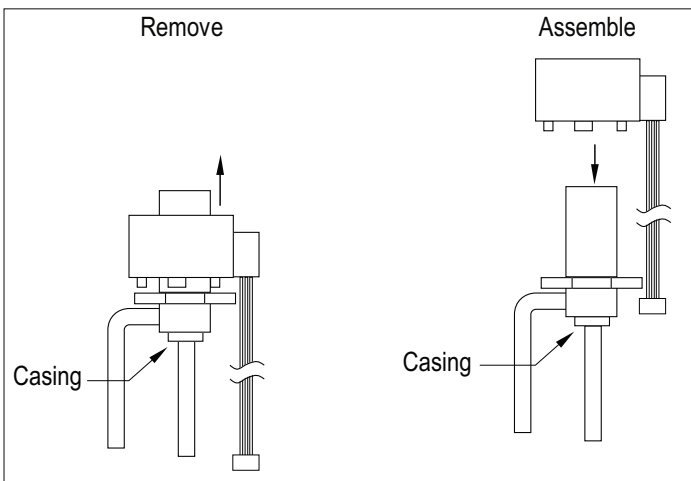

Figure 54: Removing and Assembling the Coil.



- Power off.
- Tightly grip the casing, and pull the coil up.
- During assembly, or when the coil is removed, take care not to bend the casing pipe.

# CHECKING THE ELECTRONIC EXPANSION VALVES

## Checking the Electronic Expansion Valves, continued.

Component	Problem	Diagnosis	Solution
Indoor Unit / Outdoor Unit	EEV locks up.	Check for a locked EEV, if the system is in a no-load state, if the driving motor is rotating, and a clicking sound can be heard.	Replace EEV.
	Incomplete EEV connection or assembly.	<ol style="list-style-type: none"> <li>1. Check if the pin is fully inserted into the connector.</li> <li>2. Check the color of the wiring; verify that the correct wire is connected.</li> <li>3. Remove the connector from the control board, and test the connection.</li> </ol>	Find the incomplete connection or assembly, and service accordingly.
Indoor Unit	EEV is closed, but valve is leaking.	<ol style="list-style-type: none"> <li>1. Operate one indoor unit in fan mode, and then operate another indoor unit in cooling mode.</li> <li>2. Check the liquid piping temperature of the indoor unit in fan mode (through the outdoor unit control board).</li> <li>3. Check if the fan is rotating and the EEV is closed. If there is a leak, the liquid piping temperature at the indoor unit in fan mode will be low.</li> </ol> <p>If the measured temperature is very low when compared to the suction temperature (that is displayed at the remote controller), then the EEV is not fully closed.</p>	If the amount that is leaking is excessive, replace the EEV.
			Check the resistance between the coil terminals (red-white, red-orange, brown-yellow, brown-blue).
Outdoor Unit	EEV motor coil has shorted out or has disconnected.	<ol style="list-style-type: none"> <li>1. Check the resistance between the coil terminals at the subcooling EEV (red-white, red-yellow, red-orange, red-blue).</li> <li>2. If the measured resistance value is in <math>52\Omega \pm 3\%</math> at <math>68^\circ\text{F}</math>, then the EEV is normal.</li> </ol>	Replace EEV coil.
		<ol style="list-style-type: none"> <li>1. Check the resistance between the coil terminals at the main / IV EEV (red-white, red-orange, brown-yellow, brown-blue).</li> <li>2. If the measured resistance value is <math>150\Omega \pm 10\%</math>, then the EEV is normal.</li> </ol>	Replace EEV.

## Checking the Inverter Compressor Phase Diode Bridge

1. Shut off main power. After main power is shut off, wait at least ten (10) minutes until inverter compressor PCB DC voltage is discharged.

Figure 55: Simplified Diagram of a Phase Diode Bridge.

### ⚠ WARNING

After switching off the main power supply and verifying that the DC voltage was discharged, wait for at least ten (10) minutes before checking the electrical components in the control box. There is risk of electric shock, physical injury or death.

2. Disconnect all connections to the three-phase diode bridge.
3. Set the multi-tester to diode mode.
4. Measured value must be 0.4V ~ 0.7V as shown in table below.
5. If the measured value is different than what is listed in the table below, set the multi-tester to resistance mode and measure again. If the value is too low (0Ω) or too high (hundreds MΩ), the inverter PCB needs to be replaced.
6. If the diode bridge is damaged, check if the inverter PCB assembly (IPM) also needs to be replaced.

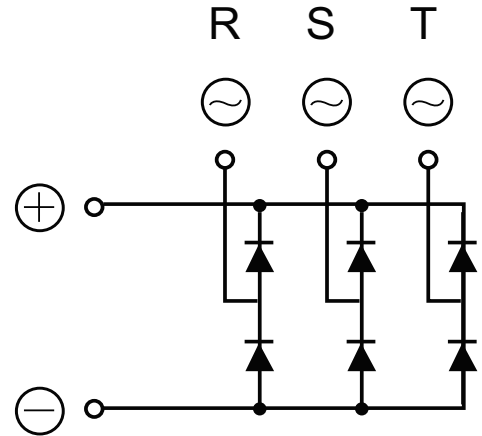

Figure 56: Location of Phase Diode Bridge Terminals (Appearances Will Vary Depending on Model).

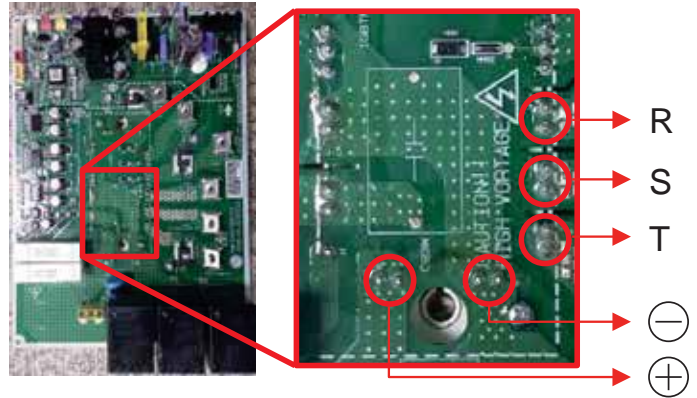

Table 64: Checking the Phase Diode Bridge.

Tester Terminal \ Diode Terminal	+ Terminal: black (-)	- Terminal: red (+)
R (~) : Red (+)	0.4V ~ 0.7V	-
S (~) : Red (+)	0.4V ~ 0.7V	-
T (~) : Red (+)	0.4V ~ 0.7V	-
R (~) : Black (-)	-	0.4V ~ 0.7V
S (~) : Black (-)	-	0.4V ~ 0.7V
T (~) : Black (-)	-	0.4V ~ 0.7V

Red (+) and Black (-) are the multi-tester terminals.

## Checking the Inverter Insulated-Gate Bipolar Transistor (IGBT) / Intelligent Power Module (IPM)

1. Shut off main power. After main power is shut off, wait at least ten (10) minutes until inverter compressor PCB DC voltage is discharged.

### ⚠ WARNING

After switching off the main power supply and verifying that the DC voltage was discharged, wait for at least ten (10) minutes before checking the electrical components in the control box. There is risk of electric shock, physical injury or death.

2. Disconnect all IGBT / IPM connections.
3. Set the multi-tester to diode mode.
4. Measured value must be 0.2 ~ 0.6 V as shown in the table below.
5. If the measured value is different than what is listed in the table below, then set the multi-tester to resistance mode and measure again. If the value is too low (0Ω) or too high (hundreds MΩ), the inverter PCB is damaged and needs to be replaced.

Figure 57: Simplified Diagram of an Inverter IGBT / IPM.

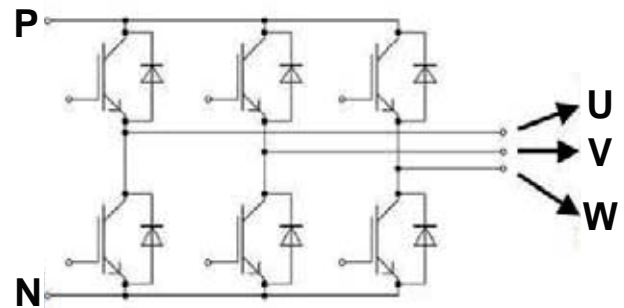

Figure 58: Location of IGBT / IPM Terminals (Appearances Will Vary Depending on Model).

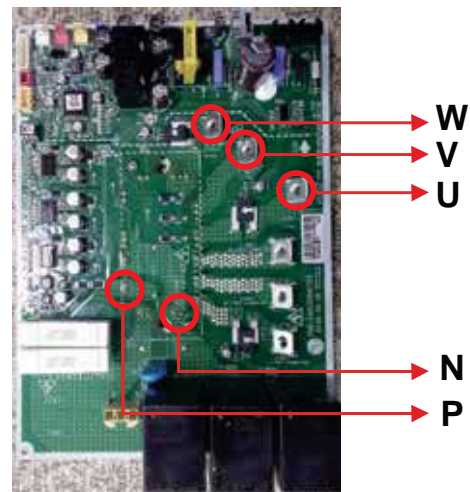

Table 65: Checking the Inverter IGBT / IPM.

	P Terminal: Black (-)	N Terminal: Red (-)
U Terminal : Red (+)	0.2 ~ 0.6 V	-
V Terminal : Red (+)	0.2 ~ 0.6 V	-
W Terminal : Red (+)	0.2 ~ 0.6 V	-
	P Terminal: Red (+)	N Terminal: Red (+)
U Terminal : Black (-)	-	0.2 ~ 0.6 V
V Terminal : Black (-)	-	0.2 ~ 0.6 V
W Terminal : Black (-)	-	0.2 ~ 0.6 V

Red (+) and Black (-) are the multi-tester terminals.

### Checking the Fan Intelligent Power Module (IPM)

1. Shut off main power. After main power is shut off, wait at least ten (10) minutes until the fan PCB DC voltage is discharged.

**⚠ WARNING**

After switching off the main power supply and verifying that the DC voltage was discharged, wait for at least ten (10) minutes before checking the electrical components in the control box. There is risk of electric shock, physical injury or death.

2. Disconnect the DC and the U, V, W fan connectors.
3. Set the multi-tester to diode resistance mode.
4. Measured value must be the same as shown below.
5. If the measured value between the P and N terminals of the IPM is low ( $0\Omega$ ), the fan PCB needs to be replaced because the IPM is damaged.
6. If the measured value is different than what is listed in the tables, the fan PCB needs to be replaced.

Figure 59: Location of Fan PCB Connections (Appearances Will Vary Depending on Model).

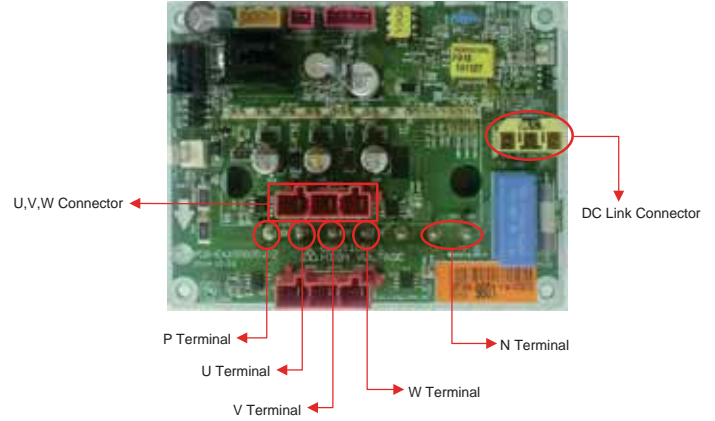

Table 66: Checking the Fan IPM.

	<b>P Terminal: Black (-)</b>	<b>N Terminal: Red (-)</b>
U Terminal : Red (+)	4.98 MΩ ± 10% (77°F)	5.85 MΩ ± 10% (77°F)
V Terminal : Red (+)	4.98 MΩ ± 10% (77°F)	5.85 MΩ ± 10% (77°F)
W Terminal : Red (+)	4.98 MΩ ± 10% (77°F)	5.85 MΩ ± 10% (77°F)
	<b>P Terminal: Red (+)</b>	<b>N Terminal: Red (+)</b>
U Terminal : Black (-)	4.49 MΩ ± 10% (77°F)	0.72 MΩ ± 10% (77°F)
V Terminal : Black (-)	4.49 MΩ ± 10% (77°F)	0.72 MΩ ± 10% (77°F)
W Terminal : Black (-)	4.49 MΩ ± 10% (77°F)	0.72 MΩ ± 10% (77°F)

Red (+) and Black (-) are the multi-tester terminals.

# CHECKING THE HIGH / LOW PRESSURE *MULTI V 5* SENSORS AND OUTDOOR FAN

## Checking the High / Low Pressure Sensors

Connect the manifold gauge to the outdoor unit service valve, and compare the high pressure sensor output to the low pressure sensor output to check for errors.

Figure 60: Pressure Sensor Output Characteristics.

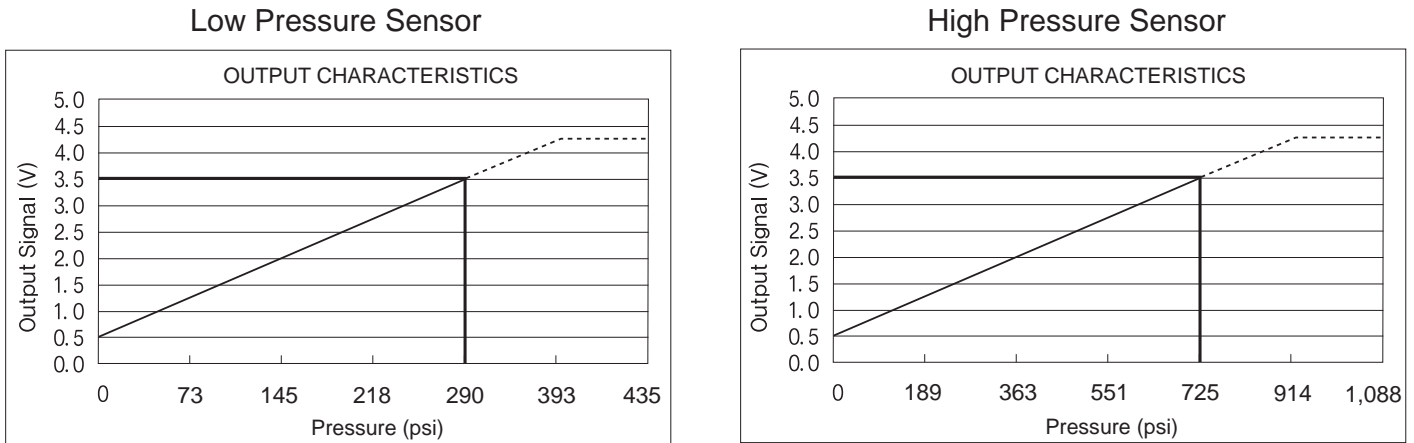

1. If the manifold gauge pressure reads 14.22 psi, it indicates the pressure dropped due to a refrigerant leak. Find the leak and repair it.
2. If the difference between the high and low pressure outputs is around 14.22 psi, the pressure sensor is normal.
3. If the difference between the high and low pressure outputs is >14.22 psi, the pressure sensor is damaged and needs to be replaced.

Figure 61: Pressure Sensor Schematic.

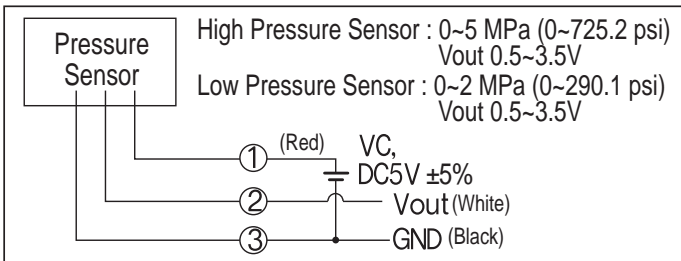

See the pressure sensor schematic at left. DC 5V will be measured between red and black wires. DC voltage measured between white and Black wire corresponds to charts above.

## Checking the Outdoor Fan

1. The inverter motor controls the number of rotations on the outdoor unit fan.
2. The high / low pressure sensors control the outdoor unit fan after compressor operation.
3. Even if the compressor is on, the outdoor unit fan may not operate due to low capacity, or if the outdoor temperature is low. This is normal, and the outdoor unit fan will begin to operate when the system reaches setpoint.

---

---

## Checking the Valves

Compare valve operation to the output signal of the control board.

### Oil Return Solenoid Valve

1. The oil return solenoid valve is located at the bottom of the accumulator. The oil return solenoid valve will start operating after the compressor has been operating for a certain period. This operation transfers oil stored at the bottom of the accumulator into the compressor.
2. After the compressor starts operating, the oil return solenoid valve will be on for two (2) minutes. Check for operation noise and piping vibration on the oil return solenoid valve.
3. The oil return solenoid valve will also turn on after the compressor stops operating.
4. The oil return solenoid valve will turn on and off repeatedly due to cycle operation. This is normal and does not indicate that the outdoor unit is malfunctioning.
5. Insulation resistance between the oil return solenoid valve connection and the coil must be >100 MΩ (measure with a DC mega-tester [DC 500V]).

### Partial Defrost Solenoid Valve

1. Defrost operation helps eliminate ice that has accumulated on the heat exchanger, recovering its performance.
2. When the system is in partial defrost operation, two (2) solenoid valves will turn on and off in sequence for six (6) minutes.
3. The partial solenoid valves will turn off after partial defrost operation has ended.
  - Partial solenoid valve operation change can be checked by comparing the before and after temperatures of the bypass piping.
4. Insulation resistance between the partial defrost solenoid valve connection and the coil must be >100 MΩ (measure with a DC mega-tester [DC 500V]).

### Supercooled Bypass Valve

1. When the compressor starts to operate, it opens the supercooled bypass valve for about one (1) minute (the supercooled bypass valve is on).
2. To reduce the high/low-pressure difference. The supercooled bypass will open (turn on) five (5) seconds after the compressor stops to reduce the high / low pressure difference in the system.
3. If the compressor suction pipe temperature drops below a certain temperature, the supercooled bypass valve opens (turns on).
4. The supercooled bypass valve will open or close based on suction piping temperature. This is normal and does not indicate the outdoor unit is malfunctioning.
5. Changes of solenoid valve operation can be verified by measuring bypass outlet piping temperature, detecting refrigerant sound, etc.
6. Insulation resistance between the supercooled bypass valve connection and the coil must be >100 MΩ (measure with a DC mega-tester [DC 500V]).

# CHECKING THE VALVES / TEMPERATURE SENSORS

## Checking the Four-Way Reverse Valve

1. The four-way reverse valve must be OFF before the outdoor and indoor units are powered up and turned on.
2. The four-way reverse valve must be OFF during cooling, defrost, and oil recovery operation. The four-way reverse valve must be ON during heating operation.
3. When switching from cooling to heating operation, the four-way valve position changes during the three minute mode change restart.
4. To check if the four-way reverse valve is operating in cooling or heating mode, touch the piping surface of the low pressure service valve.

Figure 62: Refrigerant Flowchart of the Four-Way Reverse Valve.

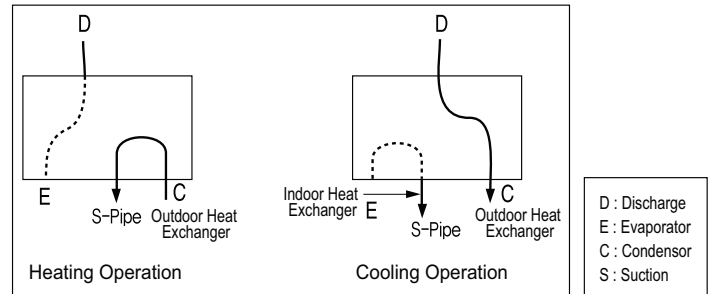

5. See diagram at right for the refrigerant flowchart of the four-way reverse valve.
6. Insulation resistance between the four-way reverse valve connection and the coil must be >100 MΩ (measure with a DC mega-tester [DC 500V]).

## Checking the Temperature Sensors

- Outdoor Temperature Sensor: TH1
  - Pipe Temperature Sensor: TH2
  - Discharge Pipe (D-pipe) Temperature Sensor: TH3
1. Check the temperature sensor installation and connections.
  2. Check if the connection contact of the temperature sensor is normal.
  3. Measure the resistance of temperature sensor.

Table 67: Temperature Sensor Resistance Values.

Temperature Sensor	TH1	TH2	TH3
Resistance	10 KΩ ± 5% @ 77°F	5 KΩ ± 5% @ 77°F	200 KΩ ± 5% @ 77°F
	1.07 KΩ ± 5% @ 185°F	0.532 KΩ ± 5% @ 185°F	27.67 KΩ ± 5% @ 185°F

**⚠ WARNING** Please refer to the Safety Precautions on pages 4-7 for more detail to prevent injury or death regarding the operation and service troubleshooting of the Multi V product.

---

---

## General Information

LG VRF system's core logic uses error codes to indicate that an abnormal operation occurred. Error codes help guide a trained service technician to identify why and what caused the error to display, and help track the frequency of malfunction occurrences.

There are four (4) levels of error code responses; the system responds accordingly, depending on the severity of the malfunction assigned to the malfunction. The level of responses range from "notify and keep operating" (Level 4), to "immediate system shutdown" (Level 1).

All error codes can be viewed at the outdoor unit seven segment display (SSD) and with LGMV software. If an error codes shows on one (1) or more indoor unit zone controllers, it will display on LGMV, central controllers, BMS, or any other LG device connected to Comm bus - Internet A/B. Indoor unit error code notifications will display differently based on location of the problem.

### Level 4 Responses

Level 4 responses display the error code, but the system continues to operate (operate indefinitely). When the malfunction is fixed, the error code remains until the master outdoor unit's microprocessor is reset, and operation has resumed for 130 minutes without the malfunction reoccurring.

### Level 3 Responses

Level 3 responses display the error code on all zone controllers, central controllers, and on BMS systems. For Level 3 responses, the Multi V system will shut down for three (3) minutes, and then the master microprocessor in the outdoor unit will automatically restart the system.

If the malfunction reoccurs up to a total of nine (9) times within one (1) hour, the system will display the error code, shut down, and restart again each time. If the malfunction occurs a tenth (10th) time within the same one (1) hour, the system shuts down permanently, assigning the error to a Level 1 response that requires a manual restart. The error code displays on the zone controllers and central controllers until the malfunction is fixed.

### Level 2 Responses

Level 2 responses are communications related errors only. Level 2 responses activate after ten (10) attempts to communicate have occurred. After communications have been re-established, the error codes display for one (1) minute. If the communications are restored, then the error code disappears. If the communication is lost within one (1) minute, the error code remains.

Error codes for Level 2 responses stop appearing on the zone and central controllers as soon as communications are restored, without the need to reset power at the Master outdoor unit or to restart the entire system.

Multi V 5 error codes for Level 2 responses appear where the problem occurs, and time limits differ depending on type:

1. Communications lost between outdoor unit PCBs – no time delay.
2. Communications lost between the indoor unit and the outdoor unit for three (3) minutes.
3. Communications lost between the indoor unit and heat recovery unit for ten (10) seconds.
4. Communications lost between outdoor unit external PCBs for ten (10) seconds.

### Level 1 Responses

Many Level 1 responses call for an immediate system shutdown, and, in almost all abnormal operational situations, occur after the algorithm monitoring system verifies that the malfunction is real (to avoid nuisance alarms and false positives). Level 1 responses are displayed at zone controllers, central controllers, BMS, LGMV, and the outdoor unit SSD. They cannot be cleared until the problem that caused it is fixed.

Before a Level 1 response is assigned, the Multi V algorithm initially assigns a Level 3 response to any system malfunction that is not communications related. The system follows Level 3 protocol until the tenth (10th) time a malfunction occurs, at which time the system shuts down, the malfunction changes from Level 3 to Level 1, and a manual restart is required. The entire Level 3 auto restart to Level 1 shut down sequence will repeat until the malfunction is fixed.

## Note:

For more information on Multi V Levels and error codes, see the troubleshooting pages in this section, and contact an LG trained technician.

# ERROR CODE TABLES

**⚠ WARNING** Please refer to the Safety Precautions on pages 4-7 for more detail to prevent injury or death regarding the operation and service troubleshooting of the Multi V product.

## Error Code Display

The seven segment display on the main board displays error codes. Error codes are 3 or 4 digit numbers. The rightmost number designates the ODU frame (1=Master; 2=Slave1; 3=Slave2). The other two or three digits indicate the error.

Examples: 211 = Error No. 21 on master unit; 212 = Error No. 21 on slave 1 unit; 213 = Error No. 21 on slave2 unit, 1051 = Error No. 105 on master unit.

- c1 refers to inverter 1 and c2, inverter 2, etc.
- Heat recovery unit errors will be followed by the heat recovery unit number as displayed on LGMV, or adding one (1) to the rotary switch setting.
- If two or more errors occur simultaneously, the lower error code number is displayed first.
- After error is resolved, the error code disappears.

Figure 63: Example of an Error Code.

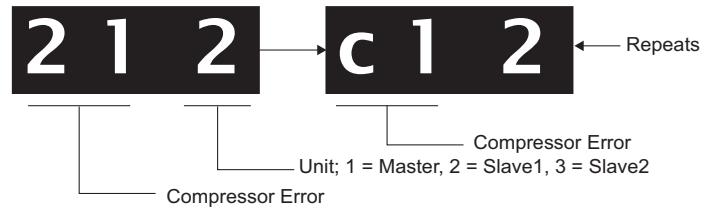

## Nomenclature Definitions

- MICOM: Non-volatile memory chip where unit setup information is stored.
- EEPROM: Non-volatile memory chip where device identification, size, and factory defined default component operating parameters are stored.

See the error code tables below and on the following pages. Pages after the tables include detailed information for the error codes used for Multi V systems.

Table 68: Error Codes.

Error Code	Description	Details	
Indoor Unit	0 1	Indoor unit return air or optional remote wall temperature sensor communications error.	Indoor unit air temperature sensor disconnected or shorted. (Check the wiring, connection on the indoor unit PCB, then check the thermistor.)
	0 2	Indoor unit inlet pipe temperature sensor communication error.	Indoor unit inlet pipe temperature sensor is disconnected or shorted. (Check the connection on the indoor unit PCB, then check the thermistor.)
	0 3	Communication error between zone controller and indoor unit.	Indoor unit PCB is not receiving communications signal from zone controller.
	0 4	Indoor unit drain overflow error.	Drain pump and/or float switch could be malfunctioning. Also check drain line for obstructions.
	0 5	Communication error between outdoor unit PCB and indoor unit PCB.	Indoor unit communications PCB is not receiving signal from outdoor unit communications PCB for more than 5 minutes. Check indoor unit PCB for issues.
	0 6	Indoor unit or hydro kit outlet pipe temperature sensor error.	<ul style="list-style-type: none"> <li>• Indoor unit outlet pipe temperature sensor is disconnected or shorted. (Check the connection on the indoor unit PCB, then check the thermistor.)</li> <li>• Hydro kit liquid side temperature sensor is disconnected or shorted. Values read less than -43°C or greater than +96°C (less than -45.4°F or greater than +204.8°F).</li> </ul>
	0 7	Indoor units are not operating in the same mode. (Heat pump applications only)	Different operation mode between indoor units.
	0 8	Hydro kit hot water storage tank temperature sensor error.	Pipe temperature sensor disconnected, shorted, or opened.
	0 9	Indoor unit EEPROM error.	<ul style="list-style-type: none"> <li>• Communication error between the indoor unit PCB board and its option card. (The option card is about 1' x 1' and is plugged into the indoor unit PCB board. Check connection between the two.)</li> <li>• Communication error between EEPROM on indoor unit main PCB.</li> <li>• Indoor unit EEPROM data is not available.</li> </ul>

**WARNING** Please refer to the Safety Precautions on pages 4-7 for more detail to prevent injury or death regarding the operation and service troubleshooting of the Multi V product.

Table 69: Error Codes, continued.

Error Code			Description	Details	
Indoor Unit	1	0	-	Indoor unit BLDC fan motor communications error.	<ul style="list-style-type: none"> <li>Fan motor has been removed or is defective. Refer to the resistance and voltage check charts in this service manual.</li> <li>The system has detected the fan motor is not spinning.</li> <li>On new installs, verify installation manual and paperwork were removed from fan discharge shroud during installation.</li> <li>Check the wiring plug and connections (if applicable).</li> </ul>
	1	1	-	Communication error between hydro kit and inverter compressor PCB.	Hydro kit is not receiving communications signal from inverter compressor PCB.
	1	2	-	Hydro kit inverter compressor PCB error.	Hydro kit inverter compressor PCB error.
	1	3	-	Hydro kit solar heat pipe temperature sensor error.	Solar heat pipe temperature sensor disconnected, shorted, or opened.
	1	4	-	Hydro kit flow switch error.	Flow switch failed to close.
	1	5	-	Hydro kit leaving water temperature has exceeded 185°F (85°C).	Temperature sensor is defective or there is hot water inflow.
	1	6	-	Hydro kit indoor unit water pipe temperature and ambient temperature sensor communication error.	Water inlet and outlet pipe temperature sensor disconnected, shorted, or opened.
	1	7	-	<ul style="list-style-type: none"> <li>Hydro kit inlet pipe temperature sensor communication error.</li> <li>Outside air duct inlet pipe temperature sensor communication error.</li> </ul>	<ul style="list-style-type: none"> <li>Water inlet temperature sensor disconnected or shorted. Values read less than -43°C or greater than +96°C (less than -45.4°F or greater than +204.8°F).</li> <li>Temperature sensor disconnected, shorted, or opened.</li> </ul>
	1	8	-	Hydro kit outlet pipe temperature sensor communication error.	Outlet pipe temperature sensor disconnected, shorted, or opened.
	2	3	0	Refrigerant leak sensor error. Only displayed at the indoor unit and its wired remote controller.	<ul style="list-style-type: none"> <li>Refrigerant leak sensor error; sensor is malfunctioning.</li> <li>Error will also be displayed if the function is enabled on the wired remote controller, and there is not a sensor installed.</li> <li>Refrigerant leak is detected when &gt;6,000 ppm.</li> <li>Enable the function through the function code on the remote controller.</li> </ul> <ol style="list-style-type: none"> <li>Operation stop.</li> <li>Solenoid valve closes on the indoor unit side.</li> <li>CH230 is displayed. If the communication baud is 1,200 bps, then only the zone controller can display the CH230; central controller cannot display the error due to lack of information.</li> <li>Buzzer rings 2 long buzzes every 1 second. Ringing stops when there is an input from the controller. (If there is a hard lock, then only the controller can make the hard lock to stop buzzing. If leak sensor measures under 1.5V, then it is considered normal and the buzzing stops.</li> <li>To release the error, power needs reset.</li> </ol>
2	3	7	Communication error between outdoor unit PCB and indoor unit PCB. Only displayed at the indoor unit and its wired remote controller.	Indoor unit communications PCB is not receiving signal from outdoor unit communications PCB for more than 3 minutes. Check RS-485 communications for issues.	
2	3	8	Communication error between outdoor unit PCB and indoor unit PCB. Displayed at the indoor unit and its wired remote controller.	Indoor unit communications PCB is not receiving signal from outdoor unit communications PCB for more than 3 minutes. Check outdoor unit PCB for issues.	

Error Codes

# ERROR CODE TABLES

**⚠ WARNING** Please refer to the Safety Precautions on pages 4-7 for more detail to prevent injury or death regarding the operation and service troubleshooting of the Multi V product.

Table 70: Error Codes, continued.

Error Code			Description	Details	
Outdoor Unit	2	1	1	Master outdoor unit inverter board IPM fault error; Inverter driver detects overcurrent; Error code is determined by overcurrent in any one phase of compressor.	<ul style="list-style-type: none"> <li>Detected by the CT sensor on the IGBT PC board.</li> <li>Overcurrent in compressor UVW phases.</li> <li>Damaged compressor.</li> </ul>
	2	1	2	Slave1 outdoor unit inverter board IPM fault error; Inverter driver detects overcurrent; Error code is determined by overcurrent in any one phase of compressor.	<ul style="list-style-type: none"> <li>Damaged IPM on inverter board.</li> <li>Compressor disconnected.</li> </ul>
	2	1	3	Slave2 outdoor unit inverter board IPM fault error; Inverter driver detects overcurrent; Error code is determined by overcurrent in any one phase of compressor.	<ul style="list-style-type: none"> <li>Damaged inverter board – input voltage too low. For 208-230V: On 068 compressors = 143A for a minimum of 3μs; on 048 compressors = 96A for a minimum of 3μs. For 460V: On 068 compressors = 80 A for a minimum of 3μs; On 048 compressors = 56A for a minimum of 3μs.</li> </ul>
	2	2	1	Master outdoor unit inverter PCB AC input overcurrent (RMS) error.	<ul style="list-style-type: none"> <li>Overcurrent of outdoor unit inverter board PCB.</li> </ul>
	2	2	2	Slave1 outdoor unit inverter PCB AC input overcurrent (RMS) error.	<ul style="list-style-type: none"> <li>Under voltage.</li> <li>Refrigerant flow restriction from defective EEV.</li> </ul>
	2	2	3	Slave2 outdoor unit inverter PCB AC input overcurrent (RMS) error.	<ul style="list-style-type: none"> <li>Refrigerant charge is too high (overcharged).</li> </ul>
	2	3	1	Low DC voltage sensed at the master outdoor unit inverter compressor DC link.	<ul style="list-style-type: none"> <li>System shut off because the DC link voltage fell below 50V (for both 208-230V and 460V units), or exceeded 550V (for 208-230V units) or 1,000V (for 460V units) for a minimum of 250μs.</li> </ul>
	2	3	2	Low DC voltage sensed at the slave1 outdoor unit inverter compressor DC link.	<ul style="list-style-type: none"> <li>Start diagnosis at the inverter socket on the outdoor unit noise filter PCB.</li> </ul>
	2	3	3	Low DC voltage sensed at the slave2 outdoor unit inverter compressor DC link.	<ul style="list-style-type: none"> <li>There is a capacitor that is not working properly, or the voltage at the capacitor is out of range.</li> <li>Disconnected DC link.</li> <li>Damaged electrical condenser component (serving capacitor) on inverter driver board.</li> </ul>
	2	4	1	System has been turned off by the master outdoor unit high pressure switch.	<ul style="list-style-type: none"> <li>Master outdoor unit high pressure switch error.</li> <li>Check the connection on the outdoor unit PCB.</li> <li>Use chart in Troubleshooting section of the manual to check signal output (V DC) versus actual pressure.</li> </ul>
	2	4	2	System has been turned off by the slave1 outdoor unit high pressure switch.	<ul style="list-style-type: none"> <li>Slave1 outdoor unit high pressure switch error.</li> <li>Check the connection on the outdoor unit PCB.</li> <li>Use chart in Troubleshooting section of the manual to check signal output (V DC) versus actual pressure.</li> </ul>
	2	4	3	System has been turned off by the slave2 outdoor unit high pressure switch.	<ul style="list-style-type: none"> <li>Slave2 outdoor unit high pressure switch error.</li> <li>Check the connection on the outdoor unit PCB.</li> <li>Use chart in Troubleshooting section of the manual to check signal output (V DC) versus actual pressure.</li> </ul>
	2	5	1	Input voltage to the master outdoor unit is too high or too low.	<ul style="list-style-type: none"> <li>Master outdoor unit has an input voltage of ≤140V or ≥300V (for 208-230V units), or an input voltage of ≤414V or ≥528V (for 460V units).</li> </ul>
	2	5	2	Input voltage to the slave1 outdoor unit is too high or too low.	<ul style="list-style-type: none"> <li>Slave1 outdoor unit has an input voltage of ≤140V or ≥300V (for 208-230V units), or an input voltage of ≤414V or ≥528V (for 460V units).</li> </ul>
	2	5	3	Input voltage to the slave2 outdoor unit is too high or too low.	<ul style="list-style-type: none"> <li>Slave2 outdoor unit has an input voltage of ≤140V or ≥300V (for 208-230V units), or an input voltage of ≤414V or ≥528V (for 460V units).</li> </ul>
	2	6	1	Master outdoor unit inverter compressor operation error.	Inverter compressor failed to start.
	2	6	2	Slave1 outdoor unit inverter compressor operation error.	
	2	6	3	Slave2 outdoor unit inverter compressor operation error.	
	2	9	1	Master outdoor unit inverter compressor overcurrent error.	<ul style="list-style-type: none"> <li>Outdoor unit inverter compressor current draw is too high.</li> </ul>
2	9	2	Slave1 outdoor unit inverter compressor overcurrent error.	<ul style="list-style-type: none"> <li>Compressor defect and restriction in refrigerant piping are possible causes.</li> </ul>	
2	9	3	Slave2 outdoor unit inverter compressor overcurrent error.		

**⚠ WARNING** Please refer to the Safety Precautions on pages 4-7 for more detail to prevent injury or death regarding the operation and service troubleshooting of the Multi V product.

Table 71: Error Codes, continued.

Error Code			Description	Details	
Outdoor Unit	3	2	1	Excessive increase in master outdoor unit inverter compressor1 gas discharge temperature.	<ul style="list-style-type: none"> <li>System shutdown happens when discharge pipe temperature rises &gt;115°C (239°F) for 10 seconds, or compressor dome temperature equals 105°C (221°F) for 10 seconds.</li> <li>Check the inverter compressor discharge pipe temperature sensor.</li> <li>Check for low refrigerant / leaks.</li> <li>Check for a defective EEV.</li> <li>Check for a defective liquid spray valve.</li> </ul>
	3	2	2	Excessive increase in slave1 outdoor unit inverter compressor1 gas discharge temperature.	
	3	2	3	Excessive increase in slave2 outdoor unit inverter compressor1 gas discharge temperature.	
	3	3	1	Excessive increase in master outdoor unit inverter compressor2 gas discharge temperature.	
	3	3	2	Excessive increase in slave1 outdoor unit inverter compressor2 gas discharge temperature.	
	3	3	3	Excessive increase in slave2 outdoor unit inverter compressor2 gas discharge temperature.	
	3	4	1	Master outdoor unit compressor high pressure safety tripped.	<ul style="list-style-type: none"> <li>Shutdown due to if one compressor's high pressure is &gt;4,000 kPa (580 psi) for ten (10) seconds.</li> <li>Check the high pressure sensor, indoor unit or outdoor unit fan(s), refrigerant, EEV, service valve (may be clogged); check for defective outdoor unit PCB, indoor unit pipe temperature sensor, or hot gas valve. Also, outdoor unit may not have enough clearance (cooling operation), or indoor unit filter may be clogged (heating operation).</li> </ul>
	3	4	2	Slave1 outdoor unit compressor high pressure safety tripped.	
	3	4	3	Slave2 outdoor unit compressor high pressure safety tripped.	
	3	5	1	Master outdoor unit low side pressure below allowable limits.	<ul style="list-style-type: none"> <li>System will shut down when an abnormal low pressure condition occurs.</li> <li>Shut down occurs when the sum of all compressors inverter frequency &lt;30Hz = low &lt;110 kPa for 1 minute.</li> <li>When operating in cooling mode: Low side pressure &lt;400 kPa for 1 minute; High side pressure is &lt;2,200 kPa. Check for refrigerant leaks (low refrigerant charge), or a defective indoor unit EEV.</li> <li>When operating in heating mode: Low side pressure &lt;230 kPa for 1 minute; High side pressure is &lt;1,800 kPa. Check for refrigerant leaks (low refrigerant charge), or a defective outdoor unit EEV.</li> </ul>
	3	5	2	Slave1 outdoor unit low side pressure below allowable limits.	
	3	5	3	Slave1 outdoor unit low side pressure below allowable limits.	
	3	6	1	Master outdoor unit inverter 1 or inverter 2 low compression ratio.	<ul style="list-style-type: none"> <li>Outdoor unit is experiencing a problem developing compressor lift. Error is calling out low compression ratio. System will shut down and display error code "CH36**".</li> <li>During ongoing operation, if the compression ratio is &lt;1.6 for 2 to 5 minutes following a change in position of the reversing valve (either direction). If compression ratio is &lt;1.6, delay 5 minutes for condition to correct itself before raising the error.</li> <li>During low ambient cooling operation following an initial compressor start, if compression ratio is &lt;1.1 for 2 minutes, if compression ratio is &lt;1.3 for 3 minutes.</li> </ul>
	3	6	2	Slave1 outdoor unit inverter 1 or inverter 2 low compression ratio.	
	3	6	3	Slave2 outdoor unit inverter 1 or inverter 2 low compression ratio.	
	4	0	1	Master outdoor unit inverter compressor current transducer (CT) sensor error.	Master outdoor unit inverter compressor current transducer (CT) detection sensor disconnected, shorted, or opened.
4	0	2	Slave1 outdoor unit inverter compressor current transducer (CT) sensor error.	Slave1 outdoor unit inverter compressor current transducer (CT) detection sensor disconnected, shorted, or opened.	
4	0	3	Slave2 outdoor unit inverter compressor current transducer (CT) sensor error.	Slave2 outdoor unit inverter compressor current transducer (CT) detection sensor disconnected, shorted, or opened.	
4	1	1	Master outdoor unit inverter compressor1 discharge pipe temperature sensor error.	<ul style="list-style-type: none"> <li>Error can also occur if the system is operating in cooling at extremely low temperatures with no low ambient kit.</li> <li>Compressor discharge pipe temperature sensor (TH3) is not installed or connected properly.</li> <li>Defective compressor discharge pipe sensor (TH3) (opened or shorted);</li> <li>Defective outdoor unit PCB.</li> </ul>	
4	1	2	Slave1 outdoor unit inverter compressor1 discharge pipe temperature sensor error.		
4	1	3	Slave2 outdoor unit inverter compressor1 discharge pipe temperature sensor error.		

# ERROR CODE TABLES

**⚠ WARNING** Please refer to the Safety Precautions on pages 4-7 for more detail to prevent injury or death regarding the operation and service troubleshooting of the Multi V product.

Table 72: Error Codes, continued.

Error Code			Description	Details	
Outdoor Unit	4	2	1	Master outdoor unit low pressure sensor error.	<ul style="list-style-type: none"> <li>• Check the connection on the outdoor unit PCB.</li> <li>• Thermistor shorted or opened.</li> </ul>
	4	2	2	Slave1 outdoor unit low pressure sensor error.	
	4	2	3	Slave2 outdoor unit low pressure sensor error.	
	4	3	1	Master outdoor unit high pressure sensor error.	
	4	3	2	Slave1 outdoor unit high pressure sensor error.	
	4	3	3	Slave2 outdoor unit high pressure sensor error.	
	4	4	1	Master outdoor unit ambient temperature sensor error.	
	4	4	2	Slave1 outdoor unit ambient temperature sensor error.	
	4	4	3	Slave2 outdoor unit ambient temperature sensor error.	
	4	5	1	Master outdoor unit heat exchanger pipe temperature sensor.	<ul style="list-style-type: none"> <li>• Check the connection on the outdoor unit PCB.</li> <li>• Thermistor shorted or opened.</li> </ul>
	4	5	2	Slave1 outdoor unit heat exchanger pipe temperature sensor.	
	4	5	3	Slave2 outdoor unit heat exchanger pipe temperature sensor.	
	4	6	1	Master outdoor unit suction pipe temperature sensor error.	<ul style="list-style-type: none"> <li>• Check the connection on the outdoor unit PCB.</li> <li>• Thermistor shorted or opened.</li> </ul>
	4	6	2	Slave1 outdoor unit suction pipe temperature sensor error.	
	4	6	3	Slave2 outdoor unit suction pipe temperature sensor error.	
	4	7	1	Master outdoor unit inverter compressor2 discharge temperature sensor error.	<ul style="list-style-type: none"> <li>• Error can also occur if the system is operating in cooling at extremely low temperatures with no low ambient kit.</li> <li>• Check the connection on the outdoor unit PCB.</li> <li>• Thermistor shorted or opened.</li> <li>• Defective outdoor unit PCB.</li> </ul>
	4	7	2	Slave1 outdoor unit inverter compressor2 discharge temperature sensor error.	
	4	7	3	Slave2 outdoor unit inverter compressor2 discharge temperature sensor error.	
	4	9	1	Master outdoor unit IPM temperature sensor error.	<ul style="list-style-type: none"> <li>• Check the connection on the outdoor unit PCB.</li> <li>• Thermistor shorted or opened.</li> </ul>
	4	9	2	Slave1 outdoor unit IPM temperature sensor error.	
4	9	3	Slave2 outdoor unit IPM temperature sensor error.		
5	0	1	Master outdoor unit loss of phase.	One or more of R(L1), S(L2), T(L3) input power line connections is / are missing for the master outdoor unit.	
5	0	2	Slave1 outdoor unit loss of phase.	One or more of R(L1), S(L2), T(L3) input power line connections is / are missing for the slave1 outdoor unit.	
5	0	3	Slave2 outdoor unit loss of phase.	One or more of R(L1), S(L2), T(L3) input power line connections is / are missing for the slave2 outdoor unit.	
5	1	1	Combination ratio is out of range.	The total of the nominal indoor unit capacity is less than 50% or more than 130% of the nominal outdoor unit capacity.	
5	1	2	Total indoor unit capacity exceeds allowable heat recovery unit branch capacity. (Heat Recovery Systems only.)	<p>Value of total indoor unit capacity exceeds allowable heat recovery unit branch capacity specifications. After auto-pipe detection is complete, wait 5 minutes, then verify connected capacity. System will display error if:</p> <ul style="list-style-type: none"> <li>• The heat recovery unit port addresses are all unique, then &gt;54 Mbh single indoor unit connected; &gt;54 Mbh total of multiple IDUs connected.</li> <li>• If 2 heat recovery unit port addresses are the same and the ports are twinned; &gt;108 Mbh total of multiple indoor units are connected.</li> <li>• If 3 heat recovery unit port addresses are the same and the ports are all connected, &gt;162 Mbh total of multiple indoor units connected.</li> <li>• If the total connected indoor unit nominal capacity exceeds 192 Mbh for a single heat recovery unit.</li> </ul>	

**⚠ WARNING** Please refer to the Safety Precautions on pages 4-7 for more detail to prevent injury or death regarding the operation and service troubleshooting of the Multi V product.

Table 73: Error Codes, continued.

Error Code			Description	Details	
Outdoor Unit	5	2	1	Communication error between master outdoor unit main PCB and inverter PCB.	<ul style="list-style-type: none"> <li>• Communication error between main PCB and inverter PCB.</li> <li>• Check connections at both sockets.</li> <li>• Inspect interconnecting cable for wear.</li> </ul>
	5	2	2	Communication error between slave1 outdoor unit main PCB and inverter PCB.	
	5	2	3	Communication error between slave2 outdoor unit main PCB and inverter PCB.	
	5	3	1	Communication error between master outdoor unit main PCB and indoor unit(s) PCB.	<ul style="list-style-type: none"> <li>• Check if outdoor unit to indoor unit(s) communications cable disconnected or shorted.</li> <li>• Check A terminals are connected to indoor unit A(3) (5 on 3 x 3 cassette) terminals; B(4) (6 on 3 x 3 cassette) terminals.</li> </ul>
	5	3	2	Communication error between slave1 outdoor unit main PCB and indoor unit(s) PCB.	
	5	3	3	Communication error between slave2 outdoor unit main PCB and indoor unit(s) PCB.	
	5	7	1	Master outdoor unit main PCB and inverter PCB communication error.	Master outdoor unit inverter PCB is not receiving signal from main PCB.
	5	7	2	Slave1 outdoor unit main PCB and inverter PCB communication error.	Slave1 outdoor unit inverter PCB is not receiving signal from main PCB.
	5	7	3	Slave2 outdoor unit main PCB and inverter PCB communication error.	Slave2 outdoor unit inverter PCB is not receiving signal from main PCB.
	6	0	1	Master outdoor unit inverter PCB EEPROM error.	<ul style="list-style-type: none"> <li>• Verify the EEPROM is present and in the socket correctly.</li> <li>• Check if all pins are in and are not bent.</li> <li>• Check if notch in the chip lines up with the arrow on the socket.</li> </ul>
	6	0	2	Slave1 outdoor unit inverter PCB EEPROM error.	
	6	0	3	Slave2 outdoor unit inverter PCB EEPROM error.	
	6	2	1	High temperature at the master outdoor unit inverter heatsink.	System shut off because of high temperatures at the master outdoor unit inverter heatsink.
	6	2	2	High temperature at the slave1 outdoor unit inverter heatsink.	System shut off because of high temperatures at the slave1 outdoor unit inverter heatsink.
	6	2	3	High temperature at the slave2 outdoor unit inverter heatsink.	System shut off because of high temperatures at the slave2 outdoor unit inverter heatsink.
	6	5	1	Master outdoor unit inverter heatsink temperature sensor error.	<ul style="list-style-type: none"> <li>• Check the connection on the outdoor unit PCB.</li> <li>• Thermistor shorted or opened.</li> </ul>
	6	5	2	Slave1 outdoor unit inverter heatsink temperature sensor error.	<ul style="list-style-type: none"> <li>• Check for 12 V DC between 12 V and GND (red to black) for 5 V DC.</li> </ul>
	6	5	3	Slave2 outdoor unit inverter heatsink temperature sensor error.	<ul style="list-style-type: none"> <li>• Check the Signal to GND (white to black) and use correct chart from Troubleshooting section to compare with actual system temperature.</li> </ul>
	6	7	1	Master outdoor unit fan has locked up.	No airflow.
	6	7	2	Slave1 outdoor unit fan has locked up.	
	6	7	3	Slave2 outdoor unit fan has locked up	
	7	1	1	Master outdoor unit inverter CT sensor error.	Master outdoor unit is restricted.
	7	1	2	Slave1 outdoor unit inverter CT sensor error.	Slave1 outdoor unit is restricted.
	7	1	3	Slave2 outdoor unit inverter CT sensor error.	Slave2 outdoor unit is restricted.
	7	5	1	Master outdoor unit fan CT sensor error.	Master outdoor unit fan current detection (CT) sensor disconnected or shorted.
	7	5	2	Slave1 outdoor unit fan CT sensor error.	Slave1 outdoor unit fan current detection (CT) sensor disconnected or shorted.
	7	5	3	Slave2 outdoor unit fan CT sensor error.	Slave2 outdoor unit fan current detection (CT) sensor disconnected or shorted.

Error Codes

# ERROR CODE TABLES



**⚠ WARNING** Please refer to the Safety Precautions on pages 4-7 for more detail to prevent injury or death regarding the operation and service troubleshooting of the Multi V product.

Table 74: Error Codes, continued.

Error Code				Description	Details	
Outdoor Unit	7	7	1	Master outdoor unit fan overcurrent error.	Outdoor unit fan current is >10A (for 208-230V units) or 5A (for 460V units).	
	7	7	2	Slave1 outdoor unit fan overcurrent error.	Slave1 outdoor unit fan current is >10A (for 208-230V units) or 5A (for 460V units).	
	7	7	3	Slave2 outdoor unit fan overcurrent error.	Slave2 outdoor unit fan current is >10A (for 208-230V units) or 5A (for 460V units).	
	7	9	1	Master outdoor unit fan operation failure error.	Master outdoor unit fan is experiencing first position sensor failure.	
	7	9	2	Slave1 outdoor unit fan operation failure error.	Slave1 outdoor unit fan is experiencing first position sensor failure.	
	7	9	3	Slave2 outdoor unit fan operation failure error.	Slave2 outdoor unit fan is experiencing first position sensor failure.	
	8	6	1	Master outdoor unit main PCB onboard EEPROM error.	<ul style="list-style-type: none"> <li>• Verify the EEPROM is present and in the socket correctly.</li> <li>• Check if all pins are in and are not bent.</li> <li>• Check if notch in the chip lines up with the arrow on the socket.</li> </ul>	
	8	6	2	Slave1 outdoor unit main PCB onboard EEPROM error.		
	8	6	3	Slave2 outdoor unit main PCB onboard EEPROM error.		
	8	7	1	Master outdoor unit fan PCB EEPROM error.	<ul style="list-style-type: none"> <li>• Communication error between master outdoor unit fan MICOM and EEPROM.</li> <li>• Verify EEPROM is present and in the socket correctly.</li> </ul>	
	8	7	2	Slave1 outdoor unit fan PCB EEPROM error.	<ul style="list-style-type: none"> <li>• Communication error between slave1 outdoor unit fan MICOM and EEPROM.</li> <li>• Verify EEPROM is present and in the socket correctly.</li> </ul>	
	8	7	3	Slave2 outdoor unit fan PCB EEPROM error.	<ul style="list-style-type: none"> <li>• Communication error between slave2 outdoor unit fan MICOM and EEPROM.</li> <li>• Verify EEPROM is present and in the socket correctly.</li> </ul>	
	1	0	4	1	Communication error between master outdoor unit and slave outdoor units.	Master outdoor unit main PCB is not receiving signals from slave outdoor units.
	1	0	4	2	Communication error between slave1 outdoor unit and master and slave2 outdoor units.	Slave1 outdoor unit main PCB is not receiving signals from master and slave2 outdoor units.
	1	0	4	3	Communication error between slave2 outdoor unit and master and slave1 outdoor units.	Slave2 outdoor unit main PCB is not receiving signals from master and slave1 outdoor units.
	1	0	5	1	Master outdoor unit fan PCB to inverter compressor PCB communication error.	Master outdoor unit fan PCB did not receive signal from inverter compressor PCB.
	1	0	5	2	Slave1 outdoor unit fan PCB to inverter compressor PCB communication error.	Slave1 outdoor unit fan PCB did not receive signal from inverter compressor PCB.
	1	0	5	3	Slave2 outdoor unit fan PCB to inverter compressor PCB communication error..	Slave2 outdoor unit fan PCB did not receive signal from inverter compressor PCB.
	1	0	6	1	Master outdoor unit fan IPM error.	Instant overcurrent (peak) of master outdoor unit fan IPM.
	1	0	6	2	Slave1 outdoor unit fan IPM error.	Instant overcurrent (peak) of slave1 outdoor unit fan IPM.
	1	0	6	3	Slave2 outdoor unit fan IPM error.	Instant overcurrent (peak) of slave2 outdoor unit fan IPM.
1	0	7	1	Master outdoor unit fan DC link low voltage error.	<p>A capacitor that is serving the ODU fan inverter is not working properly, or the voltage at the capacitor is out of range (low). Start diagnosis at the inverter socket on the outdoor unit noise filter PCB</p> <ul style="list-style-type: none"> <li>• Outdoor unit fan DC link voltage is &lt;50V for a minimum of 250µs (for both 208-230V and 460V units).</li> <li>• Disconnected DC link.</li> <li>• Damaged electrical condenser component (serving capacitor) on inverter driver board.</li> </ul>	
1	0	7	2	Slave1 outdoor unit fan DC link low voltage error.		
1	0	7	3	Slave2 outdoor unit fan DC link low voltage error.		



**⚠ WARNING** Please refer to the Safety Precautions on pages 4-7 for more detail to prevent injury or death regarding the operation and service troubleshooting of the Multi V product.

Table 75: Error Codes, continued.

Error Code				Description	Details	
Outdoor Unit	1	1	3	1	Master outdoor unit liquid pipe temperature sensor error.	<ul style="list-style-type: none"> <li>• Check the connection on the outdoor unit PCB.</li> <li>• Thermistor shorted or opened.</li> <li>• Check for 12 V DC between 12 V and GND (red to black) for 5 V DC.</li> <li>• Check the Signal to GND (white to black) and use correct chart from Troubleshooting section to compare with actual system temperature.</li> </ul>
	1	1	3	2	Slave1 outdoor unit liquid pipe temperature sensor error.	
	1	1	3	3	Slave2 outdoor unit liquid pipe temperature sensor error.	
	1	1	4	1	Master outdoor unit subcooling inlet temperature sensor error.	
	1	1	4	2	Slave1 outdoor unit subcooling inlet temperature sensor error.	
	1	1	4	2	Slave2 outdoor unit subcooling inlet temperature sensor error.	
	1	1	5	1	Master outdoor unit subcooling outlet temperature sensor error.	
	1	1	5	2	Slave1 outdoor unit subcooling outlet temperature sensor error.	
	1	1	5	3	Slave2 outdoor unit subcooling outlet temperature sensor error.	
	1	1	6	1	Master outdoor unit low oil level or oil level sensor error.	<ul style="list-style-type: none"> <li>• Master outdoor unit may have low oil levels.</li> <li>• Master outdoor unit oil level sensor disconnected or shorted.</li> </ul>
	1	1	6	2	Slave1 outdoor unit oil level sensor error.	<ul style="list-style-type: none"> <li>• Slave1 outdoor unit may have low oil levels.</li> <li>• Slave1 outdoor unit oil level sensor disconnected or shorted.</li> </ul>
	1	1	6	3	Slave2 outdoor unit oil level sensor error.	<ul style="list-style-type: none"> <li>• Slave2 outdoor unit may have low oil levels.</li> <li>• Slave2 outdoor unit oil level sensor disconnected or shorted.</li> </ul>
	1	4	5	1	Communication error between master outdoor unit main board and external board.	Master outdoor unit main board to external board communication failure.
	1	4	5	2	Communication error between slave1 outdoor unit main board and external board.	Slave1 outdoor unit main board to external board communication failure.
	1	4	5	3	Communication error between slave2 outdoor unit main board and external board.	Slave2 outdoor unit main board to external board communication failure.
	1	5	0	1	Master outdoor unit compressor discharge superheat not satisfied.	<p>Code indicates that based on current superheat measurements, there is a high possibility of liquid refrigerant flooding back and damaging the compressor.</p> <ul style="list-style-type: none"> <li>• Outdoor unit compressor discharge superheat not satisfied for <math>\geq 5</math> minutes.</li> </ul>
	1	5	0	2	Slave1 outdoor unit compressor discharge superheat not satisfied.	<ul style="list-style-type: none"> <li>• Code can only occur when the outdoor is operating in cooling mode (all indoor units must be in cooling mode; error cannot occur during simultaneous operation).</li> <li>• After at least 10 minutes of compressor operation, the master outdoor unit microprocessor will calculate the system's compressor superheat. If at any time during compressor operation where all indoor units in thermal on are in cooling mode and the compressor superheat falls <math>&lt; 4.8^{\circ}\text{F}</math> (<math>&lt; 3^{\circ}\text{C}</math>) for <math>\geq 5</math> minutes, there is a high probability that liquid could flood back to the inlet of the compressor scroll, resulting in compressor damage.</li> </ul>
	1	5	0	3	Slave2 outdoor unit compressor discharge superheat not satisfied.	<ul style="list-style-type: none"> <li>• If error occurs 3 times within any 1 hour period of compressor operation, the system will shut down and remain off. A manual restart will be necessary.</li> </ul>
	1	5	1	1	Master outdoor unit difference between high and low pressure is too low.	Not enough pressure difference between high and low. Function error of outdoor unit four-way reversing valve (defective, disconnected, resistance is not $2,085\Omega \pm 10\%$ ).
	1	5	1	2	Slave1 outdoor unit difference between high and low pressure is too low.	
1	5	1	3	Slave2 outdoor unit difference between high and low pressure is too low.		

# ERROR CODE TABLES

**⚠ WARNING** Please refer to the Safety Precautions on pages 4-7 for more detail to prevent injury or death regarding the operation and service troubleshooting of the Multi V product.

Table 76: Error Codes, continued.

Error Code				Description	Details
1	5	3	1	Master outdoor unit upper heat exchanger temperature sensor error.	<ul style="list-style-type: none"> <li>• Check the connection on the outdoor unit PCB.</li> <li>• Thermistor shorted or opened.</li> <li>• Check for 12 V DC between 12 V and GND (red to black) for 5 V DC.</li> <li>• Check the Signal to GND (white to black) and use correct chart from Troubleshooting section to compare with actual system temperature.</li> </ul>
1	5	3	2	Slave1 outdoor unit upper heat exchanger temperature sensor error.	
1	5	3	3	Slave2 outdoor unit upper heat exchanger temperature sensor error.	
1	5	4	1	Master outdoor unit lower heat exchanger temperature sensor error.	
1	5	4	2	Slave1 outdoor unit lower heat exchanger temperature sensor error.	
1	5	4	3	Slave2 outdoor unit lower heat exchanger temperature sensor error.	
1	8	2	1	Communication error between master outdoor unit external board main and sub MICOMs.	Master outdoor unit external board main to sub MICOMs communication failure.
1	8	2	2	Communication error between slave1 outdoor unit external board main and sub MICOMs.	Slave1 outdoor unit external board main to sub MICOMs communication failure.
1	8	2	3	Communication error between slave2 outdoor unit external board main and sub MICOMs.	Slave2 outdoor unit external board main to sub MICOMs communication failure.
1	8	7	1	Hydro kit P, HEX error (P equals prevents from freezing).	<ul style="list-style-type: none"> <li>• Inlet water temperature is &lt;5°C (41°F). Raise error code – Level 3 response.</li> <li>• Water outlet temperature sensor is disconnected or shorted. Values read less than -43°C or greater than +96°C (less than -45.4°F or greater than +204.8°F).</li> <li>• Prevents HEX from bursting (from freezing) when operating. Does not protect HEX if the glycol is inadequate, nor if the hydro kit is off and not operating.</li> </ul> <p>Outdoor unit compressor ramps up, and hydro kit operates. One (1) minute later, pipe temperature at mid-temperature hot water supply (inlet or outlet water) is &lt;0°C (32°F), and mid-temperature hot water supply (inlet or outlet water) is ≤4°C (39.2°F) for ten (10) seconds.</p>
1	8	7	2		
1	8	7	3		
1	9	3	1	Excessive increase in master outdoor unit fan heatsink temperature.	<ul style="list-style-type: none"> <li>• System has shut off because outdoor unit fan heatsink temperature is &gt;203°F.</li> <li>• Check the connection on the outdoor unit PCB.</li> <li>• Thermistor shorted or opened.</li> <li>• Check for 12 V DC between 12 V and GND (red to black) for 5 V DC.</li> <li>• Check the Signal to GND (white to black) and use correct chart from Troubleshooting section to compare with actual system temperature.</li> </ul>
1	9	3	2	Excessive increase in slave1 outdoor unit fan heatsink temperature.	
1	9	3	3	Excessive increase in slave2 outdoor unit fan heatsink temperature.	
1	9	4	1	Master outdoor unit fan heatsink temperature sensor error.	<ul style="list-style-type: none"> <li>• Check the connection on the outdoor unit PCB.</li> <li>• Thermistor shorted or opened.</li> <li>• Check for 12 V DC between 12 V and GND (red to black) for 5 V DC.</li> <li>• Check the Signal to GND (white to black) and use correct chart from Troubleshooting section to compare with actual system temperature.</li> </ul>
1	9	4	2	Slave1 outdoor unit fan heatsink temperature sensor error.	
1	9	4	3	Slave2 outdoor unit fan heatsink temperature sensor error.	

**⚠ WARNING** Please refer to the Safety Precautions on pages 4-7 for more detail to prevent injury or death regarding the operation and service troubleshooting of the Multi V product.

Table 77: Error Codes, continued.

Error Code				Description	Details	
Heat Recovery Unit	-	5	1	C + No. of HR Unit	Capacity of indoor units connected to the heat recovery unit exceeds allowable limits.	<p>The amount of nominal cooling capacity of indoor units connected to a heat recovery unit, or a heat recovery unit port, or grouped heat recovery unit port is excessive. After auto-pipe detection is complete, wait 5 minutes, then verify connected capacity. System will display error if:</p> <ul style="list-style-type: none"> <li>• The heat recovery unit port addresses are all unique, then &gt;54 Mbh single indoor unit connected; &gt;54 Mbh total of multiple indoor units connected.</li> <li>• If 2 heat recovery unit port addresses are the same and the ports are twinned; &gt;108 Mbh total of multiple indoor units are connected.</li> <li>• If 3 heat recovery unit port addresses are the same and the ports are all connected, &gt;162 Mbh total of multiple indoor units connected.</li> <li>• If the total connected indoor unit nominal capacity exceeds 192 Mbh for a single heat recovery unit.</li> <li>• Error code displays on the outdoor unit SSD, the heat recovery unit SSD, or in LGMV.</li> </ul>
	2	0	0	1	Auto pipe search failure.	Auto piping procedure did not complete properly.
	2	0	1	C + No. of HR Unit	Heat recovery unit liquid sensor error. (C = Heat recovery unit + Heat recovery unit number).	Disconnection or short circuit of heat recovery unit liquid pipe sensor.
	2	0	2		Heat recovery unit subcooling pipe inlet sensor error. (C = Heat recovery unit + Heat recovery unit number).	Disconnection or short circuit of heat recovery unit subcooling pipe inlet sensor.
	2	0	3		Heat recovery unit subcooling pipe outlet sensor error. (C = Heat recovery unit + Heat recovery unit number).	Disconnection or short circuit of heat recovery unit subcooling pipe outlet sensor.
	2	0	4		Communication error between outdoor unit and heat recovery unit. (C = Heat recovery unit + Heat recovery unit number)	Outdoor unit does not receive signal from heat recovery unit.
	2	0	5		Communication error between heat recovery unit (2A Series) and the 485 modem. The 2A Series heat recovery unit applies only to heat recovery systems communicating at a baud rate of 9,600 bps. <ul style="list-style-type: none"> <li>• The 485 modem is the communications style on the bus that is an outdoor unit to many indoor units.</li> </ul>	<ul style="list-style-type: none"> <li>• Communication problem occurred between the heat recovery unit PCB and the connection to the communications bus (the heat recovery unit 485 modem).</li> <li>• Error displays if the outdoor unit signal is not received for three (3) minutes. The error clears after the signal is received from the modem. (2A Series Heat Recovery Units.)</li> </ul>
	2	0	6		Duplicate address error of the heat recovery unit (2A Series). <ul style="list-style-type: none"> <li>• The 2A Series heat recovery unit applies only to heat recovery systems communicating at a baud rate of 9,600 bps.</li> <li>• The 485 modem is the communications style on the bus that is an outdoor unit to many indoor units.</li> </ul>	<ul style="list-style-type: none"> <li>• A heat recovery unit address is duplicated for 485 communication.</li> <li>• There are two heat recovery units with one or more HEX addresses that are the same.</li> <li>• Adjust the hex address dial found on the heat recovery units.</li> </ul>
2	4	2	*		Network error of central controller.	Inability of the central controller to receive information from the outdoor unit.

Error Codes

# ERROR CODES

Error Nos. 01, 02, 06, and 17

**▲WARNING** Please refer to the Safety Precautions on pages 4-7 for more detail to prevent injury or death regarding the operation and service troubleshooting of the Multi V product.

Error No.	Description	Details	Causes
01	Indoor unit return air or optional remote wall temperature sensor communications error.	Sensor has disconnected or short circuited. Use the OHM and voltage check charts.	<ol style="list-style-type: none"> <li>1. Problem with the sensor.</li> <li>2. Connections on indoor unit PCB are wrong.</li> <li>3. Indoor unit PCB has failed.</li> </ol>
01 (Fresh Air Unit [FAU])	Fresh air unit outlet air sensor error.		
02	Indoor unit inlet pipe temperature sensor communication error.		
06	Indoor unit or hydro kit outlet pipe temperature sensor error.		<ol style="list-style-type: none"> <li>1. Indoor unit outlet pipe temperature sensor is disconnected or shorted. (Check the connection on the indoor unit PCB, then check the thermistor.)</li> <li>2. Hydro kit liquid side temperature sensor is disconnected or shorted. Values read less than <math>-43^{\circ}\text{C}</math> or greater than <math>+96^{\circ}\text{C}</math> (less than <math>-45.4^{\circ}\text{F}</math> or greater than <math>+204.8^{\circ}\text{F}</math>).</li> </ol>
16	Hydro kit indoor unit water pipe temperature and ambient temperature sensor communication error.		Water inlet and outlet pipe temperature sensor disconnected, shorted, or opened.
17	Hydro kit inlet pipe temperature sensor communication error. Outside air duct inlet pipe temperature sensor communication error.	<ol style="list-style-type: none"> <li>1. Water inlet temperature sensor disconnected or shorted. Values read less than <math>-43^{\circ}\text{C}</math> or greater than <math>+96^{\circ}\text{C}</math> (less than <math>-45.4^{\circ}\text{F}</math> or greater than <math>+204.8^{\circ}\text{F}</math>).</li> <li>2. Temperature sensor disconnected, shorted, or opened.</li> </ol>	

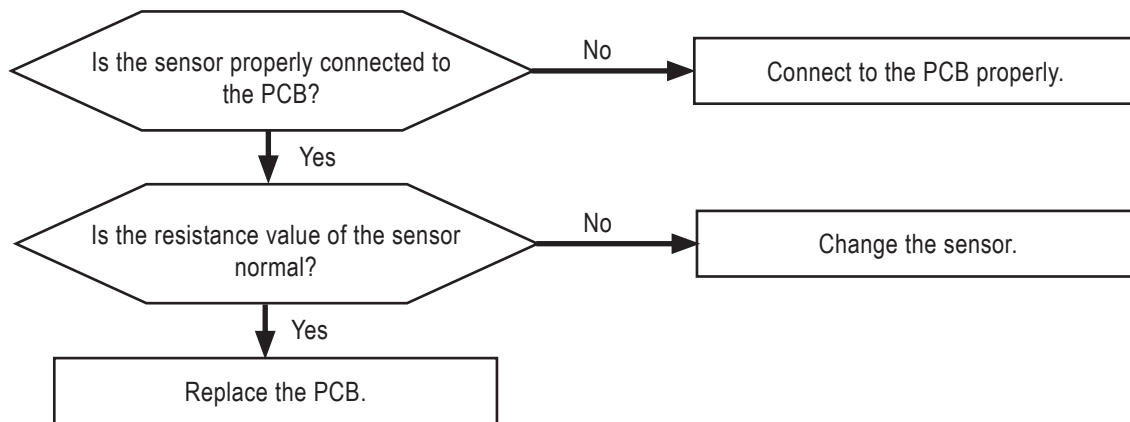

← CN-ROOM: Indoor Air Temperature Sensor  
 ← CN-PIPE IN: Pipe Inlet Temperature Sensor  
 ← CN-PIPE OUT: Pipe Outlet Temperature Sensor



Measure the resistance of outlet pipe temperature sensor.

- If the value is  $>100\text{k}\Omega$  (open) or  $<100\Omega$  (short), there is an error.
- Sensor resistance value will vary with the temperature. See below for the resistance values according to temperature ( $\pm 5\%$  tolerance).
- Air temperature sensor:  $50^{\circ}\text{F} = 20.7\text{ k}\Omega$ ,  $77^{\circ}\text{F} = 10\text{ k}\Omega$ ,  $122^{\circ}\text{F} = 3.4\text{ k}\Omega$ .
- Pipe temperature sensor:  $50^{\circ}\text{F} = 10\text{ k}\Omega$ ,  $77^{\circ}\text{F} = 5\text{ k}\Omega$ ,  $122^{\circ}\text{F} = 1.8\text{ k}\Omega$ .

**⚠ WARNING** Please refer to the Safety Precautions on pages 4-7 for more detail to prevent injury or death regarding the operation and service troubleshooting of the Multi V product.

Error No.	Description	Details	Causes
03	Communication error between zone controller and indoor unit	Indoor unit PCB has not received communications signal from zone controller.	<ol style="list-style-type: none"> <li>1. Zone controller error.</li> <li>2. Indoor unit PCB error.</li> <li>3. Connection error or connection wrong.</li> <li>4. Transmission cable error.</li> </ol>

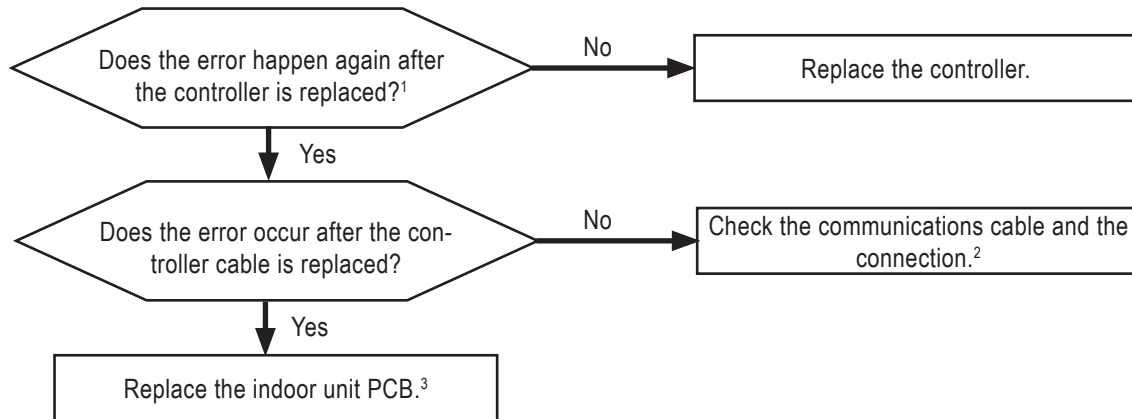

<sup>1</sup>If there isn't a controller to replace, use an operating controller from another indoor unit.

<sup>2</sup>Plug the controller directly into the indoor unit PCB. If the error code does not come back after several minutes, the cable needs to be replaced. Check the cable because the connection could be in error. Check for cable extensions. Check distances between the communication cable and main electrical wiring. Ensure that the cable and wiring are at safe distances from one another to avoid being affected by electromagnetic waves.

<sup>3</sup>After replacing the indoor unit PCB, perform the auto addressing procedure, and input unit address if system includes a controller. (All connected indoor units must be turned ON before initiating the auto addressing procedure.)



CN-REMO: Remote controller connection

\* The PCB can differ from model to model.

### Note:

Images here are representative of system components. Actual component appearance depends on model and system type.



Checking communication cable connection

# ERROR CODES

## Error No. 04

**⚠ WARNING** Please refer to the Safety Precautions on pages 4-7 for more detail to prevent injury or death regarding the operation and service troubleshooting of the Multi V product.

Error No.	Description	Details	Causes
04	Indoor unit drain overflow error.	Drain pump and / or float switch could be malfunctioning. Also check if the drain line is obstructed.	<ol style="list-style-type: none"> <li>1. Drain pump / float switch error.</li> <li>2. Improper drain pipe location, clogged drain pipe.</li> <li>3. Indoor unit PCB error.</li> </ol>

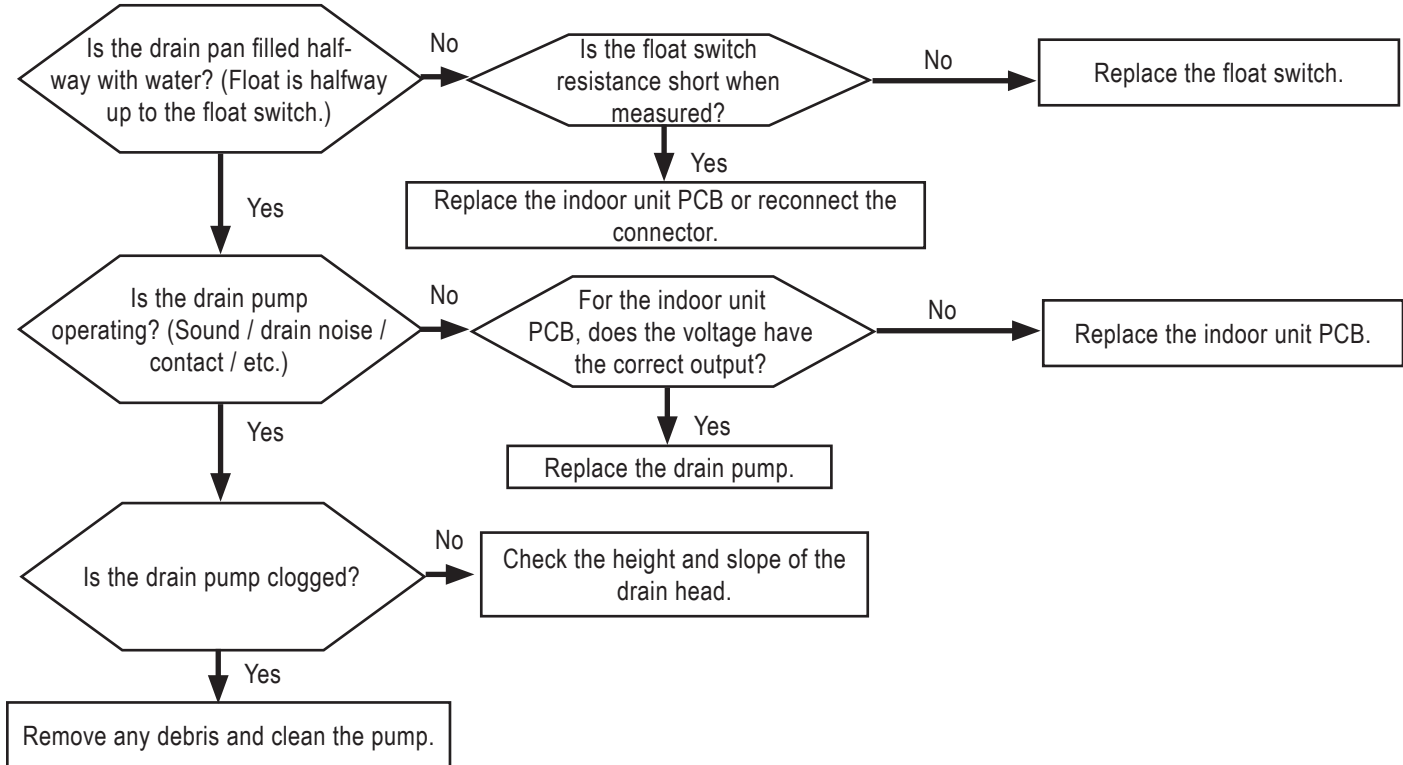

MULTI V 5 Outdoor Unit Service Manual

\* If the float rises higher than half its height, then the circuit opens and the unit automatically stops.

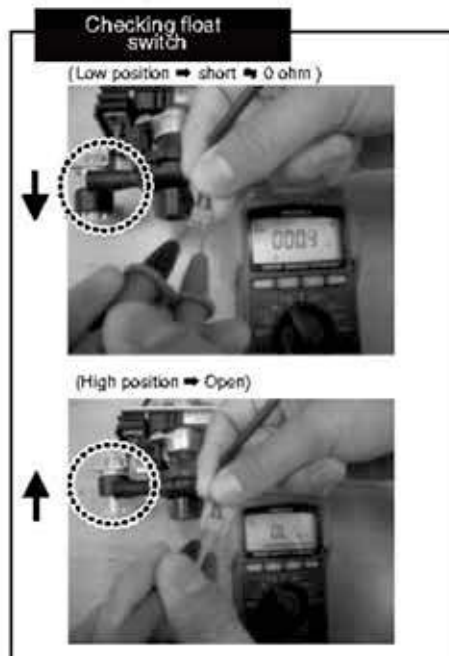
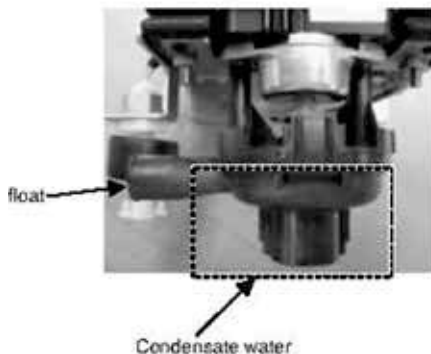

### Note:

Images here are representative of system components. Actual component appearance depends on model and system type.

Error No. 04, continued.



**WARNING** Please refer to the Safety Precautions on pages 4-7 for more detail to prevent injury or death regarding the operation and service troubleshooting of the Multi V product.

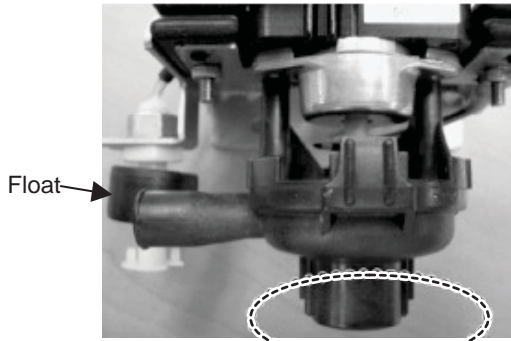

A: Point to Check Rotation



\*\* Indoor PCB Drain Pump Connector  
(Check Electrical Input; Marked as CN-DPUMP)

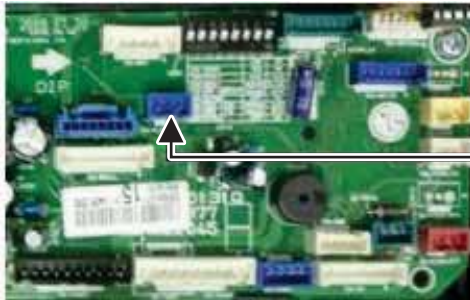

Float Switch Housing (CN-FLOAT)

**Note:**

*Images here are representative of system components. Actual component appearance depends on model and system type.*

Standard Drain Pipe Height / Slope.

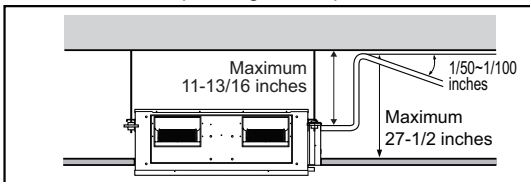

# ERROR CODES

## Error No. 05

**⚠ WARNING** Please refer to the Safety Precautions on pages 4-7 for more detail to prevent injury or death regarding the operation and service troubleshooting of the Multi V product.

Error No.	Description	Details	Causes
05	Communication error between outdoor unit PCB and indoor unit PCB.	Indoor unit PCB is not receiving communications signal from outdoor unit PCB for more than 5 minutes. Check indoor unit PCB for issues.	<ol style="list-style-type: none"> <li>1. Auto addressing has not been performed properly.</li> <li>2. Communication cable is not connected.</li> <li>3. Communication cable is short circuiting.</li> <li>4. Indoor unit communication circuit error.</li> <li>5. Outdoor unit communication circuit error.</li> <li>6. Not enough physical distance between power wiring and communication cables.</li> <li>7. T-phase line disconnection.</li> </ol>

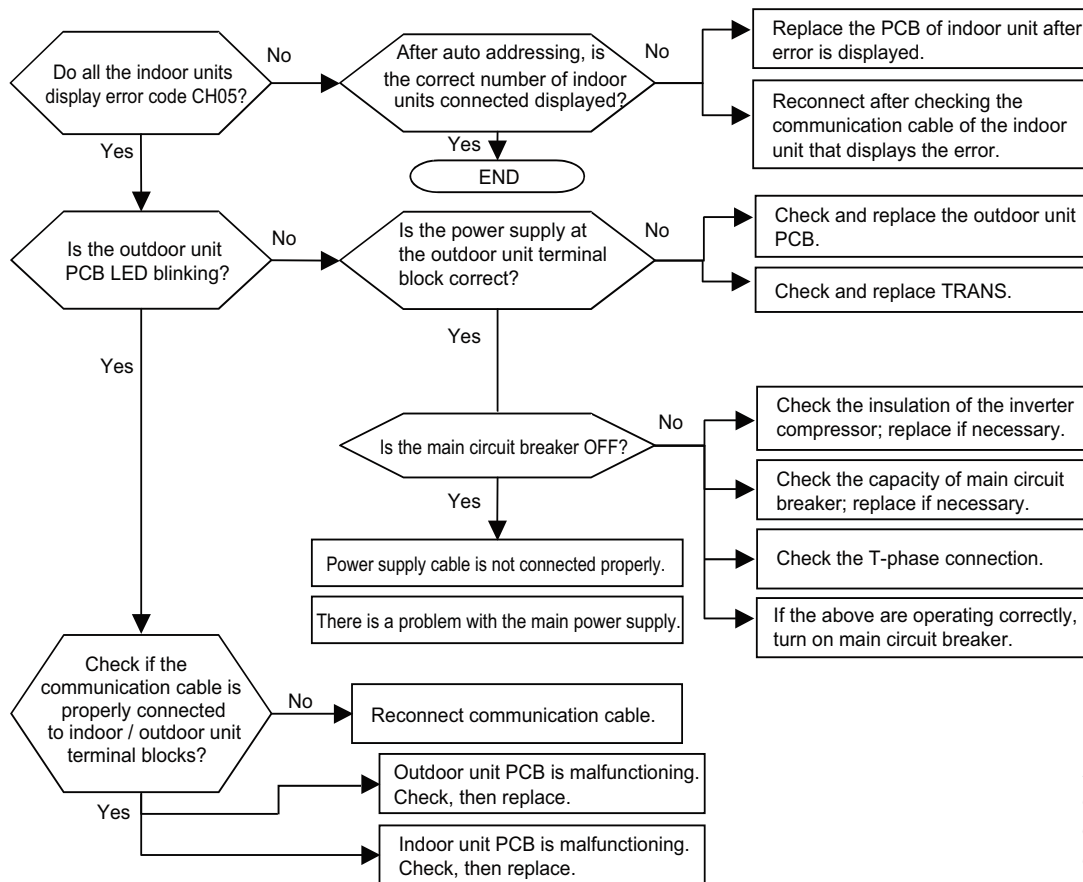

### Note:

Images here are representative of system components. Actual component appearance depends on model and system type.

Communication from the indoor unit is normal if voltage fluctuation (-9V ~ +9V) exists (when checking DC voltage of the communication terminal between the indoor and outdoor units).



If the DC voltage between communication terminal A, B of indoor unit fluctuates within -9V ~ +9V, then the communication from the outdoor unit is normal.

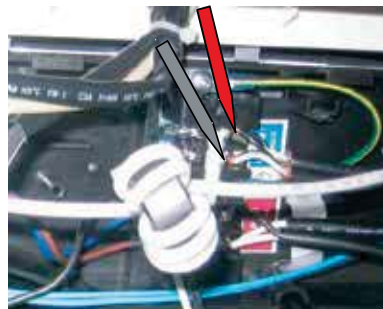

### Note:

See also Error Code No. 237: RS-485 Communication Error Between Indoor Unit and Outdoor Unit, and Error Code No. 238: Outdoor Unit PCB Communication Error Between Indoor Unit and Outdoor Unit.

**⚠ WARNING** Please refer to the Safety Precautions on pages 4-7 for more detail to prevent injury or death regarding the operation and service troubleshooting of the Multi V product.

Error No.	Description	Details	Causes
09	Indoor unit EEPROM error.	<ul style="list-style-type: none"> <li>Serial number on EEPROM of indoor unit is 0 or FFFFFFFF.</li> <li>Communication error between MICOM and EEPROM.</li> <li>Indoor unit PCB EEPROM is in error or data is not available.</li> </ul>	<ol style="list-style-type: none"> <li>Error developed in transmission between the microprocessor and the EEPROM on the indoor unit PCB.</li> <li>EEPROM is damaged.</li> </ol>

Replace the indoor unit PCB, perform the Auto Addressing procedure, and input the central control address.

# ERROR CODES

## Error No. 10

**⚠ WARNING** Please refer to the Safety Precautions on pages 4-7 for more detail to prevent injury or death regarding the operation and service troubleshooting of the Multi V product.

Error No.	Description	Details	Causes
10	Indoor unit BLDC fan motor communications error.	Indoor BLDC fan motor feedback signal has been absent for at least 50 seconds.	<ol style="list-style-type: none"> <li>1. Fan motor connector has been disconnected, removed, or malfunctioned.</li> <li>2. Indoor fan motor lock has failed.</li> <li>3. Indoor PCB error.</li> </ol>

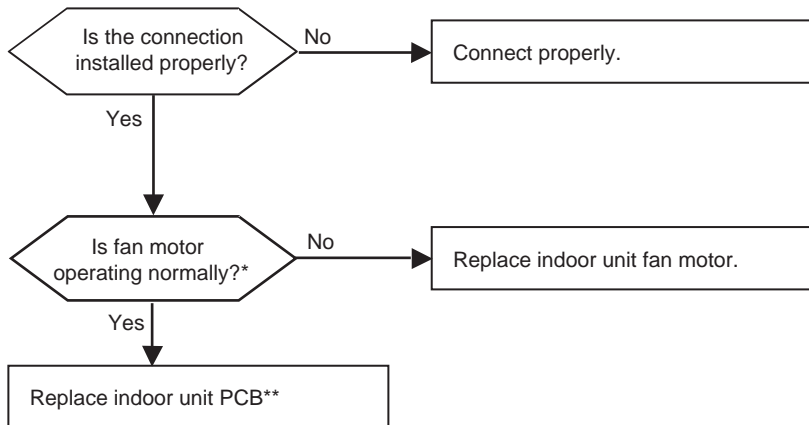

\*The indoor unit fan motor hall sensor is operating normally when the values measured are as shown below.



Measure Each Terminal with the Tester

Tester		Normal Resistance (±10%)	
+	-		
①	④	∞	∞
⑤	④	Hundreds kΩ	Hundreds kΩ
⑥	④	∞	∞
⑦	④	Hundreds kΩ	Hundreds kΩ

Checking the Fan Motor Connections



### Note:

Images here are representative of system components. Actual component appearance depends on model and system type.

\*\* Replace the indoor unit PCB, perform the Auto Addressing procedure, and then input the central control address.

### ⚠ WARNING

Check the fan motor connection to the PCB only when power is OFF. Electrical shock can cause physical injury or death.

**⚠ WARNING** Please refer to the Safety Precautions on pages 4-7 for more detail to prevent injury or death regarding the operation and service troubleshooting of the Multi V product.

### Dismantling / Servicing the Control Box and Inverter PCB

#### Note:

- Do not remove the heat sink assembly before detaching the middle bracket screws.
- Use care when detaching the heat sink assembly. Do not apply excessive force. Applying excessive force will damage the heat sink assembly and will cause the unit to malfunction.

#### Dismantling / Servicing the Control Box

1. Remove the control box cover.
2. Remove the middle bracket screws.
3. Gently detach the heat sink assembly from the control box.
4. Disconnect the fan lead wire from the control box, and detach the compressor lead wires from the compressors.
5. Detach the outer screws, and then remove the control box assembly from the outdoor unit.
6. To reassemble the control box, follow Steps 5 through 1 above.

#### Note:

Heat transfer paste at the heat sink is required. For instructions, see "Replacing the Inverter PCB Heat Sink" page later in this section.

#### Dismantling / Servicing the Inverter PCB

1. Detach the four (4) thermal pad mounting screws at the left side of the control box.
2. Disconnect the compressor (U/V/W) and the power input (R/S/T) lead wiring.
3. Detach the two (2) middle IGBT mounting screws.
4. Remove the Inverter PCB from the control box assembly.
5. Remove the PCB from the corner supports.
6. To reassemble the Inverter PCB, follow Steps 5 through 1 above.

#### Note:

- Only use a JIS screwdriver. A standard Phillips screwdriver will damage / strip the inverter PCB screw heads.
- Heat transfer paste at the heat sink is required. For instructions, see "Replacing the Inverter PCB Heat Sink" page later in this section.
- Carefully reconnect the wires with out interchanging the locations.

#### ⚠ WARNING

Dismantle the Control Box and Inverter PCB only when power is OFF. Electrical shock can cause physical injury or death.

#### Note:

Images here are representative of system components. Actual component appearance depends on model and system type.

Figure 64: Detaching the Middle Bracket Screws.

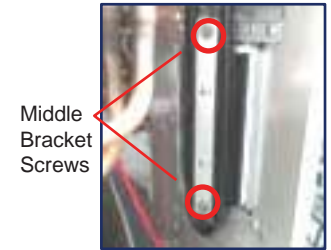

Heat Sink Assembly

Figure 65: Removing the Control Box Cover.



Figure 66: Removing the Middle Bracket Screws.

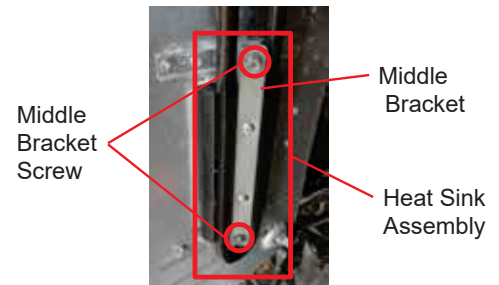

Figure 67: Detaching the Mounting Screws.



Figure 68: Disconnecting the Compressor and Power Input Wiring.



Figure 69: Detaching the IGBT Screws.



Figure 70: Removing the Inverter PCB.



Figure 71: Removing the PCB.



# ERROR CODES

## Error No. 21

**WARNING** Please refer to the Safety Precautions on pages 4-7 for more detail to prevent injury or death regarding the operation and service troubleshooting of the Multi V product.

Error No.	Description	Details	Causes
21 Master: 211 Slave 1: 212 Slave 2: 213	Outdoor unit inverter board IPM fault error.	<ul style="list-style-type: none"> <li>Inverter driver detects overcurrent (CT sensor on the IGBTM PCB).</li> <li>Error code is determined by overcurrent in any one phase of compressor.</li> </ul>	<ol style="list-style-type: none"> <li>Detected by the CT sensor on the IGBT PCB.</li> <li>Overcurrent in compressor U-V-W phases.</li> <li>Damaged compressor.</li> <li>Damaged IPM on inverter board.</li> <li>Compressor disconnected.</li> <li>Damaged or disconnected cooling fan.</li> <li>Damaged inverter board – input voltage too low. For 208-230V: On 068 compressors = 143A for a minimum of 3μs; on 048 compressors = 96A for a minimum of 3μs. For 460V: On 068 compressors = 80 A for a minimum of 3μs; On 048 compressors = 56A for a minimum of 3μs. Also, see tables below.</li> </ol>

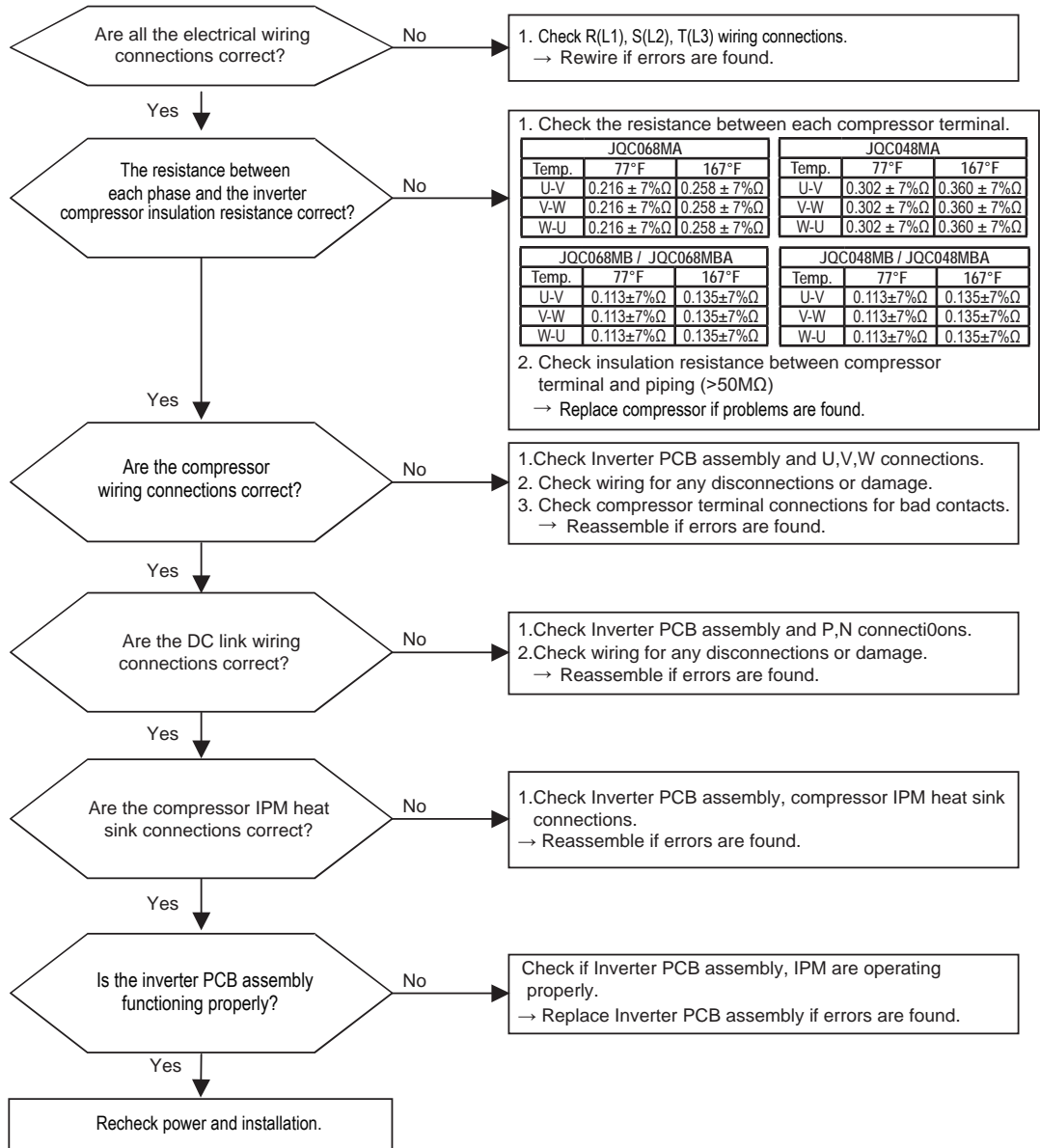

**Note:**

See the "Checking the Inverter Insulated-Gate Bipolar Transistor Module" and the "Checking the Phase Diode Bridge" pages in the "Troubleshooting Main Components" section.

**Note:**

Always apply heat transfer paste to the new inverter PCB heat sink before installing. For instructions, see "Replacing the Inverter PCB Heat Sink" page later in this section.

**⚠ WARNING** Please refer to the Safety Precautions on pages 4-7 for more detail to prevent injury or death regarding the operation and service troubleshooting of the Multi V product.

Measuring the resistance between each compressor terminal.



P and N Terminals.

Compressor wiring connections.

\* Heat Sink Screws.

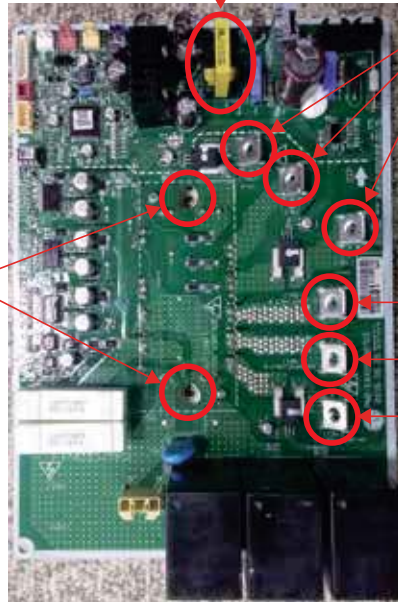

R

S

T

Check DC link connections.

**Note:**

Images here are representative of system components. Actual component appearance depends on model and system type.

Table 78: Error No. 21 Checkpoint Details.

Cause	Check	Checklist				App.
		Check Point	Normal	Abnormal	Defective Parts	
Under Voltage (15V)	15V Voltage Measurement (Inverter connector)	Voltage	14.5V ~ 15.5V	14V ↓	Inverter PCB	A2 (Power ON)
Inverter PCB Damaged	Check Inverter PCB appearance	Appearance	Good	Damage	Inverter PCB	B1 (Power Off)
	Measure 5V, 15V line	5V, 15V Resistance	10kΩ↑	1kΩ↓ ~ 0Ω		
	IGBTM (Check IGBT)	P-U, V, W / N-U, V, W	0.38V ~ 0.7V	Non-normal		
	Inverter Drive Circuit (Check diode)	Diode	0.38V ~ 0.7V	Non-normal		

Figure 72: Two Compressor Additional Check Procedure (Same Capacity Inverter Only).

Standard Connection.

Example: Inverter 1, CH21 displayed.

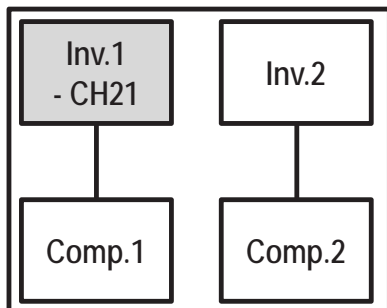

Cross Connections after Operation.

If Inverter 2 has CH21 displayed, then Comp. 1 is defective.

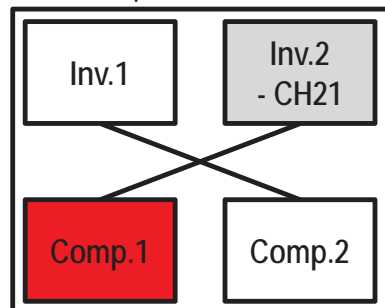

If Inverter 1 consistently displays CH21, then Inverter 1 is defective.

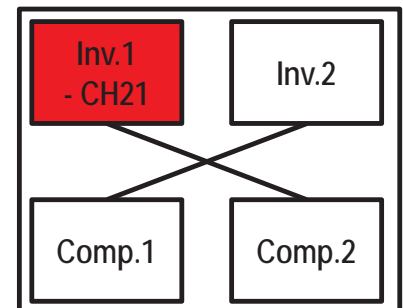

or

# ERROR CODES

## Error No. 22

**WARNING** Please refer to the Safety Precautions on pages 4-7 for more detail to prevent injury or death regarding the operation and service troubleshooting of the Multi V product.

Error No.	Description	Details	Causes
22 Master: 221 Slave 1: 222 Slave 2: 223	Outdoor unit AC inverter board input overcurrent (RMS) error.	The three-phase input power current for the inverter PCB assembly is >22A.	<ol style="list-style-type: none"> <li>1. Overload: Pipe has been clogged, EEV is defective, indoor or outdoor unit is blocked, there has been an overcharge in refrigerant.</li> <li>2. Compressor motor or insulation has been damaged.</li> <li>3. Input voltage is low.</li> <li>4. Improper connections in the power wiring.</li> <li>5. Inverter PCB assembly has been damaged (input current sensor).</li> </ol>

MULTI V 5 Outdoor Unit Service Manual

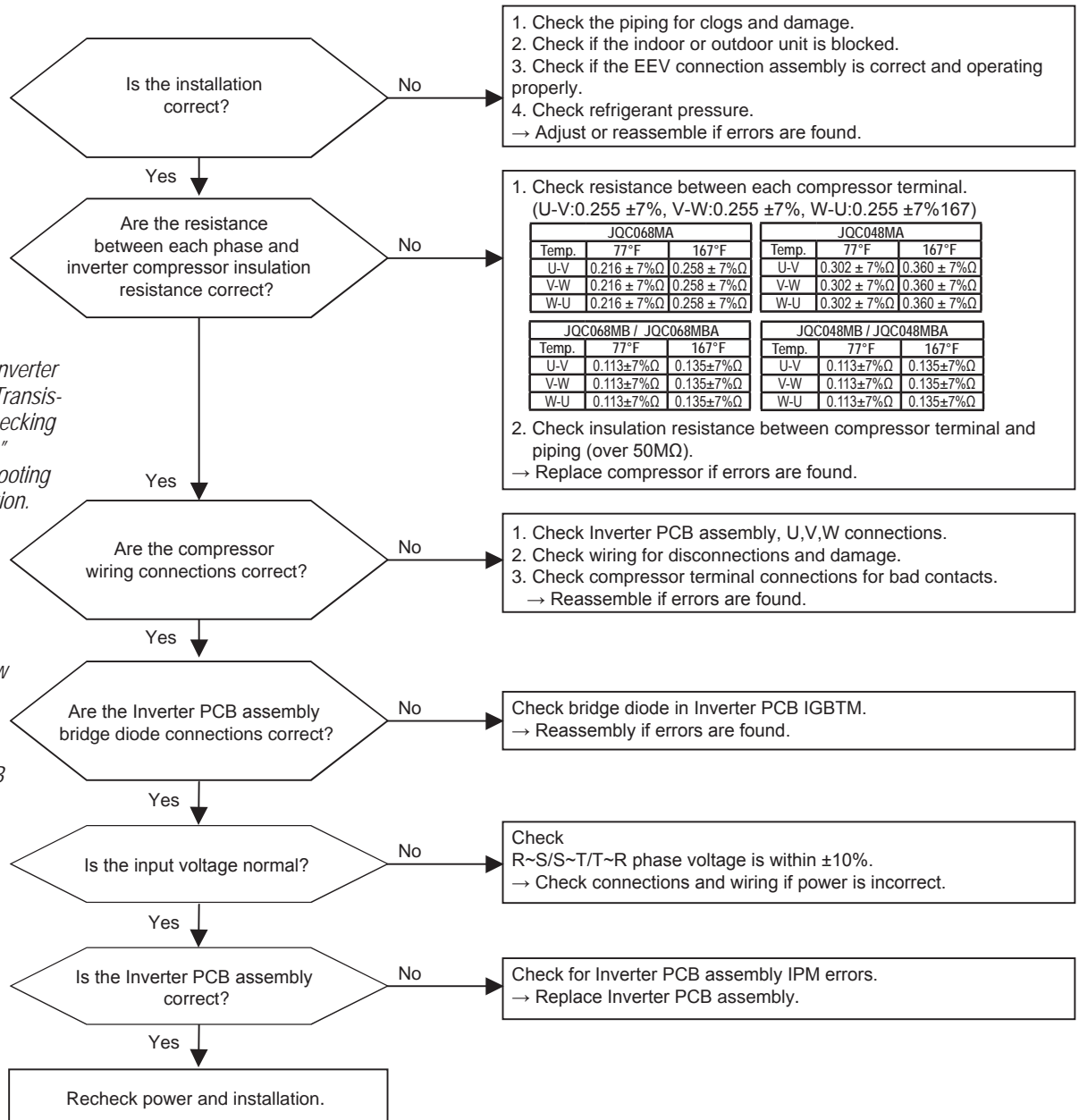

**Note:**

See the "Checking the Inverter Insulated-Gate Bipolar Transistor Module" and the "Checking the Phase Diode Bridge" pages in the "Troubleshooting Main Components" section.

**Note:**

Always apply heat transfer paste to the new inverter PCB heat sink before installing. For instructions, see "Replacing the Inverter PCB Heat Sink" page later in this section.

**⚠ WARNING** Please refer to the Safety Precautions on pages 4-7 for more detail to prevent injury or death regarding the operation and service troubleshooting of the Multi V product.

Measure resistance between compressor terminals.



Measure input voltage.



### Note:

Images here are representative of system components. Actual component appearance depends on model and system type.

Compressor wiring connections.

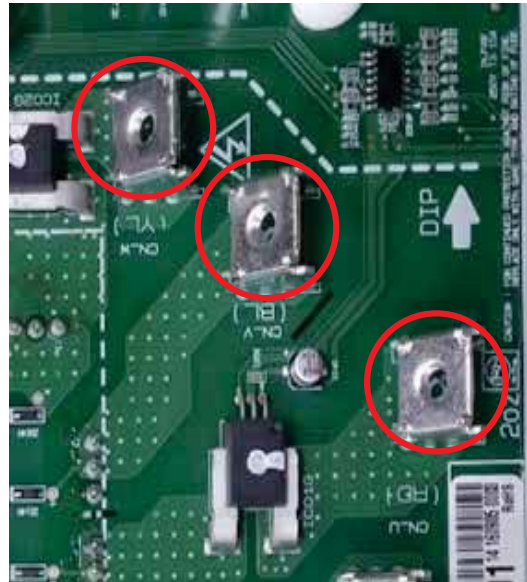

# ERROR CODES

## Error No. 23

**⚠ WARNING** Please refer to the Safety Precautions on pages 4-7 for more detail to prevent injury or death regarding the operation and service troubleshooting of the Multi V product.

Error No.	Description	Details	Causes
23 Master: 231 Slave 1: 232 Slave 2: 233	Low DC voltage sensed at the outdoor unit inverter compressor DC link.	System shut off because the DC link voltage fell below 50V (for both 208-230V and 460V units), or exceeded 550V (for 208-230V units) or 1,000V (for 460V units) for a minimum of 250µs.	<ol style="list-style-type: none"> <li>1. Start diagnosis at the inverter socket on the outdoor unit noise filter PCB.</li> <li>2. There is a capacitor that is not working properly, or the voltage at the capacitor is out of range (either high or low).</li> <li>3. Disconnected DC link.</li> <li>4. Damaged electrical condenser component (servicing capacitor) on inverter driver board.</li> </ol>

Check DC link connections.



DC Link Connector

Measure input voltage.



### Note:

Images here are representative of system components. Actual component appearance depends on model and system type.

### Note:

See the "Checking the Inverter Insulated-Gate Bipolar Transistor Module" and the "Checking the Phase Diode Bridge" pages in the "Troubleshooting Main Components" section.

### Note:

Always apply heat transfer paste to the new inverter PCB heat sink before installing. For instructions, see "Replacing the Inverter PCB Heat Sink" page later in this section.

Table 79: Error No. 23 Checkpoint Details.

Cause	Check	Checklist				App.	
		Check Point	Normal	Abnormal	Defective Parts		
Input Voltage Abnormal	Check Input Voltage	Voltage	3P3W, 220V	220V ± 15%	Non-normal	Input Voltage	A1 (Power ON)
			3P3W, 460V	460V ± 15%			
DC Link Power Abnormal	Check DC Link Voltage	Voltage	3P3W, 220V	310V±20%	140V↓, 420V↑	Converter PCB	A3 (Power ON and Compressor operating)
			3P3W, 460V	650V±20%	300V↓, 780V↑		
Converter PCB damaged	Check Converter PCB Appearance	Appearance	Good	Damage	Converter PCB	B2 (Power Off)	
	Measure 5V, 15V line	5V, 15V Resistance	10kΩ↑	1kΩ↓ ~ 0Ω			
	Check Bridge Diode	P-R,S,T / N-R,S,T	0.38V ~ 0.7V	Non-normal			

**⚠ WARNING** Please refer to the Safety Precautions on pages 4-7 for more detail to prevent injury or death regarding the operation and service troubleshooting of the Multi V product.

Error No.	Description	Details	Causes
24 Master: 241 Slave 1: 242 Slave 2: 243	System has been turned off by the outdoor unit high pressure switch.	Outdoor unit high pressure switch error. Excessive increase in outdoor unit compressor discharge pressure.	<ol style="list-style-type: none"> <li>1. Outdoor unit high pressure switch is defective.</li> <li>2. Indoor unit fan or outdoor unit fan is / are defective.</li> <li>3. Compressor check valve is clogged.</li> <li>4. Pipe has been damaged.</li> <li>5. Overcharge of refrigerant.</li> <li>6. Defective EEV at the indoor or outdoor unit.</li> <li>7. Outdoor unit is blocked during cooling mode; indoor unit filter is clogged during heating mode.</li> <li>8. Service valve is clogged.</li> <li>9. Outdoor unit PCB is defective.</li> <li>10. Check connection on the outdoor unit PCB.</li> <li>11. Active path valve is defective.</li> <li>12. Use chart in Troubleshooting section of the manual to check signal output (V DC) versus actual pressure.</li> </ol>

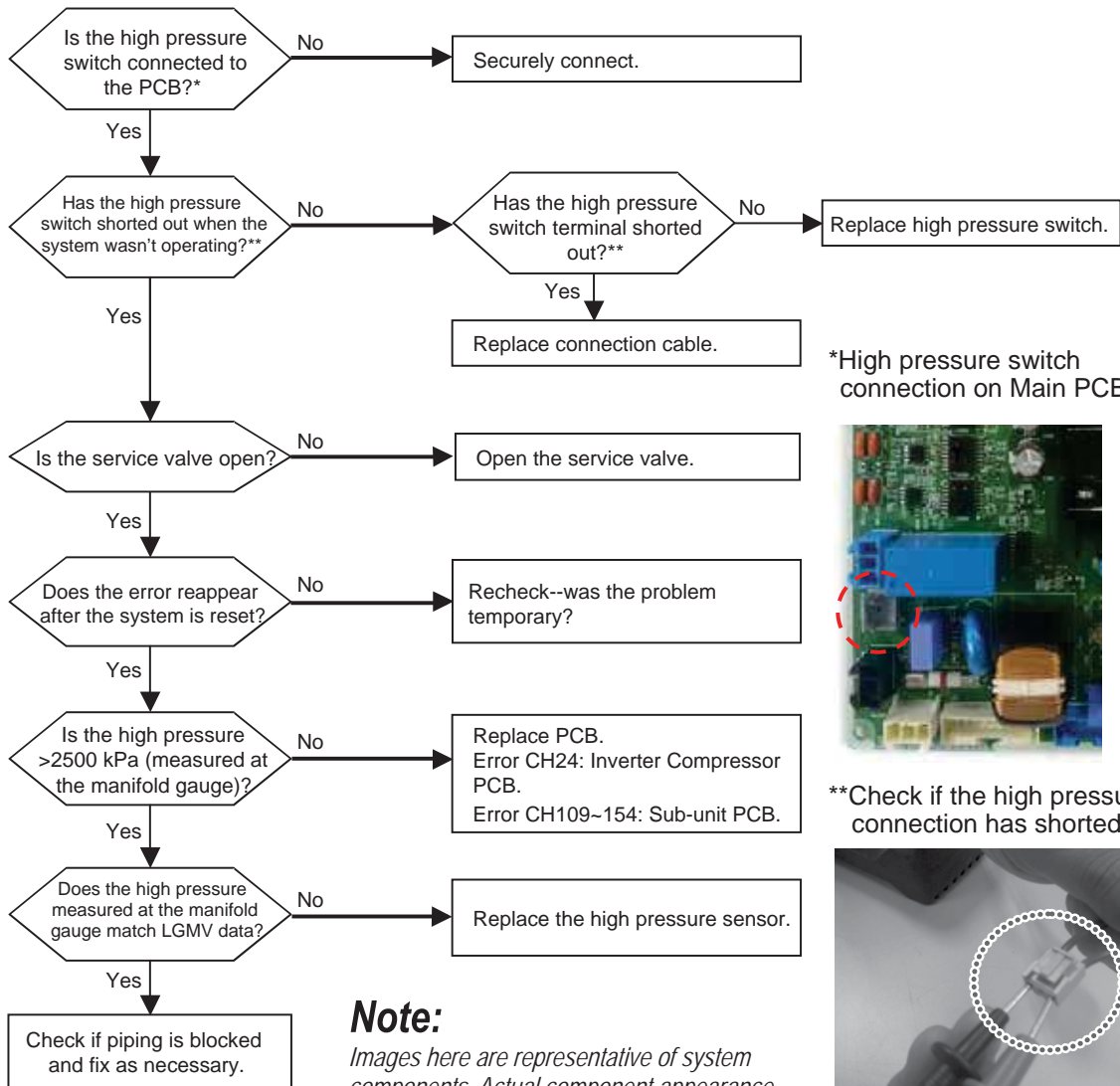

\*High pressure switch connection on Main PCB.



\*\*Check if the high pressure switch connection has shorted out.

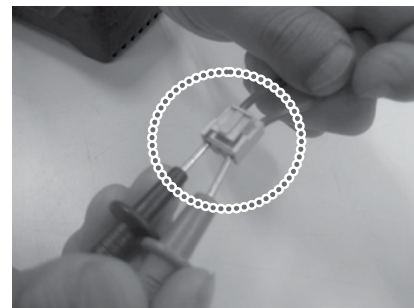

**Note:**  
Images here are representative of system components. Actual component appearance depends on model and system type.

# ERROR CODES

## Error No. 25

**⚠ WARNING** Please refer to the Safety Precautions on pages 4-7 for more detail to prevent injury or death regarding the operation and service troubleshooting of the Multi V product.

Error No.	Description	Details	Causes
25 Master: 251 Slave 1: 252 Slave 2: 253	Input voltage to the outdoor unit is too high or too low.	Outdoor unit has an input voltage of <180V or >253V (for 208-230V units), or an input voltage of <414V or >528V (for 460V units).	<ol style="list-style-type: none"> <li>1. Input voltage is abnormal.</li> <li>2. Outdoor unit inverter PCB assembly is damaged (input voltage sensor component).</li> </ol>

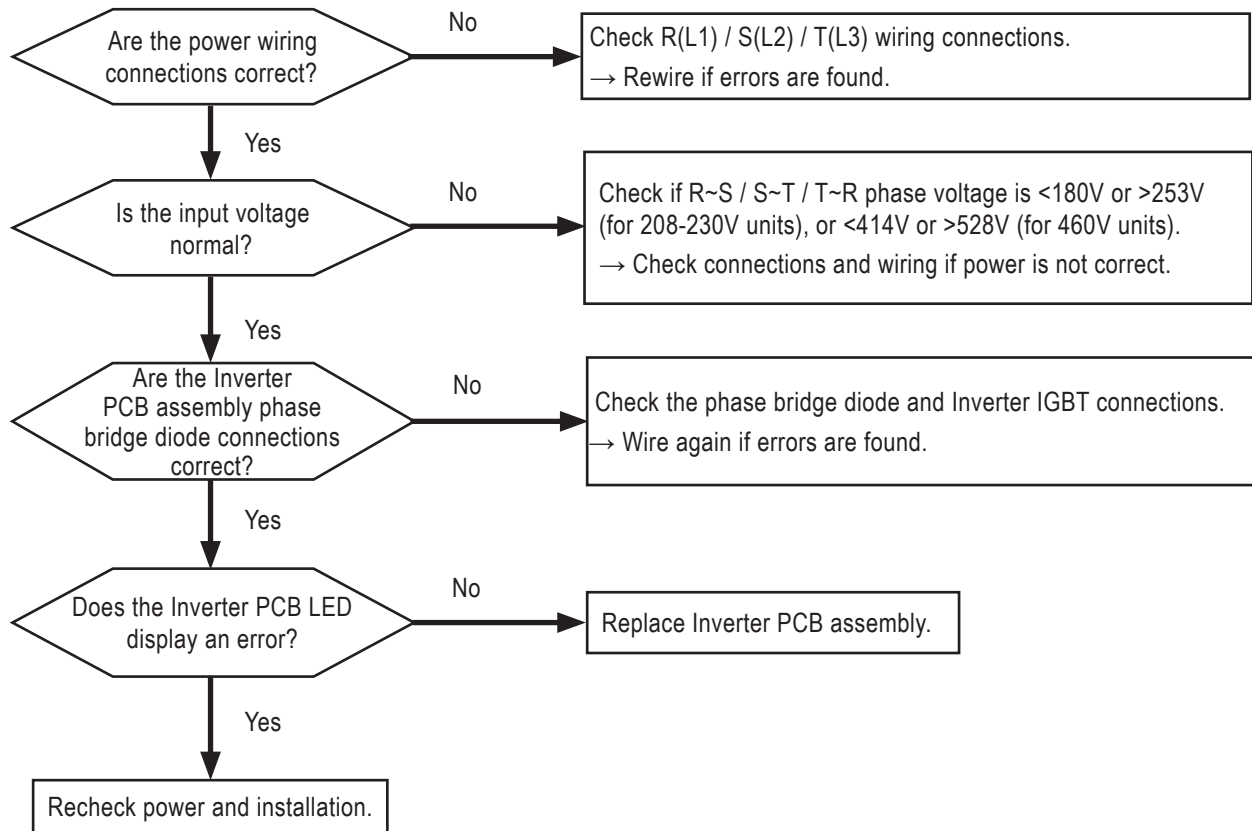

**WARNING** Please refer to the Safety Precautions on pages 4-7 for more detail to prevent injury or death regarding the operation and service troubleshooting of the Multi V product.

Error No.	Description	Details	Causes
26 Master: 261 Slave 1: 262 Slave 2: 263	Outdoor unit inverter compressor operation error.	Inverter compressor start failure.	<ol style="list-style-type: none"> <li>1. Overload error: Piping is clogged, indoor or outdoor unit is blocked, EEV is blocked, or there is an overcharge in refrigerant.</li> <li>2. Compressor insulation and / or motor has been damaged.</li> <li>3. Compressor wiring error.</li> <li>4. Outdoor unit inverter PCB has been damaged (CT).</li> </ol>

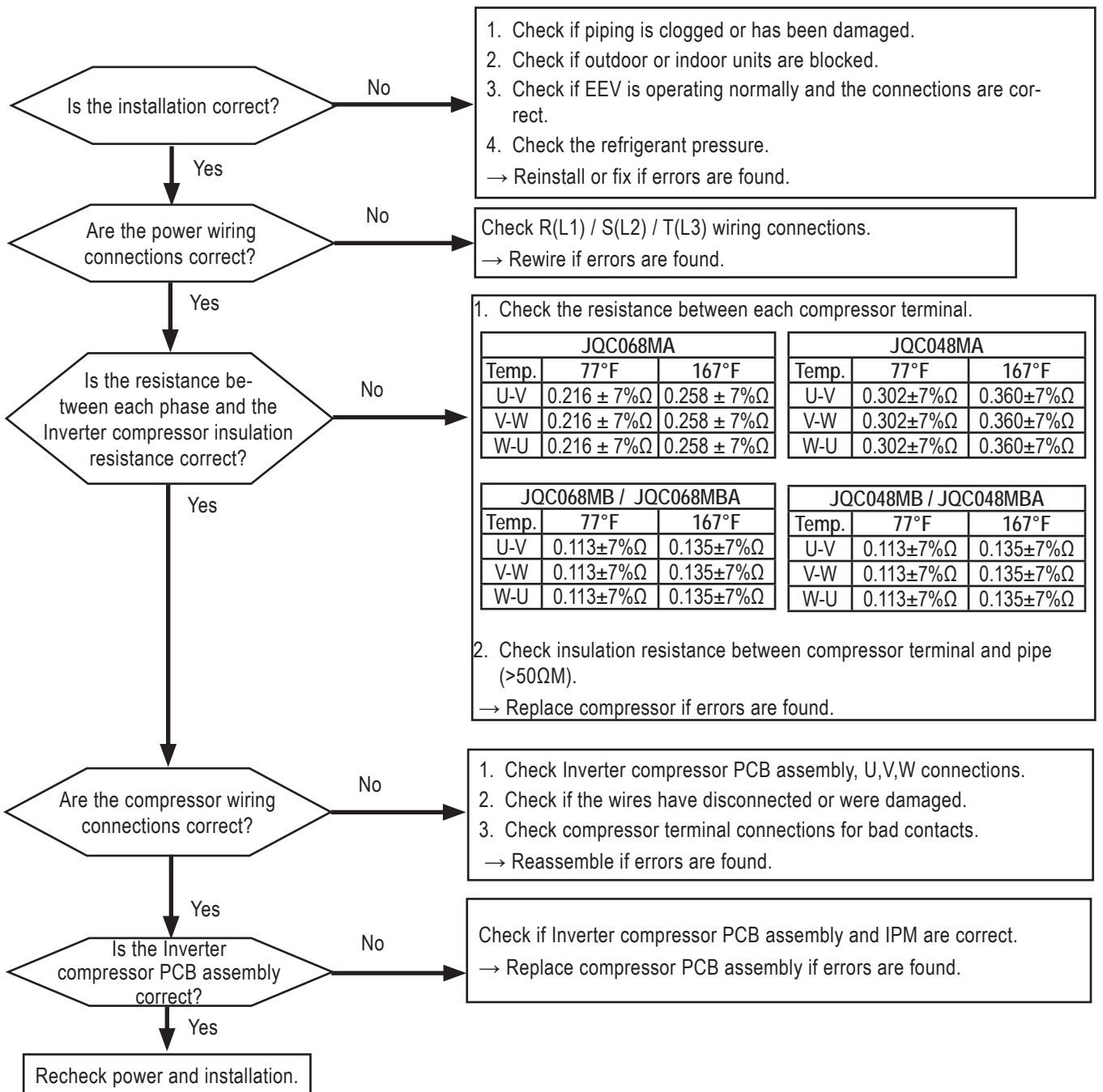

# ERROR CODES

Error No. 26, continued.

**⚠ WARNING** Please refer to the Safety Precautions on pages 4-7 for more detail to prevent injury or death regarding the operation and service troubleshooting of the Multi V product.

Measure resistance between compressor terminals.



Compressor wiring connections.

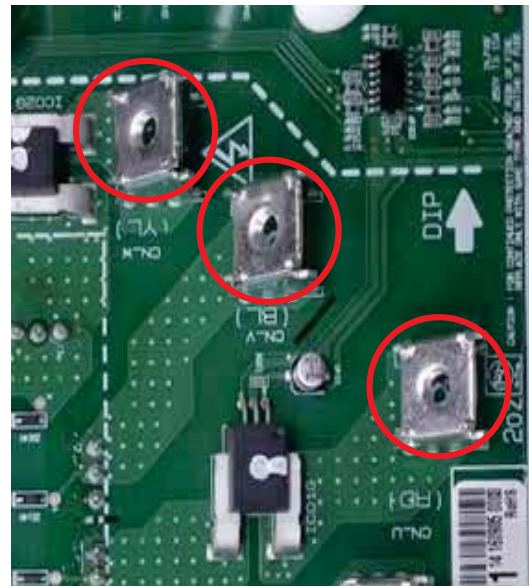

## Note:

Images here are representative of system components. Actual component appearance depends on model and system type.

Table 80: Error No. 26 Checkpoint Details.

Cause	Check	Checklist			App.
		Check Point	Normal	Abnormal	
Inverter PCB Damaged	Check Inverter PCB appearance	Appearance	Good	Damage	Inverter PCB B1 (Power Off)
	Measure 5V,15V line	5V, 15V Resistance	10kΩ↑	1kΩ↓ ~ 0Ω	
	IGBTM (Check IGBT)	P-U,V,W / N-U,V,W	0.38V ~ 0.7V	Non-normal	
	Inverter Drive Circuit (Check diode)	Diode	0.38V ~ 0.7V	Non-normal	

Figure 73: Two Compressor Additional Check Procedure (Same Capacity Inverter Only).

Standard Connection.

Example: Inverter 1, CH26 displayed.

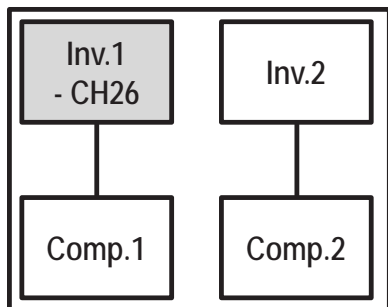

Cross Connections after Operation.

If Inverter 2 has CH26 displayed, then Comp. 1 is defective.

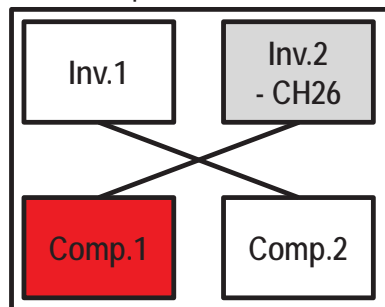

If Inverter 1 consistently displays CH26, then Inverter 1 is defective.

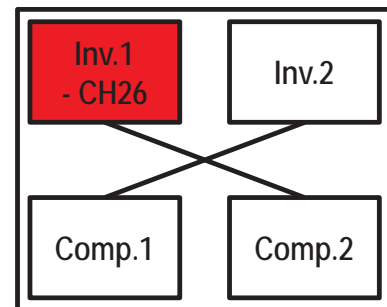

**WARNING** Please refer to the Safety Precautions on pages 4-7 for more detail to prevent injury or death regarding the operation and service troubleshooting of the Multi V product.

Error No.	Description	Details	Causes
29 Master: 291 Slave 1: 292 Slave 2: 293	Outdoor unit inverter compressor overcurrent error.	Inverter compressor input current is >30A.	<ol style="list-style-type: none"> <li>1. Overload operation (piping is clogged, indoor or outdoor unit is blocked, EEV is defective, refrigerant is overcharged).</li> <li>2. Compressor insulation and / or motor is / are damaged.</li> <li>3. Input voltage is low.</li> <li>4. Outdoor unit Inverter PCB assembly is damaged.</li> </ol>

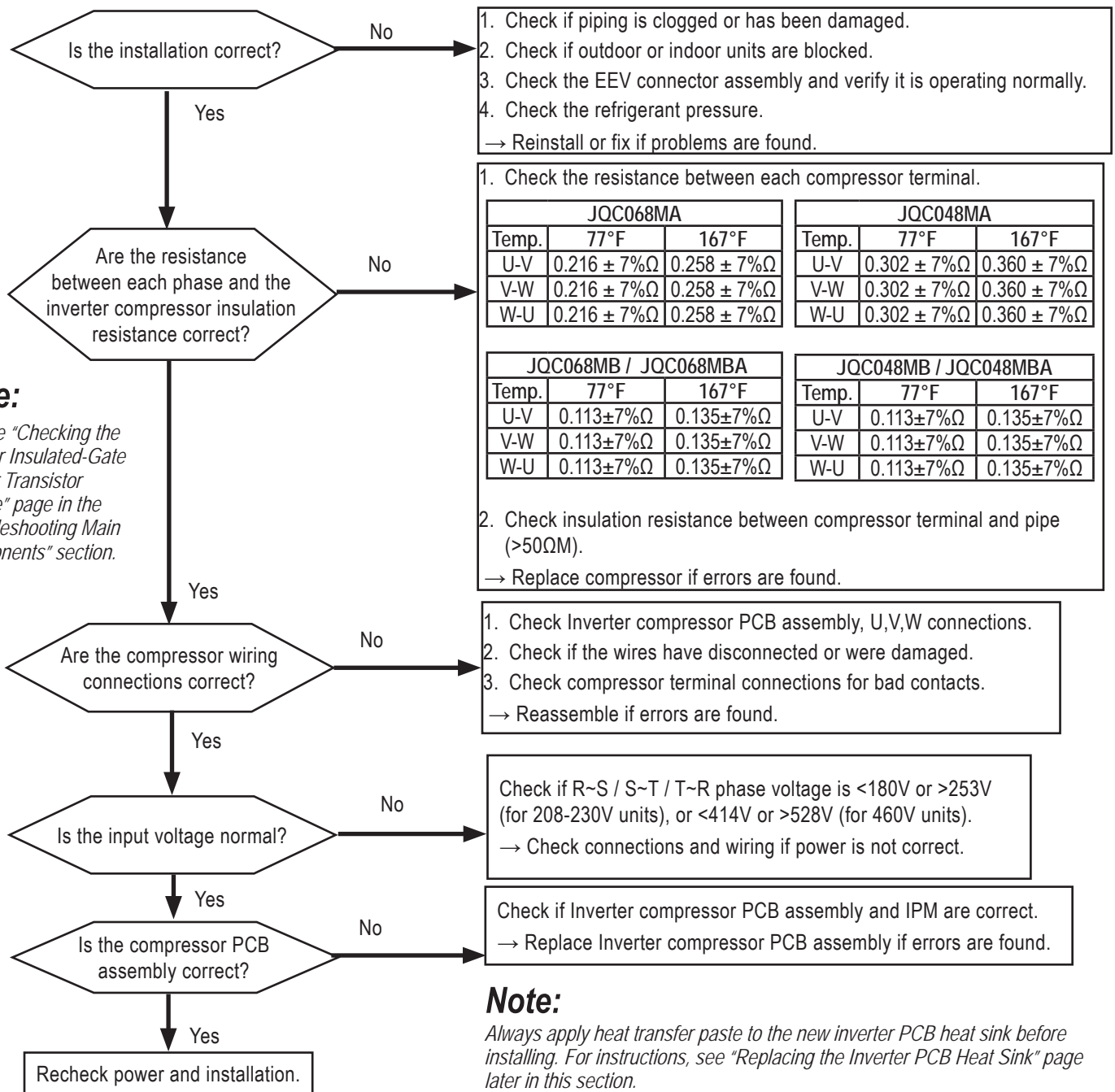

Error Codes

# ERROR CODES

Error No. 29, continued.

**⚠ WARNING** Please refer to the Safety Precautions on pages 4-7 for more detail to prevent injury or death regarding the operation and service troubleshooting of the Multi V product.

Measure resistance between compressor terminals.



Measure input voltage.



### Note:

Images here are representative of system components. Actual component appearance depends on model and system type.

Compressor wiring connections.

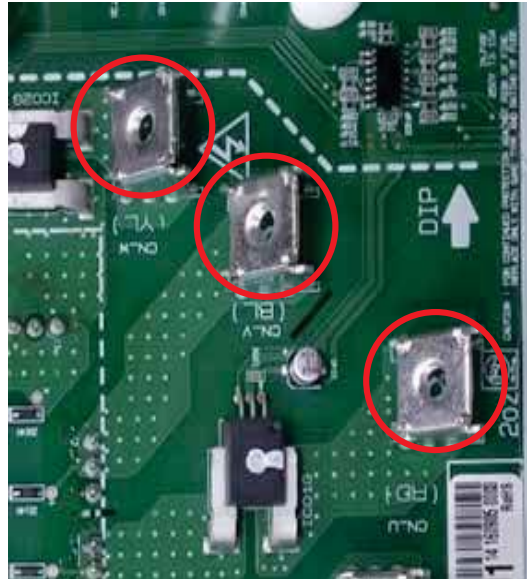

**⚠ WARNING** Please refer to the Safety Precautions on pages 4-7 for more detail to prevent injury or death regarding the operation and service troubleshooting of the Multi V product.

Error No.	Description	Details	Causes
32 Master: 321 Slave 1: 322 Slave 2: 323	Excessive increase in outdoor unit inverter compressor1 gas discharge temperature.	System / compressor shut off because of a high discharge temperature at the outdoor unit inverter compressor1.	1. System shutdown happens when discharge pipe temperature rises >115°C (239°F) for 10 seconds, or compressor dome temperature equals 105°C (221°F) for 10 seconds. 2. Defective inverter compressor discharge piping temperature sensor.
33 Master: 331 Slave 1: 332 Slave 2: 333	Excessive increase in outdoor unit inverter compressor2 gas discharge temperature.	System / compressor shut off because of a high discharge temperature at the outdoor unit inverter compressor2.	3. Refrigerant is leaking or there is under-charge. 4. Defective EEV. 5. Defective liquid spray valve.

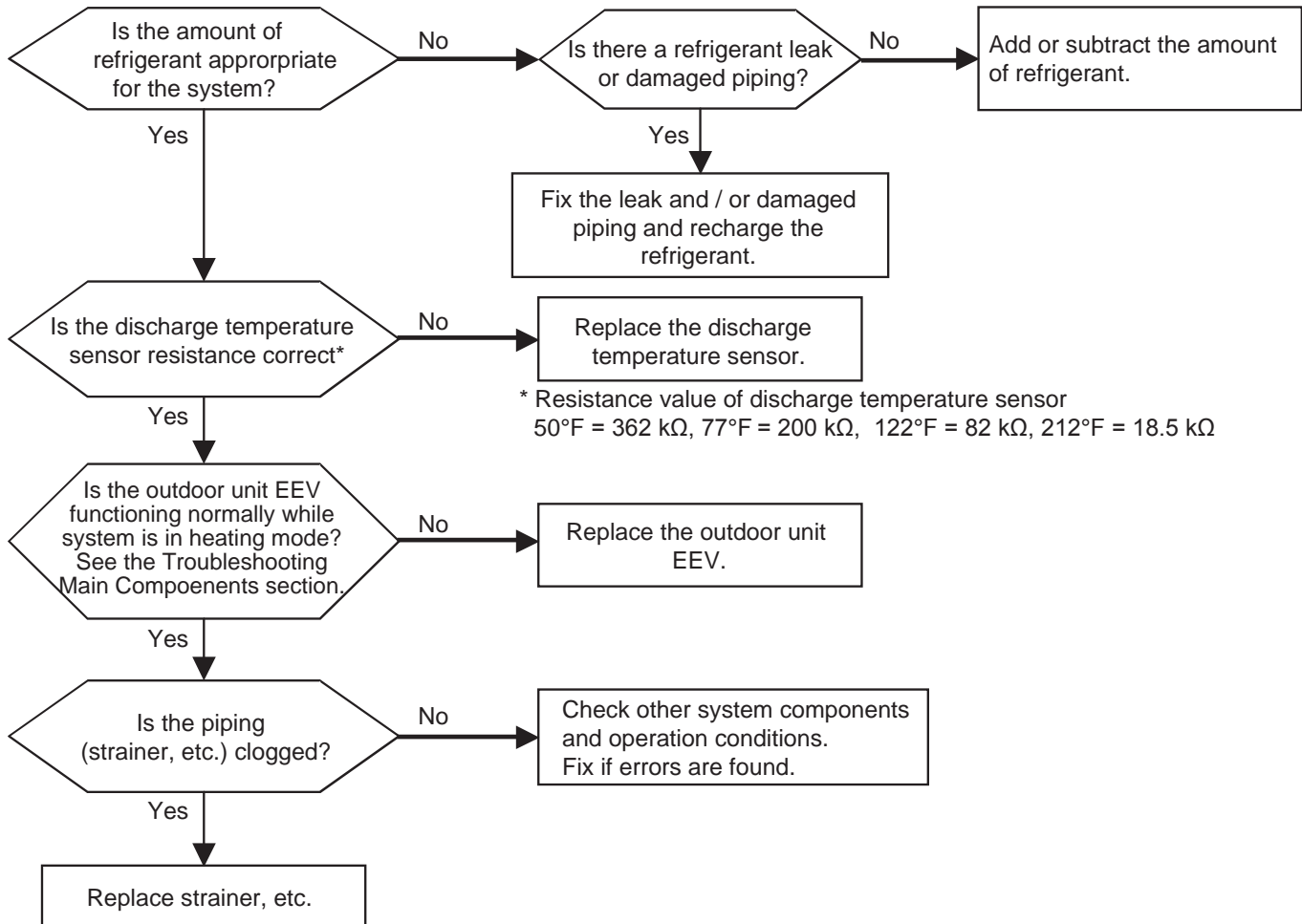

# ERROR CODES

## Error No. 34

**▲WARNING** Please refer to the Safety Precautions on pages 4-7 for more detail to prevent injury or death regarding the operation and service troubleshooting of the Multi V product.

Error No.	Description	Details	Causes
34 Master: 341 Slave 1: 342 Slave 2: 343	Outdoor unit compressor high pressure safety tripped.	System shut off because of an excessive increase in pressure at the outdoor unit that occurred ten (10) consecutive times.	<ol style="list-style-type: none"> <li>1. Shutdown due to if one compressor's high pressure is &gt;4,000 kPa (580 psi) for ten (10) seconds.</li> <li>2. Defective high pressure sensor.</li> <li>3. Defective indoor unit and / or outdoor unit fan.</li> <li>4. Refrigerant is overcharged.</li> <li>5. Refrigerant pipe is damaged.</li> <li>6. Defective indoor and / or outdoor unit EEV.</li> <li>7. Outdoor unit is blocked during cooling, or indoor unit filter is blocked during heating.</li> <li>8. Service valve is clogged.</li> <li>9. Defective outdoor unit PCB.</li> <li>10. Defective indoor unit pipe temperature.</li> <li>11. Defective indoor unit pipe temperature sensor.</li> <li>12. Defective hot gas valve.</li> </ol>

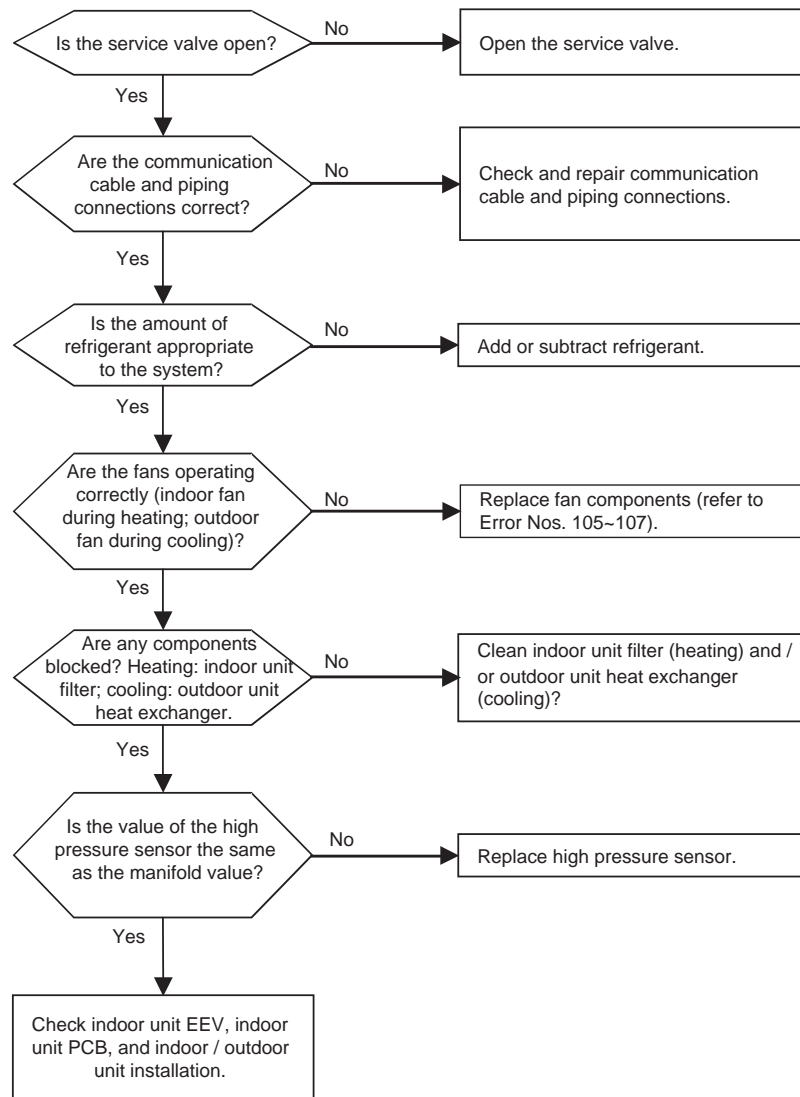

MULTI V 5 Outdoor Unit Service Manual

**WARNING** Please refer to the Safety Precautions on pages 4-7 for more detail to prevent injury or death regarding the operation and service troubleshooting of the Multi V product.

Error No.	Description	Details	Causes
35 Master: 351 Slave 1: 352 Slave 2: 353	Outdoor unit low side pressure transducer senses pressure below allowable limits.	System shut off because of an excessive decrease in pressure at the outdoor unit that occurred three consecutive times.	<ol style="list-style-type: none"> <li>1. Shut down occurs when the sum of all compressors inverter frequency &lt;30Hz = low &lt;110 kPa (15.95 psi) for 1 minute.</li> <li>2. When operating in cooling mode: Low side pressure &lt;400 kPa (58.02 psi) for 1 minute; High side pressure is &lt;2,200 kPa (319.08 psi). Check for refrigerant leaks (low refrigerant charge), or a defective indoor unit EEV.</li> <li>3. When operating in heating mode: Low side pressure &lt;230 kPa (33.36 psi) for 1 minute; High side pressure is &lt;1,800 kPa (261.07 psi). Check for refrigerant leaks (low refrigerant charge), or a defective outdoor unit EEV.</li> <li>4. Defective low pressure sensor.</li> <li>5. Defective indoor unit or outdoor unit fan.</li> <li>6. Refrigerant piping is damaged.</li> <li>7. The outdoor unit is blocked (dirty coil) in heating, and/or the indoor unit filter is blocked (plugged) in cooling.</li> <li>8. Service valve is clogged.</li> <li>9. Defective outdoor unit PCB.</li> <li>10. Defective indoor unit pipe temperature sensor.</li> </ol>

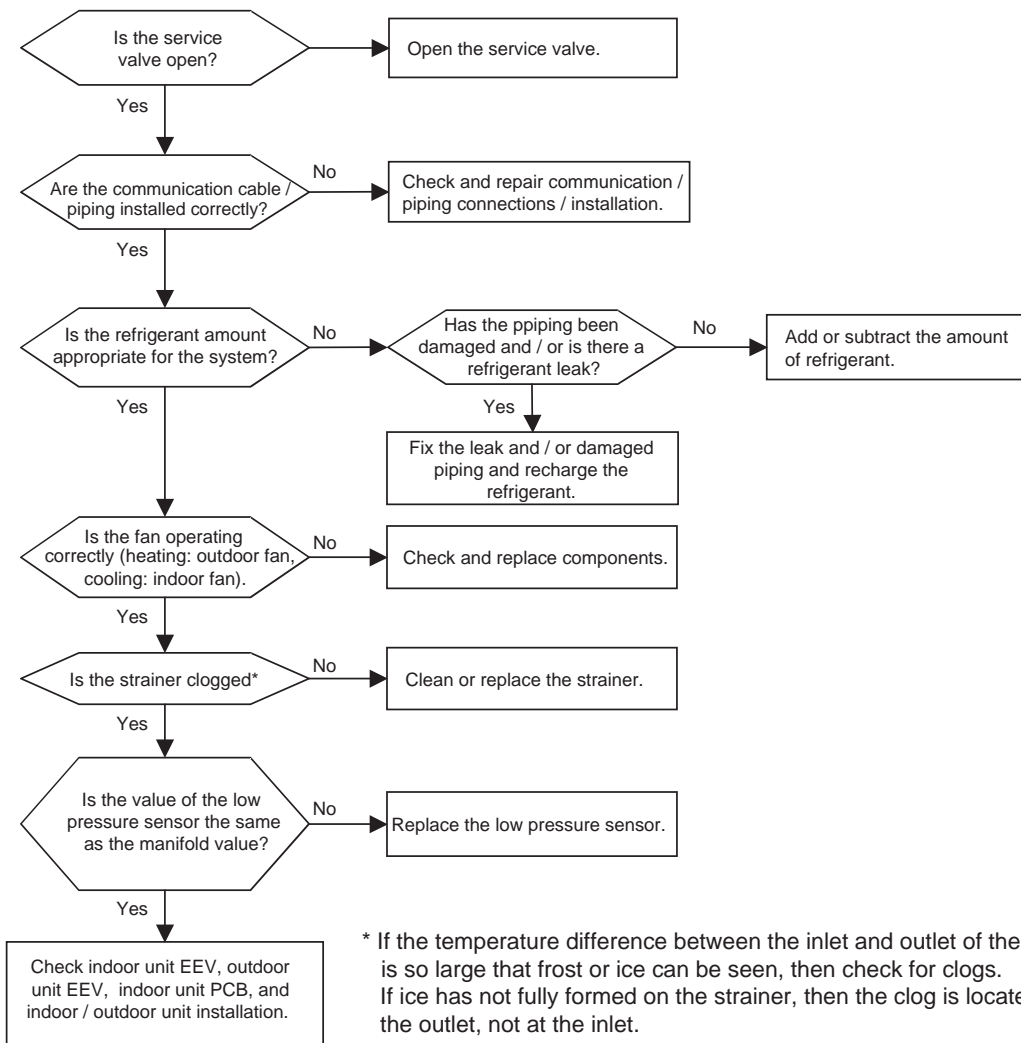

Error Codes

# ERROR CODES

## Error No. 36

**⚠ WARNING** Please refer to the Safety Precautions on pages 4-7 for more detail to prevent injury or death regarding the operation and service troubleshooting of the Multi V product.

Error No.	Description	Details	Causes
36 Master: 361 Slave 1: 362 Slave 2: 363	Outdoor unit inverter 1 or inverter 2 low compression ratio.	Outdoor unit is experiencing a problem developing compressor lift. Error is calling out low compression ratio (<1.6).	<ol style="list-style-type: none"> <li>1. During ongoing operation, if the compression ratio is &lt;1.6 for 2 to 5 minutes following a change in position of the reversing valve (either direction). If compression ratio is &lt;1.6, delay 5 minutes for condition to correct itself before raising the error.</li> <li>2. During low ambient cooling operation following an initial compressor start, if compression ratio is &lt;1.1 for 2 minutes, if compression ratio is &lt;1.3 for 3 minutes.</li> <li>3. Check bypass between high and low pressure side: EEV fully open, poor reversing valve operation, direct connection between low and high pressure vapor pipe (especially if reverse connection at Y-branch).</li> </ol>

**⚠ WARNING** Please refer to the Safety Precautions on pages 4-7 for more detail to prevent injury or death regarding the operation and service troubleshooting of the Multi V product.

Error No.	Description	Details	Causes
40 Master: 401 Slave 1: 402 Slave 2: 403	Outdoor unit inverter compressor current transducer (CT) sensor error.	Disconnection or short circuit of outdoor unit inverter compressor current detection (CT) sensor. MICOM input voltage is not within 2.5V ±0.3V at initial power up.	1. Input voltage is not correct (T-S). 2. Damaged DC power component (DC 5V). 3. Outdoor unit inverter PCB is damaged (CT sensor component).

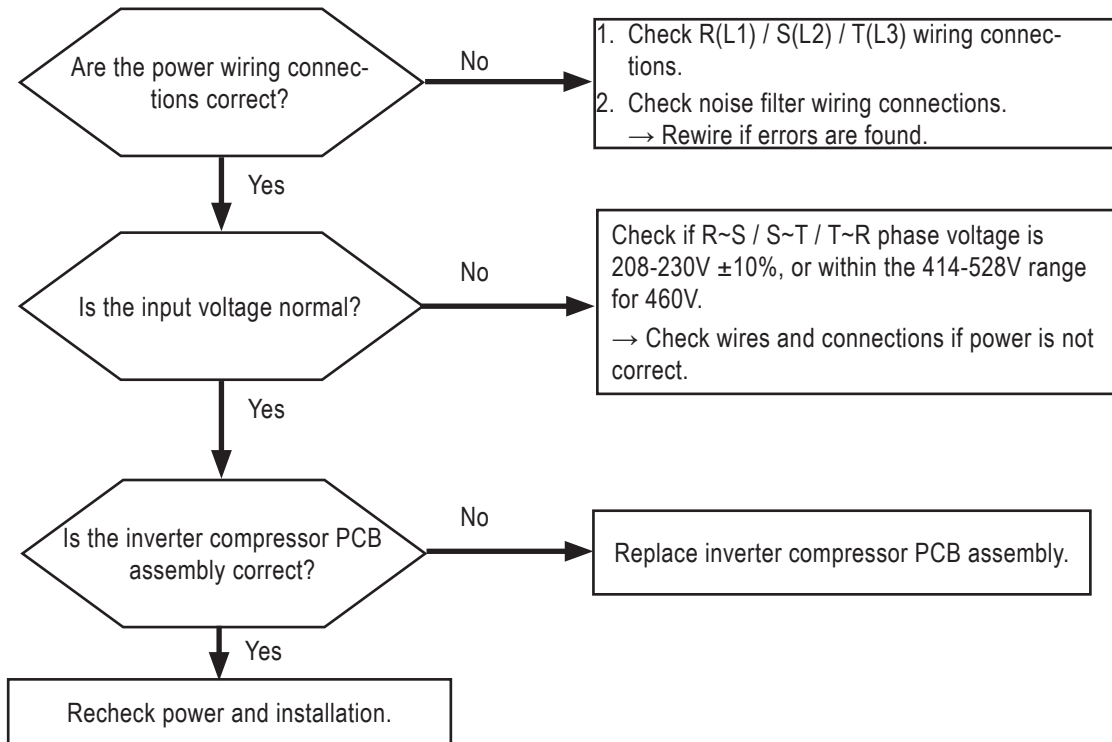

Measure input voltage.



Inverter compressor PCB assembly.



### Note:

Images here are representative of system components. Actual component appearance depends on model and system type.

# ERROR CODES

## Error Nos. 41 and 47

**▲WARNING** Please refer to the Safety Precautions on pages 4-7 for more detail to prevent injury or death regarding the operation and service troubleshooting of the Multi V product.

Error No.	Description	Details	Causes
41 (Inverter Compressor1) Master: 411 Slave 1: 412 Slave 2: 413	Outdoor unit inverter compressor discharge pipe temperature sensor error.	Disconnection or short circuit of outdoor unit compressor discharge temperature sensor. Error occurs within three (3) minutes of operation.	<ol style="list-style-type: none"> <li>1. Error can also occur if the system is operating in cooling at extremely low temperatures with no low ambient kit.</li> <li>2. Compressor discharge pipe temperature sensor (TH3) is not installed or connected properly.</li> <li>3. Defective compressor discharge pipe sensor (TH3) (opened or shorted).</li> <li>4. Defective outdoor unit PCB.</li> </ol>
47 (Inverter Compressor2) Master: 471 Slave 1: 472 Slave 2: 473		Error also occurs after three (3) minutes of compressor operation when discharge temperature sensor is removed (before compressor operation).	

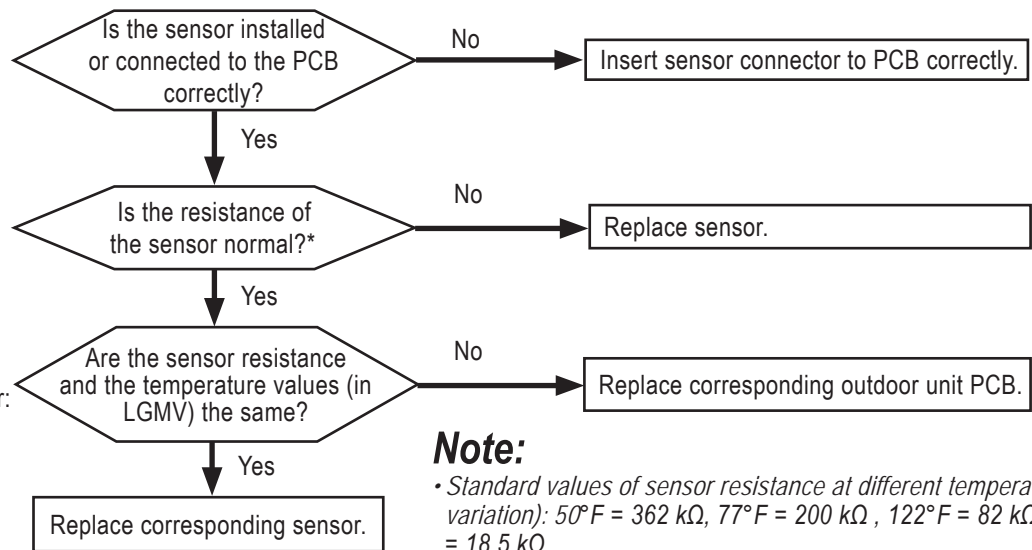

### Labels for Outdoor Unit Sensors:

- Outdoor Temperature Sensor: TH1
- Pipe Temperature Sensor: TH2
- Discharge Pipe (D-pipe) Temperature Sensor: TH3

\* Error is generated if resistance is >5 MΩ (open) and <2 kΩ (short).

### Note:

- Standard values of sensor resistance at different temperatures (5% variation): 50°F = 362 kΩ, 77°F = 200 kΩ, 122°F = 82 kΩ, 212°F = 18.5 kΩ.
- Other temperature sensor resistance values: 77°F = 10 kΩ ± 1%; 77°F = 5 kΩ ± 1%; 77°F = 200 kΩ ± 1%; 185°F = 1.07 kΩ ± 3.3%; 185°F = 535 kΩ ± 3.3%; 185°F = 28 kΩ ± 7.7%.

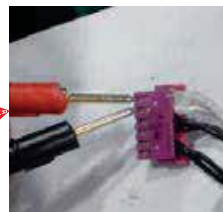
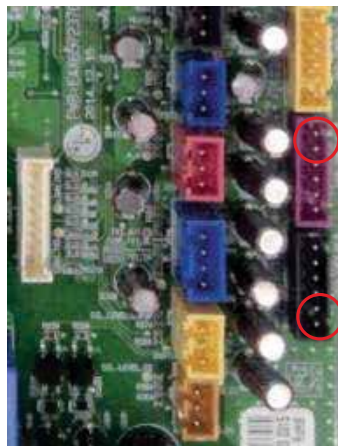

### Note:

Images here are representative of system components. Actual component appearance depends on model and system type.

Check the resistance of the Inverter compressor discharge temperature sensor.

**⚠ WARNING** Please refer to the Safety Precautions on pages 4-7 for more detail to prevent injury or death regarding the operation and service troubleshooting of the Multi V product.

Error No.	Description	Details	Causes
42 Master: 421 Slave 1: 422 Slave 2: 423	Outdoor unit low pressure sensor error.	Disconnection or short circuit of outdoor unit low pressure sensor.	<ol style="list-style-type: none"> <li>1. Check the connection on the outdoor unit PCB.</li> <li>2. Thermistor shorted or opened.</li> <li>3. Check for 12 V DC between 12 V and GND (red to black) for 5 V DC.</li> <li>4. Check the Signal to GND (white to black) and use correct chart from Troubleshooting section to compare with actual system pressure.</li> </ol>
43 Master: 431 Slave 1: 432 Slave 2: 433	Outdoor unit high pressure sensor error.	Disconnection or short circuit of outdoor unit high pressure sensor.	

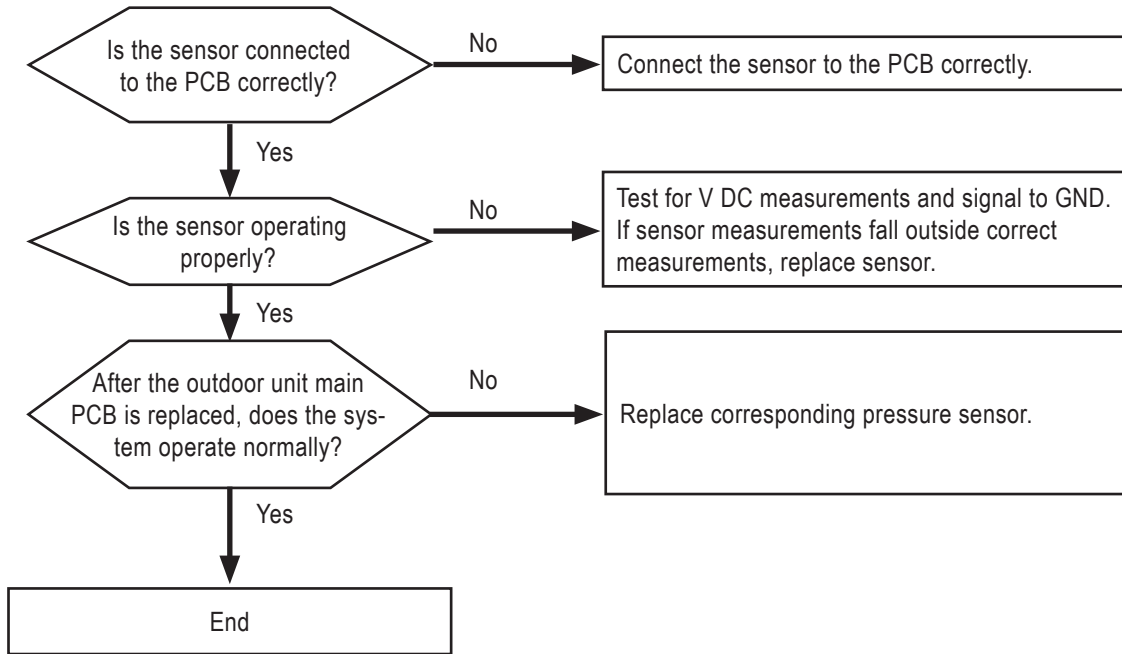

Pressure sensor connectors.

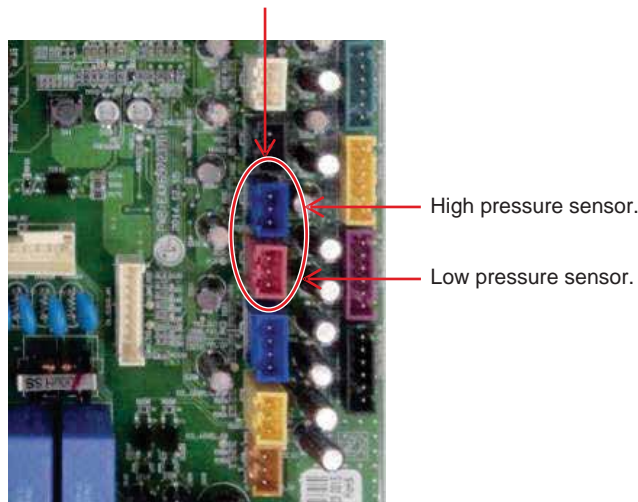

### Note:

Images here are representative of system components. Actual component appearance depends on model and system type.

# ERROR CODES

## Error Nos. 44, 45, 46, 49, 153, and 154

**▲WARNING** Please refer to the Safety Precautions on pages 4-7 for more detail to prevent injury or death regarding the operation and service troubleshooting of the Multi V product.

Error No.	Description	Details	Causes
44 Master: 441 Slave 1: 442 Slave 2: 443	Outdoor unit ambient air temperature sensor error.	Disconnection or short circuit of outdoor unit compressor discharge temperature sensor.	<ol style="list-style-type: none"> <li>1. Check the connection on the outdoor unit PCB.</li> <li>2. Thermistor shorted or opened.</li> </ol>
45 Master: 451 Slave 1: 452 Slave 2: 453	Outdoor unit heat exchanger pipe temperature sensor error.	Disconnection or short circuit of outdoor unit heat exchanger temperature sensor.	
46 Master: 471 Slave 1: 472 Slave 2: 473	Outdoor unit compressor suction piping temperature sensor error.	Disconnection or short circuit of outdoor unit compressor suction piping temperature sensor.	<ol style="list-style-type: none"> <li>1. Check the connection on the outdoor unit PCB.</li> <li>2. Thermistor shorted or opened.</li> <li>3. Check suction sensor in cooling mode; check hot gas sensor located near the heat exchanger in heating mode.</li> </ol>
49 Master: 491 Slave 1: 492 Slave 2: 493	Outdoor unit IGBT / IPM temperature sensor error.	Disconnection or short circuit of outdoor unit IGBT / IPM temperature sensor.	<ol style="list-style-type: none"> <li>1. Check the connection on the outdoor unit PCB.</li> <li>2. Thermistor shorted or opened.</li> </ol>

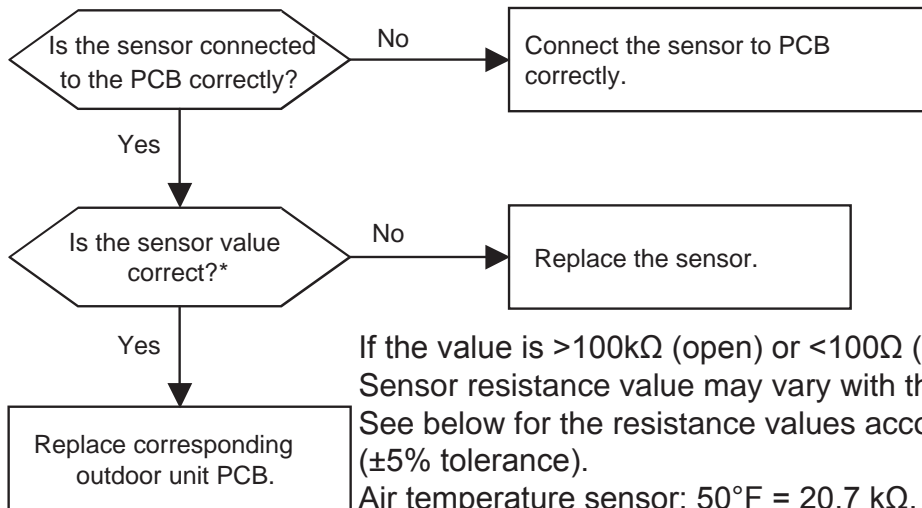

If the value is >100kΩ (open) or <100Ω (short), there is an error. Sensor resistance value may vary with the temperature.

See below for the resistance values according to temperature (±5% tolerance).

Air temperature sensor: 50°F = 20.7 kΩ, 77°F = 10 kΩ, 122°F = 3.4 kΩ.

Pipe temperature sensor: 50°F = 10 kΩ, 77°F = 5 kΩ, 122°F = 1.8 kΩ.

Error No.	Description	Details	Causes
153 Master 11: 531 Slave 1 12: 532 Slave 2 13: 533	Outdoor unit upper heat exchanger temperature sensor error.	Disconnection or short circuit of outdoor unit upper heat exchanger temperature sensor.	<ol style="list-style-type: none"> <li>1. Temperature sensor is not connected properly.</li> <li>2. Temperature sensor is defective (disconnected or short circuited).</li> <li>3. Defective outdoor unit main PCB.</li> </ol>
154 Master 11: 541 Slave 1 12: 542 Slave 2 13: 543	Outdoor unit lower heat exchanger temperature sensor error.	Disconnection or short circuit of outdoor unit lower heat exchanger temperature sensor.	

**⚠ WARNING** Please refer to the Safety Precautions on pages 4-7 for more detail to prevent injury or death regarding the operation and service troubleshooting of the Multi V product.

Error No.	Description	Details	Causes
50 Master: 501 Slave 1: 502 Slave 2: 503	Outdoor unit loss of phase.	One or more of R(L1), S(L2), T(L3) input power line connection(s) is / are missing for the outdoor unit.	<ol style="list-style-type: none"> <li>1. Input voltage is not correct R(L1), S(L2), T(L3).</li> <li>2. Power wiring connections may not be correct.</li> <li>3. Noise filter and / or connection error. Main PCB may be damaged.</li> <li>4. Inverter PCB input current sensor error.</li> </ol>

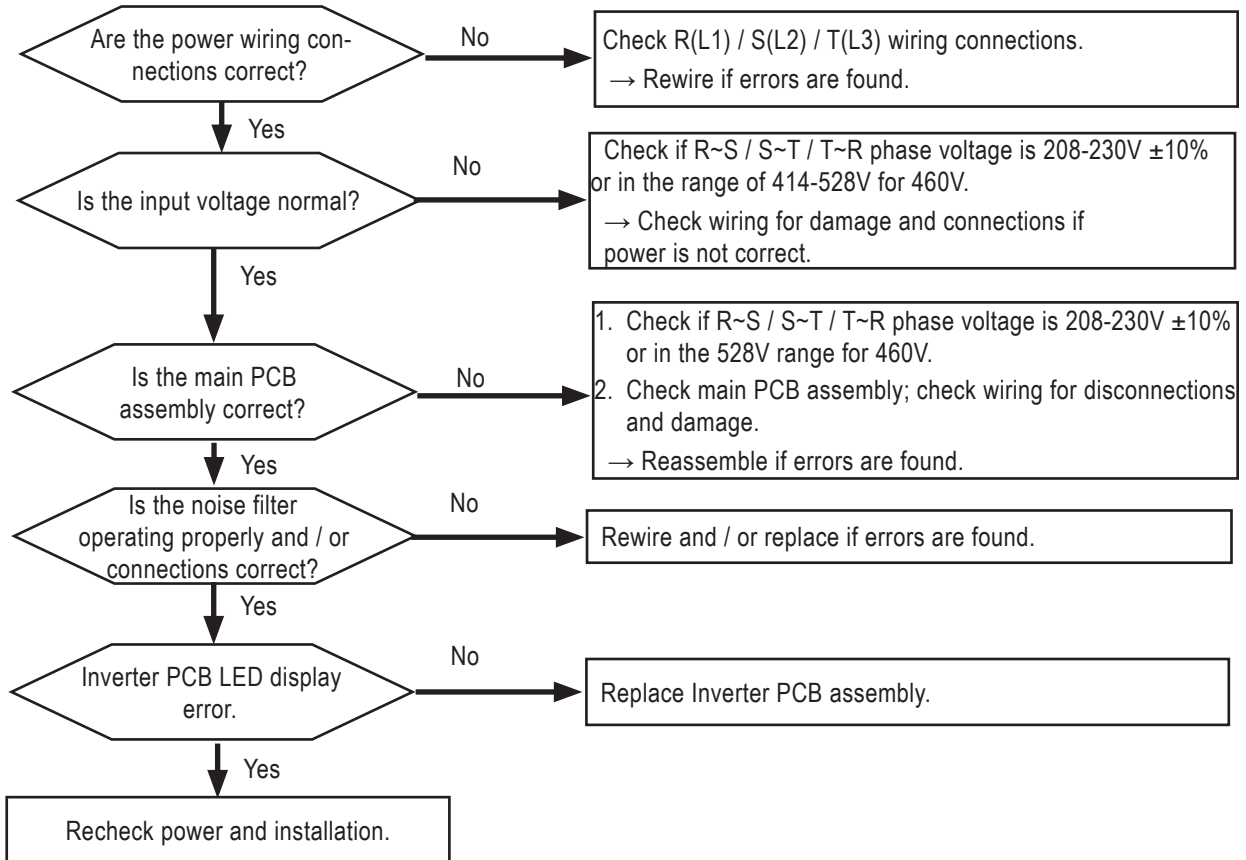

Error Codes

\* Measure input voltage.



\* Noise filter wiring.



\* Sign of a malfunction.



\* R-Phase terminal changed color.

**Note:**

Images here are representative of system components. Actual component appearance depends on model and system type.

# ERROR CODES

## Error No. 51(1)

**⚠ WARNING** Please refer to the Safety Precautions on pages 4-7 for more detail to prevent injury or death regarding the operation and service troubleshooting of the Multi V product.

Error No.	Description	Details	Causes
511 Master: 511	Combination ratio is out of range.	Value of total indoor unit capacity exceeds allowable outdoor unit capacity specifications.	<ol style="list-style-type: none"> <li>Total indoor unit capacity is more than 130% outdoor unit rated capacity.</li> <li>Wrong communication cable / piping connections.</li> <li>Control error of slave outdoor unit DIP switches.</li> <li>Defective slave unit PCB power supply.</li> <li>Defective outdoor unit PCB.</li> <li>Failed Master outdoor unit main PCB can also cause this error if it could not see the slave outdoor unit.</li> </ol>

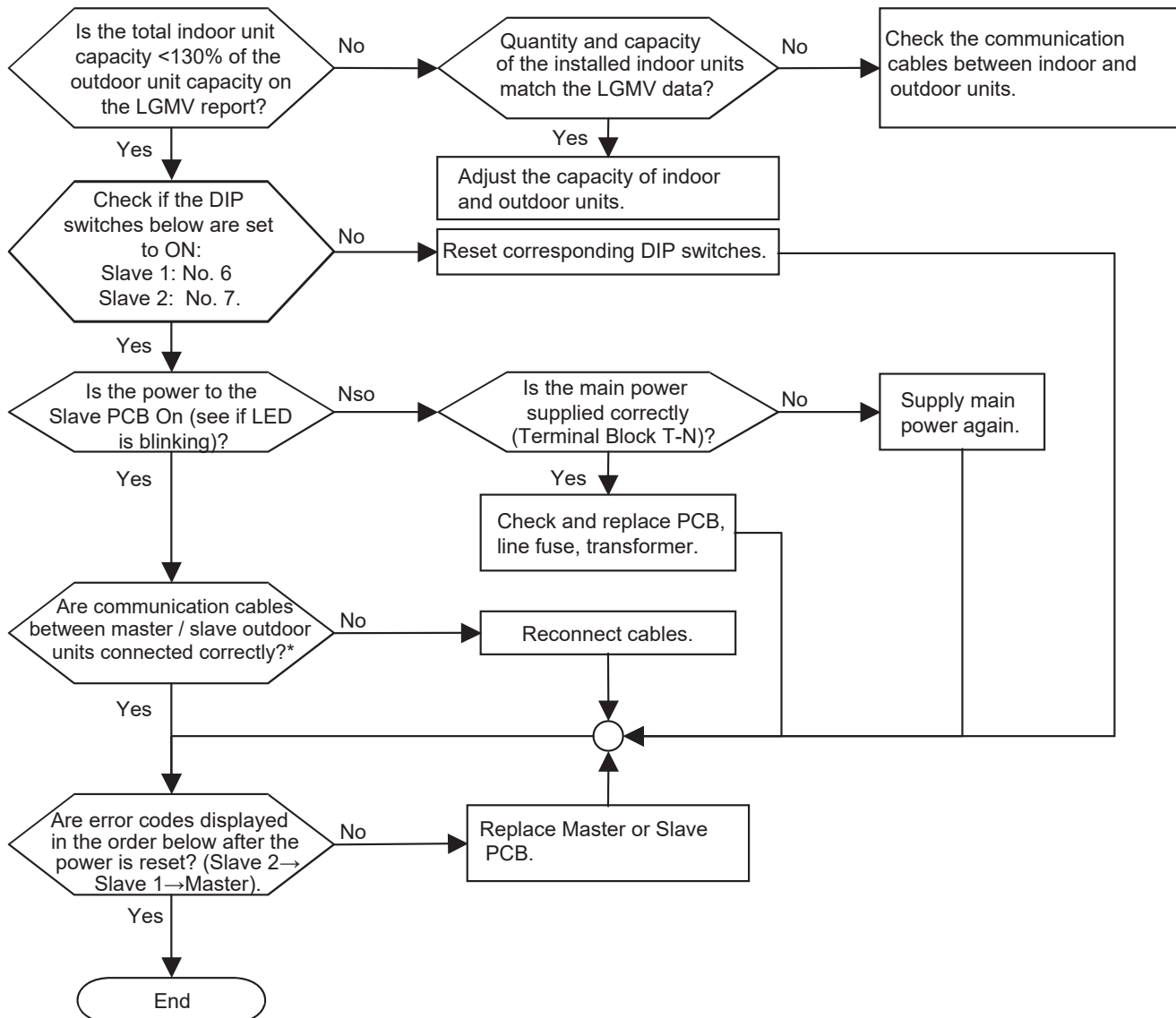

\* Check communication cables between outdoor units in the following order:  
PCB connections → terminal block → communication cables.

**Error No. 51(2) (for Heat Recovery Systems only)**

**⚠ WARNING** Please refer to the Safety Precautions on pages 4-7 for more detail to prevent injury or death regarding the operation and service troubleshooting of the Multi V product.

Error No.	Description	Details	Causes
512 Master: 512	Total indoor unit capacity exceeds allowable heat recovery unit branch capacity (Heat Recovery Systems only).	Value of total indoor unit capacity exceeds allowable heat recovery unit branch capacity specifications. After auto-pipe detection is complete, wait 5 minutes, then verify connected capacity. Total indoor unit capacity is >54,000 Btu/h for each heat recovery unit branch pipe.	<ol style="list-style-type: none"> <li>Heat recovery unit port addresses are all unique, then total indoor unit capacity is &gt;54,000 Btu/h per each heat recovery unit branch pipe.</li> <li>Total indoor units connected to each heat recovery unit branch pipe is &gt; eight (8).</li> <li>If 2 heat recovery unit port addresses are the same and the ports are twinned; &gt;108 Mbh total of multiple indoor units are connected.</li> <li>If 3 heat recovery unit port addresses are the same and the ports are all connected, &gt;162 Mbh total of multiple indoor units connected.</li> <li>If the total connected indoor unit nominal capacity exceeds 192 Mbh for a single heat recovery unit.</li> <li>Wrong transmission cable / piping connections.</li> <li>Outdoor unit and heat recovery unit PCB is defective.</li> </ol>

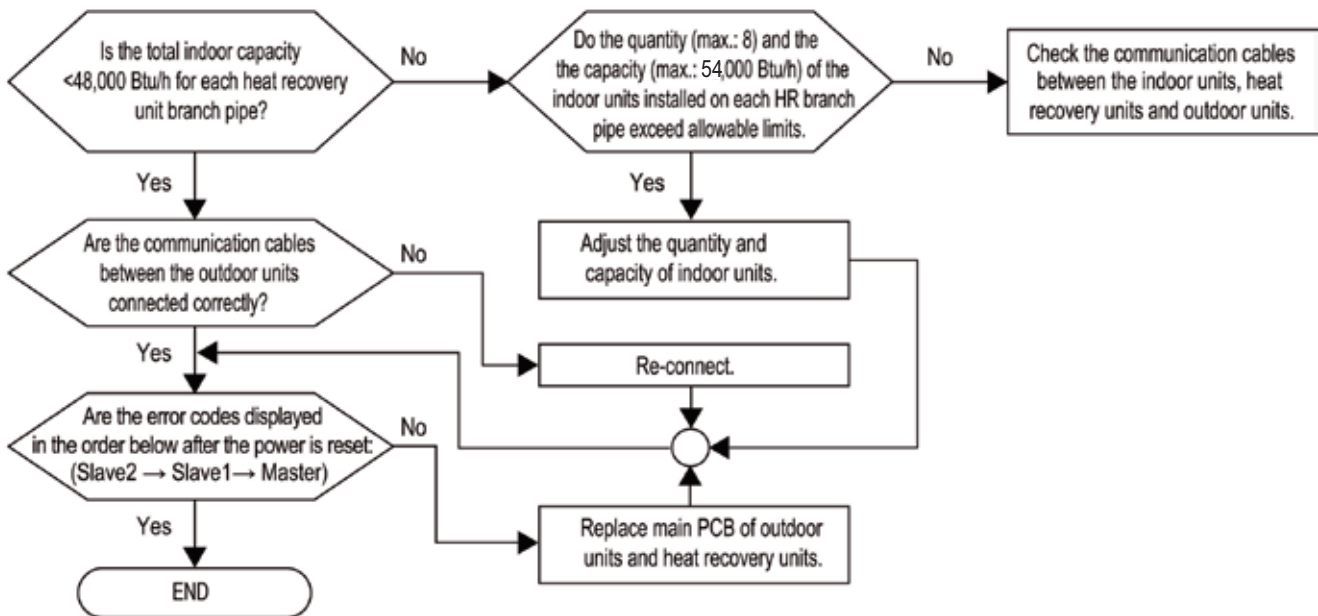

Error Codes

<sup>1</sup>To check the communication cables between the outdoor units, follow the order below:  
PCB connectors → terminal block → communication cables.

# ERROR CODES

## Error No. 52

**⚠ WARNING** Please refer to the Safety Precautions on pages 4-7 for more detail to prevent injury or death regarding the operation and service troubleshooting of the Multi V product.

Error No.	Description	Details	Causes
52 Master: 521 Slave 1: 522 Slave 2: 523	Communication error between outdoor unit inverter compressor PCB(s) and main PCB.	Outdoor unit main controller (PCB) cannot receive signal from inverter compressor controller (PCB[s]).	<ol style="list-style-type: none"> <li>1. Power wiring or communication cable is disconnected.</li> <li>2. Defective outdoor unit main fuse / noise filter.</li> <li>3. Defective outdoor unit main / inverter PCB(s).</li> </ol>

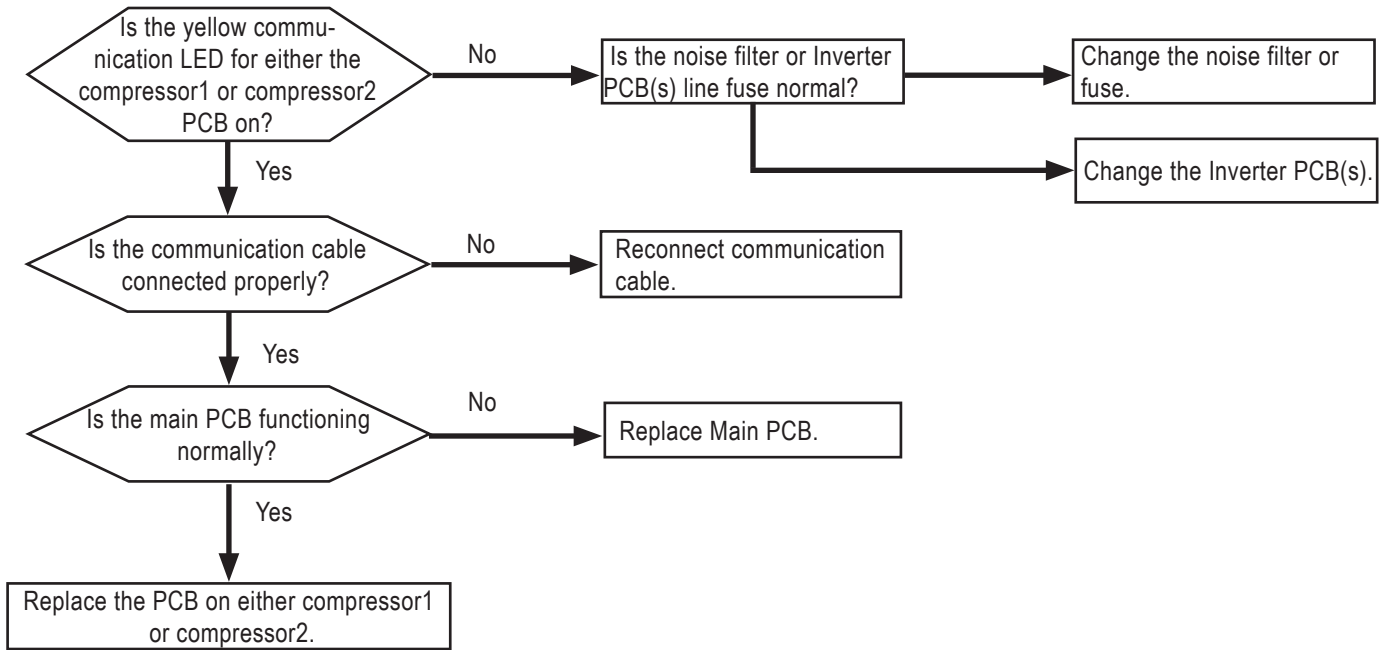

Checking the Main PCB and Inverter Compressor 1 / Inverter Compressor 2 PCB (If operating normally, the communication LED will blink)

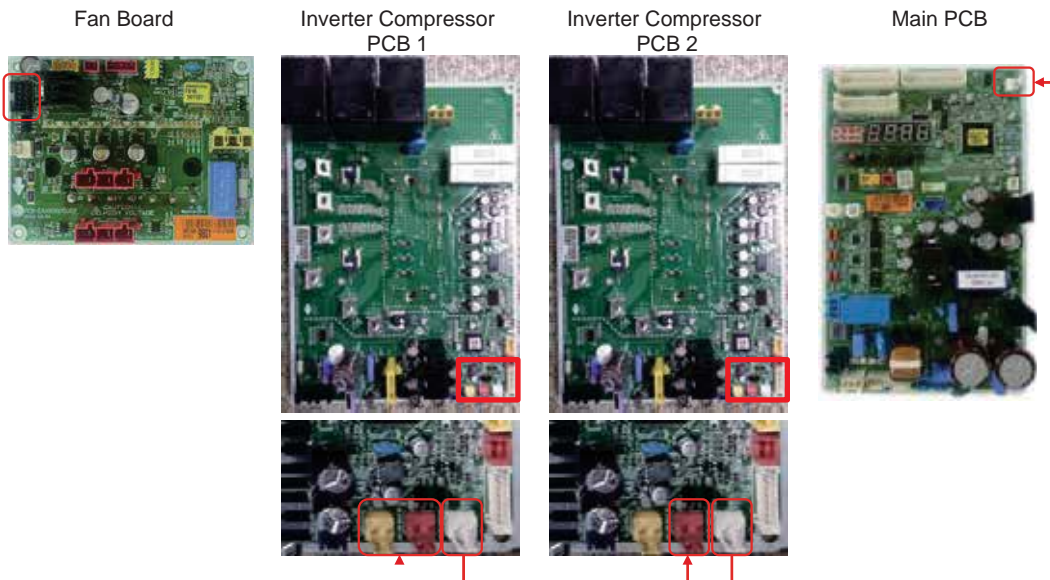

**Note:**  
Images here are representative of system components. Actual component appearance depends on model and system type.



**WARNING** Please refer to the Safety Precautions on pages 4-7 for more detail to prevent injury or death regarding the operation and service troubleshooting of the Multi V product.

Table 81: Error No. 52 Checkpoint Details.

Cause	Check	Checklist			Defective Parts	App.
		Check Point	Normal	Abnormal		
Inverter 5V, 15V Voltage Abnormal	Check 15V Voltage (Inverter connector)	Voltage	14.5V~15.5V	14V ↓	SMPS PCB	A2 (Power ON)
	Check 5V Voltage (Inverter connector)	Voltage	4.5V ~ 5.5V	4V ↓		
Inverter PCB Damaged	Check Inverter PCB Appearance	Appearance	Good	Damage	Inverter PCB	B1 (Power Off)
	Measure 5V,15V line	5V, 15V Resistance	10kΩ↑	1kΩ↓ ~ 0Ω		
	IGBTM (Check IGBT)	P-U,V,W / N-U,V,W	0.38V ~ 0.7V	Non-normal		
	Inverter Drive circuit (Check diode)	Diode	0.38V ~ 0.7V	Non-normal		
Fan PCB Damaged	Check Fan PCB Appearance	Appearance	Good	Damage	Fan PCB	B3 (Power Off)
	Check Fuse	Fuse	Short	Open		
	Measure 5V,15V line	5V, 15V Resistance	10kΩ↑	1kΩ↓ ~ 0Ω		
	IPM (Check IGBT)	P-U,V,W / N-U,V,W	0.38V ~ 0.7V	Non-normal		
	Inverter Drive circuit (Check diode)	Diode	0.38V ~ 0.7V	Non-normal		

# ERROR CODES

## Error No. 53

**▲WARNING** Please refer to the Safety Precautions on pages 4-7 for more detail to prevent injury or death regarding the operation and service troubleshooting of the Multi V product.

Error No.	Description	Details	Causes
53 Master: 531 Slave 1: 532 Slave 2: 533	Communication error between outdoor unit main PCB and indoor unit(s) PCB.	Outdoor unit main PCB cannot receive the signal from the indoor unit.	<ol style="list-style-type: none"> <li>1. Communication cables are not connected between external PCB and indoor PCB.</li> <li>2. Communications cables are disconnected or have short circuited between the main PCB and external PCB.</li> <li>3. Communication cables are disconnected or have short circuited between the main PCB and communication PCB.</li> <li>4. Communication cables are disconnected or have short circuited (communication cable connection error.)</li> <li>5. Power to the indoor PCB is off.</li> <li>6. Defective outdoor unit main PCB, communication PCB, and / or indoor unit PCB.</li> <li>7. Outdoor unit main PCB / indoor unit PCB is defective or damaged.</li> </ol>

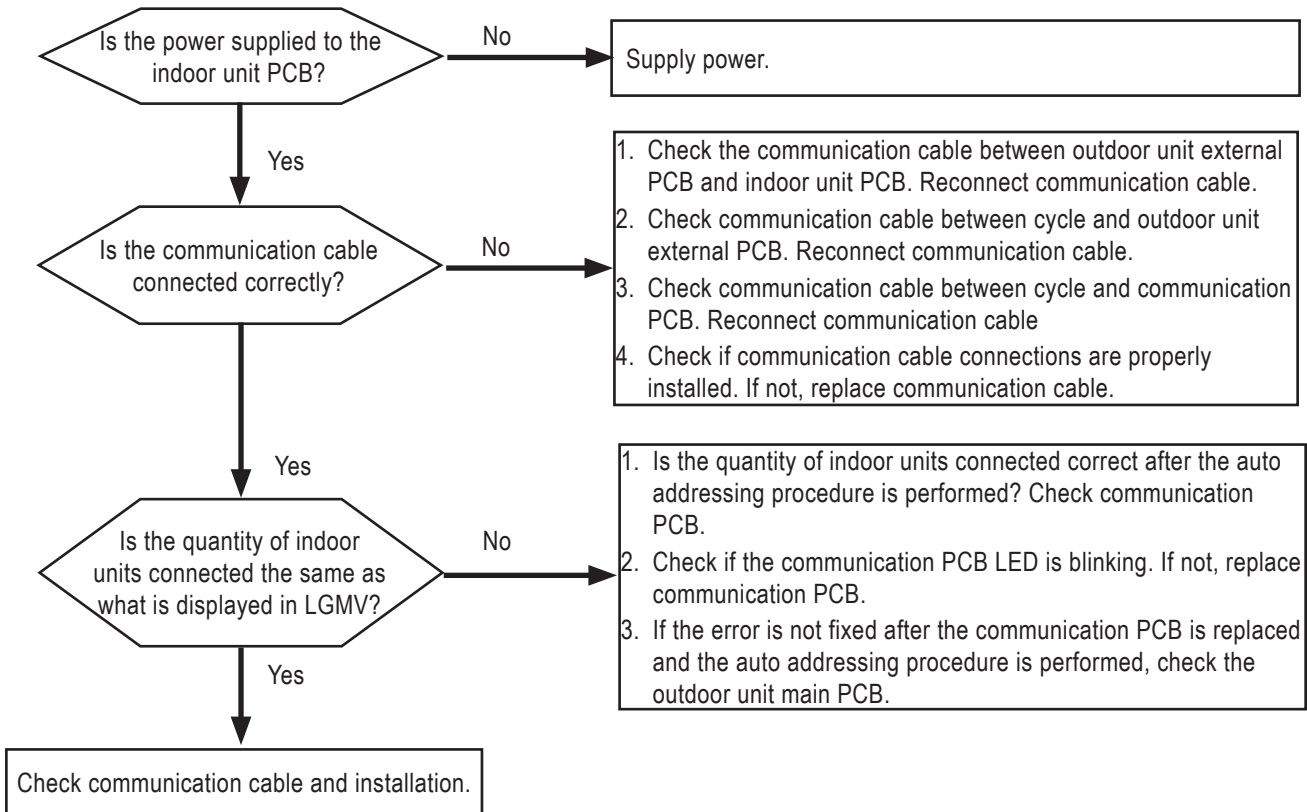

MULTI V 5 Outdoor Unit Service Manual

**⚠ WARNING** Please refer to the Safety Precautions on pages 4-7 for more detail to prevent injury or death regarding the operation and service troubleshooting of the Multi V product.

Error No. 53 indicates there is a communication error between the outdoor unit and indoor unit(s). See LGMV to help determine which indoor unit or units are not communicating with the outdoor unit.

- Does LGMV display the correct number of indoor units? If LGMV DOES NOT display the correct number of indoor units, find the missing indoor unit or units and troubleshoot.
- If LGMV DOES displays the correct number of indoor units, but the outdoor unit still shows CH53, check the communication count line on LGMV. Find the indoor unit that does not have a communication count increase—that indicates the indoor unit which is not communicating. The indoor unit may have:
  1. Wrong communication cable or power wiring connection(s).
  2. A PCB malfunction.
  3. Duplicate address numbers for indoor units (Error No. 53 will appear at the indoor unit).

LGMV Communication Line Example

IDU Gr. 1		More HR Info						More IdU Info	
	Comm.	CEN	error	humidity	H/L	TGT	TGT2		
IDU1	38	6	0	0	0	0	0		
IDU2	39	2	0	0	0	0	0		
IDU3	38	8	0	0	0	0	0		
IDU4	37	1	0	0	0	0	0		
IDU5	37	0	0	0	0	0	0		
IDU6	37	5	0	0	0	0	0		
IDU7	38	7	0	0	0	0	0		
IDU8	38	4	0	0	0	0	0		

External PCB



Wiring Error.



Main PCB



Indoor Unit Communication PCB



### Note:

- If communication in general is not functioning properly, then the auto addressing procedure has not been performed yet or has not been performed properly.
- Auto addressing must be performed after an indoor unit PCB has been replaced. Also, if a central controller is installed, the central controller address must be input.
- In addition to the information presented here, see also the troubleshooting procedure for Error No. 05.

### Note:

Images here are representative of system components. Actual component appearance depends on model and system type.

# ERROR CODES

## Error No. 57

**⚠ WARNING** Please refer to the Safety Precautions on pages 4-7 for more detail to prevent injury or death regarding the operation and service troubleshooting of the Multi V product.

Error No.	Description	Details	Causes
57 Master: 571 Slave 1: 572 Slave 2: 573	Communication error between outdoor unit main PCB and inverter PCB.	Outdoor unit inverter PCB is not receiving signal from main PCB.	<ol style="list-style-type: none"> <li>1. Bad connection between main and inverter PCBs.</li> <li>2. Communication wire noise effect.</li> <li>3. The outdoor unit main PCB is damaged.</li> <li>4. The outdoor unit inverter PCB is damaged.</li> </ol>

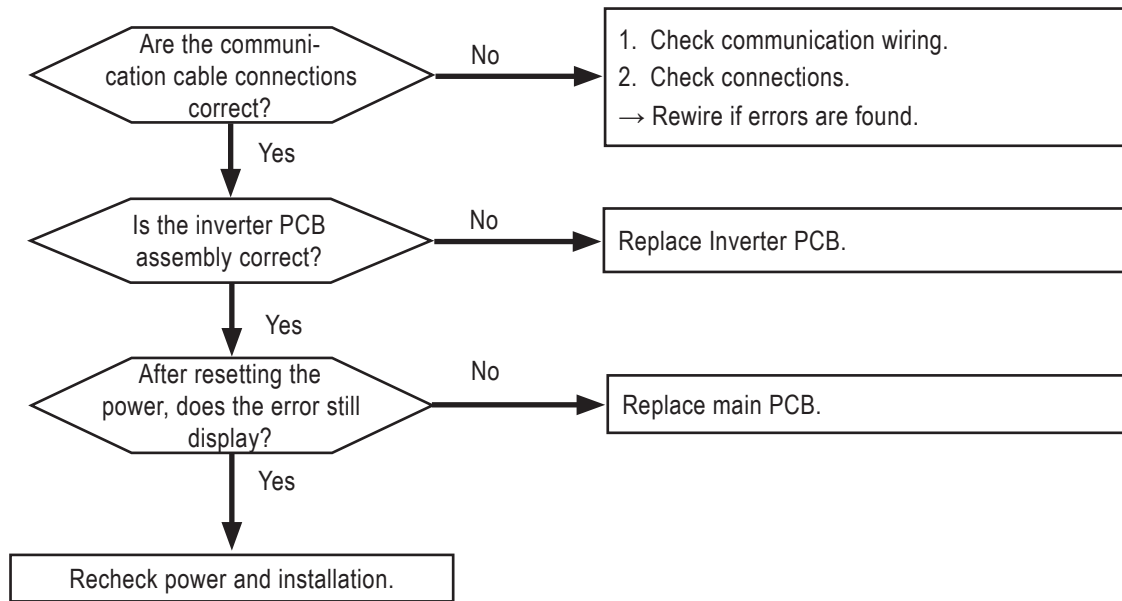

Fan Board

Inverter Compressor PCB 1

Inverter Compressor PCB 2

Main PCB

Communication LED

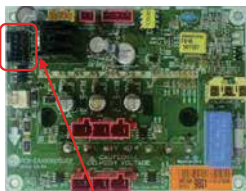

Communication LED



Communication LED



Communication LED

### Note:

Images here are representative of system components. Actual component appearance depends on model and system type.

**⚠ WARNING** Please refer to the Safety Precautions on pages 4-7 for more detail to prevent injury or death regarding the operation and service troubleshooting of the Multi V product.

Error No.	Description	Details	Causes
60 Master: 601 Slave 1: 602 Slave 2: 603	Outdoor unit inverter PCB EEPROM error.	EEPROM access and "Check SUM" errors.	<ol style="list-style-type: none"> <li>EEPROM contact is defective, or the contact is not inserted correctly.</li> <li>Different EEPROM version.</li> <li>Outdoor unit inverter PCB assembly is damaged.</li> </ol>

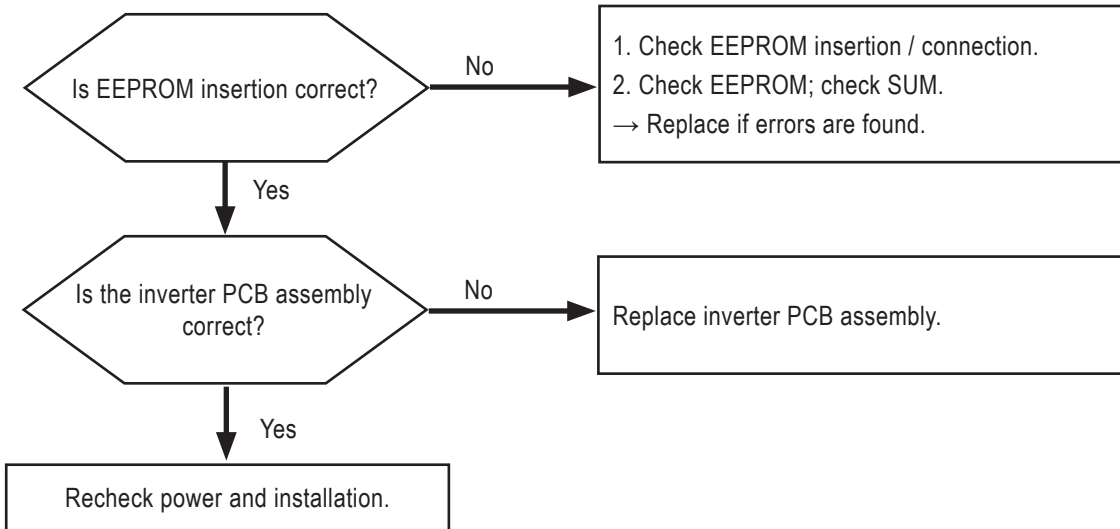

Inverter EEPROM installation.

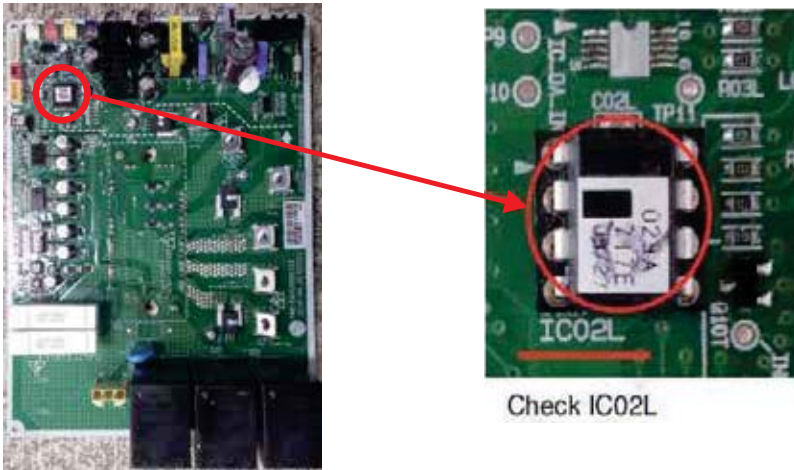

**⚠ WARNING**

Replace EEPROM only after the power is turned off. There is a risk of electric shock that could cause physical injury or death.

**Note:**

Images here are representative of system components. Actual component appearance depends on model and system type.

Correct Inverter EEPROM installation direction.

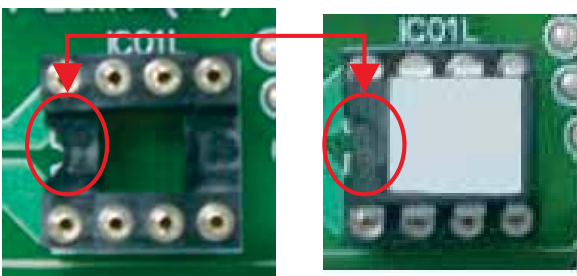

# ERROR CODES

## Error No. 62

**▲WARNING** Please refer to the Safety Precautions on pages 4-7 for more detail to prevent injury or death regarding the operation and service troubleshooting of the Multi V product.

Error No.	Description	Details	Causes
62 Master: 621 Slave 1: 622 Slave 2: 623	High temperature at the outdoor unit inverter PCB heat sink.	Heatsink temperature is >257°F.	<ol style="list-style-type: none"> <li>1. Inverter PCB IGBT / IPM connection is not correct.</li> <li>2. Outdoor unit fan motor operation is malfunctioning.</li> <li>3. Outdoor unit inverter PCB assembly is defective.</li> <li>4. Overload operation (pipe is clogged, fan is blocked, EEV is defective, overcharge in refrigerant).</li> </ol>

MULTI V 5 Outdoor Unit Service Manual

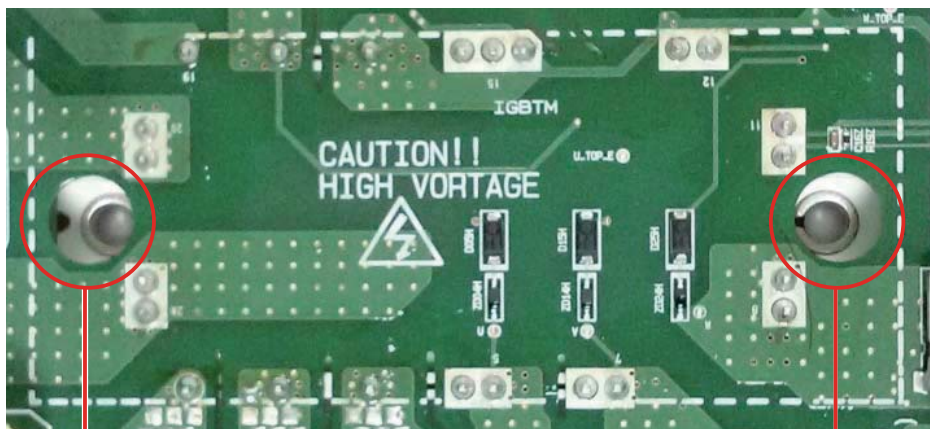
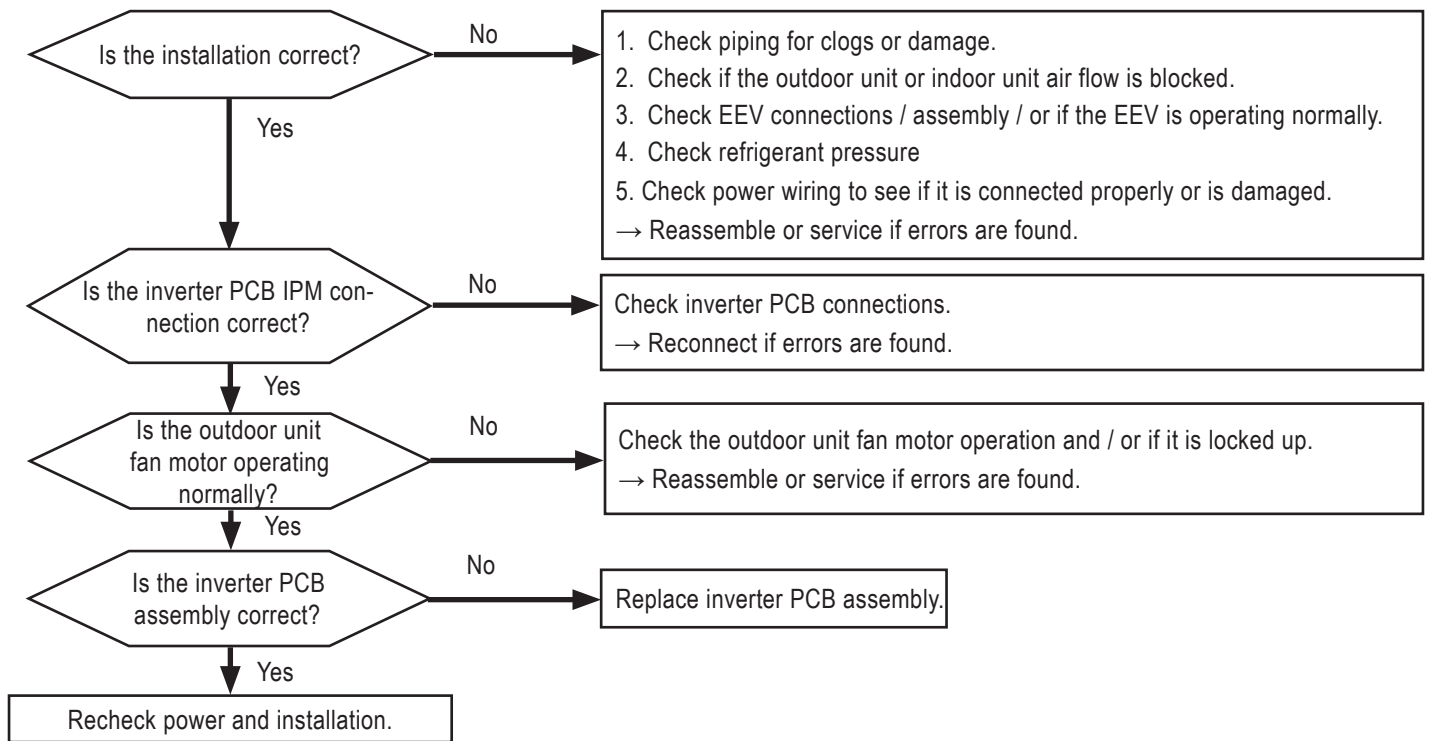

Check Inverter PCB Connection Installation

**Note:**

Images here are representative of system components. Actual component appearance depends on model and system type.

**Note:**

Always apply heat transfer paste to the new inverter PCB heat sink before installing. For instructions, see "Replacing the Inverter PCB Heat Sink" page later in this section.

**⚠ WARNING** Please refer to the Safety Precautions on pages 4-7 for more detail to prevent injury or death regarding the operation and service troubleshooting of the Multi V product.

Error No.	Description	Details	Causes
65 Master: 651 Slave 1: 652 Slave 2: 653	Outdoor unit liquid pipe (condenser) temperature sensor error.	Abnormal sensor resistance value.	<ol style="list-style-type: none"> <li>1. Defective temperature sensor connection.</li> <li>2. Defective temperature sensor (sensor has (opened or shorted).</li> <li>3. Defective outdoor unit PCB.</li> </ol>

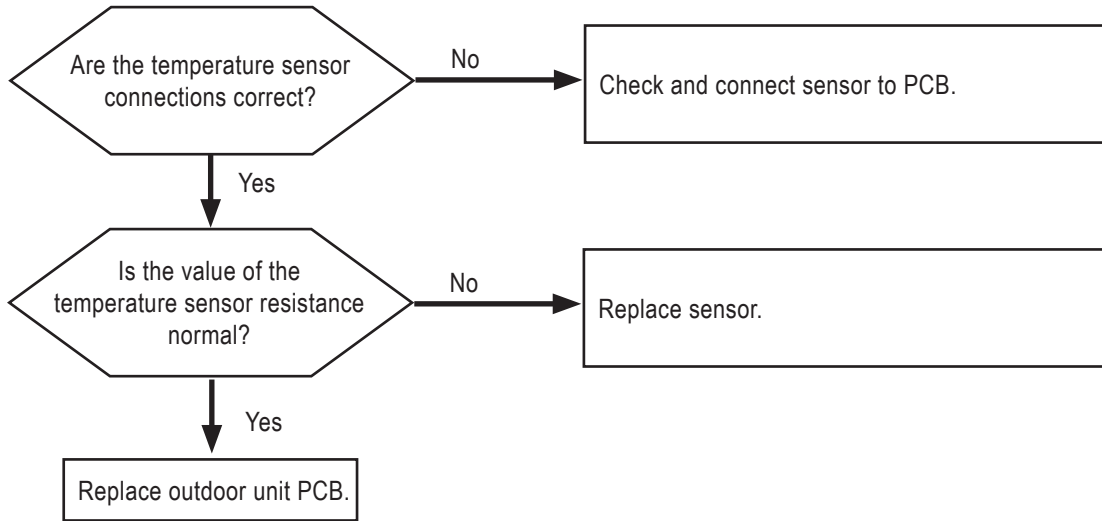

- If the value is >100kΩ (open) or <100Ω (short), there is an error.
- Sensor resistance value will vary with the temperature. See below for the resistance values according to temperature (±5% tolerance).
- Air temperature sensor: 50°F = 20.7 kΩ, 77°F = 10 kΩ, 122°F = 3.4 kΩ.
- Pipe temperature sensor: 50°F = 10 kΩ, 77°F = 5 kΩ, 122°F = 1.8 kΩ.

**Note:**

See also Error Code No. 113, Outdoor Unit Liquid Pipe (Condenser) Temperature Sensor Error.

# ERROR CODES

## Error No. 67

**⚠ WARNING** Please refer to the Safety Precautions on pages 4-7 for more detail to prevent injury or death regarding the operation and service troubleshooting of the Multi V product.

Error No.	Description	Details	Causes
67 Master: 671 Slave 1: 672 Slave 2: 673	Outdoor unit fan has locked up.	RPM is $\leq 10$ RPM for five (5) seconds when the outdoor unit fan starts, or $\leq 40$ RPM after fan starts.	<ol style="list-style-type: none"> <li>1. Fan motor is defective or assembly is not correct.</li> <li>2. Fan motor connection is wrong (U,V,W output).</li> <li>3. Rotation has reversed after RPM target is achieved.</li> <li>4. Fan PCB assembly is defective.</li> <li>5. Fan air flow is blocked by heavy snowfall.</li> </ol>

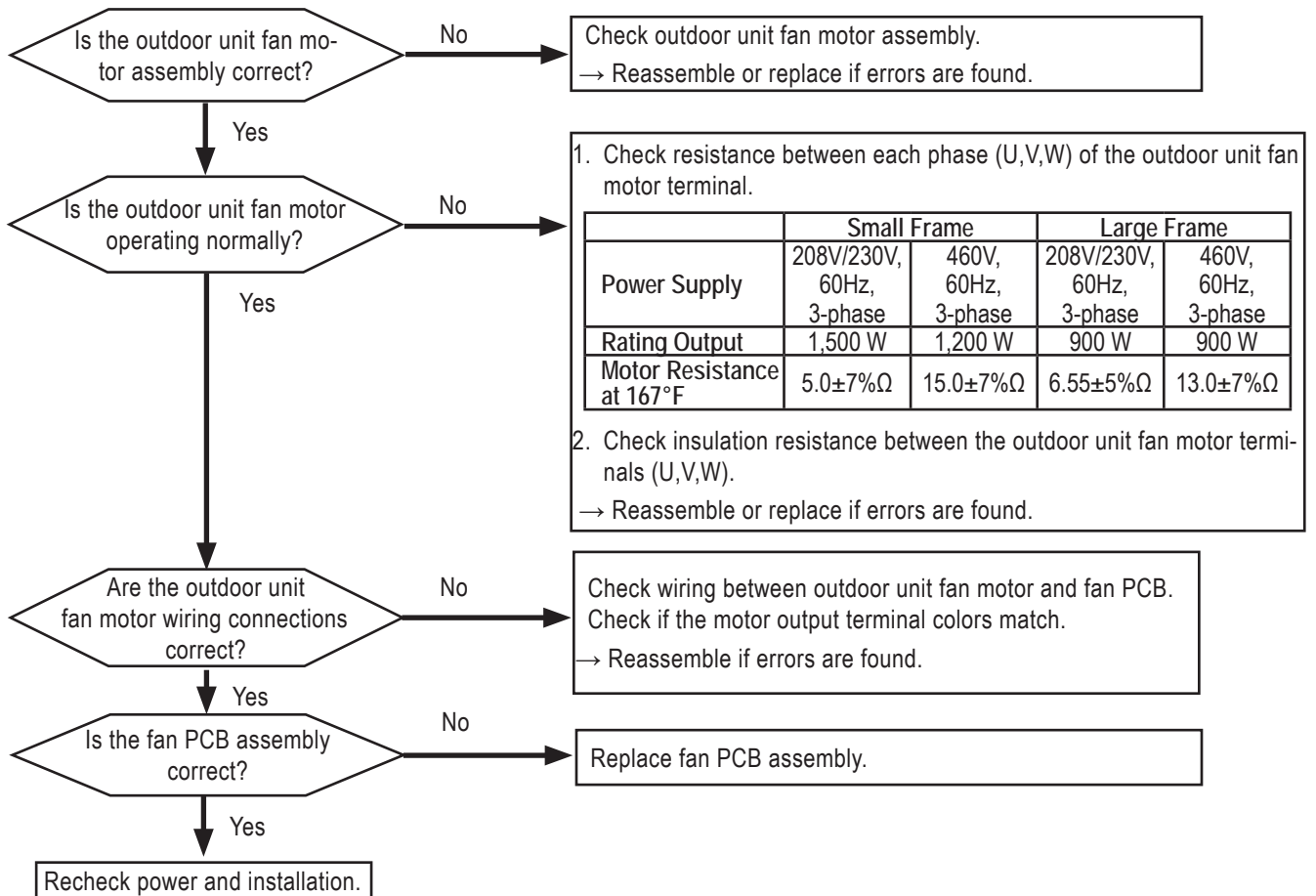

Check outdoor unit fan motor assembly.  
→ Reassemble or replace if errors are found.

1. Check resistance between each phase (U,V,W) of the outdoor unit fan motor terminal.

	Small Frame		Large Frame	
Power Supply	208V/230V, 60Hz, 3-phase	460V, 60Hz, 3-phase	208V/230V, 60Hz, 3-phase	460V, 60Hz, 3-phase
Rating Output	1,500 W	1,200 W	900 W	900 W
Motor Resistance at 167°F	5.0±7%Ω	15.0±7%Ω	6.55±5%Ω	13.0±7%Ω

2. Check insulation resistance between the outdoor unit fan motor terminals (U,V,W).  
→ Reassemble or replace if errors are found.

Check wiring between outdoor unit fan motor and fan PCB. Check if the motor output terminal colors match.  
→ Reassemble if errors are found.

Replace fan PCB assembly.

Recheck power and installation.

Measure fan motor resistance between each phase.



Fan motor wire connections.



**Note:**

If the outdoor unit is covered in thick snow, remove before operating system.

**Note:**

Images here are representative of system components. Actual component appearance depends on model and system type.

**⚠ WARNING** Please refer to the Safety Precautions on pages 4-7 for more detail to prevent injury or death regarding the operation and service troubleshooting of the Multi V product.

Error No.	Description	Details	Causes
71 Master: 711 Slave 1: 712 Slave 2: 713	Outdoor unit converter CT sensor error.	MICOM input voltage isn't within 2.5V±0.3V at initial power up.	1. Input voltage is not correct (R-T). 2. Damage to the outdoor unit converter PCB (CT sensor component).

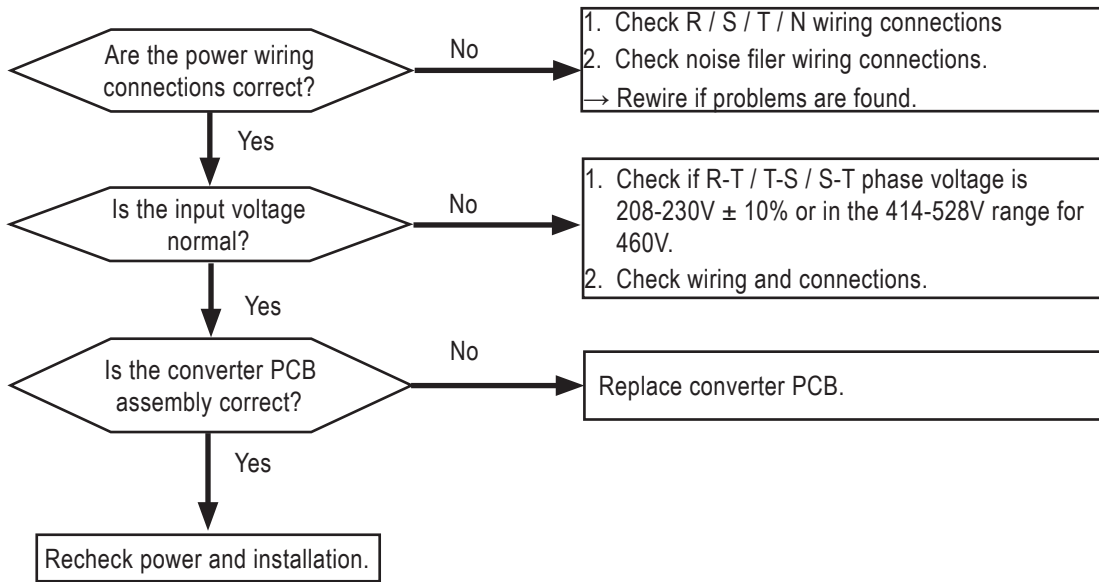

Error Codes

Measure Input Voltage.



Converter PCB Assembly.

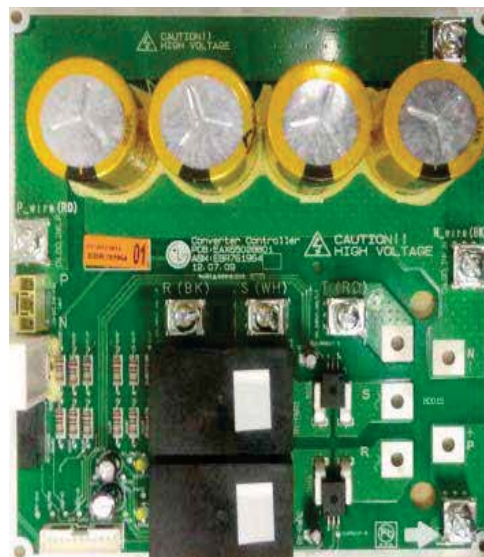

**Note:**

*Images here are representative of system components. Actual component appearance depends on model and system type.*

# ERROR CODES

## Error No. 75

**⚠ WARNING** Please refer to the Safety Precautions on pages 4-7 for more detail to prevent injury or death regarding the operation and service troubleshooting of the Multi V product.

Error No.	Description	Details	Causes
75 Master: 751 Slave 1: 752 Slave 2: 753	Fan CT sensor error.	Offset of MICOM; fan motor phase current is not $2.5V \pm 0.3V$ .	<ol style="list-style-type: none"> <li>1. Input voltage is not correct (not 15V).</li> <li>2. Fan PCB assembly is defective.</li> <li>3. Power wiring has disconnected or has shorted.</li> <li>4. Inverter PCB assembly is defective.</li> </ol>

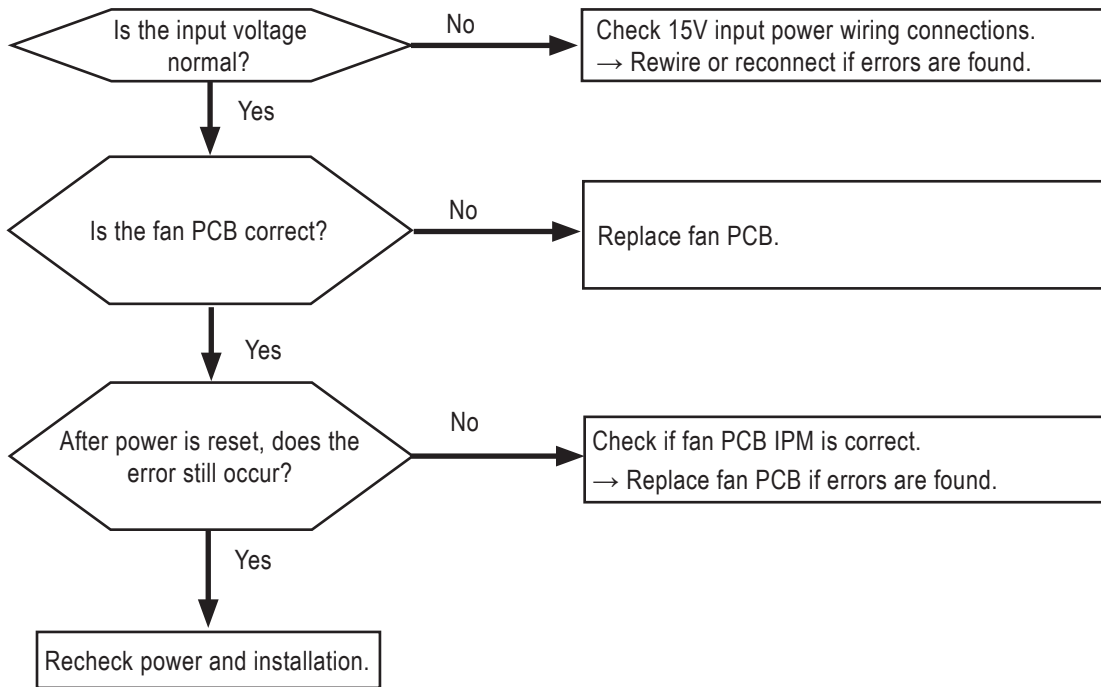

Check DC 15V input power on Inverter compressor PCB.

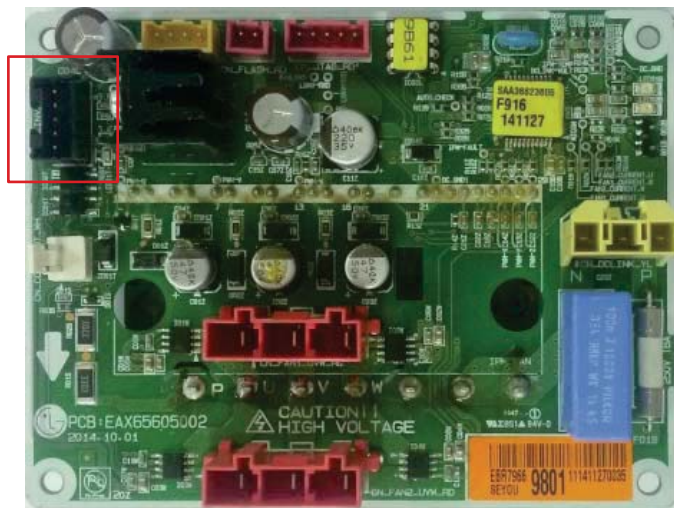

**Note:**

Images here are representative of system components. Actual component appearance depends on model and system type.

**⚠ WARNING** Please refer to the Safety Precautions on pages 4-7 for more detail to prevent injury or death regarding the operation and service troubleshooting of the Multi V product.

Error No.	Description	Details	Causes
77 Master: 771 Slave 1: 772 Slave 2: 773	Outdoor unit fan overcurrent error.	Outdoor unit fan current is >10A (for 208-230V units) or 5A (for 460V units).	<ol style="list-style-type: none"> <li>1. Overload operation.</li> <li>2. Fan motor is defective.</li> <li>3. Fan PCB assembly is defective.</li> <li>4. Fan motor connector is not inserted correctly.</li> <li>5. Condenser has iced up or is blocked.</li> </ol>

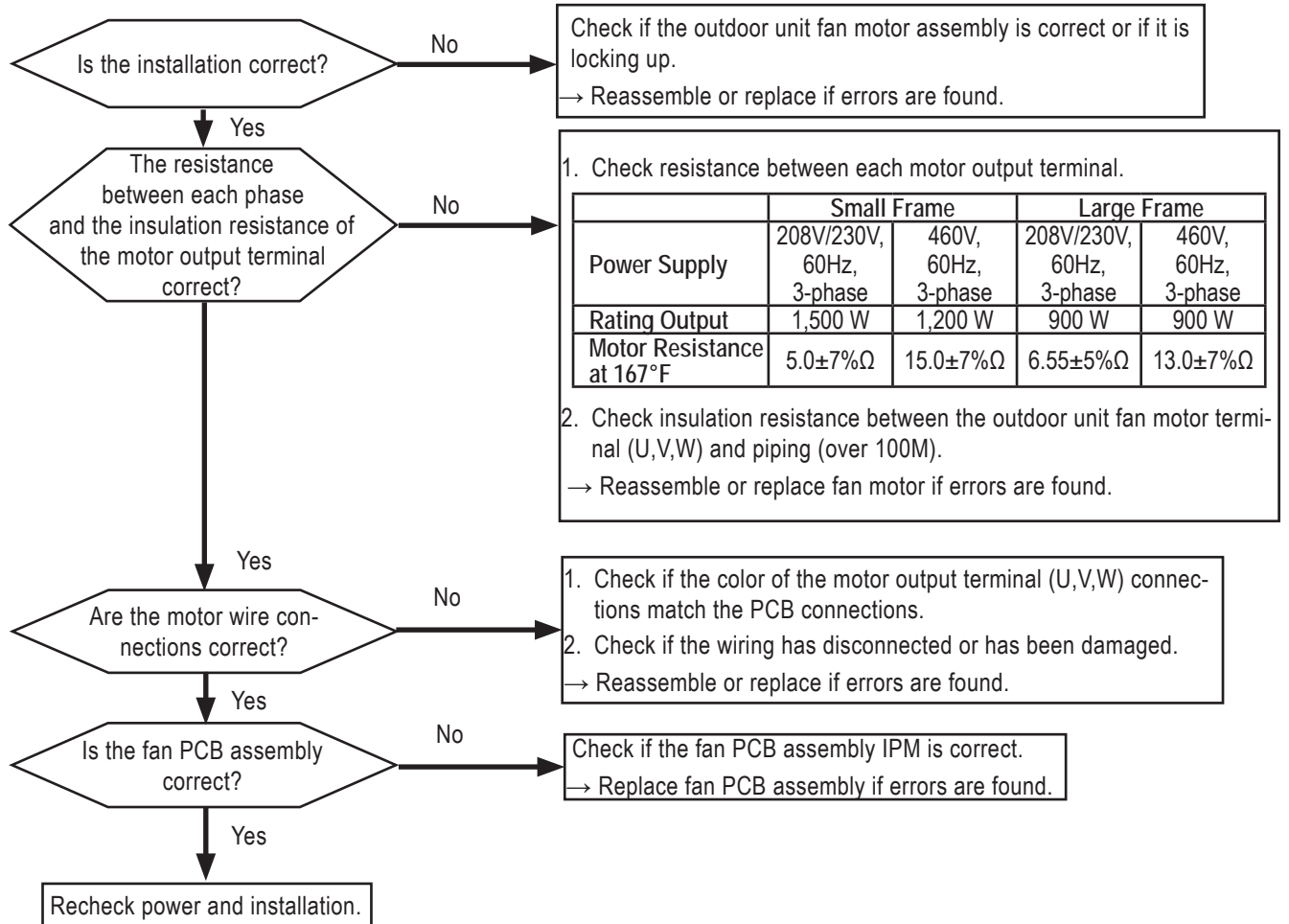

### Measure fan motor phase resistance.

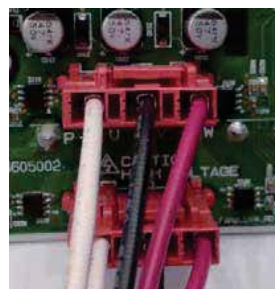

### Note:

Images here are representative of system components. Actual component appearance depends on model and system type.

# ERROR CODES

## Error No. 79

**⚠ WARNING** Please refer to the Safety Precautions on pages 4-7 for more detail to prevent injury or death regarding the operation and service troubleshooting of the Multi V product.

Error No.	Description	Details	Causes
79 Master: 791 Slave 1: 792 Slave 2: 793	Outdoor unit fan operation error.	Outdoor unit fan motor is experiencing first position sensor failure.	<ol style="list-style-type: none"> <li>1. Fan motor is defective or the assembly is not correct.</li> <li>2. Fan motor has disconnected (U,V,W output).</li> <li>3. Fan PCB is defective.</li> </ol>

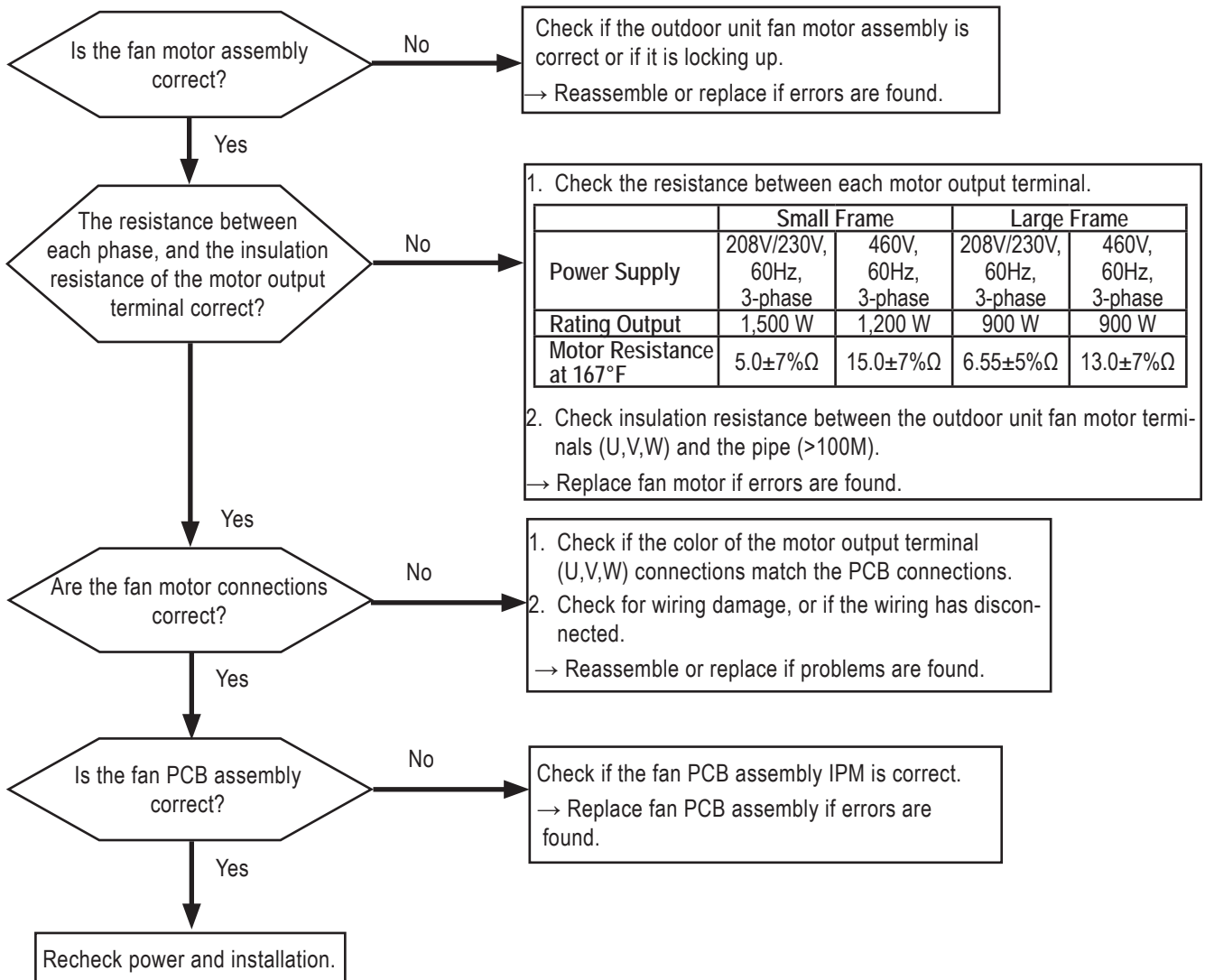

Error No. 79, continued.

**⚠ WARNING** Please refer to the Safety Precautions on pages 4-7 for more detail to prevent injury or death regarding the operation and service troubleshooting of the Multi V product.

---

---

Measure fan motor phase resistance.



Measure insulation resistance between fan terminal and chassis.

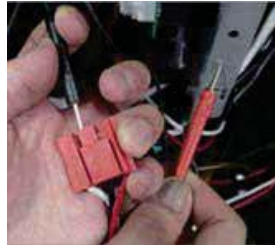

**Note:**

*Images here are representative of system components. Actual component appearance depends on model and system type.*

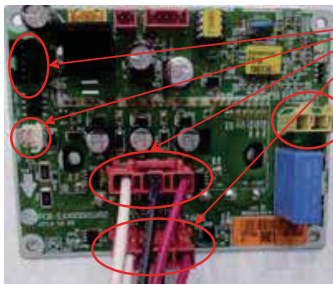

Check connections.

# ERROR CODES

## Error No. 86

**⚠ WARNING** Please refer to the Safety Precautions on pages 4-7 for more detail to prevent injury or death regarding the operation and service troubleshooting of the Multi V product.

Error No.	Description	Details	Causes
86 Master: 861 Slave 1: 862 Slave 2: 863	Outdoor unit main PCB onboard EEPROM error.	EEPROM access error.	1. No EEPROM. 2. EEPROM is not inserted properly.

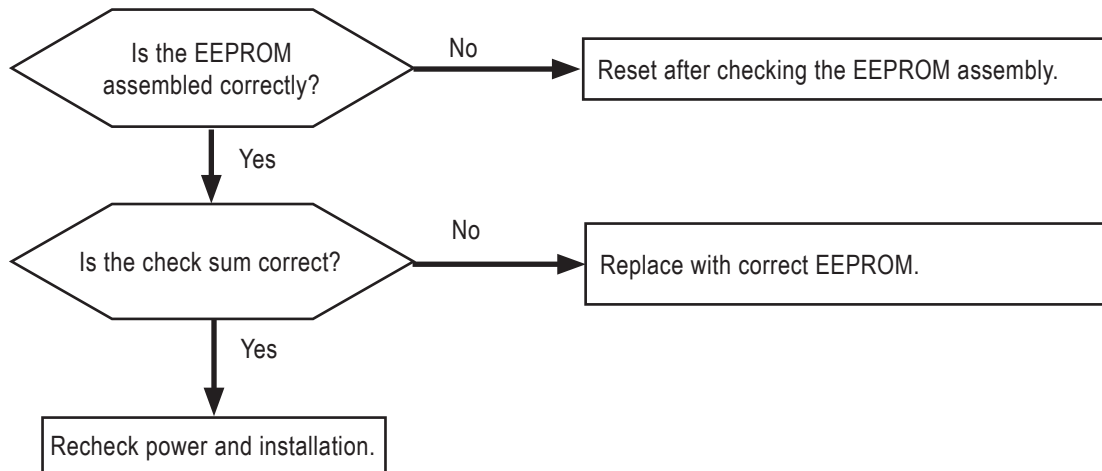

Inserting the EEPROM.

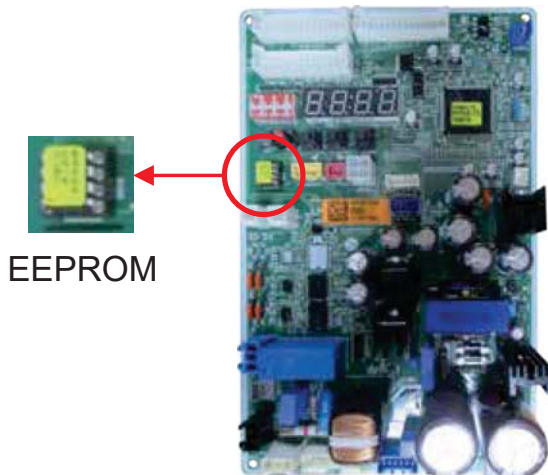

### ⚠ WARNING

Replace EEPROM only after the power is turned off. There is a risk of electric shock that could cause physical injury or death.

### Note:

Images here are representative of system components. Actual component appearance depends on model and system type.



Both the socket opening and the EEPROM opening must be in the same direction.

**⚠ WARNING** Please refer to the Safety Precautions on pages 4-7 for more detail to prevent injury or death regarding the operation and service troubleshooting of the Multi V product.

Error No.	Description	Details	Causes
87 Master: 871 Slave 1: 872 Slave 2: 873	Outdoor unit fan PCB EEPROM error.	Error occurs when checking the EEPROM check sum when at initial operating after power is supplied.	<ol style="list-style-type: none"> <li>EEPROM has a bad connection or was inserted incorrectly.</li> <li>Version of EEPROM is different.</li> <li>Outdoor unit fan PCB assembly may have been damaged after power was turned on.</li> </ol>

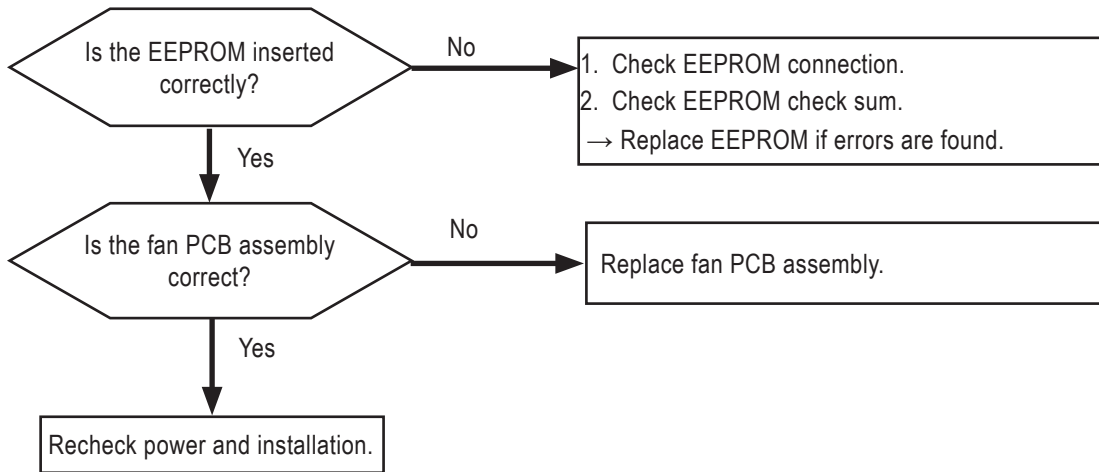

Check IC02L

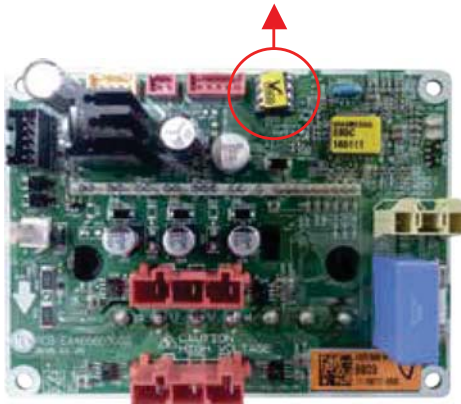

**⚠ WARNING**

Replace EEPROM only after the power is turned off. There is a risk of electric shock that could cause physical injury or death.

**Note:**

Images here are representative of system components. Actual component appearance depends on model and system type.

Direction of inserting the Inverter EEPROM.



Both the socket opening and the EEPROM opening must be in the same direction.

# ERROR CODES

## Error No. 104

**⚠ WARNING** Please refer to the Safety Precautions on pages 4-7 for more detail to prevent injury or death regarding the operation and service troubleshooting of the Multi V product.

Error No.	Description	Details	Causes
104 Master: 1041 Slave 1: 1042 Slave 2: 1043	Communication error between master outdoor unit and slave outdoor units.	Master unit displays outdoor unit number that has not been transmitting; slave unit displays its own error number.	<ol style="list-style-type: none"> <li>1. Power wiring / communication cable connections are loose. (Connections have disconnected or have shorted out).</li> <li>2. Outdoor unit main PCB is defective.</li> </ol>

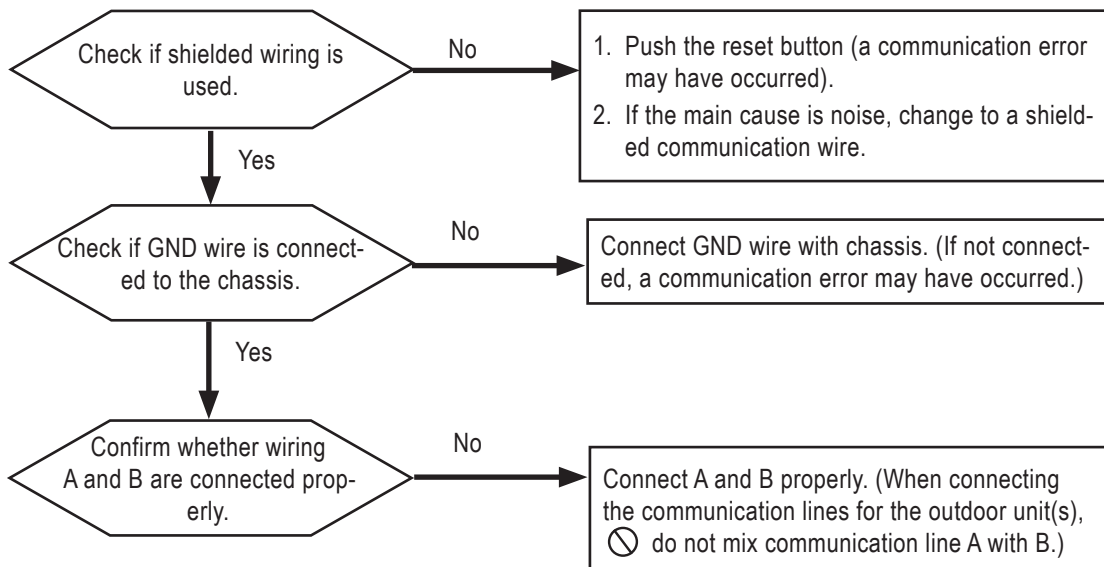
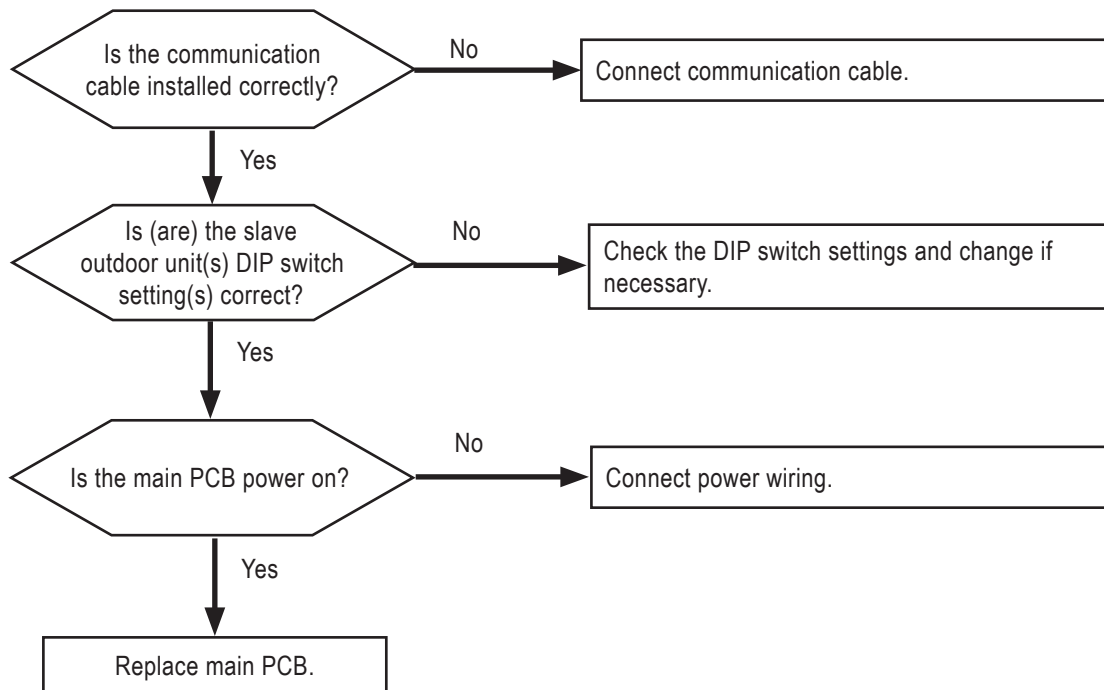

**⚠ WARNING** Please refer to the Safety Precautions on pages 4-7 for more detail to prevent injury or death regarding the operation and service troubleshooting of the Multi V product.

Figure 74: Error No. 104 Improper Connections.

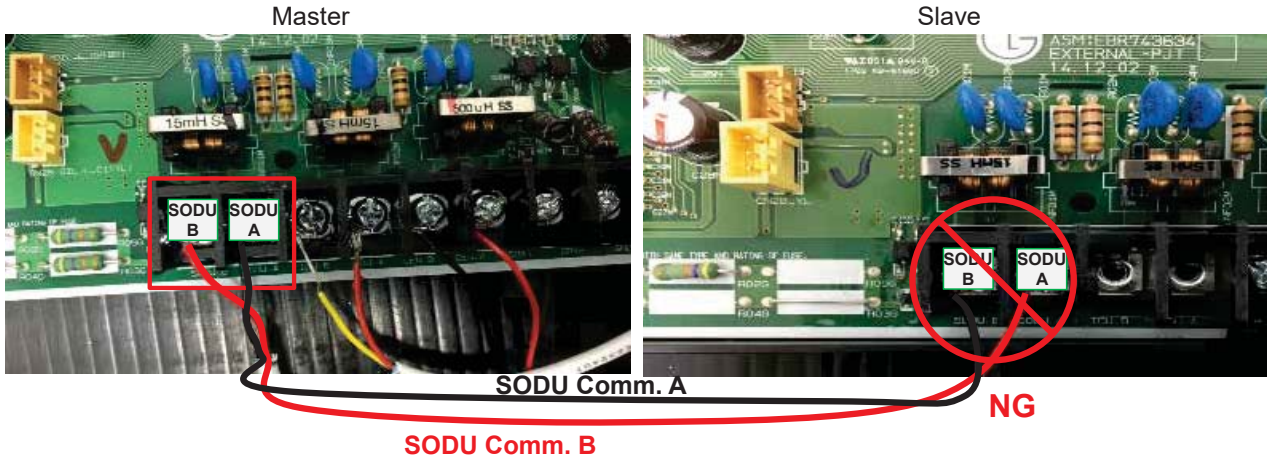

Table 82: Error No. 104 Improper Connections Checkpoint Details.

Cause	Check	Checklist				App.
		Check Point	Normal	Abnormal	Defective Parts	
External Noise Wrong Connection (Master ODU ↔ Slave ODU)	Push the reset button (If the cause in noise, communication will fail intermittently. Check if shielded wire is used or not.	Wire	Shield wire	Non-shielded wire	Wire / External Noise	B4 (Power Off)
	Check connection of GND wire from chassis	Wire	Connected from chassis	Non connected from chassis	-	
	Check whether wiring A and B is incorrect. (Master ODU ↔ Slave ODU)	ODU A,B Terminal Block	A-A, B-B	Cross connect A with B	-	
SMPS PCB Damaged	Check 5V Voltage (Comm. 5V)	Voltage	4.5V ~ 5.5V	4V ↓	SMPS PCB	A4 (Power On)
	Check Resistance of Communication IC	Resistance	1kΩ↑	1kΩ↓ ~ 0Ω	Main PCB	B4 (Power Off)
External PCB Damaged	Check whether patterns in external PCB are connected	Resistance	10Ω↓	Open	External PCB	

Error Codes

Figure 75: Checking Error No. CH104 from Main PCB (Communication IC) In Case of Power Off.

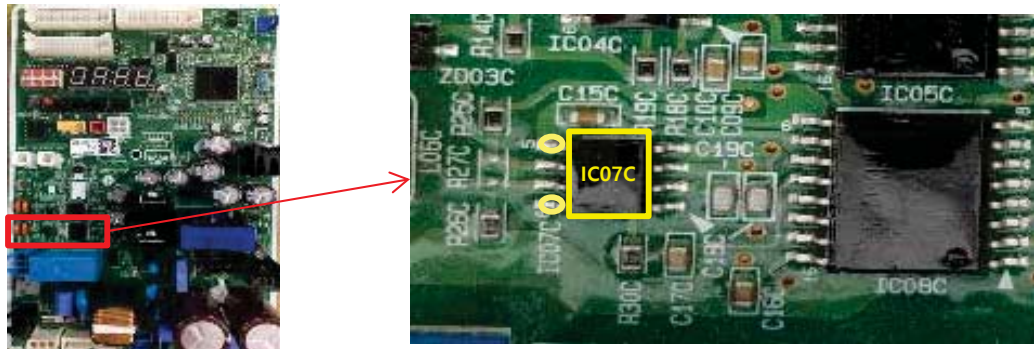

Figure 76: Multi-Meter (Note the Probe Color).



Table 83: Error No. 104 Main PCB (Communication IC) Checkpoint Details.

Check	Mode	Multi-Meter		Measured Value	
		Black	Red	Normal	Abnormal
IC07C	Ω	IC07C GND (pin 5)	IC07C Vcc (pin 8)	1kΩ↑	Not Normal

# ERROR CODES

## Error No. 104, continued.

**⚠ WARNING** Please refer to the Safety Precautions on pages 4-7 for more detail to prevent injury or death regarding the operation and service troubleshooting of the Multi V product.

Figure 77: Checking Error No. CH104 from External PCB.

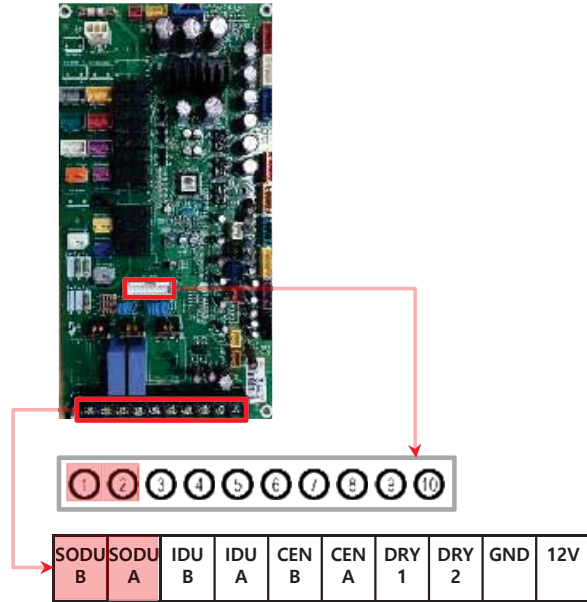
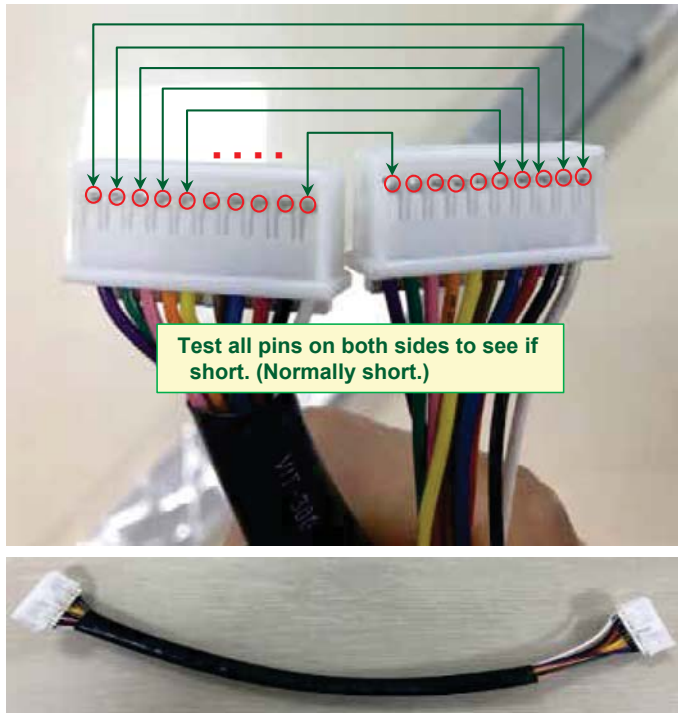

Table 84: Error No. 104 External PCB Checkpoint Details.

Check	Mode	Multi-Meter		Measured Value	
		Black	Red	Normal	Abnormal
PCB	$\Omega$	SODU B	Pin 1 – SODU B (White Connector)	10 $\Omega$ ↓	Open (Not Normal)
		SODU A	Pin 2 – SODU A (White Connector)		

Figure 78: Checking Error No. CH104 from Harness.



A 10 pin harness for connecting Main PCB with External PCB.

**⚠ WARNING** Please refer to the Safety Precautions on pages 4-7 for more detail to prevent injury or death regarding the operation and service troubleshooting of the Multi V product.

Error No.	Description	Details	Causes
105 Master: 1051 Slave 1: 1052 Slave 2: 1053	Communication error between fan PCB to inverter compressor PCB.	Fan PCB did not receive signal from inverter compressor PCB.	<ol style="list-style-type: none"> <li>1. Inverter compressor PCB and fan PCB connection is not correct.</li> <li>2. Fan PCB power is not supplied.</li> <li>3. Outdoor unit inverter compressor PCB and / or fan PCB is / are defective.</li> <li>4. Power supply PCB is not functioning properly; power to the inverter 1 and inverter 2 terminals on the main PCB is below 13.5 V DC.</li> </ol>

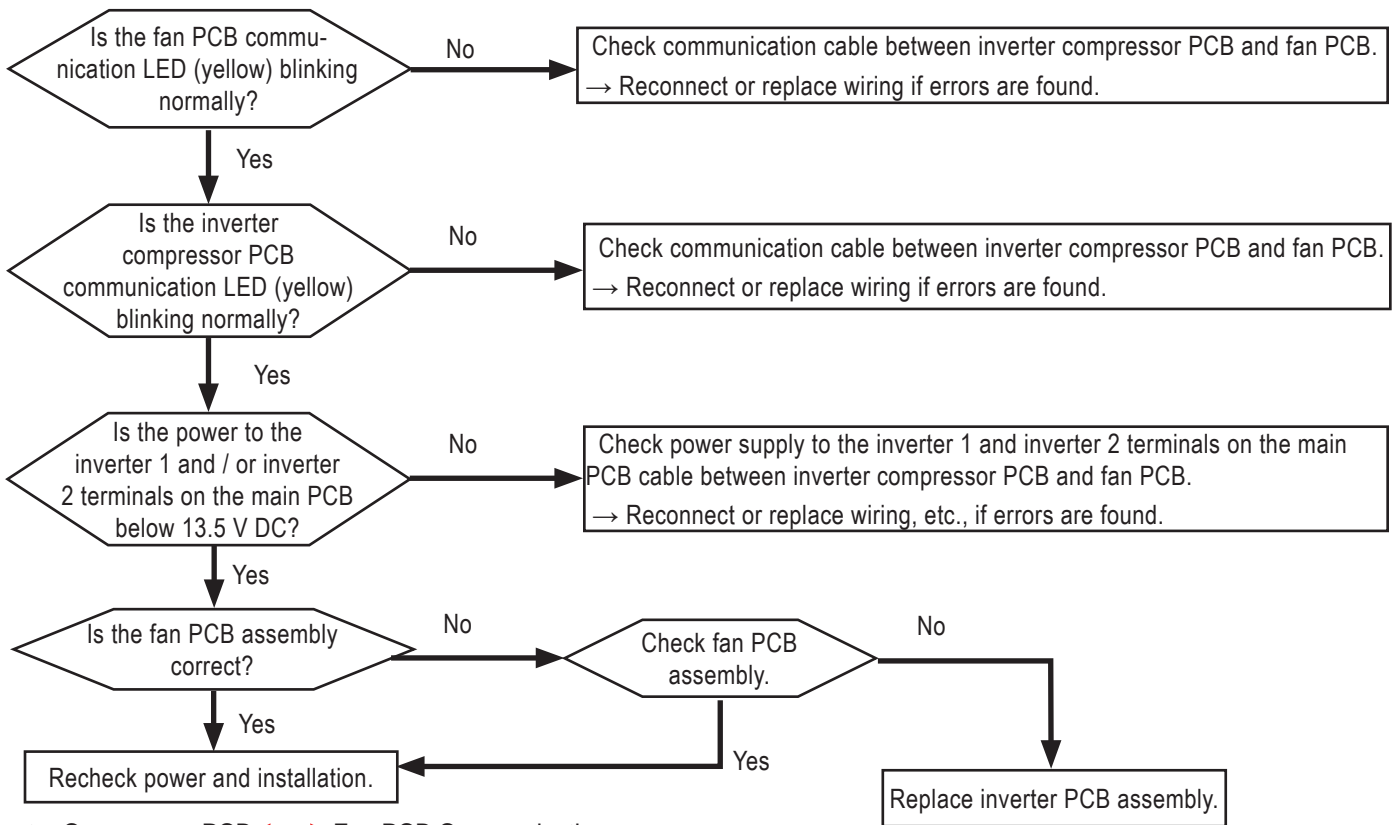

Inverter Compressor PCB ↔ Fan PCB Communication Connection



**Note:**

Communication Connection

Images here are representative of system components. Actual component appearance depends on model and system type.

# ERROR CODES

## Error No. 105, continued.

**⚠ WARNING** Please refer to the Safety Precautions on pages 4-7 for more detail to prevent injury or death regarding the operation and service troubleshooting of the Multi V product.

Table 85: Error No. 105 Checkpoint Details.

Cause	Check	Checklist			Defective Parts	App.
		Check Point	Normal	Abnormal		
Fan PCB Damaged	Check Fan PCB Appearance	Appearance	Good	Damage	Fan PCB	B3 (Power Off)
	Check Fuse	Fuse	Short	Open		
	Measure 5V,15V line	5V, 15V Resistance	10kΩ↑	1kΩ↓ ~ 0Ω		
	IPM (Check IGBT)	P-U,V,W / N-U,V,W	0.38V ~ 0.7V	Non-normal		
	Inverter Drive circuit (Check diode)	Diode	0.38V ~ 0.7V	Non-normal		
Inverter PCB Damaged	Check Inverter PCB Appearance	Appearance	Good	Damage	Inverter PCB	B1 (Power Off)
	Measure 5V,15V line	5V, 15V Resistance	10kΩ↑	1kΩ↓ ~ 0Ω		
	IGBTM (Check IGBT)	P-U,V,W / N-U,V,W	0.38V ~ 0.7V	Non-normal		
	Inverter Drive circuit (Check diode)	Diode	0.38V ~ 0.7V	Non-normal		

**⚠ WARNING** Please refer to the Safety Precautions on pages 4-7 for more detail to prevent injury or death regarding the operation and service troubleshooting of the Multi V product.

Error No.	Description	Details	Causes
106 Master: 1061 Slave 1: 1062 Slave 2: 1063	Outdoor unit fan PCB IPM error.	Outdoor unit fan IPM overcurrent protection circuit was activated.	<ol style="list-style-type: none"> <li>1. Overload operation (piping is clogged, fan is blocked, EEV is defective, refrigerant was overcharged).</li> <li>2. Outdoor unit fan motor assembly is not correct (coil is disconnected or has shorted out, insulation has been damaged).</li> <li>3. Defective fan PCB assembly.</li> <li>4. Power supply PCB is not functioning properly: power to the inverter 1 and inverter 2 terminals on the main PCB is below 13.5 V DC.</li> </ol>

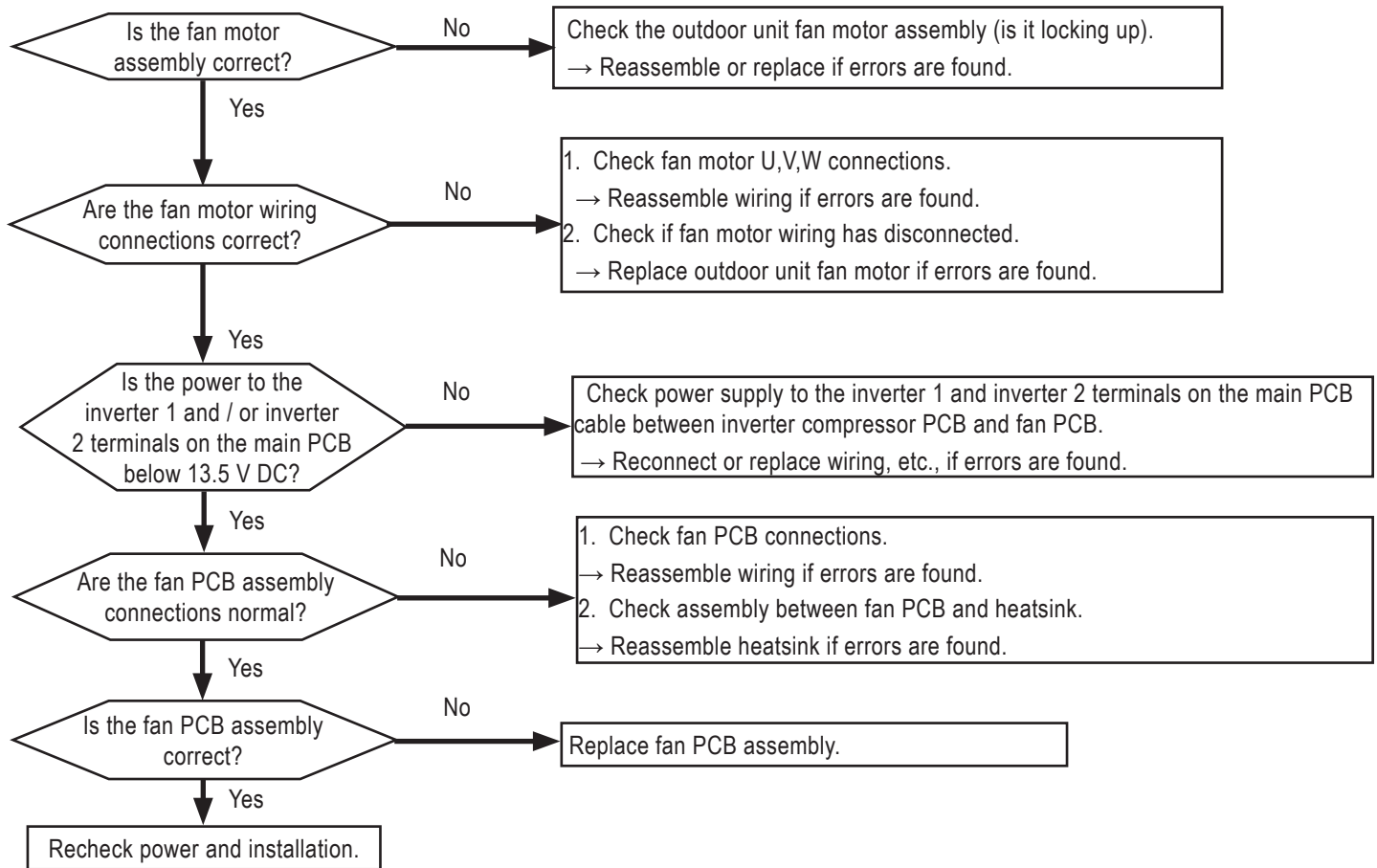

Fan motor wire connections.

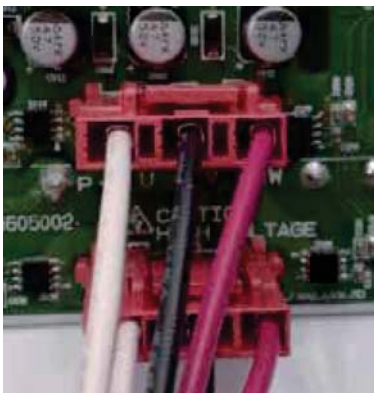

### Note:

Images here are representative of system components. Actual component appearance depends on model and system type.

# ERROR CODES

Error No. 106, continued.

**⚠ WARNING** Please refer to the Safety Precautions on pages 4-7 for more detail to prevent injury or death regarding the operation and service troubleshooting of the Multi V product.

Table 86: Error No. 106 Checkpoint Details.

Cause	Check	Checklist			Defective Parts	App.
		Check Point	Normal	Abnormal		
Fan PCB Damaged	Check Fan PCB Appearance	Appearance	Good	Damage	Fan PCB	B3 (Power Off)
	Check Fuse	Fuse	Short	Open		
	Measure 5V,15V line	5V, 15V Resistance	10kΩ↑	1kΩ↓ ~ 0Ω		
	IPM (Check IGBT)	P-U,V,W / N-U,V,W	0.38V ~ 0.7V	Non-normal		
	Inverter Drive circuit (Check diode)	Diode	0.38V ~ 0.7V	Non-normal		

**WARNING** Please refer to the Safety Precautions on pages 4-7 for more detail to prevent injury or death regarding the operation and service troubleshooting of the Multi V product.

Error No.	Description	Details	Causes
107 Master: 1071 Slave 1: 1072 Slave 2: 1073	Outdoor unit fan DC link low voltage error.	<ul style="list-style-type: none"> <li>Fan PCB DC link voltage supplied is &lt;140V (208-230V units) or &lt;380V (460V units).</li> <li>Outdoor unit fan DC link voltage is &lt;50V for a minimum of 250<math>\mu</math>s (for both 208-230V and 460V units).</li> <li>A capacitor that is serving the ODU fan inverter is not working properly, or the voltage at the capacitor is out of range (low). Start diagnosis at the inverter socket on the outdoor unit noise filter PCB.</li> </ul>	<ol style="list-style-type: none"> <li>Wiring is not installed correctly between the inverter PCB and the fan PCB.</li> <li>Fan PCB assembly is defective.</li> <li>Reactor terminal contact is defective.</li> <li>DC link terminal wiring and / or contact is defective / disconnected.</li> <li>Diode bridge is defective.</li> <li>Damaged electrical condenser component (serving capacitor) on inverter driver board.</li> </ol>

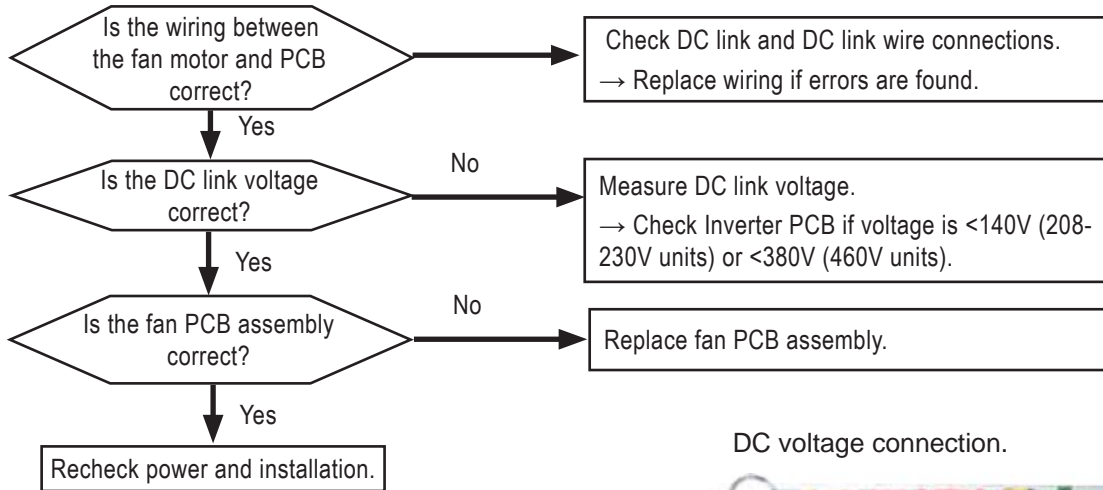

DC voltage connection.



DC voltage connected.

**Note:**

Images here are representative of system components. Actual component appearance depends on model and system type.

# ERROR CODES

## Error Nos. 113, 114, and 115

**▲WARNING** Please refer to the Safety Precautions on pages 4-7 for more detail to prevent injury or death regarding the operation and service troubleshooting of the Multi V product.

Error No.	Description	Details	Causes
113 Master: 1131 Slave 1: 1132 Slave 2: 1133	Outdoor unit liquid pipe (condenser) temperature sensor error.	Disconnection or short circuit of outdoor unit liquid pipe (condenser) temperature sensor (sensor value is abnormal).	<ol style="list-style-type: none"> <li>1. Defective temperature sensor connection.</li> <li>2. Temperature sensor has opened or shorted.</li> <li>3. Defective outdoor unit PCB.</li> </ol>
114 Master: 1141 Slave 1: 1142 Slave 2: 1143	Outdoor unit subcooling inlet temperature sensor error.	Disconnection or short circuit of outdoor unit subcooling inlet temperature sensor (sensor value is abnormal).	
115 Master: 1151 Slave 1: 1152 Slave 2: 1153	Outdoor unit subcooling outlet temperature sensor error.	Disconnection or short circuit of outdoor unit subcooling outlet temperature sensor (sensor value is abnormal).	

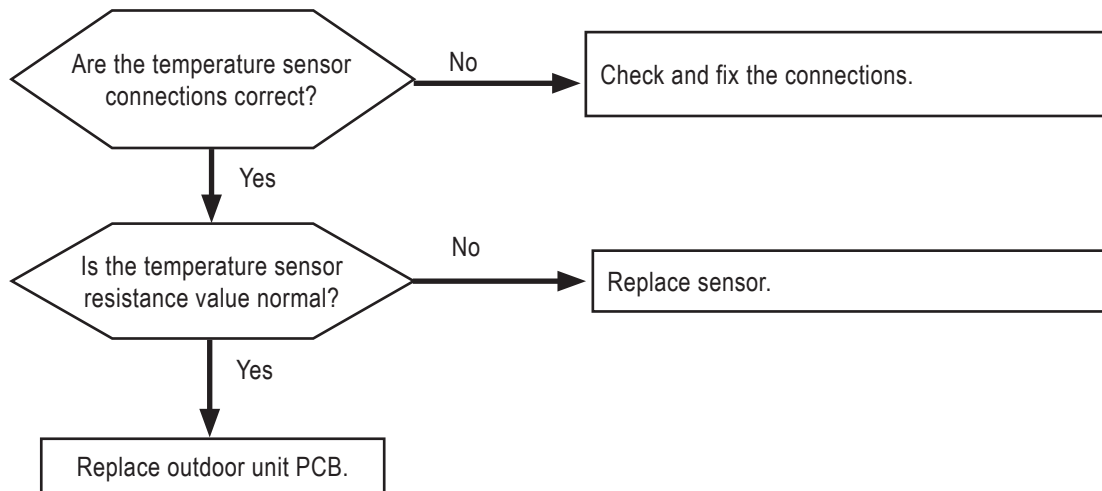

- If the value is  $>100\text{k}\Omega$  (open) or  $<100\Omega$  (short), there is an error.
- Sensor resistance value will vary with the temperature. See below for the resistance values according to temperature ( $\pm 5\%$  tolerance).
- Air temperature sensor:  $50^\circ\text{F} = 20.7\text{ k}\Omega$ ,  $77^\circ\text{F} = 10\text{ k}\Omega$ ,  $122^\circ\text{F} = 3.4\text{ k}\Omega$ .
- Pipe temperature sensor:  $50^\circ\text{F} = 10\text{ k}\Omega$ ,  $77^\circ\text{F} = 5\text{ k}\Omega$ ,  $122^\circ\text{F} = 1.8\text{ k}\Omega$ .

### Note:

See also Error Code No. 65: Outdoor Unit Liquid Pipe (Condenser) Temperature Sensor Error.

**⚠ WARNING** Please refer to the Safety Precautions on pages 4-7 for more detail to prevent injury or death regarding the operation and service troubleshooting of the Multi V product.

Error No.	Description	Details	Causes
145 Master: 1451 Slave 1: 1452 Slave 2: 1453	Communication error between outdoor unit main PCB and external PCB.	Cycle controller of outdoor unit PCB is not receiving signal from the external PCB.	<ol style="list-style-type: none"> <li>1. Power wiring and / or communication cables is / are not connected.</li> <li>2. Outdoor cycle controller / external PCB is / are defective.</li> </ol>

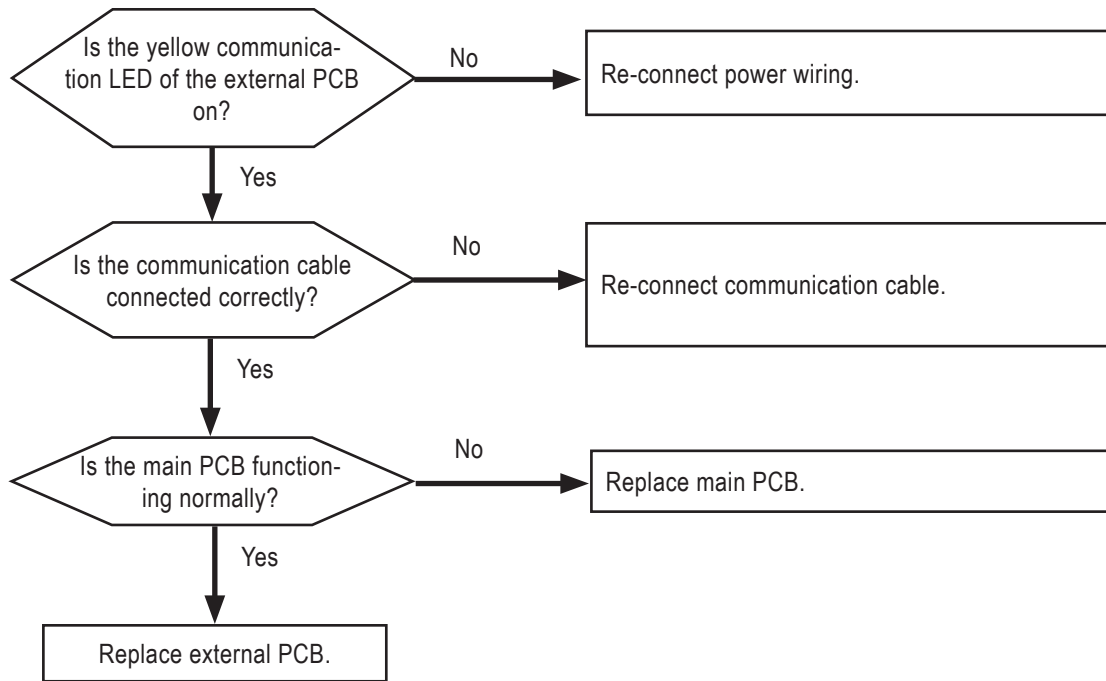

**Note:**

If the signal between the main PCB and the external PCB is normal, the communication LED on the external PCB blinks.

# ERROR CODES

## Error No. 150

**▲WARNING** Please refer to the Safety Precautions on pages 4-7 for more detail to prevent injury or death regarding the operation and service troubleshooting of the Multi V product.

Error No.	Description	Details	Causes
150 Master: 1501 Slave 1: 1502 Slave 2: 1503	Outdoor unit compressor discharge superheat not satisfied.	<p>Code indicates that based on current superheat measurements, there is a high possibility of liquid refrigerant flooding back and damaging the compressor.</p> <p>Discharge superheat is &lt;math&gt;4.8^{\circ}\text{F}&lt;/math&gt; (liquid bypass) for <math>\geq 5</math> minutes.</p> <p>Code can only occur when the outdoor is operating in cooling mode (all indoor units must be in cooling mode; error cannot occur during simultaneous operation).</p> <p>The first time superheat falls &lt;math&gt;4.8^{\circ}\text{F}&lt;/math&gt; (&lt;math&gt;3^{\circ}\text{C}&lt;/math&gt;) for 5 minutes, the system will shut down and CH150 is displayed on all indoor unit zone sensors and central control devices. After the initial occurrence, the outdoor unit cycles off and will auto-restart.</p> <p>Following the initial restart, and after 10 minutes of operation to allow the system time to stabilize, if the superheat again falls &lt;math&gt;4.8^{\circ}\text{F}&lt;/math&gt; (&lt;math&gt;3^{\circ}\text{C}&lt;/math&gt;) for 5 minutes, the system will shut down and auto restart for a second time.</p> <p>If error occurs 3 times within any 1 hour period of compressor operation, the error code will be assigned a Level 3, and the system will shut down and remain off. A manual restart will be necessary.</p>	<p>After at least 10 minutes of compressor operation, the master outdoor unit microprocessor will calculate the system's compressor superheat. If at any time during compressor operation where all indoor units in thermal on are in cooling mode and the compressor superheat falls &lt;math&gt;4.8^{\circ}\text{F}&lt;/math&gt; (&lt;math&gt;3^{\circ}\text{C}&lt;/math&gt;) for <math>\geq 5</math> minutes, there is a high probability that liquid could flood back to the inlet of the compressor scroll, resulting in compressor damage.</p> <ol style="list-style-type: none"> <li>1. Indoor unit EEV has disconnected or short circuited.</li> <li>2. Defective compressor EEV (large refrigerant leak has occurred).</li> <li>3. Defective liquid piping and / or vapor piping connections.</li> </ol>

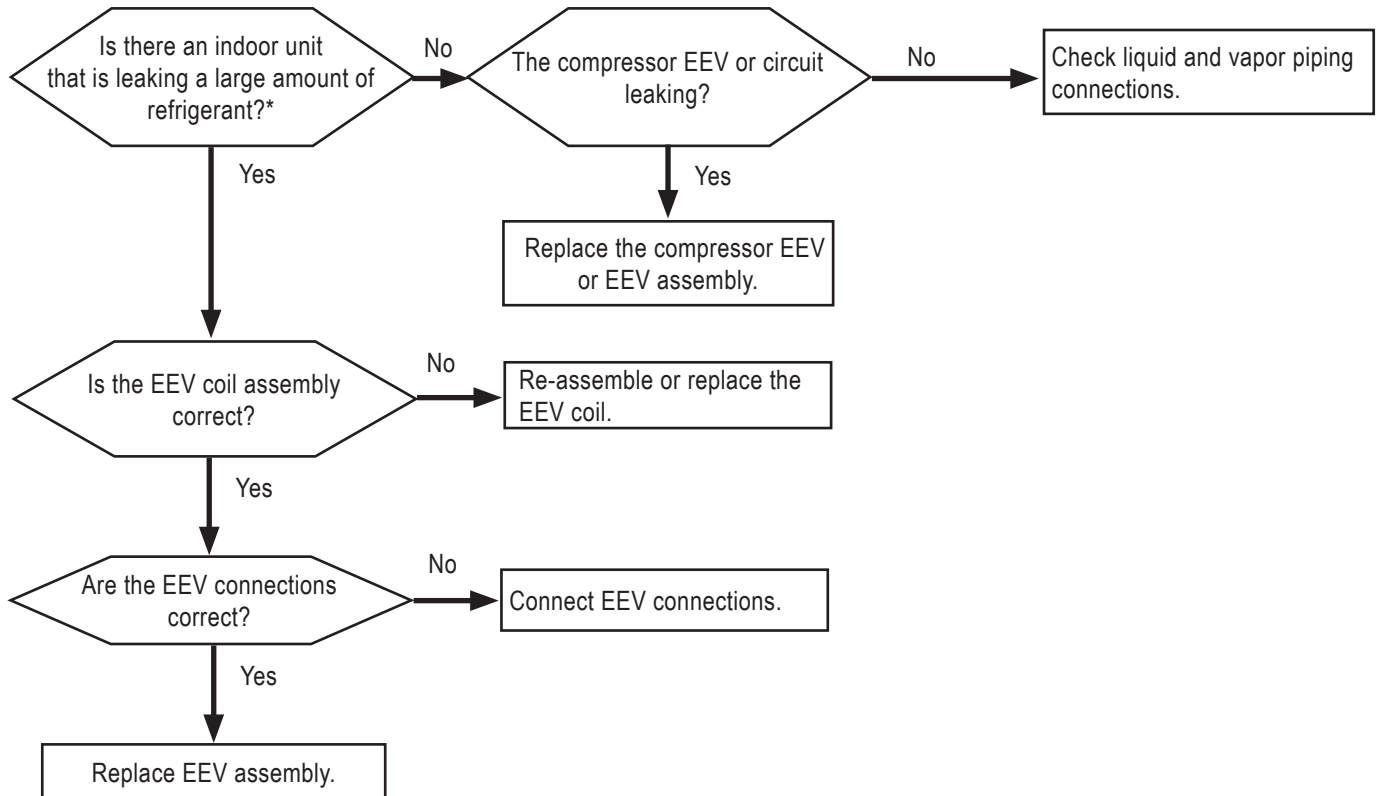

\*Excessive refrigerant leak: Both the piping inlet and outlet temperatures are <math>50^{\circ}\text{F}</math> when the indoor unit is off (EEV 40 pulses). Also, a loud refrigerant flow noise was heard.

**WARNING** Please refer to the Safety Precautions on pages 4-7 for more detail to prevent injury or death regarding the operation and service troubleshooting of the Multi V product.

Error No.	Description	Details	Causes
151 Master: 1511 Slave 1: 1512 Slave 2: 1513	The difference between the high and low pressure is too low.	Not enough pressure difference between high and low. Function error of outdoor unit four-way reversing valve.	<ol style="list-style-type: none"> <li>1. Problem with four-way valve operation because of sludge, inflow, etc.</li> <li>2. No pressure difference because of compressor error.</li> <li>3. Defective four-way valve (resistance is not <math>2,085\Omega \pm 10\%</math>).</li> </ol>

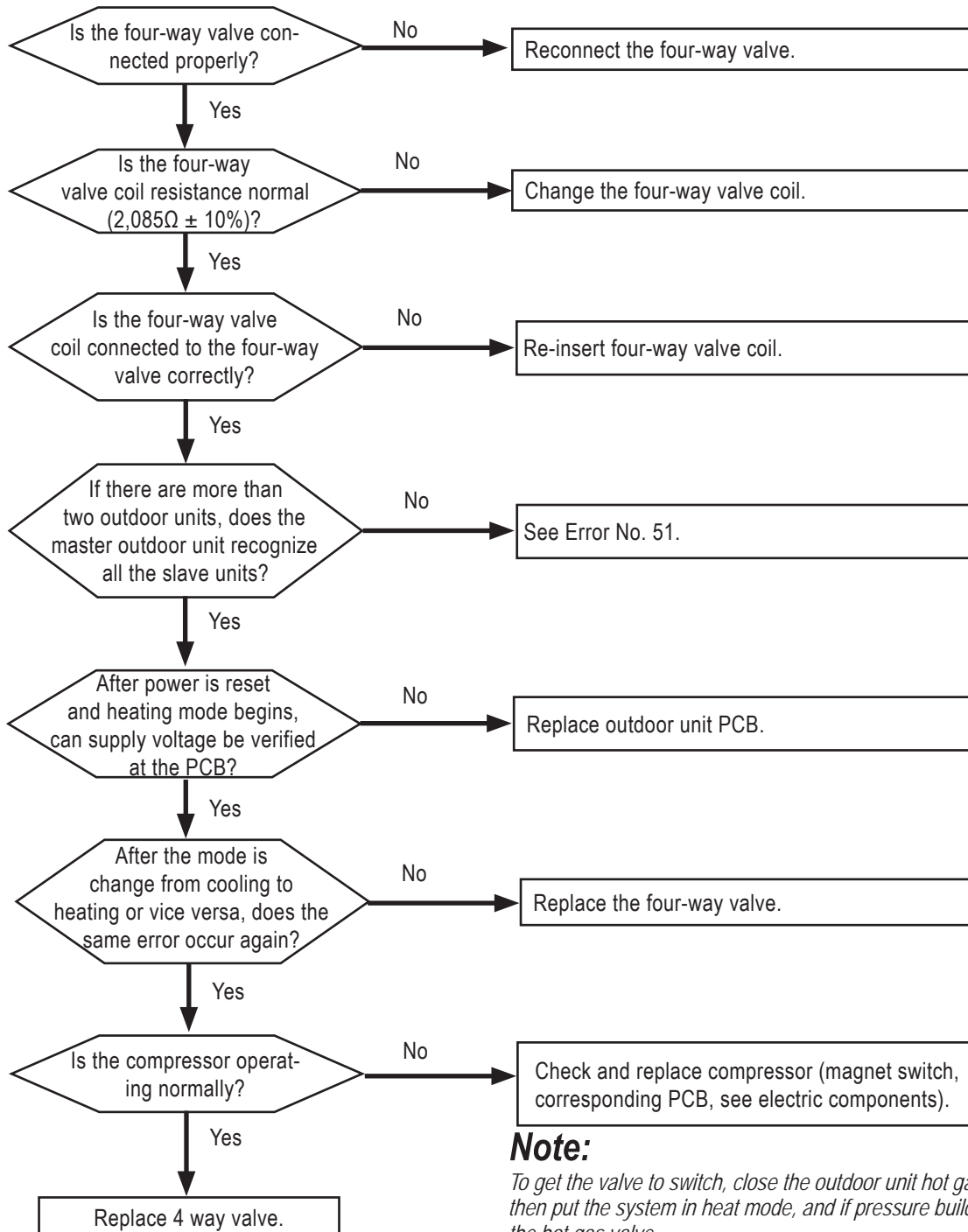

**Note:**

To get the valve to switch, close the outdoor unit hot gas service valve, then put the system in heat mode, and if pressure builds, slowly open the hot gas valve.

# ERROR CODES

## Error No. 151, continued.

**⚠ WARNING** Please refer to the Safety Precautions on pages 4-7 for more detail to prevent injury or death regarding the operation and service troubleshooting of the Multi V product.

Measure the four-way valve resistance.

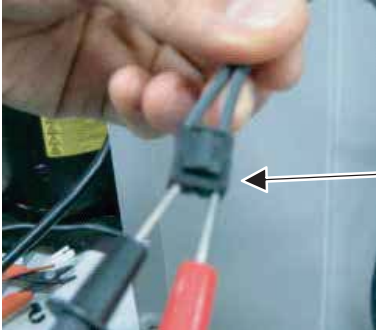

Location of the four-way valve connector on the Main PCB (marked as "4way, CN09").



Confirm the four-way valve coil is completely inserted.



Check the output voltage of the terminal socket during heating operation (output should be 230 V AC).

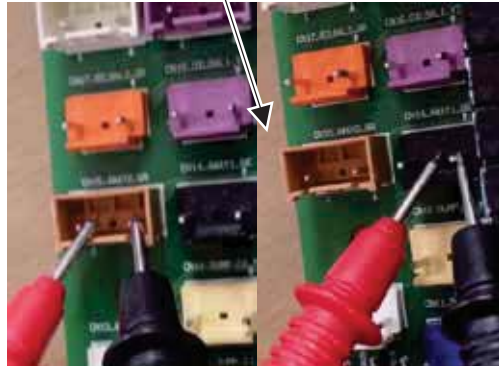

**⚠ WARNING** Please refer to the Safety Precautions on pages 4-7 for more detail to prevent injury or death regarding the operation and service troubleshooting of the Multi V product.

- Power is supplied to the outdoor units as follows: Slave 2 → Slave 1 → Master.
- Outdoor unit information is displayed in sequence at the main PCB SSD. See tables at below for code definitions.

Table 87: Display Code Definitions—Outdoor Unit Nominal Capacity.

Display Code	8	10	12	14	18	20	22	24	26	28	32	34	36	38	40	42
Nominal Mb/h	6	8	10	12	14	16	18	20	22	24	26	28	30	32	34	36

Table 88: Display Code Definitions—Voltage.

Outdoor Unit Code	22	46
Electrical Requirements	208-230V / 60Hz / 3Ø	460V / 60Hz / 3Ø

Table 89: Segment Display Sequence (Two [2] seconds per segment following a forty-five [45] second wait).

Sequence	Description	Code(s)	
1	Master Outdoor Unit Nominal Capacity	8 - 14*	
2	Slave1 Outdoor Unit Nominal Capacity	8 - 24*	
3	Slave2 Outdoor Unit Nominal Capacity	8 - ~*	
4	Total Nominal Capacity of System	8 - ~ *	
5	Unit Type	Heat Pump	2
		Heat Recovery	3
6	Unit Voltage	208-230V / 60Hz / 3Ø	22
		460V / 60Hz / 3Ø	46
7	Efficiency Level	1 or 2	

### Checking the Pressure Imbalance for a Three Outdoor Unit System (Master + Slave 1 + Slave 2)

1. Close all the service valves to the high pressure and low pressure piping.
2. Operate system.
3. View the difference between the high pressure and low pressure with LGMV for each outdoor unit (Master, Slave 1, Slave 2).
4. If there is an outdoor unit in which the difference between high pressure and low pressure did not increase, then the four-way valve of that outdoor unit is defective and must be replaced.

# ERROR CODES

## Error No. 182

**⚠ WARNING** Please refer to the Safety Precautions on pages 4-7 for more detail to prevent injury or death regarding the operation and service troubleshooting of the Multi V product.

Error No.	Description	Details	Causes
182 Master: 1821 Slave 1: 1822 Slave 2: 1823	Communication error between outdoor unit main and sub MICOMs of the external PCBs.	Outdoor unit main and sub MICOM communication failure.	Failure to receive signal between main and sub MICOMs.

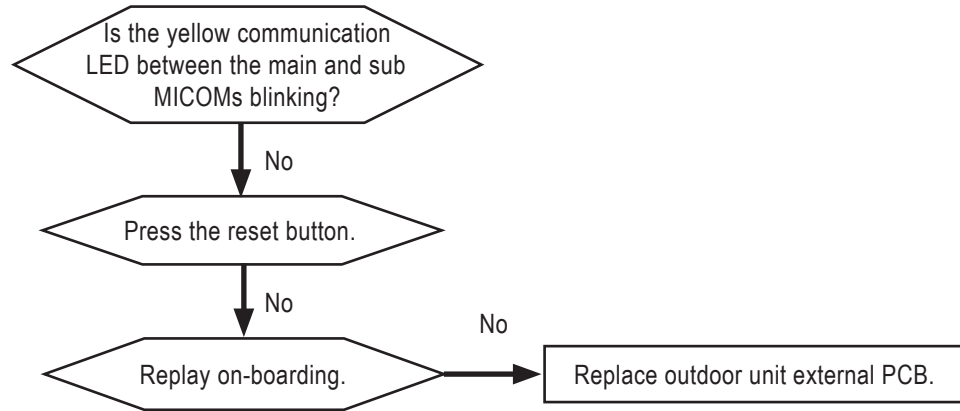

MULTI V 5 Outdoor Unit Service Manual

**⚠ WARNING** Please refer to the *Safety Precautions* on pages 4-7 for more detail to prevent injury or death regarding the operation and service troubleshooting of the Multi V product.

Error No.	Description	Details	Causes
187  Master: 1871 Slave 1: 1872 Slave 2: 1873	Hydro kit P, HEX error (P equals prevents from freezing).	Hydro kit error.	<ol style="list-style-type: none"> <li>1. Inlet water temperature is &lt;5°C (41°F). Raise error code – Level 3 response.</li> <li>2. Water outlet temperature sensor is disconnected or shorted. Values read less than -43°C or greater than +96°C (less than -45.4°F or greater than +204.8°F).</li> <li>3. Prevents HEX from bursting (from freezing) when operating. Does not protect HEX if the glycol is inadequate, nor if the hydro kit is off and not operating.</li> <li>4. Outdoor unit compressor ramps up, and hydro kit operates. One (1) minute later, pipe temperature at mid-temperature hot water supply (inlet or outlet water) is &lt;0°C (32°F), and mid-temperature hot water supply (inlet or outlet water) is ≤4°C (39.2°F) for ten (10) seconds.</li> </ol>

# ERROR CODES

## Error No. 193

**⚠ WARNING** Please refer to the Safety Precautions on pages 4-7 for more detail to prevent injury or death regarding the operation and service troubleshooting of the Multi V product.

Error No.	Description	Details	Causes
193 Master: 1931 Slave 1: 1932 Slave 2: 1933	Excessive increase in outdoor unit fan PCB heat sink temperature.	System has shut off because outdoor unit fan PCB heat sink temperature is >194°F.	<ol style="list-style-type: none"> <li>1. Fan PCB IPM connection is not correct.</li> <li>2. Outdoor unit fan motor is not operating correctly.</li> <li>3. Outdoor unit fan PCB assembly is defective.</li> <li>4. Overload operation (piping is clogged, fan is blocked, EEV is defective, overcharge in refrigerant).</li> </ol>

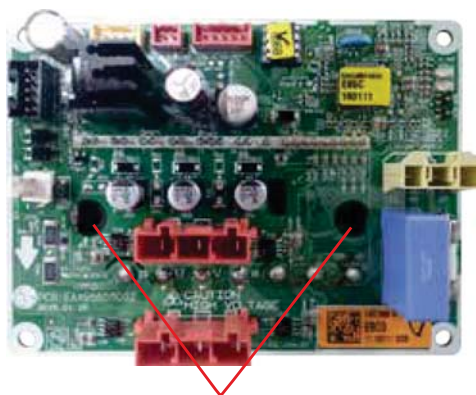
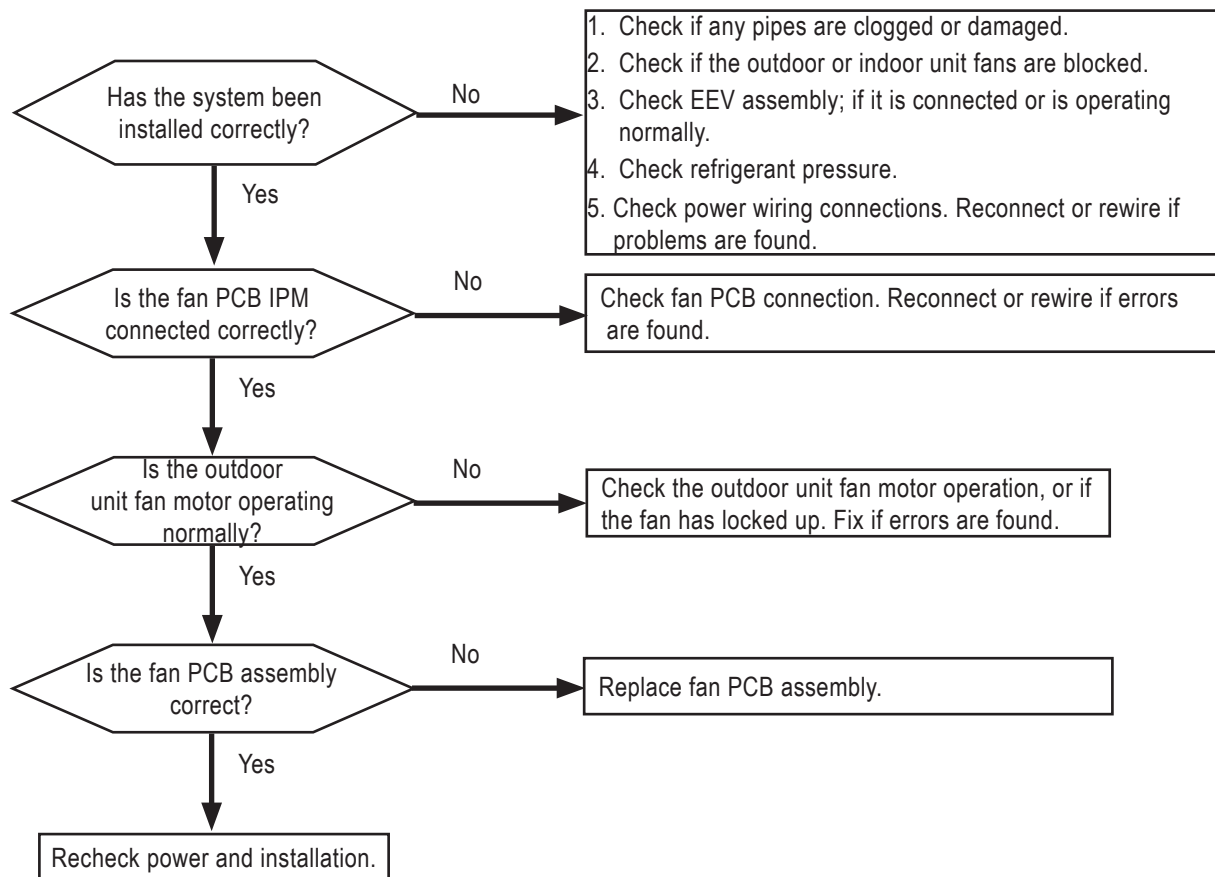

Check fan connection installation.

### Note:

Images here are representative of system components. Actual component appearance depends on model and system type.

**⚠ WARNING** Please refer to the Safety Precautions on pages 4-7 for more detail to prevent injury or death regarding the operation and service troubleshooting of the Multi V product.

Error No.	Description	Details	Causes
194 Master: 1941 Slave 1: 1942 Slave 2: 1943	Outdoor unit fan heatsink temperature sensor error.	Disconnection or short circuit of outdoor unit fan heatsink temperature sensor.	<ol style="list-style-type: none"> <li>1. Check sensor connection.</li> <li>2. Sensor is shorted or open.</li> <li>3. Defective outdoor unit PCB.</li> </ol>

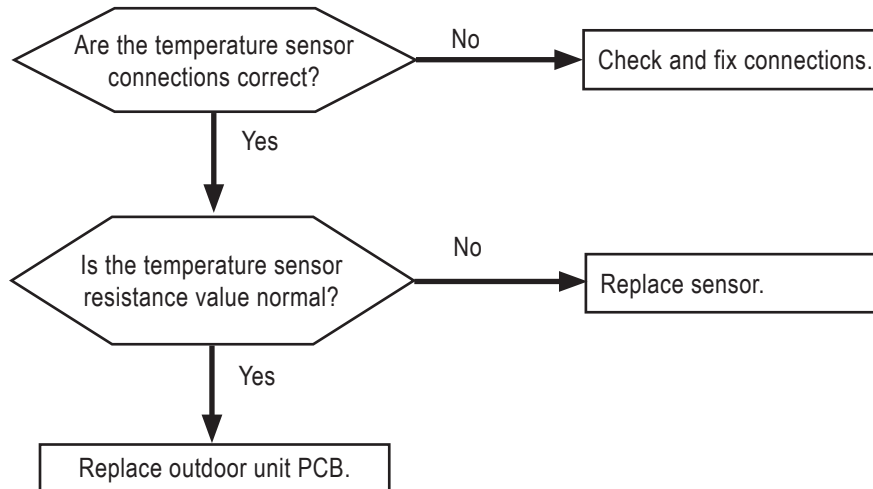

- If the value is >100kΩ (open) or <100Ω (short), there is an error.
- Sensor resistance value will vary with the temperature. See below for the resistance values according to temperature (±5% tolerance).
- Air temperature sensor: 50°F = 20.7kΩ, 77°F = 10kΩ, 122°F = 3.4kΩ.
- Pipe temperature sensor: 50°F = 10kΩ, 77°F = 5kΩ, 122°F = 1.8kΩ.

# ERROR CODES



**⚠ WARNING** Please refer to the Safety Precautions on pages 4-7 for more detail to prevent injury or death regarding the operation and service troubleshooting of the Multi V product.

Error No.	Description	Details	Causes
51 C+ No. (#) of Heat Recovery Unit	Capacity of indoor units connected to the heat recovery unit exceeds allowable limits.	Total capacity of indoor unit(s) connected to each heat recovery unit port exceeds allowable limits. Error code displays on the outdoor unit SSD, the heat recovery unit SSD, or in LGMV.	<p>After auto-pipe detection is complete, wait 5 minutes, then verify connected capacity. System will display error if:</p> <ul style="list-style-type: none"> <li>• The heat recovery unit port addresses are all unique, then &gt;54 Mbh single indoor unit connected; &gt;54 Mbh total of multiple indoor units connected.</li> <li>• If 2 heat recovery unit port addresses are the same and the ports are twinned; &gt;108 Mbh total of multiple indoor units are connected.</li> <li>• If 3 heat recovery unit port addresses are the same and the ports are all connected, &gt;162 Mbh total of multiple indoor units connected.</li> <li>• If the total connected indoor unit nominal capacity exceeds 192 Mbh for a single heat recovery unit.</li> </ul> <ol style="list-style-type: none"> <li>1. Communication cable or piping is not connected properly.</li> <li>2. Heat recovery PCB DIP switch is not set correctly.</li> <li>3. The indoor unit connected on the heat recovery unit port exceeds the allowable capacity limit.</li> </ol>

Error Code 51 C+ No. (#) of Heat Recovery Unit is displayed differently depending on which device it is viewed from:

1. If viewed from the master outdoor units SSD: The display shows "51c" where "c" is the heat recovery unit count number of the overconnected device assigned by auto-pipe detect.
2. If viewed from the heat recovery unit PCB board display that is overconnected: The display will show "CH51".
3. If viewed from an heat recovery unit that is not overconnected: The display will show nothing.
4. If viewed from any indoor unit zone controller: Nothing will be displayed.
5. If viewed from LGMV maintenance software on a PC: The screen will show CH51h where "h" is the heat exchanger address of the overconnected heat recovery unit.

1. Check if the communication cable and piping between the heat recovery unit(s) and the indoor unit(s) installed correctly.
2. Check if the DIP switches are set correctly for each connection condition between the heat recovery unit(s) and the indoor unit(s).
3. If the indoor unit connected to the heat recovery unit IS in a group control application, check if the corresponding capacity is  $\leq 100$  kBtu.
4. If the indoor unit connected to the heat recovery unit IS NOT in a group control application, check if the corresponding capacity is  $\leq 56$  kBtu (including zoning control).
5. If the error occurs again even after following Steps 1 through 4 above, replace the corresponding heat recovery unit PCB.
6. When Steps 1 through 4 (or Steps 1 through 5 if the heat recovery unit PCB needs to be replaced) are completed successfully, perform the auto addressing and piping detection procedures.

**⚠ WARNING** Please refer to the Safety Precautions on pages 4-7 for more detail to prevent injury or death regarding the operation and service troubleshooting of the Multi V product.

**Error No. 51 C**

Error No.	Description	Details	Causes
2001	Auto pipe search failure.	After auto operation, the number of the indoor units detected is different from the number of communicating indoor units.	<ol style="list-style-type: none"> <li>1. Power wiring or the communications cable to the heat recovery unit is defective.</li> <li>2. After auto addressing, indoor unit has the wrong address (defective indoor unit PCB and / or power wiring / communications cable).</li> <li>3. Heat recovery unit rotary or DIP switch setting(s) is (are) wrong.</li> <li>4. Heat recovery unit PCB is defective.</li> </ol>

1. See if the green communication LED of the heat recovery unit is blinking.
2. If the green communication LED of the heat recovery unit is consistently blinking:
  - Check the input power of the heat recovery unit.
  - Reset power to the outdoor unit and heat recovery unit, wait for ≥thirty (30) minutes so the piping temperature will cool down, and then perform the auto addressing procedure.
  - While the power to the heat recovery unit is on, check if error code “CH05” is displayed (see troubleshooting instructions for Error No. CH05).
3. If the green communication LED of the heat recovery unit is still consistently blinking, check the rotary switch and DIP switch settings. Reset power to the outdoor unit and heat recovery unit, wait for ≥thirty (30) minutes so the piping temperature will cool down, and then perform the auto addressing procedure.
4. If the number of indoor units is different than what is actually installed and what number is displayed after the auto addressing procedure is finished, check the piping installation. Outdoor unit ↔ Heat Recovery unit ↔ Indoor unit.
5. If an indoor unit has not been connected to the first port (No. 1 Valve) of the heat recovery unit, set the heat recovery unit piping manually.

**Note:**

During initial system commissioning (or re-commissioning) Error No. CH200: Pipe Detection Error – failure to find indoor unit”, by default, calls for an immediate shutdown without first performing any auto restart attempts. For more information on CH200, see also Service Function SE14 in the Outdoor Unit Functions section.

# ERROR CODES



## Error Nos. 201C, 202C, 203C

**⚠ WARNING** Please refer to the Safety Precautions on pages 4-7 for more detail to prevent injury or death regarding the operation and service troubleshooting of the Multi V product.

Error No.	Description	Details	Causes
201 C+ No. (#) of Heat Recovery Unit	Heat recovery unit liquid piping temperature sensor error.	Abnormal sensor value (sensor has disconnected or has shorted out).	<ol style="list-style-type: none"> <li>1. Defective temperature sensor connection.</li> <li>2. Defective temperature sensor (sensor has disconnected or has shorted out).</li> <li>3. Defective outdoor unit PCB.</li> </ol>
202 C+ No. (#) of Heat Recovery Unit	Heat recovery unit subcooling inlet piping temperature sensor error.		
203 C +No. (#) of Heat Recovery Unit	Heat recovery unit subcooling discharge piping temperature sensor error.		

1. Check the connections of the temperature sensor and the lead cable.
2. Is the value of temperature sensor normal? If not, replace sensor (piping temperature sensor: 50°F = 10 kΩ, 77°F = 5 kΩ, 122°F = 1.8 kΩ).
3. If the sensor connection and values are correct, replace the outdoor unit PCB.

Heat Recovery Unit	HR No. 1	HR No. 2	HR No. 3	HR No. 4	HR No. 5	HR No. 6	HR No. 7	HR No. 8	HR No. 9	HR No. 10	HR No. 11	HR No. 12	HR No. 13	HR No. 14	HR No. 15	HR No. 16
Error Displayed	C01	C02	C03	C04	C05	C06	C07	C08	C09	C10	C11	C12	C13	C14	C15	C16

### Example of Heat Recovery R unit Error

- #16 Heat Recovery Unit Subcooling Inlet Piping Temperature Sensor Error 200→C16 (Repeated).
- C = Heat Recovery Unit
- # = Heat Recovery Unit Number

**⚠ WARNING** Please refer to the Safety Precautions on pages 4-7 for more detail to prevent injury or death regarding the operation and service troubleshooting of the Multi V product.

Error No.	Description	Details	Causes
204 C+ No. (#) of Heat Recovery Unit	Communication error between outdoor unit and heat recovery unit.	Outdoor unit does not receive signal from heat recovery unit.	<ol style="list-style-type: none"> <li>Heat recovery unit power wiring and / or communication cable connections are defective.</li> <li>Heat recovery unit rotary or DIP switch setting(s) is (are) wrong.</li> <li>Defective heat recovery unit communications PCB (sub PCB).</li> <li>Defective heat recovery unit main PCB.</li> </ol>

- If Error No. 59 is displayed on the heat recovery unit, and Error No. 204 is displayed on the outdoor unit, these indicate that the outdoor unit software has NOT been upgraded to support heat recovery unit 3A models. Contact your LG representative for information.
- Check power wiring and communication cable connections. Check if the green communication LED on the heat recovery unit PCB is blinking.
- If the green communication LED is blinking normally, check the rotary and DIP switch settings on the heat recovery unit (See Error No. 200). Reset the power to the outdoor and heat recovery units. (If there is a heat recovery unit communication error, it can't be released until the power to the outdoor unit is reset.)
- If the green communication LED of the heat recovery unit PCB is not blinking (on continuously), check if the communication of the total indoor units is normal (See Error No. 05). If the green communication LED of the heat recovery unit PCB is not blinking (on continuously), and even if communication to the indoor unit is functioning, replace the heat recovery unit PCB.

**⚠ DANGER**

- High voltage electricity is required to operate this system. Adhere to the NEC code and these instructions when wiring. Improper connections and inadequate grounding can cause accidental injury or death.
- Turn the power off before servicing the equipment. Electrical shock can cause physical injury or death.
- ⚡ Do not operate the disconnect switch with wet hands. There is risk of fire, electric shock, physical injury or death.

**⚠ WARNING**

- Disconnects must only be performed by a properly licensed electrician. Incorrect wiring could cause the disconnect to explode, leading to physical injury or death.
- ⚡ Do not operate the unit with the panel(s) or protective cover(s) removed. The hot, cold, and high-voltage parts of the unit can cause physical injury or death.
- ⚡ Do not touch the refrigerant piping during or after operation. It can cause burns or frostbite.

**Note:**

- If the power wiring and communication cables on the heat recovery unit(s) and indoor unit(s) are not properly connected (connections switched), the communication components will burn out.
- ⚡ Do not supply power to the unit until all electrical wiring and controls wiring are completed.

Heat Recovery Unit PCB

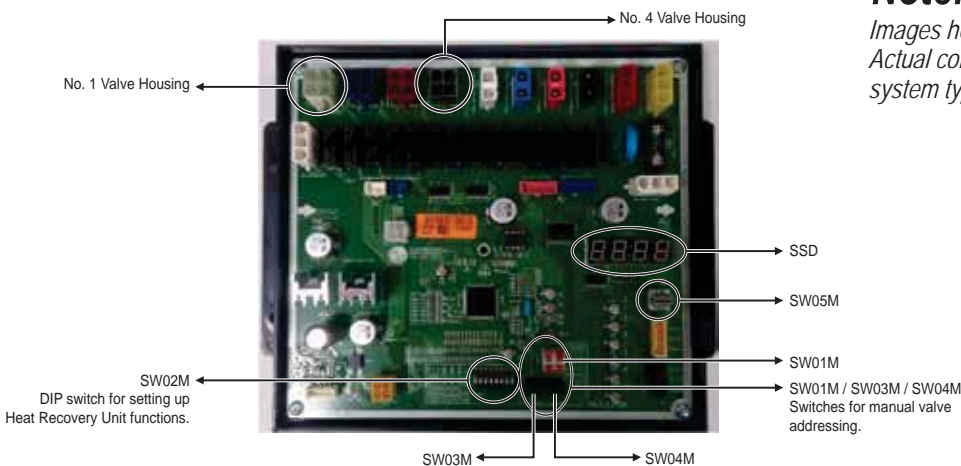

**Note:**

Images here are representative of system components. Actual component appearance depends on model and system type.

# ERROR CODES

## Error No. 205 C

**⚠ WARNING** Please refer to the Safety Precautions on pages 4-7 for more detail to prevent injury or death regarding the operation and service troubleshooting of the Multi V product.

Error No.	Description	Details	Causes
205 C+ No. (#) of Heat Recovery Unit	Communication error between heat recovery unit and the 485 modem (2A Series Heat Recovery Units).	<p>Communication error occurred between the heat recovery unit and the 485 modem (2A Series Heat Recovery Units).</p> <p>The 2A Series heat recovery unit applies only to heat recovery systems communicating at a baud rate of 9,600 bps.</p> <p>The 485 modem is the communications style on the bus that is 1e outdoor unit to many indoor units.</p>	<ol style="list-style-type: none"> <li>1. Communication problem occurred between the heat recovery unit PCB and the connection to the communications bus (the heat recovery unit 485 modem).</li> <li>2. Error displays if the outdoor unit signal is not received for three (3) minutes. The error clears after the signal is received from the modem. (2A Series Heat Recovery Units.)</li> <li>3. Incorrect wiring between the heat recovery unit and the 485 modem.</li> <li>4. The 485 PCB modem is defective.</li> <li>5. The heat recovery unit PCB is defective.</li> </ol>

1. Check the communication cable connection between the heat recovery unit (2A Series) and the 485 modem. Check if the red LED is on.
2. If the red LED on the 485 modem is on, reset the outdoor unit and the power of the heat recovery unit.
3. If the red LED on the 485 modem is flashing, replace the 485 modem.
4. If the red LED on the 485 modem still flashes even after it is replaced, replace the heat recovery unit PCB.

**⚠ WARNING** Please refer to the Safety Precautions on pages 4-7 for more detail to prevent injury or death regarding the operation and service troubleshooting of the Multi V product.

Error No.	Description	Details	Causes
206 C+ No. (#) of Heat Recovery Unit	Duplicate address error of the heat recovery unit (2A Series).	<p>The heat recovery unit address is duplicated for 485 communication (2A Series Heat Recovery Units).</p> <ul style="list-style-type: none"> <li>• The 2A Series heat recovery unit applies only to heat recovery systems communicating at a baud rate of 9,600 bps.</li> <li>• The 485 modem is the communications style on the bus that is 1e outdoor unit to many indoor units.</li> </ul>	<ol style="list-style-type: none"> <li>1. A heat recovery unit address is duplicated for 485 communication.</li> <li>2. There are two heat recovery units with one or more HEX addresses that are the same.</li> <li>3. Adjust the HEX address dial found on the heat recovery units (error of the rotary switch address settings on the heat recovery unit).</li> <li>4. The power wiring and / or the communication cable connection of the heat recovery unit is defective.</li> <li>5. The heat recovery unit PCB is defective.</li> </ol>

1. Check if the rotary switch settings on each heat recovery unit PCB are set correctly. If not, set the rotary switches again, verifying that the settings are different on the different heat recovery units.
2. Reset the outdoor unit and the power of the heat recovery unit so that the updated rotary switch settings are applied / saved to the system.
3. After Step No. 2 is complete, perform auto addressing again.
4. If the error occurs again even after auto addressing is complete, replace the corresponding heat recovery PCB.

- Error Code 206C only occurs on heat recovery units with a 485 modem (2A Series heat recovery units; 9,600 bps communication).
- Refer to the outdoor unit installation manual for heat recovery unit rotary switch address settings.

485 Modem on 2A Series Heat Recovery Units

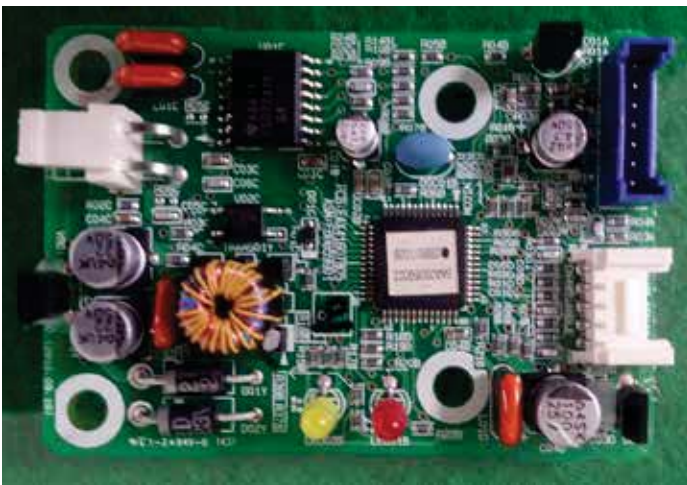

# ERROR CODES

## Error No. 237

**⚠ WARNING** Please refer to the Safety Precautions on pages 4-7 for more detail to prevent injury or death regarding the operation and service troubleshooting of the Multi V product.

Error No.	Description	Details	Causes
237	Communication error between outdoor unit PCB and indoor unit PCB.	Indoor unit communications PCB is not receiving signal from outdoor unit communications PCB for more than 3 minutes. Check RS-485 communications for issues.	<ol style="list-style-type: none"> <li>1. Check if the outdoor unit has been powered and if auto addressing has occurred.</li> <li>2. Check communication cable.</li> <li>3. Check outdoor unit communication module.</li> </ol>

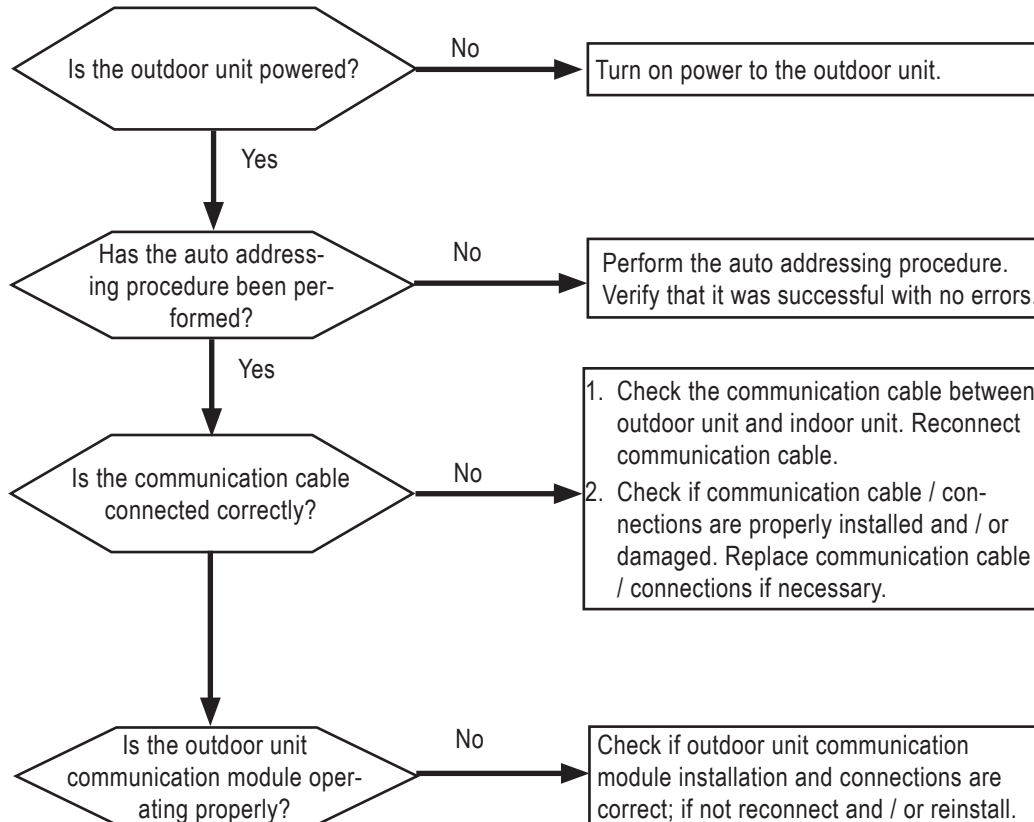

### Note:

See also Error Code No. 05: Indoor Unit PCB Communication Error between Outdoor Unit and Indoor Unit, and Error Code No. 238: Outdoor Unit PCB Communication Error Between Indoor Unit and Outdoor Unit.

**⚠ WARNING** Please refer to the Safety Precautions on pages 4-7 for more detail to prevent injury or death regarding the operation and service troubleshooting of the Multi V product.

Error No.	Description	Details	Causes
238	Communication error between outdoor unit PCB and indoor unit PCB.	Indoor unit communications PCB is not receiving signal from outdoor unit communications PCB for more than 3 minutes. Check outdoor unit PCB communications for issues.	<ol style="list-style-type: none"> <li>1. Check if the outdoor unit has been powered and if auto addressing has occurred.</li> <li>2. Check communication cable.</li> <li>3. Check outdoor unit PCB.</li> </ol>

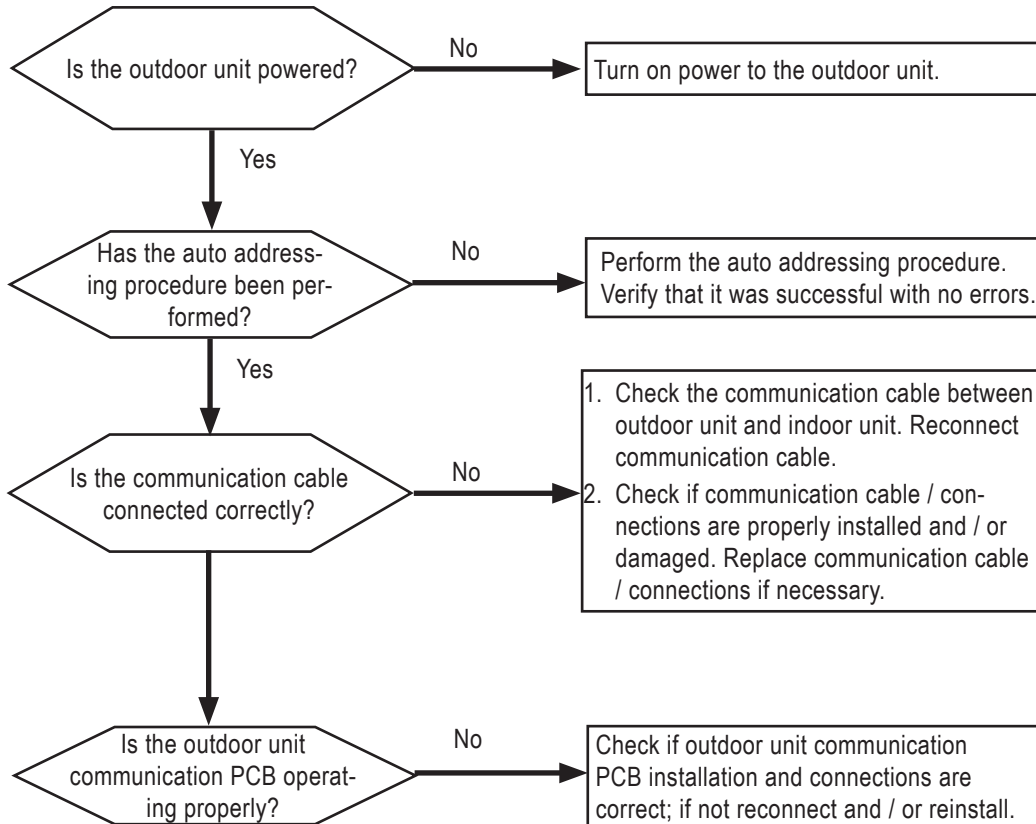

**Note:**

See also Error Code No. 05: Indoor Unit PCB Communication Error between Outdoor Unit and Indoor Unit, and Error Code No. 237: RS-485 Communication Error Between Indoor Unit and Outdoor Unit.

# ERROR CODES

## Error No. 242

**⚠ WARNING** Please refer to the Safety Precautions on pages 4-7 for more detail to prevent injury or death regarding the operation and service troubleshooting of the Multi V product.

Error No.	Description	Details	Causes
242	Network error.	Network error of central controller.	<ol style="list-style-type: none"> <li>1. RS-485 communication wiring defect.</li> <li>2. Communication defect between remote controller and indoor unit.</li> <li>3. RS-485 DIP switch setting error.</li> <li>4. Indoor unit addressing setting error on central controller.</li> </ol>
Master: 2421 Slave 1: 2422 Slave 2: 2423			

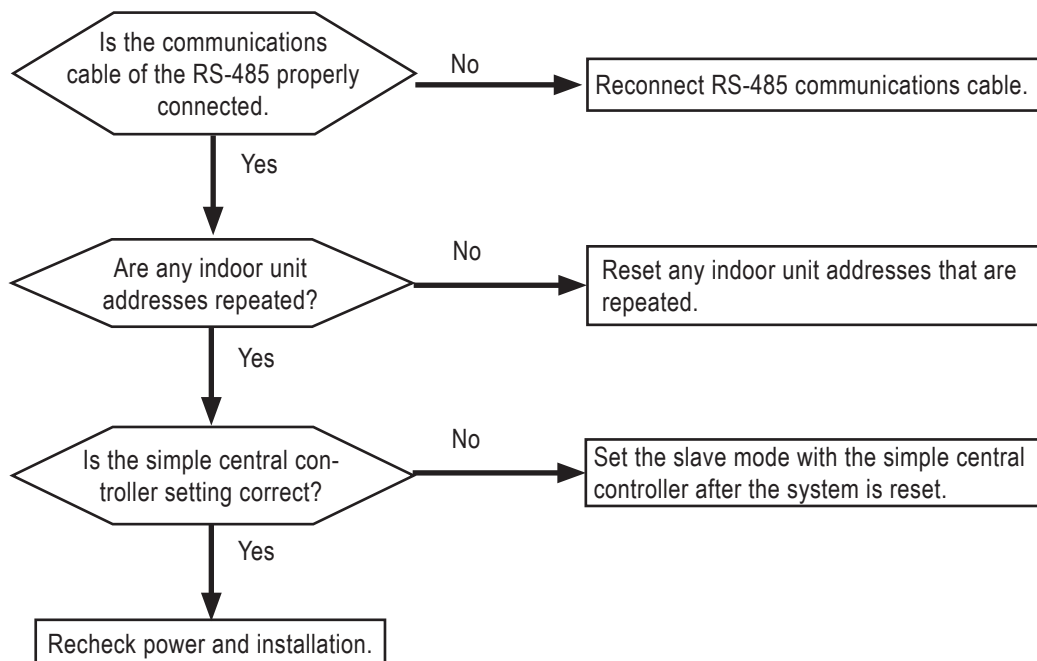

Communications LED Between the Network and the Outdoor Unit  
(The communications LED flashes on and off when communication is normal between the network and the outdoor unit.)

Incorrect RS-485 Communication Wiring

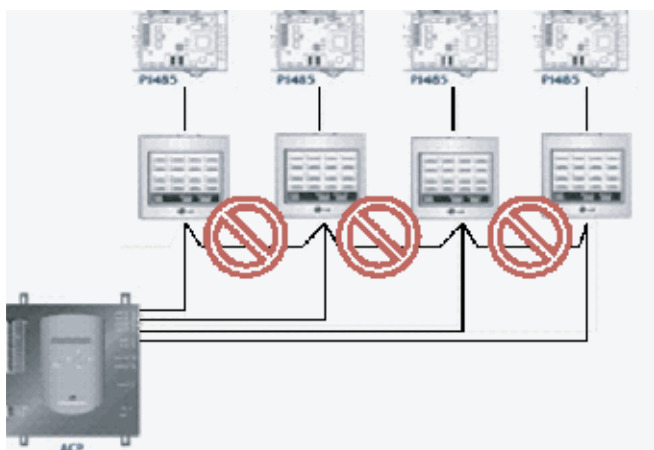

### Note:

Images here are representative of system components. Actual component appearance depends on model and system type.

---

---

## Replacing the Inverter PCB Heat Sink

If the inverter PCB is replaced at any time, the heat sink must be replaced.

### **⚠ WARNING**

*If there isn't any heat sink paste, or isn't a sufficient amount of heat sink paste, between the inverter PCB and the outdoor unit heat sink plate, the unit will overheat, causing a fire, physical injury, or death.*

### **Note:**

*If there isn't any heat sink paste, or isn't a sufficient amount of heat sink paste, between the inverter PCB and the outdoor unit heat sink plate, the unit will overheat and damage the PCB and outdoor unit.*

1. Remove inverter PCB by detaching its screws using a JIS screwdriver.

### **Note:**

*Only use a JIS screwdriver. A standard Phillips screwdriver will damage / strip the inverter PCB screw heads.*

2. Wipe off any existing heat sink paste material from the inverter PCB heat sink plate, as well as from the outdoor unit heat sink plate.  
Gently scrape off as much heat sink paste material as possible, taking care not to damage the back of the inverter PCB or the outdoor unit heat sink plate.
3. Evenly apply a coating of silicone-based electronic heat sink paste to the inverter PCB heat plate. Verify all applicable areas of the PCB heat plate are completely covered. Ⓞ Do not let foreign matter settle onto the heat sink paste.
4. Reinstall the inverter PCB by reattaching its screws with a JIS screwdriver. Tighten the screws, but Ⓞ do not overtighten.

# CHECKING INPUT VOLTAGE IN CASE OF POWER ON



**WARNING** Please refer to the Safety Precautions on pages 4-7 for more detail to prevent injury or death regarding the operation and service troubleshooting of the Multi V product.

## Checking Input Voltage (Three Phase / Three Wire)

Figure 79: Checking Input Voltage.

Figure 80: Multi-Meter.

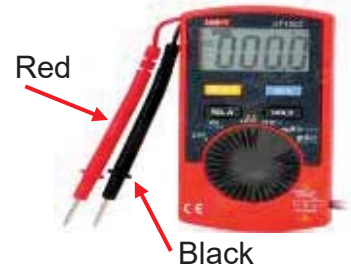
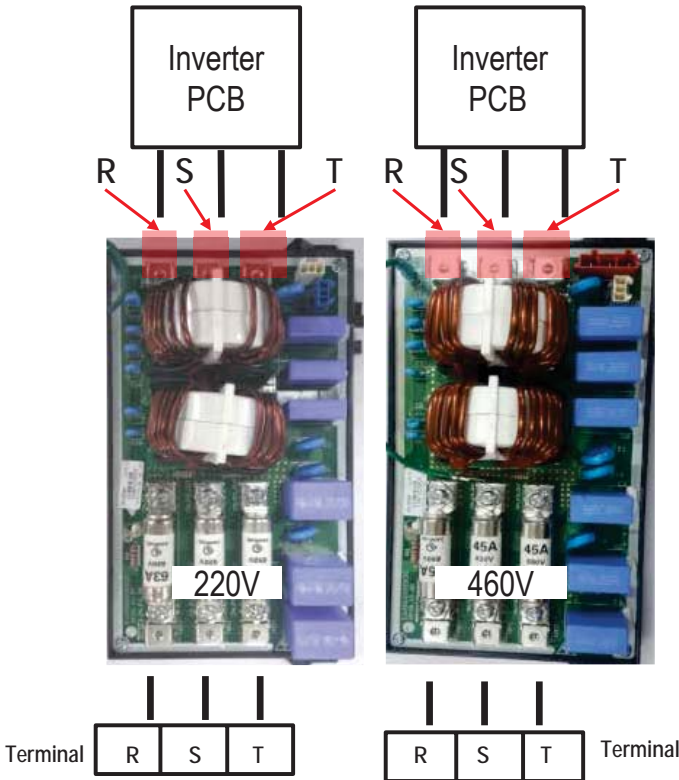

Table 90: Input Voltage Measurements.

Check	Mode	Multi-Meter		Measured Value	
		Black	Red	Normal	Abnormal
Input Voltage (3-Phase/3-Wire 220V)	AC	R	S	220V±15%	Not Normal
		R	T		
		S	T		
Input Voltage (3-Phase /3-Wire 460V)	AC	R	S	460V±15%	
		R	T		
		S	T		

**⚠ WARNING** Please refer to the Safety Precautions on pages 4-7 for more detail to prevent injury or death regarding the operation and service troubleshooting of the Multi V product.

## Checking Main PCB DC Voltage

Figure 81: Checking Main PCB DC Voltage (SMPS Voltage).

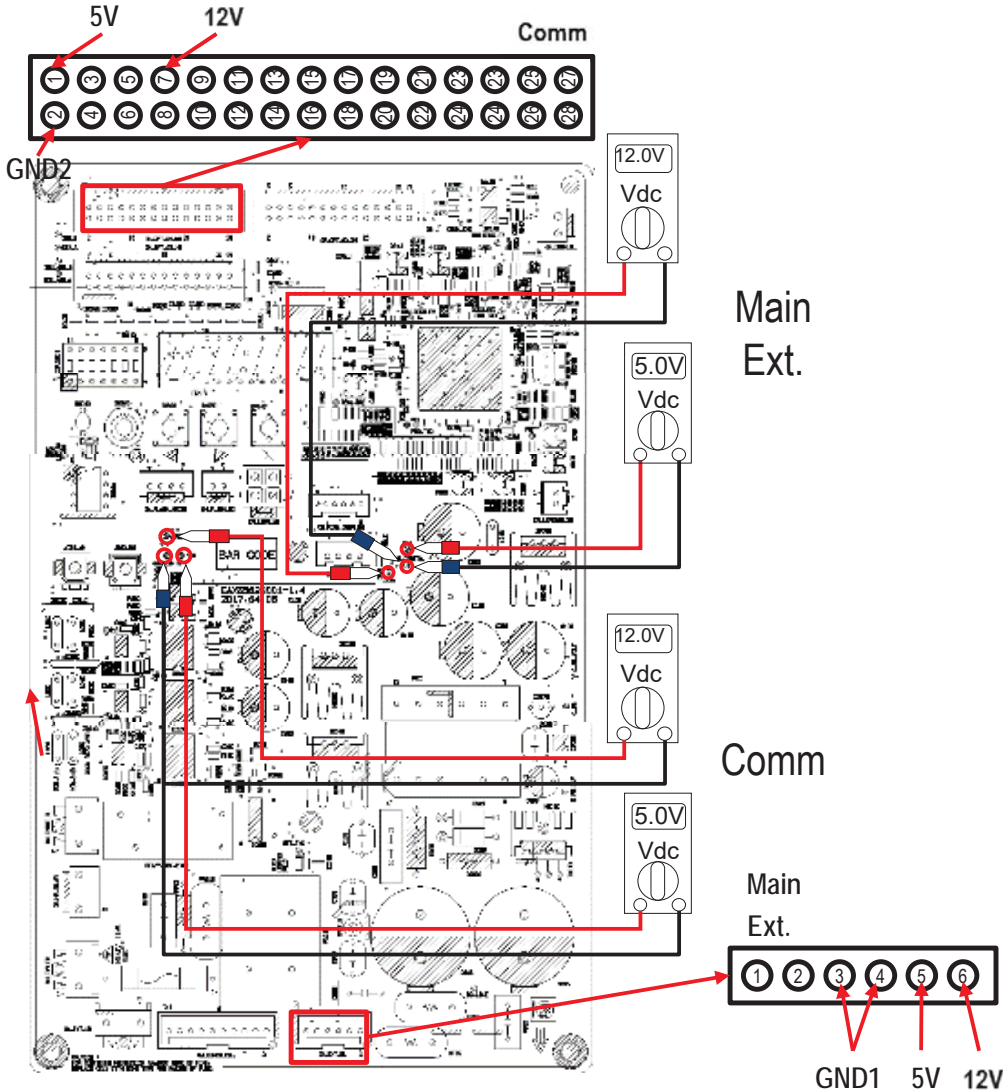
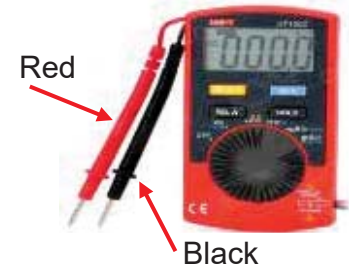

Figure 82: Multi-Meter (Note the Probe Color).



Error Codes

Table 91: Main PCB DC Voltage (SMPS Voltage) Measurements.

Check	Mode	Multi-Meter		Measured Value	
		Black	Red	Normal	Abnormal
Main Ext.	5V	GND2	5V	4.5V~5.5V	4V ↓
	12V		12V	11.5V~12.5V	11V ↓
Comm.	5V	GND3	5V	4.5V~5.5V	4V ↓
	12V		12V	11.5V~12.5V	11V ↓

**⚠ WARNING**

Use caution when measuring the voltage; GND is separated. There is risk of electric shock, and physical injury or death.

# CHECKING CONVERTER DC LINK VOLTAGE IN CASE OF COMPRESSOR OPERATING

**MULTI V 5**

**⚠ WARNING** Please refer to the Safety Precautions on pages 4-7 for more detail to prevent injury or death regarding the operation and service troubleshooting of the Multi V product.

Figure 83: Checking Converter DC Link Voltage.

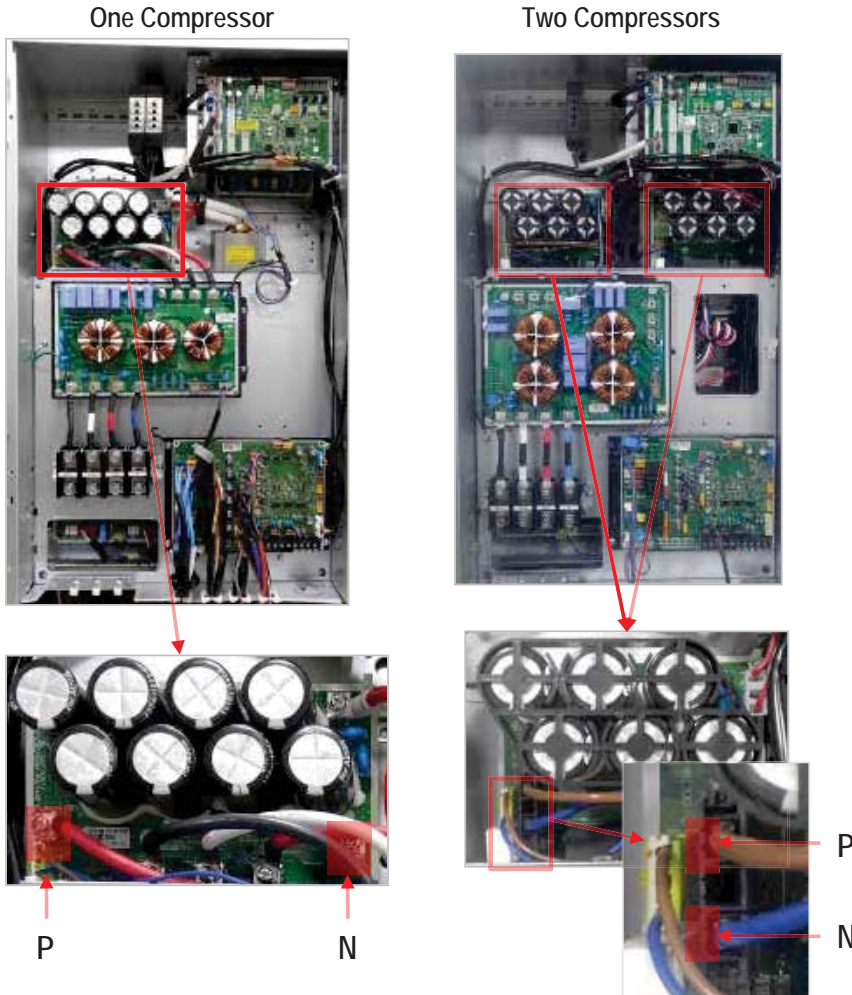
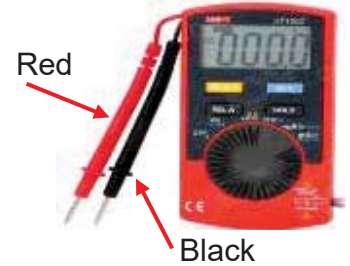

Figure 84: Multi-Meter (Note the Probe Color).



MULTI V 5 Outdoor Unit Service Manual

Table 92: Converter DC Link Voltage Measurements.

Check		Mode	Multi-Meter		Measured Value	
			Black	Red	Normal	Abnormal
DC Link Voltage	3-Phase / 3-Wire / 220V	DC	N	P	310V±20%	140V↓, 420V↑
	3-Phase / 3-Wire / 460V		N	P	650V±20%	300V↓, 780V↑

**COMM. (DC VOLTAGE) IN CASE OF POWER ON**



**WARNING** Please refer to the Safety Precautions on pages 4-7 for more detail to prevent injury or death regarding the operation and service troubleshooting of the Multi V product.

Figure 85: Checking ODU to ODU Communications (DC Voltage) (Slave Unit).

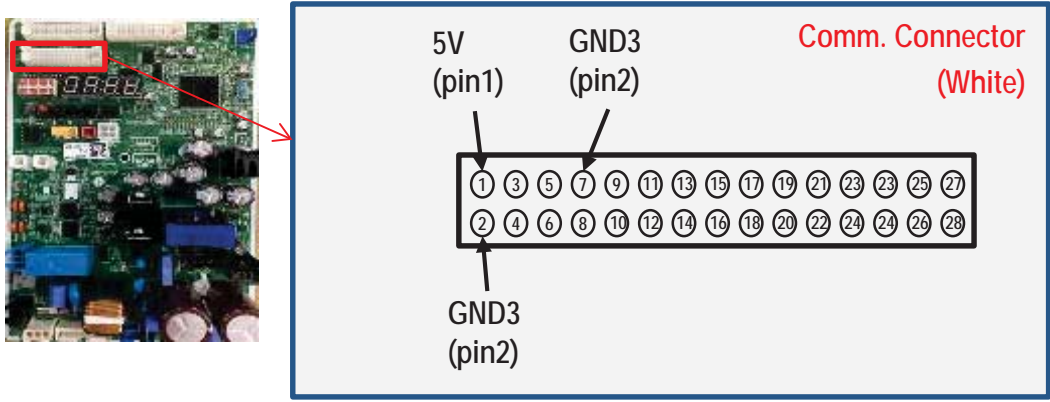

Figure 86: Multi-Meter (Note the Probe Color).

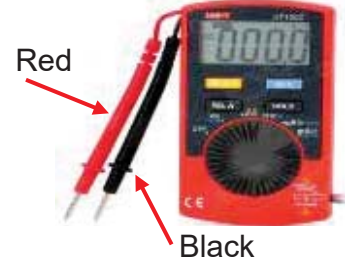

Table 93: ODU to ODU Communications (DC Voltage) Measurements.

Check	Mode	Multi-Meter		Measured Value	
		Black	Red	Normal	Abnormal
Main (DC-Comm.)	DC	GND3 (pin2)	5V (pin1)	4.5V~5.5V	4V↓

# CHECKING INVERTER PCB IN CASE OF POWER OFF

**⚠ WARNING** Please refer to the Safety Precautions on pages 4-7 for more detail to prevent injury or death regarding the operation and service troubleshooting of the Multi V product.

Figure 87: Checking Inverter PCB.

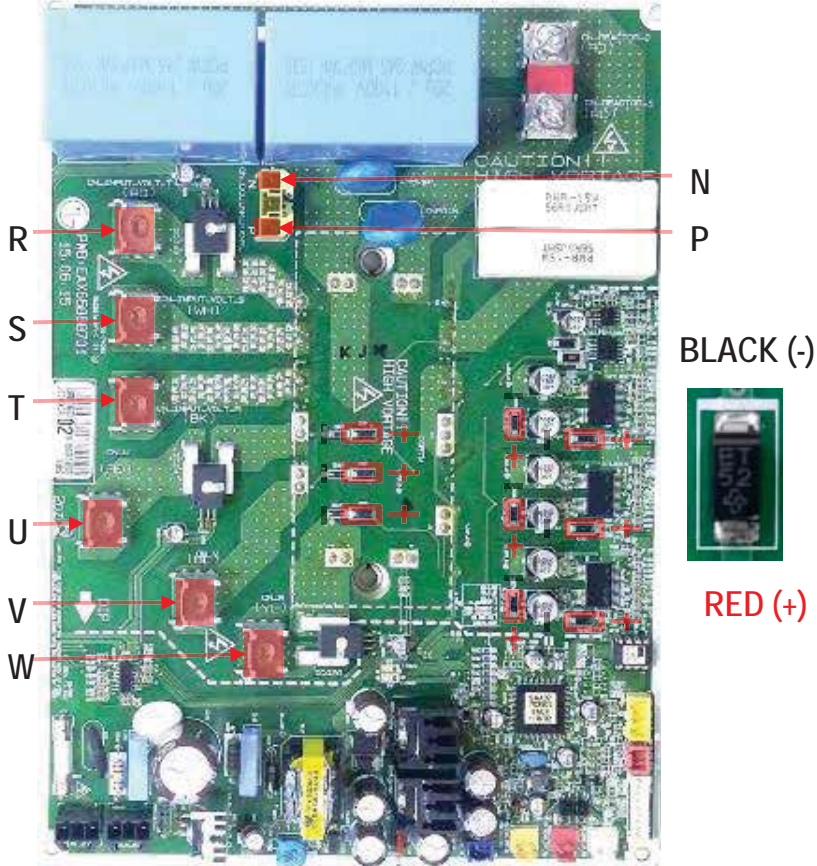

Figure 88: Multi-Meter.

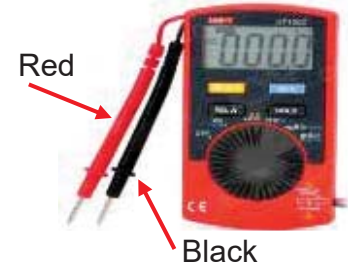

Table 94: Inverter PCB Measurements.

Check	Mode	Multi-Meter		Measured Value		
		Black	Red	Normal	Abnormal	
5V Part Resistance	$\Omega$	GND	5V	$1k\Omega \uparrow$	$1k\Omega \downarrow \sim 0\Omega$	
15V Part Resistance	$\Omega$	GND	15V	$10k\Omega \uparrow$	$10k\Omega \downarrow \sim 0\Omega$	
IGBTM		P-(UVW)	U	0.38V ~ 0.7 V	Not normal	
			V			
			W			
		U	N			
						V
						W
		P-(RST)	R			
			S			
			T			
R	N					
S						
T						
Diode (9EA)		-	+	0.38 ~ 0.7 V	Not normal	

Figure 89: Power Wiring Diagram (Three phase 220V).

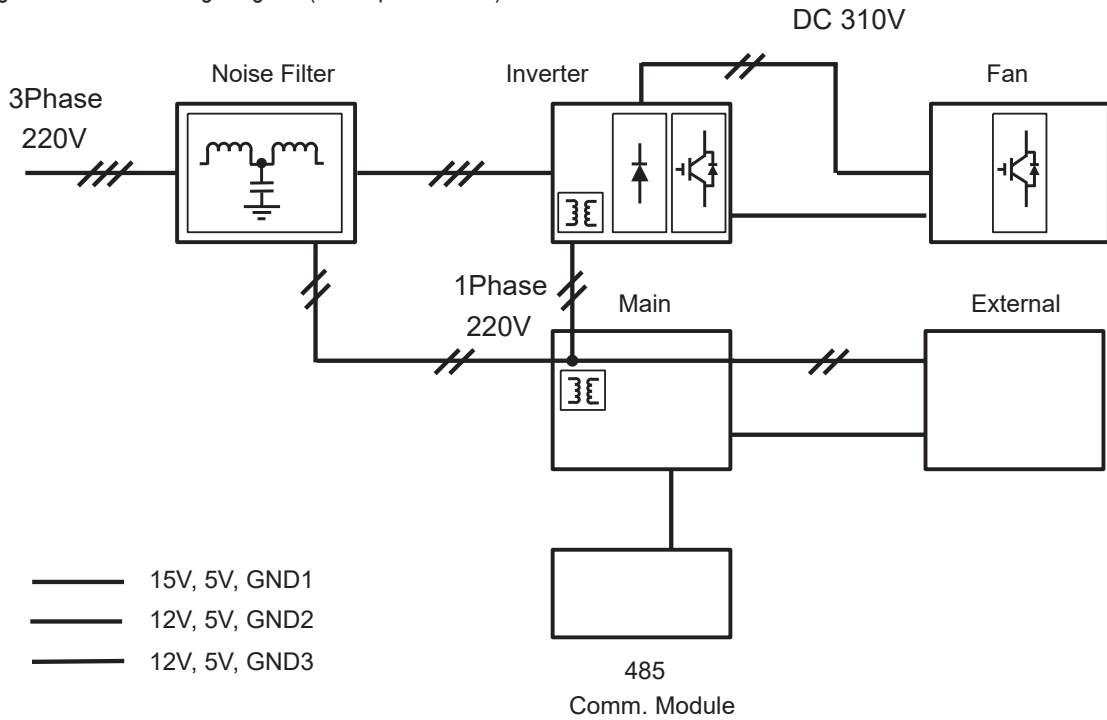
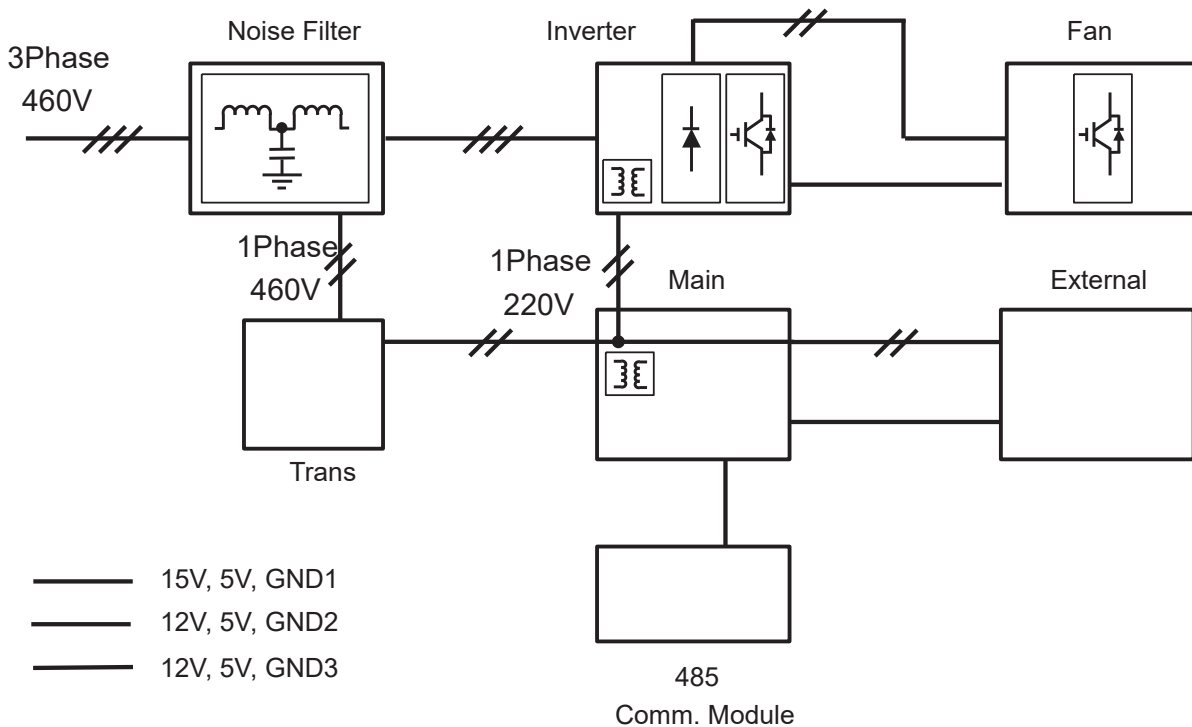

Figure 90: Power Wiring Diagram (Three phase 460V).



Error Codes

UX B Outdoor Unit Control Box (Front View)



UX A Outdoor Unit Control Box (Back View)

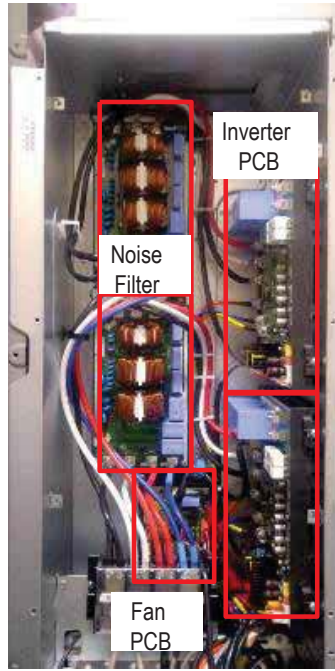

UX A Outdoor Unit Control Box

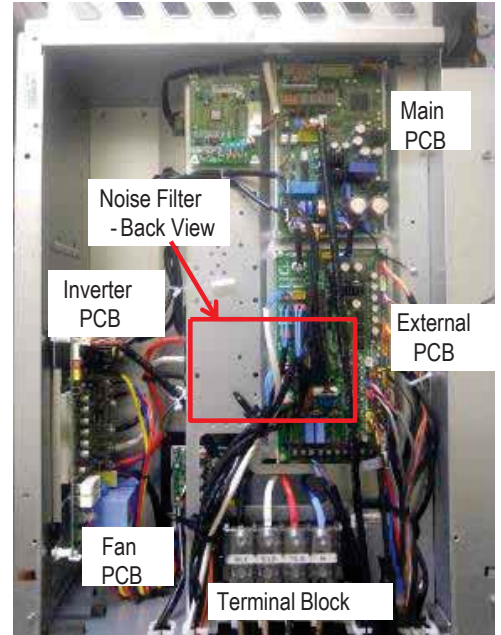

Main PCB



External PCB



Inverter PCB



Noise Filter



Fan PCB



IDU-ODU Communication PCBA

**Main PCB**

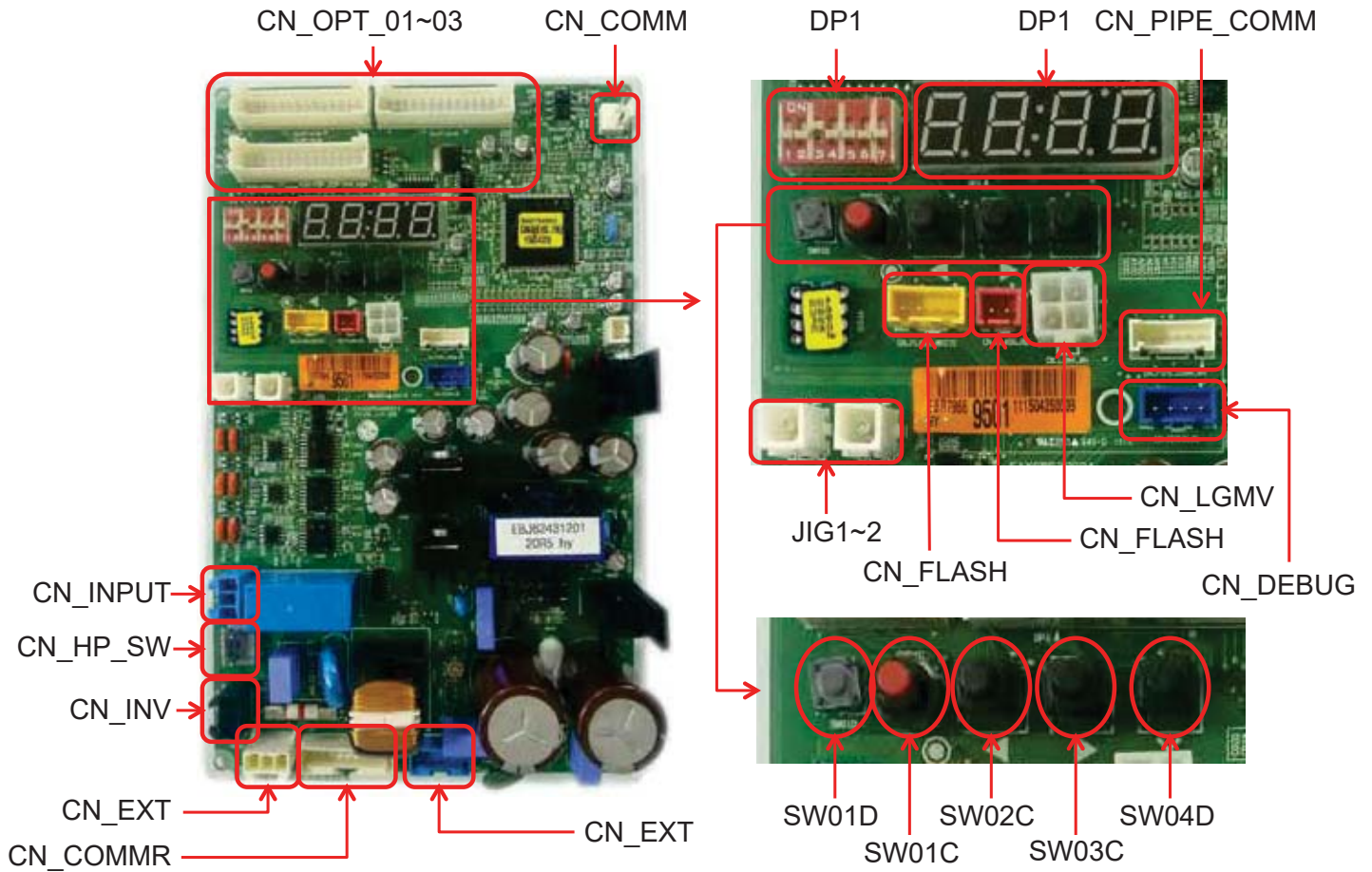

Parts

**Note:**

Actual component appearances may differ depending on manufacturing date, model, system type, etc.

### External PCB

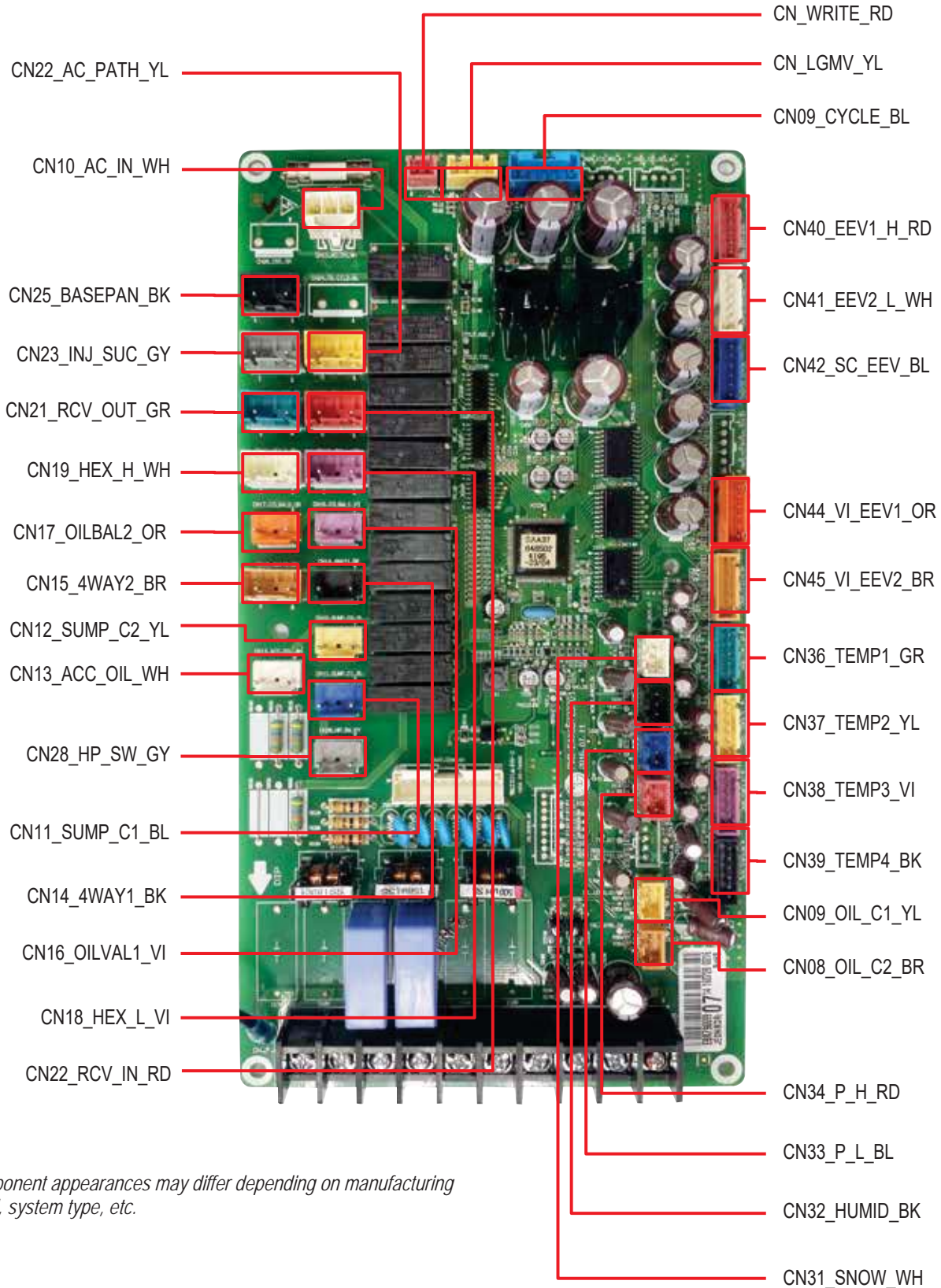

**Note:**

Actual component appearances may differ depending on manufacturing date, model, system type, etc.

**Inverter PCB for 208-230V Outdoor Units (17kW)**

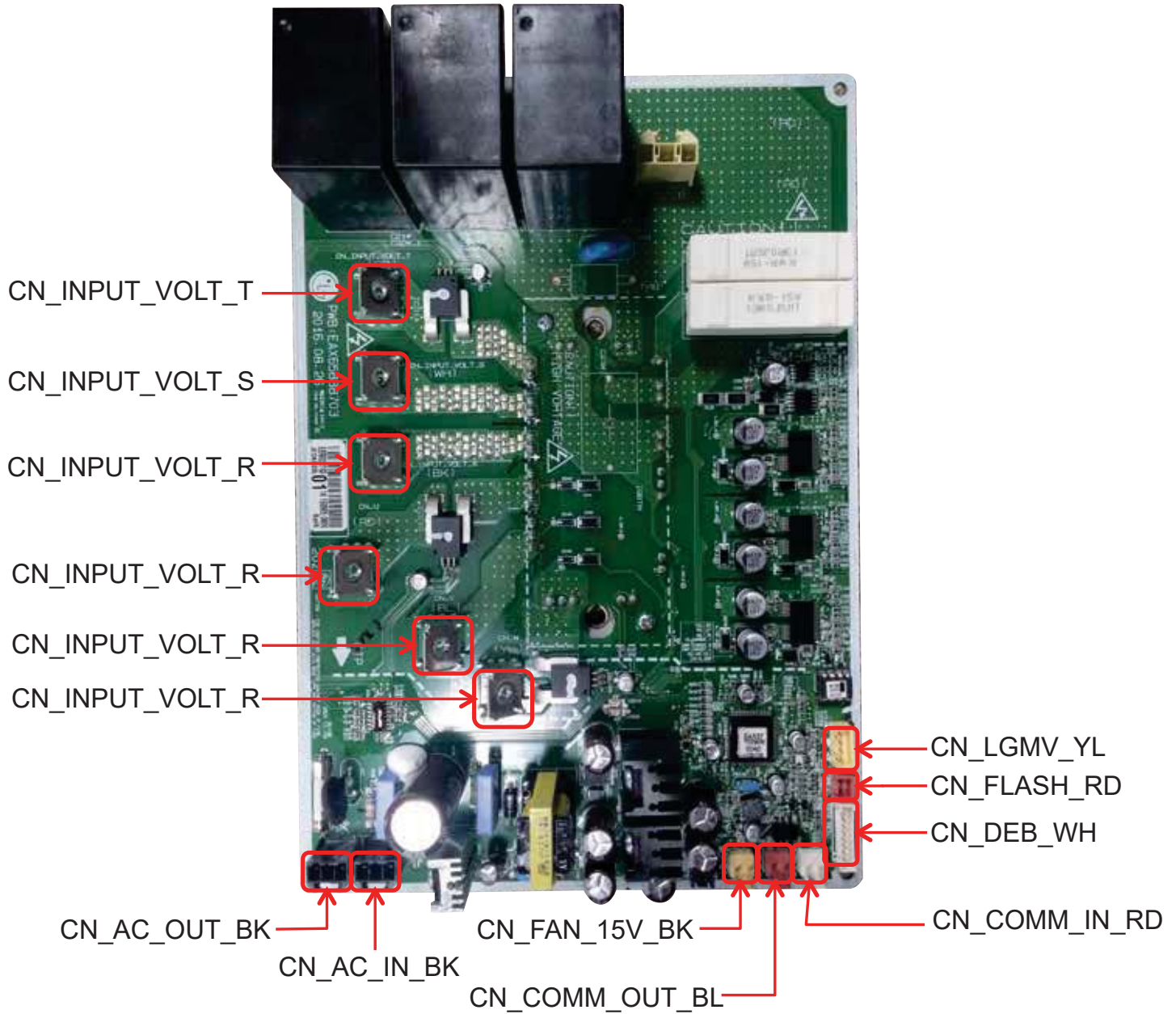

**Note:**

Actual component appearances may differ depending on manufacturing date, model, system type, etc.

# OUTDOOR UNIT PARTS

**MULTI V 5**

PCBs

## Inverter PCB for 208-230V Outdoor Units (12kW)

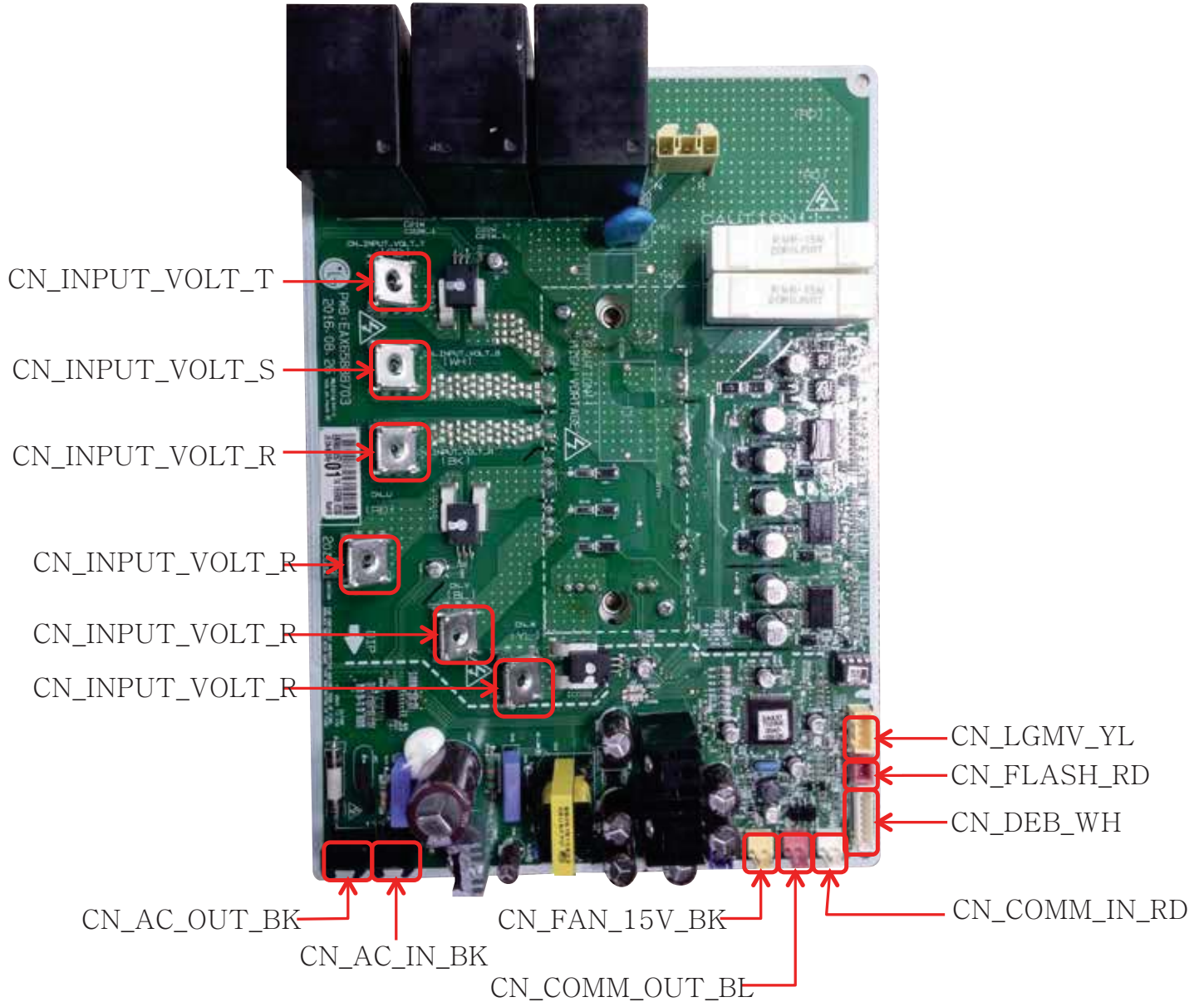

### Note:

Actual component appearances may differ depending on manufacturing date, model, system type, etc.

Inverter PCB for 460V Outdoor Units (17kW)

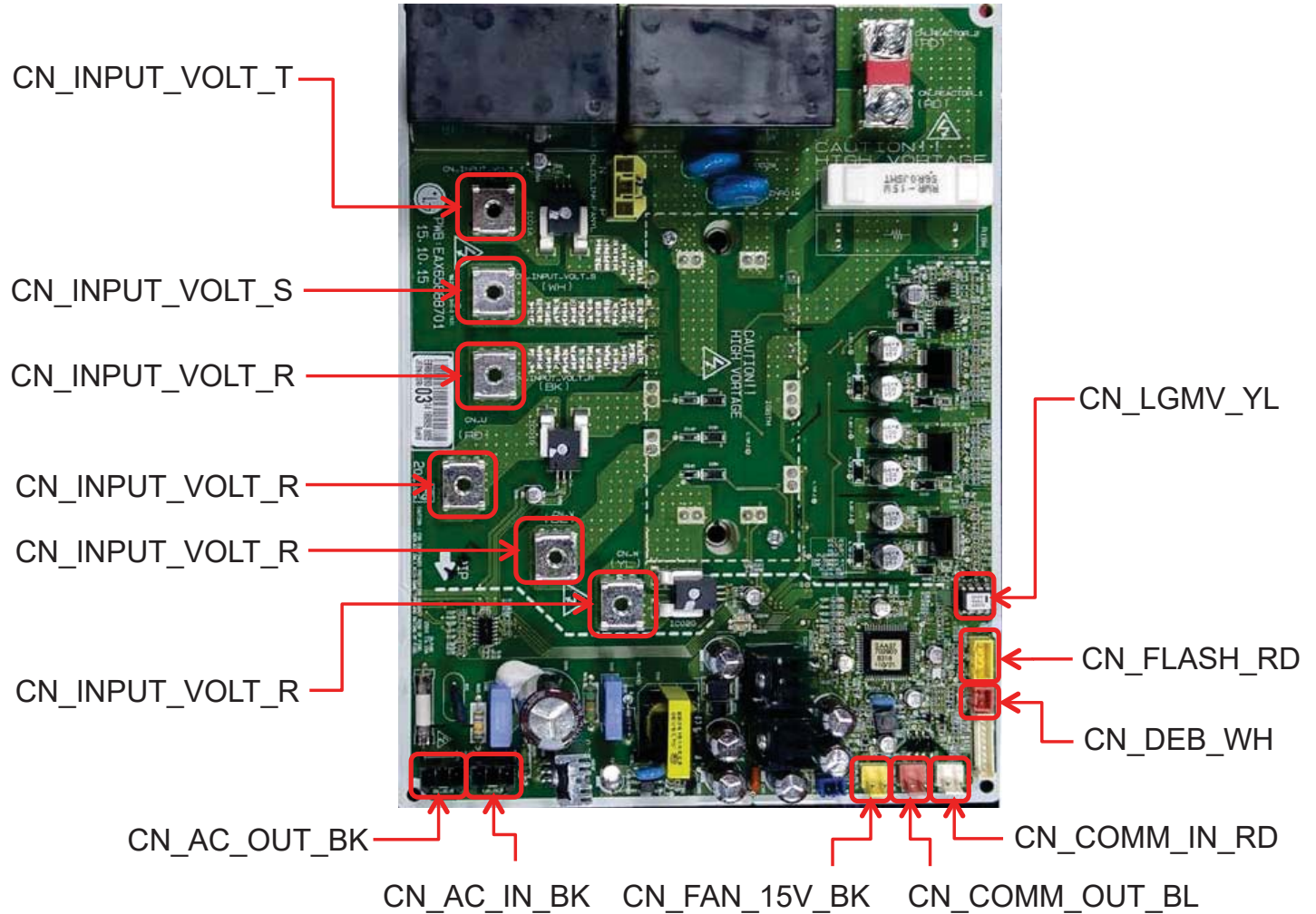

Parts

**Note:**

Actual component appearances may differ depending on manufacturing date, model, system type, etc.

# OUTDOOR UNIT PARTS

MULTI V 5

PCBs

## Inverter PCB for 460V Outdoor Units (12kW)

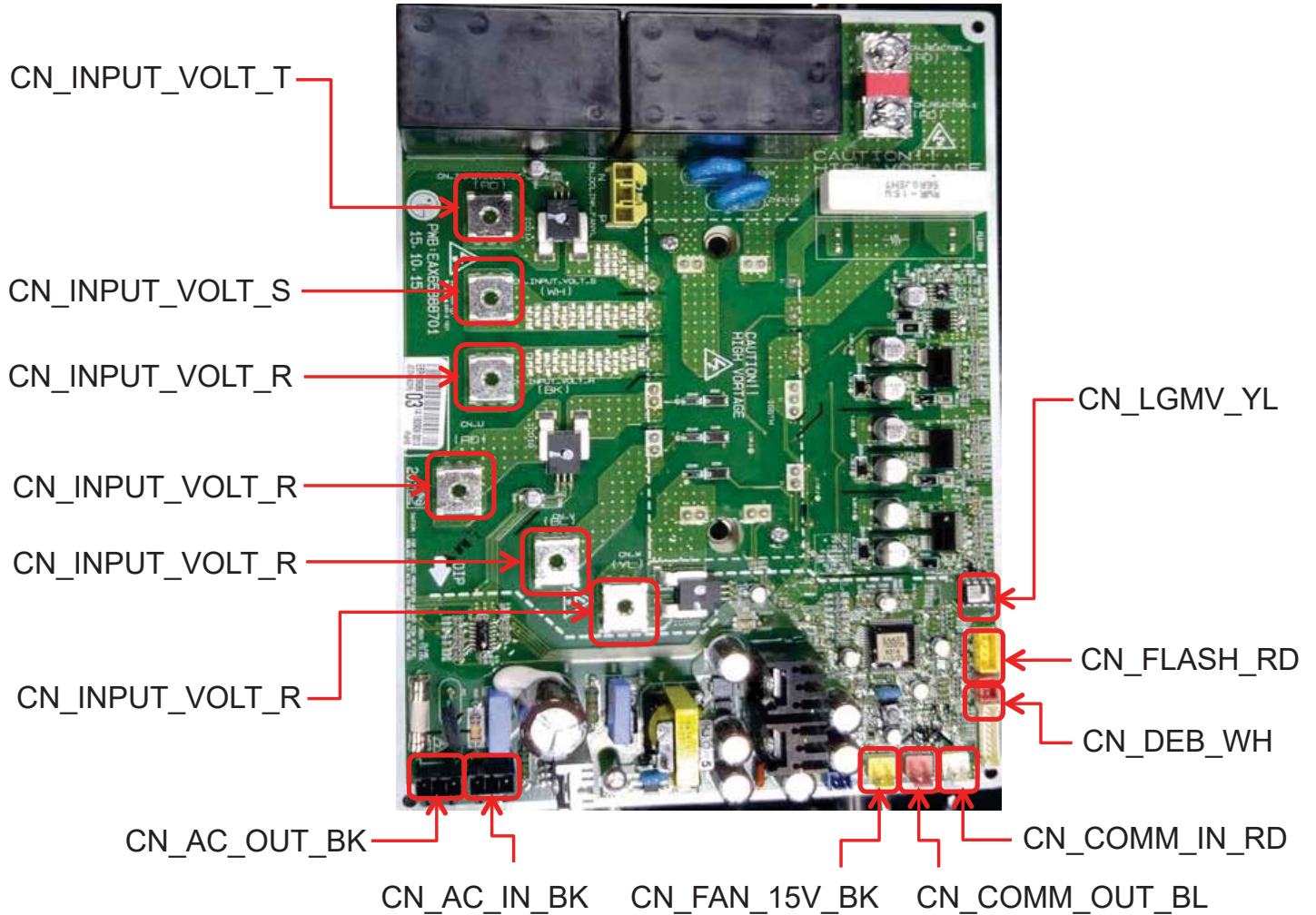

### Note:

Actual component appearances may differ depending on manufacturing date, model, system type, etc.

Fan PCB

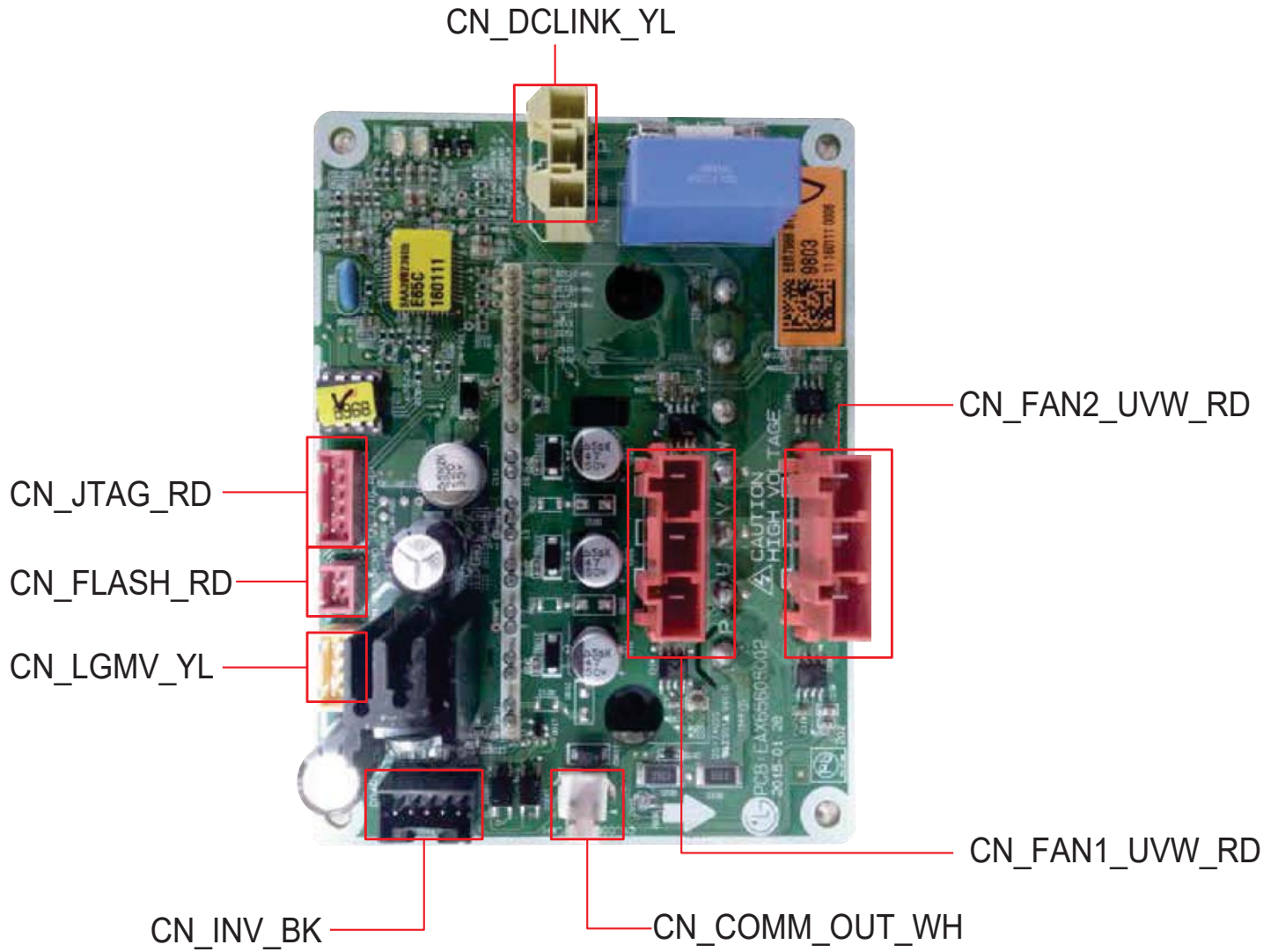

Parts

**Note:**

Actual component appearances may differ depending on manufacturing date, model, system type, etc.

# OUTDOOR UNIT PARTS

**MULTI V™ 5**

PCB

**Noise Filter PCB for 208-230V  
Outdoor Units (17kW)**

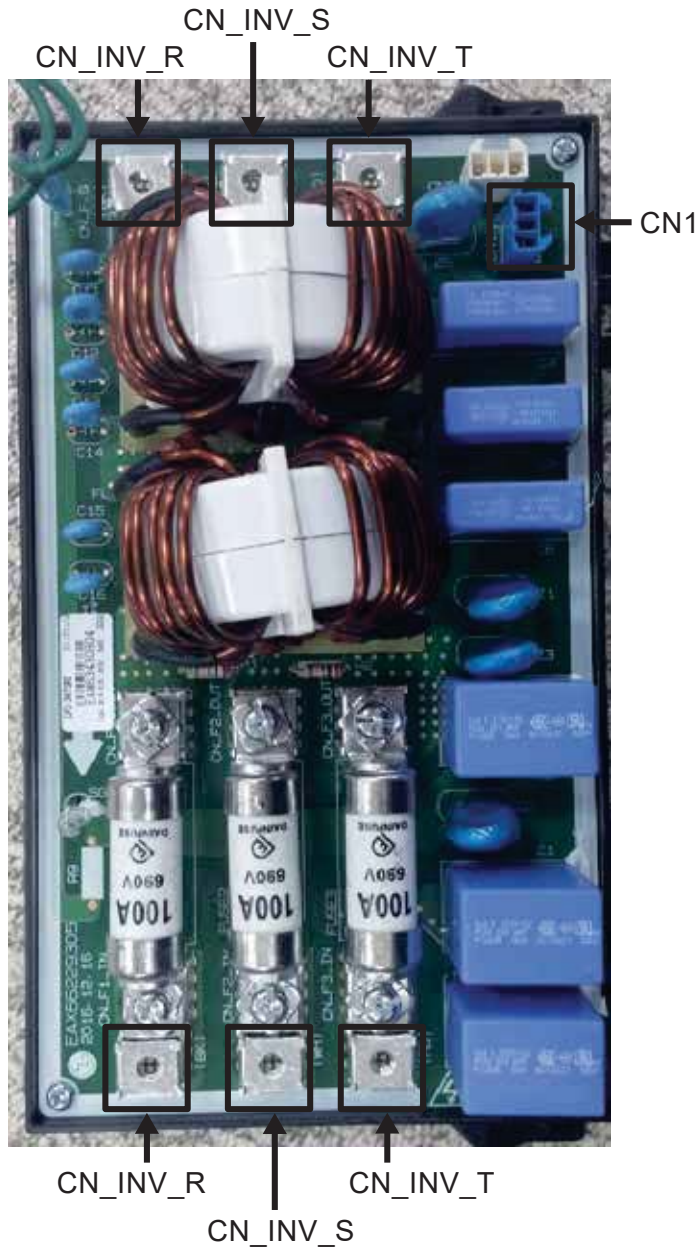

**Noise Filter PCB for 208-230V  
Outdoor Units (12kW)**



**Note:**

Actual component appearances may differ depending on manufacturing date, model, system type, etc.

MULTI V 5 Outdoor Unit Service Manual

**Noise Filter PCB for 460V Outdoor Units (17kW)**

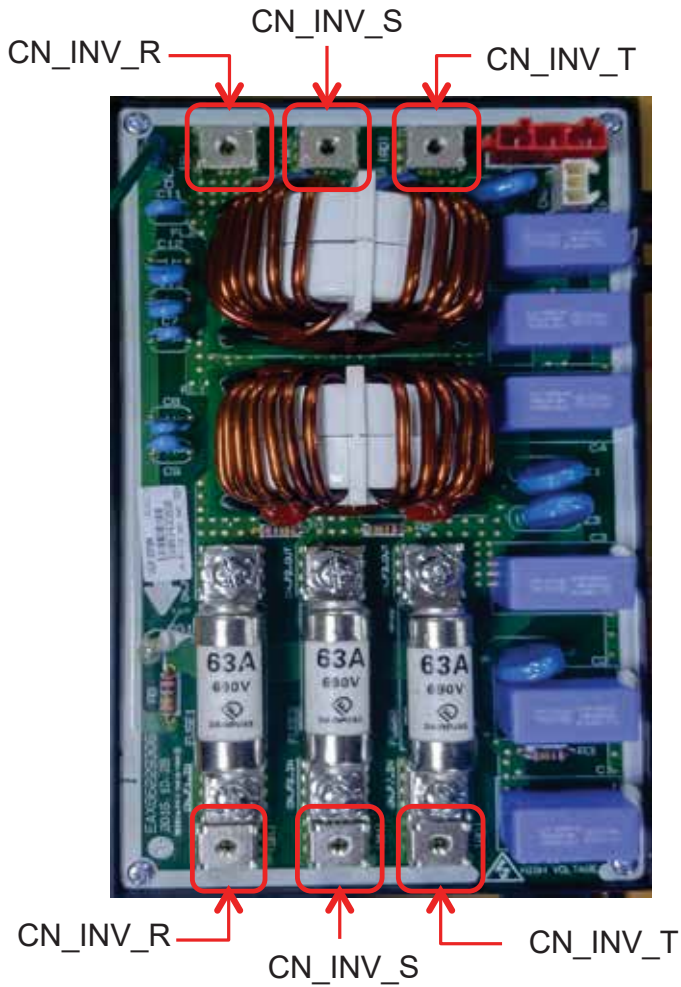

**Noise Filter PCB for 460V Outdoor Units (12kW)**

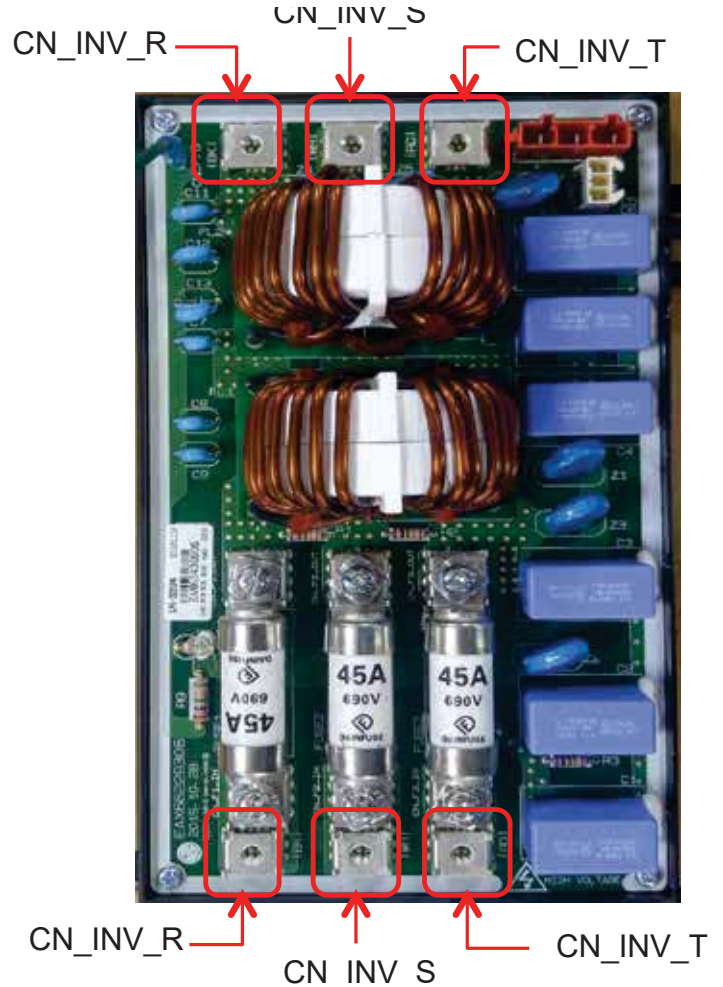

Parts

**Note:**

Actual component appearances may differ depending on manufacturing date, model, system type, etc.

# OUTDOOR UNIT PARTS

**MULTI V 5**

PCBs - Expanded Internal View

## PCBs - Expanded Internal View for 6-Ton (Small Frame) Outdoor Units

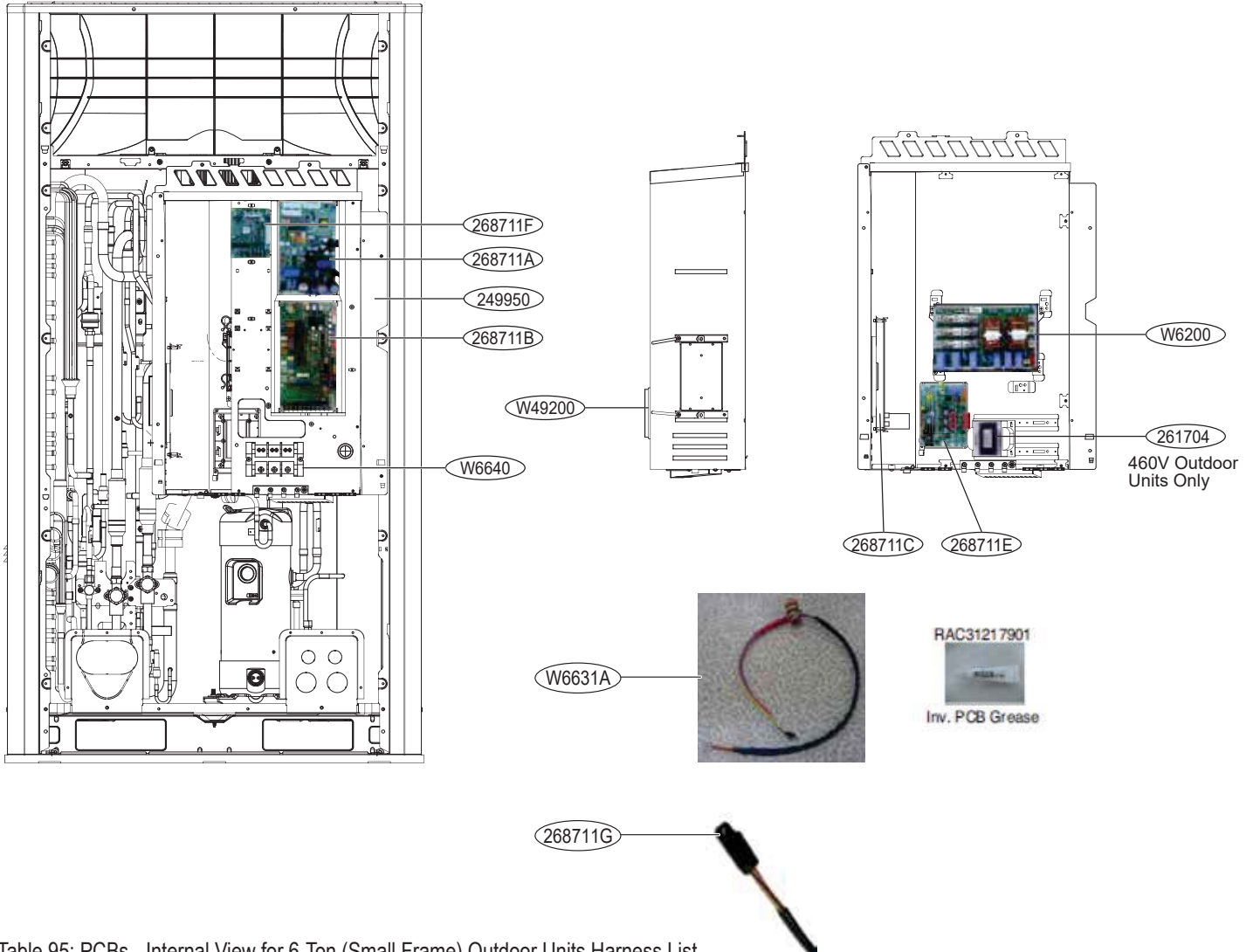

Table 95: PCBs - Internal View for 6-Ton (Small Frame) Outdoor Units Harness List.

Type	Part No.	Description	Color
Multiple Harness	W6631A	Inverter PCB to Compressor Power Wiring	-
Single Harness	W6631C	Main PCB to External PCB Communication Cable	White - White
Single Harness	W6631D	Fan PCB to Inverter PCB DC Link	Yellow - Yellow
Single Harness	W6631E	Main PCB to External PCB Communication Cable	Blue - Blue
Single Harness	W6631F	Main PCB to External PCB Power Wiring	White - White
Single Harness	W6631G	Main PCB to Inverter PCB Communication Cable	White to Blue
Single Harness	W6631H (208-230V Outdoor Units Only)	Noise Filter PCB to Main PCB Power Wiring	Black - Black
Single Harness	W6631J	Main PCB to Inverter PCB Power Wiring	Black - Black
Multiple Harness	W6631K	Fan PCB to Inverter PCB Communication Cable	Black - Red - Yellow
Single Harness	W6631L	Indoor Unit Communication PCB to Main PCB Communication Cable	White - White

### Note:

Actual component appearances may differ depending on manufacturing date, model, system type, etc.

**PCBs - Expanded Internal View for 8- and 10-Ton (Large Frame) Outdoor Units**

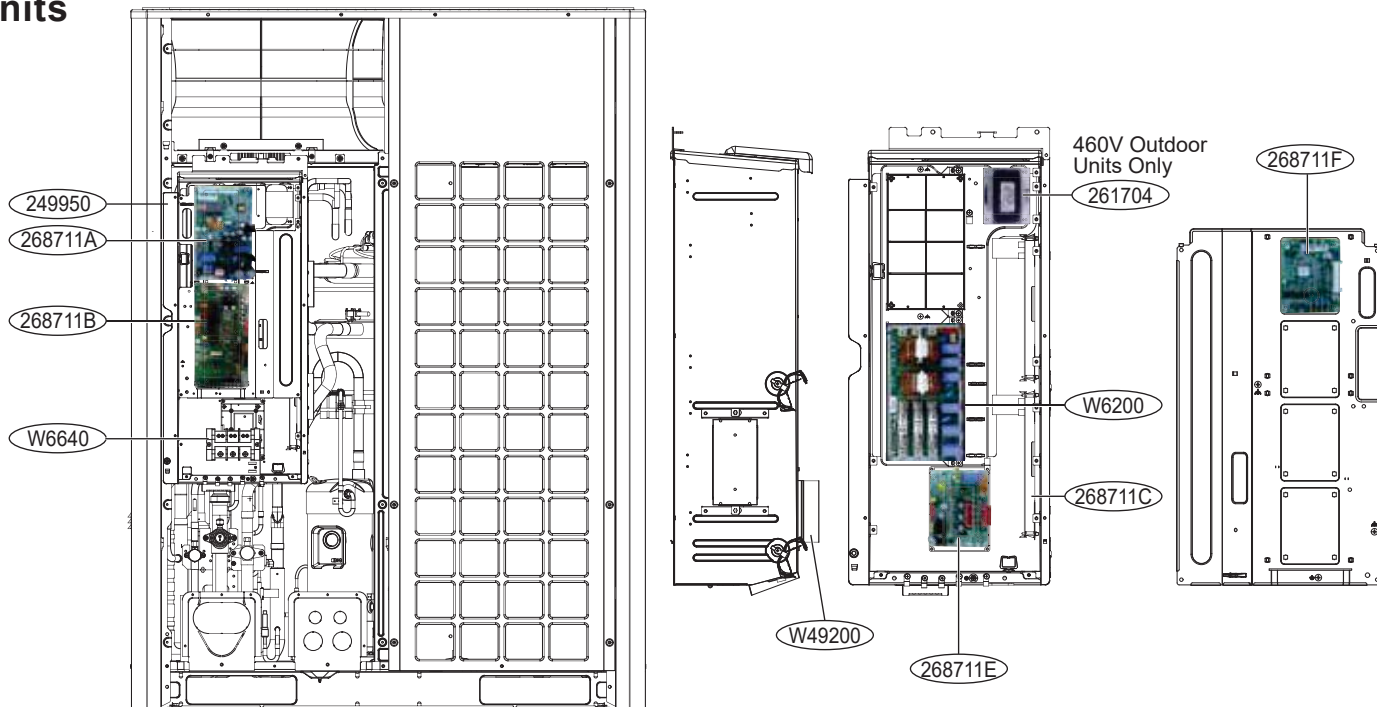

W6631A



RAC31217901



Inverter PCB Grease

268711G



Table 96: PCBs - Internal View for 8- and 10-Ton (Large Frame) Outdoor Units Harness List.

Type	Part No.	Description	Color
Multiple Harness	W6631A	Inverter PCB to Compressor Power Wiring	-
Single Harness	W6631C	Main PCB to External PCB Communication Cable	White - White
Single Harness	W6631D	Fan PCB to Inverter PCB DC Link	Yellow - Yellow
Single Harness	W6631E	Main PCB to External PCB Communication Cable	Blue - Blue
Single Harness	W6631F	Main PCB to External PCB Power Wiring	White - White
Single Harness	W6631G	Main PCB to Inverter PCB Communication Cable	White to Blue
Single Harness	W6631H (208-230V Outdoor Units Only)	Noise Filter PCB to Main PCB Power Wiring	Black - Black
Single Harness	W6631J	Main PCB to Inverter PCB Power Wiring	Black - Black
Multiple Harness	W6631K	Fan PCB to Inverter PCB Communication Cable	Black - Red - Yellow
Single Harness	W6631L	Indoor Unit Communication PCB to Main PCB Communication Cable	White - White

**Note:**

Actual component appearances may differ depending on manufacturing date, model, system type, etc.

# OUTDOOR UNIT PARTS

**MULTI V 5**

## PCBs - Expanded Internal View

### PCBs - Expanded Internal View for 12- to 20-Ton (Large Frame) Outdoor Units

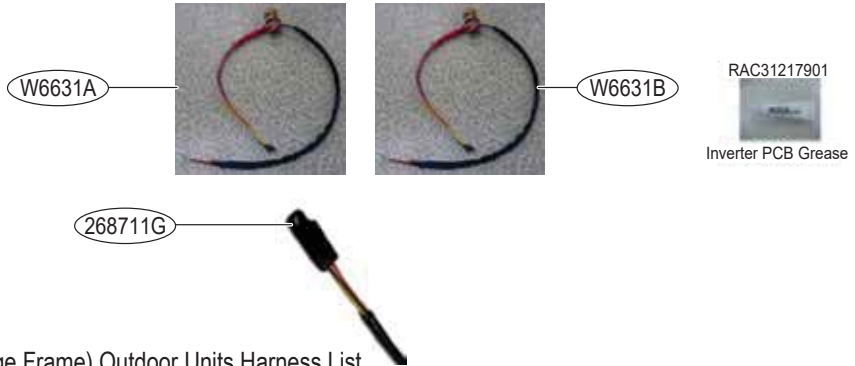
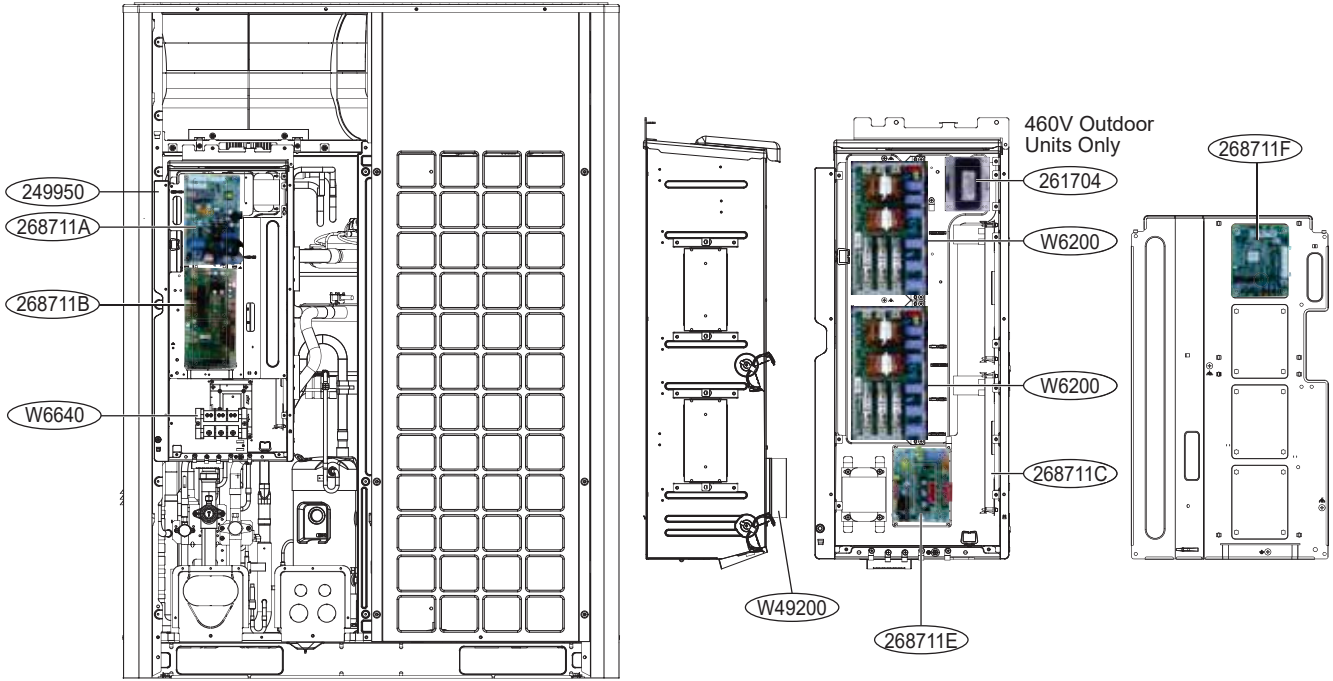

Table 97: PCBs - Internal View for 12- to 20-Ton (Large Frame) Outdoor Units Harness List.

Type	Part No.	Description	Color
Multiple Harness	W6631A	Inverter 1 PCB to Compressor 1 Power Wiring	-
Multiple Harness	W6631B	Inverter 2 PCB to Compressor 2 Power Wiring	-
Single Harness	W6631C	Main PCB to External PCB Communication Cable	White - White
Single Harness	W6631D	Fan PCB to Inverter PCB DC Link	Yellow - Yellow
Single Harness	W6631E	Main PCB to External PCB Communication Cable	Blue - Blue
Single Harness	W6631F	Main PCB to External PCB Power Wiring	White - White
Single Harness	W6631G	Main PCB to Inverter PCB Communication Cable	White to Blue
Single Harness	W6631H (208-230V Outdoor Units Only)	Noise Filter PCB to Main PCB Power Wiring	Black - Black
Single Harness	W6631J	Main PCB to Inverter PCB Power Wiring	Black - Black
Multiple Harness	W6631K	Fan PCB to Inverter PCB Communication Cable	Black - Red - Yellow
Single Harness	W6631L	Indoor Unit Communication PCB to Main PCB Communication Cable	White - White
Single Harness	W6631M	Inverter 1 PCB to Inverter 2 PCB Power Wiring	Black - Black
Single Harness	W6631N	Inverter 1 PCB to Inverter 2 PCB Communication Cable	Red - White

### Note:

Actual component appearances may differ depending on manufacturing date, model, system type, etc.



# OUTDOOR UNIT PARTS

MULTI V 5™

Expanded Frame View

## Expanded Frame View for 8- and 10-Ton (Large Frame) Outdoor Units

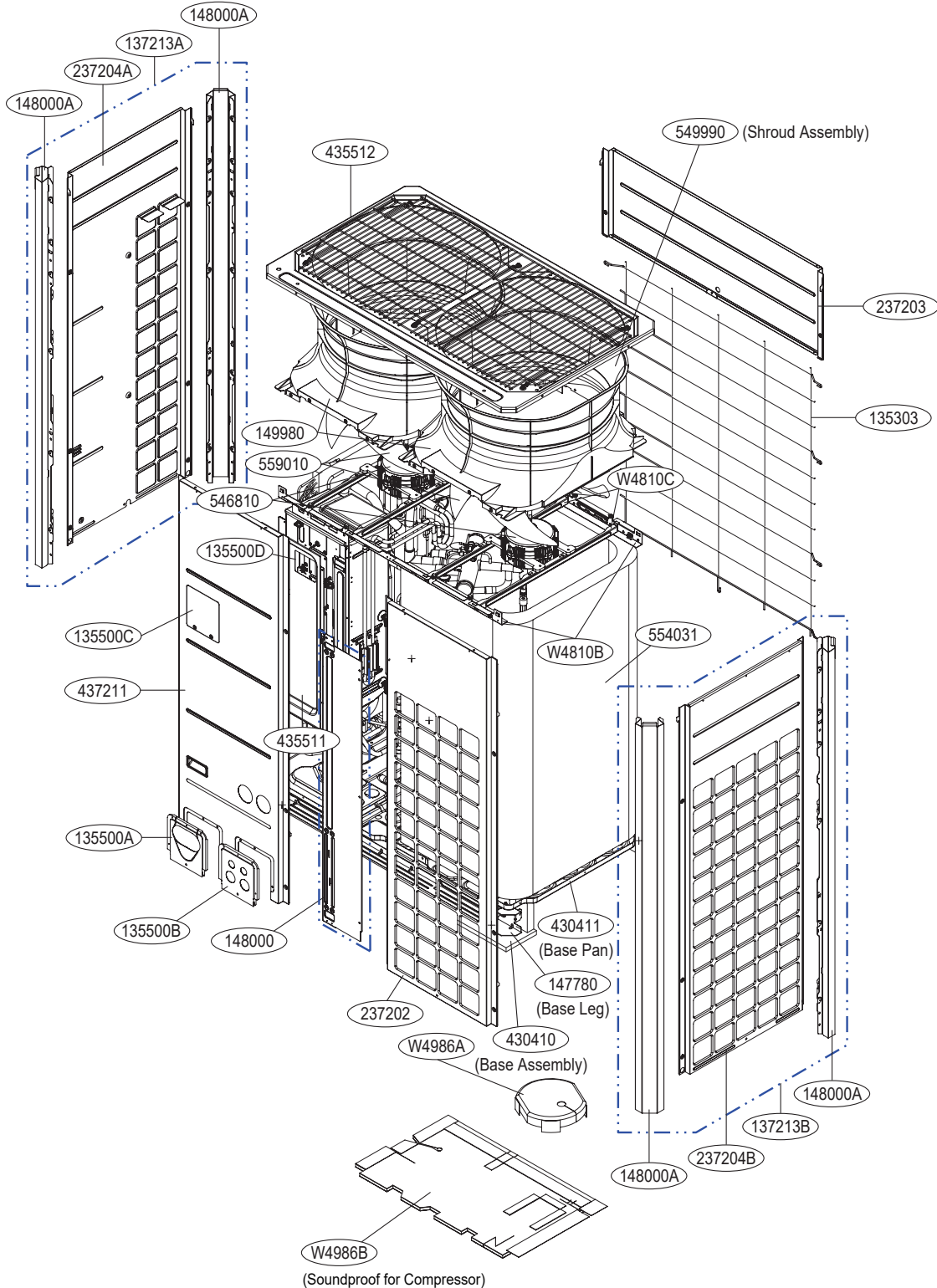

### Note:

Actual component appearances may differ depending on manufacturing date, model, system type, etc.

**Expanded Frame View for 12- to 20-Ton (Large Frame) Outdoor Units**

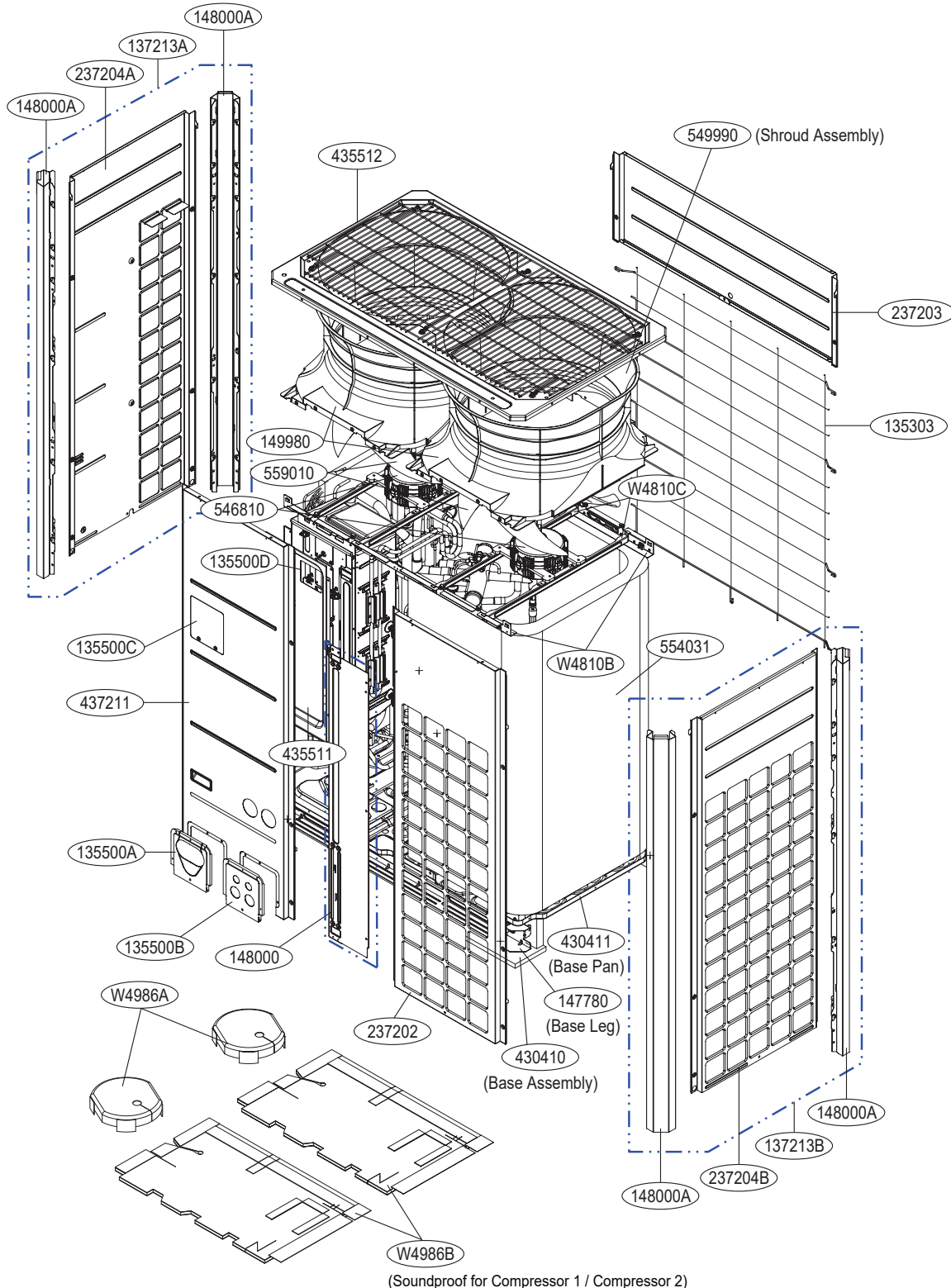

Parts

**Note:**

Actual component appearances may differ depending on manufacturing date, model, system type, etc.



# OUTDOOR UNIT PARTS

**MULTI V 5**

## Expanded Piping View

### Expanded Piping View for 6-Ton (Small Frame) Outdoor Units

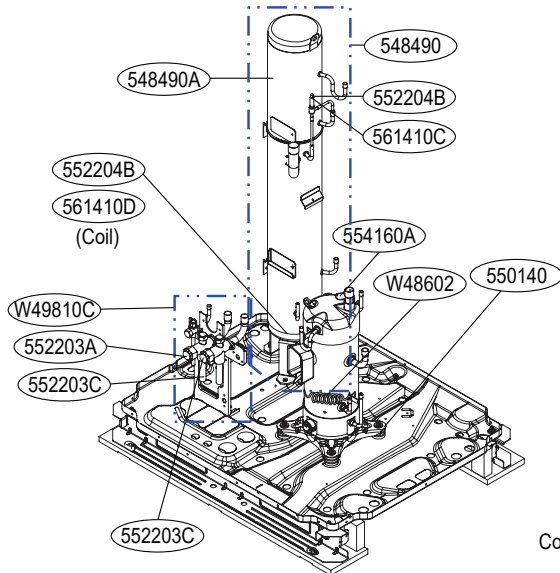
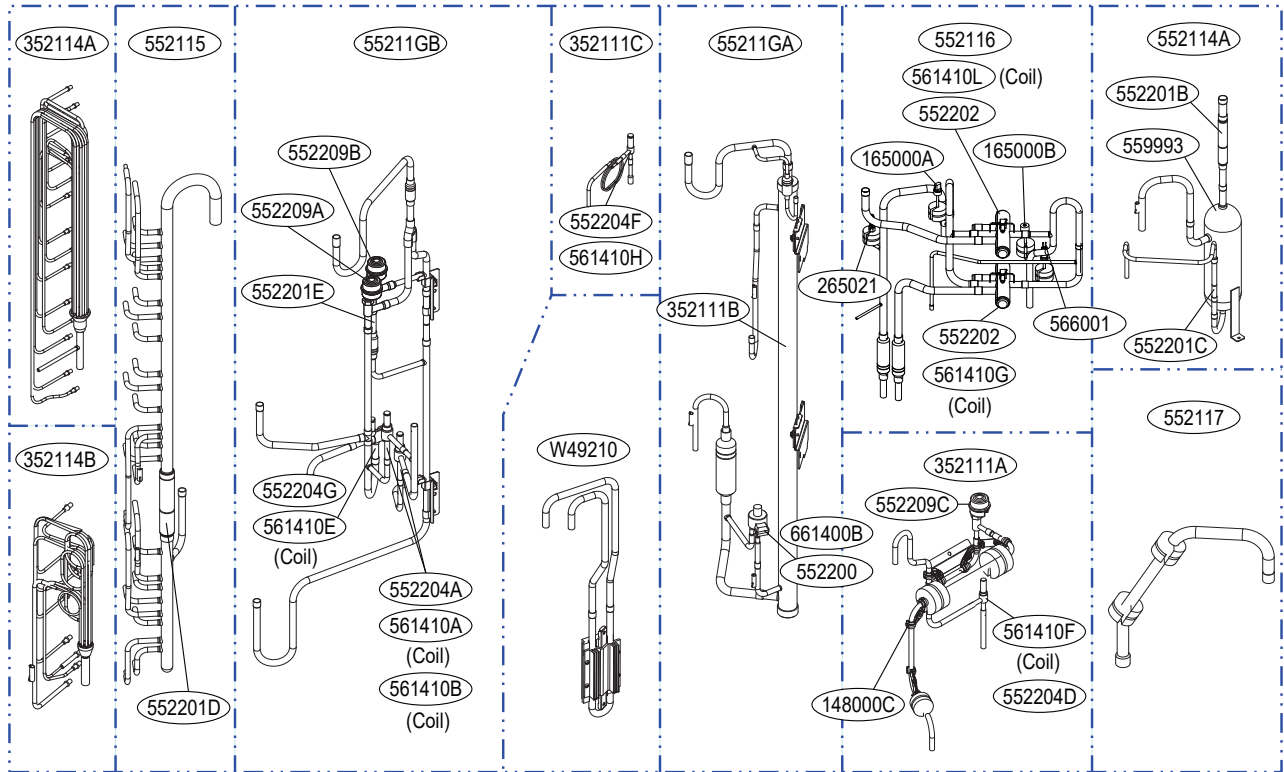

**Note:**

Actual component appearances may differ depending on manufacturing date, model, system type, etc.



Compressor 1 Oil Level Sensor    Compressor 1 Sump Heater

Table 98: Temperature Sensor Parts List for 6-Ton (Small Frame) Outdoor Units.

Type	Part No.	Description	Color
Temperature Sensor 1	263230A	Sub Cool Out + Heat Exchanger Upper Temperature Sensor 2 + Liquid Pipe	Yellow
Temperature Sensor 2	263230B	Suction Pipe + Heat Exchanger Temperature Sensor 1 + Inverter 1 Discharge	Purple
Temperature Sensor 3	263230C	Air	Green
Temperature Sensor 4	263230D	Heat Exchanger Lower Temperature Sensor 3 + Sub Cool In	Black



# OUTDOOR UNIT PARTS

**MULTI V 5**

## Expanded Piping View

### Expanded Piping View for 12- to 20-Ton (Large Frame) Outdoor Units

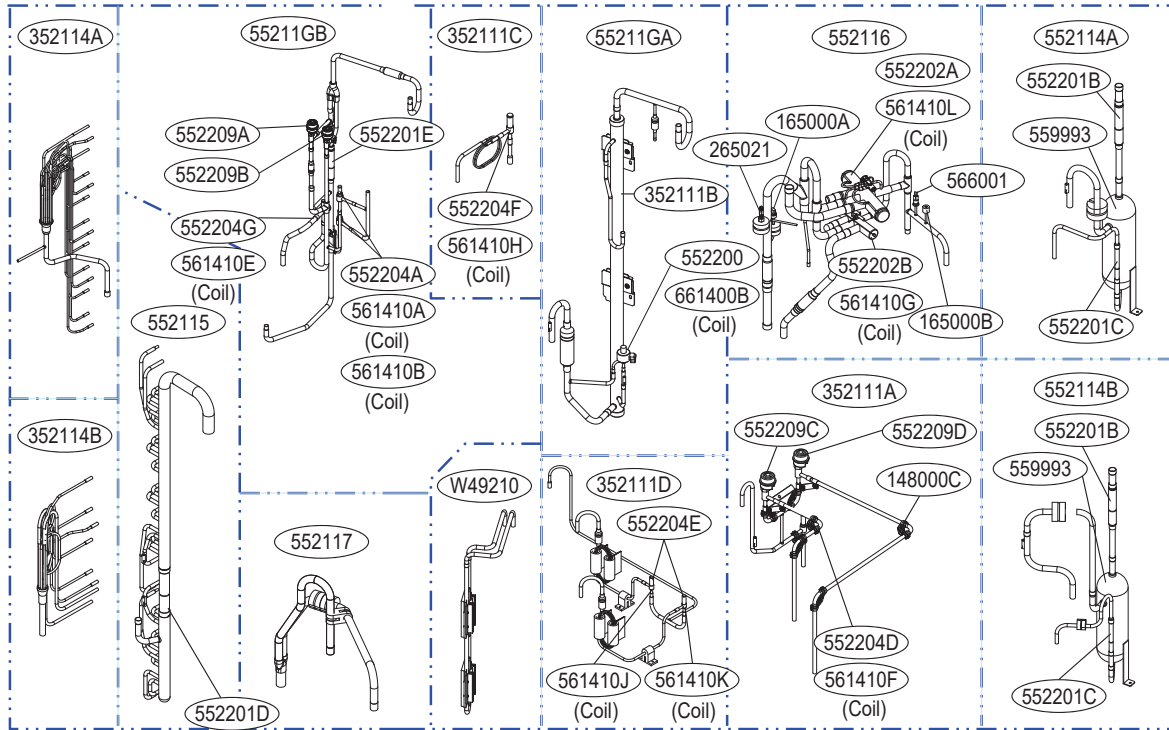

**Note:**

Actual component appearances may differ depending on manufacturing date, model, system type, etc.

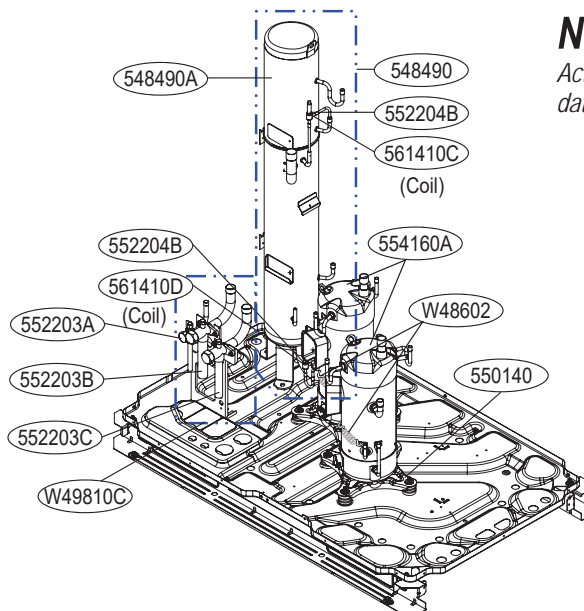

Table 100: Temperature Sensor Parts List for 8- and 10-Ton (Large Frame) Outdoor Units.

Type	Part No.	Description	Color
Temperature Sensor 1	263230A	Sub Cool Out + Heat Exchanger Upper Temperature Sensor 2 + Liquid Pipe	Yellow
Temperature Sensor 2	263230B	Suction Pipe + Heat Exchanger Temperature Sensor 1 + Inverter 1 Discharge	Purple
Temperature Sensor 3	263230C	Air	Green
Temperature Sensor 4	263230D	Heat Exchanger Lower Temperature Sensor 3 + Sub Cool In	Black

*Inverter*



**To access additional technical documentation such as submittals, indoor unit engineering manuals, installation, product data performance, general best practice, and building ventilation manuals, as well as white papers, catalogs, LATS software programs, and more, visit [www.lghvac.com](http://www.lghvac.com).**



LG Electronics, U.S.A., Inc.  
Air Conditioning Technologies  
4300 North Point Parkway  
Alpharetta, Georgia 30022  
[www.lghvac.com](http://www.lghvac.com)

LG Customer Information Center, Commercial Products

1-888-865-3026 USA

Follow the prompts for commercial A/C products.

SM\_MultiV\_5\_OutdoorUnits\_09\_18  
Supersedes: SM\_MultiV\_5\_OutdoorUnits\_07\_18