



MULTI VTM **S** **SERVICE MANUAL**

Variable Refrigerant Flow Outdoor Units
2 to 5 Tons



PROPRIETARY DATA NOTICE

This document, as well as all reports, illustrations, data, information, and other materials are the property of LG Electronics U.S.A., Inc., and are disclosed by LG Electronics U.S.A., Inc. only in confidence.

** Do not throw away, destroy, or lose this manual.
Please read carefully and store in a safe place for future reference.
Content familiarity is required for proper installation.**

The instructions included in this manual must be followed to prevent product malfunction, property damage, injury, or death to the user or other people. Incorrect operation due to ignoring any instructions will cause harm or damage. The level of seriousness is classified by the symbols described by the summary list of safety precautions on page 4.

For more technical materials such as submittals, catalogs, engineering, installation, best practices, and owner's manuals, visit www.lghvac.com.

For continual product development, LG Electronics U.S.A., Inc. reserves the right to change specifications without notice.

© LG Electronics U.S.A., Inc.

Safety Precautions	4-7	Troubleshooting Main Components	76-86
Nomenclature.....	8	<i>Test Run</i>	76
Wiring Diagrams	9-12	<i>Main Component Errors</i>	77
Refrigerant Flow Diagrams.....	13-26	<i>Self Diagnostics Check</i>	78
Outdoor Unit Functions	27-52	<i>Checking the Compressor</i>	79-80
<i>Basic Control</i>	27-28	<i>Checking the Outdoor Unit Fan Motor</i>	80
<i>Normal Operation/Compressor Control</i>	27	<i>Checking the Electronic Expansion Valves</i>	81-83
<i>EEV Control</i>	28	<i>Checking the Inverter IPM / IGBT</i>	84-85
<i>Special Control</i>	29-31	<i>Checking the High / Low Pressure Sensors</i>	85
<i>Oil Return Control</i>	29	<i>Checking the Outdoor Fan</i>	86
<i>Defrost Control</i>	30	<i>Checking the Four-Way Reverse Valve</i>	86
<i>Stop Operation</i>	31	<i>Checking the Temperature Sensors</i>	88
<i>Protection Control</i>	32-35	Error Codes.....	87-152
<i>Pressure Protection Control</i>	32-33	<i>Error Code General Information</i>	87
<i>Discharge Temperature/Inverter Protection/</i>		<i>Error Code Tables</i>	88-93
<i>Pressure Switch</i>	34-35	<i>Error Codes</i>	94-143
<i>Other Controls</i>	36-39	<i>Replacing the Inverter PCB Heat Sink</i>	144
<i>Initial Setup</i>	36-39	<i>Checking the Phase Diode Bridge</i>	145
<i>Setting Optional Modes</i>	40-52	<i>Checking Input Voltage in Case of Power On</i>	146
Heat Recovery Units.....	53-60	<i>Checking ODU to ODU Comm. (DC Voltage) in</i>	
<i>Parts Functions</i>	53	<i>Case of Power On</i>	147
<i>Dimensional Diagrams</i>	54-56	<i>Checking Inverter PCB in Case of Power Off</i>	148-150
<i>Wiring Diagram</i>	57	<i>Checking Main PCB in Case of Power Off</i>	151
<i>Refrigerant Circuit Diagram</i>	58	<i>PCB Locations</i>	152
<i>Functions</i>	59-60	Parts.....	153-166
PCB Settings.....	61-75	<i>PCBs</i>	153-155
<i>Heat Recovery Unit Settings</i>	61-66	<i>Control Box</i>	156-158
<i>Indoor Unit Addressing</i>	67-69	<i>Expanded Frame View</i>	159-161
<i>Pipe Detection Addressing</i>	70-75	<i>Expanded Piping View</i>	162-165

The instructions below must be followed to prevent product malfunction, property damage, injury or death to the user or other people. Incorrect operation due to ignoring any instructions will cause harm or damage. The level of seriousness is classified by the symbols described below.

TABLE OF SYMBOLS

DANGER	<i>This symbol indicates an imminently hazardous situation which, if not avoided, will result in death or serious injury.</i>
WARNING	<i>This symbol indicates a potentially hazardous situation which, if not avoided, could result in death or serious injury.</i>
CAUTION	<i>This symbol indicates a potentially hazardous situation which, if not avoided, may result in minor or moderate injury.</i>
Note:	<i>This symbol indicates situations that may result in equipment or property damage accidents only.</i>
	<i>This symbol indicates an action that must not be performed.</i>

INSTALLATION

DANGER

Do not store or use flammable gas or combustibles near the unit.
There is risk of fire, explosion, and physical injury or death.

Do not supply power to the unit until all wiring and piping are completed or reconnected and checked.
There is risk of physical injury or death due to electric shock.

WARNING

Do not install or remove the unit by yourself (end user). Ask the dealer or an authorized technician to install the unit. Improper installation by the user will result in fire, explosion, electric shock, physical injury or death.

For replacement of an installed unit, always contact an LG trained service provider.
There is risk of fire, electric shock, explosion, and physical injury or death.

Wear protective gloves when handling equipment. Sharp edges will cause personal injury.

Do not change the settings of the protection devices. If the protection devices have been bypassed or are forced to operate improperly, or parts other than those specified by LG are used, there is risk of fire, electric shock, explosion, and physical injury or death.

Replace all control box and panel covers.
If cover panels are not installed securely, dust, water and animals will enter the outdoor unit, causing fire, electric shock, and physical injury or death.

Always check for system refrigerant leaks after the unit has been installed or serviced.
Exposure to high concentration levels of refrigerant gas will lead to illness or death.

Periodically check that the outdoor frame is not damaged.
There is a risk of explosion, physical injury, or death.

If the air conditioner is installed in a small space, take measures to prevent the refrigerant concentration from exceeding safety limits in the event of a refrigerant leak. Consult the latest edition of ASHRAE (American Society of Heating, Refrigerating, and Air Conditioning Engineers) Standard 15. If the refrigerant leaks and safety limits are exceeded, it could result in personal injuries or death from oxygen depletion.

The heat recovery unit must be installed indoors; do not install the heat recovery unit in a highly humid environment.
There is risk of physical injury or death due to electric shock.

Dispose the packing materials safely.

- Packing materials, such as nails and other metal or wooden parts, will cause puncture wounds or other injuries.
- Tear apart and throw away plastic packaging bags so that children will not play with them and risk suffocation and death.

Install the unit considering the potential for strong winds or earthquakes.
Improper installation will cause the unit to fall over, resulting in physical injury or death.

Install the unit in a safe location where nobody can step, fall onto it, or place objects on it. Do not install the unit on a defective stand.
It will result in an accident that causes physical injury or death.

⚠ WARNING

Properly insulate all cold surfaces to prevent “sweating.”

Cold surfaces such as uninsulated piping can generate condensate that could drip, causing a slippery surface that creates a risk of slipping, falling, and personal injury.

⚠ CAUTION

Be very careful when transporting the product. There is a risk of the product falling and causing physical injury.

- Use appropriate moving equipment to transport each frame; ensure the equipment is capable of supporting the weights listed.
- Some products use polypropylene bands for packaging. Ⓣ Do not use polypropylene bands to lift the unit.
- Suspend the outdoor unit from the base at specified positions (at a minimum of six [6] points) to avoid slippage from rigging apparatus.

Note:

LG Electronics U.S.A., Inc., is not responsible for any piping calculations, refrigerant leaks, degradation of performance, or any other potential problems or damages as a result of interconnecting piping, their joint connections, isolation valves, introduced debris inside the piping system, or other problems caused by the interconnecting piping system.

Ⓣ **Do not install the product where it is exposed directly to ocean winds.**

Sea salt in the air will cause the product to corrode. Corrosion, particularly on the condenser and evaporator fins, could cause product malfunction or inefficient operation.

When installing the outdoor unit in a low-lying area, or a location that is not level, use a raised concrete pad or concrete blocks to provide a solid, level foundation.

This prevents water damage and abnormal vibration.

Properly insulate all cold surfaces to prevent “sweating.”

Cold surfaces such as uninsulated piping can generate condensate that will drip and cause a slippery surface condition and / or water damage to walls.

Always check for system refrigerant leaks after the unit has been installed or serviced.

Low refrigerant levels will cause product failure.

Ⓣ **Do not make refrigerant substitutions. Use R410A only.**

If a different refrigerant is used, or air mixes with original refrigerant, the unit will malfunction and be damaged.

Ⓣ **Do not store or use flammable gas / combustibles near the unit.**

There is a risk of product failure.

Ⓣ **Do not use the product for mission critical or special purpose applications such as preserving foods, works of art, or other precision air conditioning applications. The equipment is designed to provide comfort cooling and heating.**

There is risk of property damage.

Keep the unit upright during installation to avoid vibration or water leakage.

When installing the unit in a hospital, mechanical room, or similar electromagnetic field (EMF) sensitive environment, provide sufficient protection against electrical noise.

Inverter equipment, power generators, high-frequency medical equipment or radio communication equipment will cause the air conditioner to operate improperly. The unit will also affect such equipment by creating electrical noise that disturbs medical treatment or image broadcasting.

The heat recovery box must be installed indoors; Ⓣ do not install the heat recovery box in a highly humid environment.

There is risk of product failure and property damage.

When connecting refrigerant piping, remember to allow for pipe expansion.

Improper piping will cause system malfunction.

Ⓣ **Do not install the outdoor unit or heat recovery unit in a noise-sensitive area.**

Take appropriate actions at the end of HVAC equipment life to recover, recycle, reclaim or destroy R410A refrigerant according to applicable U.S. Environmental Protection Agency (EPA) rules.

Periodically check that the outdoor frame is not damaged.

There is a risk of equipment damage.

Install the unit in a safe location where nobody can step on or fall onto it. Ⓣ Do not install the unit on a defective stand.

There is a risk of unit and property damage.

Install the drain hose to ensure adequate drainage.

There is a risk of water leakage and property damage.

WIRING

DANGER

High voltage electricity is required to operate this system. Adhere to the U.S. National Electric Code NEC and these instructions when wiring.

Improper connections and inadequate grounding can cause accidental injury or death.

Always ground the unit following local, state, and NEC codes.
There is risk of fire, electric shock, and physical injury or death.

Turn the power off at the nearest disconnect before servicing the equipment.

Electrical shock can cause physical injury or death.

Properly size all circuit breakers or fuses.

There is risk of fire, electric shock, explosion, physical injury or death.

Do not share the electrical circuit with other devices.

There is risk of fire, electric shock, and physical injury or death due to heat generation.

Do not use damaged or loose power wiring. **Do not modify or extend the outdoor unit's power wiring randomly. Ensure that the power wiring will not be pulled nor weight be placed on the power wiring during operation.**

There is risk of fire, electric shock, and physical injury or death.

WARNING

The information contained in this manual is intended for use by an industry-qualified, experienced, certified electrician familiar with the NEC who is equipped with the proper tools and test instruments.

Failure to carefully read and follow all instructions in this manual can result in personal injury or death.

All electric work must be performed by a licensed electrician and conform to local building codes or, in the absence of local codes, with the NEC, and the instructions given in this manual.

If the power source capacity is inadequate or the electric work is not performed properly, it will result in fire, electric shock, physical injury or death.

Refer to local, state, and federal codes, and use power wires of sufficient current capacity and rating.

Wires that are too small will generate heat and cause a fire, and physical injury or death.

Secure all field wiring connections with appropriate wire strain relief.

Improperly securing wires will create undue stress on equipment power lugs. Inadequate connections will generate heat, cause a fire, and physical injury or death.

Ensure the system is connected to a dedicated power source that provides adequate power.

If the power source capacity is inadequate or the electric work is not performed properly, it will result in fire, electric shock, physical injury or death.

Properly tighten all power connections.

Loose wiring will overheat at connection points, causing a fire, physical injury or death.

Do not change the settings of the protection devices.

If the protection devices have been bypassed or is forced to operate improperly, or parts other than those specified by LG are used, there is risk of fire, electric shock, explosion, and physical injury or death.

Note:

Do not supply power to the unit until all electrical wiring, controls wiring, piping, installation, and refrigerant system evacuation are completed.

The system will malfunction.

The information contained in this manual is intended for use by an industry-qualified, experienced, certified electrician familiar with the NEC who is equipped with the proper tools and test instruments.

Failure to carefully read and follow all instructions in this manual can result in equipment malfunction and property damage.

OPERATION

⚠ DANGER

⊘ Do not provide power to or operate the unit if it is flooded or submerged.

There is risk of fire, electric shock, physical injury or death.

Use a dedicated breaker for this product.

There is risk of fire, electric shock, physical injury or death.

⊘ Do not operate the disconnect switch with wet hands.

There is risk of fire, electric shock, physical injury or death.

Periodically verify the equipment mounts have not deteriorated.

If the base collapses, the unit could fall and cause physical injury or death.

Use inert (nitrogen) gas when performing leak tests or air purges. ⊘ Do not use compressed air, oxygen, or flammable gases.

Using these substances will cause fire, explosion, and physical injury or death.

If refrigerant leaks out, ventilate the area before operating the unit.

If the unit is mounted in an enclosed, low-lying, or poorly ventilated area, and the system develops a refrigerant leak, it will cause a fire, electric shock, explosion, physical injury or death.

⚠ WARNING

⊘ Do not allow water, dirt, or animals to enter the unit.

There is risk of fire, electric shock, physical injury or death.

⊘ Do not operate the unit with the panel(s) or protective cover(s) removed; keep fingers and clothing away from moving parts.

The rotating, hot, cold, and high-voltage parts of the unit can cause physical injury or death.

⊘ Do not touch the refrigerant piping during or after operation.

It can cause burns or frostbite.

⊘ Do not open the inlet during operation.

There is risk of electric shock, physical injury or death.

⚠ CAUTION

⊘ To avoid physical injury, use caution when cleaning or servicing the air conditioner.

There is risk of electric shock, physical injury or death.

Note:

Clean up the site after servicing is finished, and check that no metal scraps, screws, or bits of wiring have been left inside or surrounding the unit.

⊘ Do not use the product for mission critical or special purpose applications such as preserving foods, works of art, or other precision air conditioning applications. The equipment is designed to provide comfort cooling and heating.

There is risk of property damage.

⊘ Do not allow water, dirt, or animals to enter the unit.

There is risk of unit failure.

⊘ Do not open the inlet during operation.

There is risk of unit failure.

⊘ Do not operate the unit with the panel(s) or protective cover(s) removed; keep fingers and clothing away from moving parts.

Non-secured covers can result in malfunction due to dust or water in the service panel.

Periodically verify the equipment mounts have not deteriorated.

If the base collapses, the unit could fall and cause property damage or product failure.

Use only a soft cloth to clean the air conditioner. ⊘ Do not use wax, thinner, or strong detergents.

Strong cleaning products will damage the surface of the air conditioner, or will cause its appearance to deteriorate.

Provide power to the outdoor unit to warm the compressor crankcase at least six (6) hours before operation begins.

Starting operation with a cold compressor sump(s) will result in severe bearing damage to the compressor(s). Keep the power switch on during the operational season.

⊘ Do not turn off the main power switch after operation has been stopped.

Wait at least five (5) minutes before turning off the main power switch, otherwise it will result in product malfunction.

⊘ Do not block the inlet or outlet.

Unit will malfunction.

Auto-addressing must be performed after connecting the power of all indoor and outdoor units.

Auto-addressing must also be performed after servicing an indoor unit.

Outdoor Units (ODU)

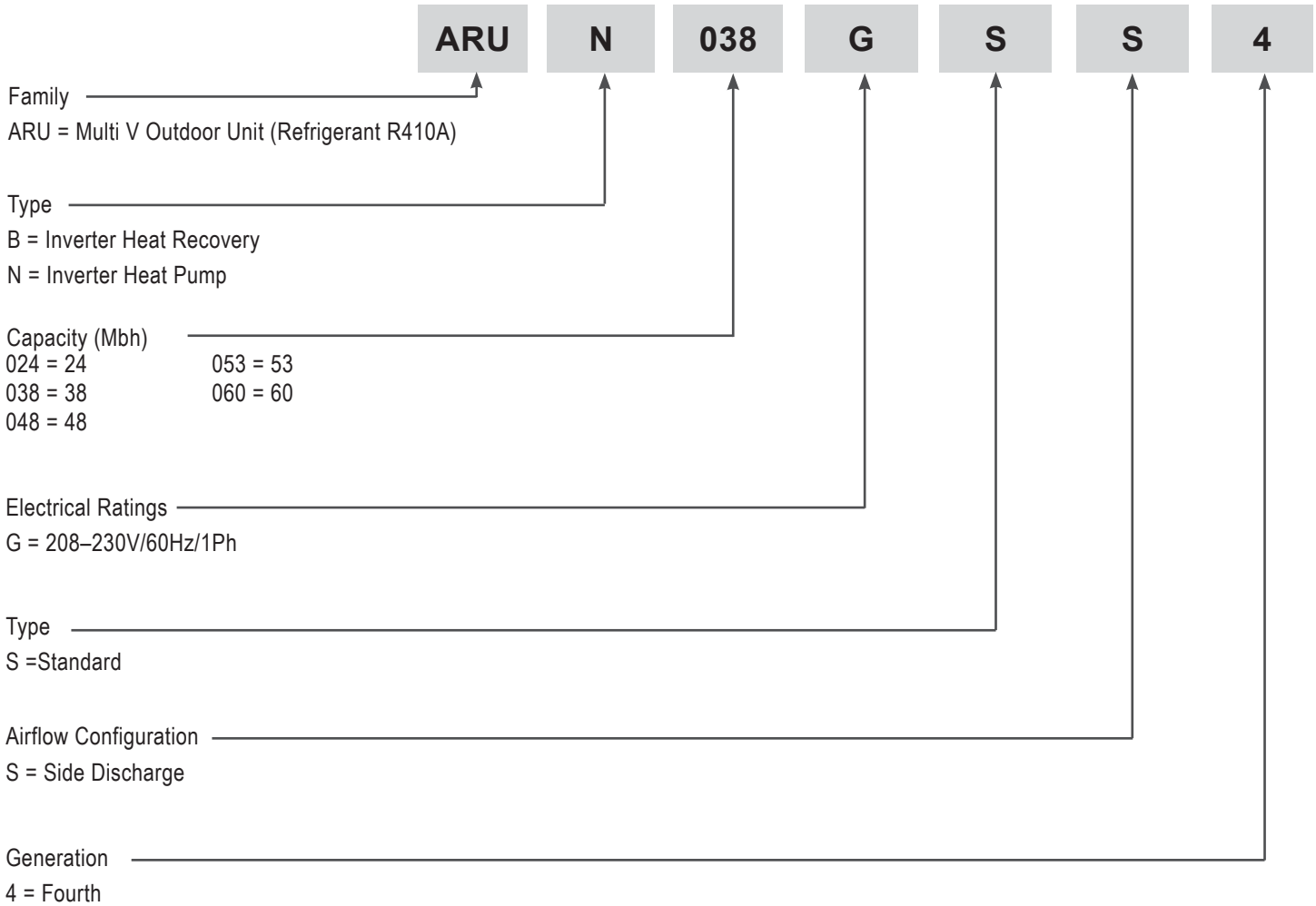

Heat Recovery Units (HRU)

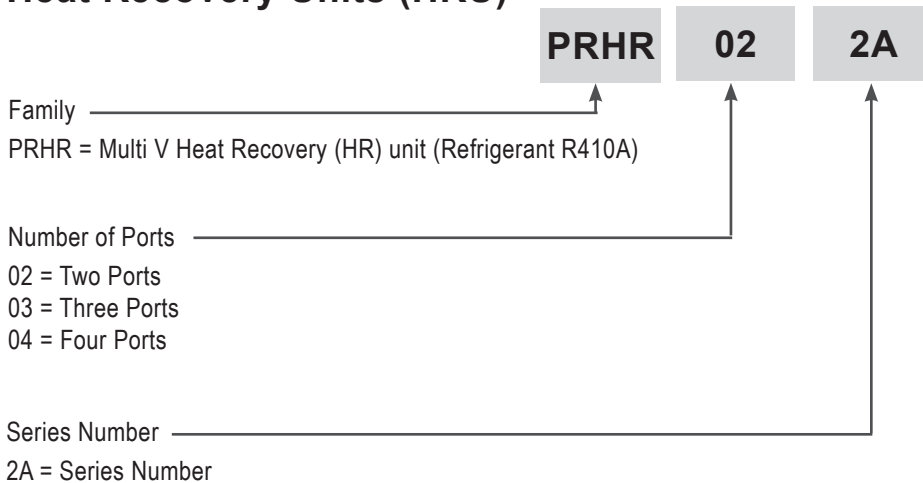

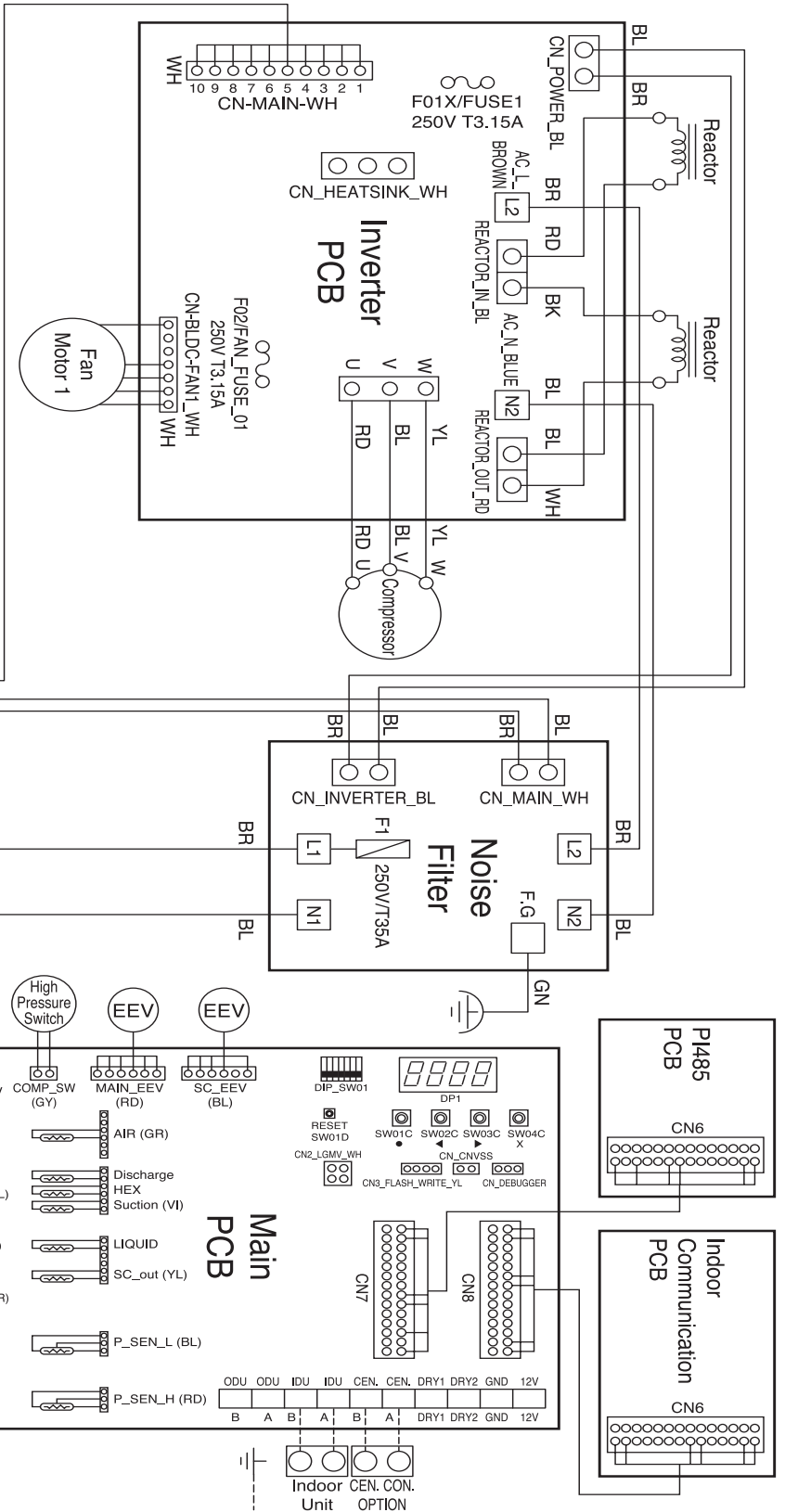

◆ Main PCB Note

SYMBOL	DESCRIPTION
CN2	LGWV MONITORING TERMINAL
CN7	OPTION PCB COMMUNICATION TERMINAL
CN8	OPTION PCB COMMUNICATION TERMINAL
CN3	HOT GAS BYPASS VALVE
CN4	4WAY REVERSING VALVE
CN1	OUTDOOR AIR THERMISTOR
CN12(Suction)	SUCTION PIPE THERMISTOR
CN12(Heat)	CONDENSOR PIPE THERMISTOR
CN12(Discharge)	INVERTER COMP. DISCHARGE PIPE THERMISTOR
CN13(SC_out)	SUBCOOLING OUTLET PIPE THERMISTOR
CN13(LIQUID)	LIQUID PIPE THERMISTOR
CN14(MAIN_EEV)	ELECTRIC EXPANSION VALVE(MAIN)
CN15(SC_EEV)	ELECTRIC EXPANSION VALVE(SUBCOOLING)
CN16	LOW PRESSURE SENSOR
CN17	HIGH PRESSURE SENSOR
CN18	LOW PRESSURE SENSOR
CN19	INVERTER COMP. HIGH PRESSURE SWITCH
CN20	INVERTER PCB COMMUNICATION TERMINAL
CN21	AC POWER 220V
CN22	RESET BUTTON
CN23	AUTO ADDRESSING BUTTON

◆ Inverter PCB Note

SYMBOL	DESCRIPTION
CN_MAIN_WH	MAIN PCB COMMUNICATION TERMINAL
CN_BLDG_FAN1	COMMUNICATION & POWER INPUT OF FAN MOTOR
CN_AC_INPUT	AC POWER 220V
CN_LGMV	TERMINAL FOR LGWV JIG OF INVERTER

◆ Note

1. ----- : Field Wiring

2. ----- : Factory Wiring

◆ Color

SYMBOL	RD	BL	WH	BR	BK	YL	GN/YL
COLOR	RED	BLUE	WHITE	BLACK	BROWN	YELLOW	GREEN/YELLOW

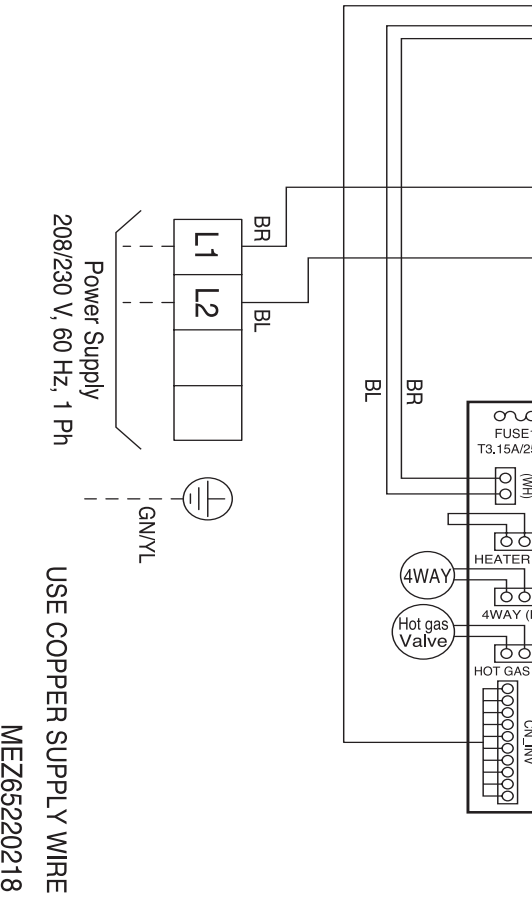

WIRING DIAGRAMS

Heat Pump Units — ARUN038GSS4, ARUN048GSS4, ARUN053GSS4

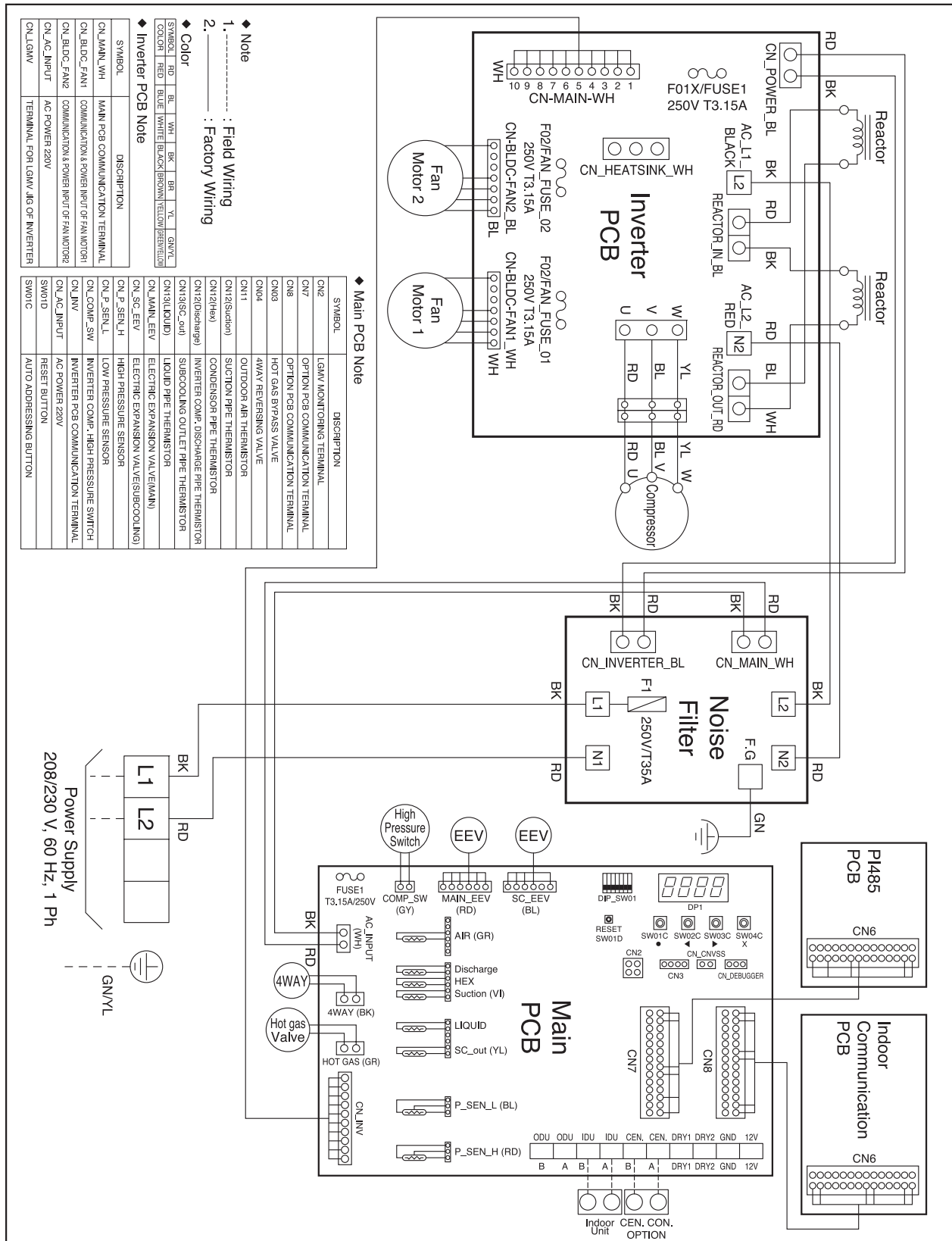

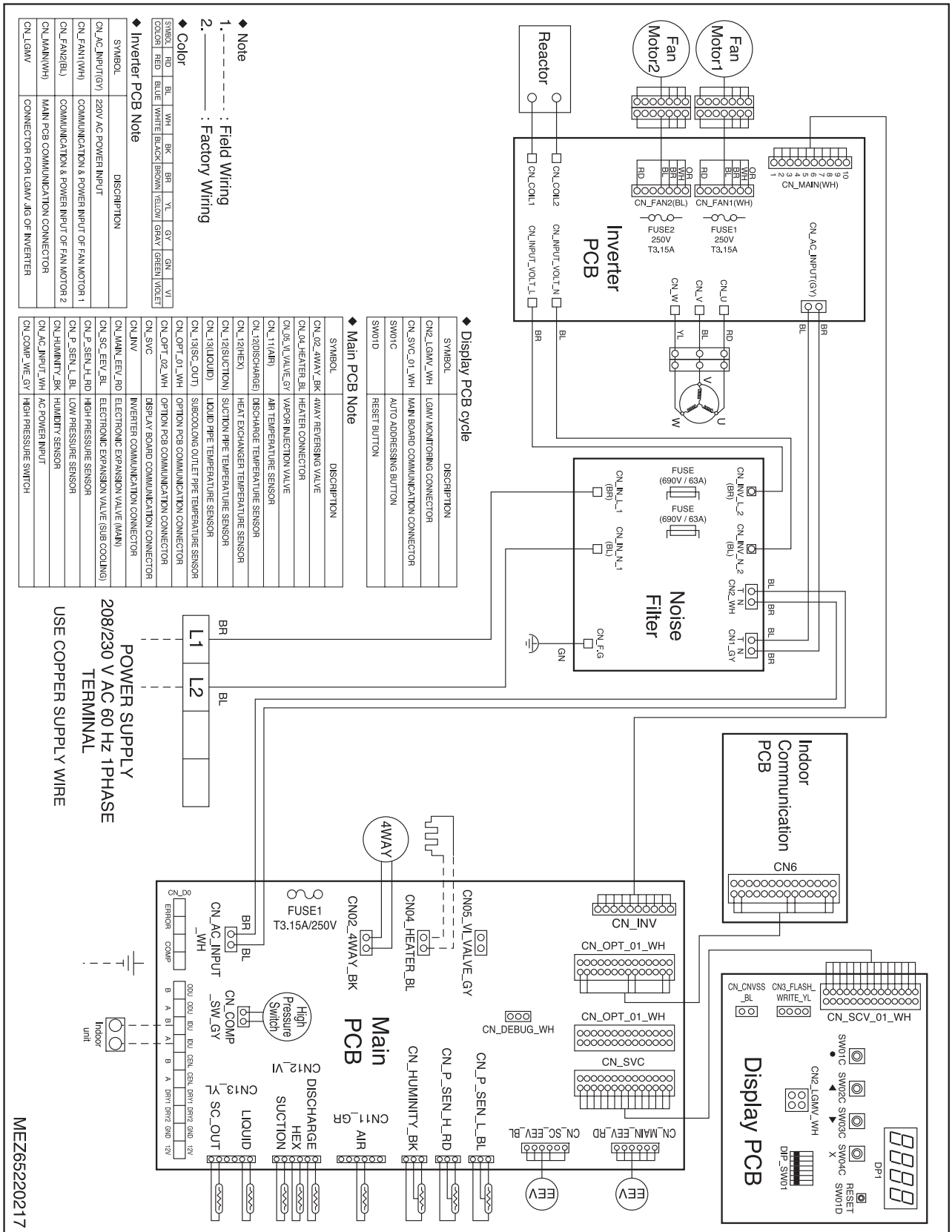

MEZ65220217

WIRING DIAGRAMS

Heat Recovery Unit — ARUB060GSS4

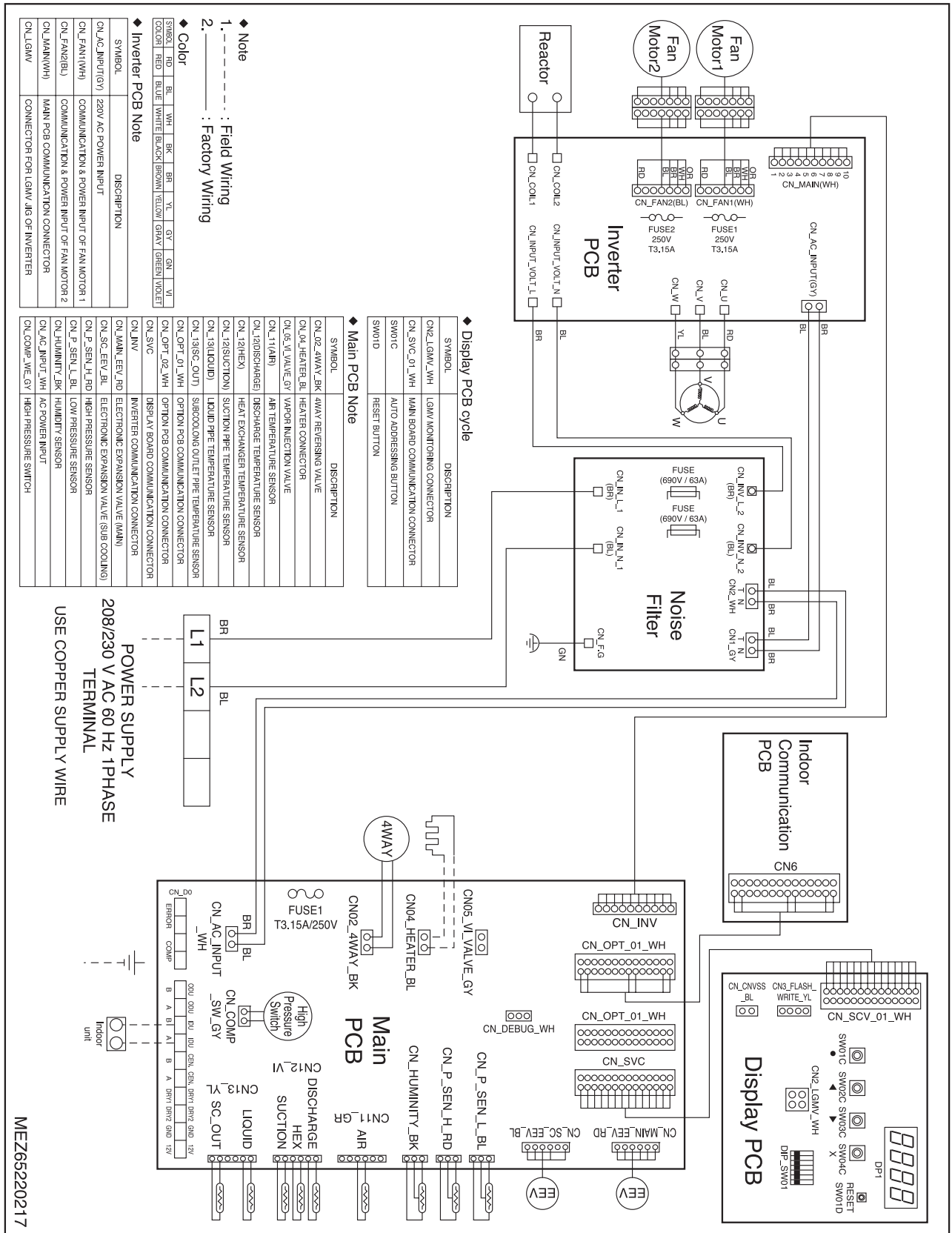

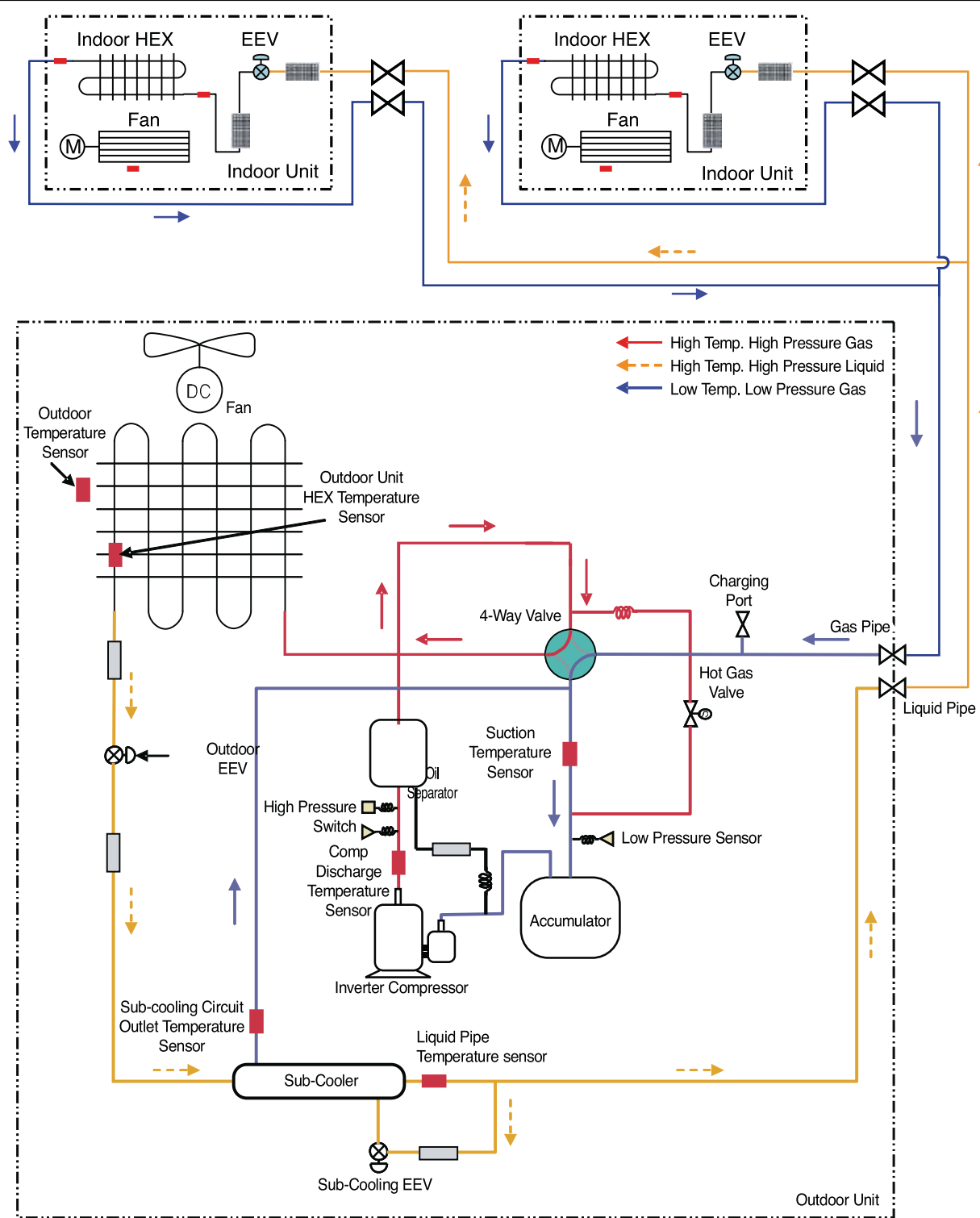

Outdoor Unit Functions

Remarks	Pressure Sensor	Temperature Sensor	SVC Valve	EEV	Strainer
	Pressure Sensor				

REFRIGERANT FLOW DIAGRAMS

Heat Pump Unit — ARUN024GSS4

Heating Mode

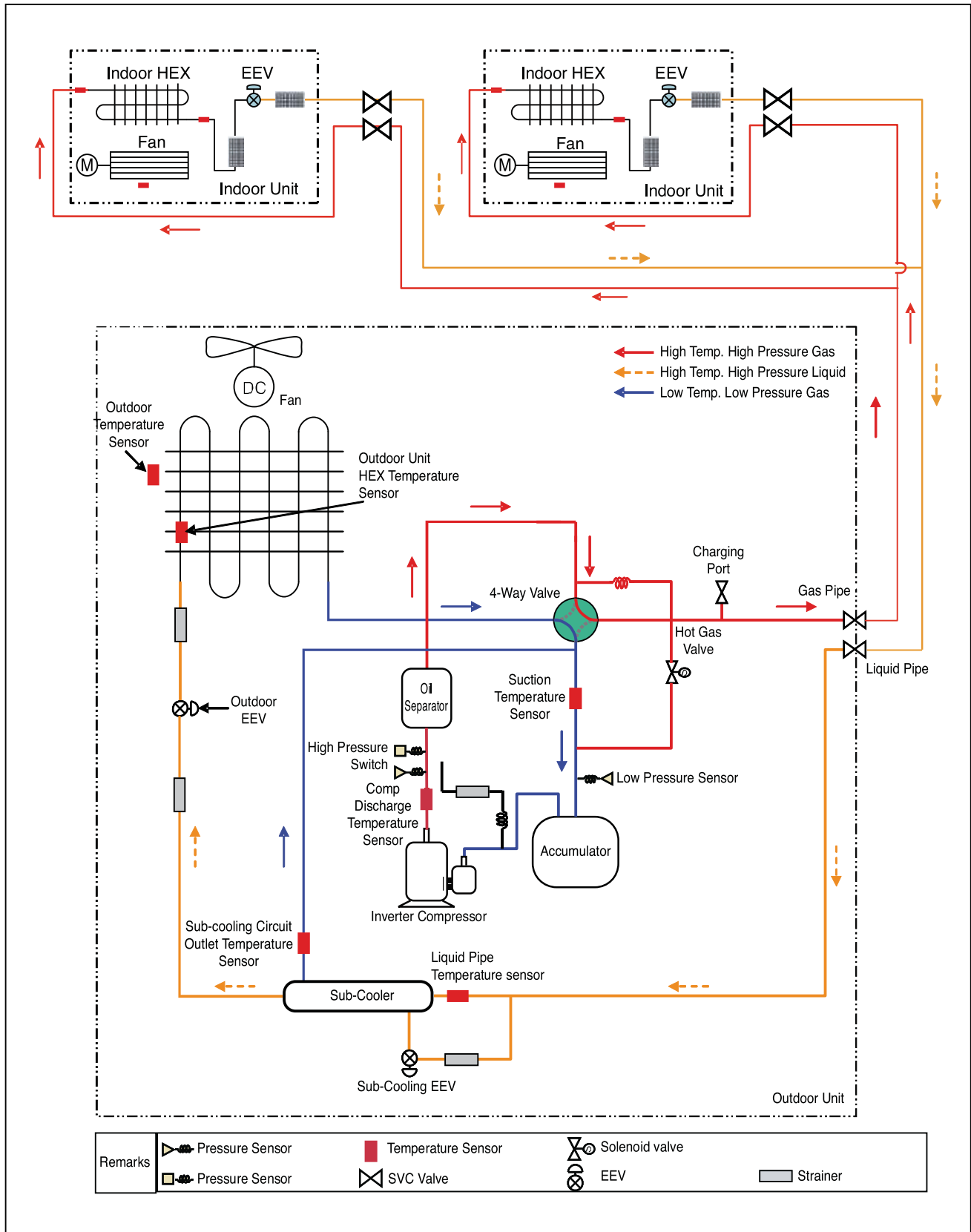

MULTI V S Outdoor Unit Service Manual

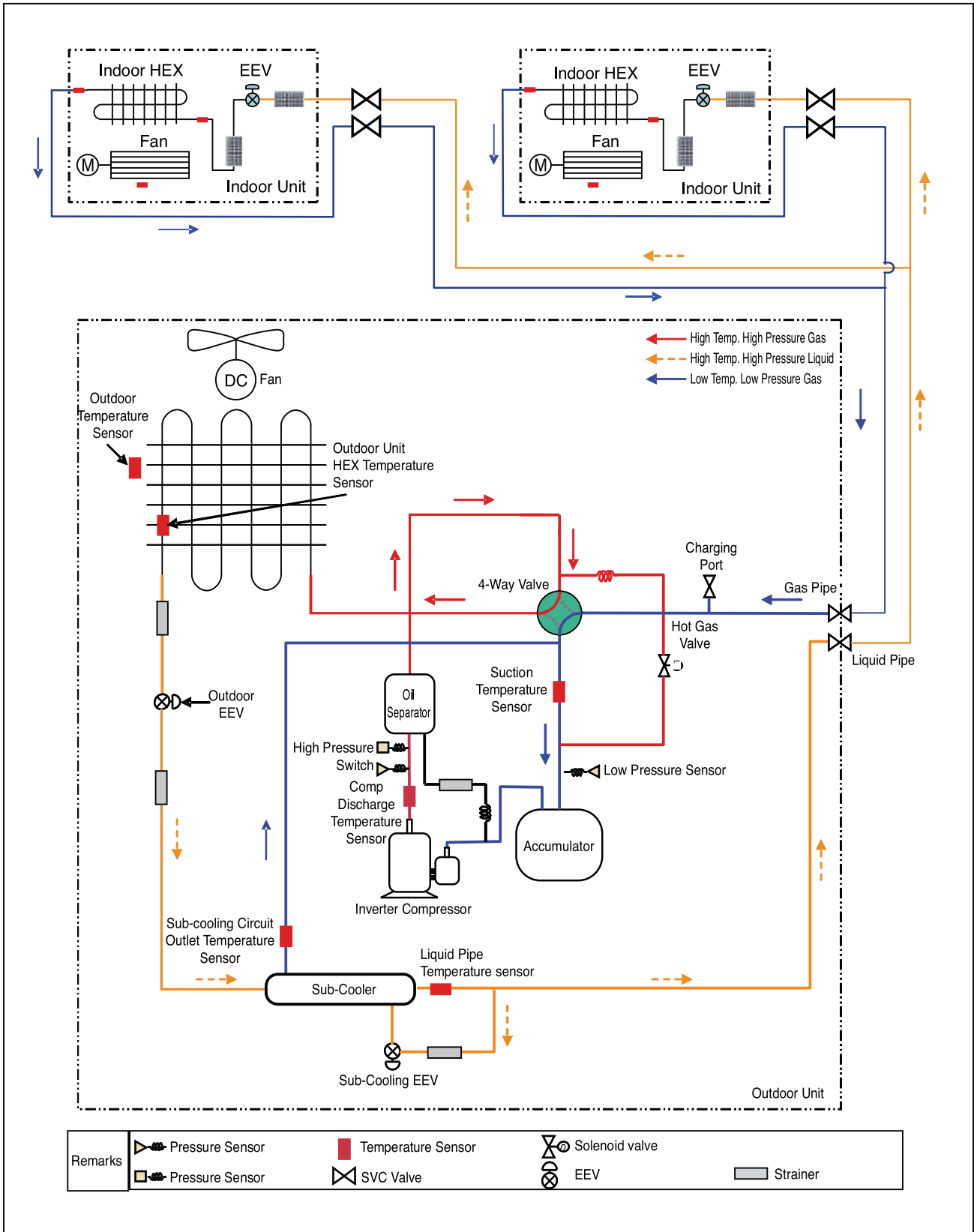

REFRIGERANT FLOW DIAGRAMS

Heat Pump Units — ARUN038GSS4, ARUN048GSS4, ARUN053GSS4

Cooling Mode

MULTI V S Outdoor Unit Service Manual

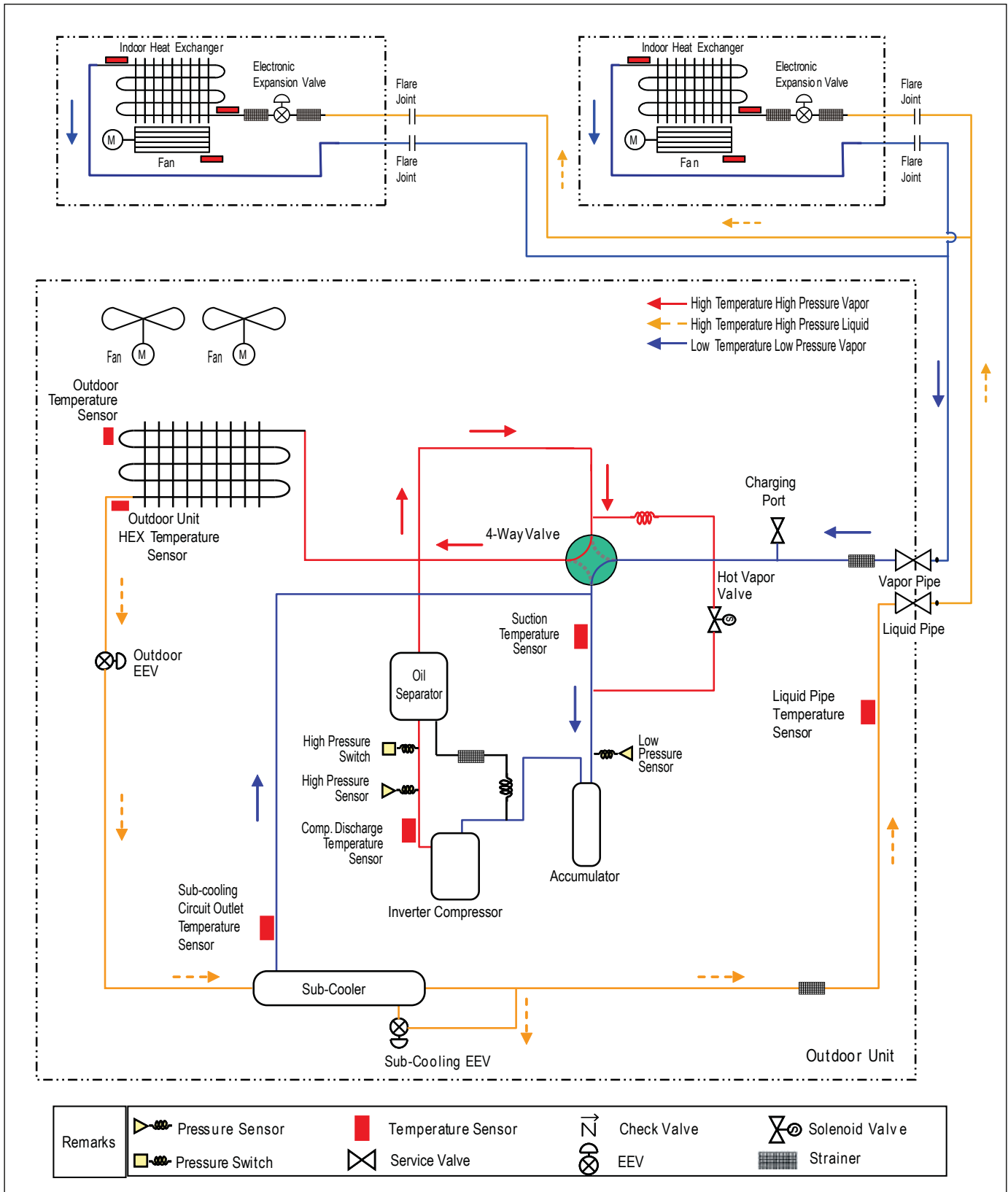

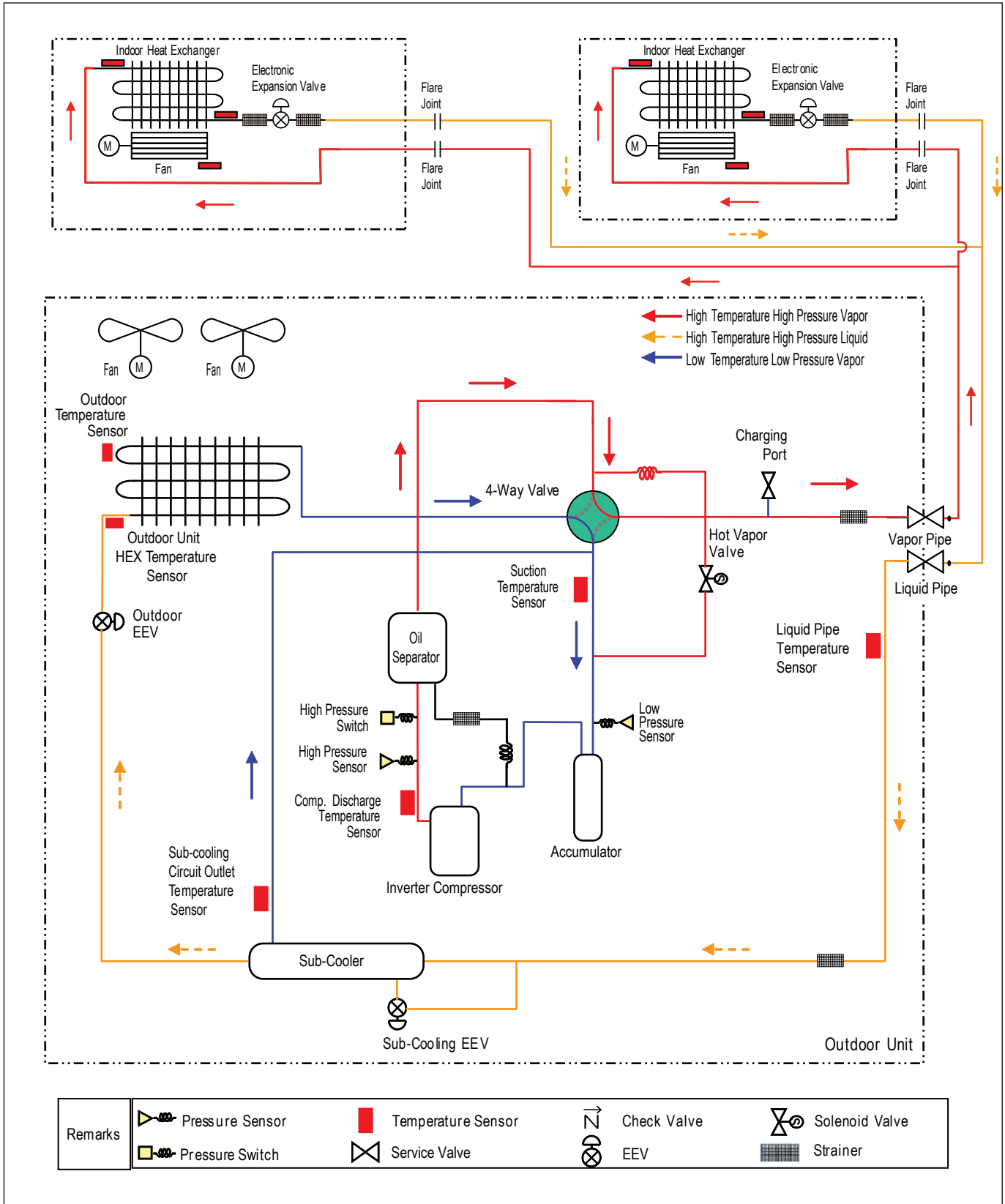

Outdoor Unit Functions

REFRIGERANT FLOW DIAGRAMS

Heat Pump Units — ARUN038GSS4, ARUN048GSS4, ARUN053GSS4
Oil Return / Defrost

MULTI V S Outdoor Unit Service Manual

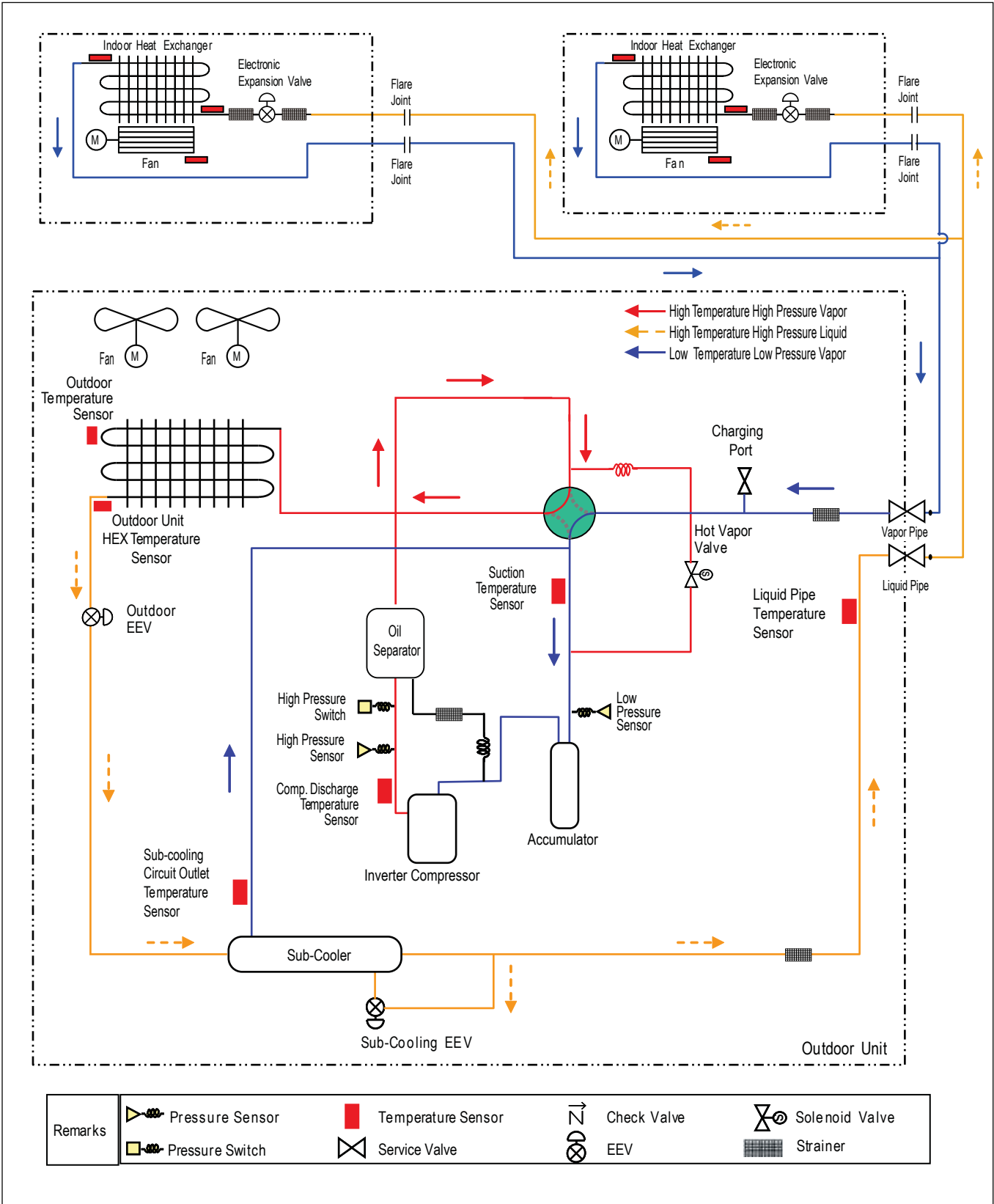

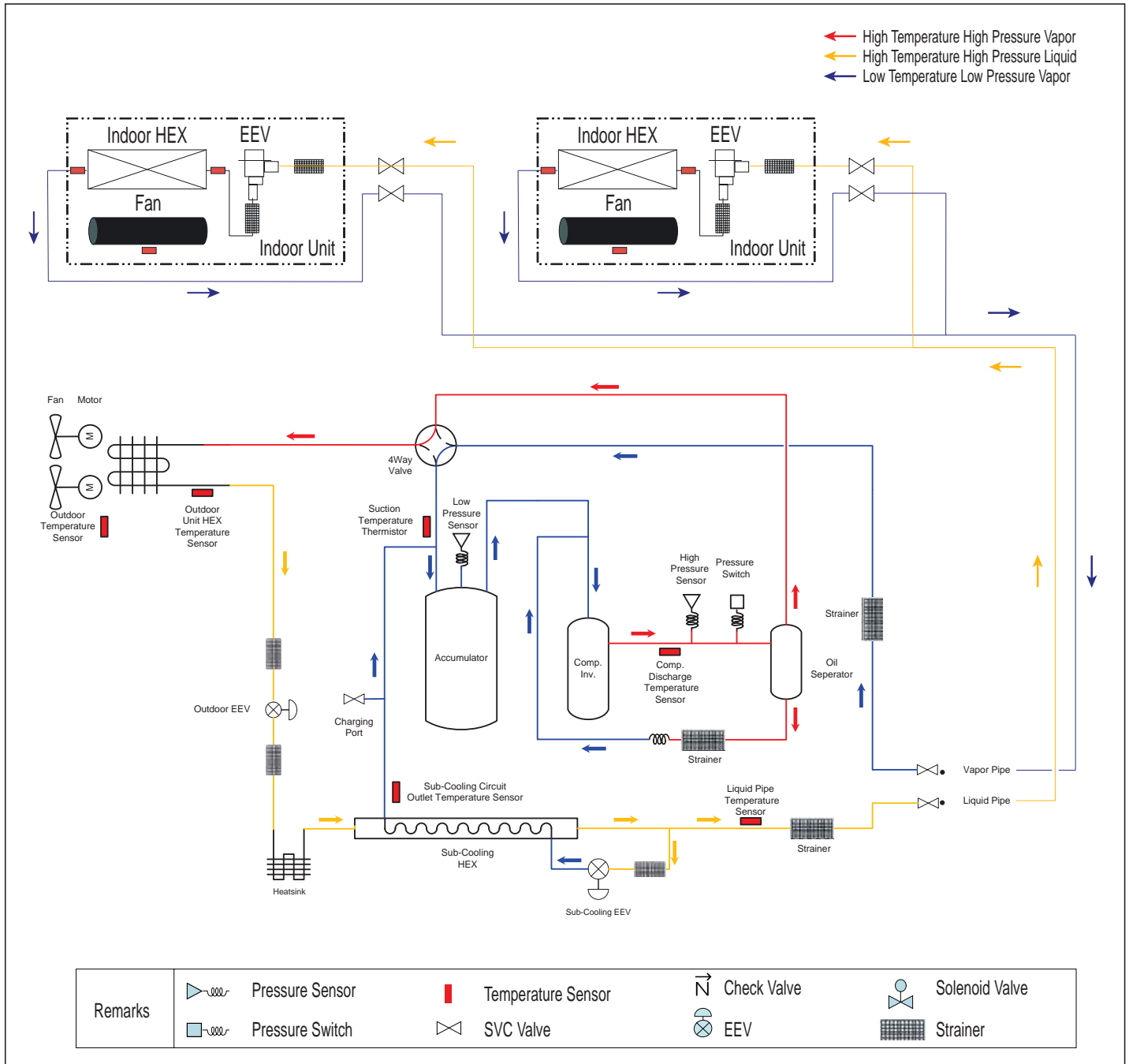

REFRIGERANT FLOW DIAGRAMS

Heat Pump Unit — ARUN060GSS4

Heating Mode

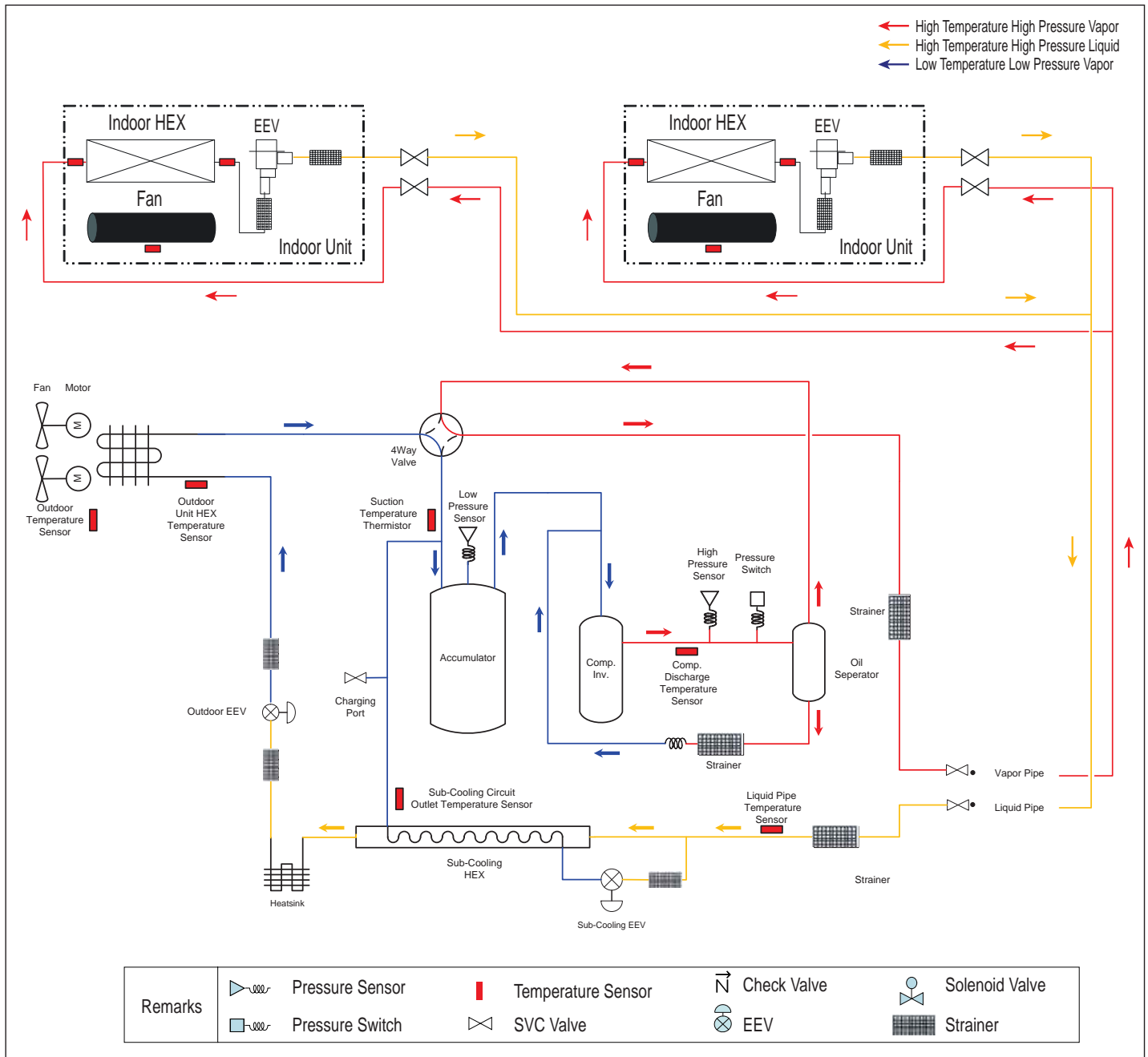

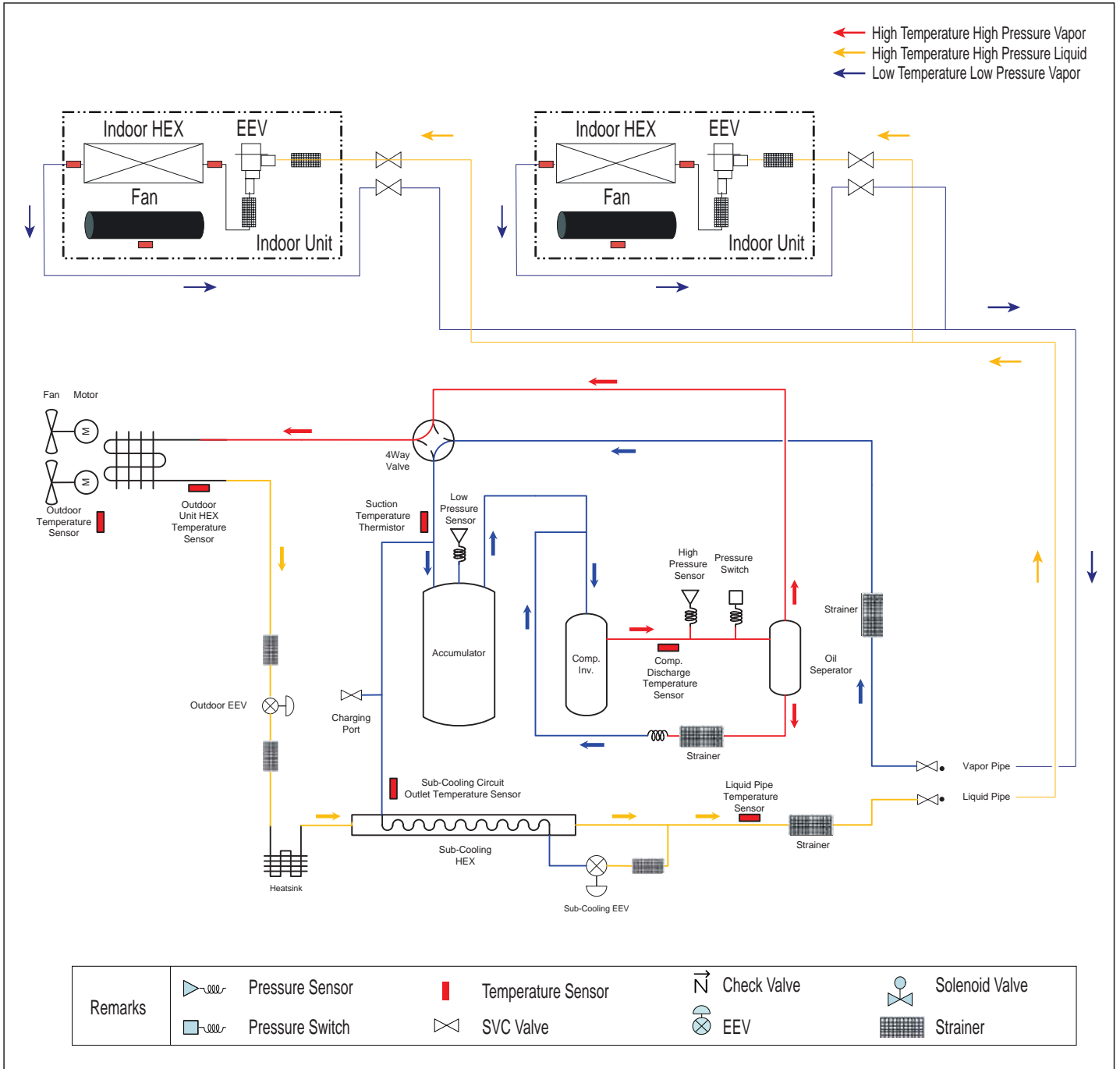

REFRIGERANT FLOW DIAGRAMS



Heat Recovery Unit — ARUB060GSS4

Cooling Mode

MULTI V S Outdoor Unit Service Manual

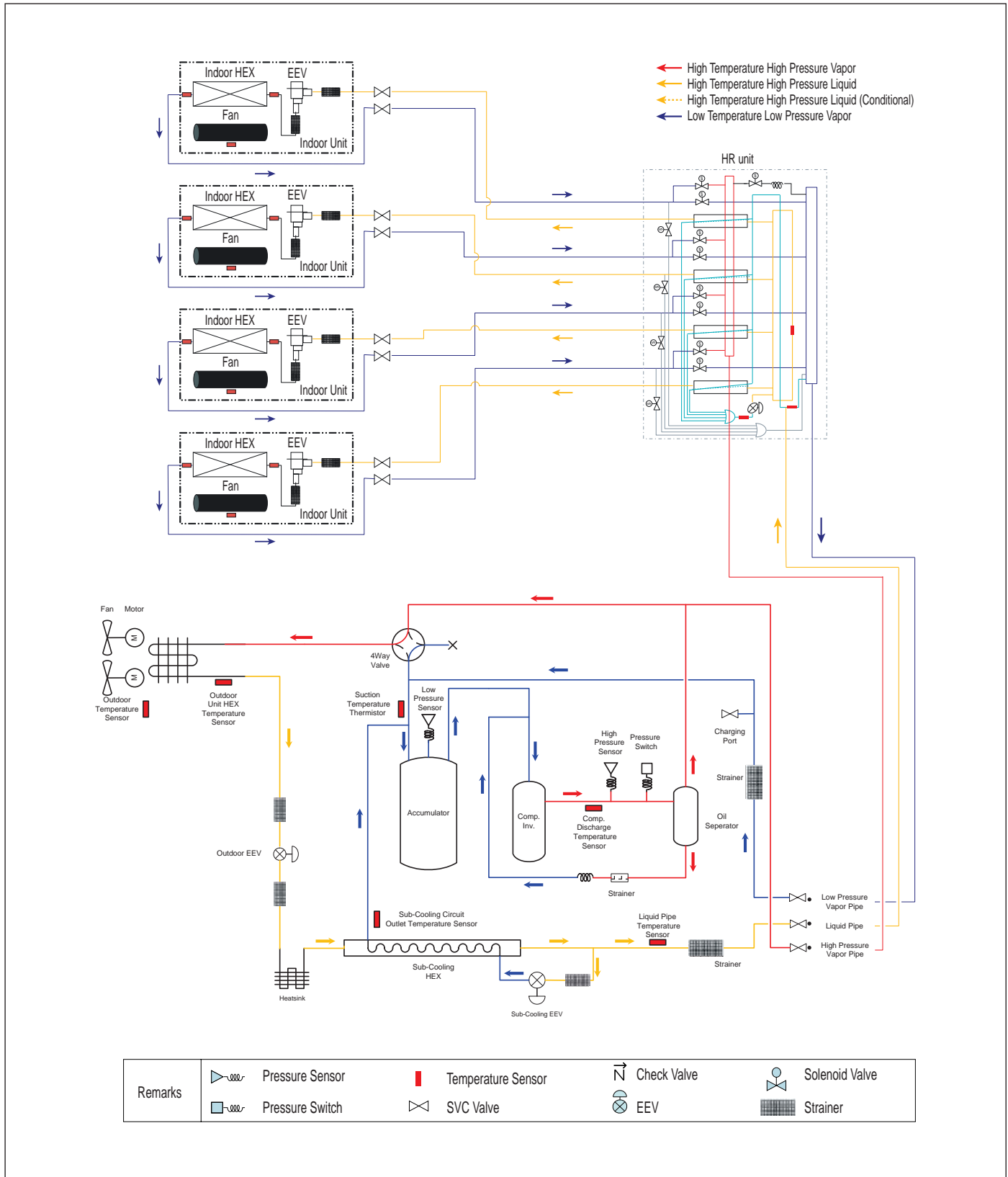

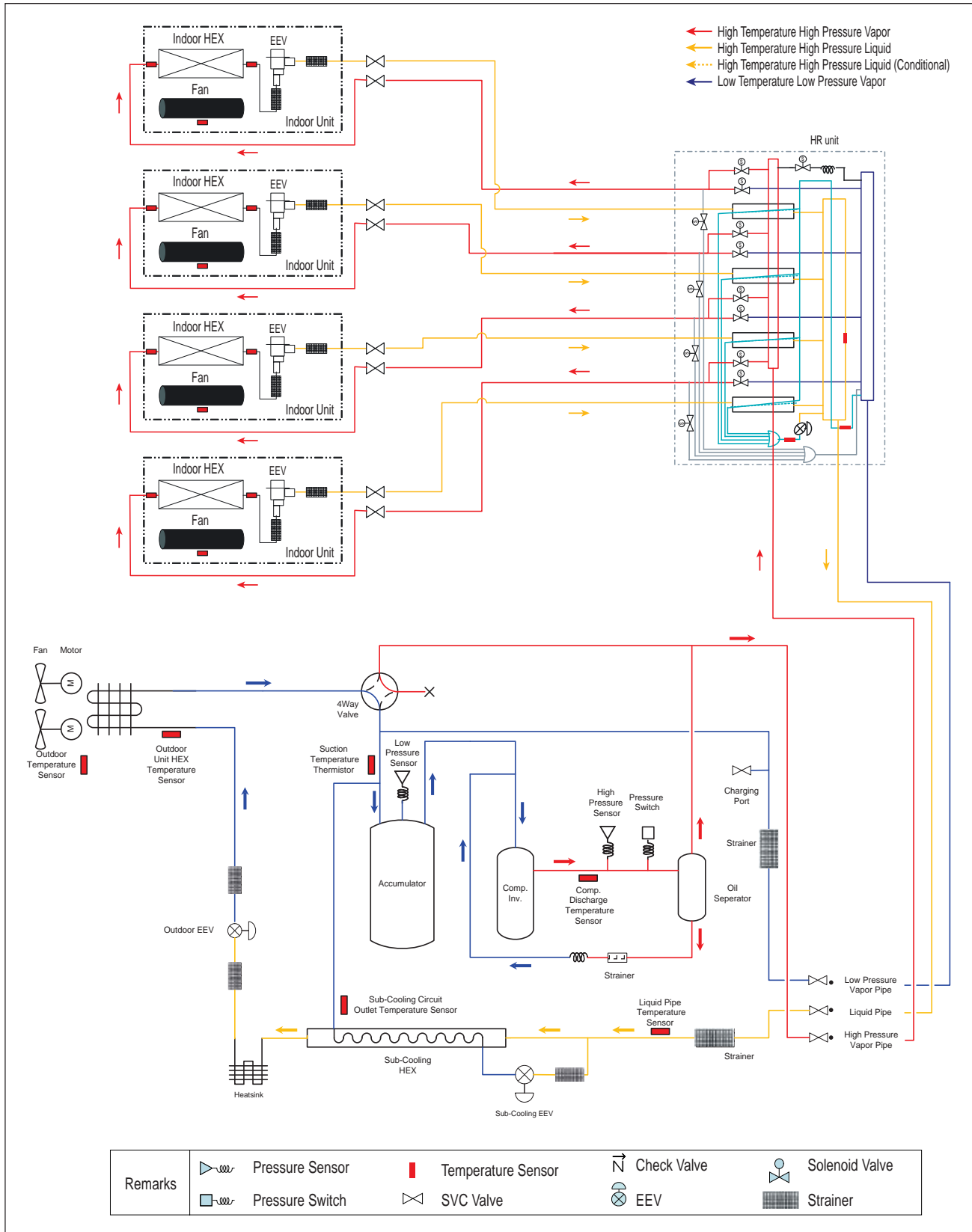

Outdoor Unit Functions

REFRIGERANT FLOW DIAGRAMS

MULTI V[™]S

Heat Recovery Unit — ARUB060GSS4

Cooling-Based Simultaneous Mode

MULTI V S Outdoor Unit Service Manual

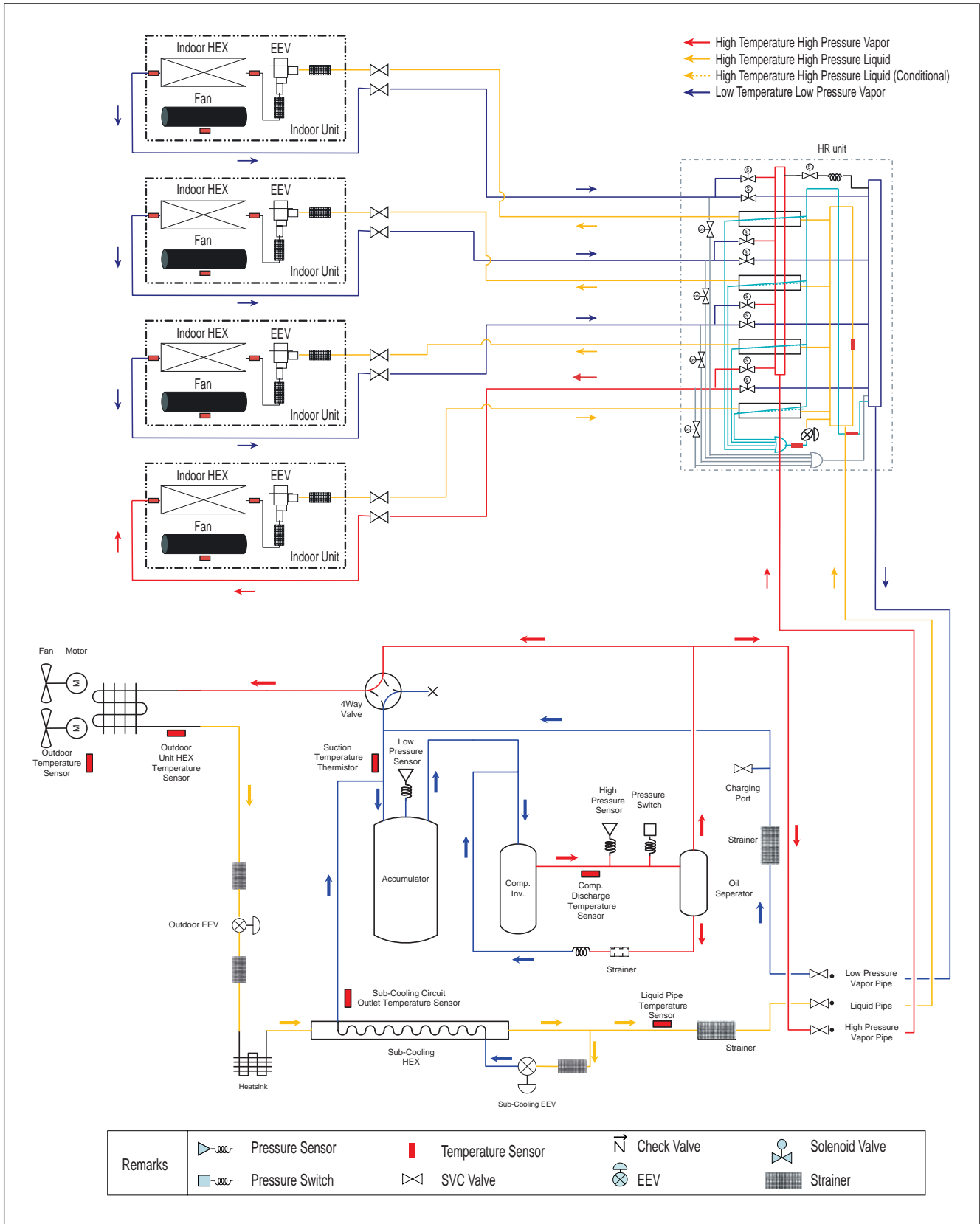

REFRIGERANT FLOW DIAGRAMS

Heat Recovery Unit — ARUB060GSS4
Heating-Based Simultaneous Mode

Outdoor Unit Functions

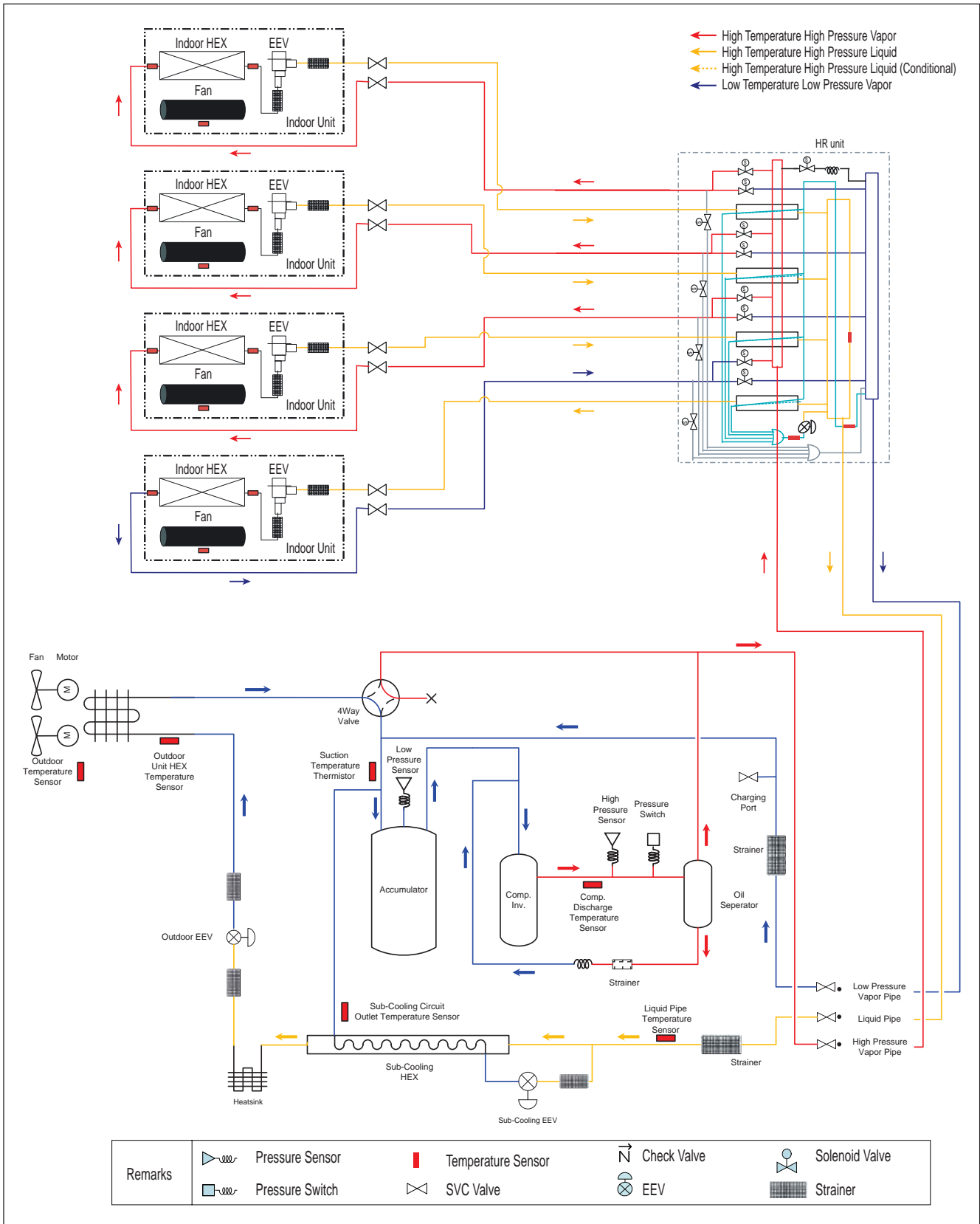

REFRIGERANT FLOW DIAGRAMS

Heat Recovery Unit — ARUB060GSS4

Oil Return and Defrost

MULTI V S Outdoor Unit Service Manual

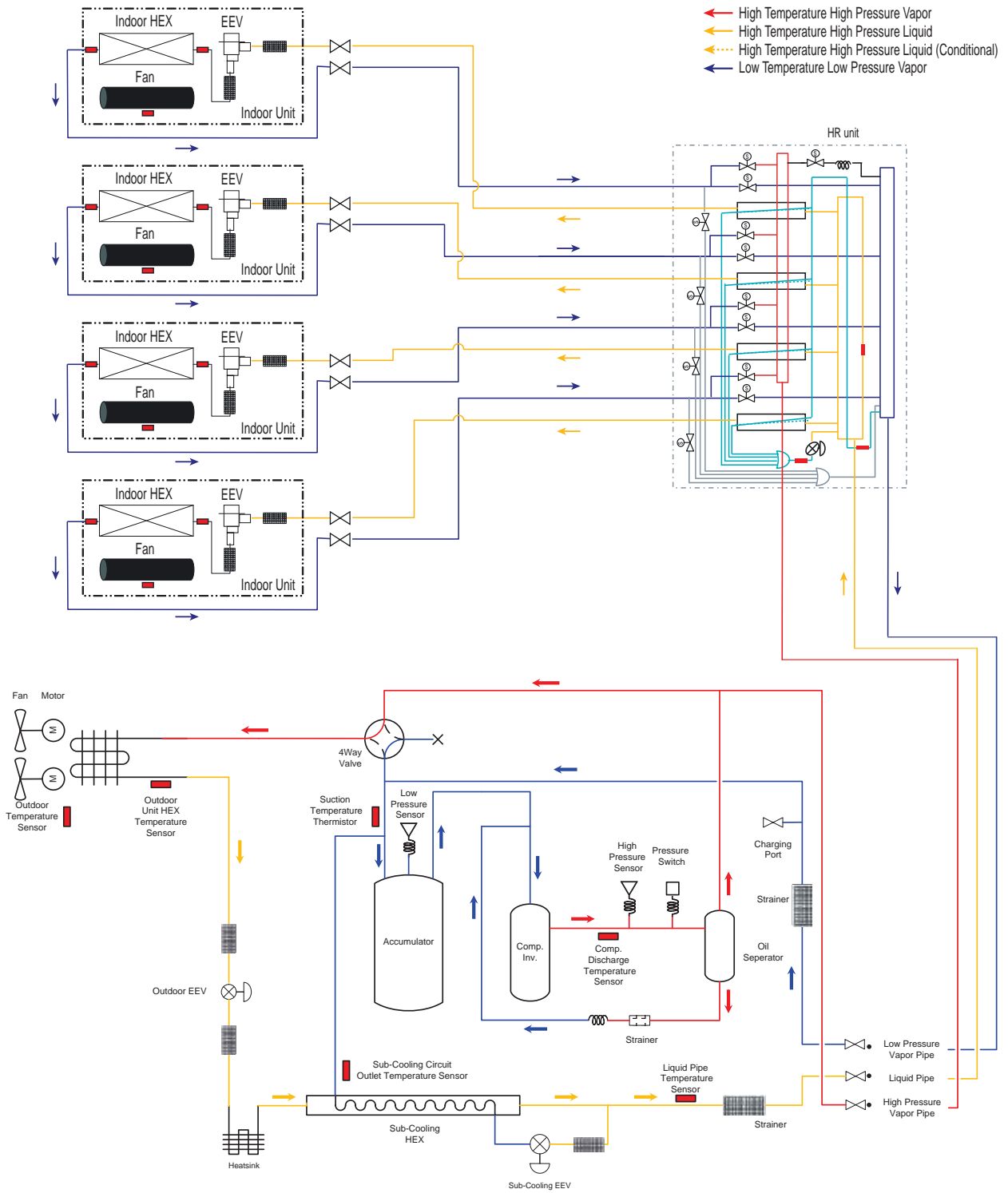

Remarks		Pressure Sensor		Temperature Sensor		Check Valve		Solenoid Valve
		Pressure Switch		SVC Valve		EEV		Strainer

Normal Operation

Table 1: Normal Operation Functions.

Component	Cooling Operation	Heating Operation	System Not in Operation
Compressor	Fuzzy Logic	Fuzzy Logic	Stop
Fan	Fuzzy Logic	Fuzzy Logic	Stop
Main EEV	Fully Open	Fuzzy Logic	Close
Four-Way Valve	Off	On	One (1) 1 hour after Heating Mode Stops and Outdoor Temperature is > 86°F: OFF
Subcooling EEV	Fuzzy Logic	Fuzzy Logic	Close
Indoor Unit EEV	Superheat Fuzzy Logic	Subcool Fuzzy Logic	Close

Note:

- Heating operation will not function if outdoor air temperature is $\geq 80.6^{\circ}F$.
- Cooling operation will not function if outdoor air temperature is $\leq 35.6^{\circ}F$ with an indoor unit combination is $\leq 10\%$.

Compressor Control

Fuzzy logic helps ensure stable system performance by maintaining a constant evaporating temperature (Te) in cooling mode, and a constant condensing temperature (Tc) in heating mode. Both Te (cooling) and Tc (heating) can be set at various steps in the installation mode.

- Cooling Mode (Te): 35.6~41°F
- Heating Mode (Tc): 116.6~123.8°F

Note:

Te and Tc can be determined simultaneously by setting DIP switches.

Figure 1: Fuzzy Logic Diagram.

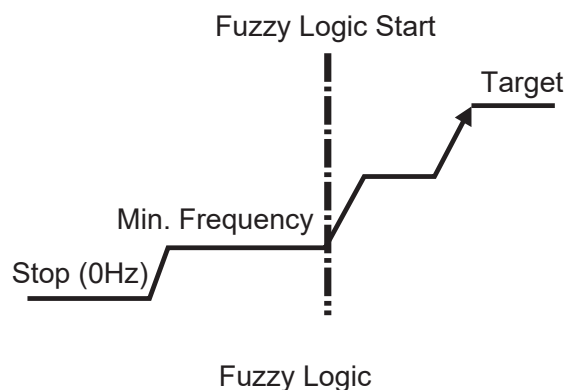
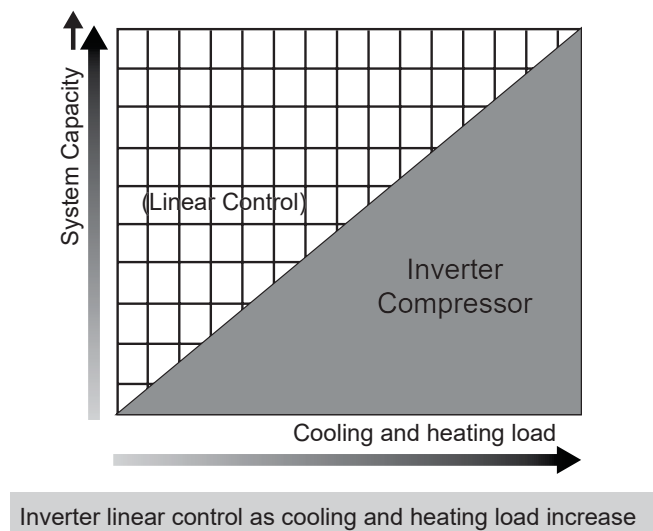

Figure 2: Inverter Linear Control Chart.



EEV Control

Main EEV Control

Main EEV operates with fuzzy logic to keep the degree of superheat (about 37.4°F) at the evaporator outlet stable during heating mode.

Degree of Superheat = $T_{\text{suction}} - T_{\text{evaporation}}$

where,

- T_{suction} = Temperature measured at the suction pipe sensor (°F).
- $T_{\text{evaporation}}$ = Evaporation temperature equivalent to low pressure (°F).

Subcooling EEV Control

Subcooling EEV operates with fuzzy logic to keep the degree of subcool (about 59°F) at the outlet of the subcooler stable during cooling mode.

Degree of Subcool = $T_{\text{condensation}} - T_{\text{liquid}}$

where,

- T_{liquid} = Temperature at the outlet of the subcooler (°F).
- $T_{\text{condensation}}$ = Condensation temperature equivalent to high pressure (°F).

⊗ Avoiding Excessively High Discharge Temperatures

After the main EEV opens to a predetermined amount, and the discharge temperature is above 185°F in heating mode, the subcooling EEV will control the subcooling outlet temperature / evaporating temperature to some difference.

Oil Return Control

Oil return operation recovers any oil that has accumulated in the piping and returns it to the compressor. Each component operates as shown in the tables below during oil return.

Oil Return in Cooling Mode

Table 2: Outdoor Unit Oil Return Control in Cooling Mode.

Component	Start	During Oil Return Operation	Stop
Inverter Compressor	30Hz	Set Value	30Hz
Fan	Normal Control	Normal Control	Normal Control
Main EEV	Maximum Pulse	Maximum Pulse	Maximum Pulse
Subcooling EEV	Minimum Pulse	Minimum Pulse	Minimum Pulse
Four-Way Valve	Off	Off	Off
Hot Gas Bypass Valve (ARUN024~053GSS4 Heat Pump Units Only)	Normal Control	Normal Control	Normal Control

Table 3: Indoor Unit Oil Return Control in Cooling Mode.

Component	Start	During Oil Return Operation	Stop
Fan	Normal Control	Normal control	Normal Control
Thermo On Unit EEV	Normal Control	Normal control	Normal Control
Thermo Off Unit EEV	40 Pulse	400 Pulse	40 Pulse
Oil Return Signal	Off	On	Off

- Start: Oil Return Operation will run every eight (8) hours.
- Oil Return Operation will run for three (3) minutes.
- Stop: Oil Return Operation will end if / when compressor protection control starts.

Oil Return Control in Heating Mode

Table 4: Outdoor Unit Oil Return Control in Heating Mode.

Component	Start	During Oil Return Operation	Stop
Inverter Compressor	30Hz	Set Value	40Hz
Fan	Off	Normal Control	Off
Main EEV	300 Pulse	Maximum Pulse	200 Pulse
Subcooling EEV	Minimum Pulse	Minimum Pulse	Minimum Pulse
Four-Way Valve	On	On → Off → On	On
Hot Gas Bypass Valve (ARUN024~053GSS4 Heat Pump Units Only)	Normal Control	Normal Control	Normal Control

Table 5: Indoor Unit Oil Return Control in Heating Mode.

Component	Start	During Oil Return Operation	Stop
Fan	Normal Control	Normal Control	Normal Control
Thermo On Unit EEV	Normal Control	400 ~ 800 Pulse	1,200 Pulse → 600 Pulse → Normal Control
Thermo Off Unit EEV	60 ~ 100 Pulse	400 ~ 800 Pulse	1,200 Pulse → 600 Pulse → 60 ~ 100 Pulse

- Start: Oil Return Operation will run every eight (8) hours.
- Oil Return Operation will run for three (3) minutes.
- Stop: Oil Return Operation will end if / when compressor protection control starts.

Defrost Control

Defrost Control

Defrost Control eliminates ice that has accumulated on the heat exchanger, recovering its performance. Each component operates as shown in the tables below during defrost.

Table 6: Outdoor Unit Defrost Control.

Component	Start	During Defrost Control Operation	Stop
Inverter Compressor	30Hz	Set Value	40Hz
Fan	Off	Normal Control	Off
Main EEV	300 Pulse	Maximum Pulse	200 Pulse
Subcooling EEV	Minimum Pulse	Minimum Pulse	Minimum Pulse
Four-Way Valve	On	On → Off → On	On
Hot Gas Bypass Valve (ARUN024~053GSS4 Heat Pump Units Only)	Normal Control	Normal Control	Normal Control

Table 7: Indoor Unit Defrost Control.

Component	Start	During Defrost Control Operation	Stop
Fan	Normal Control	Normal Control	Normal Control
Thermo On Unit EEV	Normal Control	400 ~ 800 Pulse	1,200 Pulse → 600 Pulse → Normal Control
Thermo Off Unit EEV	60 ~ 100 Pulse	400 ~ 800 Pulse	1,200 Pulse → 600 Pulse → 60 ~ 100 Pulse

Defrost Control Stop Operation

1. All heat exchanger pipe temperatures are above set temperatures for thirty (30) seconds.
2. Defrost Control Operation will run for >30% of the total heating time.
3. Defrost Control Operation will stop if / when compressor protection control starts (if a high discharge temperature at the compressor is detected).

Stop Operation Control

Stop Operation Control in Cooling Mode

Table 8: Stop Operation Control in Cooling Mode.

Component	Stop Operation	Notes
Inverter Compressor	0 Hz	-
Fan	Stop	-
Main EEV	Minimum Pulse	-
Subcooling EEV	Minimum Pulse	-
Four-Way Valve	Off	-
Hot Gas Bypass Valve (ARUN024~053GSS4 Heat Pump Units Only)	Off	After 15 Minutes (Before 15 Minutes: On)

Stop Operation Control in Heating Mode

Table 9: Stop Operation Control in Heating Mode.

Component	Stop Operation	Notes
Inverter Compressor	0 Hz	-
Fan	Stop	-
Main EEV	Minimum Pulse	-
Subcooling EEV	Minimum Pulse	-
Four-Way Valve	On → Off	One (1) Hour After Stop and Outdoor Temperature is >86°F → Off
Hot Gas Bypass Valve (ARUN024~053GSS4 Heat Pump Units Only)	Off	After 15 Minutes (Before 15 Minutes: On)

PROTECTION CONTROL



Pressure Protection Control

Heat Pump Units — ARUN024 ~ 053GSS4

Pressure Protection Control

Pressure Control in Cooling Mode

Table 10: Compressor High Pressure Control in Cooling Mode.

Pressure Range	Compressor
$P_d \geq 580.2$ psi	Stop
$P_d \geq 561.7$ psi	-5 Hz / 10 seconds
$P_d \geq 542.7$ psi	Frequency Hold*
$P_d \geq 528.5$ psi	+2 Hz or less / 10 seconds
$P_d < 528.5$ psi	Normal Control

Table 11: Fan High Pressure Control in Cooling Mode.

Pressure Range	Fan
$P_d \geq 580.2$ psi	Stop
$P_d \geq 547.5$ psi	+50 RPM / 10 seconds
$P_d \geq 518.9$ psi	RPM Hold*
$P_d < 518.9$ psi	Normal Control

* Frequency Hold = Frequency (or RPM) is not increasing (can decrease).

Table 12: Low Pressure Control in Cooling Mode.

Pressure Range	Compressor	Fan
$P_s \leq 23.6$ psi (one [1] minute later)	Stop	
$P_s \leq 27.6$ psi	-15 Hz / 10 seconds	-100 RPM / 10 seconds

Pressure Control in Heating Mode

Table 13: High Pressure Control in Heating Mode.

Pressure Range	Compressor	Fan
$P_d > 557.8$ psi	Stop	
$P_d \geq 509.5$ psi	-15 Hz / 10 seconds	-50 RPM / 10 seconds
$P_d \geq 481.1$ psi	Frequency Hold*	-50 RPM / 10 seconds
$P_d \geq 452.7$ psi	Frequency Hold*	RPM Hold*
$P_d < 452.7$ psi	Normal Control	

Table 14: Low Pressure Control in Heating Mode.

Pressure Range	Compressor	Fan
$P_s \leq 23.6$ psi (one [1] minute later)	Stop	
$P_s \leq 27.6$ psi	-15 Hz / 10 seconds	+100 RPM / 10 seconds
$P_s > 31.3$ psi	Frequency Hold*	+100 RPM / 10 seconds
$P_s \geq 34.1$ psi	+2 Hz or less / 10 seconds	+100 RPM / 10 seconds
$P_s \geq 37.0$ psi	Normal Control	

* Frequency Hold = Frequency (or RPM) is not increasing (can decrease).

Pressure Protection Control

Pressure Control in Cooling Mode

Table 15: High Pressure Control in Cooling Mode.

Pressure Range	Compressor	Fan
$P_d \geq 580.2$ psi	Stop	
$P_d > 547.5$ psi	-15 Hz / 10 seconds	+100 RPM / 10 seconds
$P_d \geq 518.9$ psi	Frequency Hold*	RPM Hold*
$P_d \geq 504.7$ psi	+2 Hz or less / 10 seconds	RPM Hold*
$P_d < 504.7$ psi	Normal Control	

Table 16: Low Pressure Control in Cooling Mode.

Pressure Range	Compressor	Fan
$P_s \leq 15.9$ psi	Stop (one [1] minute later)	Stop
$P_s \leq 21.8$ psi	-10 Hz / 10 seconds	-100 RPM / 10 seconds
$P_s > 21.8$ psi	Frequency Hold*	RPM Hold*
$P_s > 26.8$ psi	+2 Hz or less / 20 seconds	-100 RPM / 10 seconds
$P_s > 31.9$ psi	+2 Hz or less / 10 seconds	-100 RPM / 10 seconds
$P_s > 37.7$ psi	Normal Control	

* Frequency Hold = Frequency (or RPM) is not increasing (can decrease).

Pressure Control in Heating Mode

Table 17: High Pressure Control in Heating Mode.

Pressure Range	Compressor	Fan
$P_d \geq 580.2$ psi	Stop	
$P_d > 495.3$ psi	-15 Hz / 10 seconds	-50 RPM / 10 seconds

Table 18: Low Pressure Control in Heating Mode.

Pressure Range	Compressor	Fan
$P_s \leq 15.9$ psi	Stop (one [1] minute later)	Stop
$P_s \leq 21.8$ psi	-10 Hz / 10 seconds	+100 RPM / 10 seconds
$P_s > 21.8$ psi	Frequency Hold*	RPM Hold*
$P_s \geq 26.8$ psi	+2 Hz or less / 20 seconds	+100 RPM / 10 seconds
$P_s \geq 31.9$ psi	+2 Hz or less / 10 seconds	+100 RPM / 10 seconds
$P_s \geq 37.7$ psi	Normal Control	

* Frequency Hold = Frequency (or RPM) is not increasing (can decrease).

PROTECTION CONTROL



Discharge Temperature Control / Inverter Protection Control / Pressure Switch
Heat Pump Units — ARUN024 ~ 053GSS4

Discharge Temperature Control

Table 19: Outdoor Unit Discharge Temperature Control.

Temperature Range	Compressor	Subcooling EEV	Indoor Unit EEV
Tdis ≥ 239°F	Off	Minimum Pulse	Minimum Pulse
Tdis > 230°F	-5 Hz / 10 seconds	SC, SH Decrease Control	SH Decrease Control
Tdis < 230°F	-5 Hz / 30 seconds	SC, SH Decrease Control	SH Decrease Control
Tdis ≥ 221°F	No Increase	SC, SH Decrease Control	SH Decrease Control
Tdis ≤ 212°F	+3 Hz or less	SC, SH Decrease Control	SH Decrease Control
Tdis > 212°F	Normal Control	SC, SH Decrease Control	SH Decrease Control

* Frequency Hold = Frequency (or RPM) is not increasing (can decrease).

Tdis = Temperature Discharge.

SC = Subcooling.

SH = Superheating.

Inverter Protection Control for ARUN038 ~ 053GSS4 Only

Table 20: Discharge Temperature Control in Cooling Mode.

Current Type	Normal Operation	Frequency Will Drop	System Will Stop
AC Input Current	25A or less	27A or less	30A or less
Compressor Current	14A or less	15A or less	20A or less

Table 21: Discharge Temperature Control in Heating Mode.

Current Type	Normal Operation	Frequency Will Drop	System Will Stop
AC Input Current	25A or less	27A or less	30A or less
Compressor Current	14A or less	15A or less	20A or less

Pressure Switch

- There is a pressure sensor switch in series between the compressor and the power relay.
- The pressure sensor switch is normally On.

WARNING

The pressure sensor switch has small electric current from 220V AC. Never touch the connecting terminal nor short two wires. There is risk of fire, electric shock, and physical injury or death

Discharge Temperature Control / Inverter Protection Control / Pressure Switch
Heat Pump Unit — ARUN060GSS4, and Heat Recovery Unit — ARUB060GSS4

Discharge Temperature Control

Table 22: Outdoor Unit Discharge Temperature Control.

Temperature Range	Compressor	Subcooling EEV	Indoor Unit EEV
Tdis > 235.4°F	-5 Hz / 10 seconds	SC, SH Decrease Control	SH Decrease Control
Tdis > 230°F	-5 Hz / 30 seconds	SC, SH Decrease Control	SH Decrease Control
Tdis ≥ 221°F	Frequency Hold	SC, SH Decrease Control	SH Decrease Control
Tdis ≤ 212°F	+3 Hz or less	SC, SH Decrease Control	SH Decrease Control
Tdis > 212°F	Normal Control	SC, SH Decrease Control	SH Decrease Control

* *Frequency Hold = Frequency (or RPM) is not increasing (can decrease).*
Tdis = Temperature Discharge.
SC = Subcooling.
SH = Superheating.

Inverter Protection Control

Table 23: Discharge Temperature Control in Cooling Mode.

Current Type	Normal Operation	Frequency Will Drop	System Will Stop
AC Input Current	35A or less	36A or less	38A or less
Compressor Current	35A or less	36A or less	46A or less

Table 24: Discharge Temperature Control in Heating Mode.

Current Type	Normal Operation	Frequency Will Drop	System Will Stop
AC Input Current	25A or less	27A or less	30A or less
Compressor Current	14A or less	15A or less	20A or less

Pressure Switch

- There is a pressure sensor switch in series between the compressor and the power relay.
- The pressure sensor switch is normally On.

⚠ WARNING

The pressure sensor switch has small electric current from 220V AC. Ⓣ Never touch the connecting terminal nor short two wires. There is risk of fire, electric shock, and physical injury or death

Initial Setup

Initial Setup

There are four (4) initial setup steps before operation can begin. All DIP switch settings must be completed before initial setup.

Step 1

Factory set value is displayed on the PCB seven segment display (SSD) for twenty-four (24) seconds.

Turn power on.

Code for the outdoor unit is displayed for three (3) seconds.

07

Blank for six (6) seconds.

Total capacity is displayed for two (2) seconds.

10

System type is displayed.

- Heat Pump = 2 is default value.
- Heat Recovery = 3 is default value.

2

Electrical requirements are displayed.

- 208-230V = 22

22

Model Type.

1

Step 2

Communication Check: If display follows all sequences as shown above, communication is normal. If the SSD shows Error Code 104*, check the DIP switch settings and the communication cables on the outdoor unit.

Step 3

PCB Error Check: Error check will begin after forty (40) seconds.

Initial Setup, Continued.

Step 4: Indoor Unit Auto Addressing Procedure

⚠ WARNING

Disconnects must only be operated by a properly licensed electrician at this time. ⚠ Never look at a disconnect switch when closing. Turn away from the switch when closing. Incorrect wiring could cause the disconnect to explode, physical injury, and / or death.

Note:

- Supply power to the indoor units. If power is not supplied, an operation error will occur.
- During the pre-commissioning process for systems with Gen 4 indoor units, ⚠ do not change any DIP switch settings except for No. 3 on SW01B, which must be ON to enable Gen. 4 features. All other combinations of switches (one [1] through seven [7]) must be left in the OFF position on the outdoor unit DIP switch bank SW01B. Refer to System Combinations and Outdoor Unit Operation Settings for proper setting of No. 3 on SW01B.
- If the Auto Address Procedure has never been successfully completed for the system, the compressor(s) will not start when power is applied to the unit.
- Auto addressing is only possible on the main PCB of the outdoor unit.

1. Verify all that all indoor units connected to the system have power to the PCB board AND all zone controller system start buttons are OFF.
2. Remove the maintenance access panel and unit control box cover from the outdoor unit. Place panels and screws in a secure area.
3. Verify that the communications cable between the indoor units and the outdoor unit is terminated at the outdoor unit terminals IDU(A) and IDU (B).
4. Verify the shield on the communications cable is grounded at the outdoor unit.
5. Check if all DIP switches are set to OFF.
6. Cycle power on the outdoor units, indoor units, etc., and wait three (3) minutes while the outdoor unit sequences through the self-diagnostics check, and to improve indoor unit communication when initial power is supplied. Leave disconnect in the "ON" position.
7. Check the outdoor unit(s) current configuration code(s). Observe the unit setup codes using the LED display found on the outdoor units PCB. Each code will display for two (2) seconds.

Note:

After the self-diagnostics check is complete, the LED must be clear and nothing displayed. Diagnostic process must take from three (3) to seven (7) minutes.

8. Know how many indoor units are connected to the system.
9. Press and hold the red SW01C button for about five (5) seconds. Release when "88" appears on the LED. After three (3) to seven (7) minutes, the display will flash a number for about ten (10) to thirty (30) seconds indicating how many indoor units the system successfully communicated with.
10. This number must match the known installed number of indoor units if the auto addressing procedure was successful. If using LGMV, read the address of each indoor unit. The address of each indoor unit is also indicated on wired remote control displays.
11. Upon completion of the auto addressing routine, the display will be blank and the system will be in standby waiting for another command.

Initial Setup

Initiate the Auto Addressing Procedure, continued.

12. Upon successful completion of the auto address procedure, record the system address assigned to each indoor unit by the auto address procedure in the column provided on the Pre-commissioning Device Configuration Worksheet.

13. After recording the system addresses assigned to each device, open the outdoor unit disconnect. Remove the outdoor unit to indoor unit communications cable from terminals IDU(A) and IDU(B). Protect conductors by placing electrical tape over the bare ends.

14. Close the disconnect to reapply power to the outdoor unit and energize the compressor crankcase heater. Once again, verify that the outdoor unit to indoor unit(s) communications cable is not connected to terminals IDU(A) and IDU(B) of the outdoor unit.

15. Replace the control panel door.

Figure 3: Auto Address Button Location on ARUN24-53GSS4 Outdoor Unit PCB.

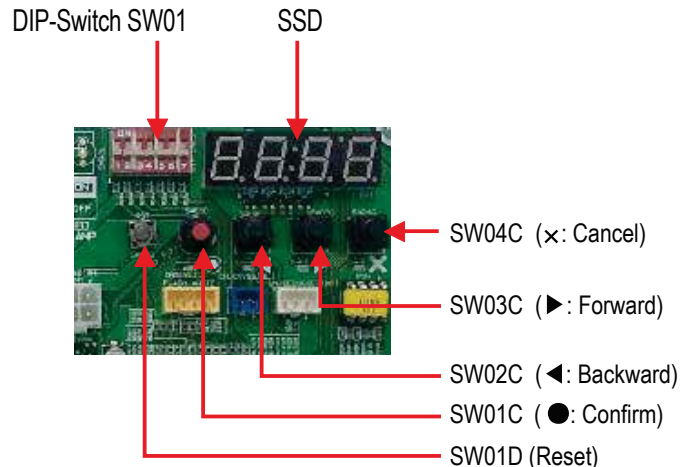

Figure 4: Auto Address Button Location on ARUN60GSS4 and ARUB60GSS4 Outdoor Unit PCB.

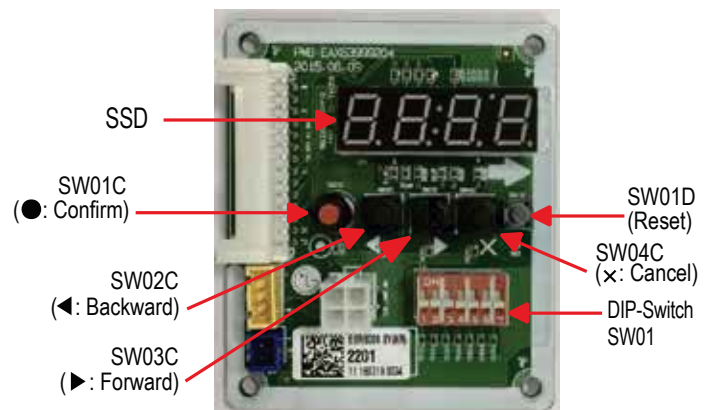
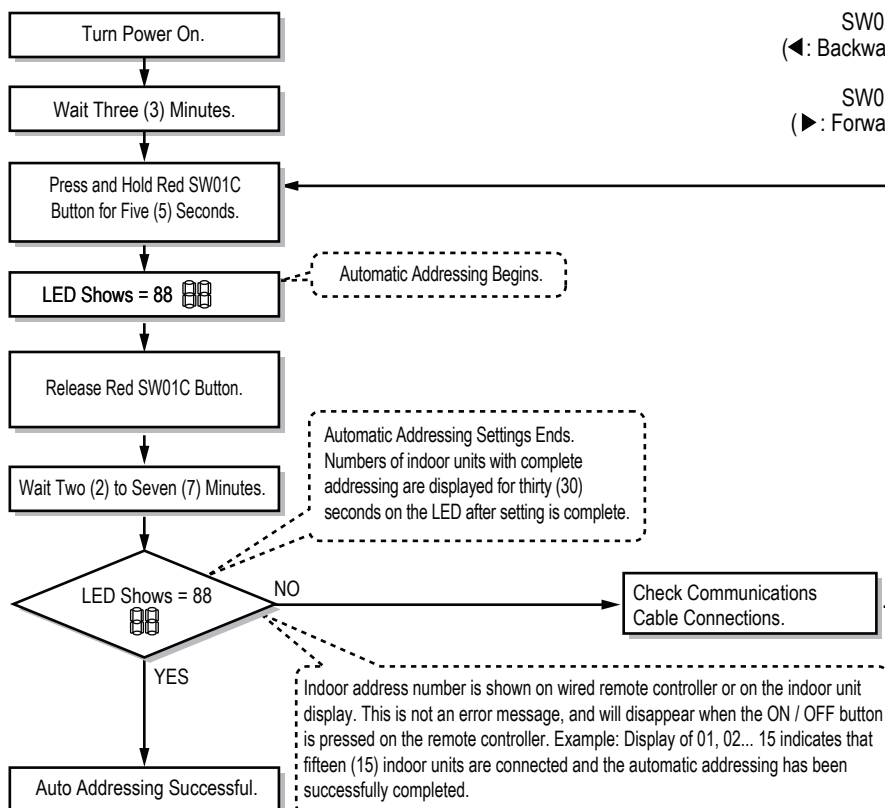

Figure 5: Indoor Unit Auto Addressing Procedure Flowchart.



⚠ WARNING

Upon successful completion of the auto addressing function, an unintentional compressor start can occur unless the communications cable to the indoor units is removed from the outdoor unit terminals IDU(A) and IDU(B). Do NOT open the service valves or attempt to start outdoor unit compressors or until directed by the LG trained Commissioner. Major damage to the unit piping and compressors will occur, and there is a risk of explosion, suffocation, physical injury, and / or death.

Troubleshooting a Failed Indoor Unit Auto Addressing Procedure

Note:

If the quantity of indoor units the auto addressing procedure found is incorrect, or the “88” never disappears from the display for the seven (7) minutes, the auto address routine has failed and a communications problem exists. If the Auto Address Procedure failed:

1. Verify ALL indoor unit ON / OFF buttons are in the OFF position (i.e., ON / OFF button NOT illuminated).
2. Check the terminations, polarity, and continuity of each conductor on the communications cable between the outdoor unit and the indoor units. Verify the indoor unit to outdoor unit communications cable is wired correctly.
3. Verify the shield of the communications cable is grounded at the outdoor unit only. All segment shields must be spliced together at each indoor unit and  NOT grounded.
4. After repairing the communications cable, go to Step 9 of the Initiate the Auto Addressing Procedure and repeat the process until successful: Press and hold the red SW01C button for about five (5) seconds. Release when “88” appears on the LED. After three (3) to seven (7) minutes, the display will flash a number for about thirty (30) seconds indicating how many indoor units the system successfully communicated with.
5. This number must match the known installed number of indoor units if the auto addressing procedure was successful.
6. Upon completion of the auto addressing routine, the display will be blank and the system will be in standby waiting for another command.
7. Record the system address the outdoor unit assigned to each indoor unit by the auto address procedure in the column provided on the Pre-commissioning Device Configuration Worksheet.
8. After recording the system addresses assigned to each device, open the outdoor unit disconnect. Remove the outdoor unit to indoor unit communications cable from terminals IDU(A) and IDU(B). Protect conductors by placing electrical tape over the bare ends to prevent an accidental compressor start from occurring before the LG trained Commissioner arrives.
9. Close the disconnect to reapply power to the outdoor unit and energize the compressor crankcase heater. Once again, verify the outdoor unit to indoor unit(s) communications cable is not connected to terminals IDU(A) and IDU(B) of the outdoor unit.
10. Replace the control panel cover.

OTHER CONTROLS

Setting Optional Modes

Setting the Functions

To access and set the different modes/functions, first turn No. 5 on DIP Switch SW01 is set to ON. Then select the functions (mode, option, value, etc.) by using the SW03C forward ► button and the SW02C backward ◀ buttons. Choose the particular function by pushing the confirm ● button.

Note:

- To set the optional modes / functions, all indoor units must be OFF. Mode / function settings won't save, nor will operate unless all indoor units are OFF.
- If system power was reset, some modes / function settings will be automatically saved in the EEPROM. Other modes / functions will reset when power is cycled off. See next pages for details on specific modes / functions.

Figure 6: Outdoor Unit DIP Switch SW01 Function Setting.

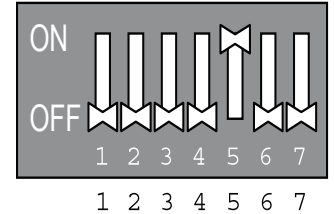

Figure 7: Location of DIP Switches and Setting Buttons on the ARUN24~53GSS4 Outdoor Unit PCB.

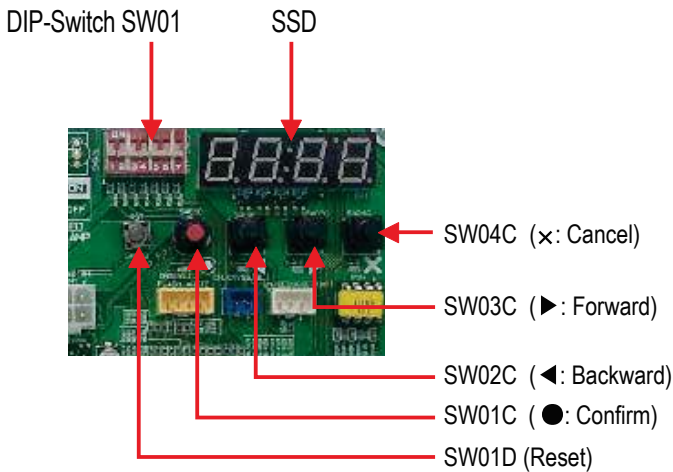

Figure 8: Location of DIP Switches and Setting Buttons on the ARUN60GSS4 and ARUB60GSS4 Outdoor Unit PCB.

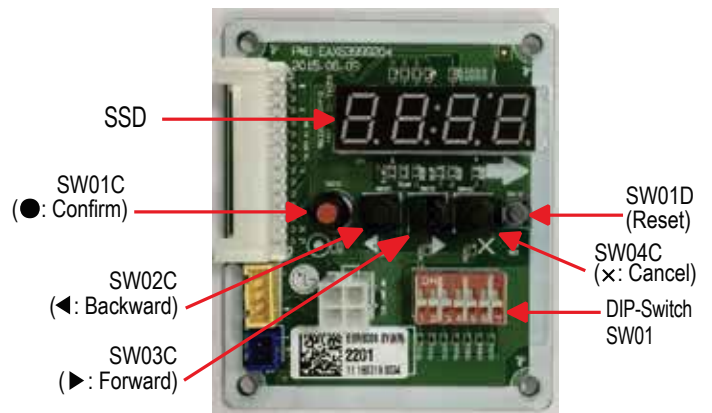

Table 25: Setting the Functions.

Mode Selection		Selection		Selection		Notes
Content	Display	Mode / Function Name	Display	Default	Options	
Function	Func	Cool / Heat Selector	Fn1	oFF	oFF, oP1 ~ oP2	Saved in EEPROM.
		Static Pressure Compensation	Fn2	oFF	oFF, oP1 ~ oP2	Saved in EEPROM.
		Night Low Sound	Fn3	oFF	oFF, oP1 ~ oP15	Saved in EEPROM.
		Outdoor Unit Addressing	Fn5	0	0~254	Saved in EEPROM.
		Snow Removal Assist / Rapid Defrost	Fn6	oFF	oFF, oP1~oP3	Saved in EEPROM.
		Adjusting Target Pressure	Fn8	oFF	oFF, oP1~oP6	Saved in EEPROM.
Service	Svc	Pump Down	SE1, Pd	Pd	-	
		Vacuum Mode	SE3, vAcc	vAcc	-	One Time / One Selection
		Forced Oil Return	SE5, 01	oFF	on, oFF	
		Forced Defrost	SE6, dEF	oFF	on, oFF	
		Cycle Data View	SE7 or 8 (depends on model)	oFF	on, oFF, oP1~oP26	Shows each cycle value in real time.
		Refrigerant Sound Reduction Mode	SE8 or 9 (depends on model)	oFF	on, oFF, oP1~oP2	Saved in EEPROM.

Cool / Heat Selector (Fn1)

The setting communicates to the outdoor unit that the optional LG Cool / Heat Selector (or appropriate field-provided relays and wiring that perform the same task) is connected to the system. The Cool / Heat Selector is field-wired to the “Dry 1” and “Dry 2” terminals located on the master outdoor unit main PCB.

The Cool / Heat Selector has two switches. The two-position upper switch manually locks out heating and cooling operation, allowing fan only, or heating or cooling operation depending on the position of the lower switch. The two-position bottom switch manually sets the position of the outdoor unit’s reversing valve. If the left side is depressed, the valve is in the cooling position. If the right side is depressed, the valve is in the heating position. The Cool / Heat Selector also provides a method for locking out compressor operation by placing the “Fan Only” toggle switch in the “On” position.

- Off (Default): No Cool / Heat Selector installed, or the Cool / Heat Selector is installed, but has not been identified by the master outdoor unit.
- On: Cool / Heat Selector installed and operational. When On is selected:
 - The left side of the upper switch is depressed. Mechanical refrigeration is locked out and the indoor unit fans are allowed to operate. The position of the lower switch is irrelevant.
 - The right side of the upper switch is depressed, the lower switch has the right side depressed, and the system is operating in cooling.
 - The right side of the upper switch is depressed, the lower switch has the left side depressed, and the system is operating in heating.

Use the Cool / Heat Selector in heat pump systems to set the system mode for all cooling operation, all heating operation, fan only, or dry operation (when all indoor units have to be in the same mode).

For use in heat pump systems only.

Figure 9: Cool / Heat Selector.

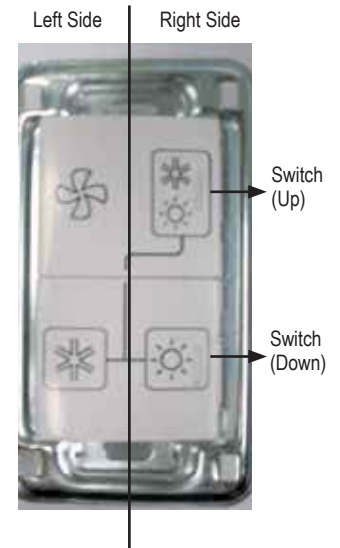
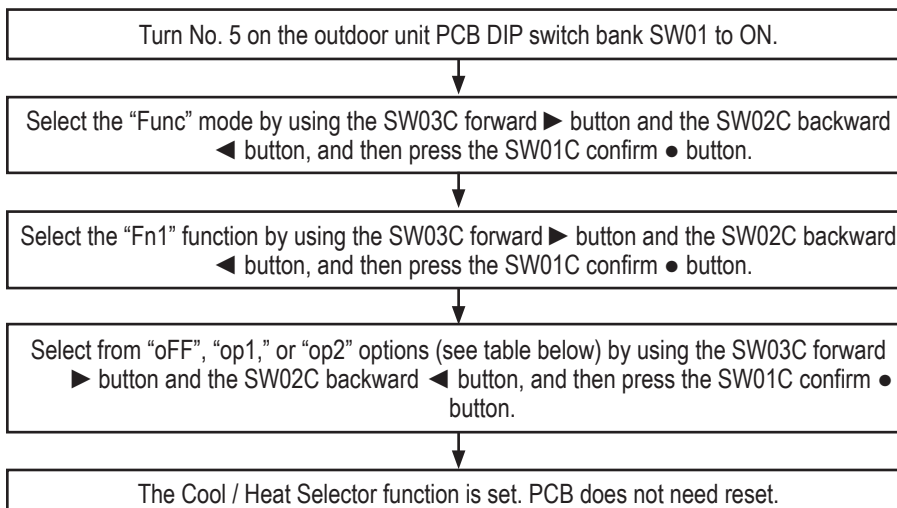

Figure 10: Setting the Cool / Heat Selector Function.



Note:

- The Cool / Heat Selector must be installed first before setting the cool / heat operation function.
- A trained LG service provider must set this function during system installation.
- If cool or heat function is not used, set to OFF.
- Cool / Heat Selector is flagged as the master on the central control communications bus.
- Cool / Heat Selector is not for use with BMS Gateway, VMS, or VMS Communications Manager.

Table 26: Cool / Heat Selector Function Settings.

Switch Control		Function		
Switch (Up)	Switch (Down)	oFF	op1 (Mode)	op2 (Mode)
Right Side (On)	Left Side (On)	Not Operating	Cooling	Cooling
Right Side (On)	Right Side (On)	Not Operating	Heating	Heating
Left Side (Off)	-	Not Operating	Fan Mode	Off

OTHER CONTROLS

Setting Optional Modes

Static Pressure Compensation Function (Fn2)

Static Pressure Compensation function modifies the maximum outdoor unit fan speed during normal system operation. Use the function to raise the maximum outdoor unit fan speed to compensate for an obstruction (duct) in airflow.

Refer to the Multi V Engineering Manuals for the default static pressure rating, and the maximum static pressure rating with this function engaged.

Note:

- Ask a trained LG service provider to set this function during system installation.
- Cooling capacity can be reduced if the outdoor unit RPM is lowered.

Table 27: Setting Static Pressure Compensation Function.

Model	ARUN060GSS4 ARUN053GSS4, ARUN048GSS4, ARUN038GSS4	
Maximum RPM	oFF (Standard)	800
	op1	850
	op2	850

Figure 11: Setting the Static Pressure Compensation Function.

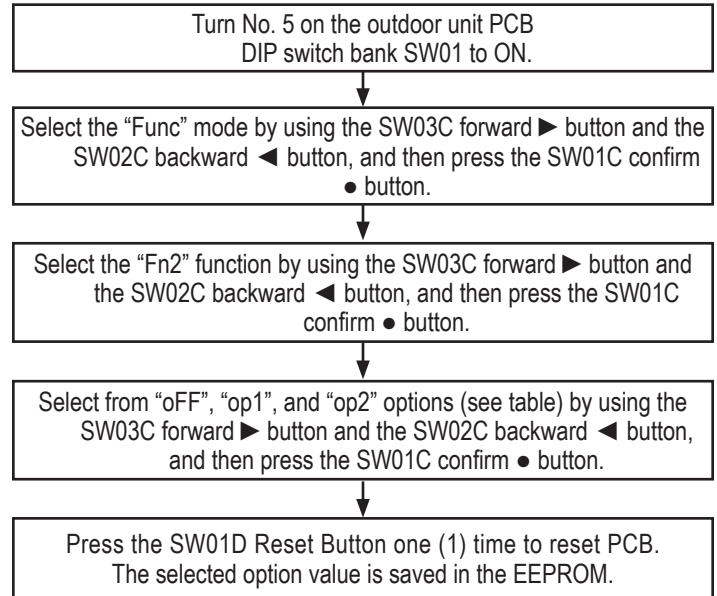

Night Low Sound Function (Fn3)

The Night Low Sound Function reduces the operating speed of the outdoor unit fans (according to the input signal) during “off-peak” hours under normal circumstances when in cooling mode. Operating at a low RPM reduces the fan sound levels of the outdoor unit at night (or other off-peak hours), which usually has a low cooling load.

On a rolling 24 hour basis, an internal timer begins counting hours after the start time (delay set after peak cooling recorded operation), switching to restricted fan speed duration operation, following whatever settings have been chosen.

For use on both heat pump and heat recovery systems.

- Timed algorithm. Restricted fan speed period length and start delay is selectable.
- Delay timer starts each day when, during a one (1) minute period the highest demand for cooling is recorded by the outdoor unit.
- Request servicer to set the function during installation.
- If the function is not used set the DIP switches to OFF and reset the power.
- If the outdoor unit Hz and rpm change, cooling capacity can decrease.

Figure 12: Setting the Night Low Sound Function.

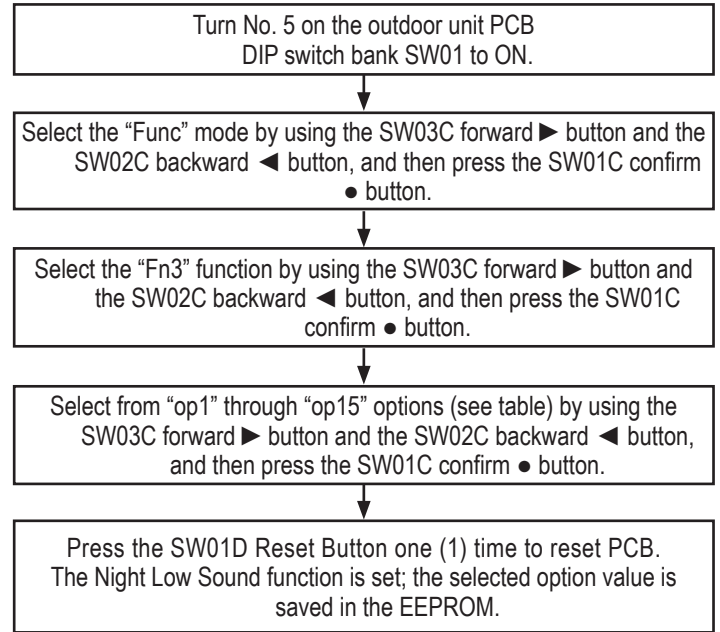

Table 28: Setting the Time and Related Sound Level.

Settings	Start Time (Delay after Peak Cooling Recorded) (Hour)*	Restricted Fan Speed Duration (Hour)
op1	8.0	9.0
op2	6.5	10.5
op3	5.0	12.0
op4	8.0	9.0
op5	6.5	10.5
op6	5.0	12.0
op7	8.0	9.0
op8	6.5	10.5
op9	5.0	12.0
op10 (Default)	Continuous Operation	
op11		
op12		
op13	6.5	10.5
op14	6.5	10.5
op15	6.5	10.5

*The system measures ambient temperature (minimum and maximum) in “Wait Time” to help determine when the system can start operating in Night Low Sound.

Outdoor Unit Addressing Function (Fn5)

Use this function to set addresses when more than one Multi V system shares a communications bus linked to a central controller or BMS gateway. Each system is assigned to a unique outdoor unit address. The Outdoor Unit Addressing Function will help avoid assigning the same address to the different systems; if not properly addressed, a communication error could occur on one (1) or more of the systems.

For use on both heat pump and heat recovery systems.

- 000 = Default; Central Control Address setting of "000".
- 001 = Central Control Address setting of "001".
- Set 1 of 255 Valid Addresses; 000, 001, 002, 003, 004...through 254.

Note:

- *The central controller or BMS gateway must be installed first before setting the outdoor unit address.*
- *A trained LG service provider must set this function during system installation.*

Figure 13: Setting the Outdoor Unit Address Function.

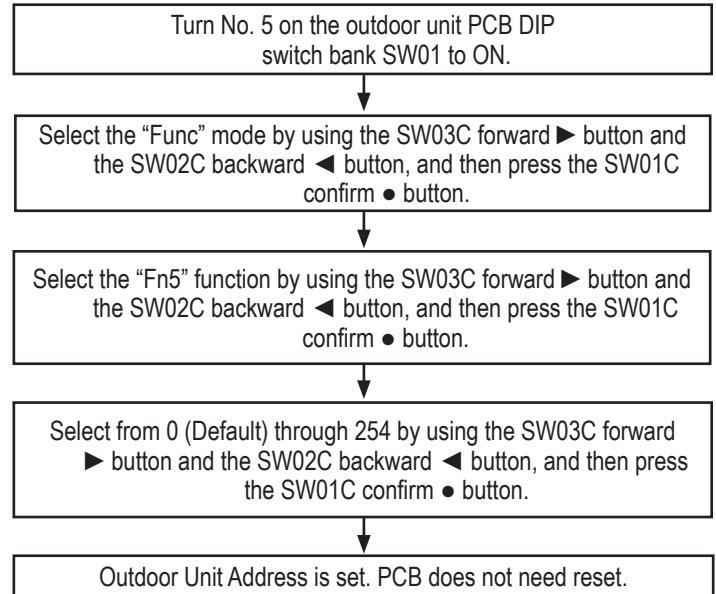

Snow Removal Assist / Rapid Defrost Function (Fn6)

Snow Removal Assist

Snow Removal Assist function allows the outdoor unit(s) fans to operate at regular intervals, for two (2) minutes, at specified speeds (as seen in the tables below) to remove snow accumulation from the fan discharge.

The function will only operate when the system has not called for compressor activity (no demand for heating or cooling) for thirty (30) minutes, and when the outdoor air temperature is <37°F. Operates every thirty (30) minutes for two (2) minutes. Function will stop if there is an operation error code, or if a compressor starts. Use this function in areas where snow accumulating on the fan blades and fan guard is common.

Rapid Defrost

Rapid Defrost function limits the amount of frost and ice are allowed to build on the coil between defrost cycles (defrost cycles occur more often). System pressure is monitored, and when system pressure is reduced, the defrost cycle is initiated.

Snow Removal Assist and Rapid Defrost can be used on both heat pump and heat recovery systems.

Snow Removal Assist / Rapid Defrost can also be used with Forced Defrost - SE6.

Table 29: Setting the Snow Removal / Rapid Defrost Function.

Settings	Details
oFF (Default)	Mode Is Not Set
op1	Snow Removal Assist Mode
op2	Rapid Defrost Mode
op3	Snow Removal Assist Mode and Rapid Defrost Mode

Figure 14: Setting the Snow Removal / Rapid Defrost Function.

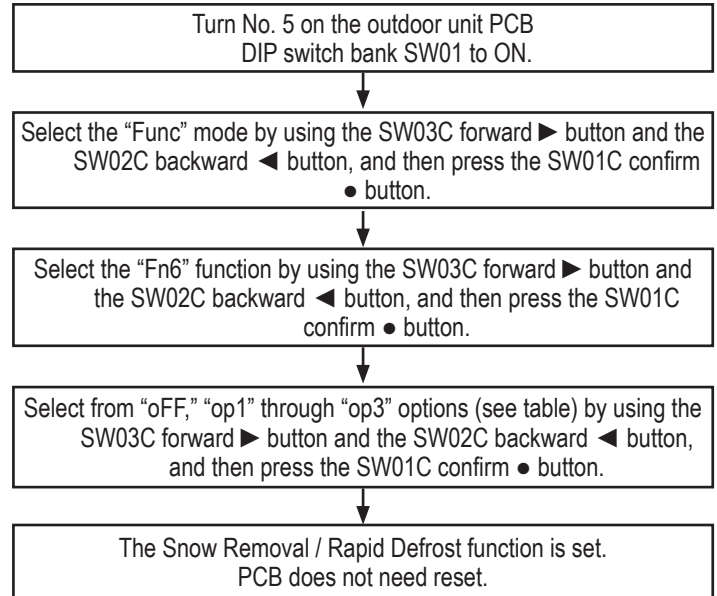

Note:

- A trained LG service provider must set this function during system installation.
- If the snow removal / rapid defrost mode is not used, set to OFF.

Setting Optional Modes

Adjusting Target Pressure (Fn8)

The Adjusting Target Pressure function modifies the refrigeration cycle's high and low pressure target values; more specifically, modifies the compressor discharge and suction target operating pressure values. Can be used to enhance / turn down the cooling or heating capabilities of variable refrigerant flow systems, optimizing refrigeration cycle operation to maximize operational efficiency.

Separate, unique setting values can be assigned for cooling, and heating operation.

For use on both heat pump and heat recovery systems.

Figure 15: Adjusting Target Pressure Function.

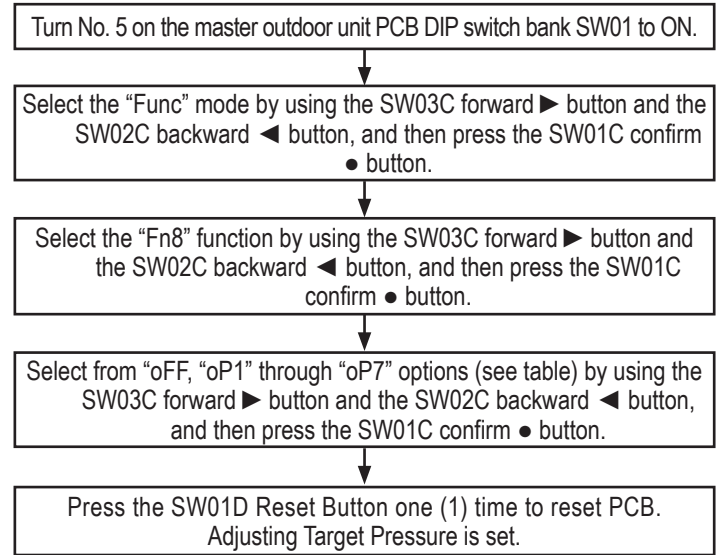

Table 30: Setting Adjusting Target Pressure Function.

Setting	Low Pressure Vapor Target psig / kPa (°F)	High Pressure Vapor Target psig / kPa (°F)
oFF (Default)	117 / 804 (39.5)	434 / 2,990 (122.8)
oP1	105 / 725 (34.0)	453 / 3,121 (126.1)
oP2	111 / 765 (37.0)	443 / 3,056 (124.5)
oP3	126 / 869 (43.5)	410 / 2,827 (118.5)
oP4	136 / 935 (47.5)	386 / 2,663 (114.1)
oP5	145 / 1,000 (51.0)	363 / 2,500 (109.5)
oP6	154 / 1,065 (54.3)	339 / 2,337 (104.8)
oP7	117 / 804 (39.5)	434 / 2,990 (122.8)

Pump Down for Heat Pump Outdoor Units (SE1, Pd)

Pump Down function gathers the refrigerant in the system, and sends it to the outdoor unit. Use Pump Down function when there is a refrigerant leak, or if an indoor unit needs to be replaced. The maximum refrigerant for outdoor units is size dependent and varies. If the system charge is greater than the volume that can be stored, a supplemental vacuum pump and third-party storage containers will be required. For use on both heat pump and heat recovery systems.

Table 31: Setting the Pump Down Function.

Settings	Function
oFF (Default)	Pump Down is not enabled.
Pd (on)	Pump Down is enabled. Display Will Show Low Pressure.

Outdoor Unit Functions

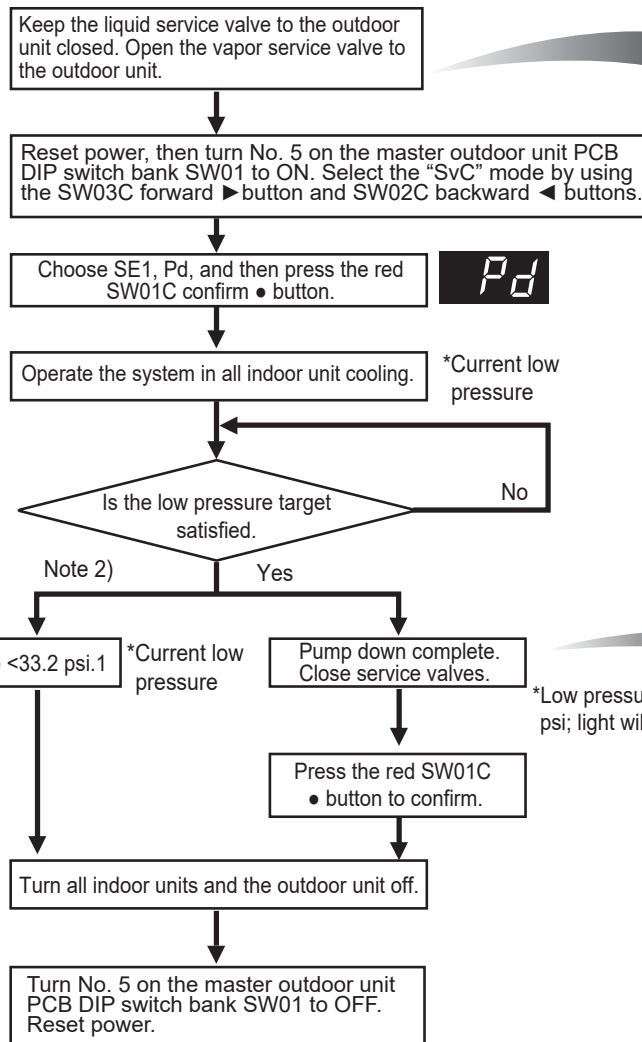

Outdoor Unit Service Valves for Heat Pump System Pump Down

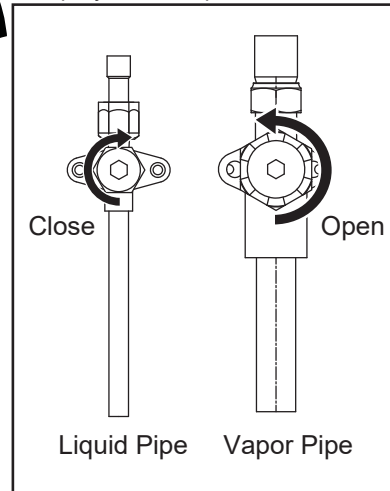

Outdoor Unit Service Valves for Heat Pump System After Pump Down Is Finished

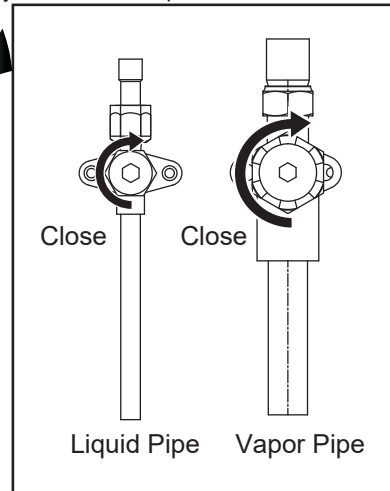

Note:

1. If low pressure falls below 33.2 psi, immediately close the vapor service valves. (See figures above.)
2. If low pressure falls below 44.5 psi (light will blink), the system will shut off automatically. Immediately close the vapor service valve.

Note:

- Use the Pump Down function while ambient conditions are within the manufacturer's operating temperature ranges: Indoor Units = 68~89.6°F; Outdoor Units = 41~104°F.
- Do not run the indoor units in thermo off mode during Pump Down.
- Maximum operation time of Pump Down is thirty (30) minutes (in case low pressure does not satisfy target levels immediately).

OTHER CONTROLS

Setting Optional Modes

Pump Down for Heat Recovery Outdoor Units (SE1, Pd)

Pump Down function gathers the refrigerant in the system, and sends it to the outdoor unit. Use Pump Down function when there is a refrigerant leak, or if an indoor unit needs to be replaced. The maximum refrigerant for outdoor units is size dependent and varies. If the system charge is greater than the volume that can be stored, a supplemental vacuum pump and third-party storage containers will be required. For use on both heat pump and heat recovery systems.

Table 32: Setting the Pump Down Function.

Settings	Function
oFF (Default)	Pump Down is not enabled.
Pd (on)	Pump Down is enabled. Display Will Show Low Pressure.

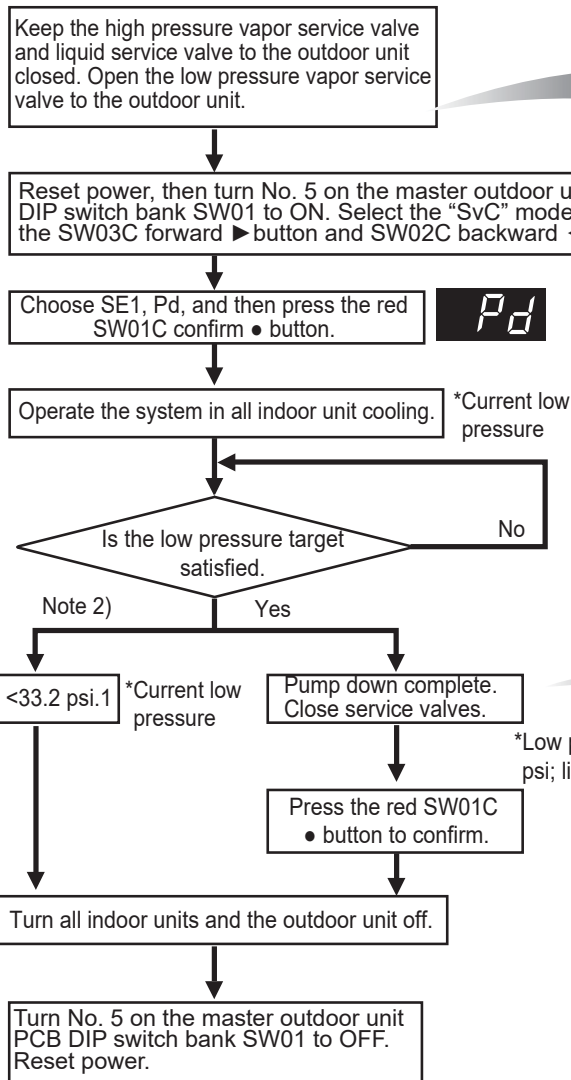

Outdoor Unit Service Valves for Heat Recovery System Pump Down

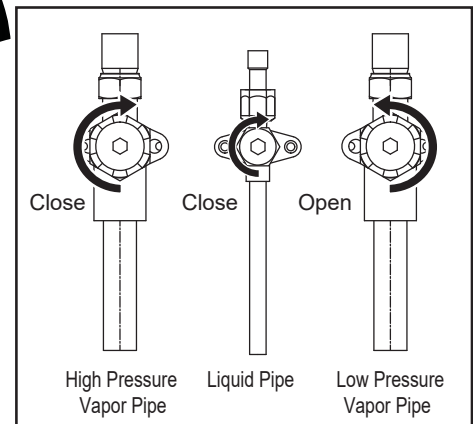

Outdoor Unit Service Valves for Heat Recovery System Pump Down

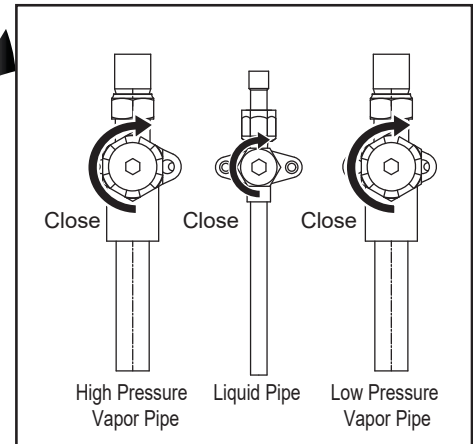

Note:

1. If low pressure falls below 33.2 psi, immediately close the vapor service valve. (See figures above.)
2. If low pressure falls below 44.5 psi (light will blink), the system will shut off automatically. Immediately close the vapor service valve.

Note:

- Use the Pump Down function while ambient conditions are within the manufacturer's operating temperature ranges: Indoor Units = 68~89.6°F; Outdoor Units = 41~104°F.
- Do not run the indoor units in thermo off mode during Pump Down.
- Maximum operation time of Pump Down is thirty (30) minutes (in case low pressure does not satisfy target levels immediately).

Vacuum Mode (SE3, vAcc)

The vacuum mode can be used as an option for creating vacuum in the system when the outdoor unit is first installed, if power is available, and if the system has already been auto addressed. Vacuum mode enables the system to fully open all valves, and can help speed up the evacuation process.

Vacuum mode can also be used when compressor and / or outdoor unit parts are replaced, or when an indoor unit is added or replaced.

1. Turn No. 5 on the outdoor unit PCB DIP Switch SW01 to ON.
2. Select the "SvC" mode By using the ► and ◀ buttons, then push the ● button.
3. Select the "SE3" function By using the ► and ◀ Buttons, then push the ● button.
4. Press the SW01D Reset Button one (1) time to reset PCB, and start the vacuum mode "vACC". In vacuum mode, the outdoor unit valve is open, the outdoor unit EEV is open, and the indoor unit(s) EEV(s) is/are open. The heat recovery unit(s) valve(s) and EEVs are open (if system is a heat recovery system).
5. To cancel the vacuum mode, turn No. 5 on the outdoor unit PCB DIP Switch SW01 to OFF, and push the SW01D reset button on the outdoor unit PCB.

Figure 16: Vacuum Mode DIP Switch.

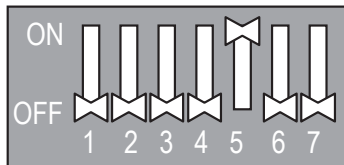

Setting Vacuum Mode

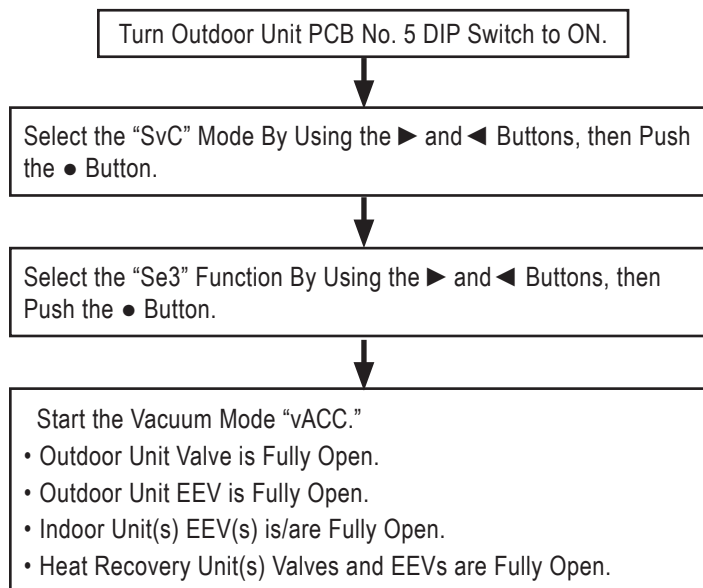

Figure 17: Location of DIP Switches and Setting Buttons on the ARUN24~53GSS4 Outdoor Unit PCB.

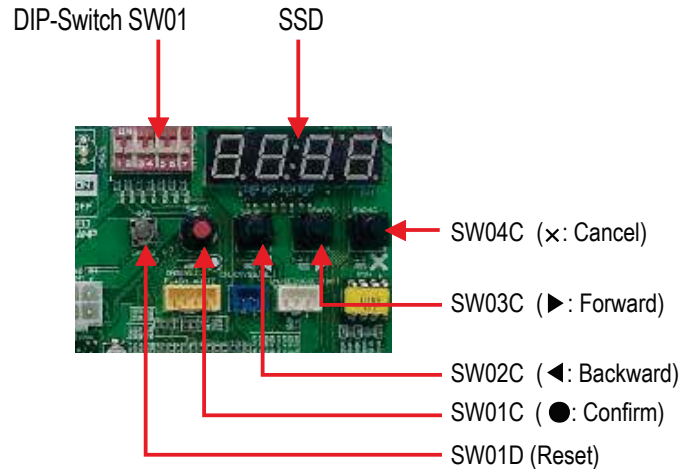
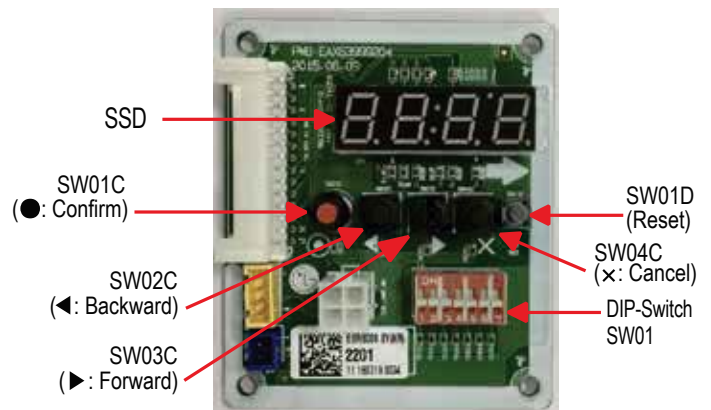

Figure 18: Location of DIP Switches and Setting Buttons on the ARUN60GSS4 and ARUB60GSS4 Outdoor Unit PCB.



Canceling Vacuum Mode

Turn on Outdoor Unit.
<AND>
Push the Reset Button on the Outdoor Unit PCB. On a Multi-Frame System, Push the Reset Button on ALL Outdoor Units.

Note:

- Outdoor unit operation stops during Vacuum Mode, so the compressor cannot operate.
- Limit vacuum mode to less than 48 hours of continuous operation. If vacuum mode is not stopped, the system will continue to operate with all EEVs and valves open on the non-vacuum mode terminated slave outdoor units. The refrigerant will flood back to the compressors on those non-vacuum mode terminated slave outdoor units, which will result in poor operation, equipment malfunction and / or compressor damage.

OTHER CONTROLS

Setting Optional Modes

Forced Oil Return (SE5, 01)

The Forced Oil Return function overrides LG's Smart Oil Management algorithm, replacing it with a timed oil return that initiates every fifteen (15) minutes when the sensor indicates the oil level is low. Use the function in applications where oil return has been problematic, a compressor failed due to low oil and the cause is unknown.

For use on both heat pump and heat recovery systems.

Table 33: Setting Forced Oil Return Function.

Settings	Function
oFF (Default)	Forced Oil Return is Disabled.
01	Forced Oil Return is Enabled. Oil Return Occurs Every Fifteen (15) Minutes When Low.

Forced Defrost (SE6, dEF)

The Forced Defrost function overrides LG's defrost algorithm when the outside ambient air temperature is <14°F, occurring every three (3) hours irrelevant of need. Use the function when defrost at low ambient temperatures does not completely clear the coil, and the frost that remains impacts comfort levels. It can also be used on installations where the outdoor unit heating capacity needs to be optimized at all times during low ambient operation to maintain comfort.

For use on both heat pump and heat recovery systems.

Forced Defrost can also be used with Fn6 - Snow Removal Assist / Rapid Defrost (oP2 or oP3).

Table 34: Setting Forced Defrost Function.

Settings	Function
oFF (Default)	Forced Defrost is Disabled.
dEF	Forced Defrost is Enabled. Oil Return Occurs Every Three (3) Hours Irrelevant of Need.

Figure 19: Setting the Forced Oil Return Function.

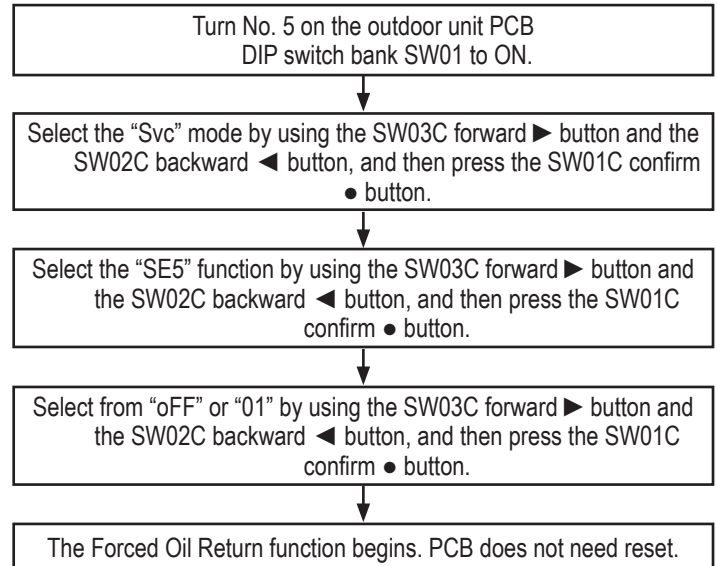
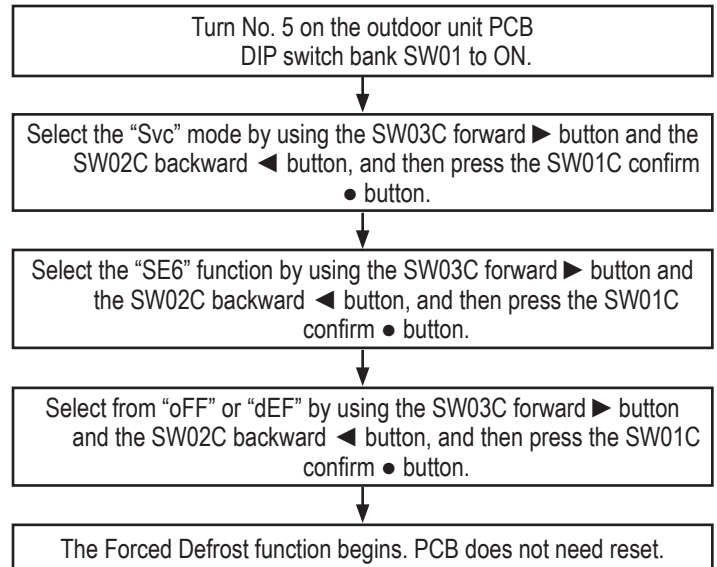

Figure 20: Setting the Forced Defrost Function.



Cycle Data View (SE7 or SE8 [Depends on Model])

Cycle Data View displays the cycle data of the operating outdoor unit. Cycle Data View can display up to 26 different cycle datapoints (depending on the outdoor unit) on the SSD.

For use on both heat pump and heat recovery systems.

Figure 21: Setting the Cycle Data View Function.

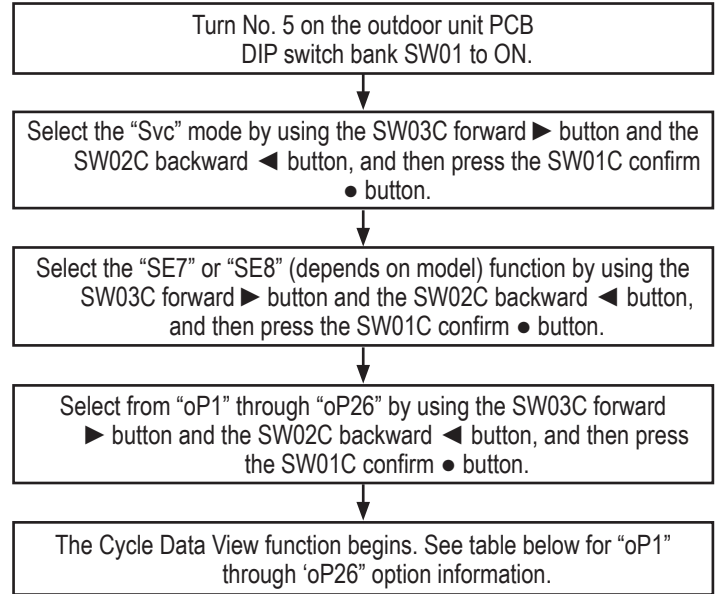

Table 35: Cycle Data View Datapoint Options.

Option	Description	Display	Example	seg_1	seg_2	seg_3	seg_4
op1	Current High Pressure	P1	4,321 kPA (626.7 psi)	4	3	2	1
op2	Current Low Pressure	P2	1,234.2 kPA (179 psi)	1	2	3	4
op3	Inverter Compressor	h1	120 Hz		1	2	0
op4	Fan 1	h3	110 rpm		1	1	0
op5	Fan 2	h4	110 rpm		1	1	0
op6	Degree of Superheating	T1	53°C (127.4°F)		5	3	0
op7	Degree of Subcooling	T2	-4.5°C (23.9°F)	-		4	5
op8	Outdoor Unit Temperature	T3	10°C (50°F)		1	0	0
op9	Suction Temperature	T4	43.4°C (110.1°F)		4	3	4
op10	Compressor Discharge Temperature	T5	150°C (302°F)	1	5	0	0
op12	Liquid Pipe Temperature	T7	10°C (50°F)		1	0	0
op14	Sc_out	T9	10°C (50°F)		1	0	0
op15	Hex	T10	10°C (50°F)		1	0	0
op18	Inlet Pipe Temperature of Indoor Unit	T13	-10°C (14°F)	-	1	0	0
op19	Main EEV	PLS1	1,950	1	9	5	0
op21	SC EEV	PLS3	16			1	6
op25	Operation Capacity of Indoor Units	IDU1	24,000			2	4
op26	Total Number of Indoor Units	IDU2	10			1	0

OTHER CONTROLS

Setting Optional Modes

Refrigerant Sound Reduction Mode (SE8 or SE9 [Depends on Model])

This function reduces refrigerant flow sound in the liquid piping caused by mixed-state refrigerant by adjusting air flow across the outdoor unit coil. It reduces the refrigerant flow sound at all indoor units when system is operating in heating or cooling. The function will impact all indoor units; selective indoor unit application is not possible.

In cooling, when the compressor speed remains constant, reducing the airflow over the outdoor unit coil raises head pressure and sub-cooling. Increased subcooling reduces the possibility that gas bubbles will form in the liquid line before reaching the indoor unit EEVs.

In heating, when the compressor speed remains constant, the temperature of the superheated gas leaving the compressor and entering the indoor coil is reduced. This results in slightly less heating performance, but sub-cooling rises in the liquid leaving the indoor (condenser) coil. More sub-cooling keeps gas bubbles from forming before the liquid passes through the condenser coil EEV valve.

For use on both heat pump and heat recovery systems.

Note:

- Because of the restricted refrigerant flow, it will take longer to preheat the coil on startup.
- An incorrect charge can result in refrigerant flow related sound. Verify the system's refrigerant charge is correct before using this function.
- Ask a trained service provider to set this function.
- Power consumption or efficiency will change if the Refrigerant Sound Reduction Mode is set.

Table 36: Setting the Refrigerant Sound Reduction Function for Multi V S 24-53K Heat Pump Systems.

Settings	Function
oFF	Refrigerant Noise Reduction Mode is Disabled
on	Refrigerant Noise Reduction Mode is Enabled

Figure 22: Setting the Refrigerant Sound Reduction Function.

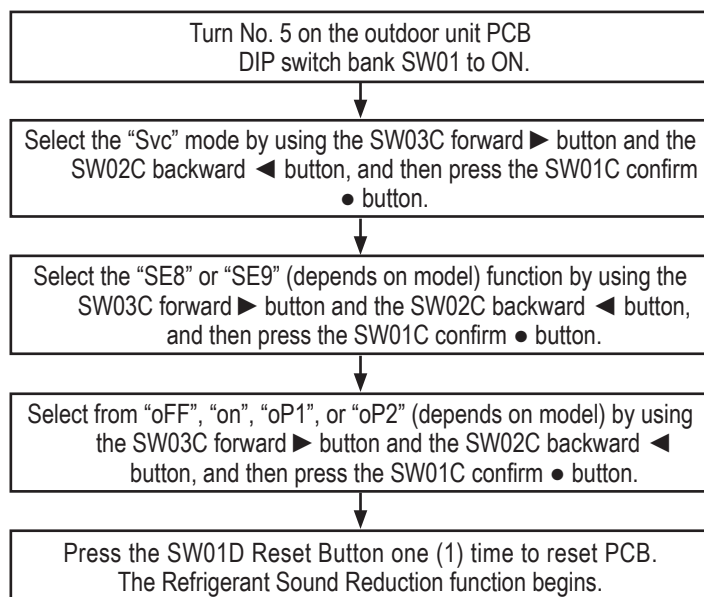

Table 37: Setting the Refrigerant Sound Reduction Function for Multi V S 60 Heat Pump and Heat Recovery Systems.

Setting	Function
oFF	Fast Cooling and Fast Heating
oP1	Strong Refrigerant Noise Reduction Mode
oP2	Mild Refrigerant noise reduction Mode

Table 38: Heat Recovery Unit Parts Table.

Name	Symbol	Function
Low Pressure Vapor Pipe	LPGV	Pipe for Low Pressure Vapor
High Pressure Vapor Pipe	HPGV	Pipe for High Pressure Vapor
Liquid Pipe 1	LP1	Liquid Pipe to the Outdoor Unit(s)
Liquid Bypass Valve	LBV	Prevents Liquid Charge
Solenoid Assembly 1, 2	SOL1, 2	Controls Path for Heating or Cooling
Liquid Pipe 2	LP2	Liquid Pipe to the Indoor Unit(s)
Vapor Pipe	GSP	Vapor Pipe to the Indoor Units
Balancing Valve	BLV	Controls the Pressure Between High and Low Pressure Pipes During Operation Changeover
Subcooling EEV	SCEEV	Controls Subcooling

Figure 23: Heat Recovery Unit Parts Diagram.

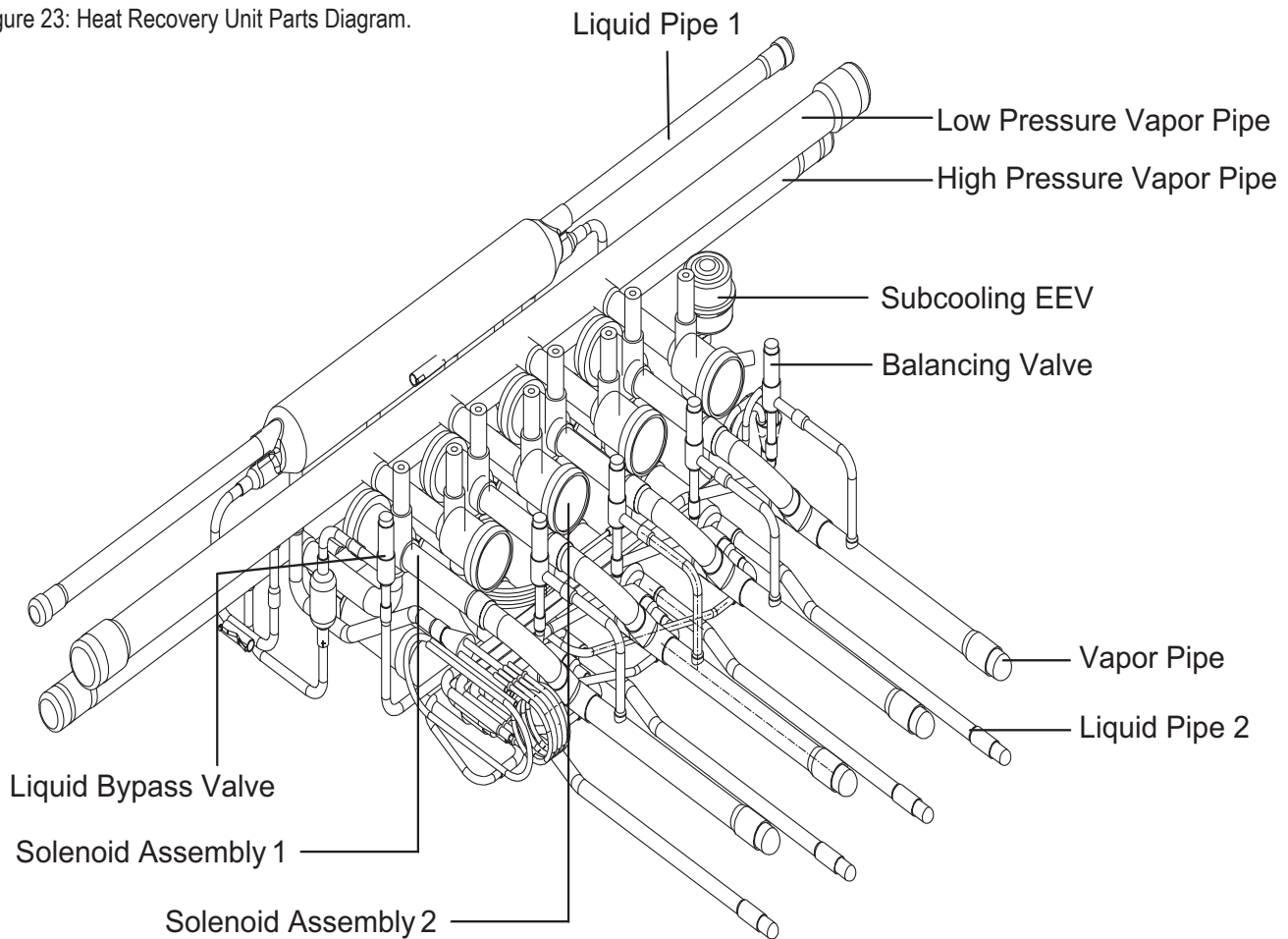

HEAT RECOVERY UNIT DIMENSIONAL DIAGRAMS

MULTI V^S

PRHR022A Heat Recovery Unit

W	17-7/8"
H	8-5/8"
D	18-15/16"
L1	6-7/8"
L2	6-5/8"
L3	11-3/8"
L4	6-7/8"
L5	3-1/2"
L6	5-1/2"
L7	1-3/16"
L8	3-9/16"
L9	5-7/16"
L10	4-3/4"
L11	5-3/4"
L12	7-1/4"
L13	1-1/4"
M1	3-3/4"
M2	13-5/8"
M3	1-1/2"
M4	18-15/16"

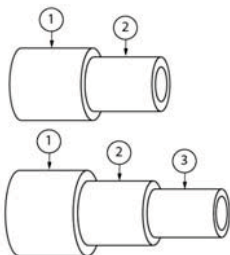
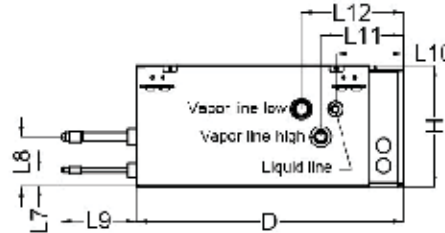
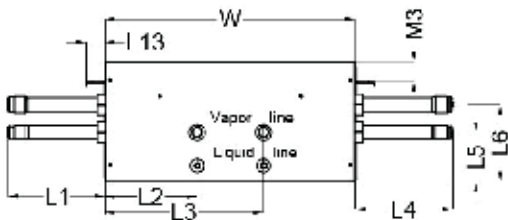
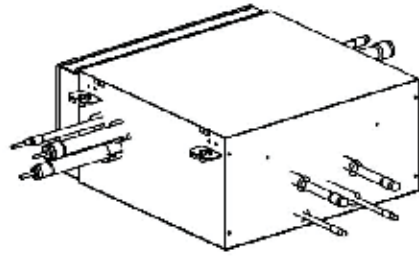
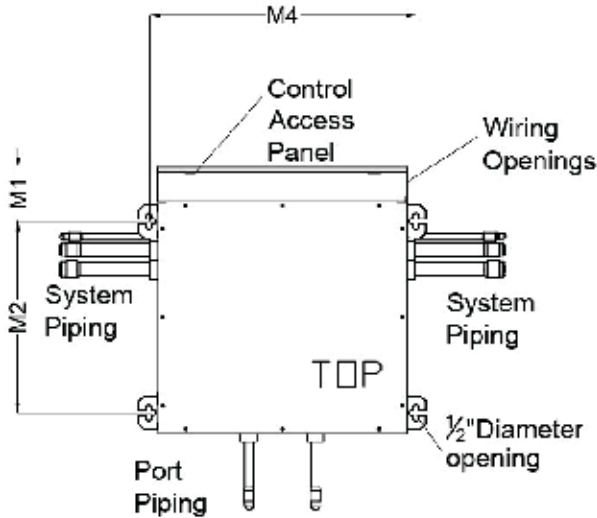

Reducer Dimensions (in)					
		1	2	3	Quantity
Indoor Unit	Liquid Line	3/8 OD	1/4 OD	-	2
	Vapor Line	5/8 OD	1/2 OD	-	2
HR Unit	Liquid Line	3/8 OD	1/4 OD	-	2
	Vapor Line Low	5/8 OD	1/2 OD	-	2
		7/8 OD	3/4 OD	5/8 OD	2
	Vapor Line High	1/2 OD	3/8 OD	-	2
3/4 OD		5/8 OD	1/2 OD	2	

HEAT RECOVERY UNIT DIMENSIONAL DIAGRAMS

PRHR032A Heat Recovery Unit

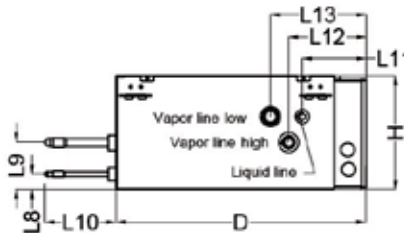
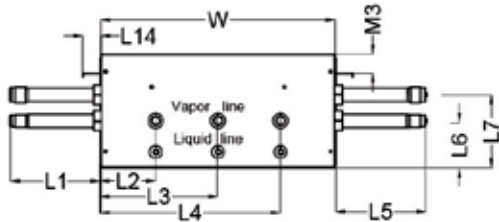
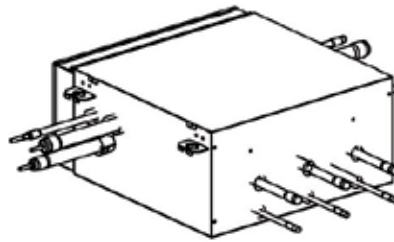
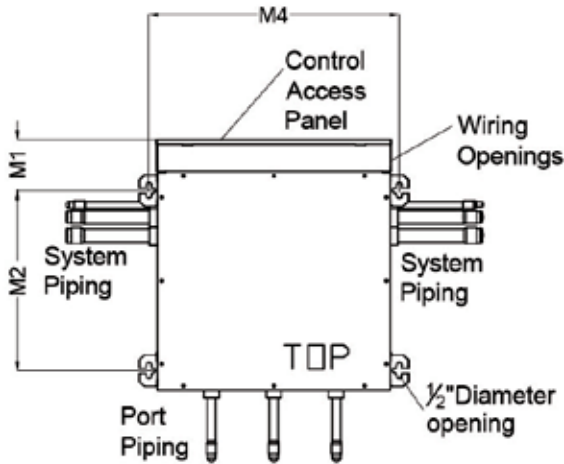

W	17-7/8"
H	8-5/8"
D	18-15/16"
L1	6-7/8"
L2	4-1/4"
L3	9"
L4	13-3/4"
L5	6-7/8"
L6	3-1/2"
L7	5-1/2"
L8	1-3/16"
L9	3-9/16"
L10	5-7/16"
L11	4-3/4"
L12	5-3/4"
L13	7-1/4"
L14	1-1/4"
M1	3-3/4"
M2	13-5/8"
M3	1-1/2"
M4	18-15/16"

Heat Recovery Unit Functions

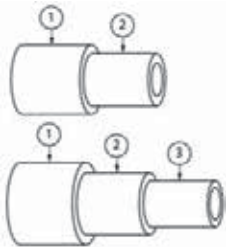

Reducer Dimensions (in)					
		1	2	3	Quantity
Indoor Unit	Liquid Line	3/8 OD	1/4 OD	-	3
	Vapor Line	5/8 OD	1/2 OD	-	3
HR Unit	Liquid Line	1/2 OD	3/8 OD	-	2
	Vapor Line Low	3/4 OD	5/8 OD	-	2
		1-1/8 OD	7/8 OD	3/4 OD	2
	Vapor Line High	5/8 OD	1/2 OD	-	2
7/8 OD		3/4 OD	5/8 OD	2	

HEAT RECOVERY UNIT DIMENSIONAL DIAGRAMS



PRHR042A Heat Recovery Unit

W	17-7/8"
H	8-5/8"
D	18-15/16"
L1	6-7/8"
L2	4-1/4"
L3	7-1/2"
L4	10-1/2"
L5	13-3/4"
L6	6-7/8"
L7	3-1/2"
L8	5-1/2"
L9	1-3/16"
L10	3-9/16"
L11	5-7/16"
L12	4-3/4"
L13	5-3/4"
L14	7-1/4"
L15	1-1/4"
M1	3-3/4"
M2	13-5/8"
M3	1-1/2"
M4	18-15/16"

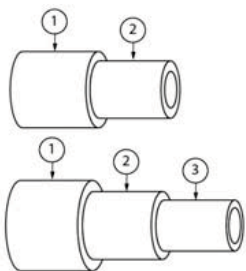
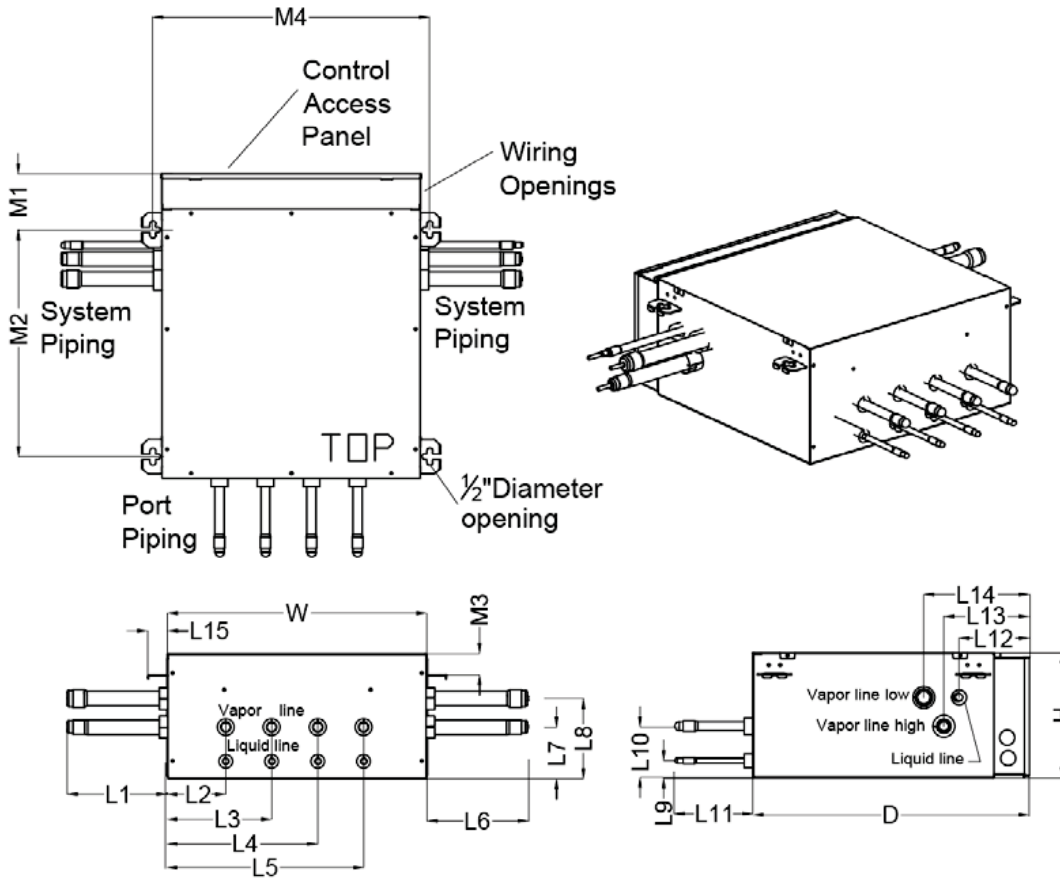

Reducer Dimensions (in)					
		1	2	3	Quantity
Indoor Unit	Liquid Line	3/8 OD	1/4 OD	-	4
	Vapor Line	5/8 OD	1/2 OD	-	4
HR Unit	Liquid Line	1/2 OD	3/8 OD	-	2
	Vapor Line Low	3/4 OD	5/8 OD	-	2
		1-1/8 OD	7/8 OD	3/4 OD	2
	Vapor Line High	5/8 OD	1/2 OD	-	2
7/8 OD		3/4 OD	5/8 OD	2	

PRHR022A, 032A, 042A

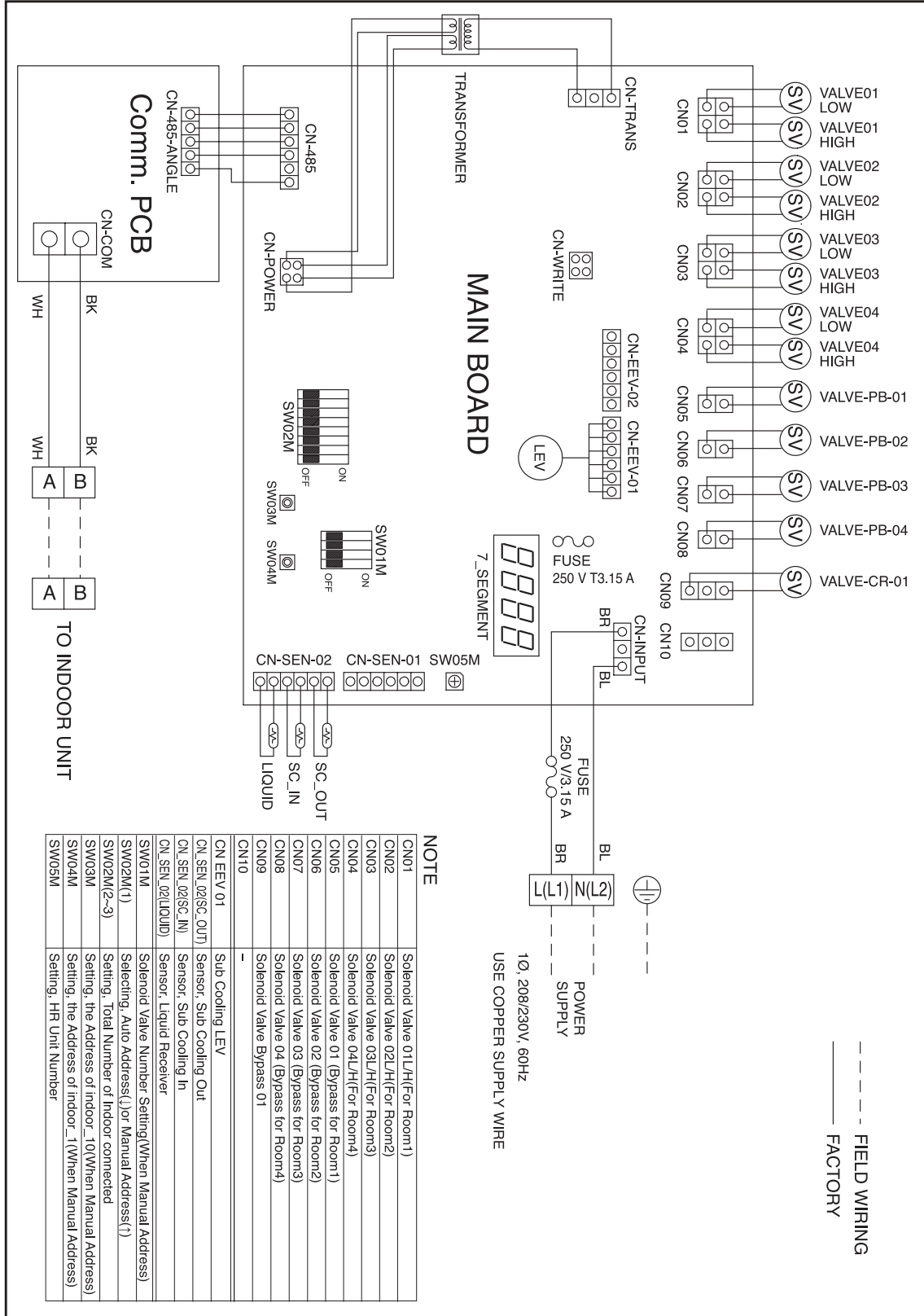

HEAT RECOVERY UNIT REFRIGERANT CIRCUIT DIAGRAM

MULTI V^S

PRHR022A, 032A, 042A

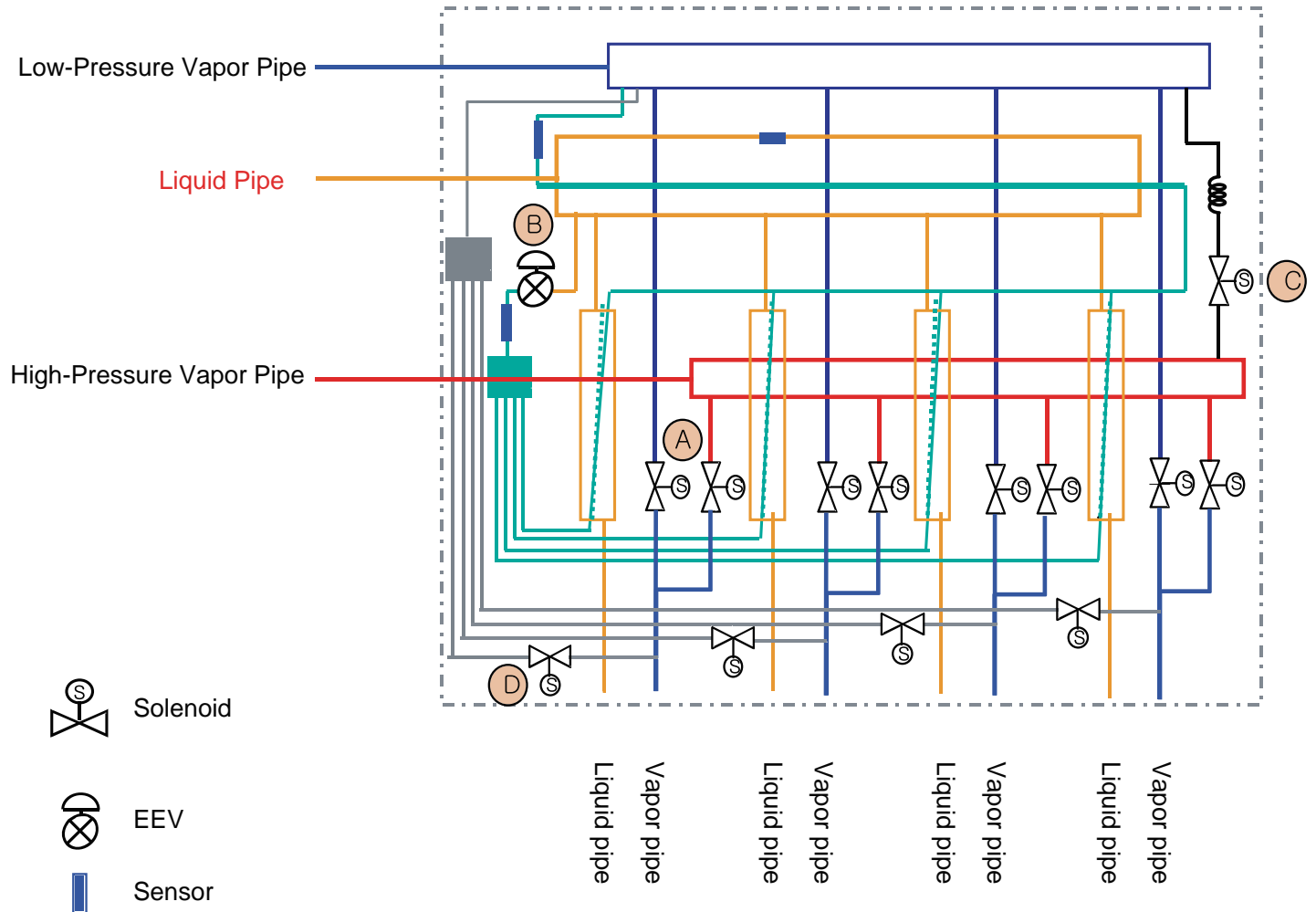

A : Switches operation between cooling and heating.

B : Decreases noise following subcooling operation between inlet of one indoor unit and outlet of another indoor unit during simultaneous operation.

C : Prevents liquid from entering high-pressure vapor valve and heat recovery unit during cooling mode.

D : Controls pressure between the high and low pressure vapor pipes during simultaneous operation.

Normal Operation

Table 39: Normal Operation Functions.

Component	Power On	Cooling Operation	Heating Operation	Stop Operation
High Pressure Vapor Valve	Close	Close	Open	Keep
Low Pressure (Vapor Valve	Open after thirty (30) seconds	Open	Close	Keep
Liquid Valve	Close	Open	Close	Close

Start Control (Heating Mode Only)

When the system operates in heating mode, all of the high pressure vapor valves in the heat recovery unit are open.

Valve Control

See Mode Change Time Calculations in the "Mode Change Time Calculation" table. How the valves are controlled by the Mode Change Time can be seen in the "Valve Control by Mode Change Time" table.

Table 40: Mode Change Time Calculation.

Previous Mode	Change Mode	Mode Change Time
Stop or Ventilation	Cooling or Heating	120 seconds
Cooling	Heating	180 seconds
Heating	Cooling	120 seconds
Cooling or Heating	Stop or Ventilation	During Heating: 60 seconds During Cooling: 0 seconds

Note:

The time of Mode Change Time will differ based on the software version of the heat recovery unit PCB.

Table 41: Valve Control by Mode Change Time.

Operation Mode	Mode Change Time	High Pressure Vapor Valve	Low Pressure Vapor Valve	Balancing Valve
Cooling	$120 \leq \text{Time}$	Keep	Keep	Close
	$0 < \text{Time} < 120$	Close	Close	Open
	$\text{Time} = 0$	Close	Open	Close
Heating	$180 \leq \text{Time}$	Keep	Keep	Close
	$0 < \text{Time} < 180$	Close	Close	Close
	$\text{Time} = 0$	Open	Close	Close
Stop or Ventilation	$0 < \text{Time} < 5$	Cooling Mode: Close	Keep	Close
	$\text{Time} = 0$	Heating Mode: Low Pressure Vapor Valve → Close	Keep	Close

HEAT RECOVERY UNIT FUNCTIONS



Special Control

Oil Return / Defrost Control

Table 42: Oil Return / Defrost Control.

Component	Start	During Operation	Stop
Inverter Compressor	Stop	60 Hz	40 Hz
High Pressure Vapor Valve	Keep	Close	Open or Close
Low Pressure Vapor Valve	Keep	Open	Open or Close
Balancing Valve	Open for 30 seconds	Close	Close

Liquid Bypass Control

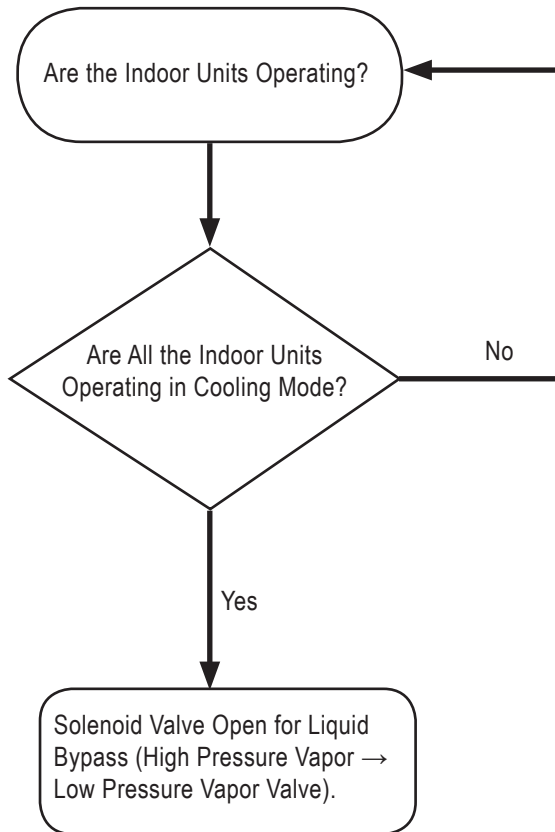

Subcooling EEV Control

Subcooling EEV operates with fuzzy logic to keep the degree of subcooling (Target: About 77°F) at the outlet of the subcooler during simultaneous cooling / heating operation.

$$\text{Temperature of Subcooler} = T_{\text{Subcooler Outlet}} - T_{\text{Subcooler Inlet}}$$

Addressing with Heat Recovery Units (For Heat Recovery Systems Only)

General

Each heat recovery unit will have a unique address assign so the outdoor unit will be able distinguish it from other heat recovery units. Upon completion of the heat recovery unit address, the heat recovery unit operating parameters will be set by adjusting the positions DIP switches on SW02M and SW01M.

Procedure

Before beginning the physical process of assigning heat recovery addresses, map out the address assignments using a copy of the LATS tree mode diagram.

Guidelines

1. Addresses must be sequential and cannot be skipped.
2. Assign the lowest address to the heat recovery unit that has the largest capacity indoor unit connected to port number 1. If the capacity of all indoor units connected to port number 1 of each heat recovery unit is the same, assign address "0" to the heat recovery unit farthest away from the outdoor unit. Assign the next address to the next farthest away and so on until all heat recovery units have an address. The heat recovery unit with the highest address must be the one closest to the outdoor unit. Up to 16 heat recovery units can be on a single system.

Possible settings in order of lowest to highest are: 0,1,2,3,4,5,6,7,8,9,A,B,C,D,E,F.

Note:

Addressing must be performed following the detailed steps above because port number 1 on the heat recovery unit addressed "0" will remain open during the auto pipe detect procedure. If the indoor unit capacity connected to the port is relatively small compared with other units on the system, the outdoor unit high head pressure safety will trip and shut down the unit during the procedure.

3. Record the address assigned to each heat recovery unit.

Figure 24: Heat Recovery Unit Main PCB.

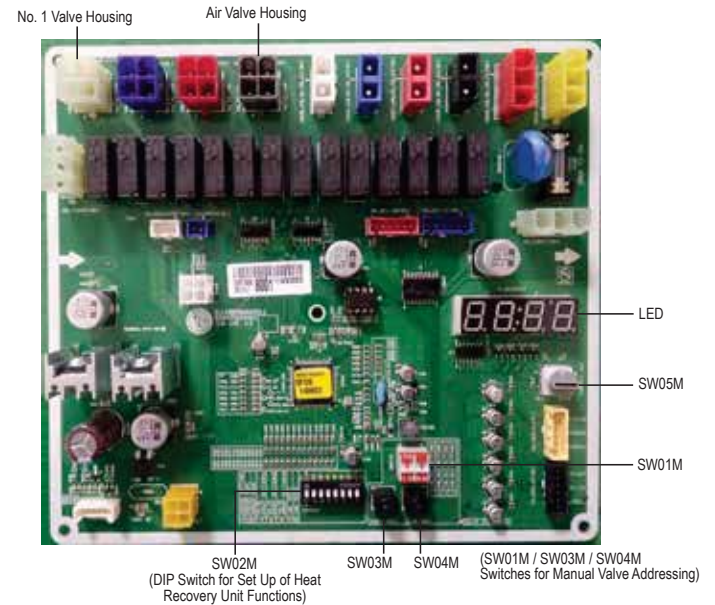
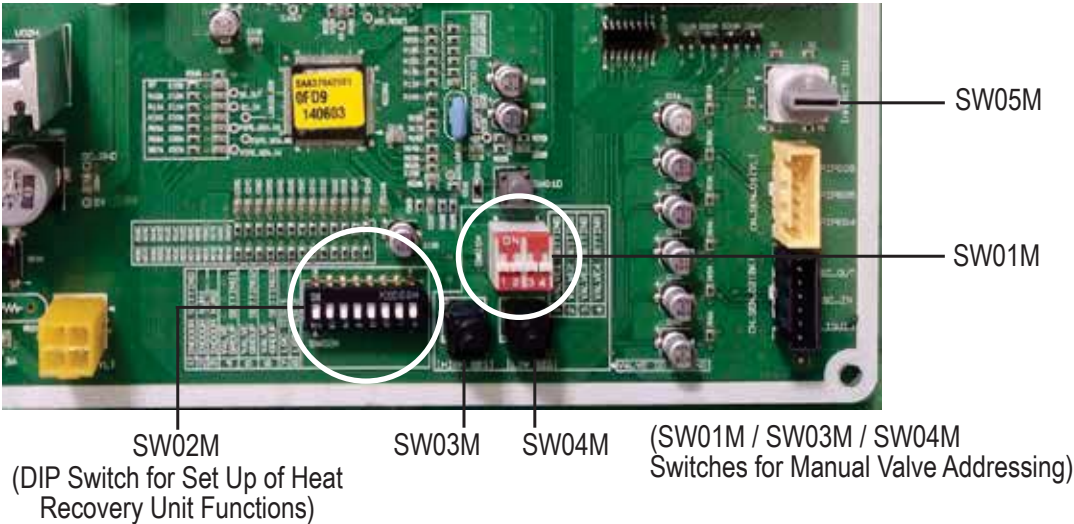

Figure 25: Close Up of DIP Switches and Rotary Dial on the Heat Recovery Unit Main PCB.



MULTI V S Outdoor Unit Service Manual

1. Main Function of SW02M.

ON S/W	Selection	
	No. 1	Method for addressing the heat recovery control valves (Auto / Manual)
No. 2	Model of heat recovery unit	
No. 3	Model of heat recovery unit	
No. 4	Valve group setting	
No. 5	Valve group setting	
No. 6	Valve group setting	
No. 7	Used only in factory production (preset to "OFF")	Zone setting ("ON")
No. 8	Used only in factory production (preset to "OFF")	

Selecting the Heat Recovery Unit Valve Addressing Method (Pipe Detection) (Auto / Manual).

Auto (Switch No. 1 on SW02M OFF)

Manual (Switch No. 1 on SW02M ON)

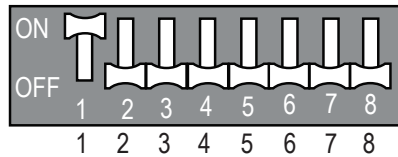
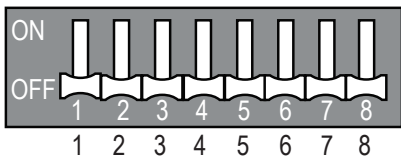

Zone Control Setting.

	DIP Switch Settings	
Normal Control	<p>SW02M</p>	<p>SW01M</p>
Zone Control	<p>SW02M</p>	<p>SW01M</p> <p>Turn the DIP Switch of the zoned branch to ON. Example: Branches one (1) and two (2) are set to zone control.</p>

Select the Heat Recovery Unit Model.

1. Identify how many ports are connected (see table below).
2. Group ports if necessary. If any connected indoor units are "large" capacity models (indoor units with >54,000 Btu/h capacity) two heat recovery ports must be "grouped" to serve a large capacity indoor using an inverted 'Y' branch.
3. Set switches on SW02M as outlined in the table below and on the next page.

Table 43: Selecting the Heat Recovery Unit Model.

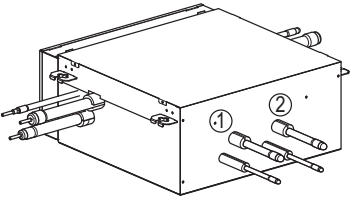
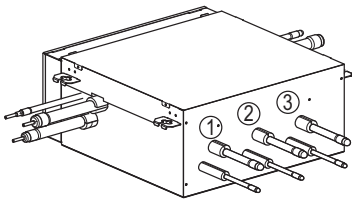
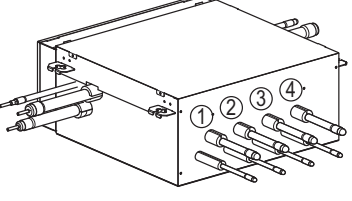
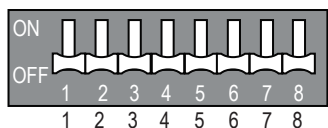
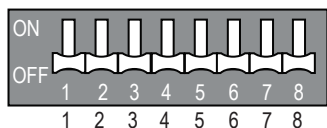
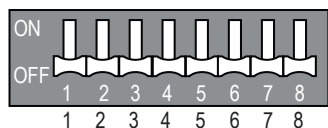
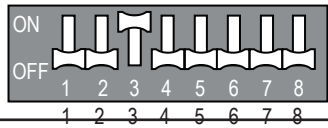
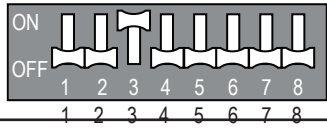
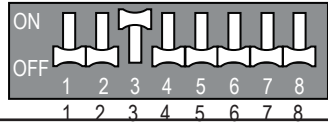
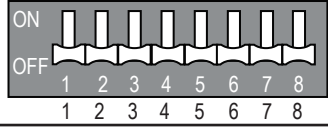
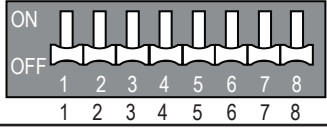
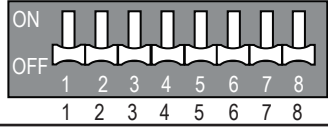
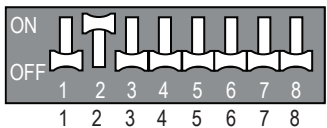
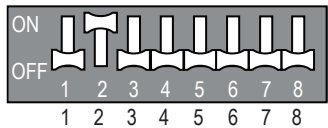
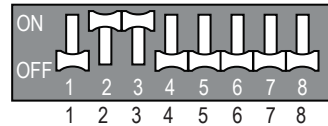
	 PRHR022A (Two [2] ports)	 PRHR032A (Three [3] ports)	 PRHR042A (Four [4] ports)
Factory Setting			
One port connected			
Two ports connected			
Three ports connected			
Four ports connected			

Note:

DIP Switch SW02M bank is factory set to all OFF for all heat recovery units.

- To use a PRHR022A for one port, cap off the second pipe, and set the DIP switches on the heat recovery unit for "one port connected" as shown in the table above.
- To use a PRHR032A for two ports, cap off the third port, and set the DIP switches on the heat recovery unit for "two ports connected" as shown in the table above.
- To use a PRHR042A for three ports, cap off the fourth port, and set the DIP switches on the heat recovery unit for "three ports connected" as shown in the table above.
- To use a PRHR042A for two ports, cap off the third and fourth ports, and set the DIP switches on the heat recovery unit for "two ports connected" as shown in the table above.
- Any unused port must be sealed with a brazed copper cap,  not with a plastic cap.

HEAT RECOVERY UNIT SETTINGS

Select the Valve Group.

Table 44: SW02M Valve Group Settings.

	DIP Switch Setting	Example
No Valve Group Control		<p>Indoor unit Indoor unit Indoor unit Indoor unit</p>
No. 1, 2 Valve Control		<p>Indoor unit Indoor unit Large capacity indoor unit</p>
No. 2, 3 Valve Control		<p>Indoor unit Large capacity indoor unit Indoor unit</p>
No. 3, 4 Valve Control		<p>Large capacity indoor unit Indoor unit Indoor unit</p>
No. 1, 2 Valve Control No. 3, 4 Valve Control		<p>Large capacity indoor unit Large capacity indoor unit</p>

Note:

If large capacity indoor units (larger than 54,000 Btu/h) are installed, the Y-branch pipe shown in the table below must be used to twin the ports.

Kit Model No.	Vapor Pipe Dimensions	Vapor Pipe Model No.	Liquid Pipe Dimensions	Liquid Pipe Model No.
ARBLN03321		AJR54072906		AJR54072902

2. SW05M Function (Rotary Switch for Addressing Heat Recovery Units).

Rotary switch SW05M must be set to "0" when installing only one heat recovery unit. Figure 26: Adjusting the Heat Recovery Unit Addresses.

- When installing multiple heat recovery units, address each unit with sequentially increasing numbers starting from "0".

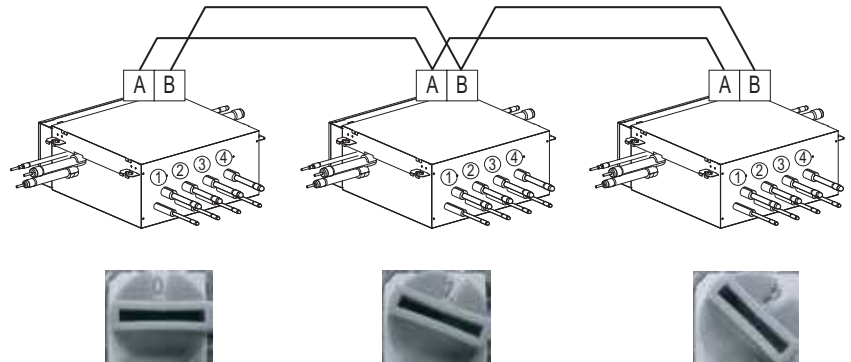

3. SW01M / SW03M / SW04M (DIP and Tact Switches) for Manual Valve Addressing

Non-zoning (Normal Setting).

- Set the address of the heat recovery unit valve to the central control address of the connected indoor unit.
- SW01M: Select the valve to address.
- SW03M: Increases the valve address by ten (10).
- SW04M: Increases the valve address by one (1).

Note:

- Indoor units must be addressed first with a central control address.
- Each indoor unit must have a unique, preset central control address (using its wired controller) before manual valve addressing can occur.

Table 45: Settings for Manual Valve Addressing, Non-Zoning.

PCB Component	S/W No.	Set Up
	No. 1	Manual Addressing Valve No. 1
	No. 2	Manual Addressing Valve No. 2
	No. 3	Manual Addressing Valve No. 3
	No. 4	Manual Addressing Valve No. 4
	SW03M	Increases the Valve Address by Ten (10)
	SW04M	Increases the Valve Address by One (1)

3. SW01M / SW03M / SW04M (DIP and Tact Switches) for Manual Valve Addressing, continued.

Zoning

- Set the address of the heat recovery unit valve to the central control address of the connected indoor unit.
- SW01M: Select the valve to address.
- SW03M: Increases the valve address by ten (10).
- SW04M: Increases the valve address by one (1).
- SW05M: Rotary switch

Note:

Each indoor unit must have a unique, preset central control address (using its wired controller) before manual valve addressing can occur.

Table 46: Settings for Manual Valve Addressing, Zoning.

PCB Component	S/W No.	Set Up
	No. 1	Manual Addressing Valve No. 1
	No. 2	Manual Addressing Valve No. 2
	No. 3	Manual Addressing Valve No. 3
	No. 4	Manual Addressing Valve No. 4
	SW03M	Increases the Valve Address by Ten (10)
	SW04M	Increases the Valve Address by One (1)
	SW05M	Manual Addressing of Zoned Indoor Units

Indoor Unit Auto Addressing Procedure

⚠ WARNING

Disconnects must only be operated by a properly licensed electrician at this time. Ⓣ Never look at a disconnect switch when closing. Turn away from the switch when closing. Incorrect wiring could cause the disconnect to explode, physical injury, and / or death.

Note:

- Supply power to the indoor units. If power is not supplied, an operation error will occur.
- Error No. CH200 will appear when the auto addressing procedure has failed. See the Troubleshooting section for information on how to resolve Error No. CH200.
- During the pre-commissioning process for systems with Gen 4 indoor units, Ⓣ do not change any DIP switch settings except for No. 3 on SW01B, which must be ON to enable Gen. 4 features. All other combinations of switches (one [1] through seven [7]) must be left in the OFF position on the outdoor unit DIP switch bank SW01B.
- If the Auto Address Procedure has never been successfully completed for the system, the compressor(s) will not start when power is applied to the unit.
- Auto addressing is only possible on the PCB of the outdoor unit.
- If an indoor unit PCB has been replaced, the auto addressing procedure must be performed again.

1. Verify all that all indoor units connected to the system have power to the PCB board AND all zone controller system start buttons are OFF.
2. Remove the maintenance access panel and unit control box cover from the outdoor unit. Place panels and screws in a secure area.
3. Verify that the communications cable between the indoor units and the outdoor unit is terminated at the outdoor unit terminals IDU(A) and IDU (B).
4. Verify the shield on the communications cable is grounded at the outdoor unit. The shields must be tied together and taped back.
5. Check if all DIP switches are set to OFF.
6. Cycle power on the outdoor units, indoor units, etc., and wait three (3) minutes while the outdoor unit sequences through the self-diagnostics check, and to improve indoor unit communication when initial power is supplied. Leave disconnect in the "ON" position.
7. Check the outdoor unit(s) current configuration code(s). Observe the unit setup codes using the SSD display found on the outdoor unit PCB. Each code will display for two (2) seconds.

Note:

After the self-diagnostics check is complete, the SSD must be clear and nothing displayed. Diagnostic process must take from three (3) to seven (7) minutes.

8. Know how many indoor units are connected to the system.
9. Press and hold the red SW01C button for about five (5) seconds. Release when "88" appears on the SSD. After three (3) to seven (7) minutes, the display will flash a number for about ten (10) to thirty (30) seconds indicating how many indoor units the system successfully communicated with.
10. This number must match the known installed number of indoor units if the auto addressing procedure was successful. If using LGMV, read the address of each indoor unit. The address of each indoor unit is also indicated on wired remote control displays.
11. Upon completion of the auto addressing routine, the display will be blank and the system will be in standby waiting for another command.
12. Upon successful completion of the auto address procedure, record the system address assigned to each indoor unit by the auto address procedure.

Figure 27: Auto Address Button Location on ARUN24~53GSS4 Outdoor Unit PCB.

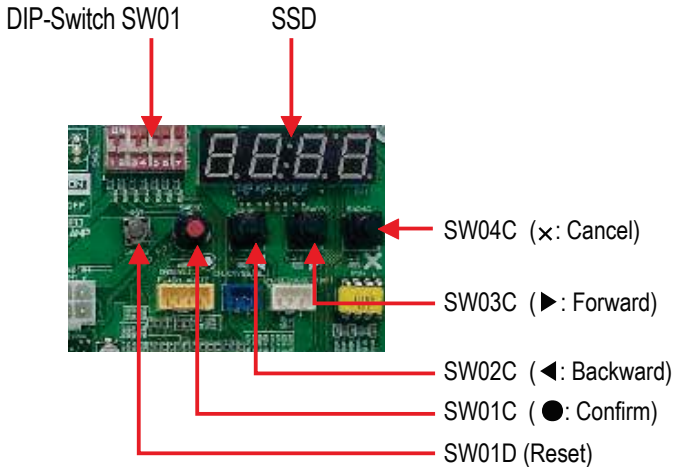

Figure 28: Auto Address Button Location on ARUN60GSS4 and ARUB60GSS4 Outdoor Unit PCB.

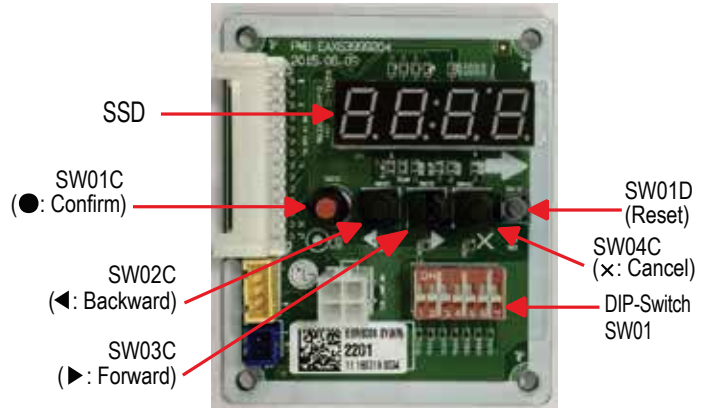
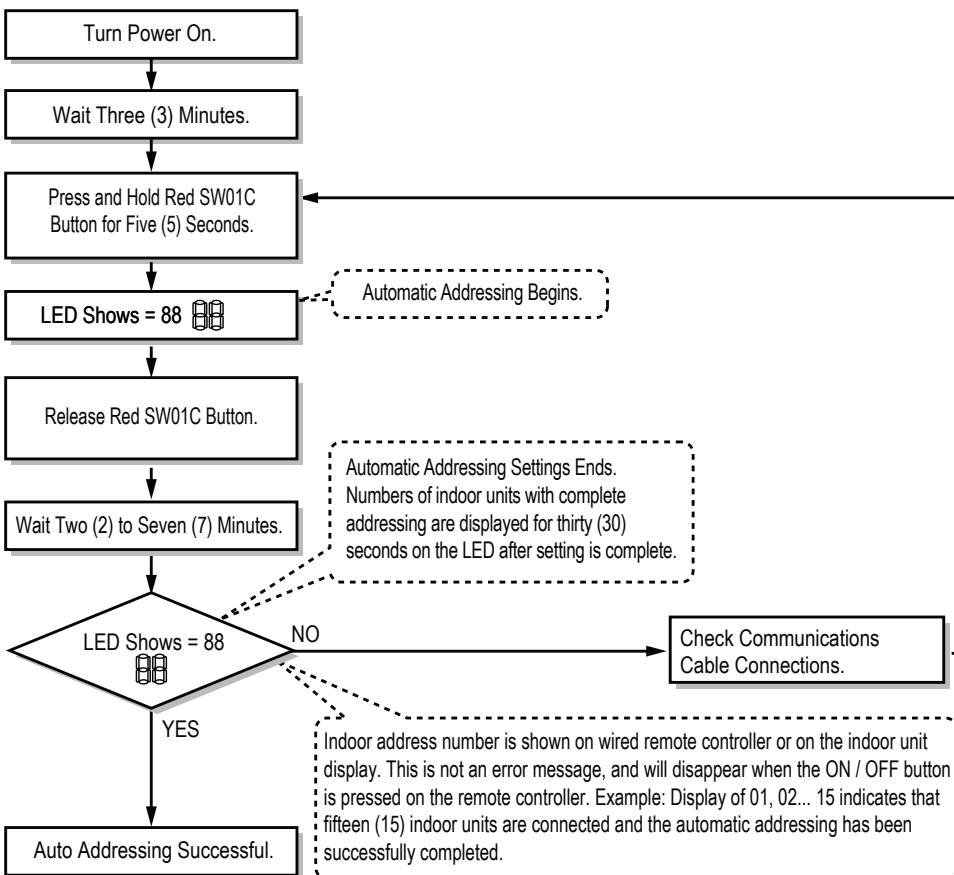



Figure 29: Indoor Unit Auto Addressing Procedure Flowchart.



Troubleshooting a Failed Indoor Unit Auto Addressing Procedure

Note:

If the quantity of indoor units the auto addressing procedure found is incorrect, or the "88" never disappears from the display for the seven (7) minutes, the auto address routine has failed and a communications problem exists. If the Auto Address Procedure failed:

1. Verify ALL indoor unit ON / OFF buttons are in the OFF position (i.e., ON / OFF button NOT illuminated).
2. Check the terminations, polarity, and continuity of each conductor on the communications cable between the outdoor unit and the indoor units. Verify the indoor unit to outdoor unit communications cable is wired correctly.
3. Verify the shield of the communications cable is grounded at the outdoor unit only. All segment shields must be spliced together at each indoor unit and  NOT grounded.
4. After repairing the communications cable, go to Step 9 of the Initiate the Auto Addressing Procedure and repeat the process until successful: Press and hold the red SW01C button for about five (5) seconds. Release when "88" appears on the SSD. After three (3) to seven (7) minutes, the display will flash a number for about thirty (30) seconds indicating how many indoor units the system successfully communicated with.
5. This number must match the known installed number of indoor units if the auto addressing procedure was successful.
6. Upon completion of the auto addressing routine, the display will be blank and the system will be in standby waiting for another command.
7. Record the system address the outdoor unit assigned to each indoor unit by the auto address procedure.

Auto Addressing for Pipe Detection

Auto addressing for pipe detection function sets the connection relationship automatically between the indoor units and the heat recovery units.

1. Turn No.1 of SW02M on the heat recovery unit PCB to OFF.
2. Confirm that the setting of Nos. 2, 3 of SW02M corresponds with the number ports used.
3. Reset the power of heat recovery unit PCB.
Turn master outdoor unit PCB No. 5 DIP switch to ON.
4. Select the "Idu" mode using ► and ◀, then push the ● button.
5. Select the "Id 5" "Ath" or "Atc" function using ► and ◀, then push the ● button. If outdoor temperature is >59°F, use "Ath". If that does not work, use "Atc." If outdoor temperature is <59°F, use "Atc". If that does not work, use "Ath."

Note:

Atc = "At-cold outside", and Ath = "At-hot outside". Select accordingly.

6. Select the "Idu" mode using ► and ◀, then push the ● button.
7. Select the "Id 6 StA" function using ► and ◀, then push the ● button.
8. The number "88" is displayed on the SSD of the outdoor unit main PCB. If the display shows -----, then wait longer.
9. The automatic pipe detection procedure starts.
10. The procedure will run from five (5) to sixty (60) minutes, depending on the number of connected indoor units, and the ambient outdoor temperature.
11. The number of indoor units detected is displayed for thirty (30) seconds to one (1) minute on the outdoor unit PCB after the outdoor unit stops.
 - The number of indoor units connected to each heat recovery unit will be displayed.
 - If there is an auto pipe detection error, "200" will be displayed.

Note:

- Run the auto addressing and auto pipe detection procedures again whenever an indoor unit PCB and / or and heat recovery unit PCB are replaced. Apply power to the indoor units and heat recovery units after the repair is complete, otherwise operation errors will occur.
- Error No. 200 occurs if the number of actual connected indoor units and the number of detected indoor units are different.
- If the auto pipe detection procedure fails, perform the manual pipe detection procedure. (If the auto pipe detection procedure is successful, the manual pipe detection procedure is not required.)
- The auto pipe detection procedure can be run again after a failed auto pipe detection procedure attempt; just reset the outdoor unit first.
- Ⓞ Do not turn off the main unit PCB for at least five (5) minutes after the auto pipe detection procedure is complete; allow time for the outdoor unit to automatically save auto pipe detection results.

Figure 30: Auto Addressing for Pipe Detection Procedure Flowchart.

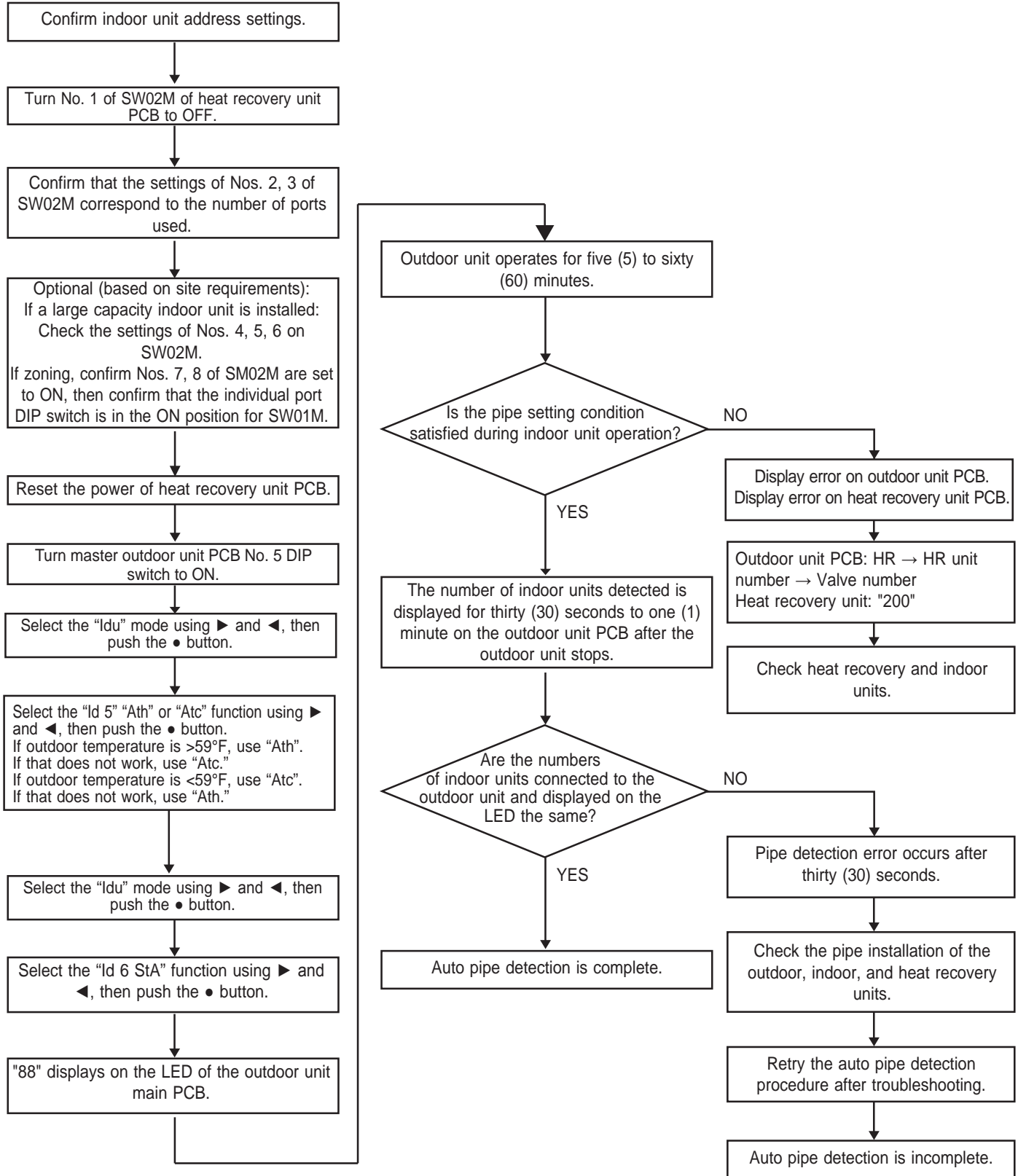

Manual Pipe Detection Addressing

1. Enter the central control address into each indoor unit using its wired remote control. If a controller is not available, a controller needs to be added.
2. Turn No. 1 of DIP switch bank SW02M of the heat recovery unit PCB ON.
3. Reset the power of the heat recovery unit PCB.
4. Through the heat recovery unit PCB, manually set address of each heat recovery unit valve to the central control address of the indoor unit connected to that valve.
5. Reset the power to the outdoor unit PCB.
6. The number of the indoor unit installed will be displayed after about five (5) minutes. (Example: Heat Recovery Unit to the Number of the Indoor Unit.)
7. Reset the power of the outdoor unit PCB and the heat recovery unit.
8. Manual pipe detection addressing is complete.

Figure 32: Location of DIP Switch SW02M on the Heat Recovery Unit Main PCB.

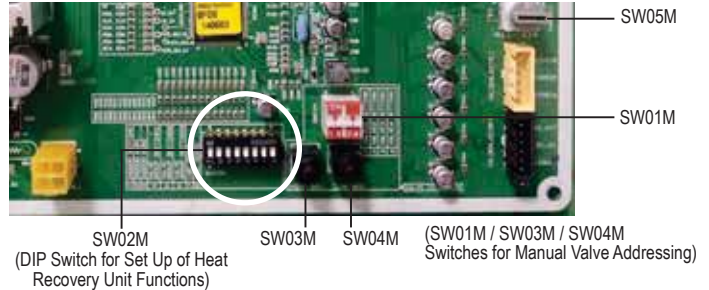
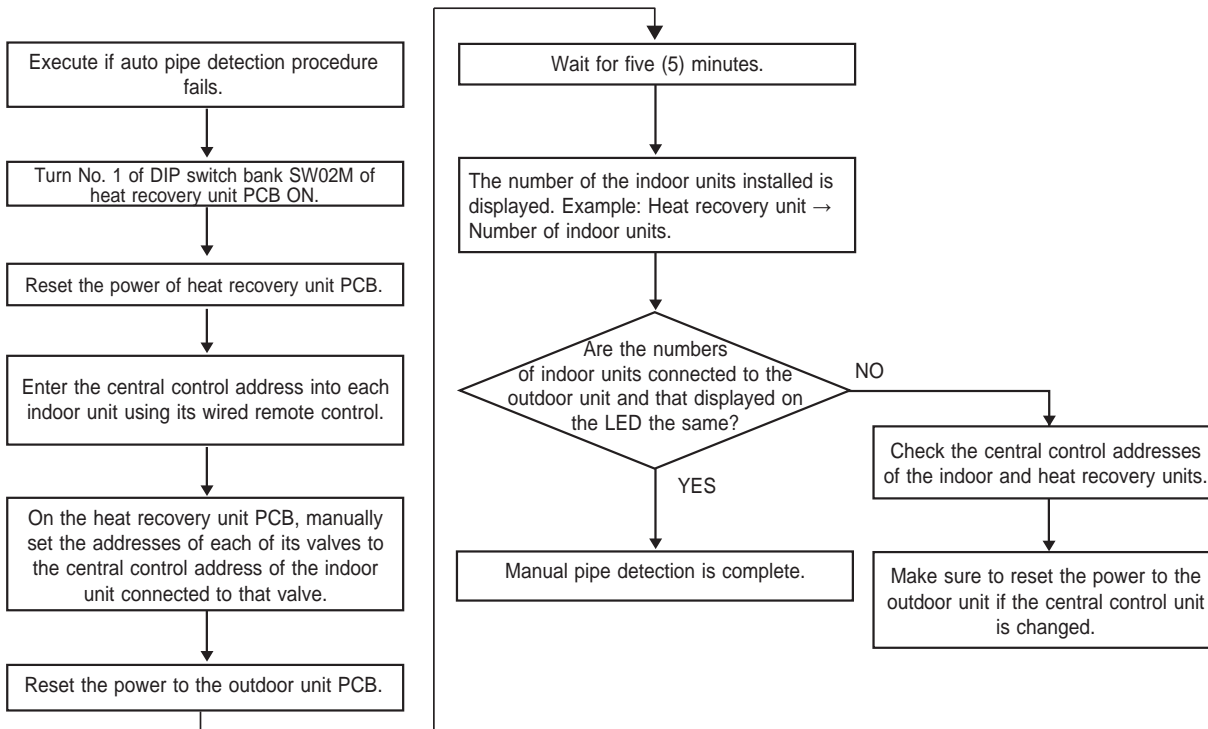

Figure 31: Manual Pipe Detection Addressing Flowchart.





Note:

1. If a central controller is not installed yet, leave the address data alone until the installer adds the central controller, and sets the central control address as desired.
2. If a central controller is already installed, the wired remote controller of the indoor units will provide the central control addresses. (In this case, manually set the heat recovery unit pipe address following the central control address of the indoor unit.)
3. Central controller addresses must be set manually at each individual controller.
4. A pipe that does not have an indoor unit connected to it must be set with a different address than a pipe that does have an indoor unit connected to it. (If addresses are the same, the valves will not operate.)
5. Change the manual pipe settings using the heat recovery unit PCB.
6. An error indicates that the manual pipe detection procedure was not completed properly.
7. To save the pipe detection procedure results automatically, Ⓞ do not turn off the main outdoor unit PCB for five (5) minutes after the procedure has finished.

Manual Pipe Detection Example (Non-Zone Setting)

Before performing manual pipe addressing, input a different central control address to every indoor unit through either a wired or a wireless controller (depending on indoor unit type).

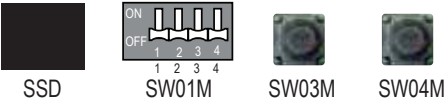
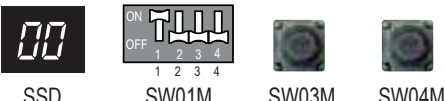
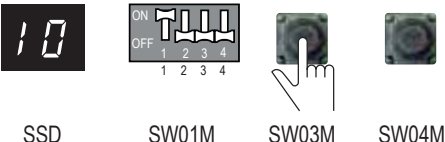
Example: An indoor unit with a central control address of "11" is connected to valve "1" of a heat recovery unit.

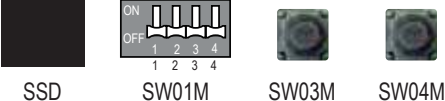
No.	Display / Setup	Description
1		Operation: None Display: None
2		Operation: Turn DIP switch No. 1 on to address valve No. 1 (SW01M). Display: Existing value saved in EEPROM is displayed on LED.
3		<ul style="list-style-type: none"> • Operation: Set the "10" digit of the Group High data number of the wired remote control connected to the corresponding indoor unit to the valve No. 1 by pressing left tack switch (SW03M). • Display: Digit increases with the number of times the tack switch is pressed, shown on left LED numeral.
4		<ul style="list-style-type: none"> • Operation: Set the "1" digit of the Group Low data number of the wired remote control connected to the corresponding indoor unit to the valve No. 1 by pressing right tack switch (SW04M). • Display: Digit increases with the number of times the tack switch is pressed; shown on right LED numeral.
5		<ul style="list-style-type: none"> • Operation: Turn DIP switch No. 1 off to save the address of valve No. 1 (SW01M0) • Display: "11" displayed on LED disappears

Note:

- The procedure described above must be performed for all heat recovery unit valves.
- Valves that do not have indoor units connected to them must be addressed with a number that has not been used. (Valves will not work if the address numbers are the same.)

Manual Pipe Detection Example (Zone Setting)

Zone control is when two (2) or more indoor units are connected to one (1) valve of the heat recovery unit. For this application, set the controls with the multiple indoor connections using the rotary switch; i.e., only the rotary switch changes the same valve set condition and set indoor units connection.

1. Set the DIP switch on the corresponding valves and the rotary switch to "0".
2. Set the number using the tact switches.
3. If additional indoor units are connected to one heat recovery unit valve, increase the rotary switch setting by one (1) and set the number using the tact switches.
4. To verify the number of the corresponding valve, turn the DIP switch to ON and set the number on the rotary switch.
5. One heat recovery unit valve can support up to eight (8) indoor units per port (rotary switch settings 0~7). An error will display if more than eight (8) indoor units per heat recovery valve are set with the rotary switch.
6. Return the rotary switch to its original setting (heat recovery unit number settings) after all pipe settings are complete.
7. The rotary switch setting valve of the number of indoor units connected to "FF" prevents a malfunction. Example: Where three (3) indoor units are connected to valve 1; rotary switch settings are 0,1,2 and 3,4,5,6,7 with "FF" used. (Prerequisite for manual pipe detection: The central control address of each indoor unit must be preset differently using its wired remote control.)

Example: An indoor unit with a central control address of "11" is connected to valve no. "1" of an heat recovery unit.

No.	Display / Setup	Description
1	LED SW01M SW03M SW04M SW05M	Operation: None Display: None
2	SSD SW01M SW03M SW04M SW05M	Operation: Turn DIP switch No. 1 on to address valve No. 1. Display: Existing value saved in EEPROM is displayed on LED.
3	SSD SW01M SW03M SW04M SW05M	<ul style="list-style-type: none"> • Operation: Set the "10" digit to the number in Group High data of the wired remote control connected to the corresponding indoor unit with the valve No. 1 by pressing left tact switch. • Display: Digit increases with the number of times the tact switch is pressed, shown on left LED.
4	SSD SW01M SW03M SW04M SW05M	<ul style="list-style-type: none"> • Operation: Set SW05M to "1". • Display: Former set value is shown on LED.
5	SSD SW01M SW03M SW04M SW05M	<ul style="list-style-type: none"> • Operation: Set SW03M, SW04M, and SW05M to "1". • Display: Set value is shown on LED.
6	SSD SW01M SW03M SW04M SW05M	<ul style="list-style-type: none"> • Operation: Turn DIP switch No.1 to off to save the address of valve No. 1. • Display : Set value from previous step disappears; LED is blank.
7	SSD SW01M SW03M SW04M SW05M	<ul style="list-style-type: none"> • Operation: Addressing the return valve of the heat recovery unit. • Display: LED is blank.

Note:

- The procedure described above must be performed for all heat recovery unit valves.
- Valves that do not have connected indoor units must be addressed with a number that has not been used. (Valves will not work if the address numbers are the same.)

Example of Checking the Valve Address

Example: An indoor unit with a central control address of "11" is connected to heat recovery unit valve No. 1.

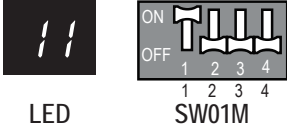
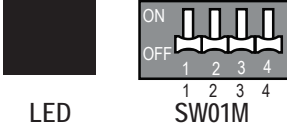
No.	Display / Setup	Description
1	 <p>LED</p> <p>SW01M</p>	<ul style="list-style-type: none"> • Operation: Turn DIP switch No. 1 to ON. • Display: "11" displays on SSD.
2	 <p>LED</p> <p>SW01M</p>	<ul style="list-style-type: none"> • Operation: Turn DIP switch No. 1 to OFF. • Display: SSD is blank.

Identifying the Manual Valve Address

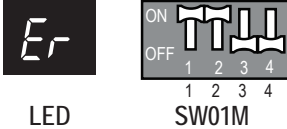
No.	Display / Setup	Description
1	 <p>LED</p> <p>SW01M</p>	<ul style="list-style-type: none"> • Operation: More than two (2) DIP switches turned ON. • Display: SSD displays "Er."

Note:

- Wait for eighty (80) seconds after power is turned ON.
- Zoning and master indoor unit information are removed from EEPROM after auto addressing.
- If a central control is installed, it is impossible to set the master indoor unit in zoning.

Be aware of the following safety precautions when troubleshooting the main components.

⚠ DANGER

- High voltage electricity is required to operate this system. Adhere to the NEC code and these instructions when wiring. Improper connections and inadequate grounding can cause accidental injury or death.
- Turn the power off before servicing the equipment. Electrical shock can cause physical injury or death.
- ⚡ Do not operate the disconnect switch with wet hands. There is risk of fire, electric shock, physical injury or death.

⚠ WARNING

- Disconnects must only be performed by a properly licensed electrician. Incorrect wiring could cause the disconnect to explode, leading to physical injury or death.
- ⚡ Do not supply power to the unit until all electrical wiring and controls wiring are completed. There is risk of fire, electric shock, physical injury or death.
- ⚡ Do not operate the unit with the panel(s) or protective cover(s) removed; keep fingers and clothing away from moving parts. The rotating, hot, cold, and high-voltage parts of the unit can cause physical injury or death.
- ⚡ Do not touch the refrigerant piping during or after operation. It can cause burns or frostbite.

Note:

- ⚡ Do not supply power to the unit until all electrical wiring and controls wiring are completely installed. The system will malfunction.
- If the power wiring and communication cables are not properly connected (connections switched), the communication components will burn out and the system will not operate.

Test Run Checklist

Table 47: Test Run Checklist.

1	Check for any refrigerant leaks in the piping system. Verify that all power wiring and communication cables are properly connected. Check for disconnected and loose power wiring and communication cables connections.
2	Measure the insulation resistance between the power supply terminal block and ground using a mega-tester device (DC 500V). Resistance must be $\geq 2.0 \text{ M}\Omega$; if the resistance is $< 2.0 \text{ M}\Omega$, ⚡ do not operate the unit. Note: • ⚡ Never perform the megaohm check on the terminal control board. This will damage the control board. • Immediately after installation, or if the system is off for a long period, refrigerant can accumulate in the compressor, which can cause the insulation resistance between the power supply terminal board and the ground to drop $< 2.0 \text{ M}\Omega$. If the insulation resistance is $< 2.0 \text{ M}\Omega$, the power is turned on, and the compressor crankcase heater operates for \geq six (6) hours, the refrigerant evaporates, which will cause the insulation resistance to increase.
3	For Heat Recovery Systems: Check if the liquid, high pressure vapor, and low pressure vapor piping valves are fully opened. For Heat Pump Systems: Check if the liquid and vapor piping valves are fully opened. Note: Tighten all caps on the liquid and gas (vapor) service valves.
4	• Check for any problems in the automatic addressing. • Check / confirm that there are no error messages displayed on the indoor units, wired controllers, or the outdoor unit SSD.

Note:

- Main power to the outdoor unit must always remain on during the cooling and heating seasons.
- Apply power after installation, and before performing the test run.
- Always apply power for six (6) hours to heat the crankcase heater before operating the system. The compressor will burn out if the crankcase heater is not preheated for at least six (6) hours. The compressor will also be damaged if the crankcase heater has not preheated for at least six (6) hours, and the system operates when the outdoor temperature is below 50°F).

Main Component Errors

Table 48: Main Component Errors.

Main component	Problem	Cause	Solution
Compressor	Not operating	Motor insulation damaged.	Check resistance between terminals and unit frames.
		Strainer is clogged.	Clean / change the strainer.
		Oil is leaking.	Check oil levels.
	Stopped during operation..	Motor insulation failed.	After disconnecting the compressor wiring, check resistance between terminals and unit frames.
	Abnormal noise during operation.	Bad or improper connections.	Check compressor connections.
Outdoor Unit Fan	High pressure error when unit operates in cooling mode.	Motor failure, bad ventilation around outdoor unit heat exchanger.	Check the outdoor unit fan operation after the outdoor unit(s) has(have) been turned off for a while. If any obstacles are around the outdoor unit heat exchanger, switch the outdoor unit OFF and remove.
Outdoor Unit EEV	Heating failure, frequent defrost.	Bad connector contact.	Check connector.
	No operation sound after switching on the power.	Coil failure.	Check resistance between terminals.
	Heating operation failed; outdoor unit heat exchanger is frozen.	EEV clogged.	Service necessary.
	Low pressure error or discharge temperature error.		

Note:

- When a system error occurs, the error code is displayed on the indoor unit or the wired control.
- If CH05/53 error occurs, check if auto-addressing is complete and the communication cables are properly installed.

Run Self Diagnostics Check

Using the DIP Switches

- Outdoor unit settings can be checked from the SSD.
- DIP switch settings must only be changed when the power to the outdoor unit is OFF.

⚠ WARNING

Power to the outdoor unit must be turned off before checking the DIP switch settings. If not, there is risk of electric shock and physical injury or death.

Using the Initial Display

1. Power all indoor units.
2. Verify the outdoor units to indoor units communications cable is installed and terminated correctly. Inspect terminals on the outdoor unit.
3. Verify that DIP switches were properly adjusted for the jobsite configuration.
4. Power the outdoor unit.
5. After power is provided to the main printed circuit board (PCB) on the outdoor unit for five (5) seconds, observe the SSD.
 - Wait. The perimeter segments will flash in sequence for forty-five (45) seconds.
 - Verify the microprocessor's outdoor unit configuration agrees with the submittal information approved the design engineer (see below).
 - Confirm that this step has been completed by checking the box provided on the Record following the information as it is provided. The date is provided in sequence, and segment of the sequence will remain lit for two (2) seconds.

Table 49: Display Code Definitions—Outdoor Unit Nominal Capacity.

Display Code	4	6	8	10	12	14
Nominal Mb/h	2	4	6	8	10	12

Table 51: Segment Display Sequence (Two [2] seconds per segment following a forty-five [45] second wait).

Sequence	Description	Code(s)
1	Nominal Capacity	4 - 14*
2	Unit Type	Heat Pump
		Heat Recovery
3	Unit Voltage	208-230V / 60Hz / 1Ø
4	Efficiency Level	Standard

*See tables above for code definitions.

Table 52: Example of Reading the Initial Display: ARUB060GSS4.

Sequence	Description	Display Code
1	60,000 Btu/h Nominal Capacity	07
2	Unit Type	Heat Recovery
3	Unit Voltage	208-230V / 60Hz / 1Ø
4	Efficiency Level	Standard

Figure 34: ARUN024~053GSS4 Heat Pump Outdoor Unit Main PCB for Settings.

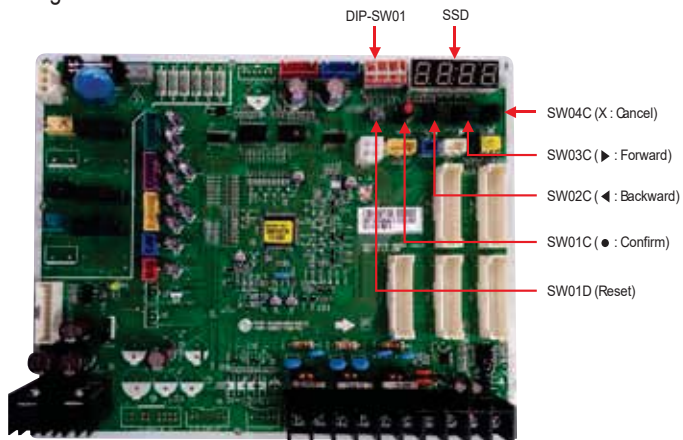

Figure 33: ARUN60GSS4 Heat Pump Outdoor Unit and ARUB060GSS4 Heat Recovery Outdoor Unit Service PCB for Settings.

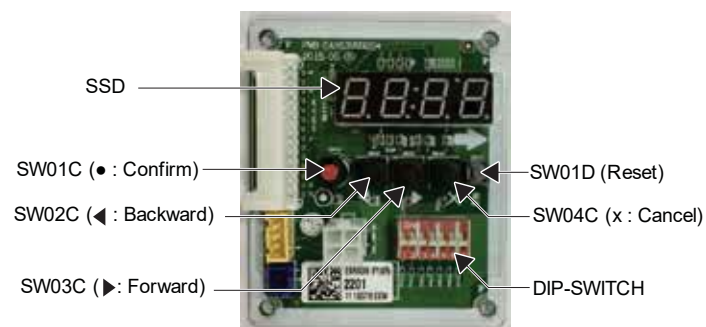
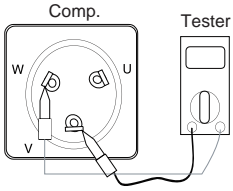
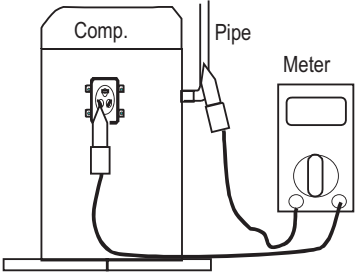

Table 50: Display Code Definitions—Voltage.

Outdoor Unit Code	22
Electrical Requirements	208-230V / 60Hz / 1Ø

Checking the Compressor

If a compressor error, or any error related to the electrical system has occurred, check for the items below and follow the procedure listed.

Step Number	Check for	Problem	Solution																																																												
1	How long has power been on during operation?	1. Power has been on for ≥ 12 hours. 2. Power has been on for ≤ 12 hours.	Go to Step 2. Go to Step 2 after power has been on for 12 hours.																																																												
2	<p>Does error occur again after starting operation?</p> <p>Test 1 Ohm meter testing terminal to terminal on the compressor.</p>  <p>Test 2 Ohm meter testing terminal to pipe ground. This reading must be $\geq 50M\Omega$.</p> 	<p>1. The compressor stops and same error appears again.</p> <p>2. Inverter output voltage is stable (1).</p> <p>3. Inverter output voltage is unstable or 0V (if digital tester is unavailable).</p>	<p>Check if IPM has failed.</p> <ul style="list-style-type: none"> Check insulation and coil resistors. If both are normal, restart the unit. If the same error occurs again, replace the compressor. Insulation resistor: $\geq 50M\Omega$ measured. Coil resistors for Heat Pump and Heat Recovery Units. <table border="1"> <thead> <tr> <th colspan="3">GPT442MAA</th> </tr> <tr> <th>Temp.</th> <td colspan="2">167°F</td> </tr> <tr> <th>U-V</th> <td colspan="2">0.845 Ω</td> </tr> <tr> <th>V-W</th> <td colspan="2">0.859 Ω</td> </tr> <tr> <th>W-U</th> <td colspan="2">0.864 Ω</td> </tr> </thead> <tbody> <tr> <th colspan="3">JBA068MAF</th> </tr> <tr> <th>Temp.</th> <td>77°F</td> <td>167°F</td> </tr> <tr> <th>U-V</th> <td>0.163 \pm 7%Ω</td> <td>0.195 \pm 7%Ω</td> </tr> <tr> <th>V-W</th> <td>0.163 \pm 7%Ω</td> <td>0.195 \pm 7%Ω</td> </tr> <tr> <th>W-U</th> <td>0.163 \pm 7%Ω</td> <td>0.195 \pm 7%Ω</td> </tr> <tr> <th colspan="3">JQA048MAF</th> </tr> <tr> <th>Temp.</th> <td>77°F</td> <td>167°F</td> </tr> <tr> <th>U-V</th> <td>0.178 \pm 7%Ω</td> <td>0.212 \pm 7%Ω</td> </tr> <tr> <th>V-W</th> <td>0.178 \pm 7%Ω</td> <td>0.212 \pm 7%Ω</td> </tr> <tr> <th>W-U</th> <td>0.178 \pm 7%Ω</td> <td>0.212 \pm 7%Ω</td> </tr> <tr> <th colspan="3">JQC048MBC</th> </tr> <tr> <th>Temp.</th> <td>77°F</td> <td>167°F</td> </tr> <tr> <th>U-V</th> <td>0.113 \pm 7%Ω</td> <td>0.135 \pm 7%Ω</td> </tr> <tr> <th>V-W</th> <td>0.113 \pm 7%Ω</td> <td>0.135 \pm 7%Ω</td> </tr> <tr> <th>W-U</th> <td>0.113 \pm 7%Ω</td> <td>0.135 \pm 7%Ω</td> </tr> </tbody> </table> <ul style="list-style-type: none"> Check the IPM. If normal, replace the inverter board. Check coil and insulation resistors. 	GPT442MAA			Temp.	167°F		U-V	0.845 Ω		V-W	0.859 Ω		W-U	0.864 Ω		JBA068MAF			Temp.	77°F	167°F	U-V	0.163 \pm 7% Ω	0.195 \pm 7% Ω	V-W	0.163 \pm 7% Ω	0.195 \pm 7% Ω	W-U	0.163 \pm 7% Ω	0.195 \pm 7% Ω	JQA048MAF			Temp.	77°F	167°F	U-V	0.178 \pm 7% Ω	0.212 \pm 7% Ω	V-W	0.178 \pm 7% Ω	0.212 \pm 7% Ω	W-U	0.178 \pm 7% Ω	0.212 \pm 7% Ω	JQC048MBC			Temp.	77°F	167°F	U-V	0.113 \pm 7% Ω	0.135 \pm 7% Ω	V-W	0.113 \pm 7% Ω	0.135 \pm 7% Ω	W-U	0.113 \pm 7% Ω	0.135 \pm 7% Ω
GPT442MAA																																																															
Temp.	167°F																																																														
U-V	0.845 Ω																																																														
V-W	0.859 Ω																																																														
W-U	0.864 Ω																																																														
JBA068MAF																																																															
Temp.	77°F	167°F																																																													
U-V	0.163 \pm 7% Ω	0.195 \pm 7% Ω																																																													
V-W	0.163 \pm 7% Ω	0.195 \pm 7% Ω																																																													
W-U	0.163 \pm 7% Ω	0.195 \pm 7% Ω																																																													
JQA048MAF																																																															
Temp.	77°F	167°F																																																													
U-V	0.178 \pm 7% Ω	0.212 \pm 7% Ω																																																													
V-W	0.178 \pm 7% Ω	0.212 \pm 7% Ω																																																													
W-U	0.178 \pm 7% Ω	0.212 \pm 7% Ω																																																													
JQC048MBC																																																															
Temp.	77°F	167°F																																																													
U-V	0.113 \pm 7% Ω	0.135 \pm 7% Ω																																																													
V-W	0.113 \pm 7% Ω	0.135 \pm 7% Ω																																																													
W-U	0.113 \pm 7% Ω	0.135 \pm 7% Ω																																																													

***When measuring voltage and current of inverter power circuit, values can appear differently depending on tools and circuits, because voltage, power supply current, or inverter output has no sine waveform. Output voltage changes when inverter output voltage has a pulse wave pattern.**

1. If using a movable tester to check if inverter output voltage is constant (when comparing relative voltage between lines), always use an analog meter. Exercise particular caution if the inverter output frequency is low, when using a tester, where the change of measured voltage values is large between other lines, when virtually the same values appear, or in situations where it can be difficult to determine if an inverter failed.
2. Use a rectifier voltmeter ($\rightarrow|+$) if using a commercial frequency tester to measure inverter output values (when measuring absolute values). Accurate measuring values cannot be obtained with a general movable tester (for analog and digital mode).

Checking the Outdoor Unit Fan

If there is a fan error, check the items below and follow the corresponding procedure listed.

Check	Problem	Solution
1. Fan motor is not operating. (Does fan motor fail again when operation starts?)	Power supply is not correct.	Check wire connections at the breaker. Modify the power supply voltage if it is beyond permissible specifications.
	Wiring is wrong.	<ul style="list-style-type: none"> • Check wiring connections. • Check connector contacts. • Check that all components are firmly secured (tighten screws).
2. Fan motor vibration is excessive.		<ul style="list-style-type: none"> • Check polarity connection. • Check ground wiring and for short circuits.

Checking the Electronic Expansion Valves

Table 53: Pulse Signal Output Value and Valve Operation.

Output (ø) No.	Output State			
	1	2	3	4
ø1	ON	ON	OFF	ON
ø2	ON	ON	ON	OFF
ø3	OFF	OFF	ON	OFF
ø4	OFF	OFF	OFF	ON

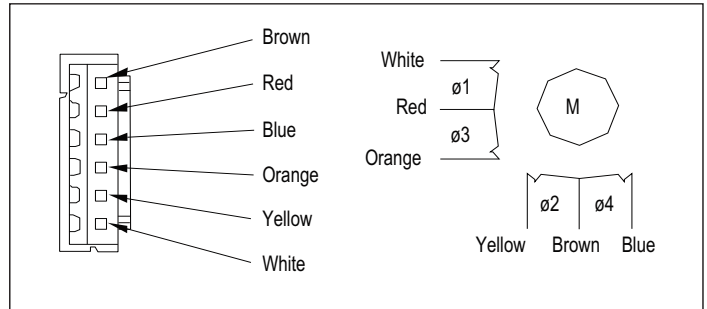

Output Pulse Sequence

- Valve close sequence: 4 → 3 → 2 → 1 → 4.
- Valve open sequence: 1 → 2 → 3 → 4 → 1.

1. If the EEV open position does not change, output phase will be off.
2. If the output phase is different or continuously on, the motor will start vibrating.

EEV Valve Operation

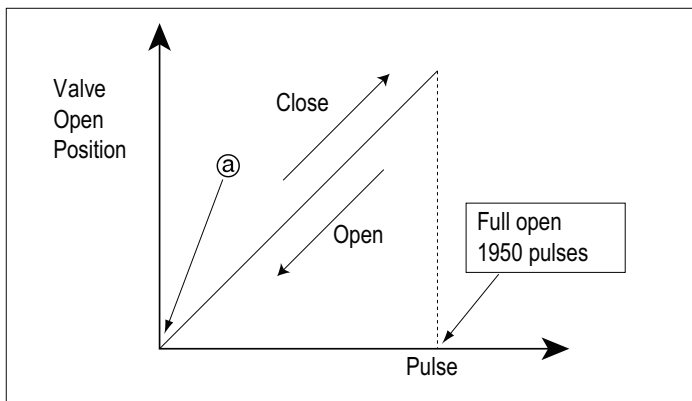

- At power on, open position signal is 1,400 pulses output, and valve position is set to "a" (see left). When the valve operates properly, noise and vibration will not occur. If the valve is closed, noise will be heard.
- Noise from EEV can be confirmed by touching the EEV surface with a screw driver and listening.
- If liquid refrigerant is present in EEV, noise will be lower.

CHECKING THE ELECTRONIC EXPANSION VALVES

Checking the Electronic Expansion Valves, continued.

Figure 35: EEV Coil and Casing (Outdoor Unit).

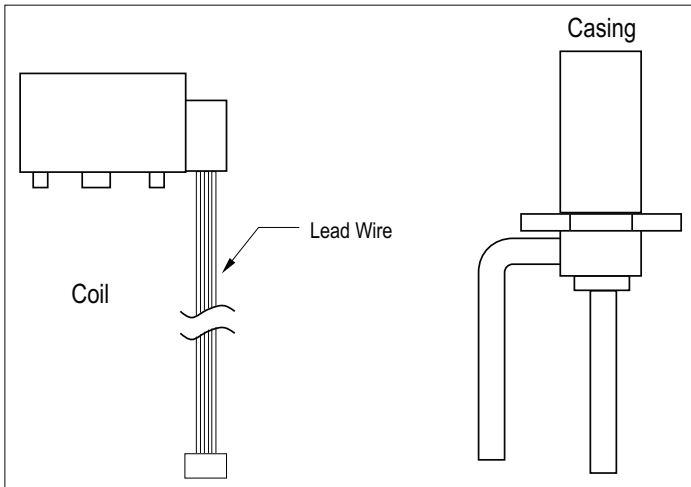
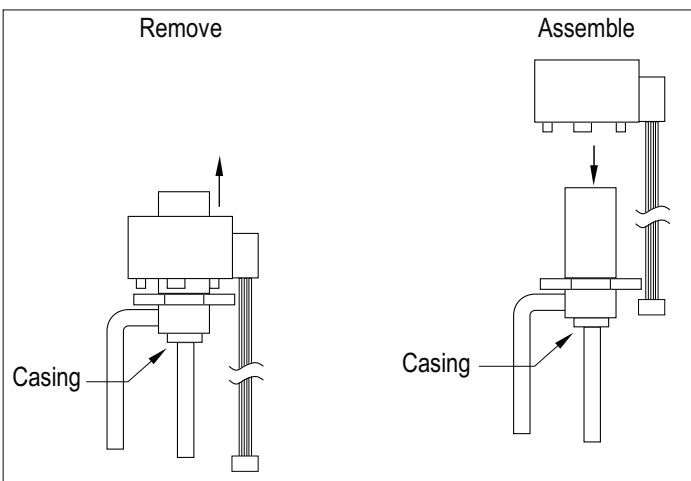

Figure 36: Removing and Assembling the Coil.



- Power off.
- Tightly grip the casing, and pull the coil up.
- During assembly, or when the coil is removed, take care not to bend the casing pipe.

Checking the Electronic Expansion Valves, continued.

Component	Problem	Diagnosis	Solution
Indoor Unit	Microcomputer circuit failure.	1. Remove the EEV connector from the control board, and connect testing LED. 2. With main power on, test pulse signal from EEV for 17 seconds. If LEDs do not turn on, or are continuously on, then the circuit is incorrect.	Check and replace indoor unit control board.
	EEV is closed, but valve is leaking.	1. Operate one indoor unit in fan mode, and then operate another indoor unit in cooling mode. 2. Check the liquid piping temperature of the indoor unit in fan mode (through the outdoor unit control board). 3. Check if the fan is rotating and the EEV is closed. If there is a leak, the liquid piping temperature at the indoor unit in fan mode will be low. If the measured temperature is very low when compared to the suction temperature (that is displayed at the remote controller), then the EEV is not fully closed.	If the amount that is leaking is excessive, replace the EEV.
	EEV motor coil has shorted out or has disconnected.	1. Check the resistance between the coil terminals (brown-white, brown-yellow, brown-orange, brown-blue). 2. If the estimated resistance value is 150 ± 10 , then the EEV is normal.	Replace EEV.
Indoor Unit / Outdoor Unit	EEV locks up.	Check for a locked EEV: if the system is in a no-load state, if the driving motor is rotating, and a clicking sound can be heard.	
Outdoor Unit	EEV motor coil has shorted out or has disconnected.	1. Check the resistance between coil terminal (red-white, red-yellow, red-orange, red-blue). 2. If the estimated resistance value is 52 ± 3 , then the EEV is normal.	

Checking the Inverter Insulated-Gate Bipolar Transistor Module

Figure 37: ARUN024GSS4, ARUN038GSS4, ARUN048GSS4, ARUN053GSS4 Heat Pump Inverter IGBTM.

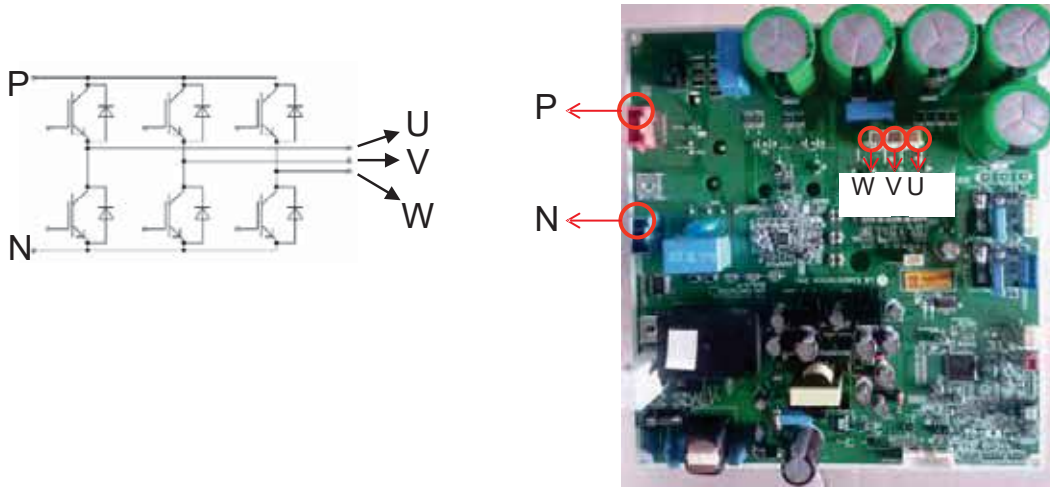
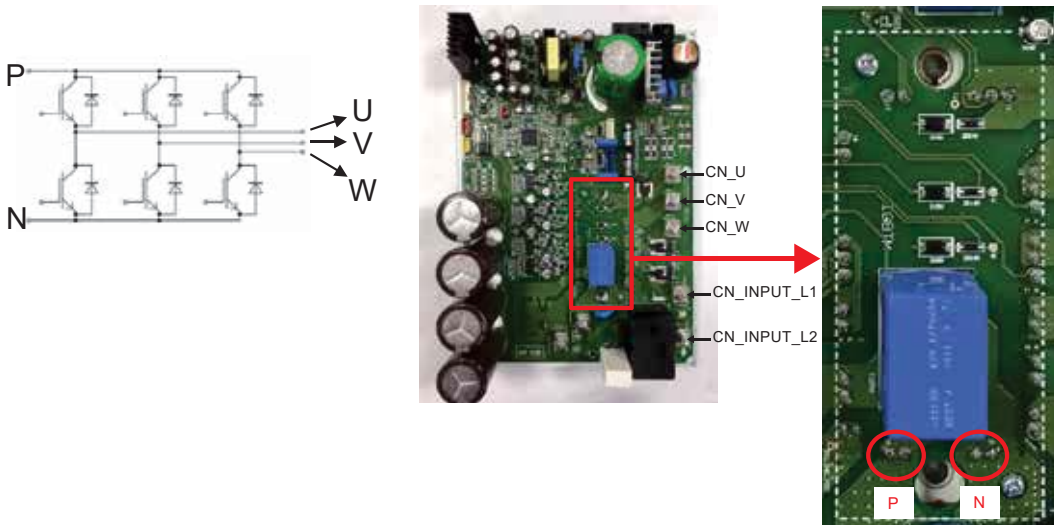

Figure 38: ARUN060GSS4 Heat Pump Inverter and ARUN060GSS4 Heat Recovery Inverter IGBTM.



1. Shut off main power. After main power is shut off, wait at least ten (10) minutes until inverter compressor PCB DC voltage is discharged.
2. Disconnect DC_Link connector and U, V, W compressor connectors connected to the inverter PCB..

⚠ WARNING

After switching off the main power supply and verifying that the DC voltage was discharged, wait for at least ten (10) minutes before checking the electrical components in the control box. There is risk of electric shock, physical injury or death.

3. Set the multi-tester to diode mode.
4. Measured value must be 0.2 ~ 0.6 V as shown in the table on the next page.
5. If the measured value is different than what is listed in the table on the next page, then set the multi-tester to resistance mode and measure again. If the value is too low (0Ω) or too high (hundreds MΩ), the inverter PCB is damaged and needs to be replaced.
6. If the IGBTM is damaged, check if the compressor needs to be replaced.

Checking the Inverter IGBTM, continued.

Table 54: Checking the Inverter IGBTM.

	P Terminal: Black (-)	N Terminal: Red (+)
U Terminal : Red (+)	0.2 ~ 0.6 V	-
V Terminal : Red (+)	0.2 ~ 0.6 V	-
W Terminal : Red (+)	0.2 ~ 0.6 V	-
U Terminal : Black (-)	-	0.2 ~ 0.6 V
V Terminal : Black (-)	-	0.2 ~ 0.6 V
W Terminal : Black (-)	-	0.2 ~ 0.6 V

Red (+) and Black (-) are the multi-tester terminals.

Checking the High / Low Pressure Sensors

Connect the manifold gauge to the outdoor unit service valve, and compare the high pressure sensor output to the low pressure sensor output to check for errors. Compare the pressure sensor outputs to the manifold gauge pressure outputs using the table below.

Figure 39: Pressure Sensor Output Characteristics.

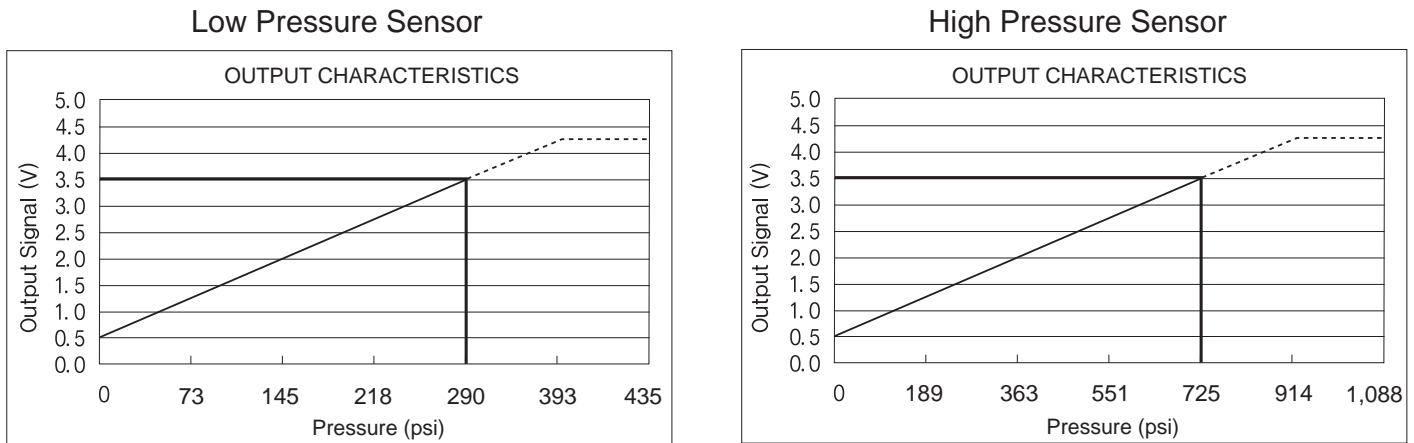

1. If the manifold gauge pressure reads 0 to 14.22 psi, it indicates the pressure dropped due to a refrigerant leak. Find the leak and repair it.
2. If the difference between the high and low pressure outputs is around 14.22 psi, the pressure sensor is normal.
3. If the difference between the high and low pressure outputs is >14.22 psi, the pressure sensor is damaged and needs to be replaced.

Figure 40: Pressure Sensor Schematic.

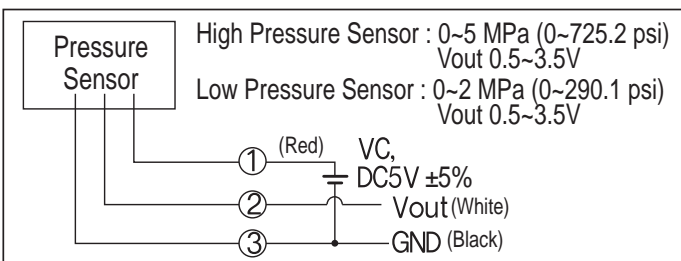

See the pressure sensor schematic at left. DC 5V will be measured between red and black wires. DC voltage measured between white and black wire corresponds to charts above.

CHECKING THE OUTDOOR FAN, FOUR-WAY REVERSE VALVE, AND TEMPERATURE SENSORS

Checking the Outdoor Fan

1. The inverter motor controls the number of rotations on the outdoor unit fan.
2. The high / low pressure sensors control the outdoor unit fan after compressor operation.
3. Even if the compressor is on, the outdoor unit fan will not operate due to low capacity, or if the outdoor temperature is low. This is normal, and the outdoor unit fan will begin to operate when the system reaches setpoint.

Checking the Four-Way Reverse Valve

1. The four-way reverse valve must be OFF before the outdoor and indoor units are powered up and turned on.
2. The four-way reverse valve must be OFF during cooling, defrost, and oil recovery operation. The four-way reverse valve must be ON during heating operation.
3. When switching from cooling to heating operation, the four-way valve position changes during the three (3) minute mode change restart.
4. To check if the four-way reverse valve is operating in cooling or heating mode, touch the piping surface of the low pressure service valve.
5. See diagram at right for the refrigerant flowchart of the four-way reverse valve.
6. Insulation resistance between the four-way reverse valve connection and the coil must be >100 MΩ (measure with a DC mega-tester [DC 500V]).

Figure 41: Refrigerant Flowchart of the Four-Way Reverse Valve.

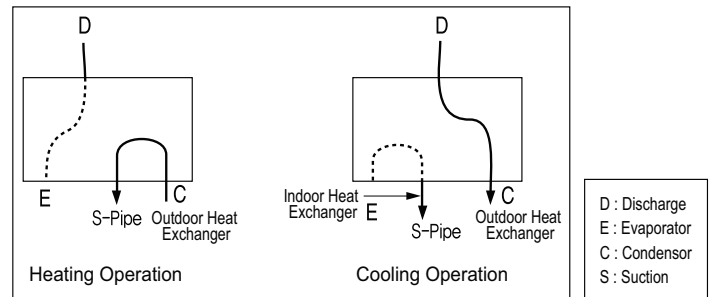

Checking the Temperature Sensors

1. Outdoor Temperature Sensor: TH1
2. Discharge Pipe (D-pipe) Temperature Sensor: TH2
 - Check the temperature sensor installation and connections.
 - Check if the connection contact of the temperature sensor is normal.
 - Measure the resistance of temperature sensor.
3. Pipe Temperature Sensor : TH3

Table 55: Temperature Sensor Resistance Values.

Temperature Sensor	TH1	TH2	TH3
Resistance	10 kΩ ± 1% @ 77°F	200 kΩ ± 1% @ 77°F	5 kΩ ± 1% @ 77°F
	1.07 kΩ ± 3.3% @ 185°F	28 kΩ ± 7.7% @ 185°F	535 Ω ± 3.3% @ 185°F

⚠ WARNING Please refer to the Safety Precautions on pages 4-7 for more detail to prevent injury or death regarding the operation and service troubleshooting of the Multi V product.

General Information

LG VRF system's core logic uses error codes to indicate that an abnormal operation occurred. Error codes help guide a trained service technician to identify why and what caused the error to display, and help track the frequency of malfunction occurrences.

There are four (4) levels of error code responses; the system responds accordingly, depending on the severity of the malfunction assigned to the malfunction. The level of responses range from "notify and keep operating" (Level 4), to "immediate system shutdown" (Level 1).

All error codes can be viewed at the outdoor unit seven segment display (SSD) and with LGMV software. If an error codes shows on one (1) or more indoor unit zone controllers, it will display on LGMV, central controllers, BMS, or any other LG device connected to Comm bus - Internet A/B. Indoor unit error code notifications will display differently based on location of the problem.

Level 4 Responses

Level 4 responses display the error code, but the system continues to operate (operate indefinitely). When the malfunction is fixed, the error code remains until the master outdoor unit's microprocessor is reset, and operation has resumed for 130 minutes without the malfunction reoccurring.

Level 3 Responses

Level 3 responses display the error code on all zone controllers, central controllers, and on BMS systems. For Level 3 responses, the Multi V system will shut down for three (3) minutes, and then the master microprocessor in the outdoor unit will automatically restart the system.

If the malfunction reoccurs up to a total of nine (9) times within one (1) hour, the system will display the error code, shut down, and restart again each time. If the malfunction occurs a tenth (10th) time within the same one (1) hour, the system shuts down permanently, assigning the error to a Level 1 response that requires a manual restart. The error code displays on the zone controllers and central controllers until the malfunction is fixed.

Level 2 Responses

Level 2 responses are communications related errors only. Level 2 responses activate after ten (10) attempts to communicate have occurred. After communications have been re-established, the error codes display for one (1) minute. If the communications are restored, then the error code disappears. If the communication is lost within one (1) minute, the error code remains.

Error codes for Level 2 responses stop appearing on the zone and central controllers as soon as communications are restored, without the need to reset power at the Master outdoor unit or to restart the entire system.

Multi V error codes for Level 2 responses appear where the problem occurs, and time limits differ depending on type:

1. Communications lost between outdoor unit PCBs – no time delay.
2. Communications lost between the indoor unit and the outdoor unit for three (3) minutes.
3. Communications lost between the indoor unit and heat recovery unit for ten (10) seconds.
4. Communications lost between outdoor unit external PCBs for ten (10) seconds.

Level 1 Responses

Many Level 1 responses call for an immediate system shutdown, and, in almost all abnormal operational situations, occur after the algorithm monitoring system verifies that the malfunction is real (to avoid nuisance alarms and false positives). Level 1 responses are displayed at zone controllers, central controllers, BMS, LGMV, and the outdoor unit SSD. They cannot be cleared until the problem that caused it is fixed.

Before a Level 1 response is assigned, the Multi V algorithm initially assigns a Level 3 response to any system malfunction that is not communications related. The system follows Level 3 protocol until the tenth (10th) time a malfunction occurs, at which time the system shuts down, the malfunction changes from Level 3 to Level 1, and a manual restart is required. The entire Level 3 auto restart to Level 1 shut down sequence will repeat until the malfunction is fixed.

Note:

For more information on Multi V Levels and error codes, see the troubleshooting pages in this section, and contact an LG trained technician.

ERROR CODE TABLES

⚠ WARNING Please refer to the Safety Precautions on pages 4-7 for more detail to prevent injury or death regarding the operation and service troubleshooting of the Multi V product.

Error Code Display

The seven segment display on the main board displays error codes. Error codes are 3 or 4 digit numbers. The rightmost number designates the ODU frame (1=Master; 2=Slave1; 3=Slave2). The other two or three digits indicate the error.

Examples: 211 = Error No. 21 on master unit; 212 = Error No. 21 on slave 1 unit; 213 = Error No. 21 on slave2 unit, 1051 = Error No. 105 on master unit.

- If two or more errors occur simultaneously, the lower error code number is displayed first.
- After error is resolved, the error code disappears.

Figure 42: Example of an Error Code.

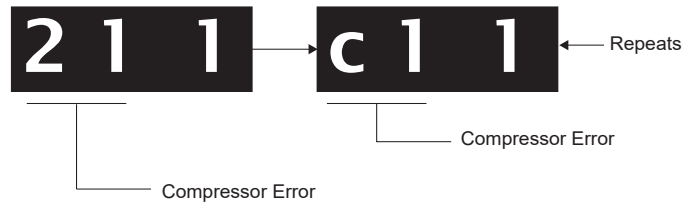

Nomenclature Definitions

- MICOM: Non-volatile memory chip where unit setup information is stored.
- EEPROM: Non-volatile memory chip where device identification, size, and factory defined default component operating parameters are stored.

See the error code tables below and on the following pages. Pages after the tables include detailed information for the error codes used for Multi V systems.

Table 56: Error Codes.

Error Code	Description	Details	
Indoor Unit	0 1	Indoor unit return air or optional remote wall temperature sensor communications error.	Indoor unit air temperature sensor disconnected or shorted. (Check the wiring, connection on the indoor unit PCB, then check the thermistor.)
	0 2	Indoor unit inlet pipe temperature sensor communication error.	Indoor unit inlet pipe temperature sensor is disconnected or shorted. (Check the connection on the indoor unit PCB, then check the thermistor.)
	0 3	Communication error between zone controller and indoor unit.	Indoor unit PCB is not receiving communications signal from zone controller.
	0 4	Indoor unit drain overflow error.	Drain pump and/or flow switch is/are malfunctioning. Also check drain line for obstructions.
	0 5	Communication error between outdoor unit PCB and indoor unit PCB.	Indoor unit communications PCB is not receiving signal from outdoor unit communications PCB for more than 5 minutes. Check indoor unit PCB for issues.
	0 6	Indoor unit outlet pipe temperature sensor error.	Indoor unit outlet pipe temperature sensor is disconnected or shorted. (Check the connection on the indoor unit PCB, then check the thermistor.)
	0 7	Indoor units are not operating in the same mode. (Heat pump applications only)	Different operation mode between indoor units.
	0 9	Indoor unit EEPROM error.	<ul style="list-style-type: none"> • Communication error between the indoor unit PCB board and its option card. (The option card is about 1' x 1' and is plugged into the indoor unit PCB board. Check connection between the two.) • Communication error between EEPROM on indoor unit main PCB. • Indoor unit EEPROM data is not available.
1 0	Indoor unit BLDC fan motor communications error.	<ul style="list-style-type: none"> • Fan motor has been removed or is defective. Refer to the resistance and voltage check charts in this service manual. • The system has detected the fan motor is not spinning. • On new installs, verify installation manual and paperwork were removed from fan discharge shroud during installation. • Check the wiring plug and connections (if applicable). 	

⚠ WARNING Please refer to the Safety Precautions on pages 4-7 for more detail to prevent injury or death regarding the operation and service troubleshooting of the Multi V product.

Table 57: Error Codes, continued.

Error Code			Description	Details
Indoor Unit	2	3	0	Refrigerant leak sensor error. Only displayed at the indoor unit and its wired remote controller. <ul style="list-style-type: none"> • Refrigerant leak sensor error; sensor is malfunctioning. • Error will also be displayed if the function is enabled on the wired remote controller, and there is not a sensor installed. • Refrigerant leak is detected when >6,000 ppm. • Enable the function through the function code on the remote controller. • Operation stop. • Solenoid valve closes on the indoor unit side. • CH230 is displayed. If the communication baud is 1,200 bps, then only the zone controller can display the CH230; central controller cannot display the error due to lack of information. • Buzzer rings 2 long buzzes every 1 second. Ringing stops when there is an input from the controller. (If there is a hard lock, then only the controller can make the hard lock to stop buzzing. If leak sensor measures under 1.5V, then it is considered normal and the buzzing stops. • To release the error, power needs reset.
	2	3	7	Communication error between outdoor unit PCB and indoor unit PCB. Only displayed at the indoor unit and its wired remote controller. <ul style="list-style-type: none"> • Indoor unit communications PCB is not receiving signal from outdoor unit communications PCB for more than 3 minutes. Check RS-485 communications for issues.
	2	3	8	Communication error between outdoor unit PCB and indoor unit PCB. Displayed at the indoor unit and its wired remote controller. <ul style="list-style-type: none"> • Indoor unit communications PCB is not receiving signal from outdoor unit communications PCB for more than 3 minutes. Check outdoor unit PCB for issues.
Outdoor Unit	2		1	Outdoor unit inverter board IPM fault error. Error code is determined by overcurrent in any one phase of compressor. <ul style="list-style-type: none"> • Overcurrent conditions have been detected at the inverter compressor (U,V,W). • Compressor motor or insulation has been damaged. • IPM has overheated due to damage or disconnection of the heat sink fan, or the heat sink has been disassembled. • Inverter compressor terminal has been disconnected or loosened. • Inverter PCB assembly has been damaged. • Low input current to the outdoor unit. Damaged inverter board – input voltage too low. For 208-230V: On 068 compressors = 143A for a minimum of 3μs; on 048 compressors = 96A for a minimum of 3μs.
	2		2	Outdoor unit inverter PCB AC input overcurrent (RMS) error. <ul style="list-style-type: none"> • Overcurrent of outdoor unit inverter board PCB. • Under voltage. • Refrigerant flow restriction from defective EEV. • Refrigerant charge is too high (overcharged).
	2		3	Low or high DC voltage sensed at the outdoor unit inverter compressor DC link. <ul style="list-style-type: none"> • There is a capacitor that is not working properly, or the voltage at the capacitor is out of range. System shut off because outdoor unit inverter compressor DC link voltage fell below 50V or exceeded 550V for a minimum of 250μs. • Start diagnosis at the inverter socket on the outdoor unit noise filter PCB. • Disconnected DC link. • Damaged electrical condenser component (serving capacitor) on inverter driver board. Improper wiring at DC link terminal or disconnected contact.
	2		4	System has been turned off by the outdoor unit high pressure switch. <ul style="list-style-type: none"> • Outdoor unit high pressure switch error. • Check the connection on the outdoor unit PCB. • Use chart in Troubleshooting section of the manual to check signal output (V DC) versus actual pressure.
	2		5	Input voltage to the outdoor unit is too high or too low. <ul style="list-style-type: none"> • Outdoor unit has an input voltage of ≤140V or ≥300V (for 208-230V units).
	2		6	Outdoor unit inverter compressor operation error. <ul style="list-style-type: none"> • Inverter compressor failed to start.

Error Codes

ERROR CODE TABLES



WARNING Please refer to the Safety Precautions on pages 4-7 for more detail to prevent injury or death regarding the operation and service troubleshooting of the Multi V product.

Table 58: Error Codes, continued.

Error Code	Description	Details
Outdoor Unit	2 9 Outdoor unit inverter compressor overcurrent error.	<ul style="list-style-type: none"> Outdoor unit inverter compressor current draw is too high. Compressor defect and restriction in refrigerant piping are possible causes.
	3 2 Excessive increase in outdoor unit inverter compressor gas discharge temperature.	<ul style="list-style-type: none"> System shutdown happens when discharge pipe temperature rises >115°C (239°F) for 10 seconds, or compressor temperature equals 105°C (221°F) for 10 seconds. Check the inverter compressor discharge pipe temperature sensor. Check for low refrigerant / leaks. Check for a defective EEV. Check for a defective liquid spray valve.
	3 4 Outdoor unit compressor high pressure safety tripped.	<ul style="list-style-type: none"> Shutdown due to if compressor high pressure is >4,000 kPa (580 psi) for ten (10) seconds. Check the high pressure sensor, indoor unit or outdoor unit fan(s), refrigerant, EEV, service valve (can be clogged); check for defective outdoor unit PCB, indoor unit pipe temperature sensor, or hot gas valve. Also, outdoor unit could not have enough clearance (cooling operation), or indoor unit filter can be clogged (heating operation).
	3 5 Outdoor unit low side pressure below allowable limits.	<ul style="list-style-type: none"> System will shut down when an abnormal low pressure condition occurs. Shut down occurs when the compressors inverter frequency <30Hz = low <110 kPa for 1 minute. When operating in cooling mode: Low side pressure <400 kPa for 1 minute; High side pressure is <2,200 kPa. Check for refrigerant leaks (low refrigerant charge), or a defective indoor unit EEV. When operating in heating mode: Low side pressure <230 kPa for 1 minute; High side pressure is <1,800 kPa. Check for refrigerant leaks (low refrigerant charge), or a defective outdoor unit EEV.
	3 6 Outdoor unit inverter low compression ratio.	<ul style="list-style-type: none"> Outdoor unit is experiencing a problem developing compressor lift. Error is calling out low compression ratio. System will shut down and display error code "CH36". Error occurs if the compression ratio is <1.6 (scroll compressor) or <1.8 (rotary compressor) for 2 minutes following a change in position of the reversing valve (either direction), and for 5 minutes following a compressor start. Pressure differential: <400kPa (scroll compressor), and 500kPa (rotary compressor).
	4 0 Outdoor unit inverter compressor current transducer (CT) sensor error.	Outdoor unit inverter compressor current transducer (CT) detection sensor disconnected or shorted.
4 1 Outdoor unit inverter compressor discharge pipe temperature sensor error.	<ul style="list-style-type: none"> Error can also occur if the system is operating in cooling at extremely low temperatures with no low ambient kit. Compressor discharge pipe temperature sensor (TH3) is not installed or connected properly. Defective compressor discharge pipe sensor (TH3) (opened or shorted). Defective outdoor unit PCB. Standard values of sensor resistance at different temperatures (5% variation): 50°F = 362 kΩ, 77°F = 200 kΩ, 122°F = 82 kΩ, 212°F = 18.5 kΩ. Other temperature sensor resistance values: 77°F = 10 kΩ ± 1%; 77°F = 5 kΩ ± 1%; 77°F = 200 kΩ ± 1%; 185°F = 1.07 kΩ ± 3.3%; 185°F = 535 kΩ ± 3.3%; 185°F = 28 kΩ ± 7.7%. 	



⚠ WARNING Please refer to the Safety Precautions on pages 4-7 for more detail to prevent injury or death regarding the operation and service troubleshooting of the Multi V product.

Table 59: Error Codes, continued.

Error Code		Description	Details
Outdoor Unit	4 2	Outdoor unit low pressure sensor error.	<ul style="list-style-type: none"> • Check the connection on the outdoor unit PCB. • Thermistor shorted or opened.
	4 3	Outdoor unit high pressure sensor error.	<ul style="list-style-type: none"> • Check for 12 V DC between 12 V and GND (red to black) for 5 V DC. • Check the Signal to GND (white to black) and use correct chart from Troubleshooting section to compare with actual system pressure.
	4 4	Outdoor unit ambient temperature sensor error.	• Check the connection on the outdoor unit PCB.
	4 5	Outdoor unit heat exchanger pipe temperature sensor.	• Thermistor shorted or opened.
	4 6	Outdoor unit suction pipe temperature sensor error.	<ul style="list-style-type: none"> • Check the connection on the outdoor unit PCB. • Thermistor shorted or opened. • Check suction sensor in cooling mode; check hot gas sensor located near the heat exchanger in heating mode.
	5 0	Outdoor unit loss of phase.	Input power line connection is / are missing for the outdoor unit.
	5 1	Combination ratio is out of range.	The total of the nominal indoor unit capacity is less than 50% or more than 130% of the nominal outdoor unit capacity.
	5 2	Communication error between outdoor unit main PCB and inverter PCB.	<ul style="list-style-type: none"> • Communication error between main PCB and inverter PCB. • Check connections at both sockets. • Inspect interconnecting cable for wear.
	5 3	Communication error between outdoor unit main PCB and indoor unit(s) PCB.	<ul style="list-style-type: none"> • Check if outdoor unit to indoor unit(s) communications cable disconnected or shorted. • Check A terminals are connected to indoor unit A(3) (5 on 3 x 3 cassette) terminals; B(4) (6 on 3 x 3 cassette) terminals.
	5 7	Outdoor unit main PCB and inverter PCB communication error.	Outdoor unit inverter PCB is not receiving signal from main PCB.
	6 0	Outdoor unit inverter PCB EEPROM error.	<ul style="list-style-type: none"> • Verify the EEPROM is present and in the socket correctly. • Check if all pins are in and are not bent. • Check if notch in the chip lines up with the arrow on the socket.
	6 2	High temperature at the outdoor unit inverter heat sink.	System shut off because of high temperatures at the outdoor unit inverter heat sink.
	6 5	Outdoor unit inverter heat sink temperature sensor error.	<ul style="list-style-type: none"> • Check the connection on the outdoor unit PCB. • Thermistor shorted or opened. • Check for 12 V DC between 12 V and GND (red to black) for 5 V DC. • Check the Signal to GND (white to black) and use correct chart from Troubleshooting section to compare with actual system temperature.
	6 7	Outdoor unit fan has locked up.	No airflow.
	7 1	Outdoor unit inverter CT sensor error.	Outdoor unit is restricted.
8 6	Outdoor unit main PCB onboard EEPROM error.	<ul style="list-style-type: none"> • Verify the EEPROM is present and in the socket correctly. • Check if all pins are in and are not bent. • Check if notch in the chip lines up with the arrow on the socket. 	

Error Codes

ERROR CODE TABLES



⚠ WARNING Please refer to the Safety Precautions on pages 4-7 for more detail to prevent injury or death regarding the operation and service troubleshooting of the Multi V product.

Table 60: Error Codes, continued.

Error Code				Description	Details
Outdoor Unit	1	1	3	Outdoor unit liquid pipe temperature sensor error.	<ul style="list-style-type: none"> • Check the connection on the outdoor unit PCB. • Thermistor shorted or opened.
	1	1	4	Outdoor unit subcooling inlet temperature sensor error.	<ul style="list-style-type: none"> • Check for 12 V DC between 12 V and GND (red to black) for 5 V DC.
	1	1	5	Outdoor unit subcooling outlet temperature sensor error.	<ul style="list-style-type: none"> • Check the Signal to GND (white to black) and use correct chart from Troubleshooting section to compare with actual system temperature.
	1	5	0	Outdoor unit compressor discharge superheat not satisfied. (ARUN / ARUB60GSS4 only)	<p>Code indicates that based on current superheat measurements, there is a high possibility of liquid refrigerant flooding back and damaging the compressor.</p> <ul style="list-style-type: none"> • Outdoor unit compressor discharge superheat not satisfied for ≥5 minutes. • Code can only occur when the outdoor is operating in cooling mode (all indoor units must be in cooling mode; error cannot occur during simultaneous operation). • After at least 10 minutes of compressor operation, the master outdoor unit microprocessor will calculate the system's compressor superheat. If at any time during compressor operation where all indoor units in thermal on are in cooling mode and the compressor superheat falls <4.8°F (<3°C) for ≥5 minutes, there is a high probability that liquid could flood back to the inlet of the compressor scroll, resulting in compressor damage. • If error occurs 3 times within any 1 hour period of compressor operation, the system will shut down and remain off. A manual restart will be necessary.
	1	5	1	The difference between the high and low pressure is too low.	<ul style="list-style-type: none"> • Not enough pressure difference between high and low. Function error of outdoor unit four-way reversing valve.



⚠ WARNING Please refer to the Safety Precautions on pages 4-7 for more detail to prevent injury or death regarding the operation and service troubleshooting of the Multi V product.

Table 61: Error Codes, continued.

Error Code				Description	Details	
Heat Recovery Unit	-	5	1	C + No. of HR Unit Capacity of indoor units connected to the heat recovery unit exceeds allowable limits.	<p>The amount of nominal cooling capacity of indoor units connected to a heat recovery unit, or a heat recovery unit port, or grouped heat recovery unit port is excessive. After auto-pipe detection is complete, wait 5 minutes, then verify connected capacity. System will display error if:</p> <ul style="list-style-type: none"> • The heat recovery unit port addresses are all unique, then >54 Mbh single indoor unit connected; >54 Mbh total of multiple indoor units connected. • If 2 heat recovery unit port addresses are the same and the ports are twinned; >108 Mbh total of multiple indoor units are connected. • If 3 heat recovery unit port addresses are the same and the ports are all connected, >162 Mbh total of multiple indoor units connected. • If the total connected indoor unit nominal capacity exceeds 192 Mbh for a single heat recovery unit. • Error code displays on the outdoor unit SSD, the heat recovery unit SSD, or in LGMV. 	
	2	0	0	1	Auto pipe search failure.	Auto piping procedure did not complete properly.
	2	0	1	C + No. of HR Unit	Heat recovery unit liquid sensor error. (C = Heat recovery unit + Heat recovery unit number).	Disconnection or short circuit of heat recovery unit liquid pipe sensor.
	2	0	2		Heat recovery unit subcooling pipe inlet sensor error. (C = Heat recovery unit + Heat recovery unit number).	Disconnection or short circuit of heat recovery unit subcooling pipe inlet sensor.
	2	0	3		Heat recovery unit subcooling pipe outlet sensor error. (C = Heat recovery unit + Heat recovery unit number).	Disconnection or short circuit of heat recovery unit subcooling pipe outlet sensor.
	2	0	4		Communication error between outdoor unit and heat recovery unit. (C = Heat recovery unit + Heat recovery unit number).	Outdoor unit does not receive signal from heat recovery unit.
	2	0	5		Communication error between heat recovery unit (2A Series) and the 485 modem. The 2A Series heat recovery unit applies only to heat recovery systems communicating at a baud rate of 9,600 bps. <ul style="list-style-type: none"> • The 485 modem is the communications style on the bus that is 1e outdoor unit to many indoor units. 	<ul style="list-style-type: none"> • Communication problem occurred between the heat recovery unit PCB and the connection to the communications bus. • Error displays if the outdoor unit signal is not received for three (3) minutes. The error clears after the signal is received from the modem. (2A Series Heat Recovery Units.)
	2	0	6		Duplicate address error of the heat recovery unit (2A Series). <ul style="list-style-type: none"> • The 2A Series heat recovery unit applies only to heat recovery systems communicating at a baud rate of 9,600 bps. • The 485 modem is the communications style on the bus that is 1e outdoor unit to many indoor units. 	<ul style="list-style-type: none"> • A heat recovery unit address is duplicated for 485 communication. • There are two heat recovery units with one or more HEX addresses that are the same. • Adjust the hex address dial found on the heat recovery units.
2	4	2	Network error of central controller.		Inability of the central controller to receive information from the outdoor unit.	

ERROR CODES

Error Nos. 01, 02, 06

⚠ WARNING Please refer to the Safety Precautions on pages 4-7 for more detail to prevent injury or death regarding the operation and service troubleshooting of the Multi V product.

Error No.	Description	Details	Causes
01	Indoor unit return air or optional remote wall temperature sensor communications error.	Sensor has disconnected or short circuited. Use the OHM and voltage check charts.	<ol style="list-style-type: none"> 1. Problem with the sensor. 2. Connections on indoor unit PCB are wrong. 3. Indoor unit PCB has failed.
02	Indoor unit inlet pipe temperature sensor communication error.		
06	Indoor unit outlet pipe temperature sensor error.		

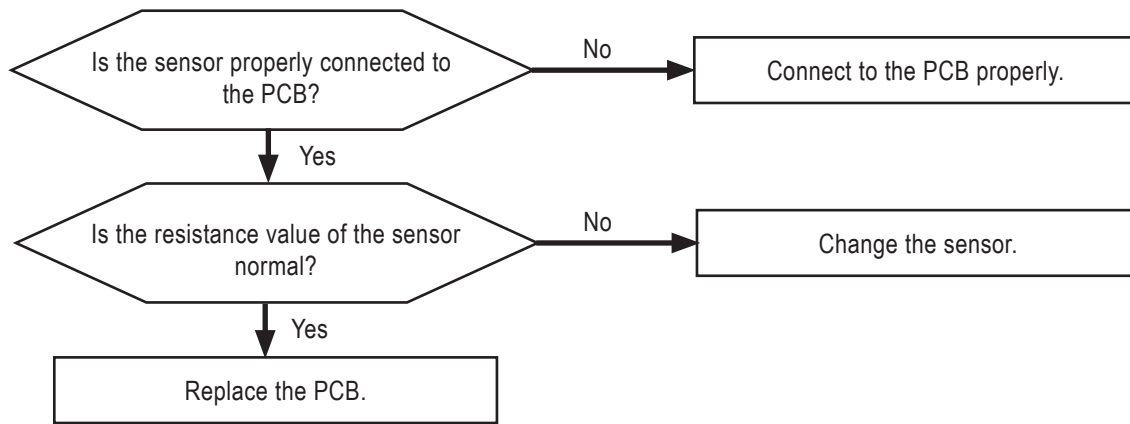

- If the value is >100kΩ (open) or <100Ω (short), there is an error.
- Sensor resistance value will vary with the temperature. See below for the resistance values according to temperature (±5% tolerance).
- Air temperature sensor: 50°F = 20.7 kΩ, 77°F = 10 kΩ, 122°F = 3.4 kΩ.
- Pipe temperature sensor: 50°F = 10 kΩ, 77°F = 5 kΩ, 122°F = 1.8 kΩ.



← CN-ROOM: Indoor Air Temperature Sensor
 ← CN-PIPE IN: Pipe Inlet Temperature Sensor
 ← CN-PIPE OUT: Pipe Outlet Temperature Sensor



Measure the resistance of outlet pipe temperature sensor.

Note:
 Images here are representative of system components. Actual component appearance depends on model and system type.

⚠ WARNING Please refer to the Safety Precautions on pages 4-7 for more detail to prevent injury or death regarding the operation and service troubleshooting of the Multi V product.

Error No.	Description	Details	Causes
03	Communication error between zone controller and indoor unit	Indoor unit PCB has not received communications signal from zone controller.	<ol style="list-style-type: none"> 1. Zone controller error. 2. Indoor unit PCB error. 3. Connection error or connection wrong. 4. Transmission cable error.

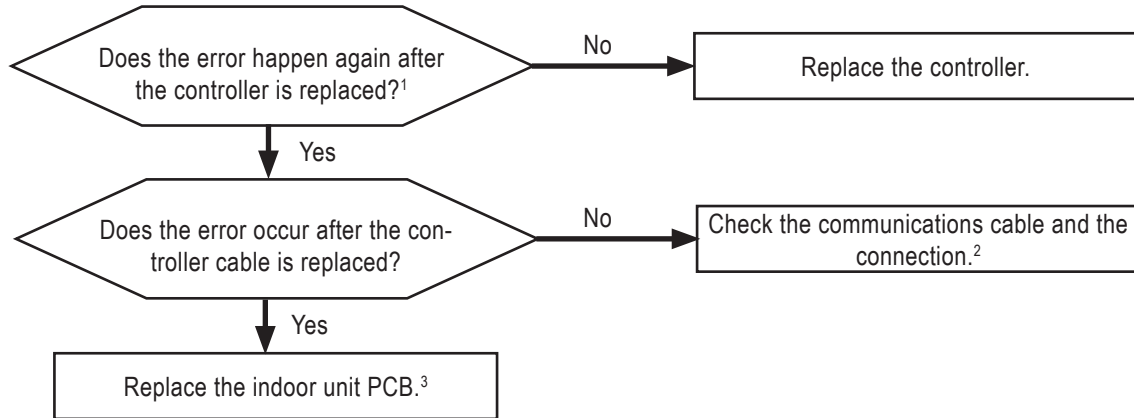

¹If there isn't a controller to replace, use an operating controller from another indoor unit.

²Plug the controller directly into the indoor unit PCB. If the error code does not come back after several minutes, the cable needs to be replaced. Check the cable because the connection could be in error. Check for cable extensions. Also, check distances between the communication cable and main electrical wiring. Ensure that the cable and wiring are at safe distances from one another to avoid being affected by electromagnetic waves.

³After replacing the indoor unit PCB, perform the auto addressing procedure, and input unit address if system includes a controller. (All connected indoor units must be turned ON before initiating the auto addressing procedure.)



CN-REMO: Remote controller connection

* The PCB can differ from model to model.

Note:

Images here are representative of system components. Actual component appearance depends on model and system type.



Checking communication cable connection

ERROR CODES

Error No. 04

⚠ WARNING Please refer to the Safety Precautions on pages 4-7 for more detail to prevent injury or death regarding the operation and service troubleshooting of the Multi V product.

Error No.	Description	Details	Causes
04	Indoor unit drain overflow error.	Drain pump and / or float switch is / are malfunctioning. Also check if the drain line is obstructed.	<ol style="list-style-type: none"> 1. Drain pump / float switch error. 2. Improper drain pipe location, clogged drain pipe. 3. Indoor unit PCB error.

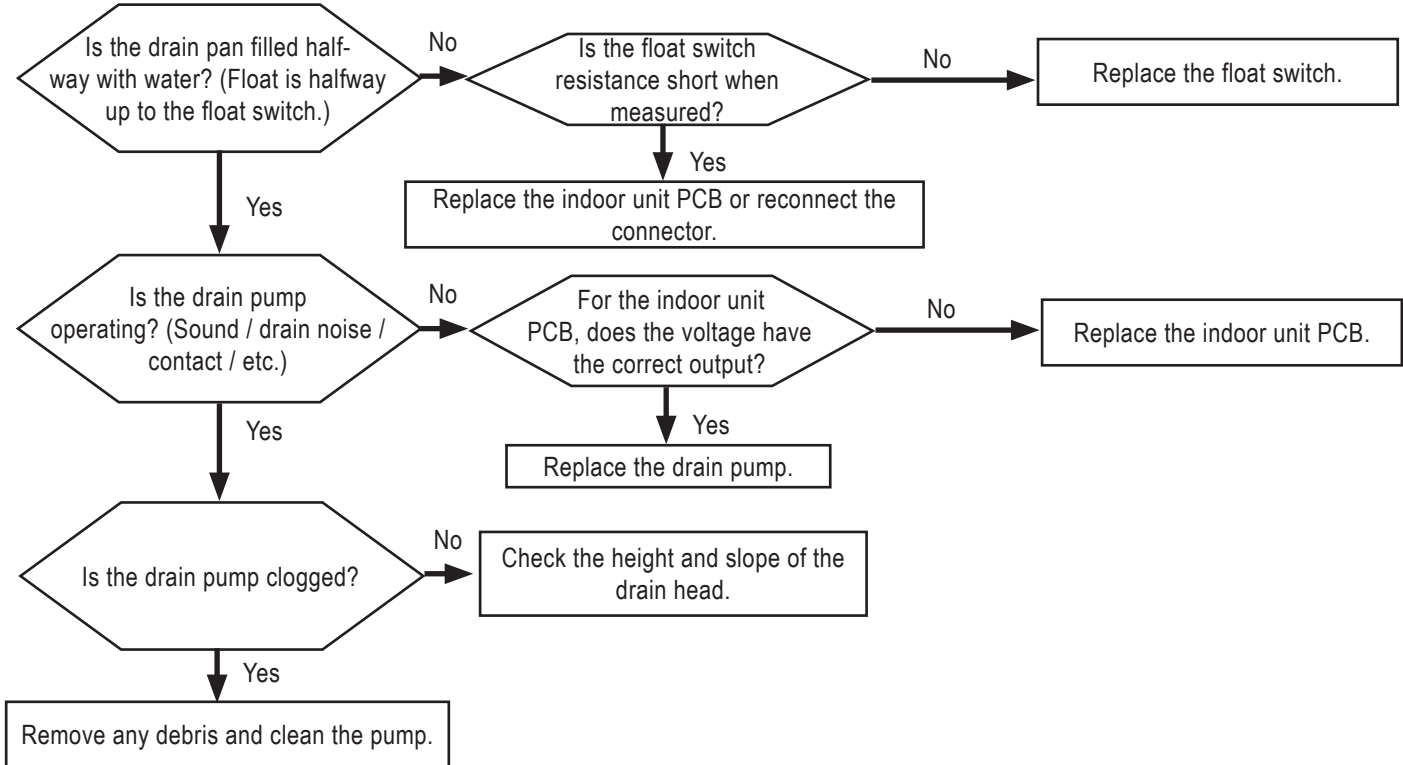

MULTI V S Outdoor Unit Service Manual

* If the float rises higher than half its height, then the circuit opens and the unit automatically stops.

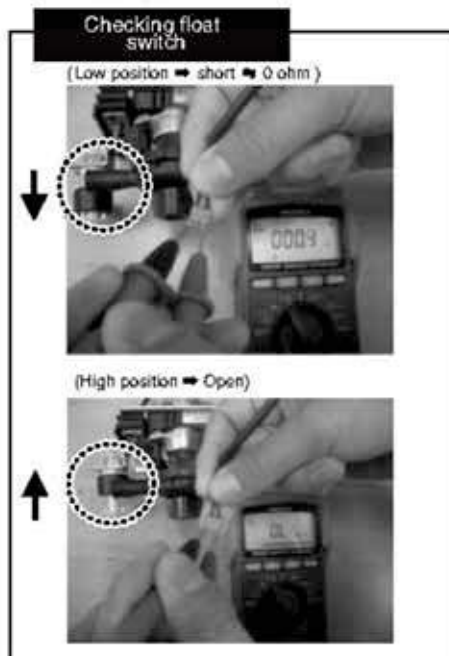
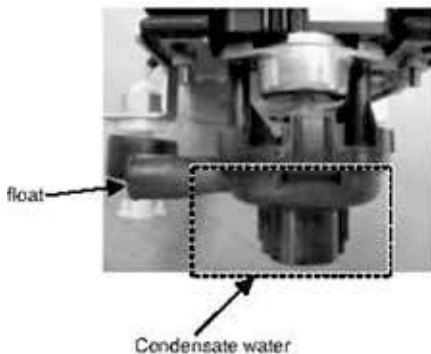

Note:
 Images here are representative of system components. Actual component appearance depends on model and system type.

⚠ WARNING Please refer to the Safety Precautions on pages 4-7 for more detail to prevent injury or death regarding the operation and service troubleshooting of the Multi V product.

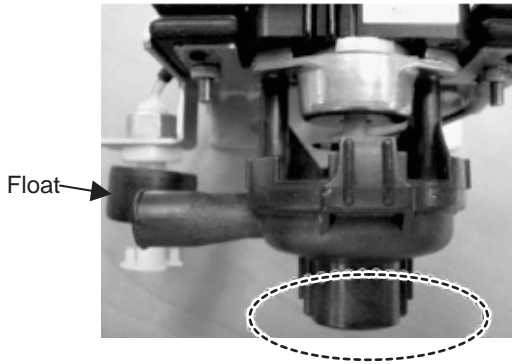

A: Point to Check Rotation



** Indoor PCB Drain Pump Connector
(Check Electrical Input; Marked as CN-DPUMP)

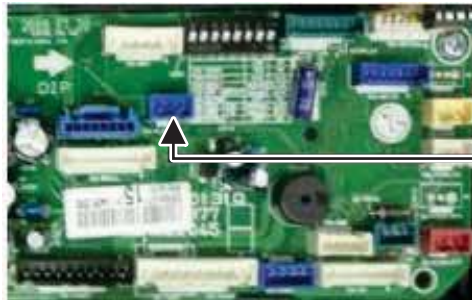

Float Switch Housing (CN-FLOAT)

Note:

Images here are representative of system components. Actual component appearance depends on model and system type.

Standard Drain Pipe Height / Slope.

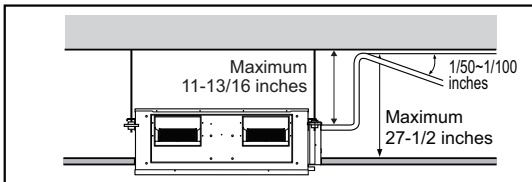

ERROR CODES

Error No. 05

⚠ WARNING Please refer to the Safety Precautions on pages 4-7 for more detail to prevent injury or death regarding the operation and service troubleshooting of the Multi V product.

Error No.	Description	Details	Causes
05	Communication error between outdoor unit PCB and indoor unit PCB.	Indoor unit PCB is not receiving communications signal from outdoor unit PCB for more than 5 minutes. Check indoor unit PCB for issues.	<ol style="list-style-type: none"> 1. Auto addressing has not been performed properly. 2. Communication cable is not connected. 3. Communication cable is short circuiting. 4. Indoor unit communication circuit error. 5. Outdoor unit communication circuit error. 6. Not enough physical distance between power wiring and communication cables. 7. T-phase line disconnection.

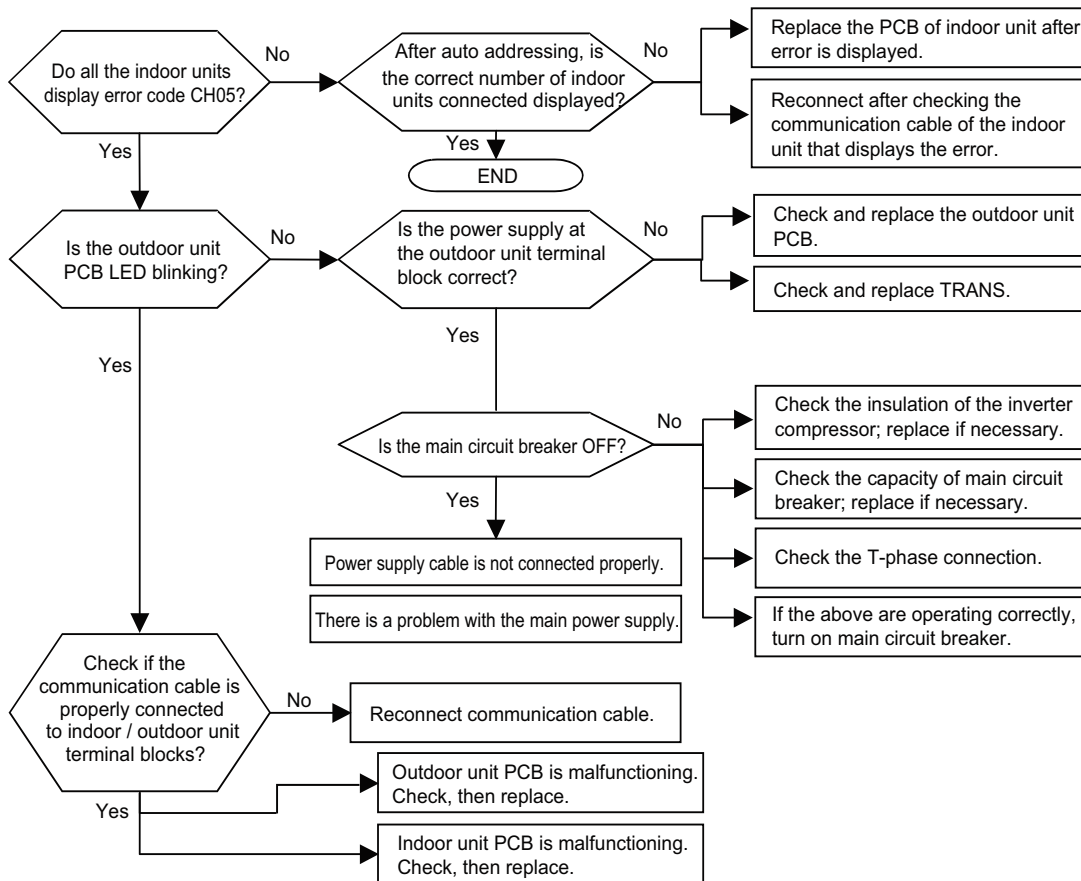

Note:

Images here are representative of system components. Actual component appearance depends on model and system type.

Communication from the indoor unit is normal if voltage fluctuation (-9V ~ +9V) exists (when checking DC voltage of the communication terminal between the indoor and outdoor units).

If the DC voltage between communication terminal A, B of indoor unit fluctuates within -9V ~ +9V, then the communication from the outdoor unit is normal.

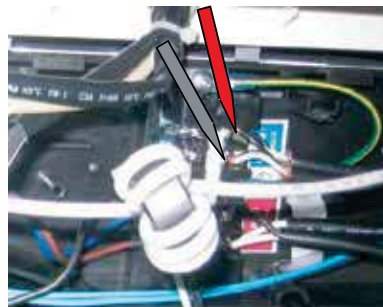

Note:

See also Error Code No. 237: RS-485 Communication Error Between Indoor Unit and Outdoor Unit, and Error Code No. 238: Outdoor Unit PCB Communication Error Between Indoor Unit and Outdoor Unit.

⚠ WARNING *Please refer to the Safety Precautions on pages 4-7 for more detail to prevent injury or death regarding the operation and service troubleshooting of the Multi V product.*

Error No.	Description	Details	Causes
09	Indoor unit EEPROM error.	<ul style="list-style-type: none"> • Serial number on EEPROM of indoor unit is 0 or FFFFFFFF. • Communication error between MICOM and EEPROM. • Indoor unit PCB EEPROM is in error or data is not available. 	<ol style="list-style-type: none"> 1. Error developed in transmission between the microprocessor and the EEPROM on the indoor unit PCB. 2. EEPROM is damaged.

Replace the indoor unit PCB, perform the Auto Addressing procedure, and input the central control address.

ERROR CODES

Error No. 10

⚠ WARNING Please refer to the Safety Precautions on pages 4-7 for more detail to prevent injury or death regarding the operation and service troubleshooting of the Multi V product.

Error No.	Description	Details	Causes
10	Indoor unit BLDC fan motor communications error.	Indoor BLDC fan motor feedback signal has been absent for at least 50 seconds.	<ol style="list-style-type: none"> 1. Fan motor connector has disconnected, removed, or malfunctioned. 2. Indoor fan motor lock has failed. 3. Indoor PCB error.

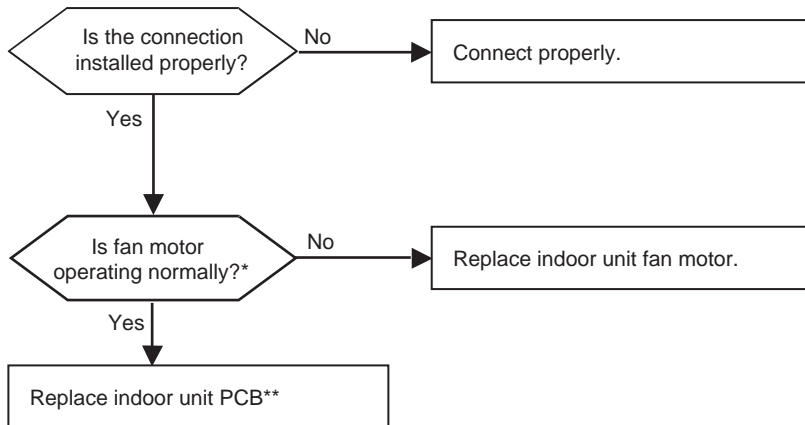

*The indoor unit fan motor hall sensor is operating normally when the values measured are as shown below.

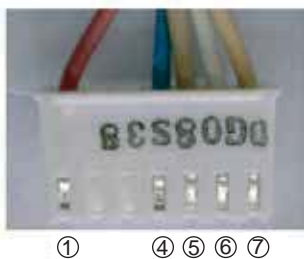

Measure Each Terminal with the Tester

Tester		Normal Resistance (±10%)	
+	-		
①	④	∞	∞
⑤	④	Hundreds kΩ	Hundreds kΩ
⑥	④	∞	∞
⑦	④	Hundreds kΩ	Hundreds kΩ

Checking the Fan Motor Connections



Note:

Images here are representative of system components. Actual component appearance depends on model and system type.

** Replace the indoor unit PCB, perform the Auto Addressing procedure, and then input the central control address.

⚠ WARNING

Check the fan motor connection to the PCB only when power is OFF. Electrical shock can cause physical injury or death.

WARNING Please refer to the Safety Precautions on pages 4-7 for more detail to prevent injury or death regarding the operation and service troubleshooting of the Multi V product.

Error No.	Description	Details	Causes
21	Outdoor unit inverter board IPM fault error.	<ul style="list-style-type: none"> IPM has overheated, or has been subjected to overcurrent or undercurrent conditions. IPM protection circuit has been activated. Inverter driver detects overcurrent; Error code is determined by overcurrent in any one phase of compressor 	<ol style="list-style-type: none"> Overcurrent conditions have been detected at the inverter compressor (U,V,W). Compressor motor or insulation has been damaged. IPM has overheated due to damage or disconnection of the heat sink fan, or the heat sink has been disassembled. Inverter compressor terminal has been disconnected or loosened. Inverter PCB assembly has been damaged. Low input current to the outdoor unit. Damaged inverter board – input voltage too low. For 208-230V: On 068 compressors = 143A for a minimum of 3μs; on 048 compressors = 96A for a minimum of 3μs.

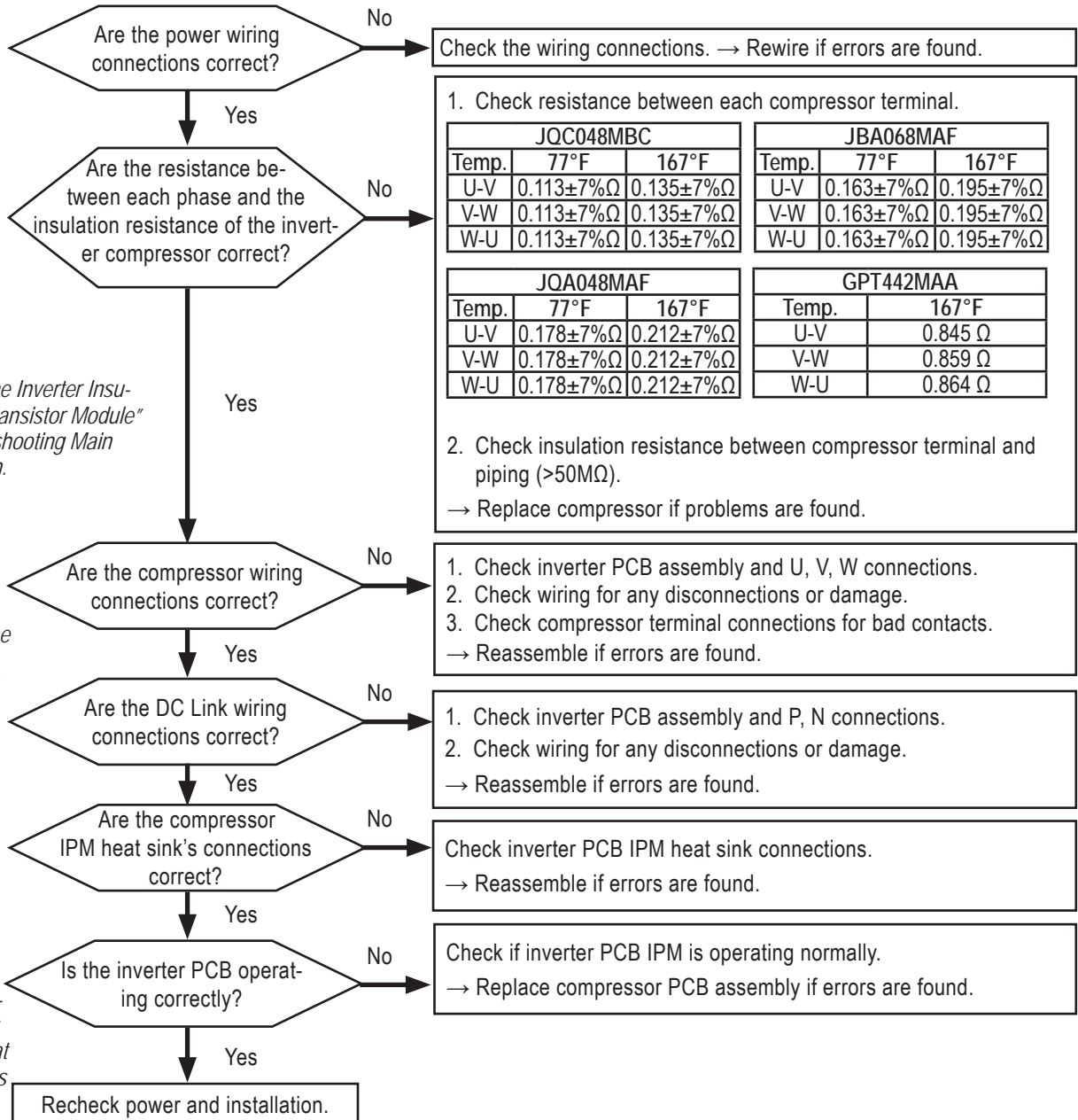

Note:

See the "Checking the Inverter Insulated-Gate Bipolar Transistor Module" page in the "Troubleshooting Main Components" section.

Note:

See the "Checking the Inverter Compressor Phase Diode Bridge" page later in this section.

Note:

Always apply heat transfer paste to the new inverter PCB heat sink before installing. For instructions, see "Replacing the Inverter PCB Heat sink" page later in this section.

ERROR CODES

Error No. 21, continued.

⚠ WARNING Please refer to the Safety Precautions on pages 4-7 for more detail to prevent injury or death regarding the operation and service troubleshooting of the Multi V product.

Figure 43: ARUN024 to 053GSS4 Error No. 21 Compressor Terminal and Wiring Connections.

Measuring the resistance between compressor terminal.



Compressor wiring connections.

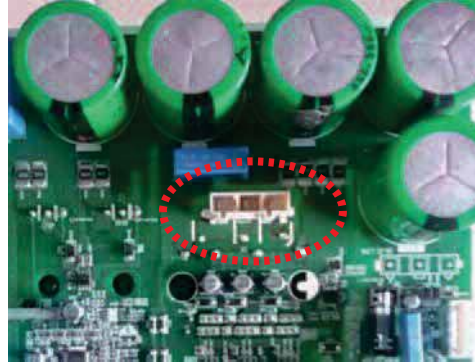

Figure 44: ARUN060GSS4 and ARUB060GSS4 Error No. 21 Compressor Terminal and Wiring Connections.

Measuring the resistance between compressor terminals.



Compressor wiring connections.



Note:

Images here are representative of system components. Actual component appearance depends on model and system type.

⚠ WARNING Please refer to the Safety Precautions on pages 4-7 for more detail to prevent injury or death regarding the operation and service troubleshooting of the Multi V product.

Error No.	Description	Details	Causes
22	Outdoor unit AC inverter board input overcurrent (RMS) error.	The input power current for the inverter PCB assembly is >30A (ARUN024 ~53GSS4) or >38A (ARUN060GSS4 and ARUB060GSS4).	<ol style="list-style-type: none"> 1. Overload: Pipe has been clogged, EEV is defective, indoor or outdoor unit is blocked, there has been an overcharge in refrigerant. 2. Compressor motor or insulation has been damaged. 3. Input voltage is low. 4. Improper connections in the power wiring. 5. Inverter PCB assembly has been damaged (input current sensor).

Note:

See the "Checking the Inverter Insulated-Gate Bipolar Transistor Module" page in the "Troubleshooting Main Components" section.

Note:

See the "Checking the Inverter Compressor Phase Diode Bridge" page later in this section.

Note:

Always apply heat transfer paste to the new inverter PCB heat sink before installing. For instructions, see "Replacing the Inverter PCB Heat Sink" page later in this section.

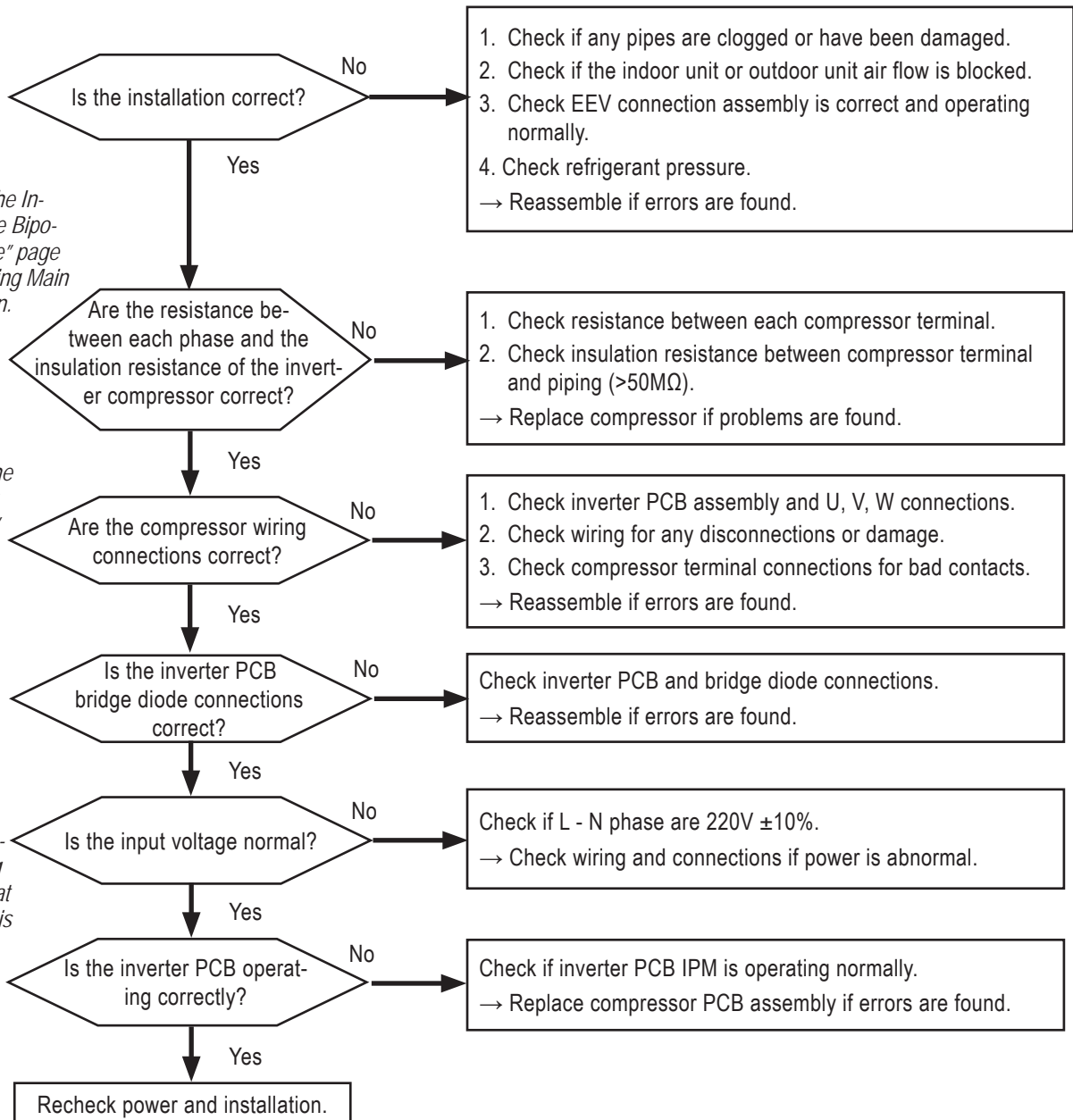

ERROR CODES

Error No. 22, continued.

⚠ WARNING Please refer to the Safety Precautions on pages 4-7 for more detail to prevent injury or death regarding the operation and service troubleshooting of the Multi V product.

Figure 45: ARUN024 to 053GSS4 Error No. 22 Compressor Terminal and Wiring Connections.

Measure resistance between each compressor terminal.



Measure input voltage.



Note:

Images here are representative of system components. Actual component appearance depends on model and system type.

Compressor wiring connections.



Figure 46: ARUN060GSS4 and ARUB060GSS4 Error No. 22 Compressor Terminal and Wiring Connections.

Measure resistance between each compressor terminal.



Measure input voltage.



Compressor wiring connections.



⚠ WARNING Please refer to the Safety Precautions on pages 4-7 for more detail to prevent injury or death regarding the operation and service troubleshooting of the Multi V product.

Error No.	Description	Details	Causes
23	Low or high DC voltage sensed at the outdoor unit inverter compressor DC link.	System shut off because DC voltage has not charged, or because of an overcurrent in the outdoor unit inverter PCB DC link voltage.	<ol style="list-style-type: none"> 1. DC link terminal disconnection or terminal contact fault. 2. System shut off because outdoor unit inverter compressor DC link voltage fell below 50V, or exceeded 550V for a minimum of 250μs. 3. Condenser is damaged. 4. Inverter PCB assembly is damaged (DC Link voltage sensor). 5. Improper input voltage or power wiring.

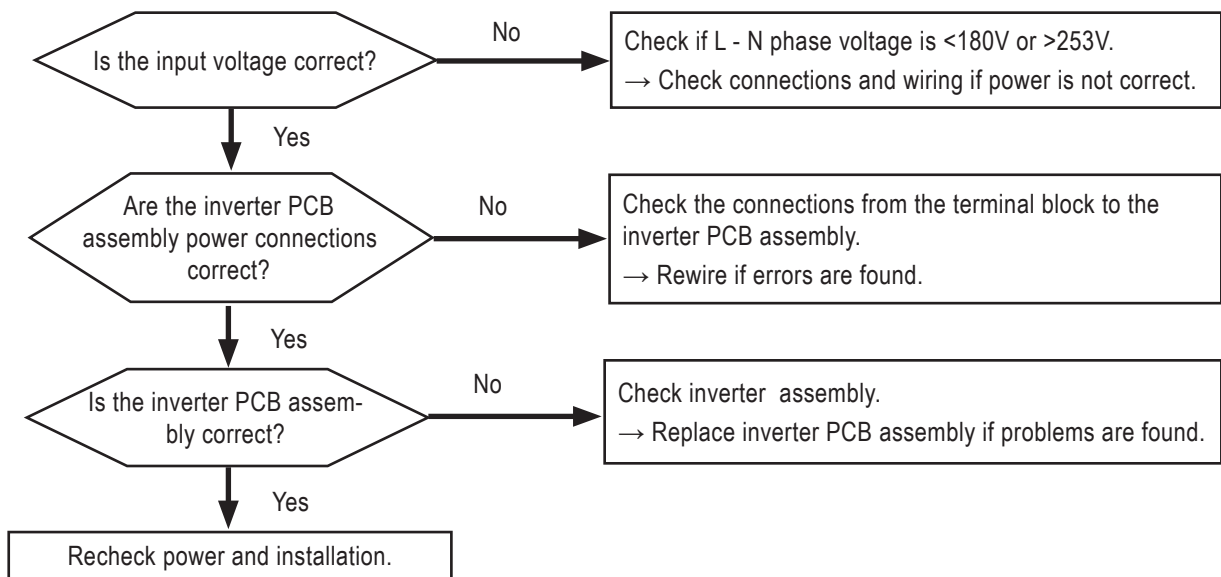

Note:

See the "Checking the Inverter Insulated-Gate Bipolar Transistor Module" and the "Checking the Phase Diode Bridge" pages in the "Troubleshooting Main Components" section.

Note:

Always apply heat transfer paste to the new inverter PCB heat sink before installing. For instructions, see "Replacing the Inverter PCB Heat sink" page later in this section.

ERROR CODES

Error No. 24

WARNING Please refer to the Safety Precautions on pages 4-7 for more detail to prevent injury or death regarding the operation and service troubleshooting of the Multi V product.

Error No.	Description	Details	Causes
24	System has been turned off by the outdoor unit high pressure switch.	Outdoor unit high pressure switch error. Excessive increase in outdoor unit compressor discharge pressure.	<ol style="list-style-type: none"> Outdoor unit high pressure switch is defective. Indoor unit fan or outdoor unit fan is / are defective. Compressor check valve is clogged. Pipe has been damaged. Overcharge of refrigerant. Defective EEV at the indoor or outdoor unit. Outdoor unit is blocked during cooling mode; indoor unit filter is clogged during heating mode. Service valve is clogged. Outdoor unit PCB is defective. Check connection on the outdoor unit PCB. Active path valve is defective. Use chart in Troubleshooting section of the manual to check signal output (V DC) versus actual pressure.

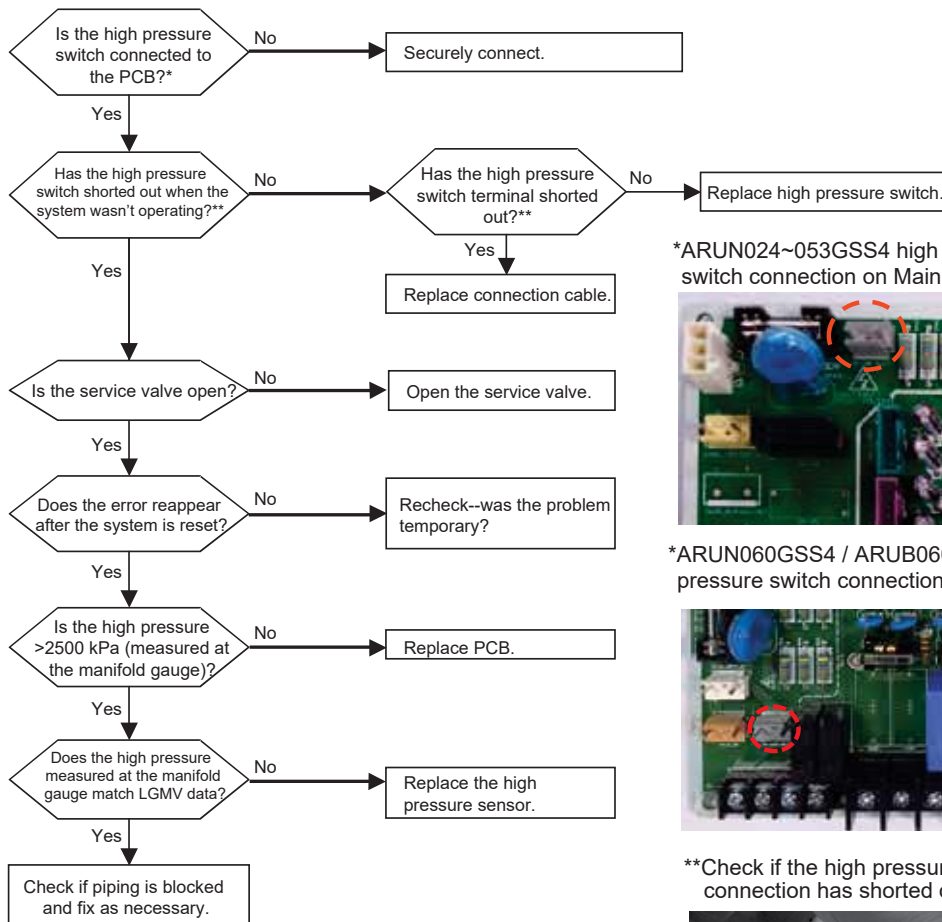

*ARUN024~053GSS4 high pressure switch connection on Main PCB.



*ARUN060GSS4 / ARUB060GSS4 high pressure switch connection on Main PCB.

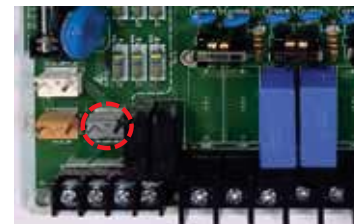

**Check if the high pressure switch connection has shorted out.

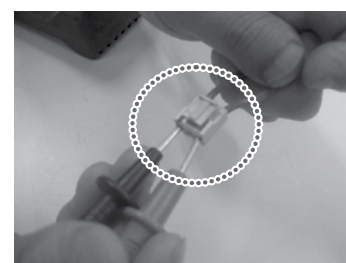

Note:

Images here are representative of system components. Actual component appearance depends on model and system type.

⚠ WARNING Please refer to the Safety Precautions on pages 4-7 for more detail to prevent injury or death regarding the operation and service troubleshooting of the Multi V product.

Error No.	Description	Details	Causes
25	Input voltage to the outdoor unit is too high or too low.	Outdoor unit has an input voltage of <140V or >300V.	<ol style="list-style-type: none"> 1. Input voltage is abnormal. 2. Outdoor unit inverter PCB assembly is damaged (input voltage sensor component). 3. A phase line is disconnected.

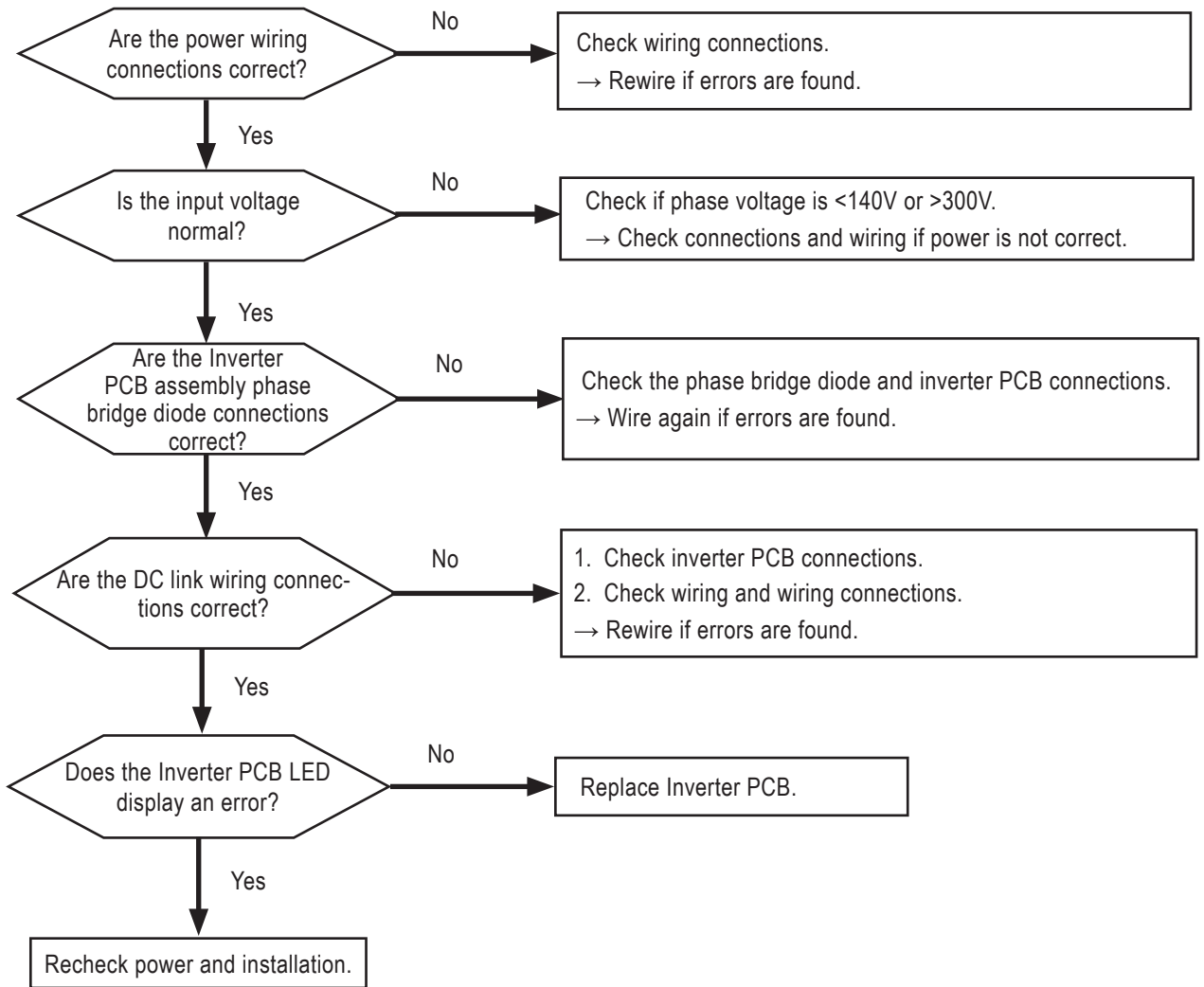

Error Codes

ERROR CODES

Error No. 26

WARNING Please refer to the Safety Precautions on pages 4-7 for more detail to prevent injury or death regarding the operation and service troubleshooting of the Multi V product.

Error No.	Description	Details	Causes
26	Outdoor unit inverter compressor operation error.	Inverter compressor start failure.	<ol style="list-style-type: none"> 1. Overload error: Piping is clogged, indoor or outdoor unit is blocked, EEV is defective, or there is an overcharge in refrigerant. 2. Compressor insulation and / or motor has been damaged. 3. Compressor wiring error. 4. Outdoor unit inverter PCB has been damaged (CT).

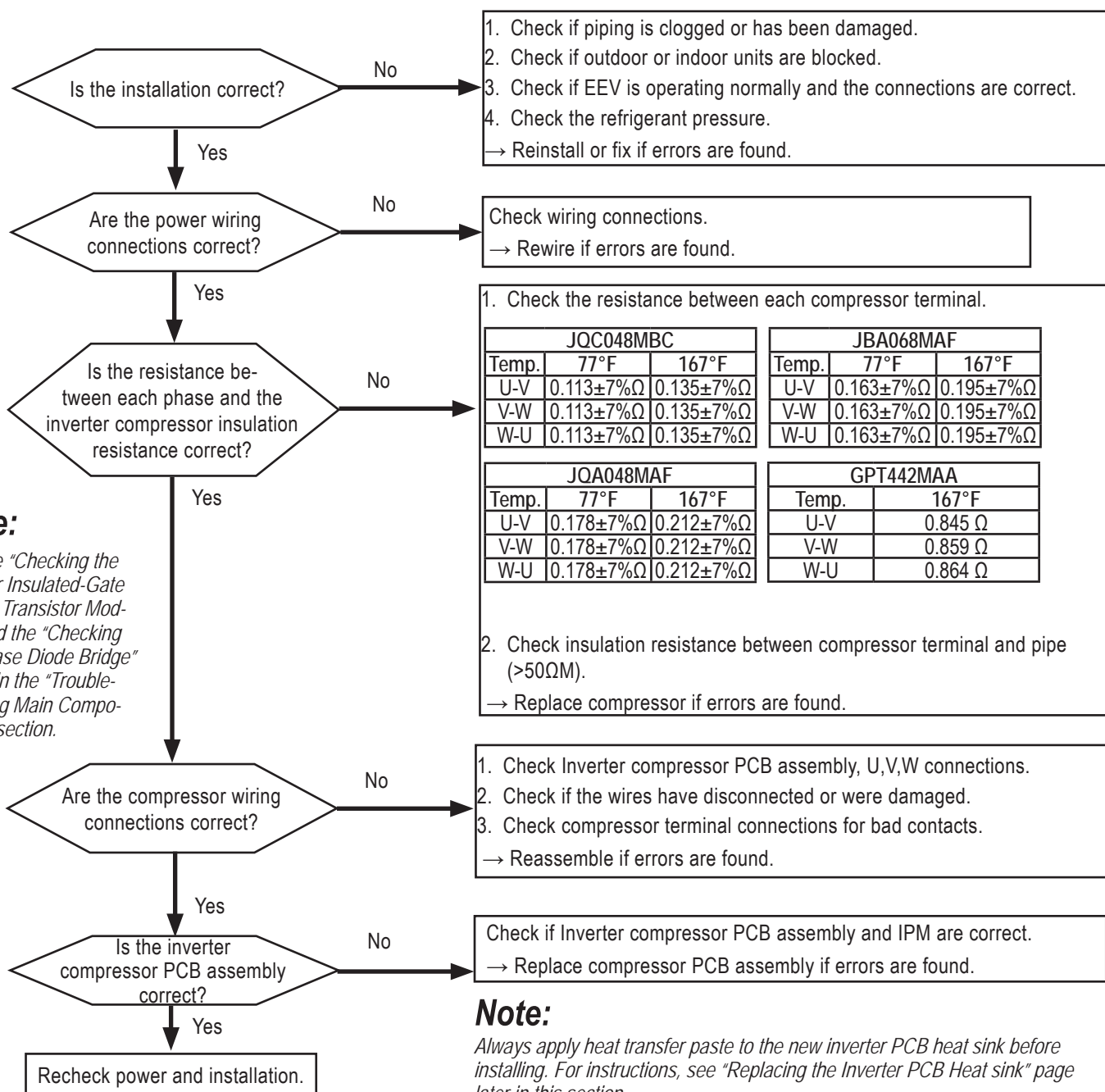

1. Check if piping is clogged or has been damaged.
 2. Check if outdoor or indoor units are blocked.
 3. Check if EEV is operating normally and the connections are correct.
 4. Check the refrigerant pressure.
 → Reinstall or fix if errors are found.

Check wiring connections.
 → Rewire if errors are found.

1. Check the resistance between each compressor terminal.

JQC048MBC			JBA068MAF		
Temp.	77°F	167°F	Temp.	77°F	167°F
U-V	0.113±7%Ω	0.135±7%Ω	U-V	0.163±7%Ω	0.195±7%Ω
V-W	0.113±7%Ω	0.135±7%Ω	V-W	0.163±7%Ω	0.195±7%Ω
W-U	0.113±7%Ω	0.135±7%Ω	W-U	0.163±7%Ω	0.195±7%Ω

JQA048MAF			GPT442MAA	
Temp.	77°F	167°F	Temp.	167°F
U-V	0.178±7%Ω	0.212±7%Ω	U-V	0.845 Ω
V-W	0.178±7%Ω	0.212±7%Ω	V-W	0.859 Ω
W-U	0.178±7%Ω	0.212±7%Ω	W-U	0.864 Ω

2. Check insulation resistance between compressor terminal and pipe (>50ΩM).
 → Replace compressor if errors are found.

1. Check Inverter compressor PCB assembly, U,V,W connections.
 2. Check if the wires have disconnected or were damaged.
 3. Check compressor terminal connections for bad contacts.
 → Reassemble if errors are found.

Check if Inverter compressor PCB assembly and IPM are correct.
 → Replace compressor PCB assembly if errors are found.

Recheck power and installation.

⚠ WARNING Please refer to the Safety Precautions on pages 4-7 for more detail to prevent injury or death regarding the operation and service troubleshooting of the Multi V product.

Figure 47: ARUN024 to 053GSS4 Error No. 22 Compressor Terminal and Wiring Connections.

Measure resistance between each compressor terminal.



Note:

Images here are representative of system components. Actual component appearance depends on model and system type.

Compressor wiring connections.

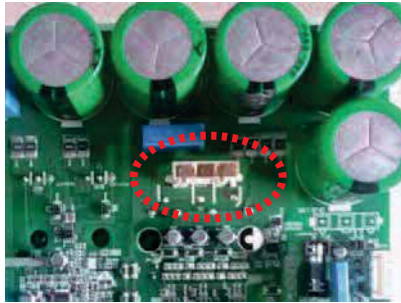

Figure 48: ARUN060GSS4 and ARUB060GSS4 Error No. 22 Compressor Terminal and Wiring Connections.

Measuring the resistance between compressor terminals.



Compressor wiring connections.



ERROR CODES

Error No. 29

⚠ WARNING Please refer to the Safety Precautions on pages 4-7 for more detail to prevent injury or death regarding the operation and service troubleshooting of the Multi V product.

Error No.	Description	Details	Causes
29	Outdoor unit inverter compressor overcurrent error.	Inverter compressor input current is >30A.	<ol style="list-style-type: none"> 1. Overload operation (piping is clogged, indoor or outdoor unit is blocked, EEV is defective, refrigerant is overcharged). 2. Compressor insulation and / or motor is / are damaged. 3. Input voltage is low. 4. Outdoor unit Inverter PCB assembly is damaged.

Note:

See the "Checking the Inverter Insulated-Gate Bipolar Transistor Module" page in the "Troubleshooting Main Components" section.

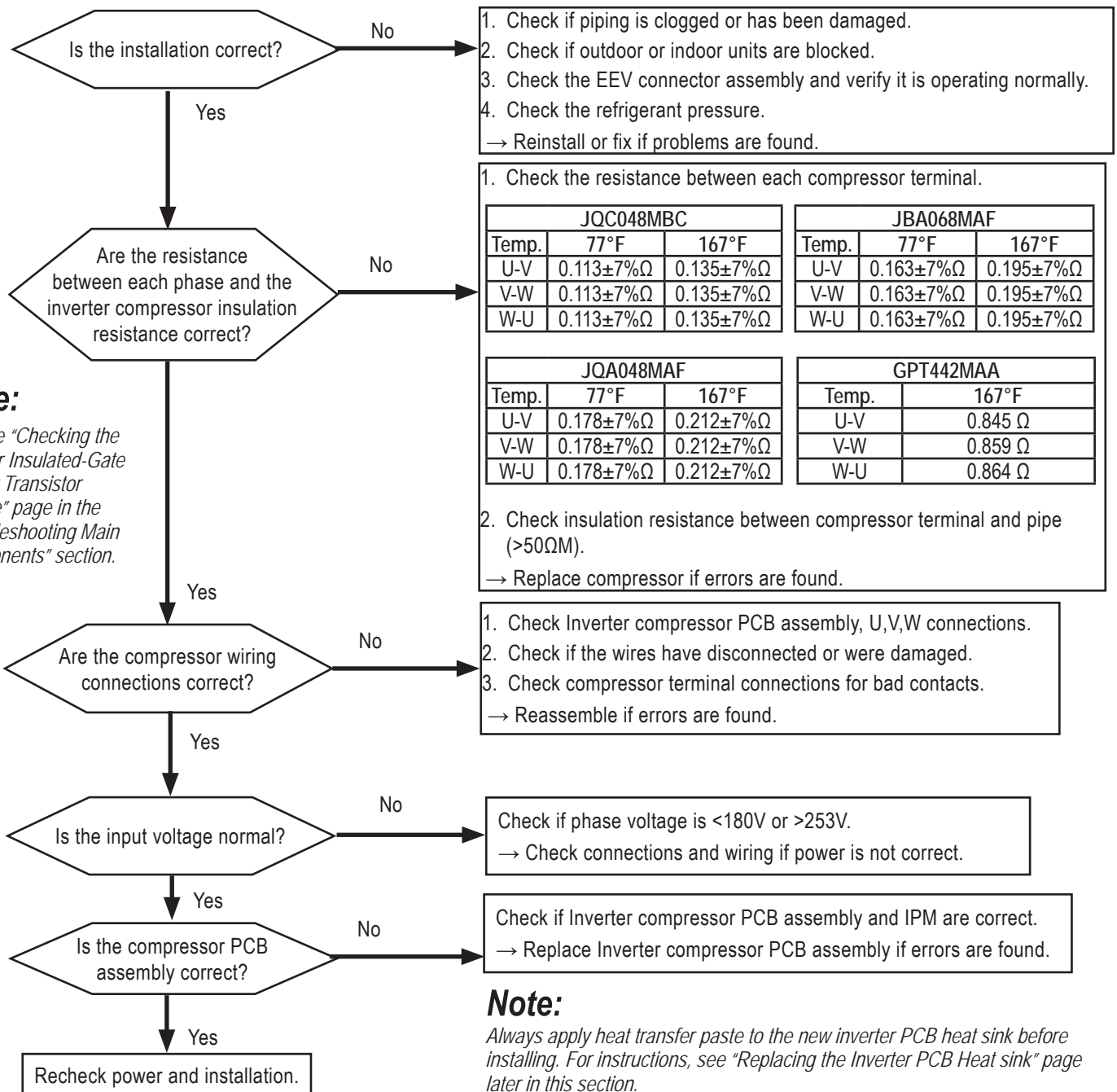

Note:

Always apply heat transfer paste to the new inverter PCB heat sink before installing. For instructions, see "Replacing the Inverter PCB Heat sink" page later in this section.

⚠ WARNING Please refer to the Safety Precautions on pages 4-7 for more detail to prevent injury or death regarding the operation and service troubleshooting of the Multi V product.

Figure 49: ARUN024 to 053GSS4 Error No. 29 Compressor Terminal and Wiring Connections.

Measure resistance between each compressor terminal.



Measure input voltage.



Note:

Images here are representative of system components. Actual component appearance depends on model and system type.

Compressor wiring connections.



Figure 50: ARUN060GSS4 and ARUB060GSS4 Error No. 29 Compressor Terminal and Wiring Connections.

Measure resistance between each compressor terminal.



Measure input voltage.



Compressor wiring connections.



ERROR CODES

Error No. 32

⚠ WARNING Please refer to the Safety Precautions on pages 4-7 for more detail to prevent injury or death regarding the operation and service troubleshooting of the Multi V product.

Error No.	Description	Details	Causes
32	Excessive increase in the discharge temperature at the outdoor unit inverter compressor.	System / compressor shut off because of a high discharge temperature at the outdoor unit inverter compressor.	<ol style="list-style-type: none"> 1. System shutdown happens when discharge pipe temperature rises $>115^{\circ}\text{C}$ (239°F) for 10 seconds, or compressor temperature equals 105°C (221°F) for 10 seconds. 2. Defective compressor discharge piping temperature sensor. 3. Refrigerant is leaking or there is under-charge. 4. Defective EEV. 5. Defective liquid spray valve.

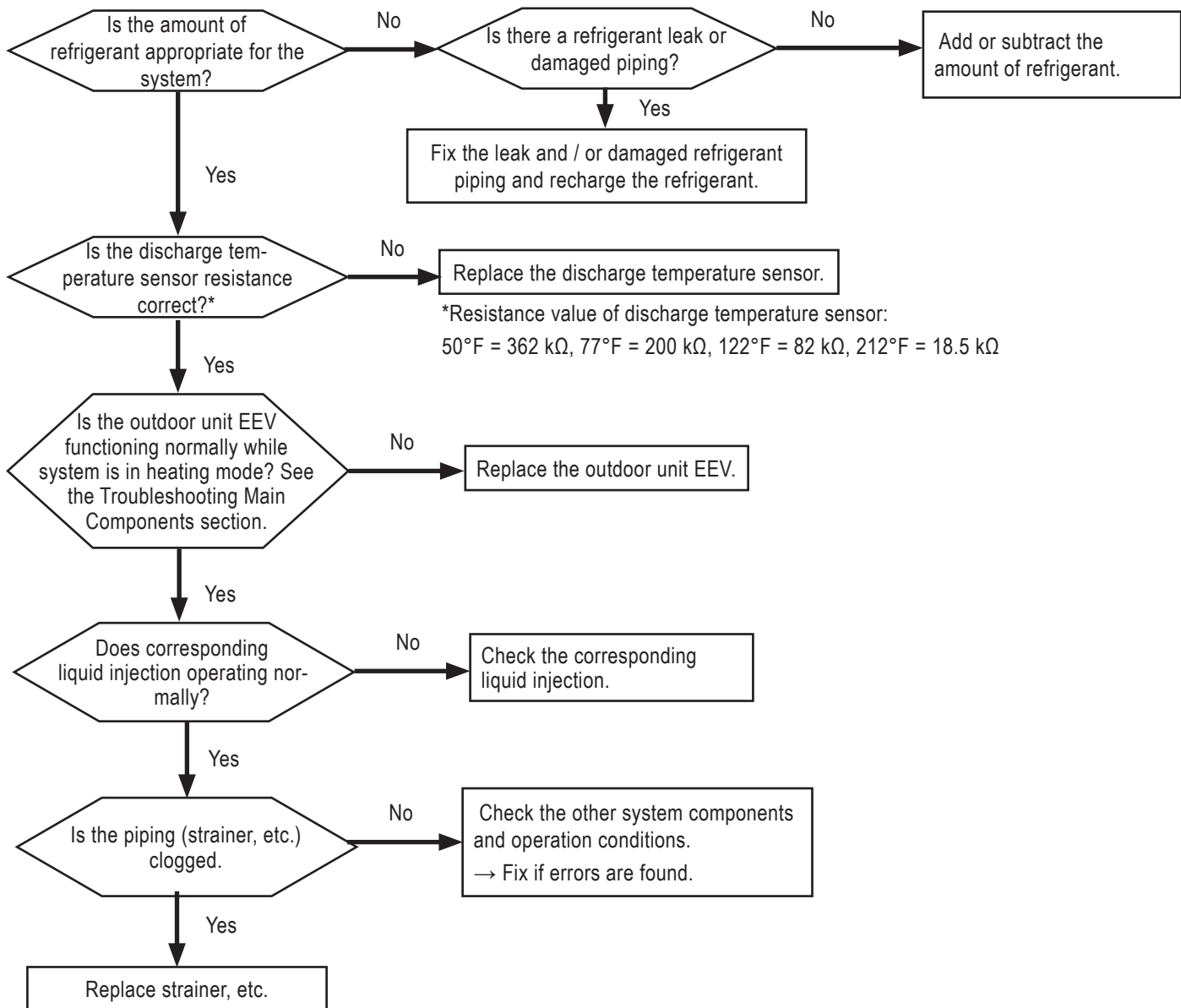

⚠ WARNING Please refer to the Safety Precautions on pages 4-7 for more detail to prevent injury or death regarding the operation and service troubleshooting of the Multi V product.

Error No.	Description	Details	Causes
34	Outdoor unit compressor high pressure safety tripped.	System shut off because of an excessive increase in pressure at the outdoor unit that occurred ten (10) consecutive times.	<ol style="list-style-type: none"> 1. Shutdown due to if compressor high pressure is >4,000 kPa (580 psi) for ten (10) seconds. 2. Defective high pressure sensor. 3. Defective indoor unit and / or outdoor unit fan. 4. Refrigerant is overcharged. 5. Refrigerant pipe is damaged. 6. Defective indoor and / or outdoor unit EEV. 7. Outdoor unit is blocked during cooling, or indoor unit filter is blocked during heating. 8. Service valve is clogged. 9. Defective outdoor unit PCB. 10. Defective indoor unit pipe temperature. 11. Defective indoor unit pipe temperature sensor. 12. Defective hot gas valve.

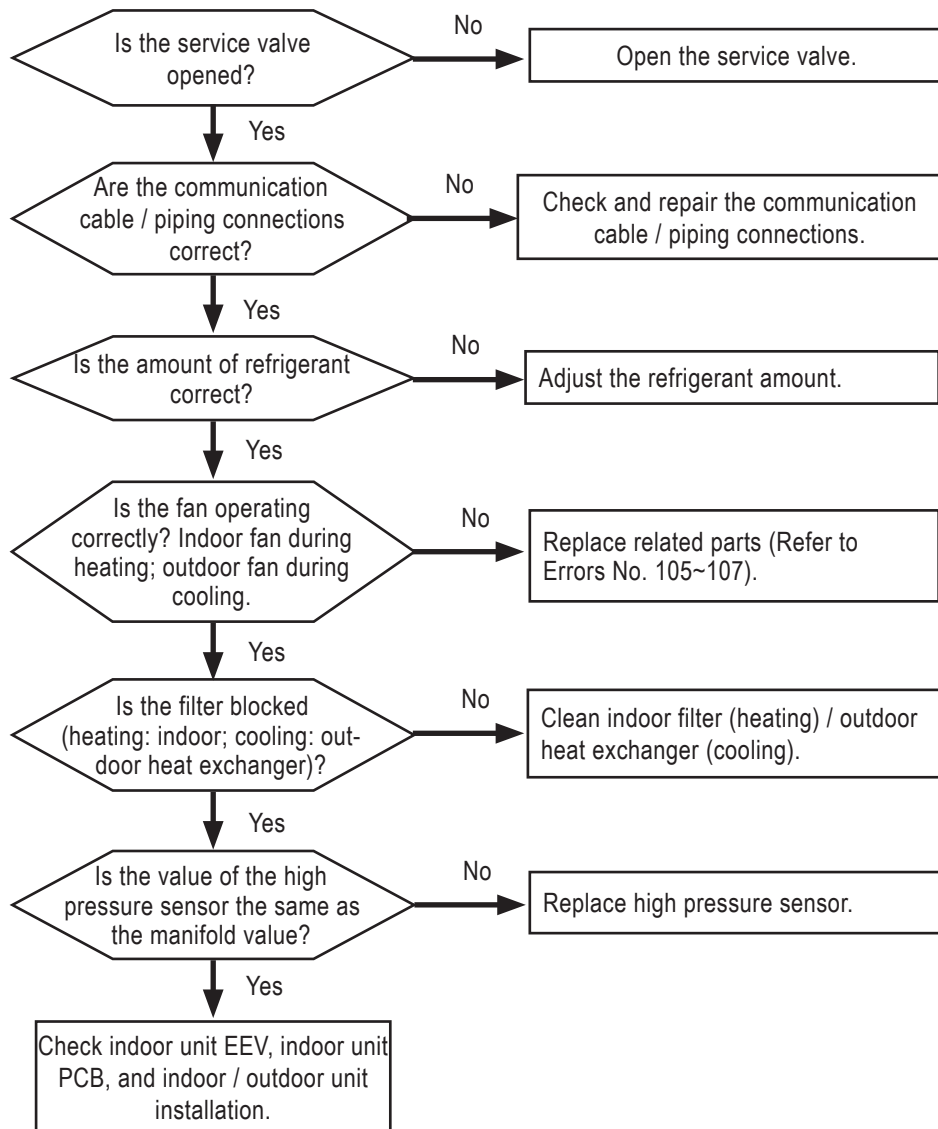

Error Codes

ERROR CODES

Error No. 35

⚠ WARNING Please refer to the Safety Precautions on pages 4-7 for more detail to prevent injury or death regarding the operation and service troubleshooting of the Multi V product.

Error No.	Description	Details	Causes
35	Outdoor unit low side pressure transducer senses pressure below allowable limits.	System shut off because of an excessive decrease in pressure at the outdoor unit that occurred three (3) consecutive times.	<ol style="list-style-type: none"> 1. Defective low pressure sensor. 2. Defective indoor unit or outdoor unit fan. 3. Refrigerant amount is undercharged or overcharged. 4. Refrigerant piping is damaged. 5. Defective indoor / outdoor unit EEV. 6. The outdoor unit is blocked (dirty coil) in heating, and/or the indoor unit filter is blocked (plugged) in cooling. 7. Service valve is clogged. 8. Defective outdoor unit PCB. 9. Defective indoor unit pipe temperature sensor.

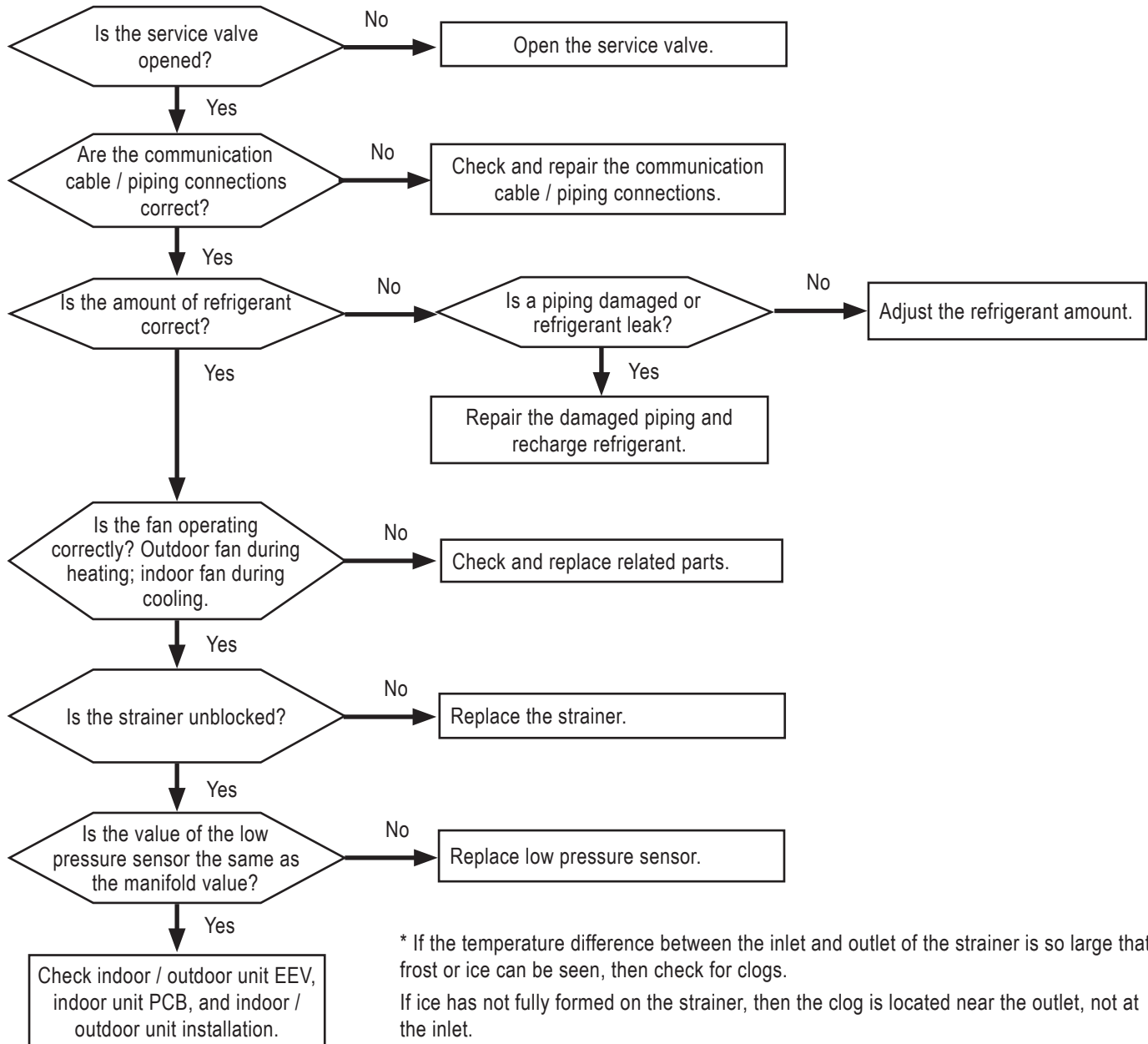

⚠ WARNING Please refer to the Safety Precautions on pages 4-7 for more detail to prevent injury or death regarding the operation and service troubleshooting of the Multi V product.

Error No.	Description	Details	Causes
36	Outdoor unit inverter low compression ratio.	Outdoor unit is experiencing a problem developing compressor lift. Error is calling out low compression ratio. System will shut down and display error code "CH36".	<ol style="list-style-type: none"> 1. Error occurs if the compression ratio is <1.6 (scroll compressor) or <1.8 (rotary compressor) for 2 minutes following a change in position of the reversing valve (either direction), and for 5 minutes following a compressor start. 2. Pressure differential: <400kPa (scroll compressor), and 500kPa (rotary compressor). 3. Check bypass between high and low pressure side: EEV fully open, poor reversing valve operation, direct connection between low and high pressure vapor pipe (especially if reverse connection at Y-branch).

ERROR CODES

Error No. 40

⚠ WARNING Please refer to the Safety Precautions on pages 4-7 for more detail to prevent injury or death regarding the operation and service troubleshooting of the Multi V product.

Error No.	Description	Details	Causes
40	Outdoor unit inverter compressor current transducer (CT) sensor error.	Disconnection or short circuit of outdoor unit inverter compressor current detection (CT) sensor. MICOM input voltage is not within 2.5V ±0.3V at initial power up.	1. Input voltage is not correct. 2. Outdoor unit inverter PCB is damaged (CT sensor component).

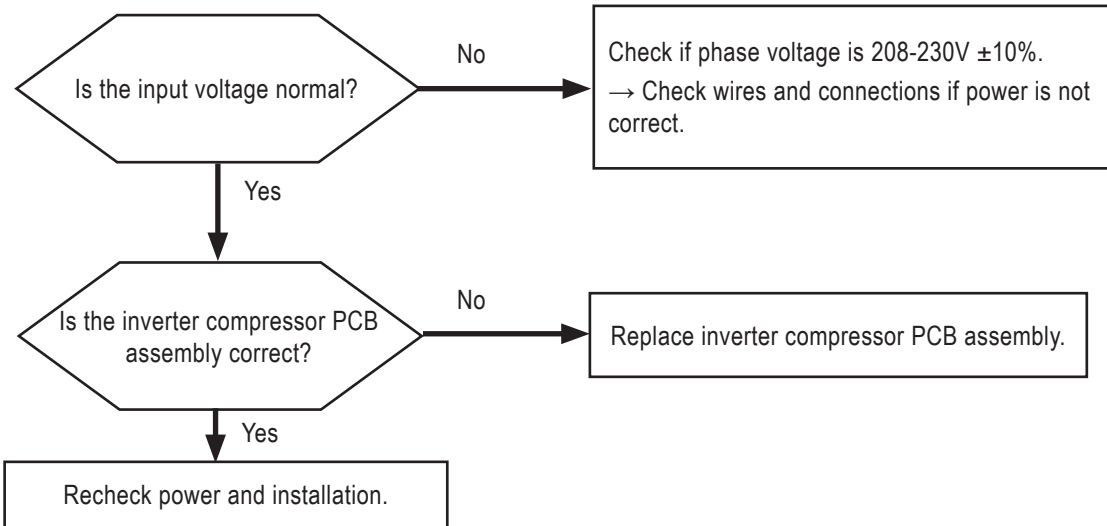

Figure 51: ARUN024 to 053GSS4 Error No. 40 Input Voltage Connections.

Measure input voltage.



Figure 52: ARUN060GSS4 and ARUB060GSS4 Error No. 40 Input Voltage Connections.

Measure input voltage.



Note:

Images here are representative of system components. Actual component appearance depends on model and system type.

WARNING Please refer to the Safety Precautions on pages 4-7 for more detail to prevent injury or death regarding the operation and service troubleshooting of the Multi V product.

Error No.	Description	Details	Causes
41	Outdoor unit inverter compressor1 discharge pipe temperature sensor error.	Disconnection or short circuit of outdoor unit compressor discharge temperature sensor.	<ol style="list-style-type: none"> 1. Error can also occur if the system is operating in cooling at extremely low temperatures with no low ambient kit. 2. Compressor discharge pipe temperature sensor (TH3) is not installed or connected properly. 3. Defective compressor discharge pipe sensor (TH3) (opened or shorted). 4. Defective outdoor unit PCB.

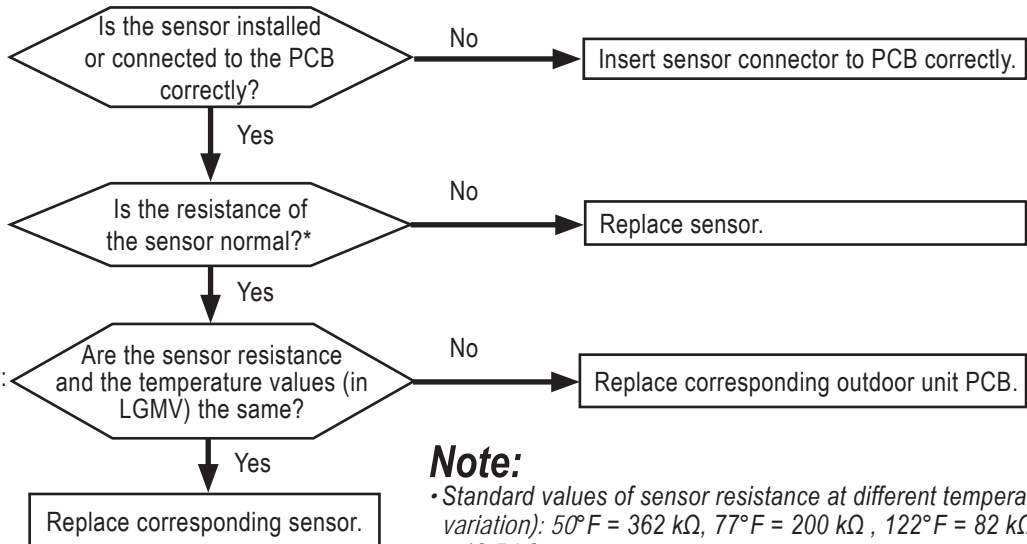

Labels for Outdoor Unit Sensors:

- Outdoor Temperature Sensor: TH1
- Pipe Temperature Sensor: TH2
- Discharge Pipe (D-pipe) Temperature Sensor: TH3

* Error is generated if resistance is >5 MΩ (open) and <2 kΩ (short).

Note:

- Standard values of sensor resistance at different temperatures (5% variation): 50°F = 362 kΩ, 77°F = 200 kΩ, 122°F = 82 kΩ, 212°F = 18.5 kΩ.
- Other temperature sensor resistance values: 77°F = 10 kΩ ± 1%; 77°F = 5 kΩ ± 1%; 77°F = 200 kΩ ± 1%; 185°F = 1.07 kΩ ± 3.3%; 185°F = 535 kΩ ± 3.3%; 185°F = 28 kΩ ± 7.7%.

Figure 53: ARUN024 to 053GSS4 Error No. 41 Checking the Inverter Compressor Discharge Temperature Sensor Resistance.

Figure 54: ARUN060GSS4 and ARUB060GSS4 Error No. 41 Checking the Inverter Compressor Discharge Temperature Sensor Resistance.

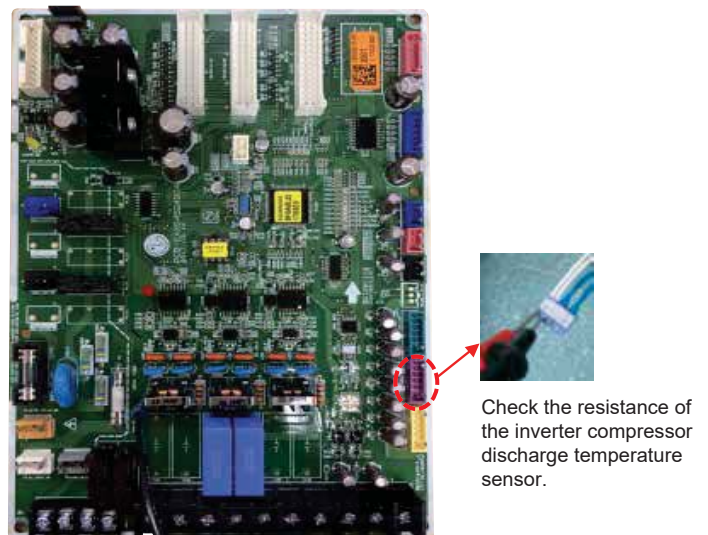
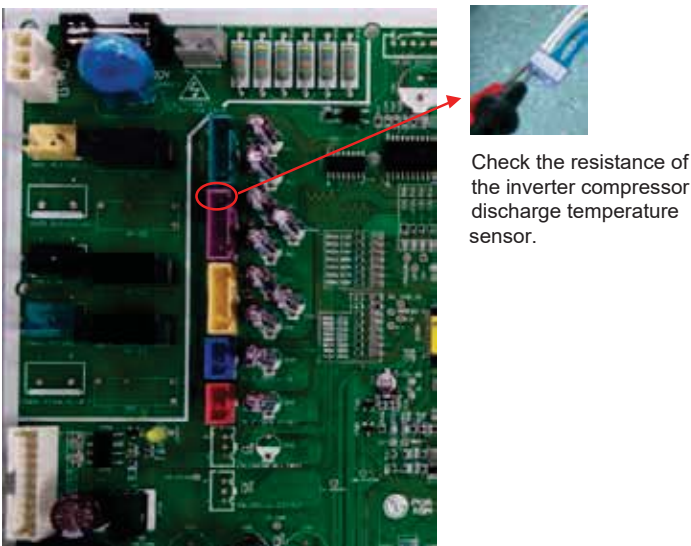

Note:

Images here are representative of system components. Actual component appearance depends on model and system type.

ERROR CODES

Error Nos. 42 and 43

⚠ WARNING Please refer to the Safety Precautions on pages 4-7 for more detail to prevent injury or death regarding the operation and service troubleshooting of the Multi V product.

Error No.	Description	Details	Causes
42	Outdoor unit low pressure sensor error.	Disconnection or short circuit of outdoor unit low pressure sensor.	1. Check the connection on the outdoor unit PCB. 2. Thermistor shorted or opened.
43	Outdoor unit high pressure sensor error.	Disconnection or short circuit of outdoor unit high pressure sensor.	3. Check for 12 V DC between 12 V and GND (red to black) for 5 V DC. 4. Check the Signal to GND (white to black) and use correct chart from Troubleshooting section to compare with actual system pressure.

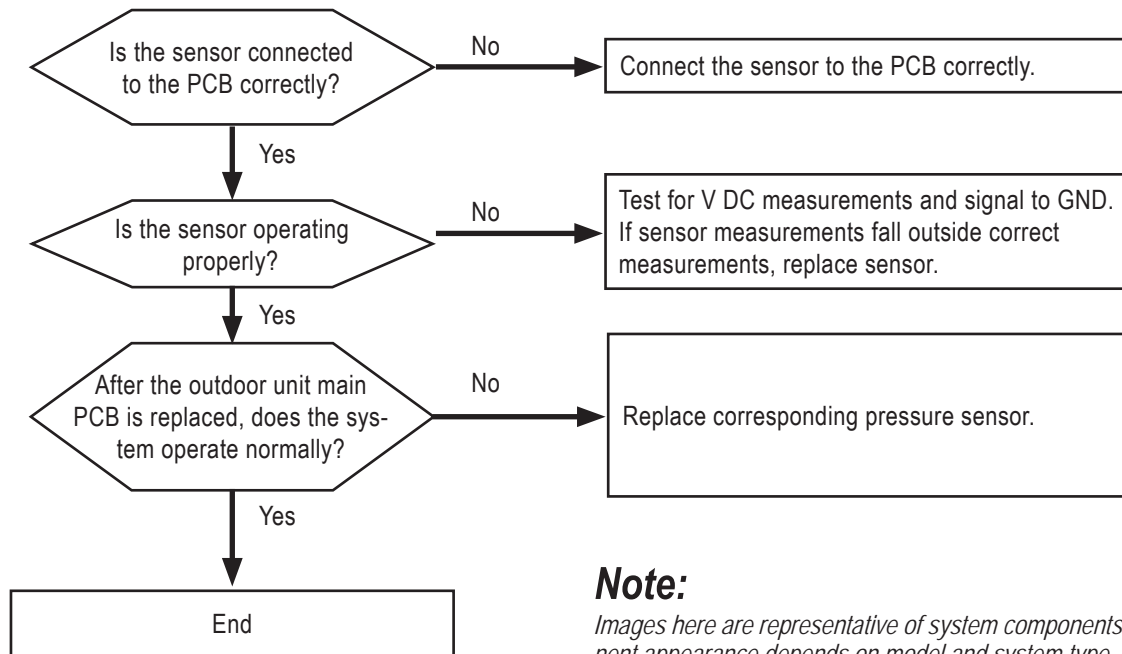

Note:

Images here are representative of system components. Actual component appearance depends on model and system type.

Figure 55: ARUN024 to 053GSS4 Error Nos. 42-43 Checking the Pressure Sensor Connections.

Figure 56: ARUN060GSS4 and ARUB060GSS4 Error Nos. 42-43 Checking the Pressure Sensor Connections.

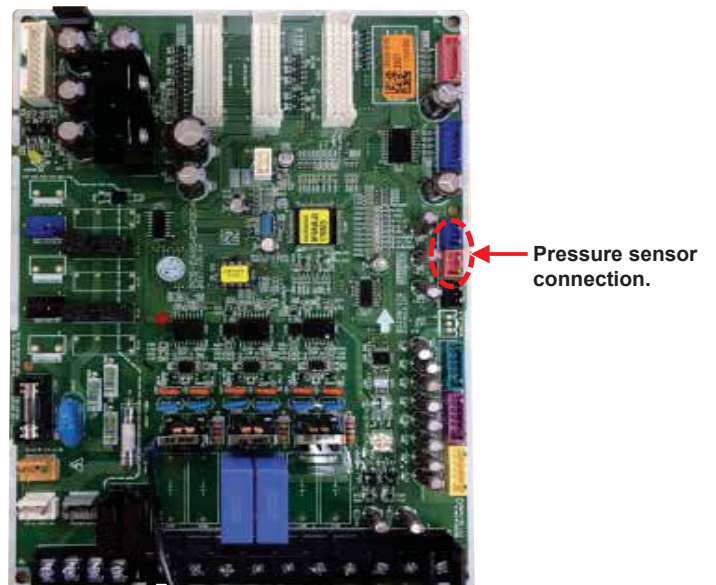
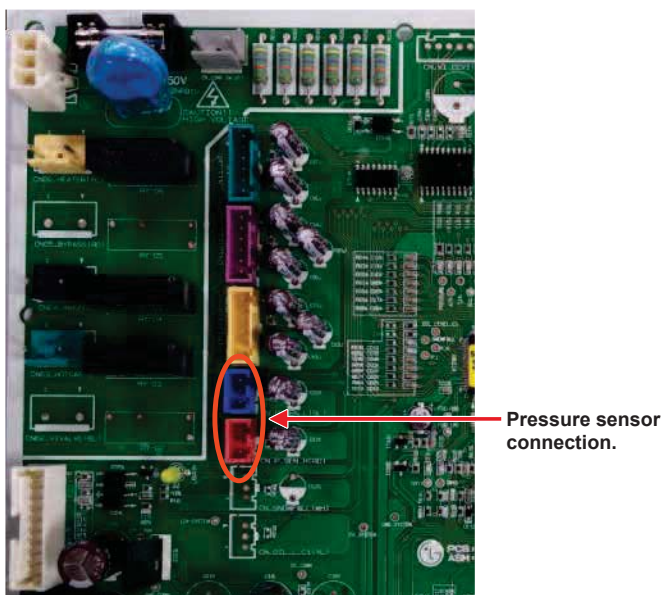

⚠ WARNING Please refer to the Safety Precautions on pages 4-7 for more detail to prevent injury or death regarding the operation and service troubleshooting of the Multi V product.

Error No.	Description	Details	Causes
44	Outdoor unit ambient air temperature sensor error.	Disconnection or short circuit of outdoor unit compressor discharge temperature sensor.	1. Check the connection on the outdoor unit PCB. 2. Thermistor shorted or opened.
45	Outdoor unit heat exchanger pipe temperature sensor error.	Disconnection or short circuit of outdoor unit heat exchanger piping temperature sensor.	
46	Outdoor unit compressor suction pipe temperature sensor error.	Disconnection or short circuit of outdoor unit compressor suction piping temperature sensor.	1. Check the connection on the outdoor unit PCB. 2. Thermistor shorted or opened. 3. Check suction sensor in cooling mode; check hot gas sensor located near the heat exchanger in heating mode.

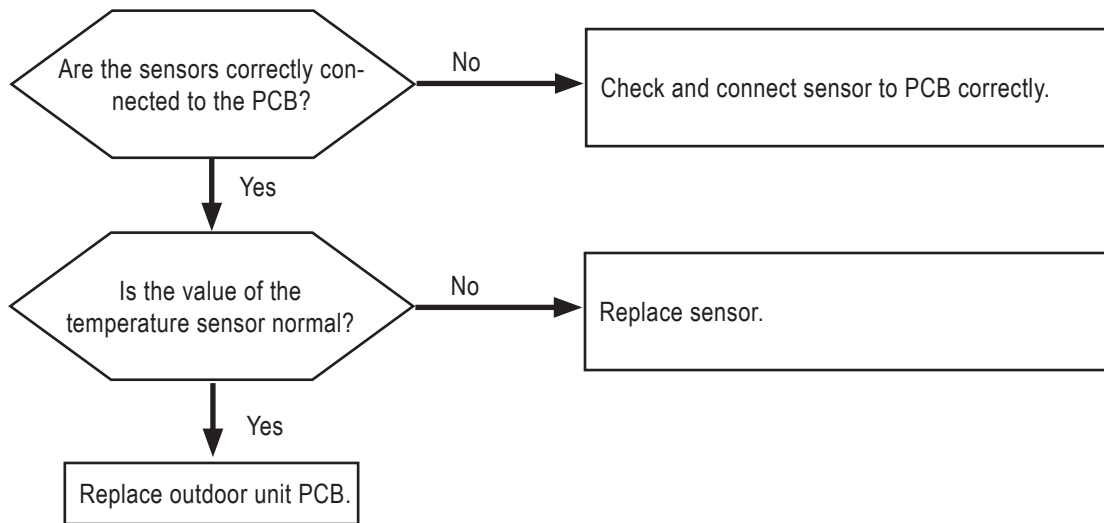

- If the value is >100kΩ (open) or <100Ω (short), there is an error.
- Sensor resistance value will vary with the temperature. See below for the resistance values according to temperature (±5% tolerance).
- Air temperature sensor: 50°F = 20.7 kΩ, 77°F = 10 kΩ, 122°F = 3.4 kΩ.
- Pipe temperature sensor: 50°F = 10 kΩ, 77°F = 5 kΩ, 122°F = 1.8 kΩ.

ERROR CODES

Error No. 50



WARNING Please refer to the Safety Precautions on pages 4-7 for more detail to prevent injury or death regarding the operation and service troubleshooting of the Multi V product.

Error No.	Description	Details	Causes
50	Outdoor unit loss of phase.	Input power line connection(s) is / are missing for the outdoor unit.	<ol style="list-style-type: none"> 1. Input voltage is not correct. Power wiring connections could not be correct. 2. Noise filter and / or connection error. 3. Main PCB could be damaged. 4. Inverter PCB input current sensor error.

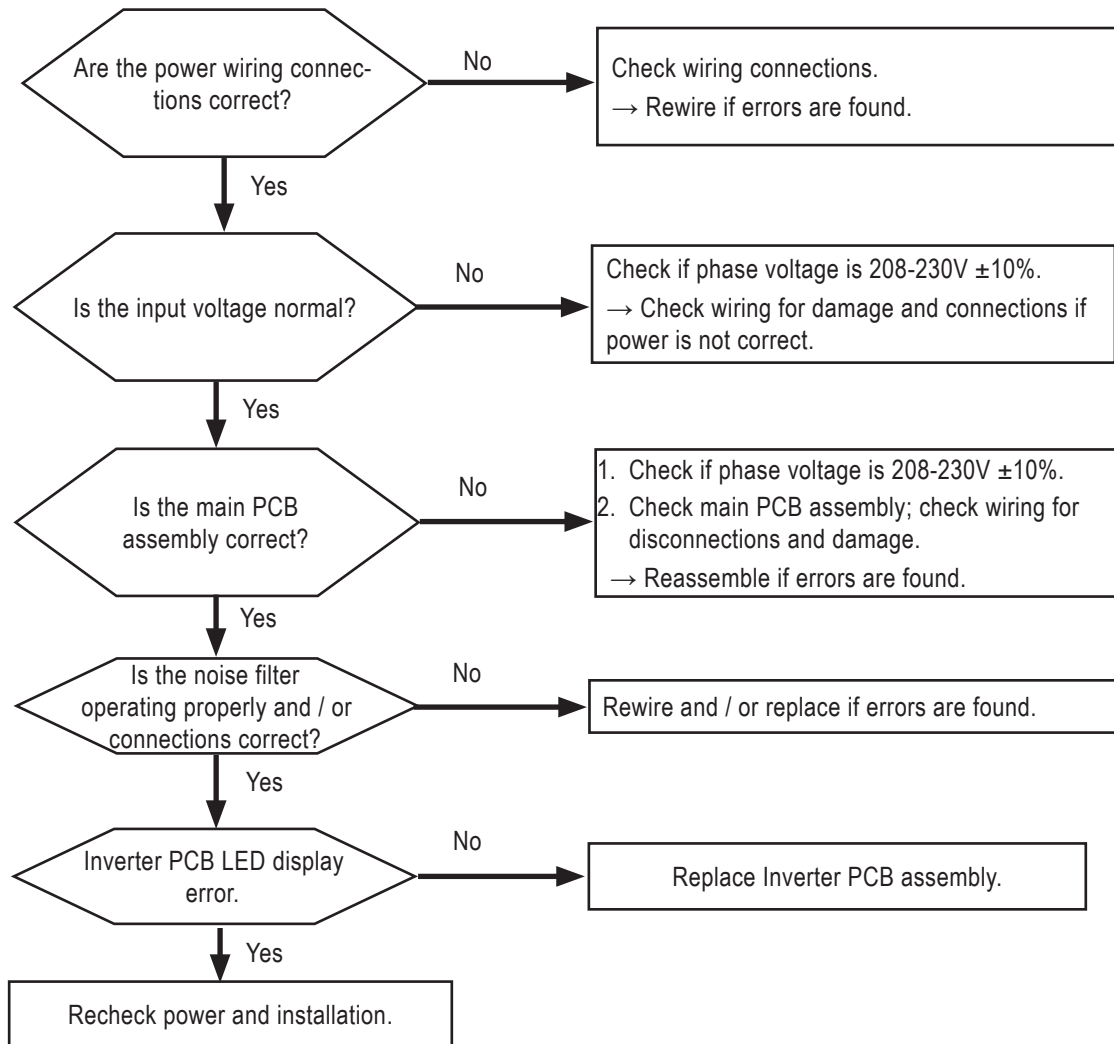

⚠ WARNING Please refer to the Safety Precautions on pages 4-7 for more detail to prevent injury or death regarding the operation and service troubleshooting of the Multi V product.

Error No.	Description	Details	Causes
51	Combination ratio is out of range.	Value of total indoor unit capacity exceeds allowable outdoor unit capacity specifications.	<ol style="list-style-type: none"> 1. Total indoor unit capacity is more than 130% outdoor unit rated capacity. 2. Wrong communication cable / piping connections.. 3. Defective outdoor unit PCB.

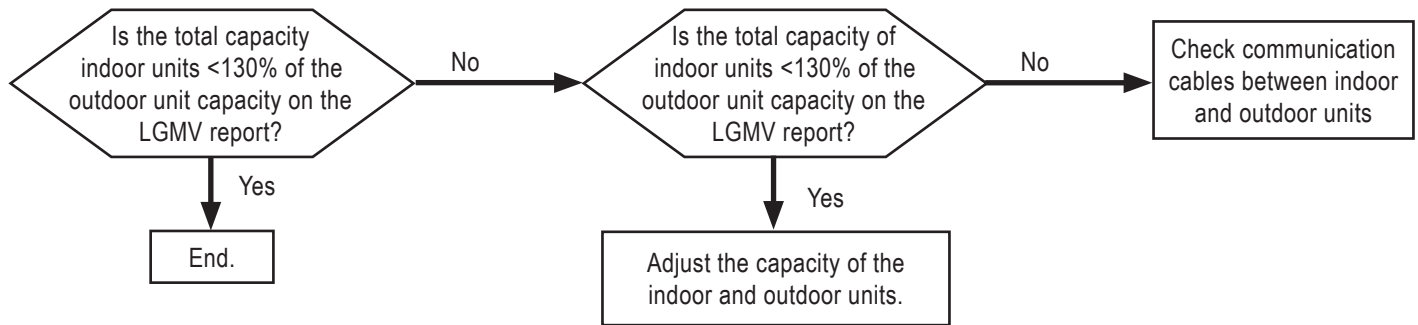

ERROR CODES

Error No. 52

⚠ WARNING Please refer to the Safety Precautions on pages 4-7 for more detail to prevent injury or death regarding the operation and service troubleshooting of the Multi V product.

Error No.	Description	Details	Causes
52	Communication error between outdoor unit inverter compressor PCB(s) and main PCB.	Outdoor unit main controller (PCB) cannot receive signal from inverter compressor controller (PCB[s]).	<ol style="list-style-type: none"> 1. Power wiring or communication cable is disconnected. 2. Defective outdoor unit inverter compressor PCB.

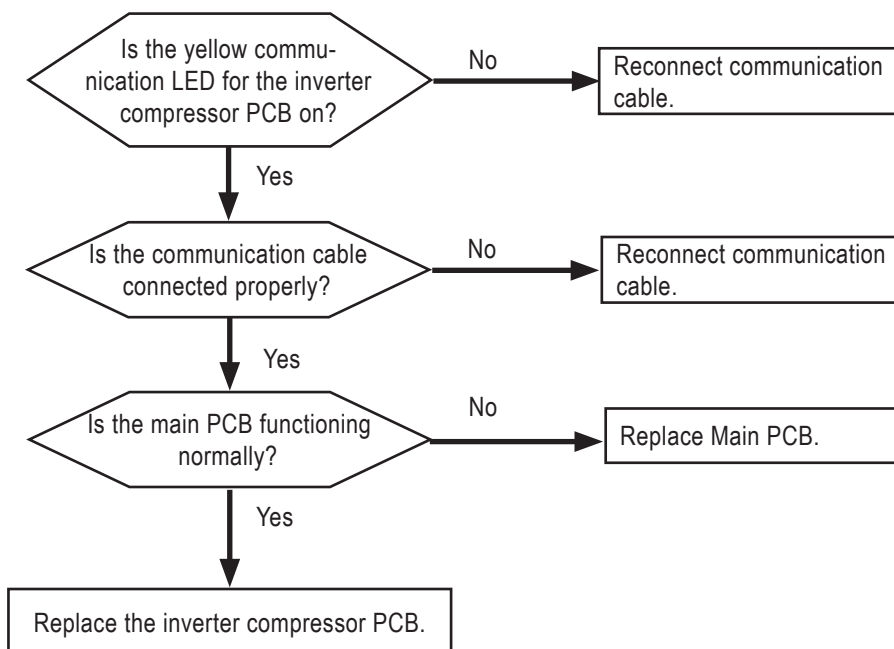

Checking the Main PCB and Inverter PCB (If Normal, Communication LED Blinks).

Figure 57: ARUN024 to 053GSS4 Error No. 52 Checking the Inverter Compressor Connections.

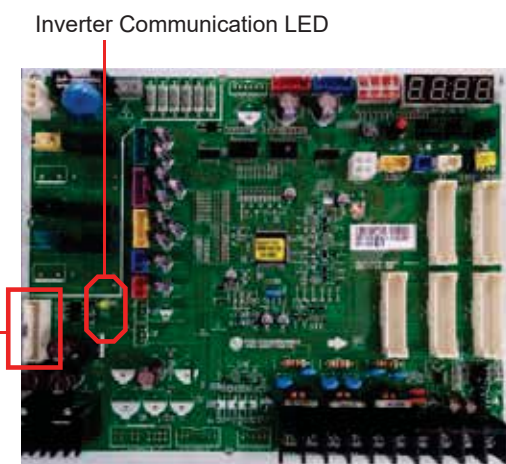
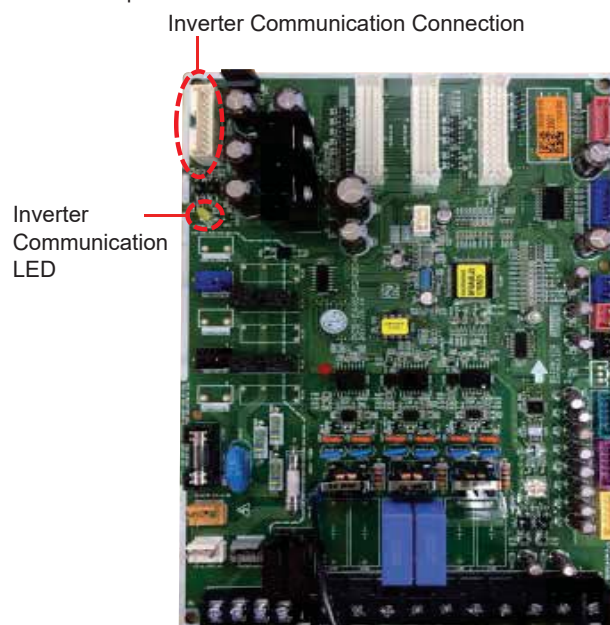

Figure 58: ARUN060GSS4 and ARUB060GSS4 Error No. 52 Checking the Inverter Compressor Connections.



Note:

Images here are representative of system components. Actual component appearance depends on model and system type.

⚠ WARNING Please refer to the Safety Precautions on pages 4-7 for more detail to prevent injury or death regarding the operation and service troubleshooting of the Multi V product.

Error No.	Description	Details	Causes
53	Communication error between outdoor unit main PCB and indoor unit(s) PCB.	Outdoor unit main PCB cannot receive the signal from the indoor unit.	<ol style="list-style-type: none"> 1. Communication cables are not connected between external PCB and indoor PCB. 2. Communications cables are disconnected or have short circuited between the main PCB and external PCB. 3. Communication cables are disconnected or have short circuited between the main PCB and communication PCB. 4. Communication cables are disconnected or have short circuited (communication cable connection error.) 5. Power to the indoor PCB is off. 6. Defective outdoor unit main PCB, communication PCB, and / or indoor unit PCB.

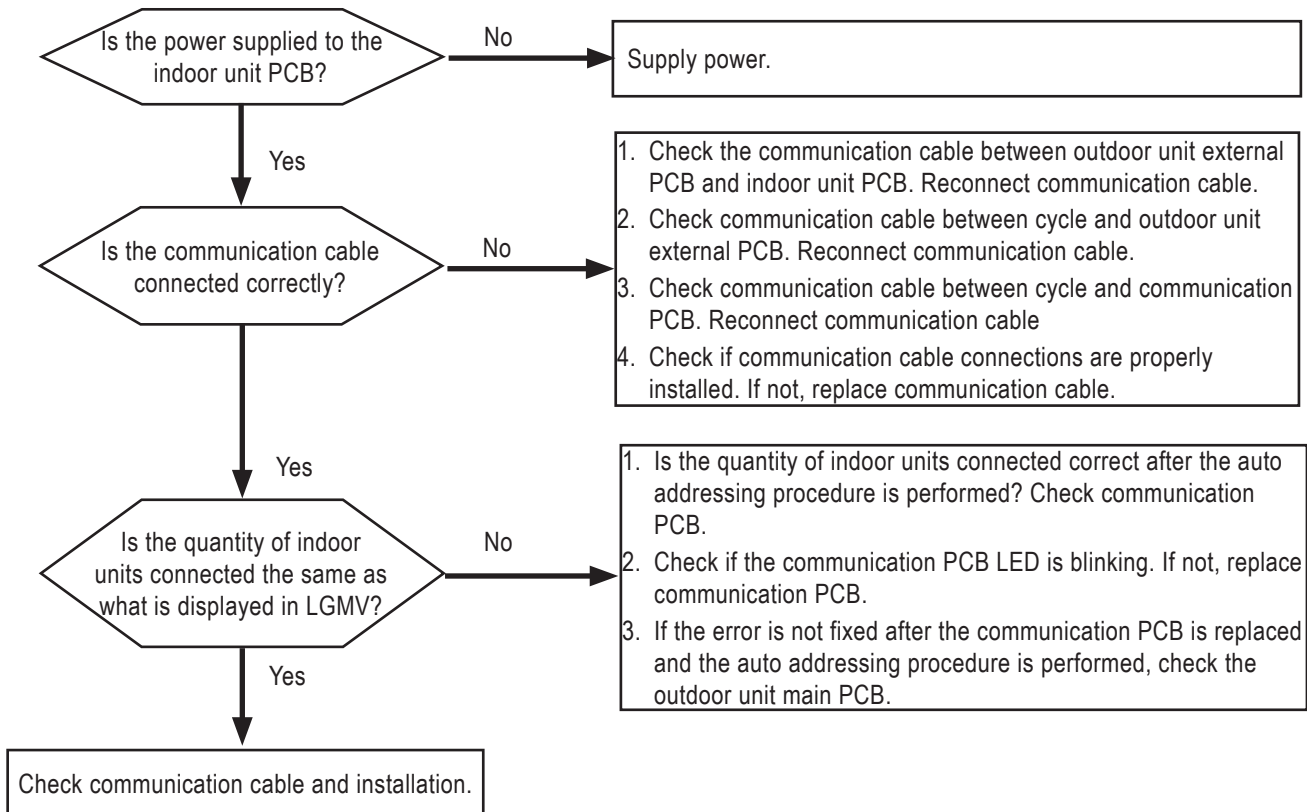

Error Codes

ERROR CODES

Error No. 53, continued.

⚠ WARNING Please refer to the Safety Precautions on pages 4-7 for more detail to prevent injury or death regarding the operation and service troubleshooting of the Multi V product.

Error No. 53 indicates there is a communication error between the outdoor unit and indoor unit(s). See LGMV to help determine which indoor unit or units are not communicating with the outdoor unit.

- Does LGMV display the correct number of indoor units? If LGMV DOES NOT display the correct number of indoor units, find the missing indoor unit or units and troubleshoot.
- If LGMV DOES displays the correct number of indoor units, but the outdoor unit still shows CH53, check the communication count line on LGMV. Find the indoor unit that does not have a communication count increase—that indicates the indoor unit which is not communicating. The indoor unit can have:

1. Wrong communication cable or power wiring connection(s).
2. A PCB malfunction.
3. Duplicate address numbers for indoor units (Error No. 53 will appear at the indoor unit).

Note:

- If communication in general is not functioning properly, then the auto addressing procedure has not been performed yet or has not been performed properly.
- Auto addressing must be performed after an indoor unit PCB has been replaced. Also, if a central controller is installed, the central controller address must be input.
- In addition to the information presented here, see also troubleshooting procedure for Error No. 05.

LGMV Communication Line Example

IDU Gr. 1		More HR Info						More IdU Info	
	comm.	CEN	error	humidity	H/L	TGT	TGT2		
IDU1	38	6	0	0	0	0	0		
IDU2	39	2	0	0	0	0	0		
IDU3	38	8	0	0	0	0	0		
IDU4	37	1	0	0	0	0	0		
IDU5	37	0	0	0	0	0	0		
IDU6	37	5	0	0	0	0	0		
IDU7	38	7	0	0	0	0	0		
IDU8	38	4	0	0	0	0	0		

Figure 59: ARUN024 to 053GSS4 Error No. 53 Checking the PCB Connections.

Communication Connections on Main PCB

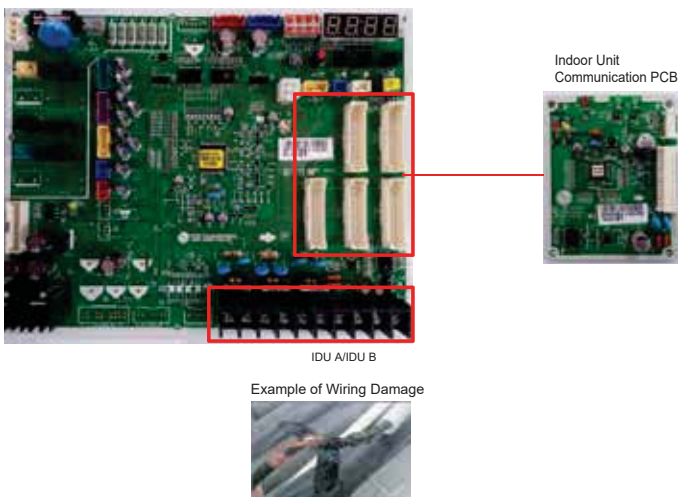
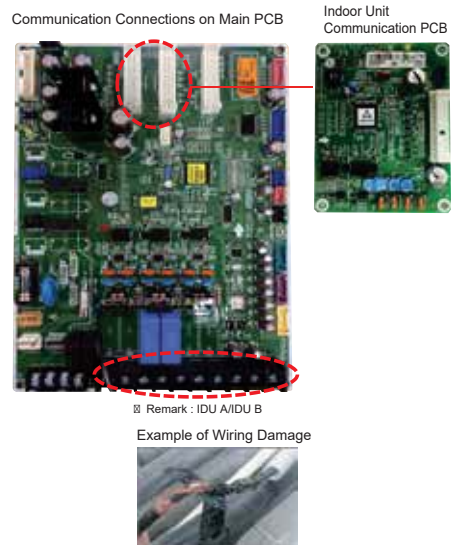

Figure 60: ARUN060GSS4 and ARUB060GSS4 Error No. 53 Checking the PCB Connections.



Note:

Images here are representative of system components. Actual component appearance depends on model and system type.

⚠ WARNING Please refer to the Safety Precautions on pages 4-7 for more detail to prevent injury or death regarding the operation and service troubleshooting of the Multi V product.

Error No.	Description	Details	Causes
57	Communication error between outdoor unit main PCB and inverter PCB.	Outdoor unit inverter PCB is not receiving signal from main PCB.	<ol style="list-style-type: none"> 1. Bad connection between main and inverter PCBs. 2. Communication wire noise effect. 3. The outdoor unit main PCB is damaged. 4. The outdoor unit inverter PCB is damaged.

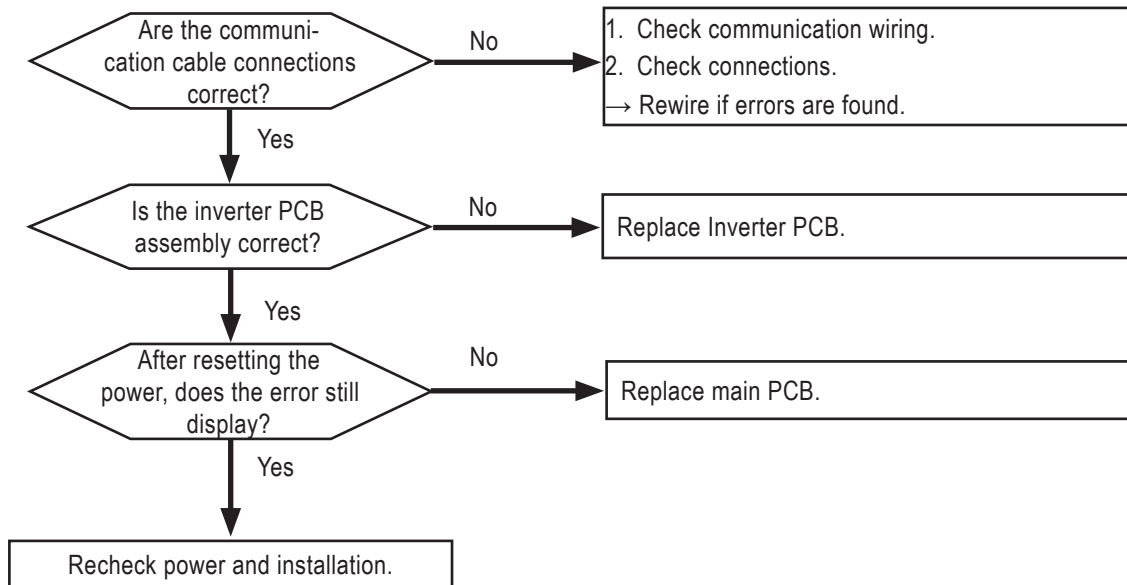

Error Codes

Figure 61: ARUN024 to 053GSS4 Error No. 57 Checking the PCB Connections.

Figure 62: ARUN060GSS4 and ARUB060GSS4 Error No. 57 Checking the PCB Connections.

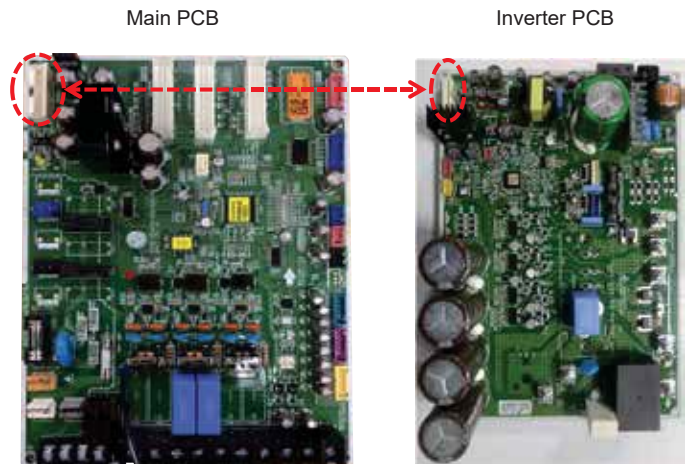
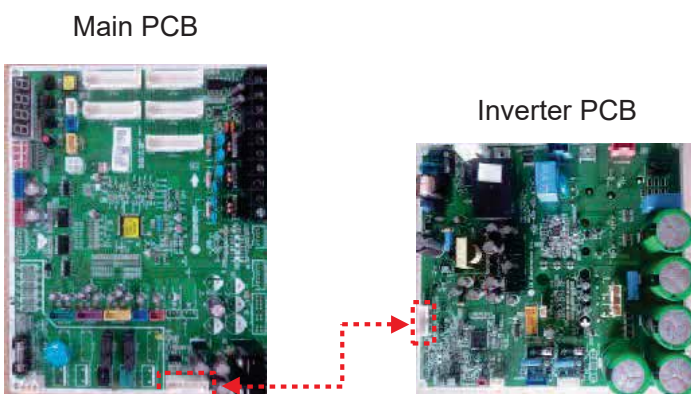

Note:

Images here are representative of system components. Actual component appearance depends on model and system type.

ERROR CODES

Error No. 60

⚠ WARNING Please refer to the Safety Precautions on pages 4-7 for more detail to prevent injury or death regarding the operation and service troubleshooting of the Multi V product.

Error No.	Description	Details	Causes
60	Outdoor unit inverter PCB EEPROM error.	EEPROM access and "Check SUM" errors.	<ol style="list-style-type: none"> EEPROM contact is defective, or the contact is not inserted correctly. Different EEPROM version. Outdoor unit inverter PCB assembly is damaged.

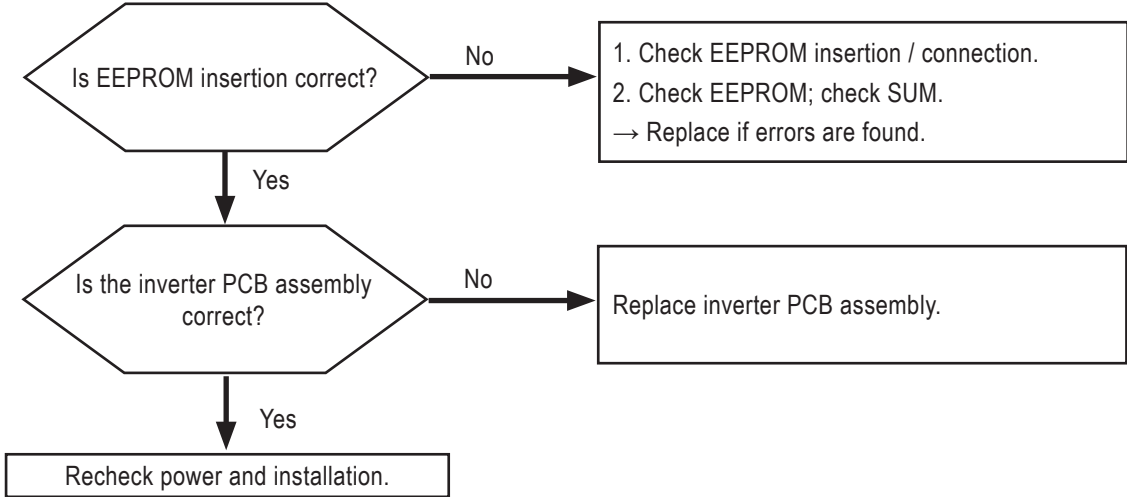

⚠ WARNING

Replace EEPROM only after the power is turned off. There is a risk of electric shock that could cause physical injury or death.

Figure 63: ARUN024 to 053GSS4 Error No. 60 Checking the PCB Connections.

Inverter EEPROM Connection.

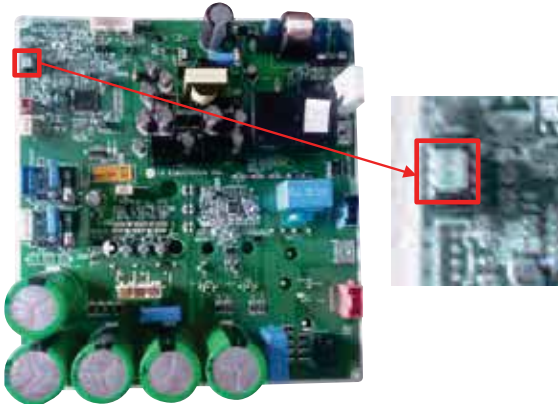

Correct Inverter EEPROM Installation Direction.

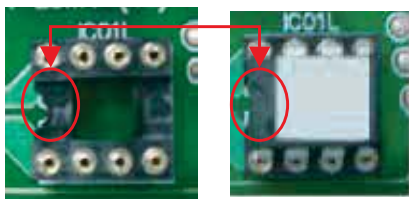

Note:

Images here are representative of system components. Actual component appearance depends on model and system type.

Figure 64: ARUN060GSS4 and ARUB060GSS4 Error No. 60 Checking the PCB Connections.

Inverter EEPROM Connection.



Correct Inverter EEPROM Installation Direction.

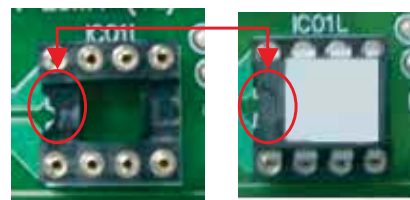

WARNING Please refer to the Safety Precautions on pages 4-7 for more detail to prevent injury or death regarding the operation and service troubleshooting of the Multi V product.

Error No.	Description	Details	Causes
62	High temperature at the outdoor unit inverter PCB heat sink.	Heat sink temperature is >257°F.	<ol style="list-style-type: none"> 1. Inverter PCB IPM connection is not correct. 2. Outdoor unit fan motor operation is malfunctioning. 3. Outdoor unit inverter PCB assembly is defective. 4. Overload operation (pipe is clogged, fan is blocked, EEV is defective, overcharge in refrigerant).

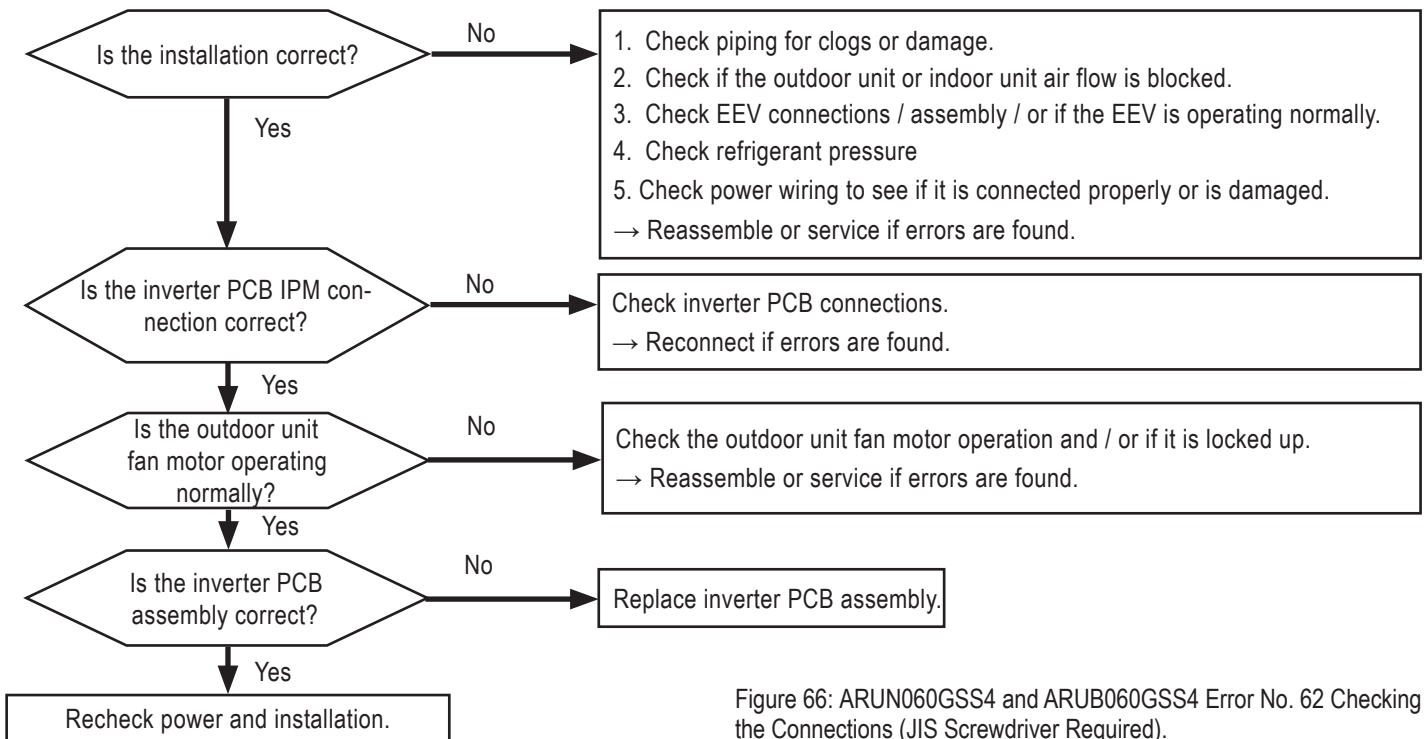

Figure 66: ARUN060GSS4 and ARUB060GSS4 Error No. 62 Checking the Connections (JIS Screwdriver Required).

Check Connections.

Checking the Inverter PC Connections.

Figure 65: ARUN024 to 053GSS4 Error No. 62 Checking the Connections (JIS Screwdriver Required).

Check Connections.

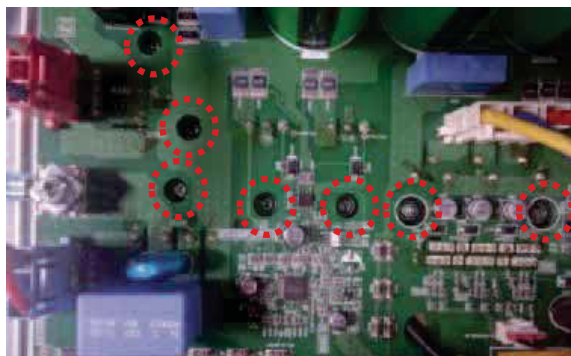

Note:

Images here are representative of system components. Actual component appearance depends on model and system type.

Note:

Always apply heat transfer paste to the new inverter PCB heat sink before installing. For instructions, see "Replacing the Inverter PCB Heat Sink" page later in this section.



ERROR CODES

Error No. 65

⚠ WARNING Please refer to the Safety Precautions on pages 4-7 for more detail to prevent injury or death regarding the operation and service troubleshooting of the Multi V product.

Error No.	Description	Details	Causes
65	Outdoor unit liquid pipe (condenser) temperature sensor error.	Abnormal sensor resistance value.	<ol style="list-style-type: none"> 1. Defective temperature sensor connection. 2. Defective temperature sensor (sensor has opened or shorted). 3. Defective outdoor unit PCB.

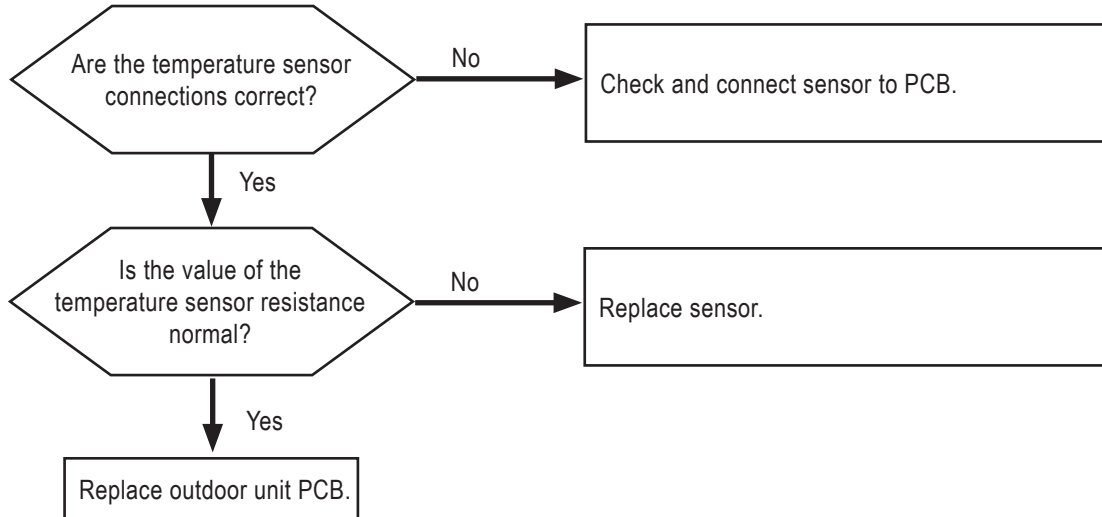

- If the value is >100kΩ (open) or <100Ω (short), there is an error.
- Sensor resistance value will vary with the temperature. See below for the resistance values according to temperature (±5% tolerance).
- Air temperature sensor: 50°F = 20.7 kΩ, 77°F = 10 kΩ, 122°F = 3.4 kΩ.
- Pipe temperature sensor: 50°F = 10 kΩ, 77°F = 5 kΩ, 122°F = 1.8 kΩ.

Note:

See also Error Code No. 113, Outdoor Unit Liquid Pipe (Condenser) Temperature Sensor Error.

WARNING Please refer to the Safety Precautions on pages 4-7 for more detail to prevent injury or death regarding the operation and service troubleshooting of the Multi V product.

Error No.	Description	Details	Causes
67	Outdoor unit fan has locked up.	RPM is ≤ 10 RPM for five (5) seconds when the outdoor unit fan starts, or ≤ 40 RPM after fan starts.	<ol style="list-style-type: none"> 1. Fan motor is defective or assembly is not correct. 2. Fan motor connection is wrong (U,V,W output). 3. Rotation has reversed after RPM target is achieved. 4. Fan PCB assembly is defective. 5. Fan air flow is blocked by heavy snowfall.

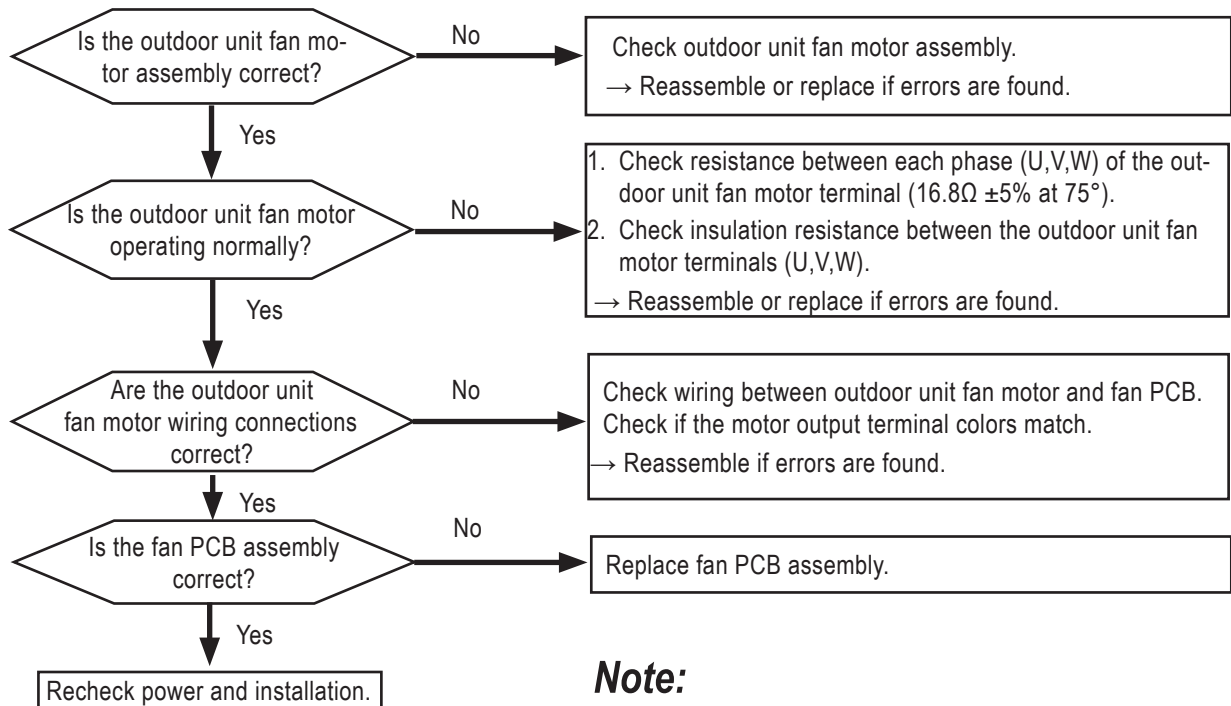

Note:

If the outdoor unit is covered in thick snow, remove before operating system.

Figure 67: ARUN024 to 053GSS4 Error No. 67 Checking the PCB Connections.

Inverter PCB

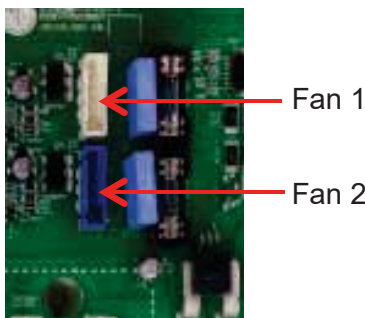
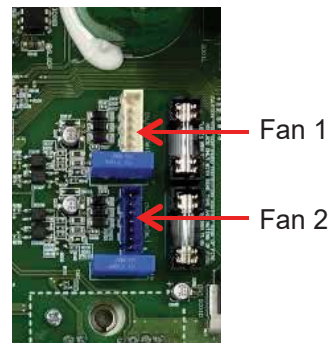

Figure 68: ARUN060GSS4 and ARUB060GSS4 Error No. 67 Checking the PCB Connections.

Inverter PCB



Note:

Images here are representative of system components. Actual component appearance depends on model and system type.

ERROR CODES

Error No. 86

⚠ WARNING Please refer to the Safety Precautions on pages 4-7 for more detail to prevent injury or death regarding the operation and service troubleshooting of the Multi V product.

Error No.	Description	Details	Causes
86	Outdoor unit main PCB onboard EEPROM error.	EEPROM access error.	1. No EEPROM. 2. EEPROM is not inserted properly.

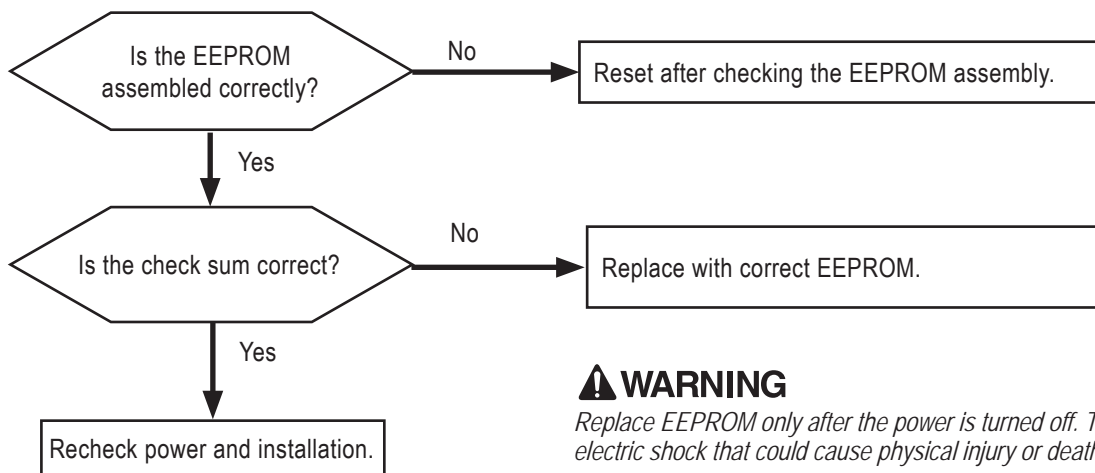

⚠ WARNING

Replace EEPROM only after the power is turned off. There is a risk of electric shock that could cause physical injury or death.

Note:

Images here are representative of system components. Actual component appearance depends on model and system type.

Figure 69: ARUN024 to 053GSS4 Error No. 87 Checking the EEPROM.

Inserting the EEPROM.

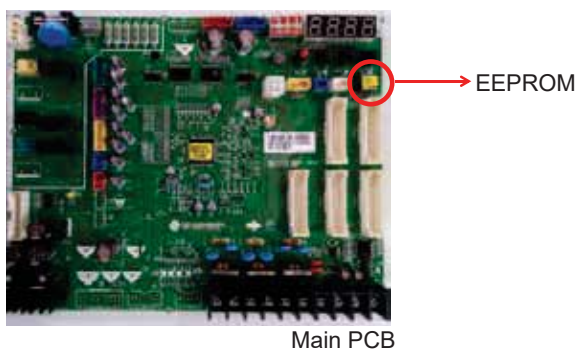

Correct Inverter EEPROM Installation Direction (Same direction for both the socket and EEPROM holes).

Figure 70: ARUN060GSS4 and ARUB060GSS4 Error No. 87 Checking the EEPROM.

Inserting the EEPROM.

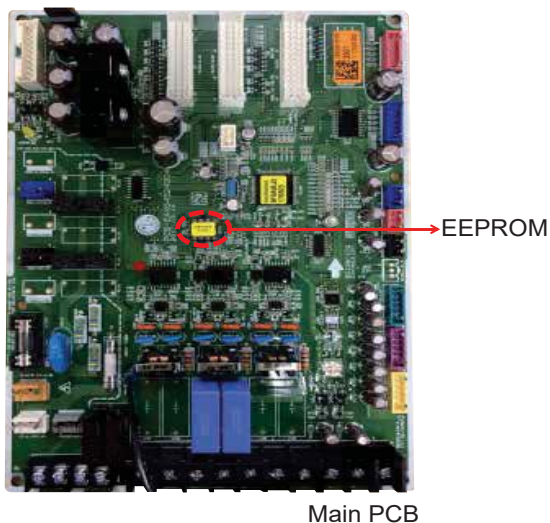

Correct Inverter EEPROM Installation Direction (Same direction for both the socket and EEPROM holes).

⚠ WARNING Please refer to the Safety Precautions on pages 4-7 for more detail to prevent injury or death regarding the operation and service troubleshooting of the Multi V product.

Error No.	Description	Details	Causes
113	Outdoor unit liquid pipe (condenser) temperature sensor error.	Disconnection or short of outdoor unit liquid pipe (condenser) temperature sensor (sensor value is abnormal).	1. Defective temperature sensor connection. 2. Temperature sensor has opened or shorted. 3. Defective outdoor unit PCB.
115	Outdoor unit subcooling outlet temperature sensor error.	Disconnection or short circuit of outdoor unit subcooling outlet temperature sensor (sensor value is abnormal).	

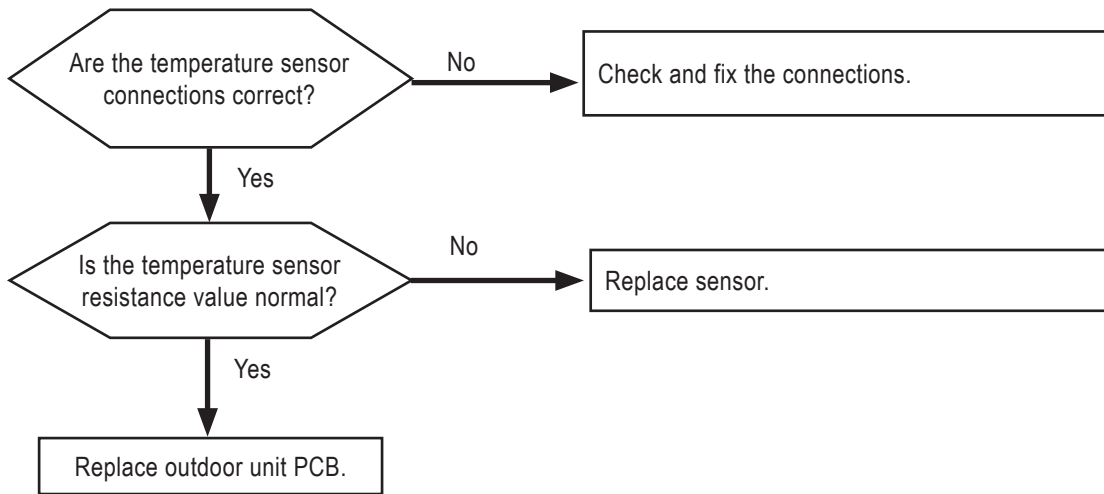

- If the value is >100kΩ (open) or <100Ω (short), there is an error.
- Sensor resistance value will vary with the temperature. See below for the resistance values according to temperature (±5% tolerance).
- Air temperature sensor: 50°F = 20.7 kΩ, 77°F = 10 kΩ, 122°F = 3.4 kΩ.
- Pipe temperature sensor: 50°F = 10 kΩ, 77°F = 5 kΩ, 122°F = 1.8 kΩ.

Note:

See also Error Code No. 65: Outdoor Unit Liquid Pipe (Condenser) Temperature Sensor Error.

ERROR CODES

Error No. 1501

⚠ WARNING Please refer to the Safety Precautions on pages 4-7 for more detail to prevent injury or death regarding the operation and service troubleshooting of the Multi V product.

Error No.	Description	Details	Causes
1501	Outdoor unit compressor discharge superheat not satisfied. (ARUN / ARUB60GSS4 only)	<p>Code indicates that based on current superheat measurements, there is a high possibility of liquid refrigerant flooding back and damaging the compressor.</p> <p>Discharge superheat is $<4.8^{\circ}\text{F}$ (liquid bypass) for ≥ 5 minutes.</p> <p>Code can only occur when the outdoor is operating in cooling mode (all indoor units must be in cooling mode; error cannot occur during simultaneous operation).</p> <p>The first time superheat falls below $<4.8^{\circ}\text{F}$ ($<3^{\circ}\text{C}$) for 5 minutes, the system will shut down and CH1501 is displayed on all indoor unit zone sensors and central control devices. After the initial occurrence, the outdoor unit cycles off and will auto-restart.</p> <p>Following the initial restart, and after 10 minutes of operation to allow the system time to stabilize, if the superheat again falls $<4.8^{\circ}\text{F}$ ($<3^{\circ}\text{C}$) for 5 minutes, the system will shut down and auto restart for a second time.</p> <p>If error occurs 3 times within any 1 hour period of compressor operation, the error code will be assigned a Level 3, and the system will shut down and remain off. A manual restart will be necessary.</p>	<p>After at least 10 minutes of compressor operation, the master outdoor unit microprocessor will calculate the system's compressor superheat. If at any time during compressor operation where all indoor units in thermal on are in cooling mode and the compressor superheat falls $<4.8^{\circ}\text{F}$ ($<3^{\circ}\text{C}$) for ≥ 5 minutes, there is a high probability that liquid could flood back to the inlet of the compressor scroll, resulting in compressor damage.</p> <ol style="list-style-type: none"> 1. Indoor unit EEV has disconnected or short circuited. 2. Defective compressor EEV (large refrigerant leak has occurred). 3. Defective liquid piping and / or vapor piping connections.

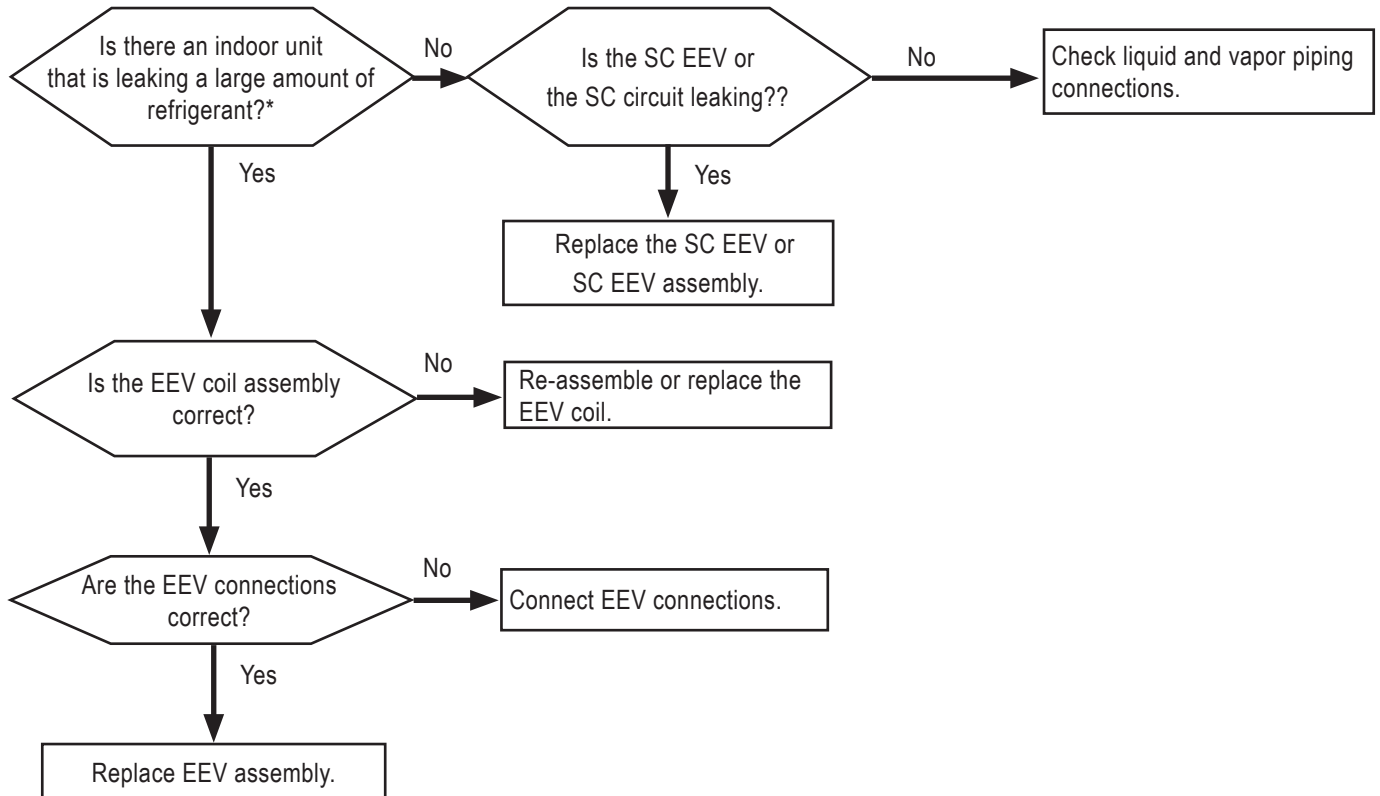

*Excessive refrigerant leak: Both the piping inlet and outlet temperatures are $<50^{\circ}\text{F}$ when the indoor unit is off (EEV 40 pulses). Also, a loud refrigerant flow noise was heard.

WARNING Please refer to the Safety Precautions on pages 4-7 for more detail to prevent injury or death regarding the operation and service troubleshooting of the Multi V product.

Error No.	Description	Details	Causes
151	The difference between the high and low pressure is too low.	Not enough pressure difference between high and low. Function error of outdoor unit four-way reversing valve.	<ol style="list-style-type: none"> 1. Problem with four-way valve operation because of sludge, inflow, etc. 2. No pressure difference because of compressor error. 3. Incorrect installation of outdoor unit to indoor unit piping. 4. Defective four-way valve (resistance is not $2,085\Omega \pm 10\%$).

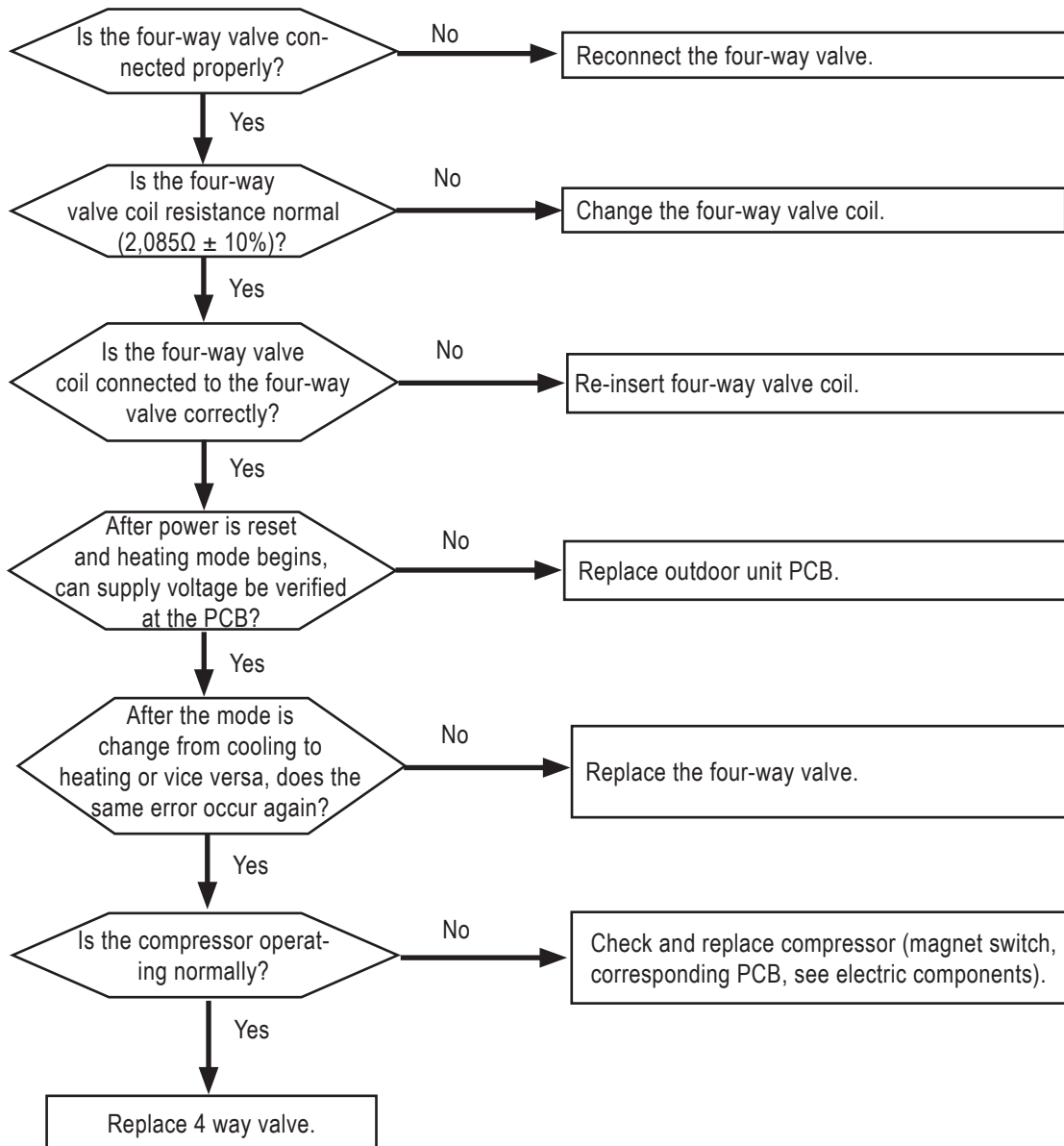

Note:

To get the valve to switch, close the outdoor unit hot gas service valve, then put the system in heat mode, and if pressure builds, slowly open the hot gas valve.

ERROR CODES

Error No. 151, continued.

⚠ WARNING Please refer to the Safety Precautions on pages 4-7 for more detail to prevent injury or death regarding the operation and service troubleshooting of the Multi V product.

Location of the four-way valve connector on the Main PCB (marked as "4way, CN09").

Measure the four-way valve resistance.

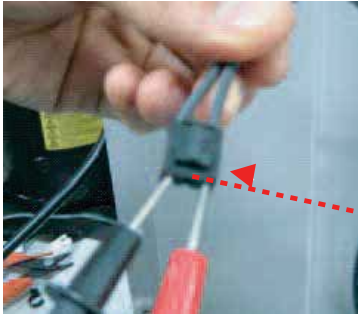

ARUN24~53GSS4 Main PCB

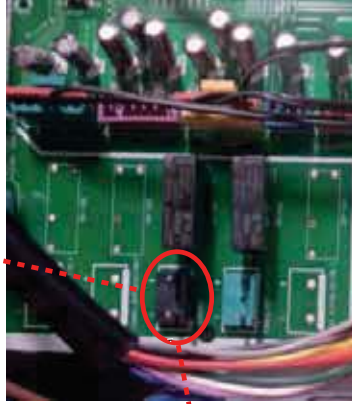

ARUN / ARUB60GSS4 Main PCB



Confirm the four-way valve coil is completely inserted.

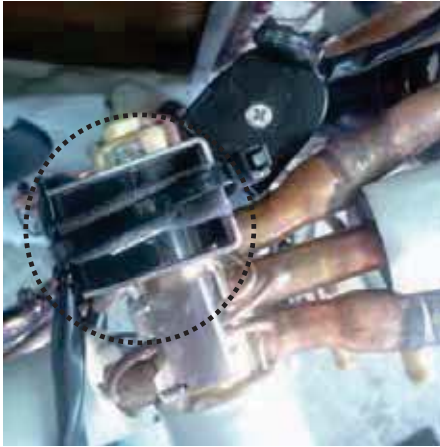

Check the output voltage of the terminal socket during heating operation (output must be 230 V AC).

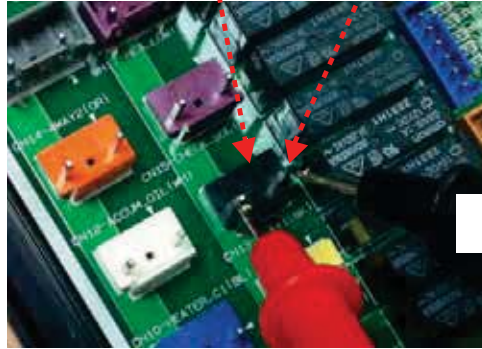

MULTI V S Outdoor Unit Service Manual



WARNING Please refer to the Safety Precautions on pages 4-7 for more detail to prevent injury or death regarding the operation and service troubleshooting of the Multi V product.

Error No.	Description	Details	Causes
51 C+ No. (#) of Heat Recovery Unit	Capacity of indoor units connected to the heat recovery unit exceeds allowable limits.	Total capacity of indoor unit(s) connected to each heat recovery unit port exceeds allowable limits. Error code displays on the outdoor unit SSD, the heat recovery unit SSD, or in LGMV.	<p>After auto-pipe detection is complete, wait 5 minutes, then verify connected capacity. System will display error if:</p> <ul style="list-style-type: none"> • The heat recovery unit port addresses are all unique, then >54 Mbh single indoor unit connected; >54 Mbh total of multiple indoor units connected. • If 2 heat recovery unit port addresses are the same and the ports are twinned; >108 Mbh total of multiple indoor units are connected. • If 3 heat recovery unit port addresses are the same and the ports are all connected, >162 Mbh total of multiple indoor units connected. • If the total connected indoor unit nominal capacity exceeds 192 Mbh for a single heat recovery unit. <ol style="list-style-type: none"> 1. Communication cable or piping is not connected properly. 2. Heat recovery PCB DIP switch is not set correctly. 3. The indoor unit connected on the heat recovery unit port exceeds the allowable capacity limit.

Error Code 51 C+ No. (#) of Heat Recovery Unit is displayed differently depending on which device it is viewed from:

1. If viewed from the master outdoor units SSD: The display shows “51c” where “c” is the heat recovery unit count number of the overconnected device assigned by auto-pipe detect.
2. If viewed from the heat recovery unit PCB board display that is overconnected: The display will show “CH51”.
3. If viewed from an heat recovery unit that is not overconnected: The display will show nothing.
4. If viewed from any indoor unit zone controller: Nothing will be displayed.
5. If viewed from LGMV maintenance software on a PC: The screen will show CH51h where “h” is the heat exchanger address of the overconnected heat recovery unit.

1. Check if the communication cable and piping between the heat recovery unit(s) and the indoor unit(s) installed correctly.
2. Check if the DIP switches are set correctly for each connection condition between the heat recovery unit(s) and the indoor unit(s)
3. If the indoor unit connected to the heat recovery unit IS in a group control application, check if the corresponding capacity is ≤100 kBtu.
4. If the indoor unit connected to the heat recovery unit IS NOT in a group control application, check if the corresponding capacity is ≤56 kBtu (including zoning control).
5. If the error occurs again even after following Steps 1 through 4 above, replace the corresponding heat recovery unit PCB.
6. When Steps 1 through 4 (or Steps 1 through 5 if the heat recovery unit PCB needs to be replaced) are completed successfully, perform the auto addressing and piping detection procedures.

ERROR CODES



Error No. 2001

⚠ WARNING Please refer to the *Safety Precautions* on pages 4-7 for more detail to prevent injury or death regarding the operation and service troubleshooting of the Multi V product.

Error No.	Description	Details	Causes
2001	Auto pipe search failure.	After auto operation, the number of the indoor units detected is different from the number of communicating indoor units.	<ol style="list-style-type: none"> 1. Power wiring or the communications cable to the heat recovery unit is defective. 2. After auto addressing, indoor unit has the wrong address (defective indoor unit PCB and / or power wiring / communications cable). 3. Heat recovery unit rotary or DIP switch setting(s) is (are) wrong. 4. Heat recovery unit PCB is defective.

1. See if the green communication LED of the heat recovery unit is blinking.
2. If the green communication LED of the heat recovery unit is consistently blinking:
 - Check the input power of the heat recovery unit.
 - Reset power to the outdoor unit and heat recovery unit, wait for ≥thirty (30) minutes so the piping temperature will cool down, and then perform the auto addressing procedure.
 - While the power to the heat recovery unit is on, check if error code “CH05” is displayed (see troubleshooting instructions for Error No. CH05).
3. If the green communication LED of the heat recovery unit is still consistently blinking, check the rotary switch and DIP switch settings. Reset power to the outdoor unit and heat recovery unit, wait for ≥thirty (30) minutes so the piping temperature will cool down, and then perform the auto addressing procedure.
4. If the number of indoor units is different than what is actually installed and what number is displayed after the auto addressing procedure is finished, check the piping installation. Outdoor unit ↔ Heat Recovery unit ↔ Indoor unit.
5. If an indoor unit has not been connected to the first port (No. 1 Valve) of the heat recovery unit, set the heat recovery unit piping manually.

⚠ WARNING Please refer to the Safety Precautions on pages 4-7 for more detail to prevent injury or death regarding the operation and service troubleshooting of the Multi V product.

Error No.	Description	Details	Causes
201 C+ No. (#) of Heat Recovery Unit	Heat recovery unit liquid piping temperature sensor error.	Abnormal sensor value (sensor has disconnected or has shorted out).	1. Defective temperature sensor connection. 2. Defective temperature sensor (sensor has disconnected or has shorted out). 3. Defective outdoor unit PCB.
202 C+ No. (#) of Heat Recovery Unit	Heat recovery unit subcooling inlet piping temperature sensor error.		
203 C +No. (#) of Heat Recovery Unit	Heat recovery unit subcooling discharge piping temperature sensor error.		

1. Check the connections of the temperature sensor and the lead cable.
2. Is the value of temperature sensor normal? If not, replace sensor (piping temperature sensor: 50°F = 10 kΩ, 77°F = 5 kΩ, 122°F = 1.8 kΩ).
3. If the sensor connection and values are correct, replace the outdoor unit PCB.

Heat Recovery Unit	HR No. 1	HR No. 2	HR No. 3	HR No. 4	HR No. 5	HR No. 6	HR No. 7	HR No. 8	HR No. 9	HR No. 10	HR No. 11	HR No. 12	HR No. 13	HR No. 14	HR No. 15	HR No. 16
Error Displayed	C01	C02	C03	C04	C05	C06	C07	C08	C09	C10	C11	C12	C13	C14	C15	C16

Example of Heat Recovery R unit Error

- #16 Heat Recovery Unit Subcooling Inlet Piping Temperature Sensor Error 200→C16 (Repeated).
- C = Heat Recovery Unit
- # = Heat Recovery Unit Number

ERROR CODES

Error No. 204 C

⚠ WARNING Please refer to the Safety Precautions on pages 4-7 for more detail to prevent injury or death regarding the operation and service troubleshooting of the Multi V product.

Error No.	Description	Details	Causes
204 C+ No. (#) of Heat Recovery Unit	Communication error between outdoor unit and heat recovery unit.	Outdoor unit does not receive signal from heat recovery unit.	<ol style="list-style-type: none"> 1. Heat recovery unit power wiring and / or communication cable connections are defective. 2. Heat recovery unit rotary or DIP switch setting(s) is (are) wrong. 3. Defective heat recovery unit communications PCB (sub PCB). 4. Defective heat recovery unit main PCB.

1. Check power wiring and communication cable connections. Check if the green communication LED on the heat recovery unit PCB is blinking.
2. If the green communication LED is blinking normally, check the rotary and DIP switch settings on the heat recovery unit (See Error No. 200). Reset the power to the outdoor and heat recovery units. (If there is a heat recovery unit communication error, it can't be released until the power to the outdoor unit is reset.)
3. If the green communication LED of the heat recovery unit PCB is not blinking (on continuously), check if the communication of the total indoor units is normal (See Error No. 05). If the green communication LED of the heat recovery unit PCB is not blinking (on continuously), and even if communication to the indoor unit is functioning, replace the heat recovery unit PCB.

⚠ DANGER

- High voltage electricity is required to operate this system. Adhere to the NEC code and these instructions when wiring. Improper connections and inadequate grounding can cause accidental injury or death.
- Turn the power off before servicing the equipment. Electrical shock can cause physical injury or death.
- Do not operate the disconnect switch with wet hands. There is risk of fire, electric shock, physical injury or death.

⚠ WARNING

- Disconnects must only be performed by a properly licensed electrician. Incorrect wiring could cause the disconnect to explode, leading to physical injury or death.
- Do not operate the unit with the panel(s) or protective cover(s) removed. The hot, cold, and high-voltage parts of the unit can cause physical injury or death.
- Do not touch the refrigerant piping during or after operation. It can cause burns or frostbite.

Note:

- If the power wiring and communication cables on the heat recovery unit(s) and indoor unit(s) are not properly connected (connections switched), the communication components will burn out.
- Do not supply power to the unit until all electrical wiring and controls wiring are completed.

Heat Recovery Unit PCB

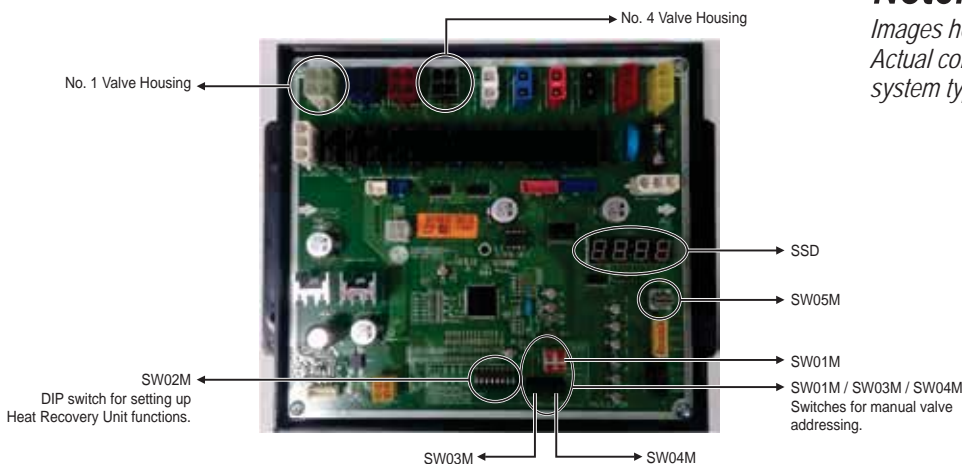

Note:

Images here are representative of system components. Actual component appearance depends on model and system type.

⚠ WARNING Please refer to the Safety Precautions on pages 4-7 for more detail to prevent injury or death regarding the operation and service troubleshooting of the Multi V product.

Error No.	Description	Details	Causes
205 C+ No. (#) of Heat Recovery Unit	Communication error between heat recovery unit and the 485 modem (2A Series Heat Recovery Units).	<p>Communication error occurred between the heat recovery unit and the 485 modem (2A Series Heat Recovery Units).</p> <p>The 2A Series heat recovery unit applies only to heat recovery systems communicating at a baud rate of 9,600 bps.</p> <p>The 485 modem is the communications style on the bus that is 1e outdoor unit to many indoor units.</p>	<ol style="list-style-type: none"> 1. Communication problem occurred between the heat recovery unit PCB and the connection to the communications bus (the heat recovery unit 485 modem). 2. Error displays if the outdoor unit signal is not received for three (3) minutes. The error clears after the signal is received from the modem. (2A Series Heat Recovery Units.) 3. Incorrect wiring between the heat recovery unit and the 485 modem. 4. The 485 PCB modem is defective. 5. The heat recovery unit PCB is defective.

1. Check the communication cable connection between the heat recovery unit (2A Series) and the 485 modem. Check if the red LED is on.
2. If the red LED on the 485 modem is on, reset the outdoor unit and the power of the heat recovery unit.
3. If the red LED on the 485 modem is flashing, replace the 485 modem.
4. If the red LED on the 485 modem still flashes even after it is replaced, replace the heat recovery unit PCB.

ERROR CODES



Error No. 206 C

⚠ WARNING Please refer to the Safety Precautions on pages 4-7 for more detail to prevent injury or death regarding the operation and service troubleshooting of the Multi V product.

Error No.	Description	Details	Causes
206 C+ No. (#) of Heat Recovery Unit	Duplicate address error of the heat recovery unit (2A Series).	<p>The heat recovery unit address is duplicated for 485 communication (2A Series Heat Recovery Units).</p> <ul style="list-style-type: none"> The 2A Series heat recovery unit applies only to heat recovery systems communicating at a baud rate of 9,600 bps. The 485 modem is the communications style on the bus that is 1e outdoor unit to many indoor units. 	<ol style="list-style-type: none"> A heat recovery unit address is duplicated for 485 communication. There are two heat recovery units with one or more HEX addresses that are the same. Adjust the HEX address dial found on the heat recovery units (error of the rotary switch address settings on the heat recovery unit). The power wiring and / or the communication cable connection of the heat recovery unit is defective. The heat recovery unit PCB is defective.

- Check if the rotary switch settings on each heat recovery unit PCB are set correctly. If not, set the rotary switches again, verifying that the settings are different on the different heat recovery units.
- Reset the outdoor unit and the power of the heat recovery unit so that the updated rotary switch settings are applied / saved to the system.
- After Step No. 2 is complete, perform auto addressing again.
- If the error occurs again even after auto addressing is complete, replace the corresponding heat recovery PCB.

- Error Code 206C only occurs on heat recovery units with a 485 modem (2A Series heat recovery units; 9,600 bps communication).
- Refer to the outdoor unit installation manual for heat recovery unit rotary switch address settings.

485 Modem on 2A Series Heat Recovery Units



Note:

Images here are representative of system components. Actual component appearance depends on model and system type.



⚠ WARNING Please refer to the Safety Precautions on pages 4-7 for more detail to prevent injury or death regarding the operation and service troubleshooting of the Multi V product.

Error No.	Description	Details	Causes
237	Communication error between outdoor unit PCB and indoor unit PCB.	Indoor unit communications PCB is not receiving signal from outdoor unit communications PCB for more than 3 minutes. Check RS-485 communications for issues.	<ol style="list-style-type: none"> 1. Check if the outdoor unit has been powered and if auto addressing has occurred. 2. Check communication cable. 3. Check outdoor unit communication module.

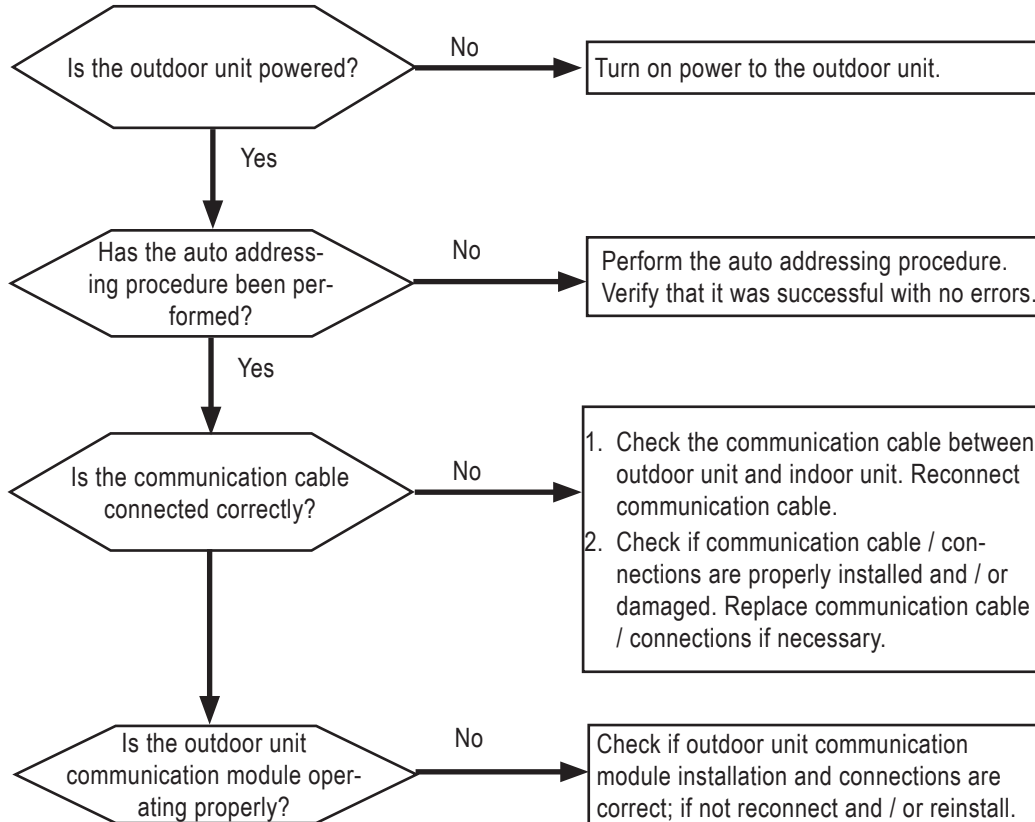

Note:

See also Error Code No. 05: Indoor Unit PCB Communication Error between Outdoor Unit and Indoor Unit, and Error Code No. 238: Outdoor Unit PCB Communication Error Between Indoor Unit and Outdoor Unit.

ERROR CODES

Error No. 238

⚠ WARNING Please refer to the Safety Precautions on pages 4-7 for more detail to prevent injury or death regarding the operation and service troubleshooting of the Multi V product.

Error No.	Description	Details	Causes
238	Communication error between outdoor unit PCB and indoor unit PCB.	Indoor unit communications PCB is not receiving signal from outdoor unit communications PCB for more than 3 minutes. Check outdoor unit PCB communications for issues.	<ol style="list-style-type: none"> 1. Check if the outdoor unit has been powered and if auto addressing has occurred. 2. Check communication cable. 3. Check outdoor unit PCB.

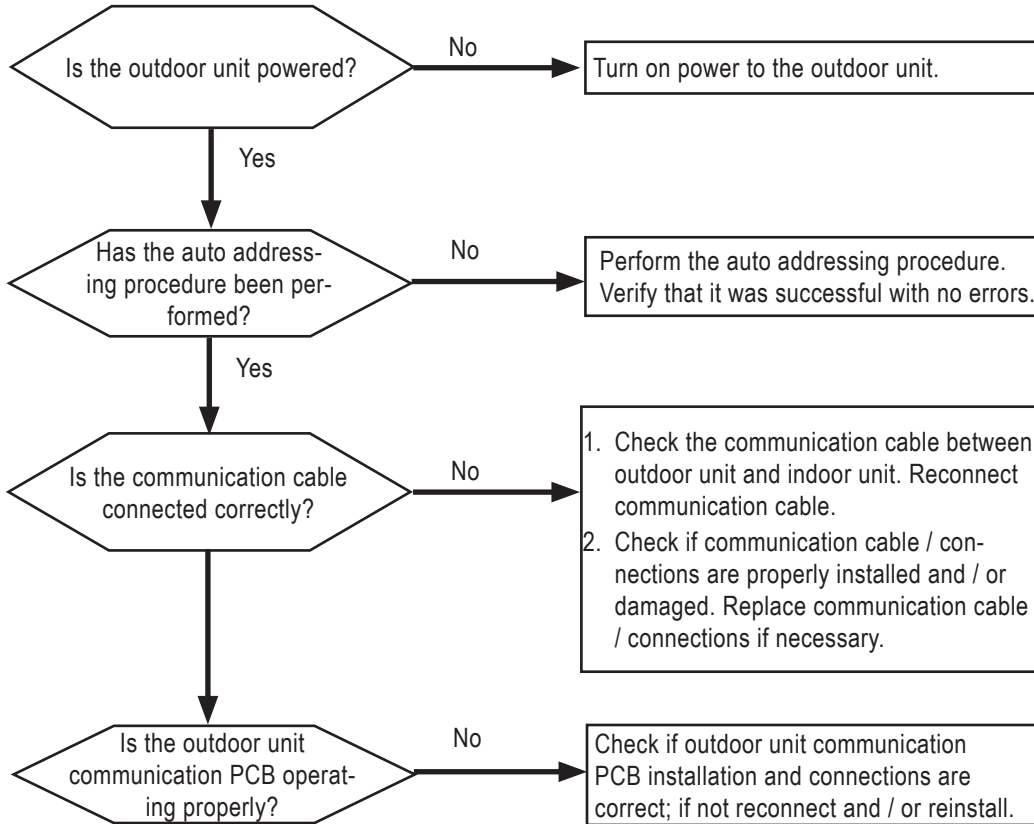

Note:

See also Error Code No. 05: Indoor Unit PCB Communication Error between Outdoor Unit and Indoor Unit, and Error Code No. 237: RS-485 Communication Error Between Indoor Unit and Outdoor Unit.



Please refer to the Safety Precautions on pages 4-7 for more detail to prevent injury or death regarding the operation and service troubleshooting of the Multi V product.

Error No.	Description	Details	Causes
242	Network error.	Network error of central controller.	<ol style="list-style-type: none"> 1. RS-485 communication wiring defect. 2. Communication defect between remote controller and indoor unit. 3. RS-485 DIP switch setting error 4. Indoor unit addressing setting error on central controller

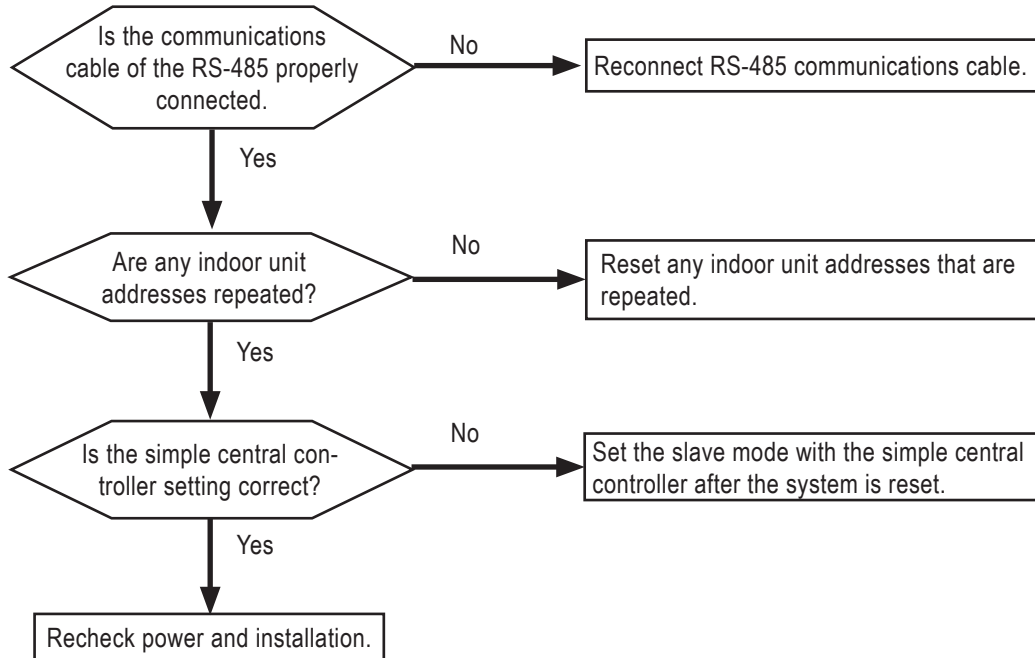

Communications LED Between the Network and the Outdoor Unit
(The communications LED flashes on and off when communication is normal between the network and the outdoor unit.)

Incorrect RS-485 Communication Wiring

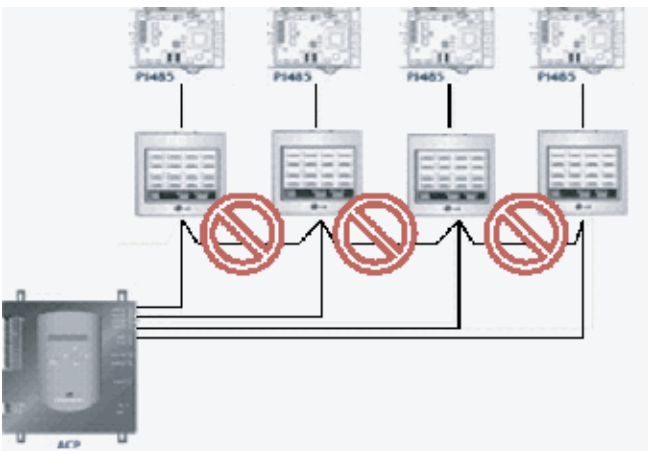

Note:

Images here are representative of system components. Actual component appearance depends on model and system type.

REPLACING THE INVERTER PCB HEAT SINK

MULTI V[™]S

Replacing the Inverter PCB Heat Sink

If the inverter PCB is replaced at any time, the heat sink must be replaced.

⚠ WARNING

If there isn't any heat sink paste, or isn't a sufficient amount of heat sink paste, between the inverter PCB and the outdoor unit heat sink plate, the unit will overheat, causing a fire, physical injury, or death.

Note:

If there isn't any heat sink paste, or isn't a sufficient amount of heat sink paste, between the inverter PCB and the outdoor unit heat sink plate, the unit will overheat and damage the PCB and outdoor unit.

1. Remove inverter PCB by detaching its screws using a JIS screwdriver.

Note:

Only use a JIS screwdriver. A standard Phillips screwdriver will damage / strip the inverter PCB screw heads.

2. Wipe off any existing heat sink paste material from the inverter PCB heat sink plate, as well as from the outdoor unit heat sink plate. Gently scrape off as much heat sink paste material as possible, taking care not to damage the back of the inverter PCB or the outdoor unit heat sink plate.
3. Evenly apply a coating of silicone-based electronic heat sink paste to the inverter PCB heat plate. Verify all applicable areas of the PCB heat plate are completely covered. ⚠ Do not let foreign matter settle onto the heat sink paste.
4. Reinstall the inverter PCB by reattaching its screws a JIS screwdriver. Tighten the screws, but ⚠ do not overtighten.

Checking the Inverter Compressor Phase Diode Bridge

1. Shut off main power. After main power is shut off, wait at least ten (10) minutes until inverter compressor PCB DC voltage is discharged.

Figure 71: Simplified Diagram of a Phase Diode Bridge.

⚠ WARNING

After switching off the main power supply and verifying that the DC voltage was discharged, wait for at least ten (10) minutes before checking the electrical components in the control box. There is risk of electric shock, physical injury or death.

2. Disconnect all connections to the phase diode bridge.
3. Set the multi-tester to diode mode.
4. Measured value must be 0.4V ~ 0.7V as shown in table below.
5. If the measured value is different than what is listed in the table below, set the multi-tester to resistance mode and measure again. If the value is too low (0Ω) or too high (hundreds MΩ), the inverter PCB needs to be replaced.
6. If the diode bridge is damaged, check if the inverter PCB assembly (IPM) also needs to be replaced.

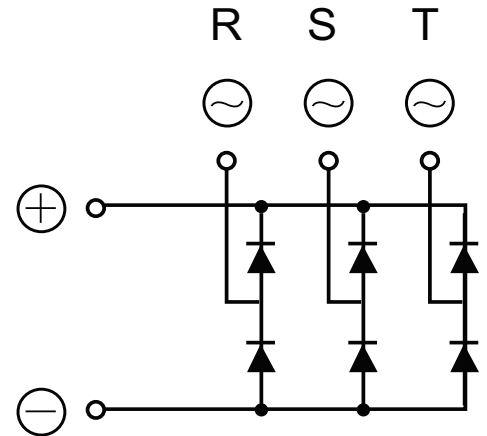

Table 62: Checking the Phase Diode Bridge.

Tester Terminal \ Diode Terminal	+ Terminal: black (-)	- Terminal: red (+)
R (~) : Red (+)	0.4V ~ 0.7V	-
S (~) : Red (+)	0.4V ~ 0.7V	-
T (~) : Red (+)	0.4V ~ 0.7V	-
R (~) : Black (-)	-	0.4V ~ 0.7V
S (~) : Black (-)	-	0.4V ~ 0.7V
T (~) : Black (-)	-	0.4V ~ 0.7V

Red (+) and Black (-) are the multi-tester terminals.

CHECKING INPUT VOLTAGE IN CASE OF POWER ON



WARNING Please refer to the Safety Precautions on pages 4-7 for more detail to prevent injury or death regarding the operation and service troubleshooting of the Multi V product.

Checking Input Voltage (One Phase / Two Wire)

Figure 72: Checking Converter DC Link Voltage.

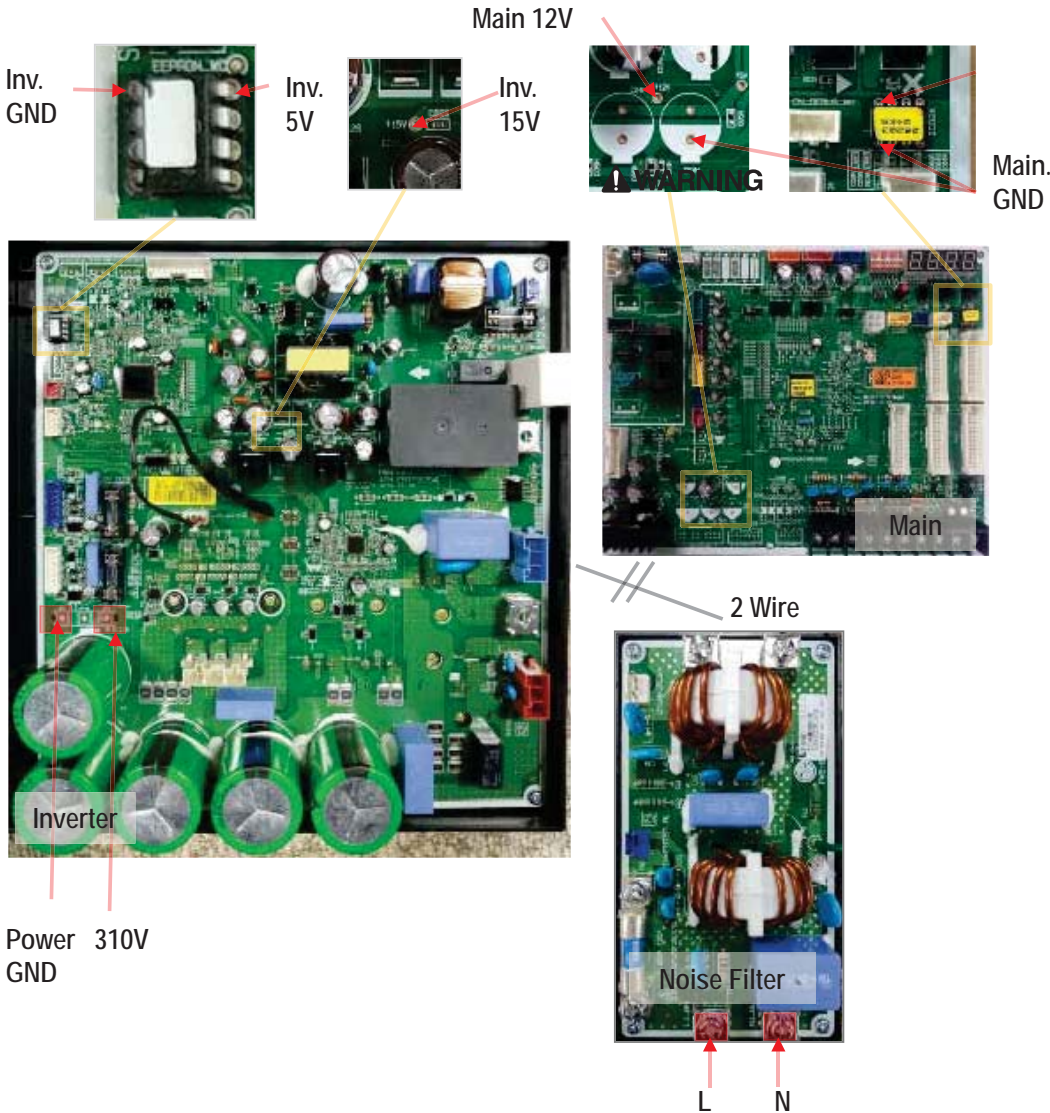
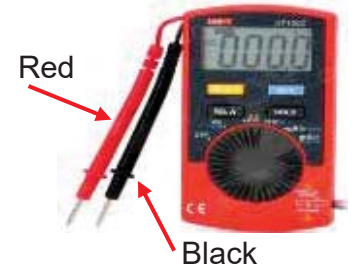

Figure 73: Multi-Meter (Note the Probe Color).



Note:

Images here are representative of system components. Actual component appearance depends on model and system type.

Table 63: Input Voltage Measurements.

Check	Mode	Multi-Meter		Measured Value	
		Black	Red	Normal	Abnormal
Input Voltage (1-Phase / 2-Wire 220V)	AC	N	L	220V ± 15%	Not Normal
DC Voltage	DC	Inv. GND	5V	4.5V ~ 5.5V	4V ↓
			15V	14.5V ~ 15.5V	14V ↓
		Main GND	5V	4.5V ~ 5.5V	4V ↓
			12V	11.5V ~ 12.5V	11V ↓
		310V	Power GND	310V	310V ± 20%

CHECKING ODU TO ODU COMM. (DC VOLTAGE) IN CASE OF POWER ON

⚠ WARNING Please refer to the Safety Precautions on pages 4-7 for more detail to prevent injury or death regarding the operation and service troubleshooting of the Multi V product.

Figure 74: Checking ODU to ODU Communications (DC Voltage).

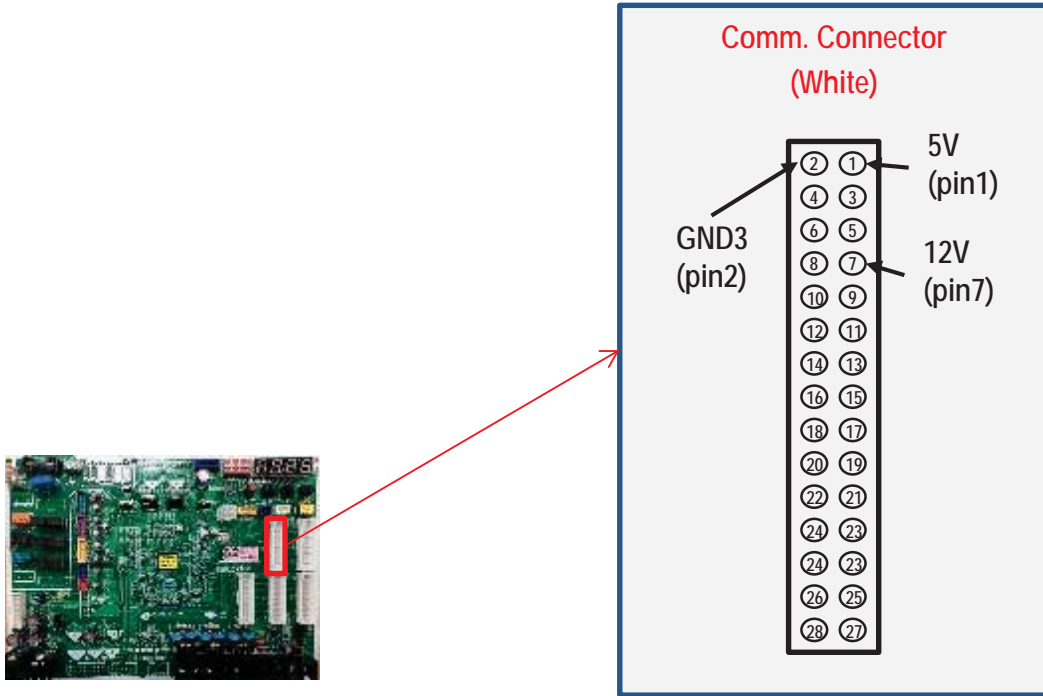
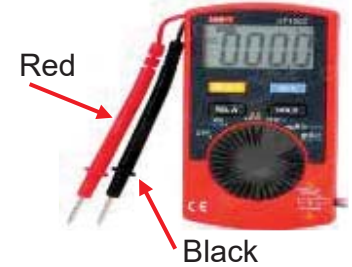

Figure 75: Multi-Meter (Note the Probe Color).



Note:
Images here are representative of system components. Actual component appearance depends on model and system type.

Table 64: ODU to ODU Communications (DC Voltage) Measurements.

Check	Mode	Multi-Meter		Measured Value	
		Black	Red	Normal	Abnormal
Main (DC-Comm.)	DC	GND3 (pin2)	5V (pin1)	4.5V~5.5V	4V↓

CHECKING INVERTER PCB IN CASE OF POWER OFF

WARNING Please refer to the Safety Precautions on pages 4-7 for more detail to prevent injury or death regarding the operation and service troubleshooting of the Multi V product.

Figure 76: Checking Inverter PCB.

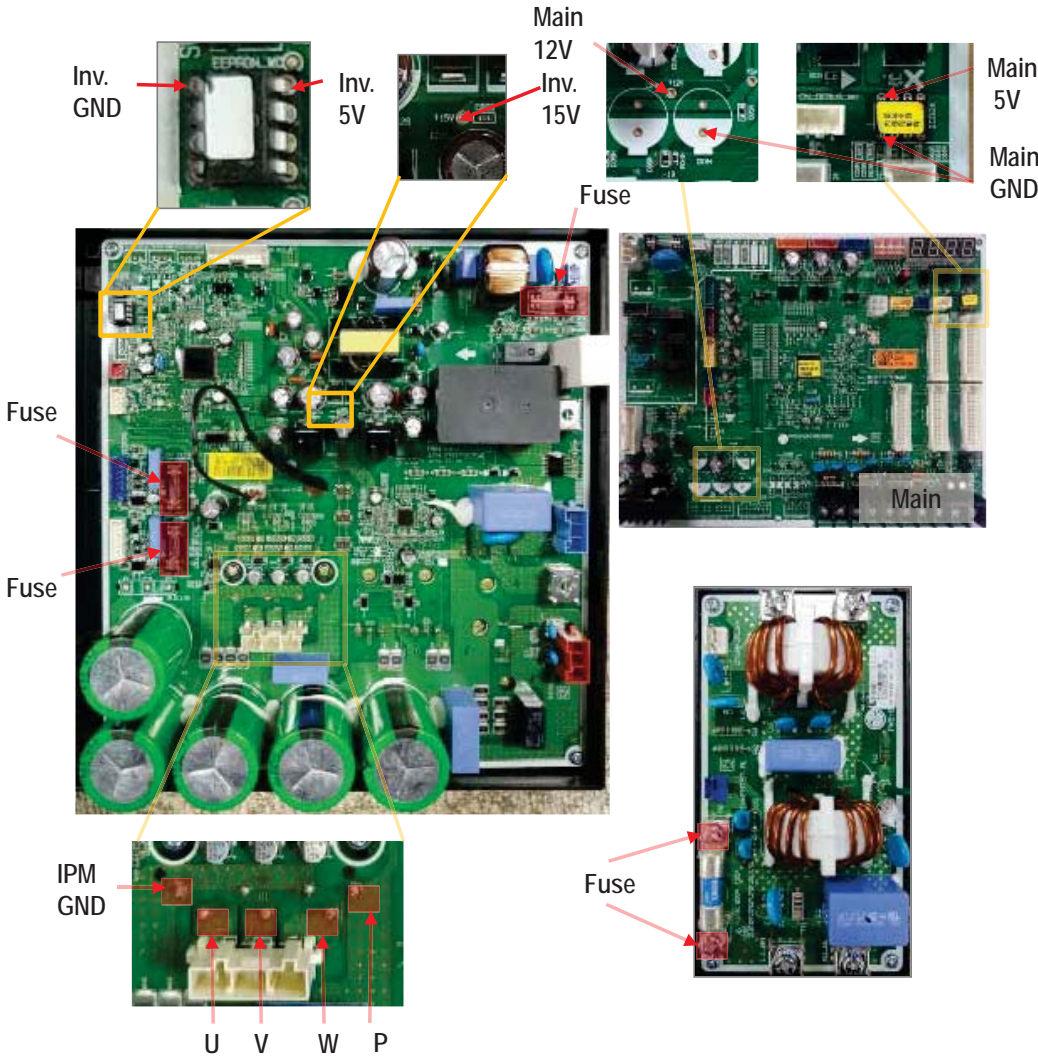

Figure 77: Multi-Meter (Note the Probe Color).



Note:
Images here are representative of system components. Actual component appearance depends on model and system type.

Table 65: Inverter PCB Measurements.

Check	Mode	Multi-Meter		Measured Value	
		Black	Red	Normal	Abnormal
Fuse		Both sides		Short	Open
5V part Resistance	Ω	Main / Inv. GND	Main / Inv. 5V	$1k\Omega \uparrow$	$1k\Omega \downarrow \sim 0\Omega$
15V part Resistance	Ω	Main / Inv. GND	Main / Inv. 15V	$100\Omega \uparrow$	$100\Omega \downarrow \sim 0\Omega$
IPM		P	U	0.35V ~ 0.7 V	Not Normal
			V		
			W		
		U	IPM GND		
		V			
W					

CHECKING INVERTER PCB IN CASE OF POWER OFF

⚠ WARNING Please refer to the Safety Precautions on pages 4-7 for more detail to prevent injury or death regarding the operation and service troubleshooting of the Multi V product.

Figure 78: Checking Inverter PCB.

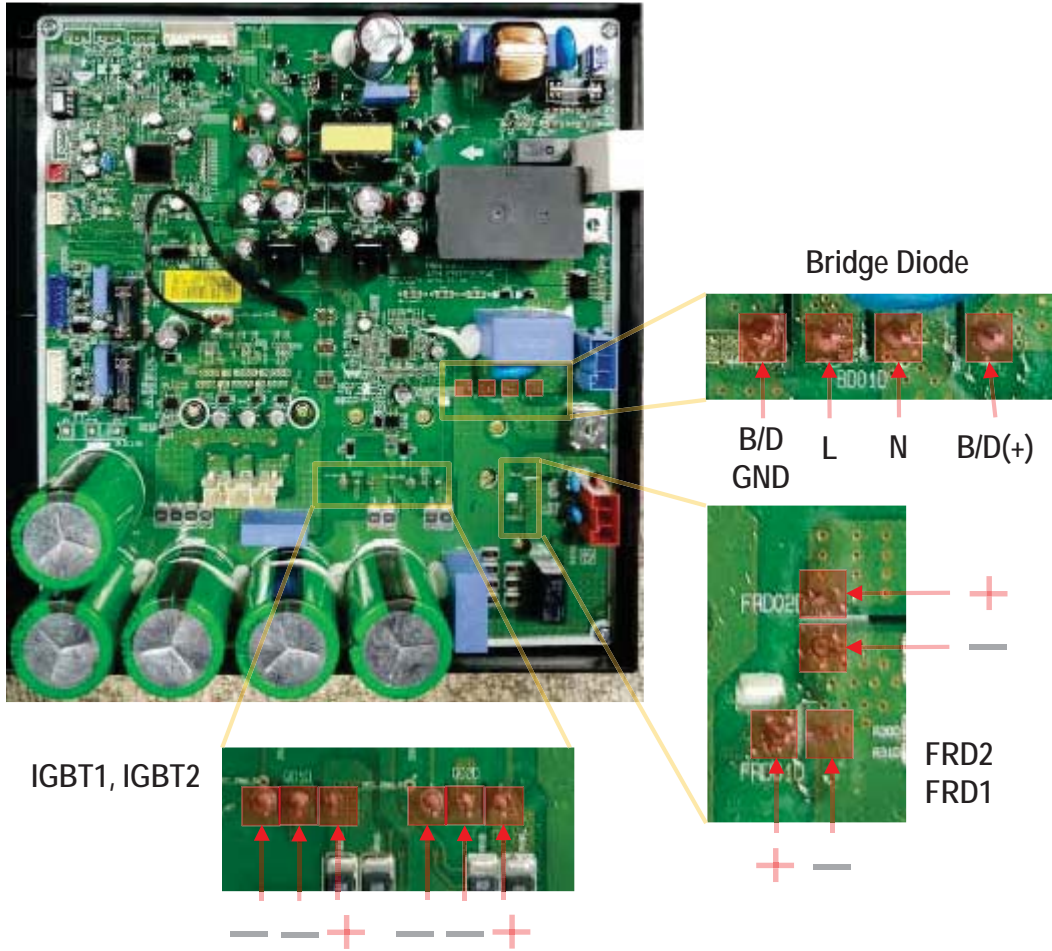
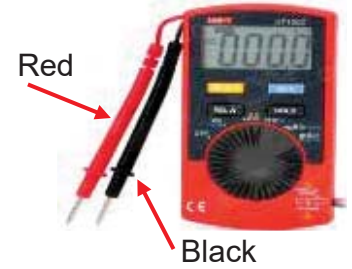

Figure 79: Multi-Meter (Note the Probe Color).



Note:
Images here are representative of system components. Actual component appearance depends on model and system type.

Table 66: Inverter PCB Measurements.

Check	Mode	Multi-Meter		Measured Value	
		Black	Red	Normal	Abnormal
Fuse		Both sides		Short	Open
5V part Resistance	Ω	Main / Inv. GND	Main / Inv. 5V	1k Ω ↑	1k Ω ↓ ~ 0 Ω
15V part Resistance	Ω	Main / Inv. GND	Main / Inv. 15V	100 Ω ↑	100 Ω ↓ ~ 0 Ω
Bridge Diode		B/D (+)	L	0.35V ~ 0.7V	Not Normal
		L	N		
		N	B/D GND		
FRD		-	+		
IGBT		-	+		

CHECKING INVERTER PCB IN CASE OF POWER OFF

⚠ WARNING Please refer to the Safety Precautions on pages 4-7 for more detail to prevent injury or death regarding the operation and service troubleshooting of the Multi V product.

Figure 80: Checking Inverter PCB.

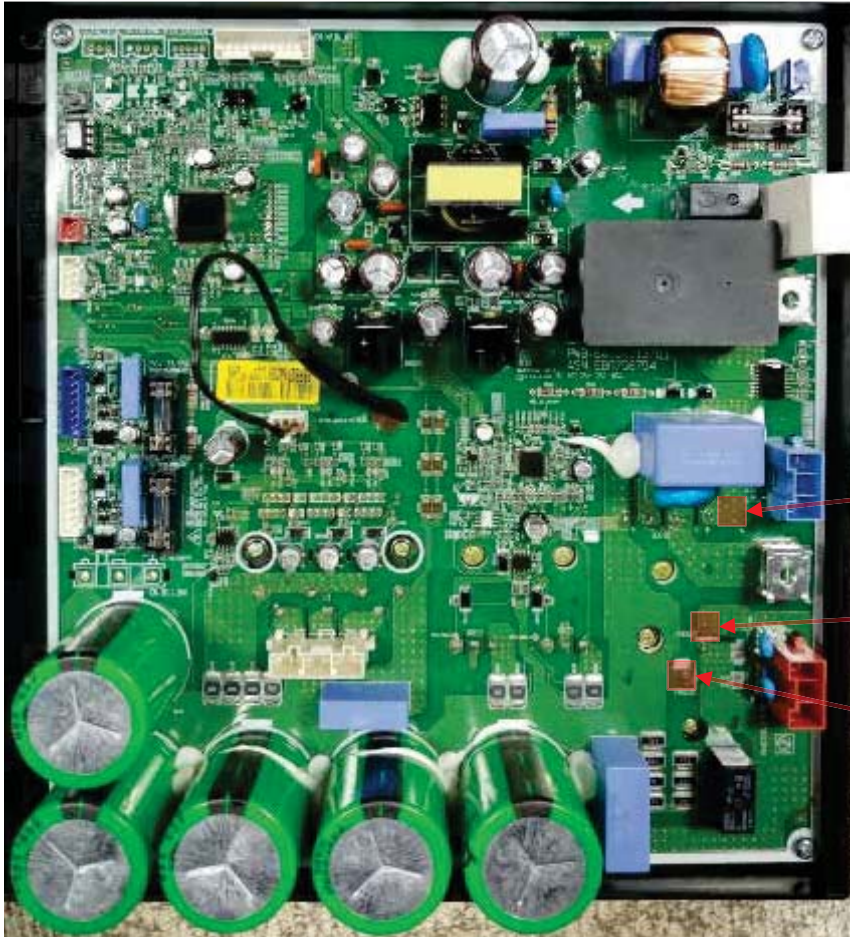

Reactor (Input)

Reactor (Output2)

Reactor (Output1)

Figure 81: Multi-Meter (Note the Probe Color).

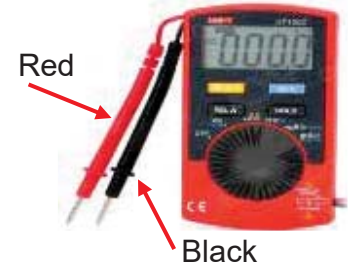

Red

Black

Note:

Images here are representative of system components. Actual component appearance depends on model and system type.

Table 67: Inverter PCB Measurements.

Check	Mode	Multi-Meter		Measured Value	
		Black	Red	Normal	Abnormal
Reactor)))	Output1	Input	Short	Open (Not Normal)
		Output2			

CHECKING MAIN PCB IN CASE OF POWER OFF

⚠ WARNING Please refer to the Safety Precautions on pages 4-7 for more detail to prevent injury or death regarding the operation and service troubleshooting of the Multi V product.

Figure 82: Checking Main PCB (Communication IC).



Figure 83: Multi-Meter (Note the Probe Color).

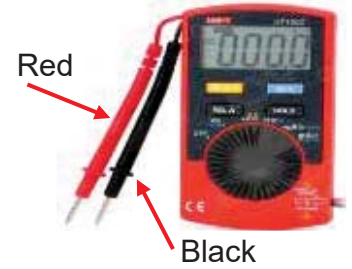

Table 68: Main PCB (Communication IC) Measurements.

Check	Mode	Multi-Meter		Measured Value	
		Black	Red	Normal	Abnormal
IC26D	Ω	IC26D GND (pin 5)	IC26D Vcc (pin 8)	1kΩ↑	Not Normal

Note:

Images here are representative of system components. Actual component appearance depends on model and system type.

PCB LOCATIONS

⚠ WARNING Please refer to the Safety Precautions on pages 4-7 for more detail to prevent injury or death regarding the operation and service troubleshooting of the Multi V product.

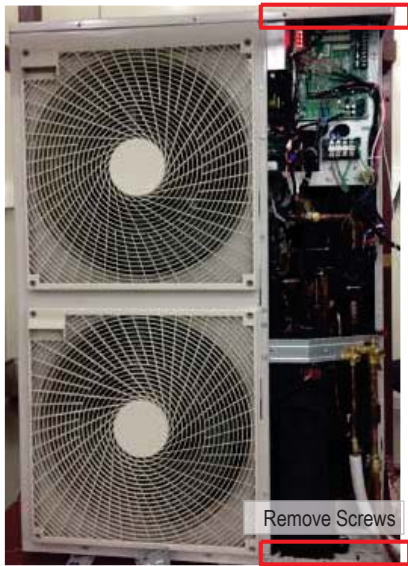

Control Box - Front

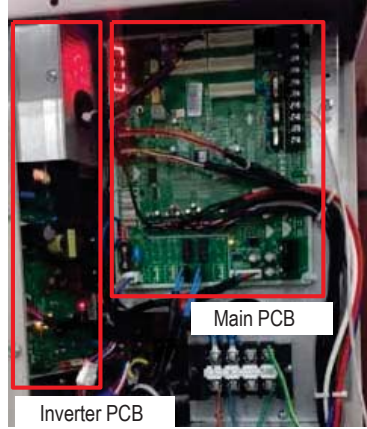

Control Box - Back

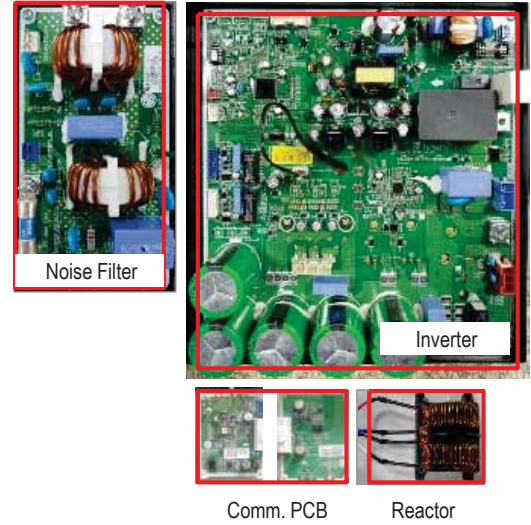

1. Remove outdoor unit front panel screws.
2. Remove outdoor unit front panel.
 - Check Main PCB
 - Remove T/B R,S,T,N screws
 - Disconnect Main PCB connector
 - Remove control box front panel screws
 - Remove control box front panel
 - Check N/F, Inverter PCB

Outdoor Unit PCBs - Front of Control Box



Main PCB



Inverter PCB

Outdoor Unit PCBs - Back of Control Box



Noise Filter



IDU to ODU
Comm. PCB



Gen. to ODU
Comm. PCB

Main PCB for ARUN024 to 053GSS4 Heat Pump Outdoor Units

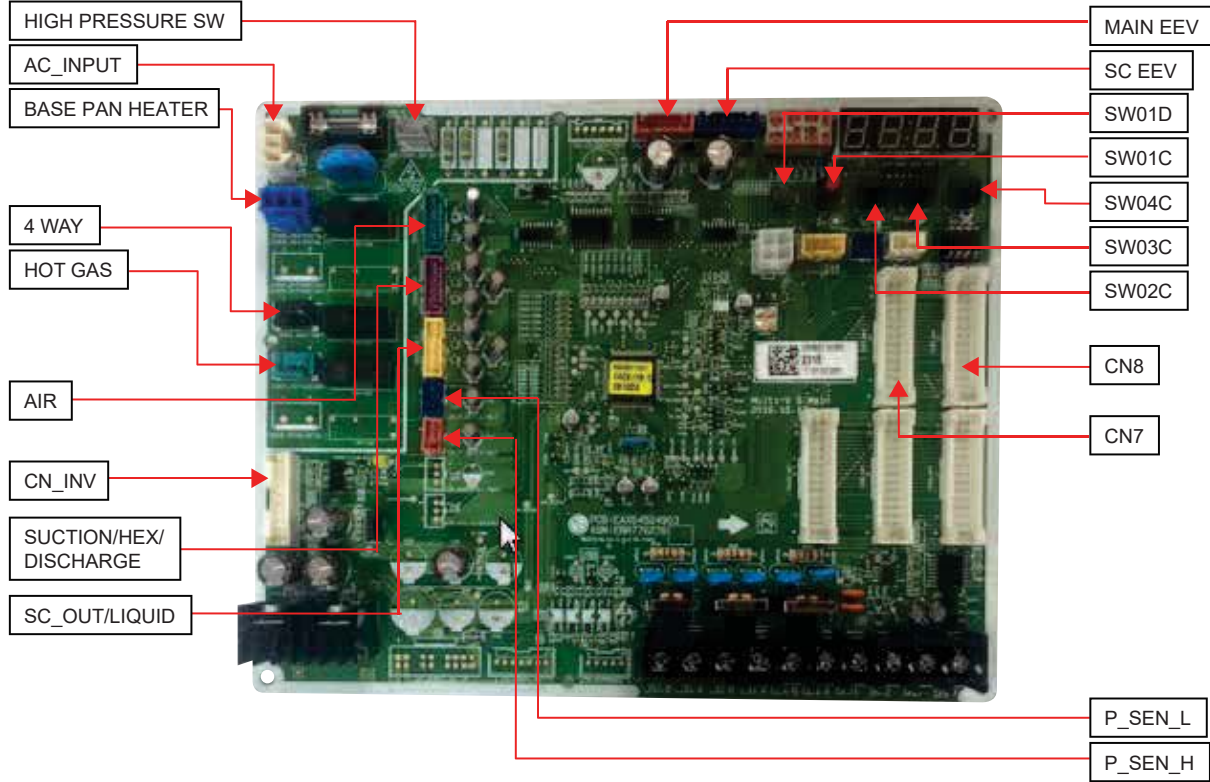

Parts

Main PCB for ARUN060GSS4 Heat Pump and ARUB060GSS4 Heat Recovery Outdoor Units

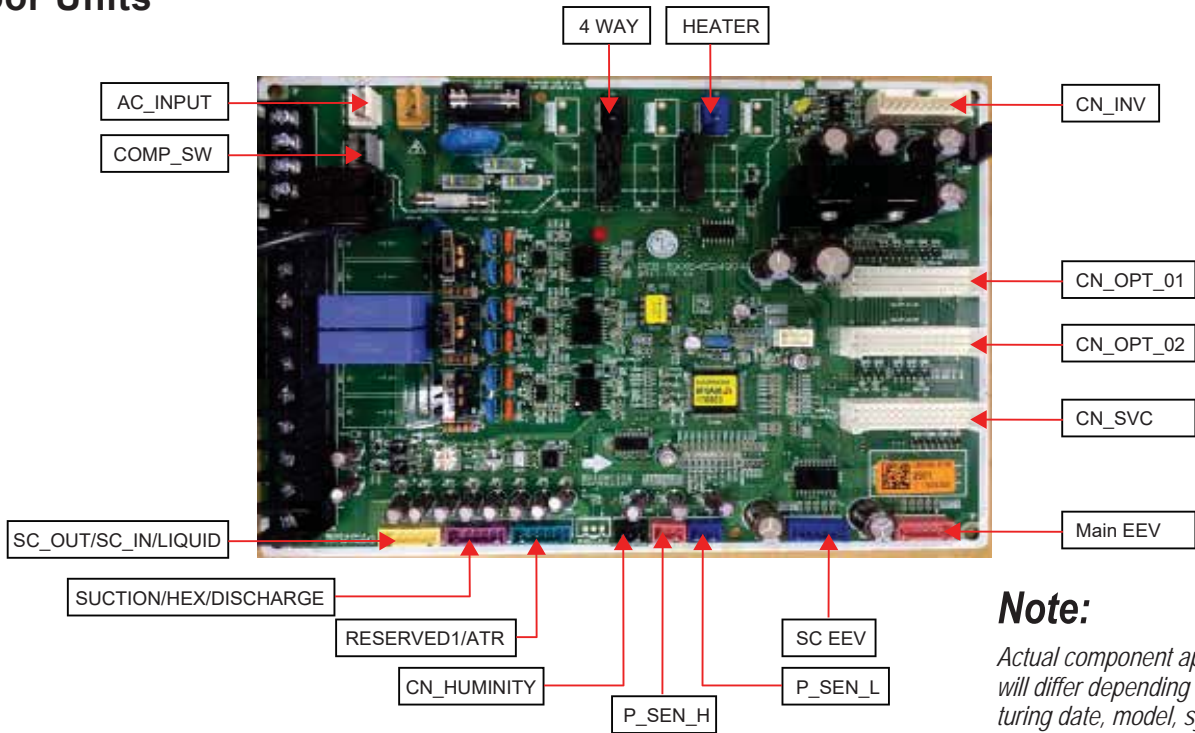

Note:

Actual component appearances will differ depending on manufacturing date, model, system type, etc.

OUTDOOR UNIT PARTS

PCBs

PI-485 PCB for ARUN024 to 053GSS4 Heat Pump Outdoor Units



Indoor Communications PCB for ARUN024 to 053GSS4 Heat Pump Outdoor Units



Noise Filter PCB for ARUN024 to 053GSS4 Heat Pump Outdoor Units



To Main PCB
220V Power Output
Terminal

To Inverter PCB
220V Power Output
Terminal

Inverter PCB for ARUN024 to 053GSS4 Heat Pump Outdoor Units

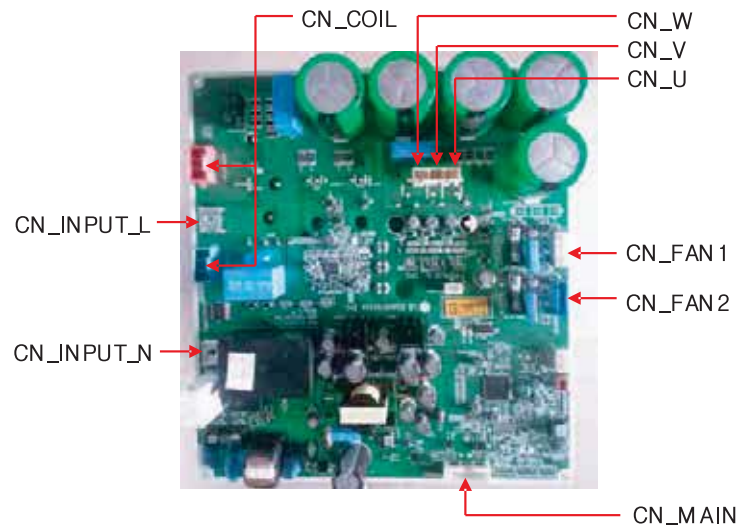

Note:

Actual component appearances will differ depending on manufacturing date, model, system type, etc.

Note:

The fuse is not replaceable.

**Indoor Communications PCB
ARUN060GSS4 Heat Pump and
ARUB060GSS4 Heat Recovery
Outdoor Units**



**Service PCB ARUN060GSS4 Heat
Pump and ARUB060GSS4 Heat
Recovery Outdoor Units**



**Noise Filter for ARUN060GSS4 Heat
Pump and ARUB060GSS4 Heat
Recovery Outdoor Units**

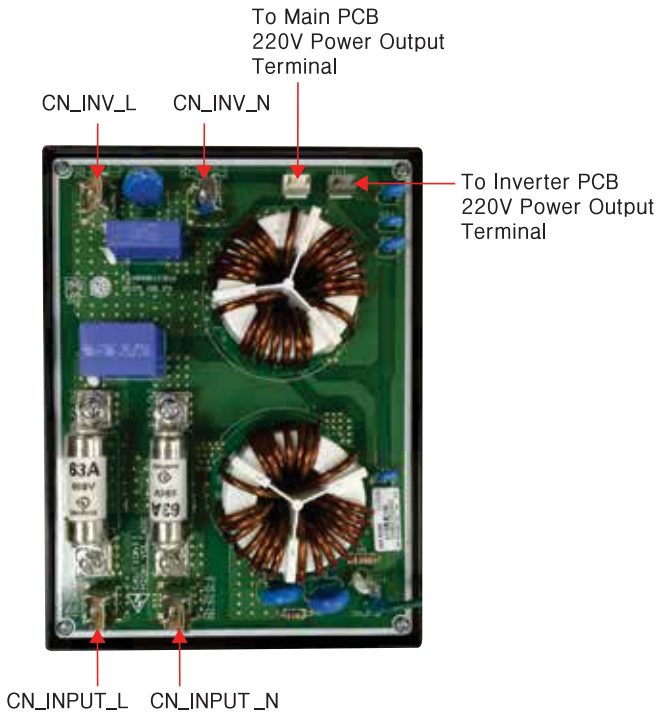

**Inverter PCB for ARUN060GSS4 Heat
Pump and ARUB060GSS4 Heat
Recovery Outdoor Units**

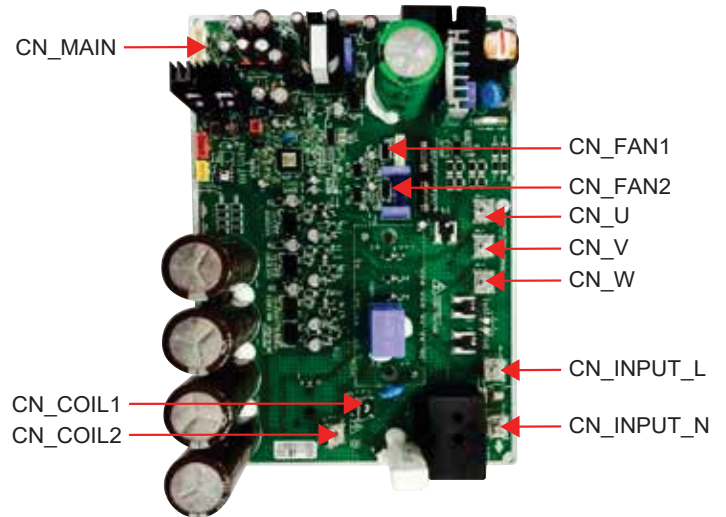

Note:
Actual component appearances will differ depending on manufacturing date, model, system type, etc.

Note:
The Danifuse is a TDR fuse; changed from the Bussman.

OUTDOOR UNIT PARTS



Control Box Parts

Control Box Parts for ARUN24GSS4 Heat Pump Outdoor Units

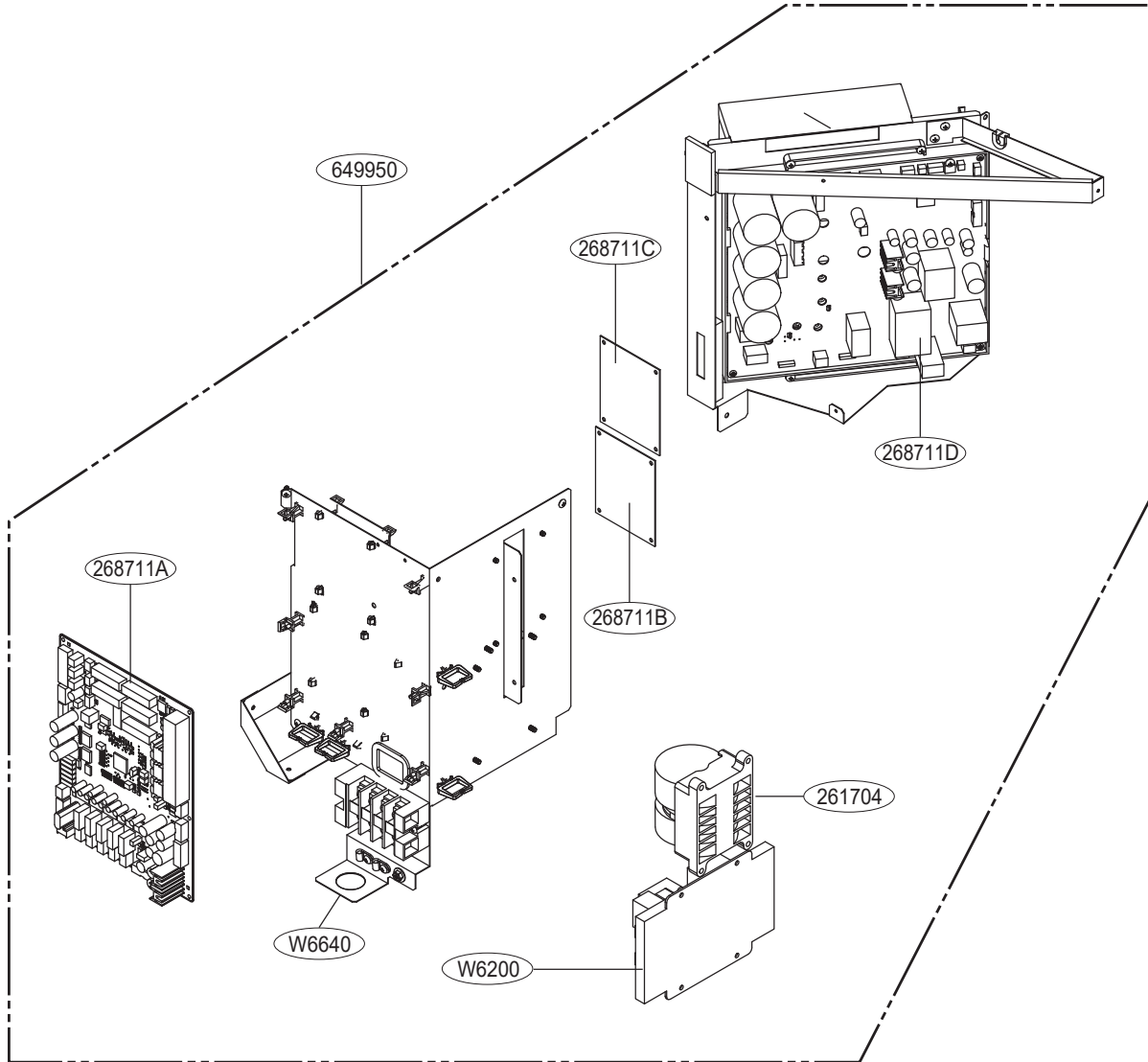

Table 69: Control Box Parts for ARUN24GSS4 Heat Pump Outdoor Units.

Part No.	Description	Color
263230A	Subcooling Out Pipe + Liquid Pipe	Yellow
263230B	Suction Pipe + Heat Exchanger + Discharge Pipe	Purple
263230C	Air Temperature Sensor	Green

Note:

Actual component appearances will differ depending on manufacturing date, model, system type, etc.

Control Box Parts for ARUN38 to 53GSS4 Heat Pump Outdoor Units

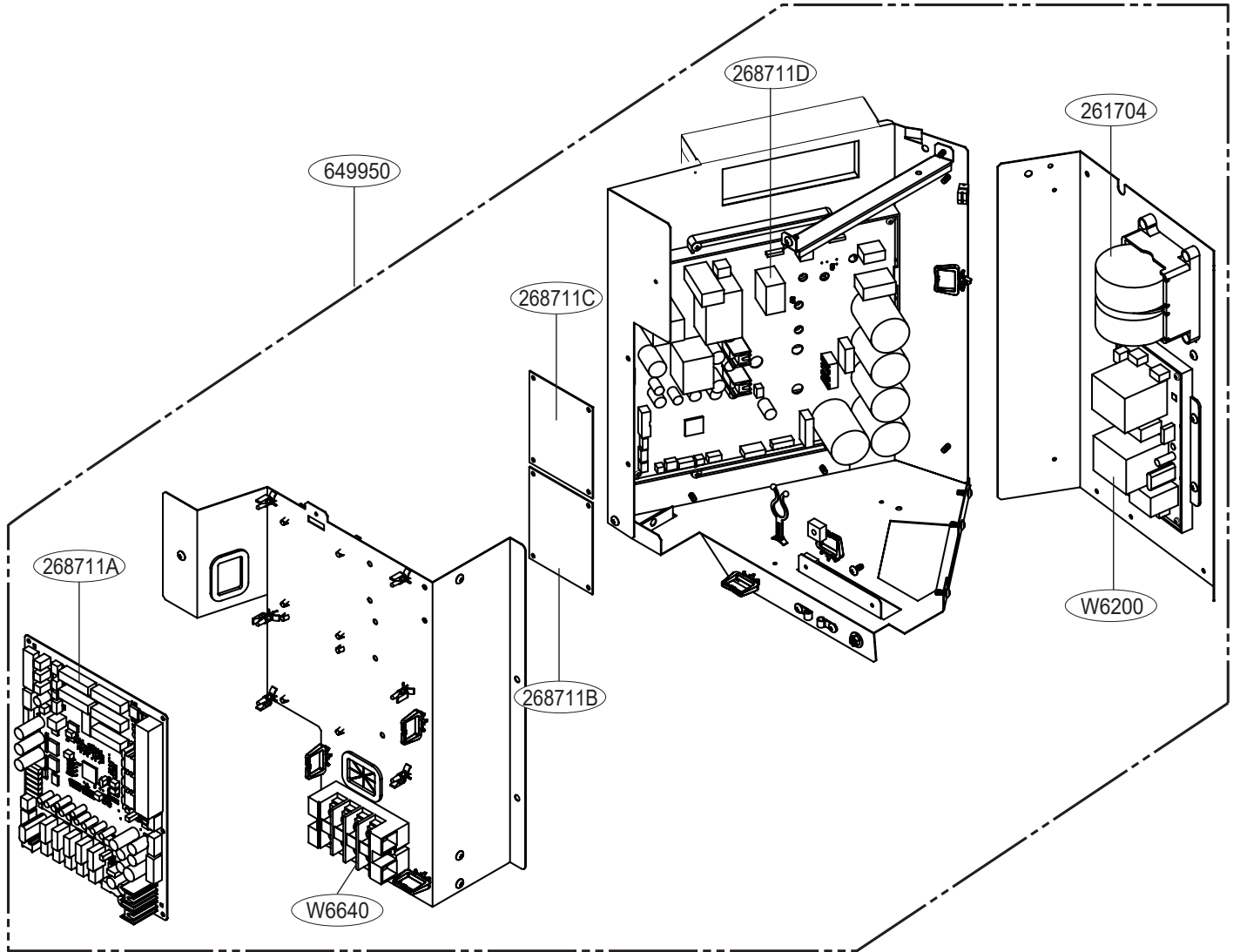

Parts

Table 70: Control Box Parts for ARUN38 to 53GSS4 Heat Pump Outdoor Units.

Part No.	Description	Color
263230A	Subcooling Out Pipe + Liquid Pipe	Yellow
263230B	Suction Pipe + Heat Exchanger + Discharge Pipe	Purple
263230C	Air Temperature Sensor	Green

Note:

Actual component appearances will differ depending on manufacturing date, model, system type, etc.

OUTDOOR UNIT PARTS



Control Box Parts

Control Box Parts for ARUN060GSS4 Heat Pump and ARUB060GSS4 Heat Recovery Outdoor Units

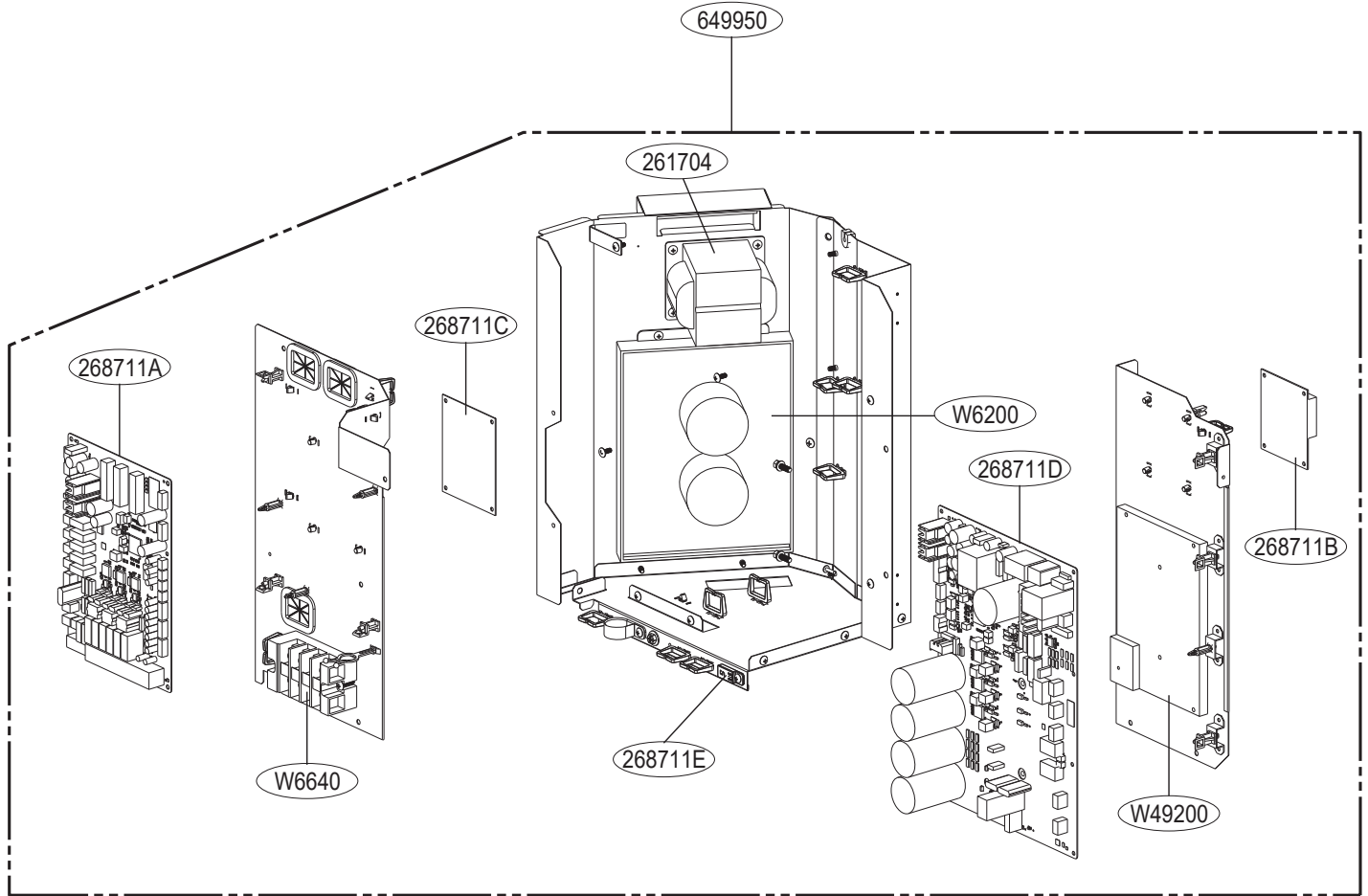

MULTI V S Outdoor Unit Service Manual

Table 71: Control Box Parts for ARUN60GSS4 Heat Pump and ARUN60GSS4 Heat Recovery Outdoor Units.

Part No.	Description	Color
263230A	Subcooling Out Pipe + Liquid Pipe	Yellow
263230B	Suction Pipe + Heat Exchanger + Discharge Pipe	Purple
263230C	Air Temperature Sensor	Green

Note:

Actual component appearances will differ depending on manufacturing date, model, system type, etc.



Expanded Frame View for ARUN24GSS4 Heat Pump Outdoor Units

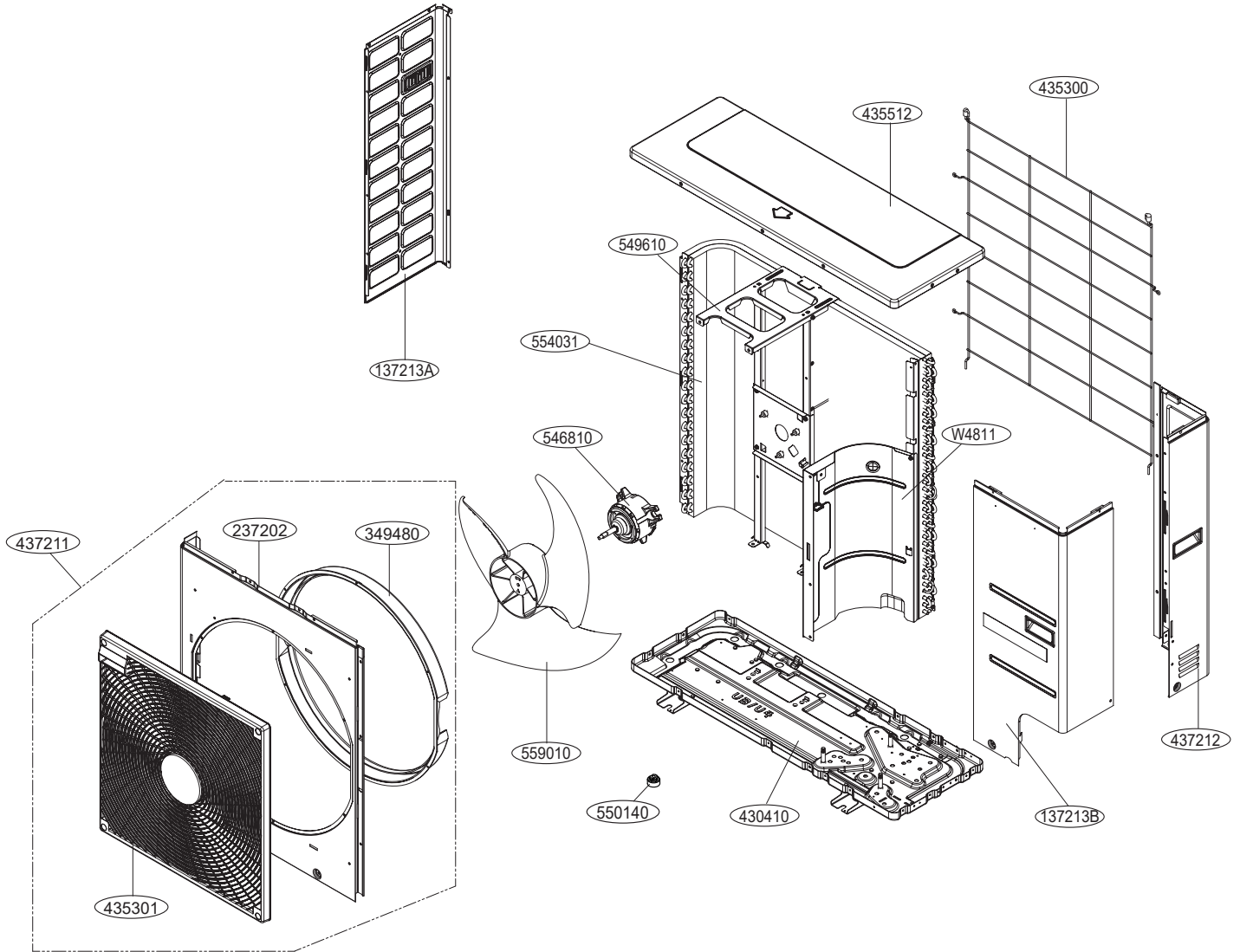

Parts

Note:

Actual component appearances will differ depending on manufacturing date, model, system type, etc.

OUTDOOR UNIT PARTS

MULTI V[™]S

Expanded Frame View

Expanded Frame View for ARUN38 to 53GSS4 Heat Pump Outdoor Units

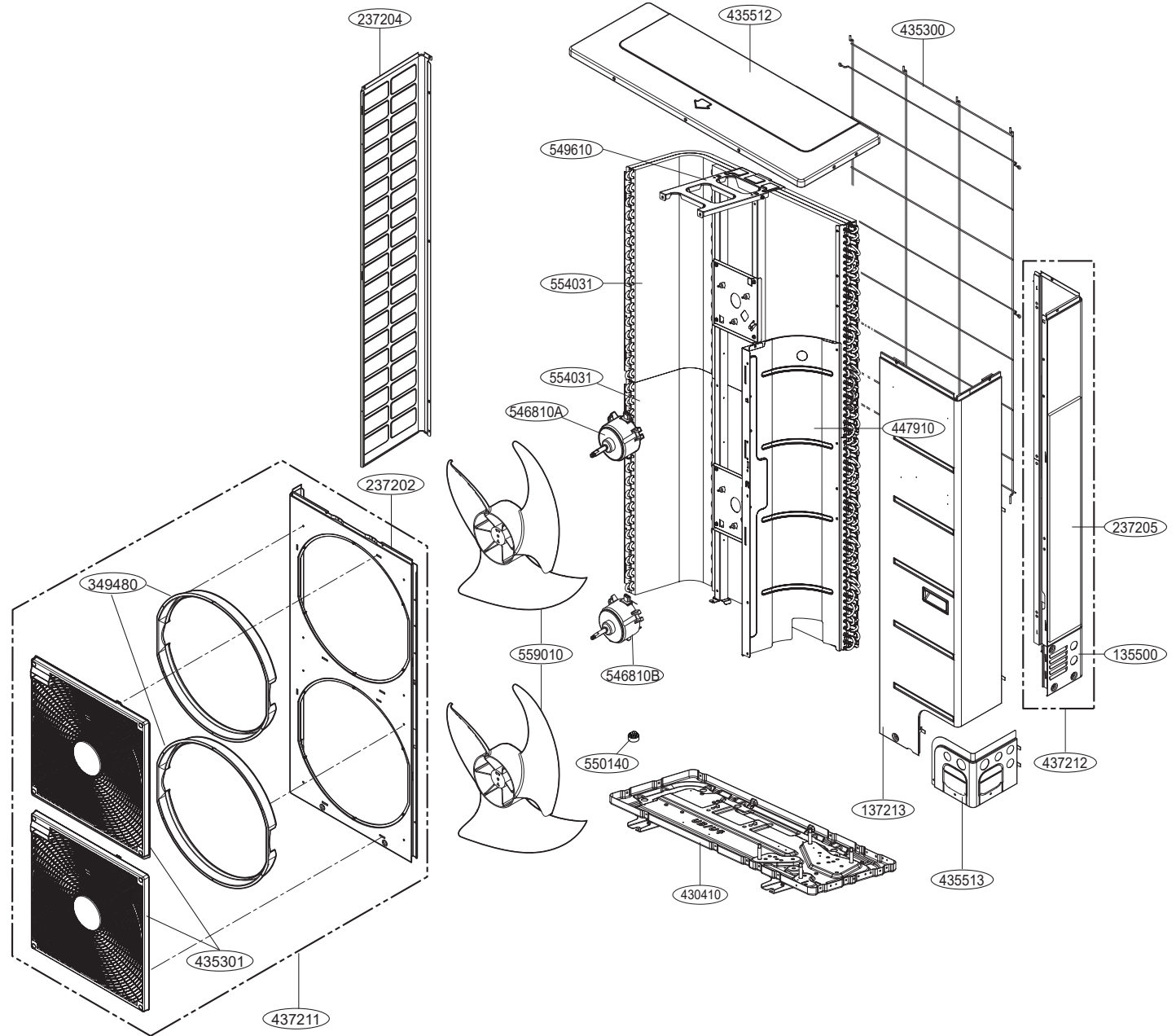

Note:

Actual component appearances will differ depending on manufacturing date, model, system type, etc.

Expanded Frame View for ARUN060GSS4 Heat Pump and ARUB060GSS4 Heat Recovery Outdoor Units

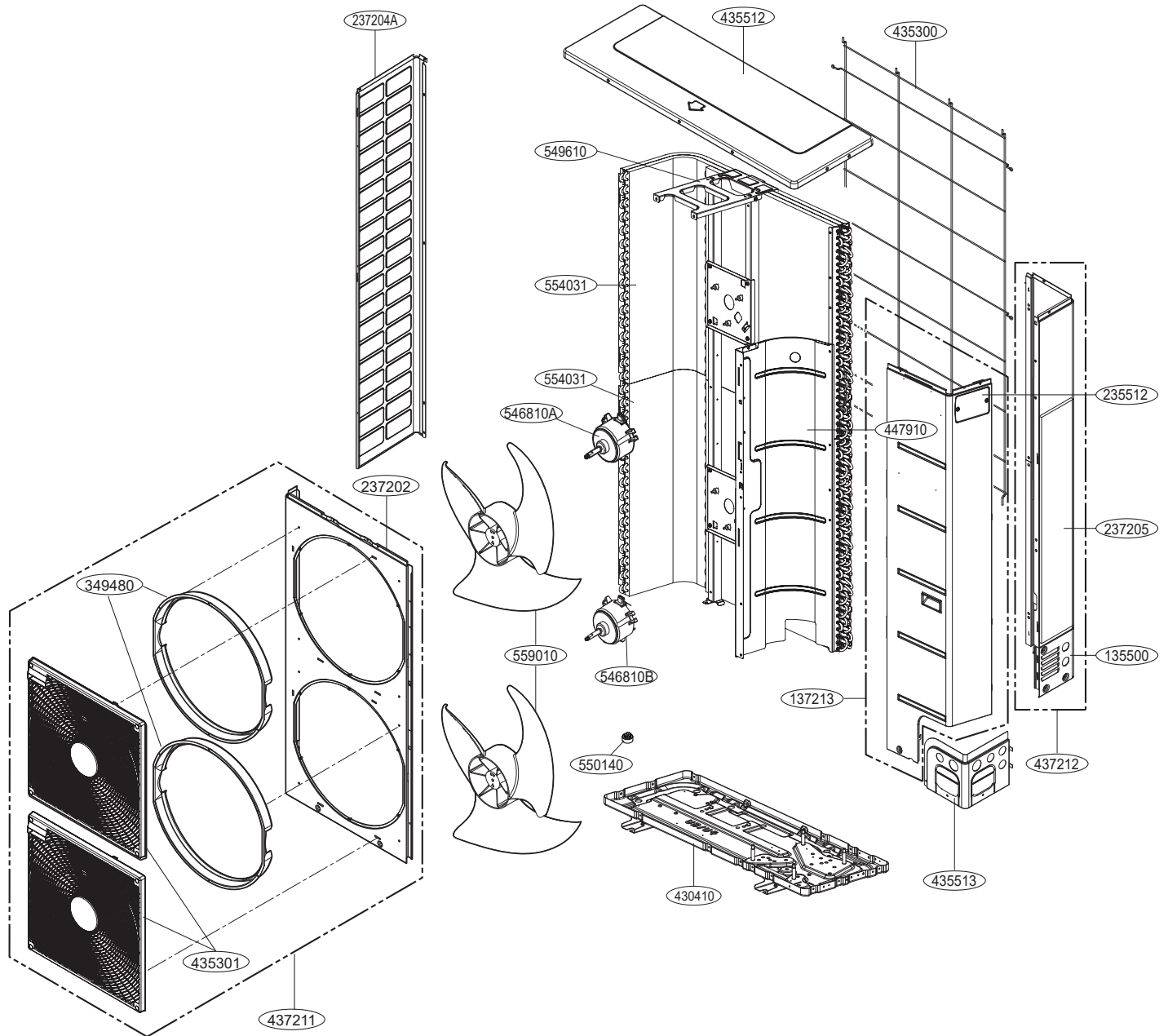

Parts

Note:

Actual component appearances will differ depending on manufacturing date, model, system type, etc.

OUTDOOR UNIT PARTS



Expanded Piping View

Expanded Piping View for ARUN24GSS4 Heat Pump Outdoor Units

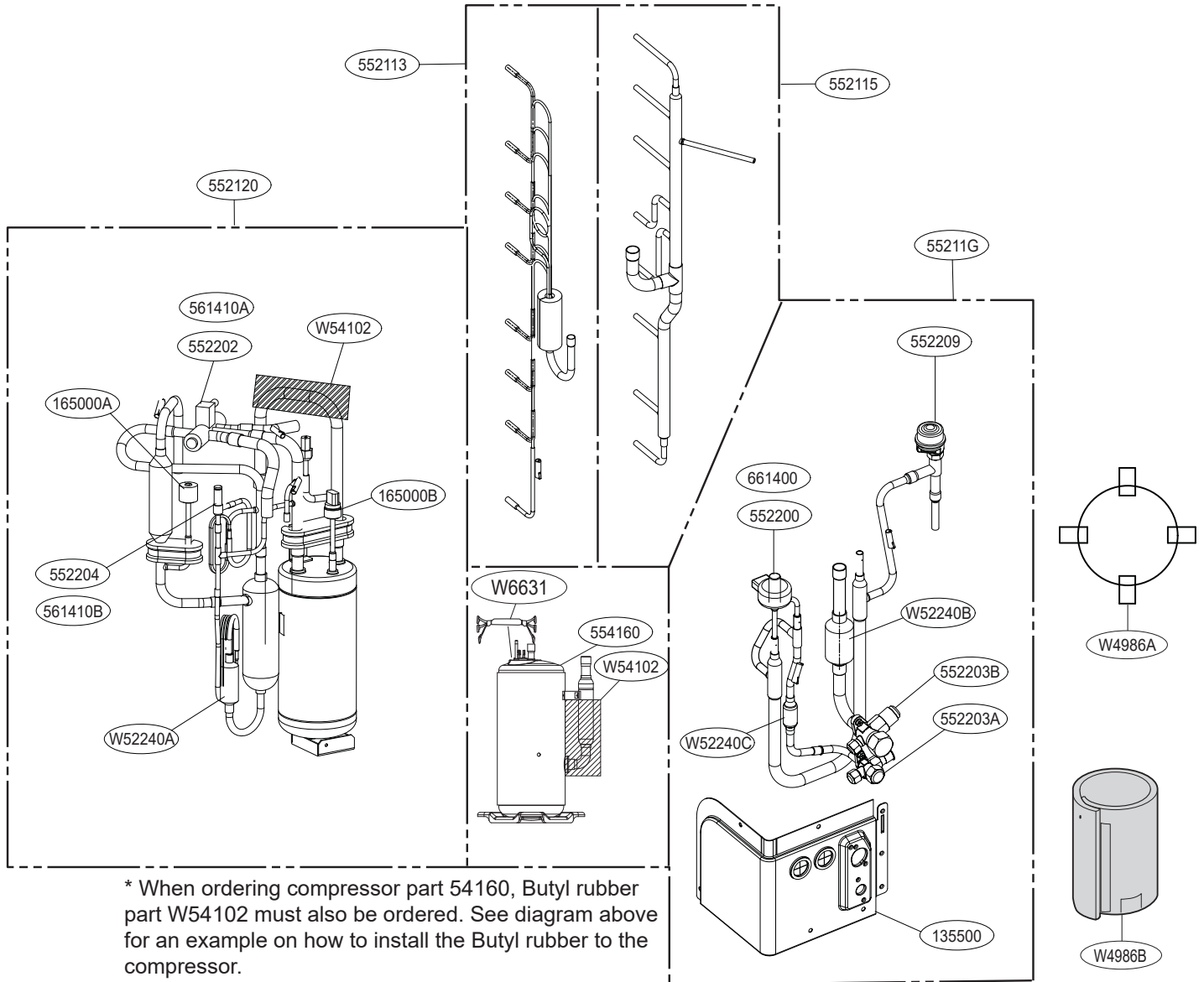

MULTI V S Outdoor Unit Service Manual

Note:

Actual component appearances will differ depending on manufacturing date, model, system type, etc.



Expanded Piping View for ARUN38 to 53GSS4 Heat Pump Outdoor Units

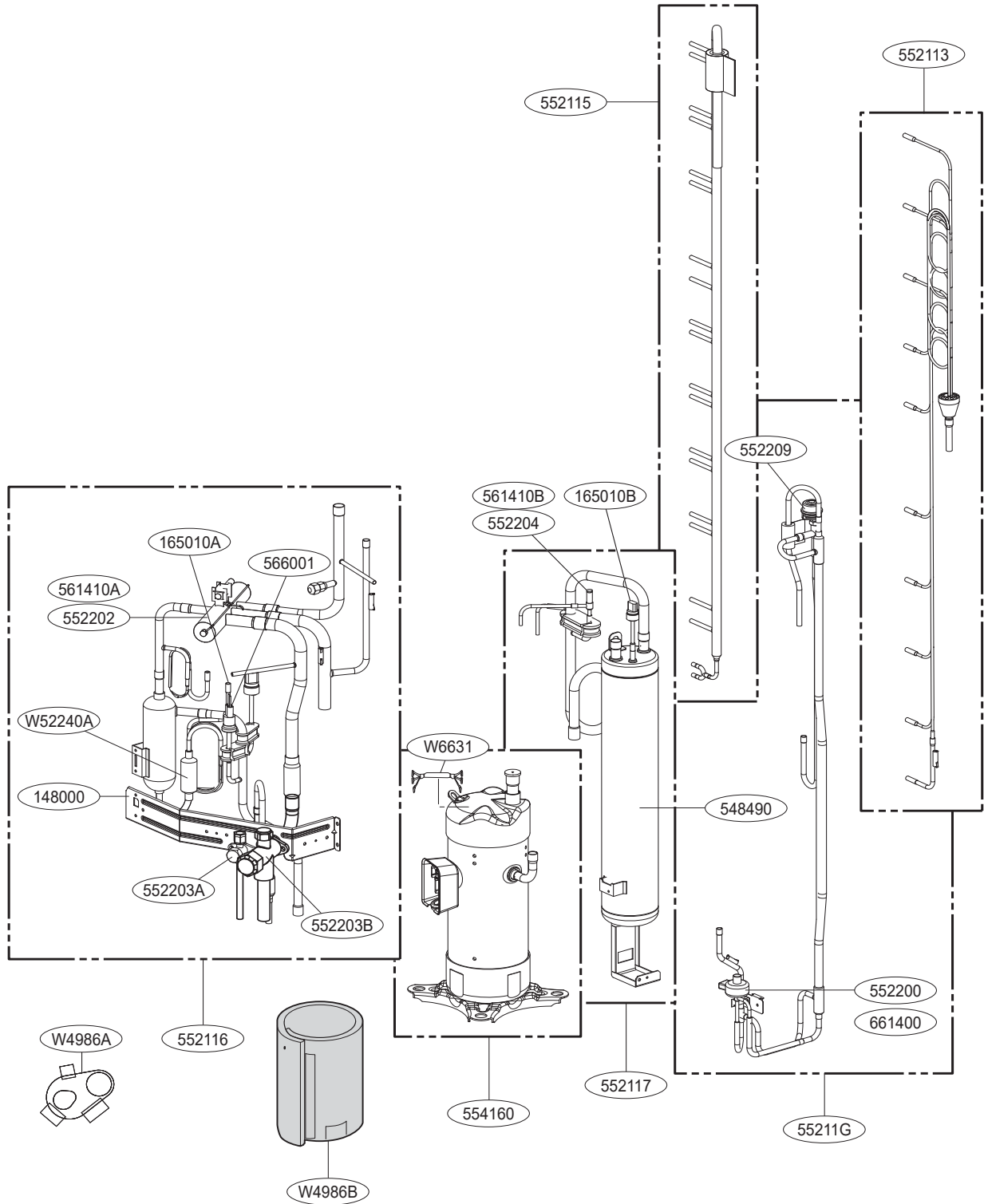

Parts

Note:

Actual component appearances will differ depending on manufacturing date, model, system type, etc.

OUTDOOR UNIT PARTS



Expanded Piping View

Expanded Piping View for ARUN060GSS4 Heat Pump Outdoor Units

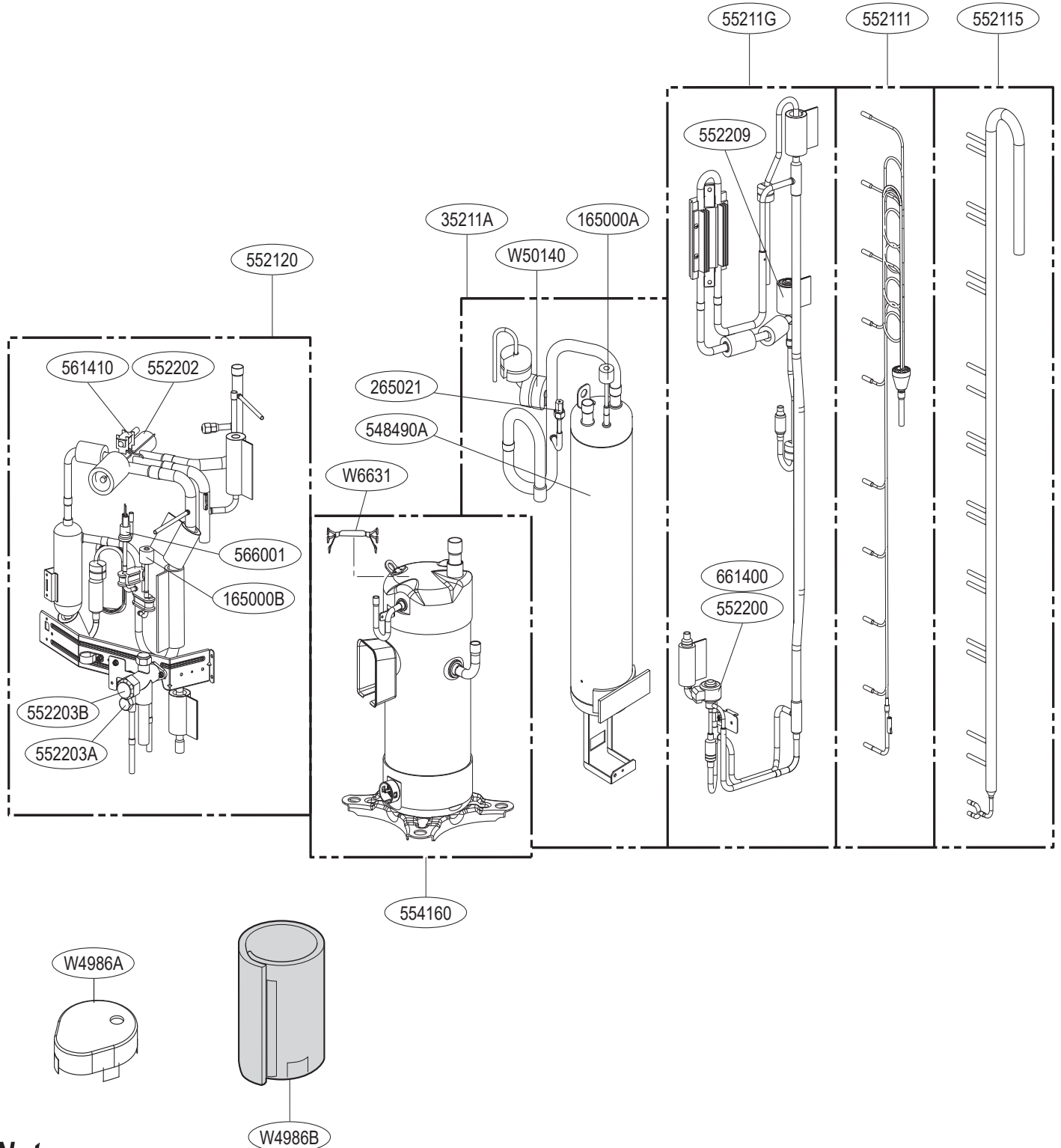

Note:

Actual component appearances will differ depending on manufacturing date, model, system type, etc.

Expanded Piping View for ARUB060GSS4 Heat Recovery Outdoor Units

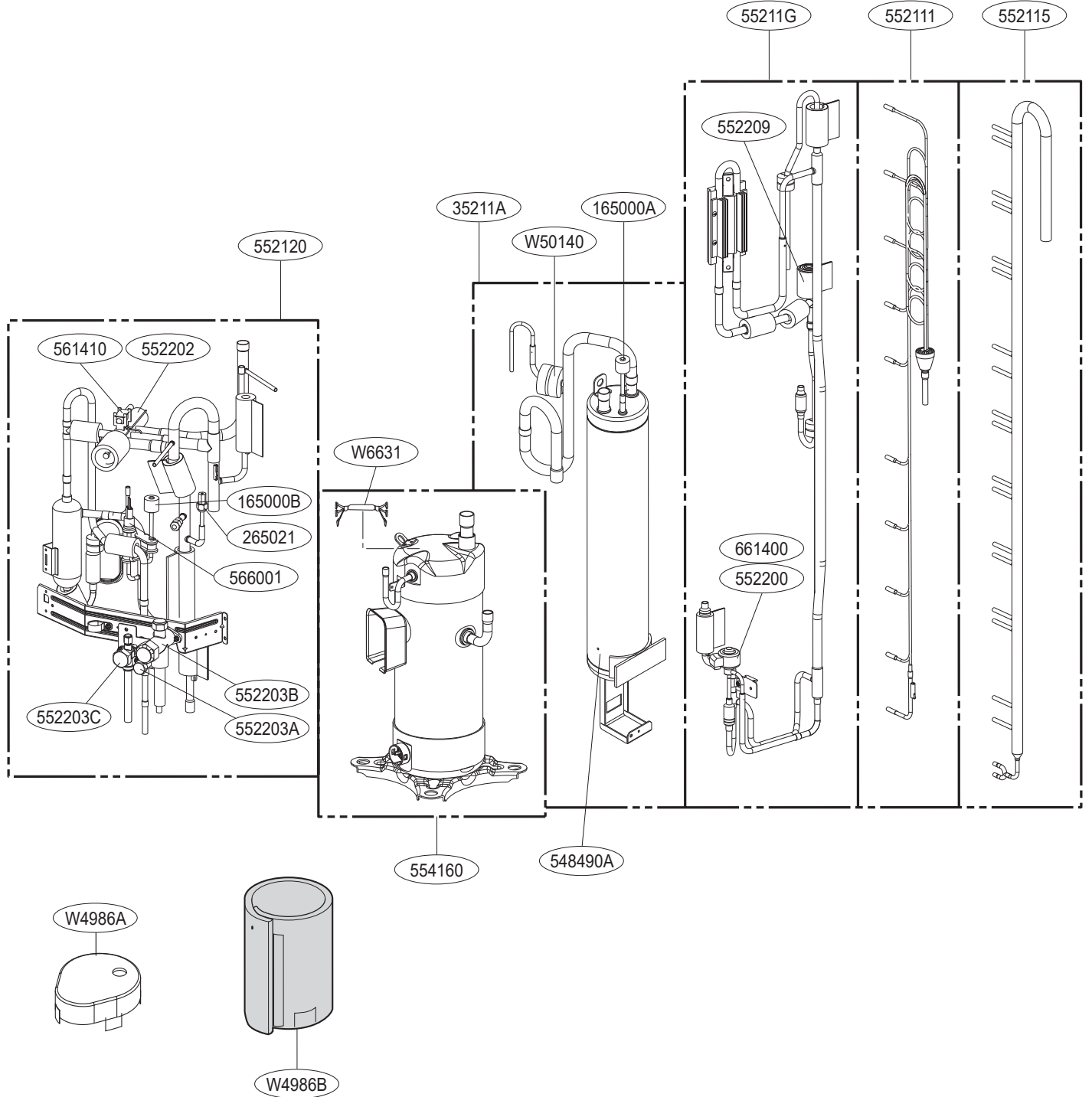

Parts

Note:

Actual component appearances will differ depending on manufacturing date, model, system type, etc.

Inverter



Refer to the Installation Manual posted on www.lghvac.com.



LG Electronics, U.S.A., Inc.
Air Conditioning Technologies
4300 North Point Parkway
Alpharetta, Georgia 30022
www.lghvac.com

SM_MultiV_S_OutdoorUnits_12_20
Supersedes: SM_MultiV_S_OutdoorUnits_10_18
SM_MultiV_S_OutdoorUnits_07_18