



Dishwashers
Lave-vaisselle

Ed.
02/2003

✓ 2004

Rev. C

050F

SPARE PARTS
PIECES DETACHEES



LISTED

COMMERCIAL DISHWASHERS ANS/NSF3

13CA



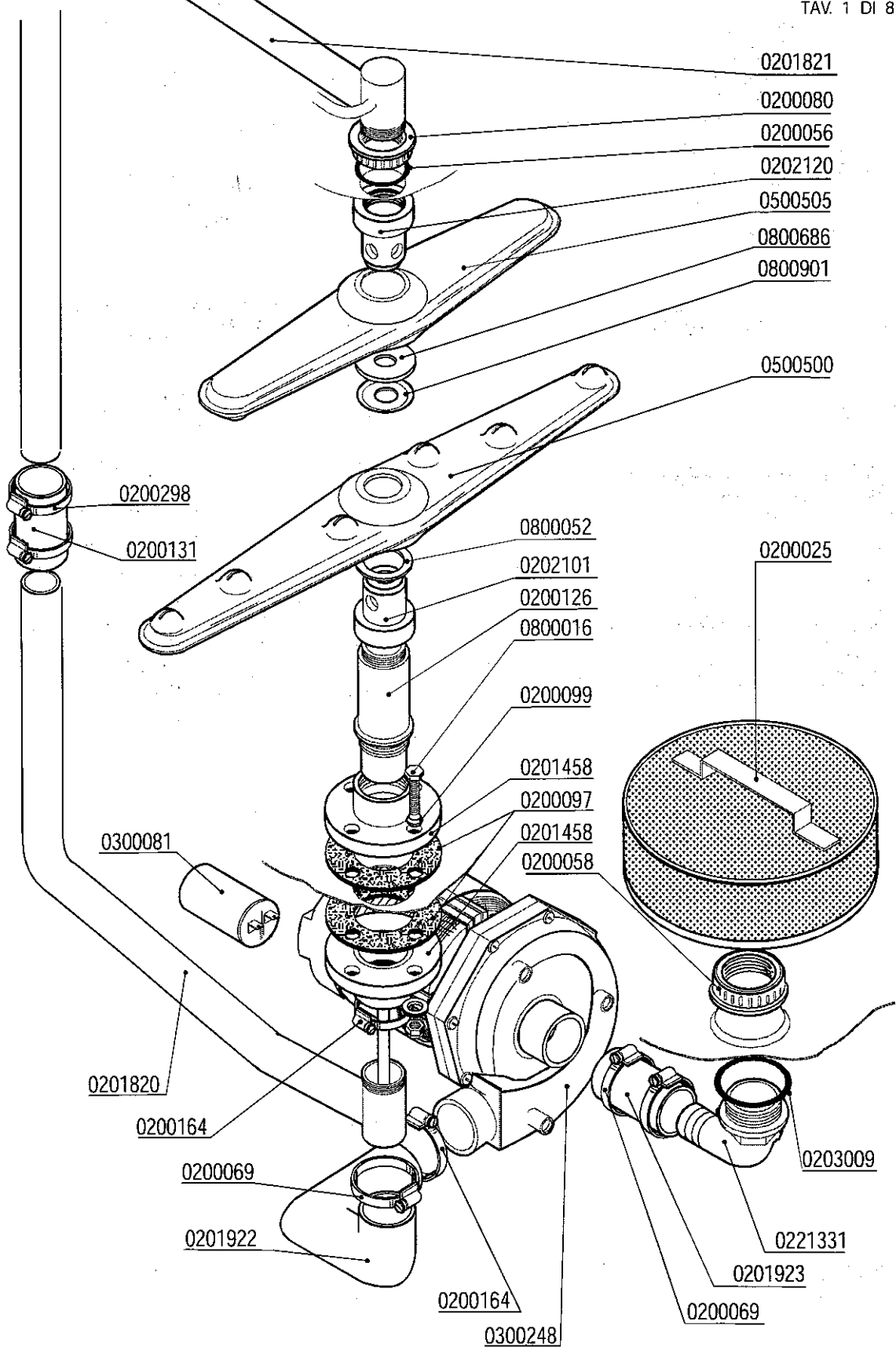

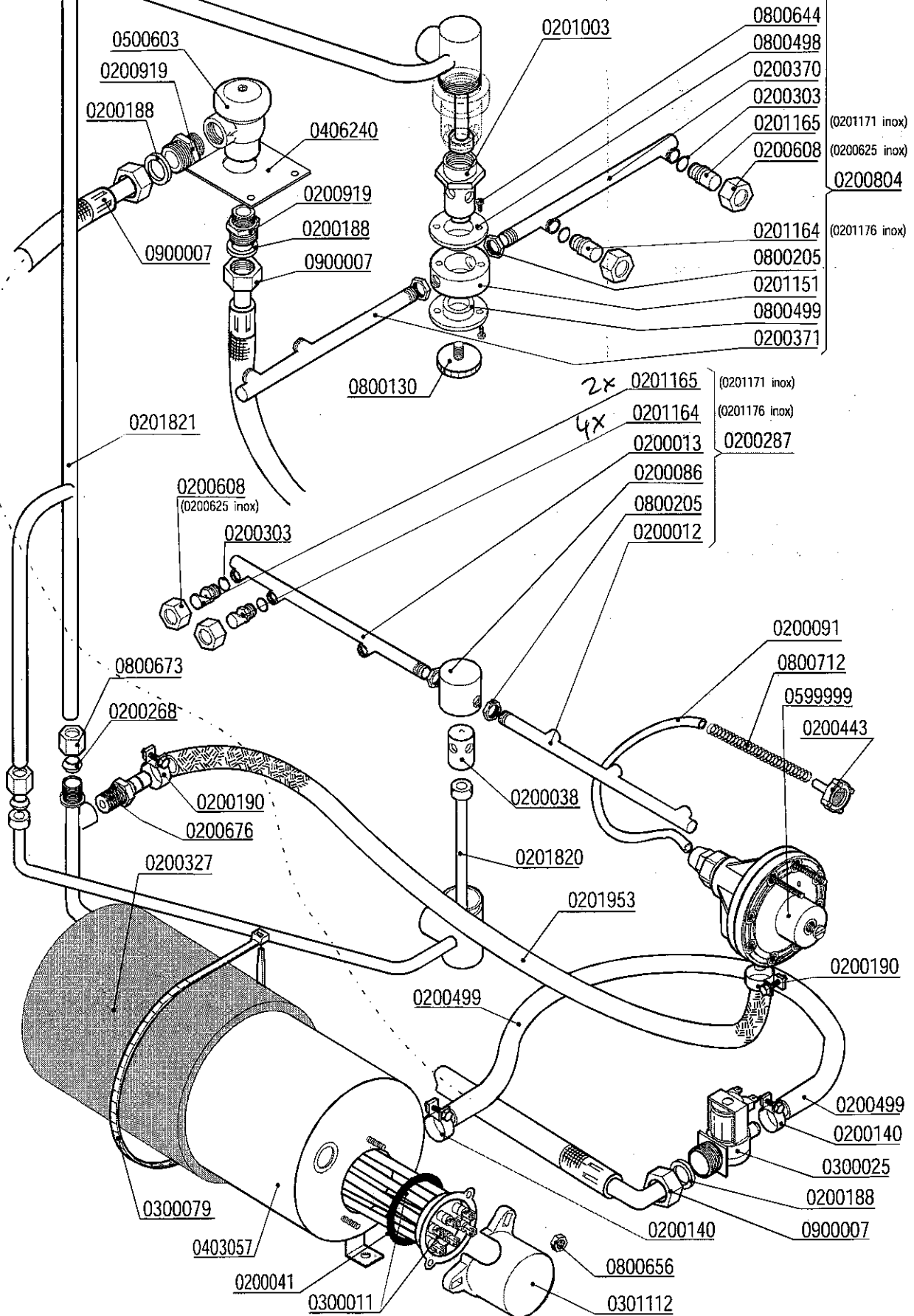

0500603

0200919

0200188

0900007

0201821

0200608
(0200625 inox)

0200303

0800673

0200268

0200190

0200676

0200327

0300079

0403057

0200041

0300011

0406240

0200919

0200188

0900007

0800130

0201003

2x 0201165

4x 0201164

0200013

0200086

0800205

0200012

0200038

0201820

0201953

0200499

0800656

0301112

0800644

0800498

0200370

0200303

0201165 (0201171 inox)

0200608 (0200625 inox)

0200804

0201164 (0201176 inox)

0800205

0201151

0800499

0200371

(0201171 inox)

(0201176 inox)

0200287

0200091

0800712

0599999

0200443

0200190

0200499

0200140

0300025

0200188

0900007

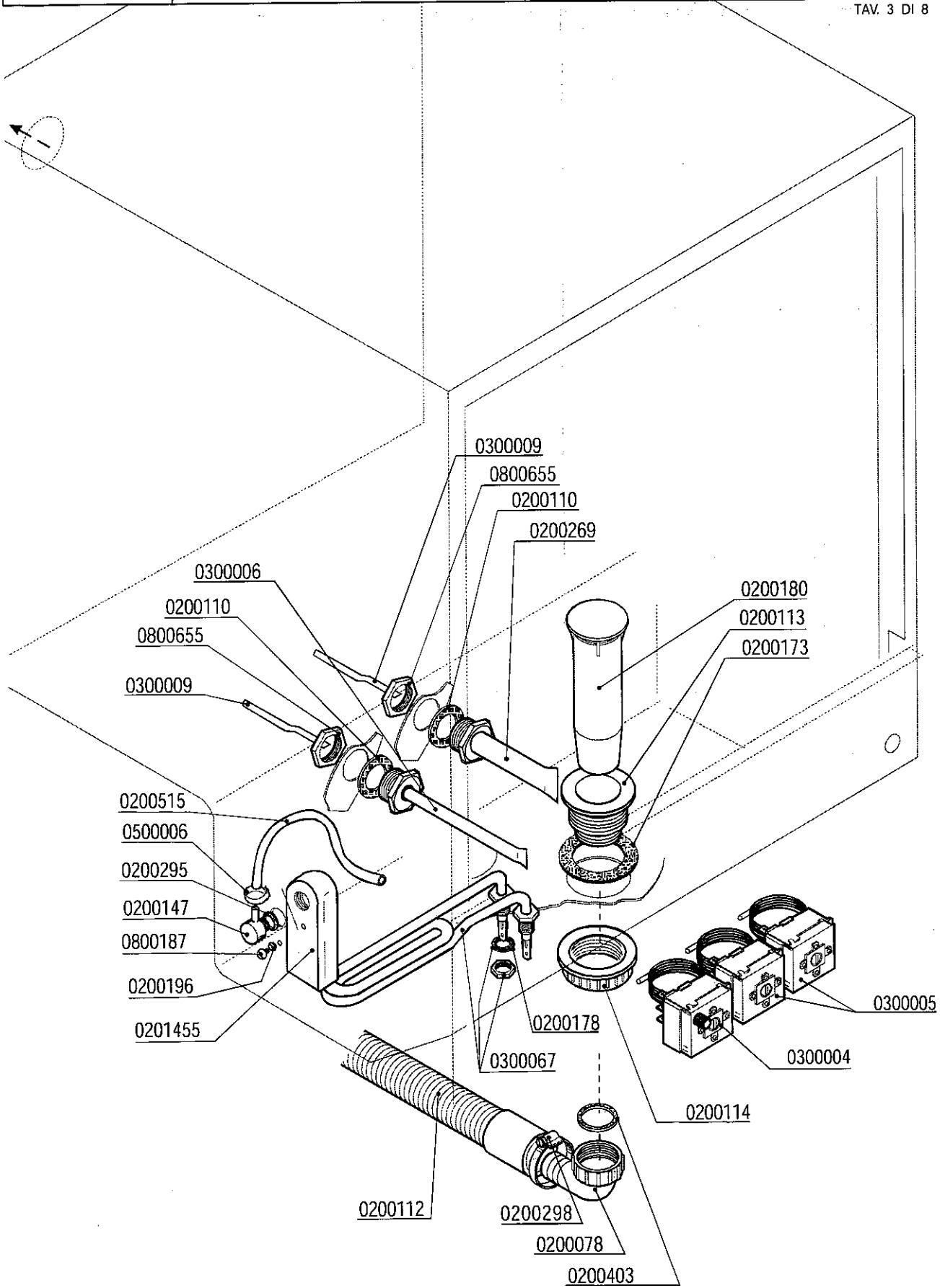

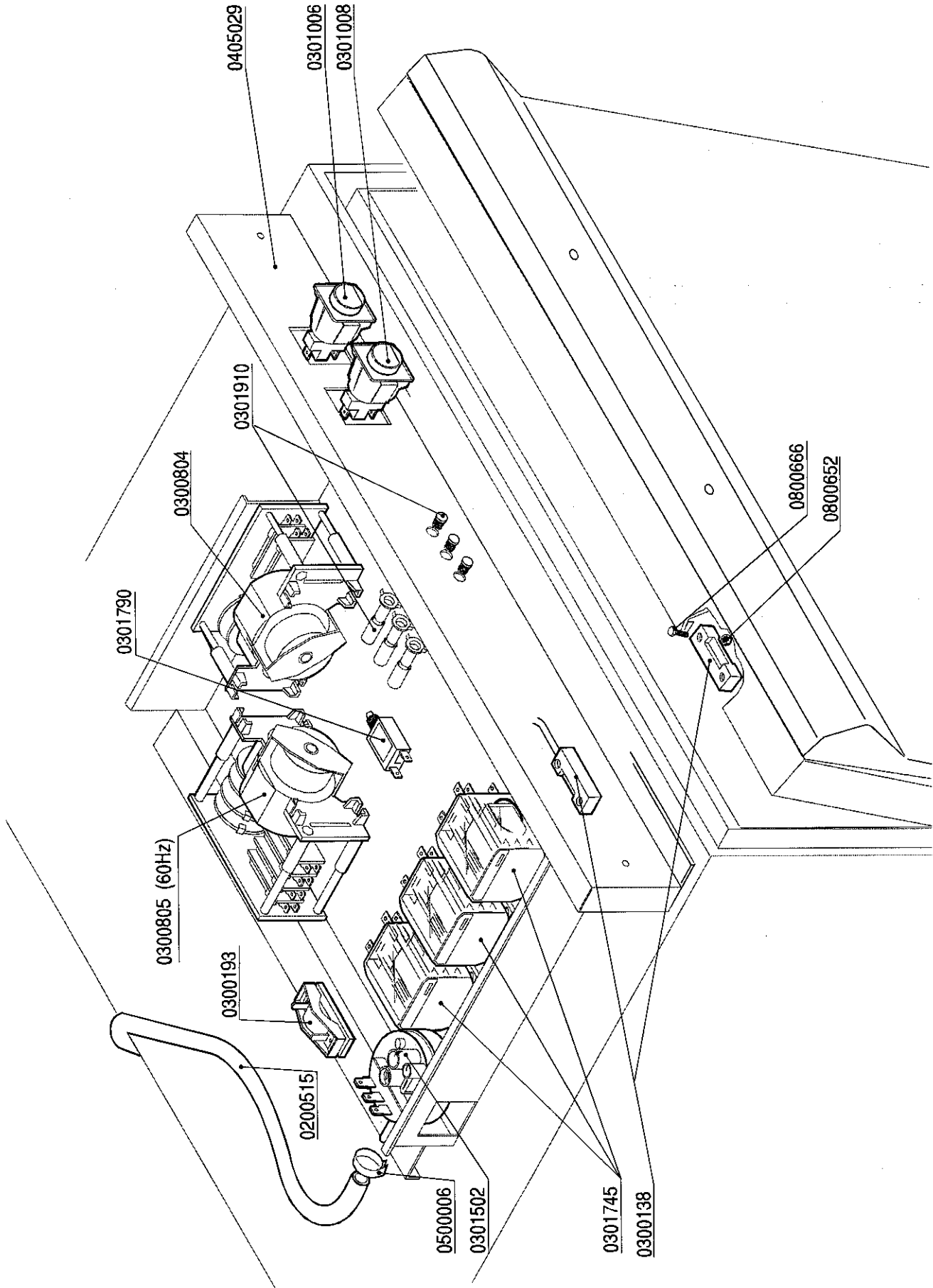



POMPE DE VIDANGE
DRAIN PUMP PARTS



MOD.

050F

TAV.

5 C

ED. 02/2003

TAV. 5 DI 8

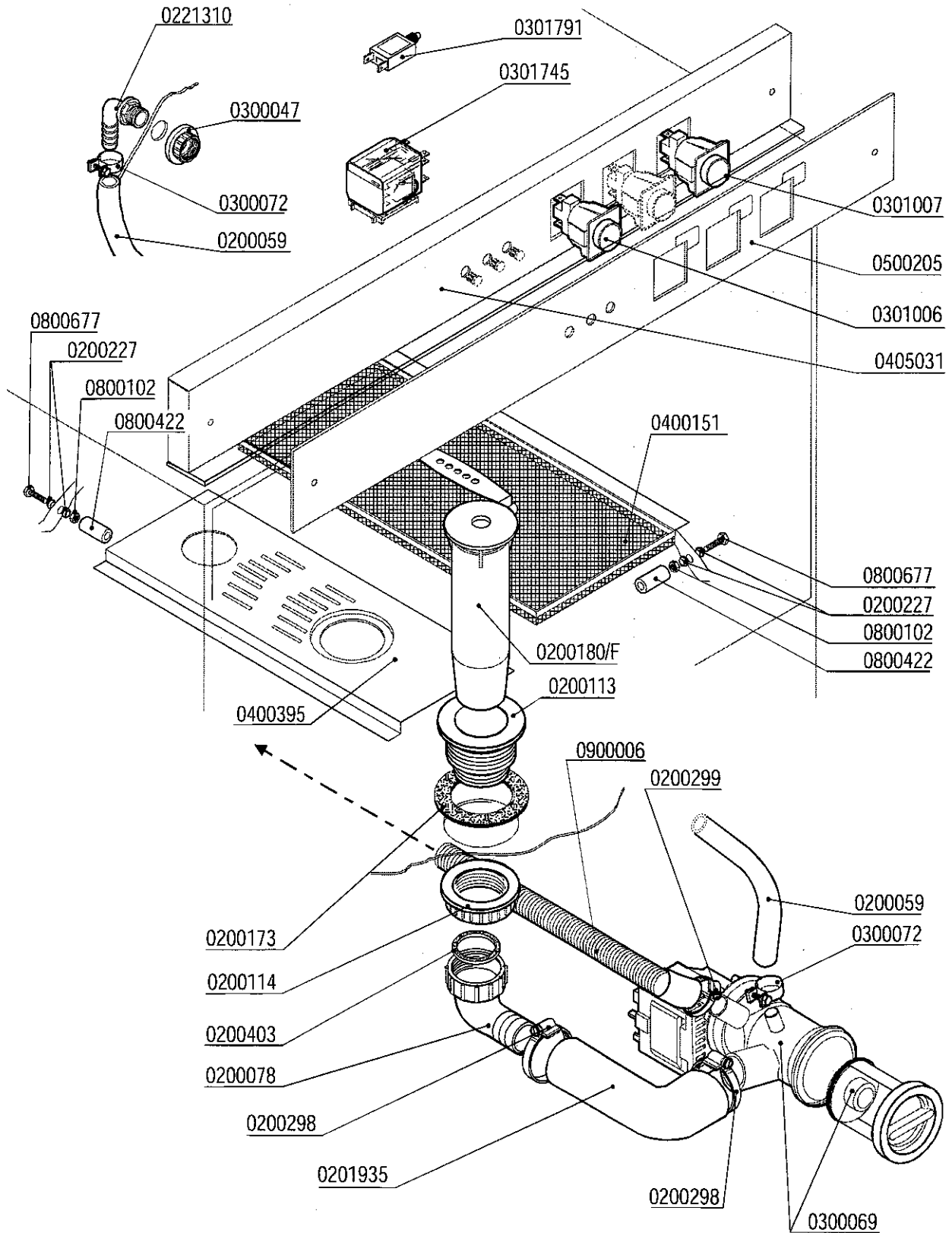

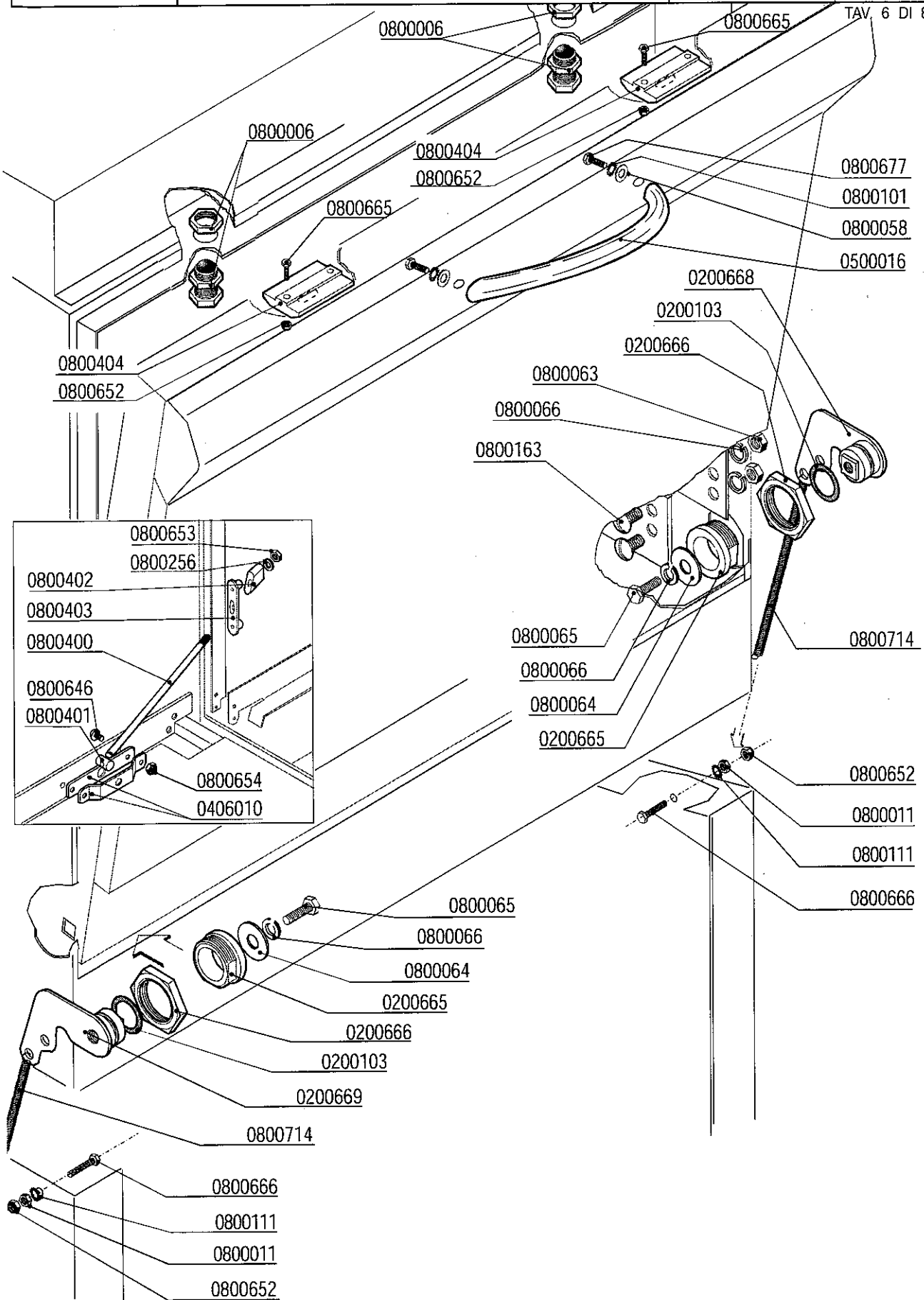

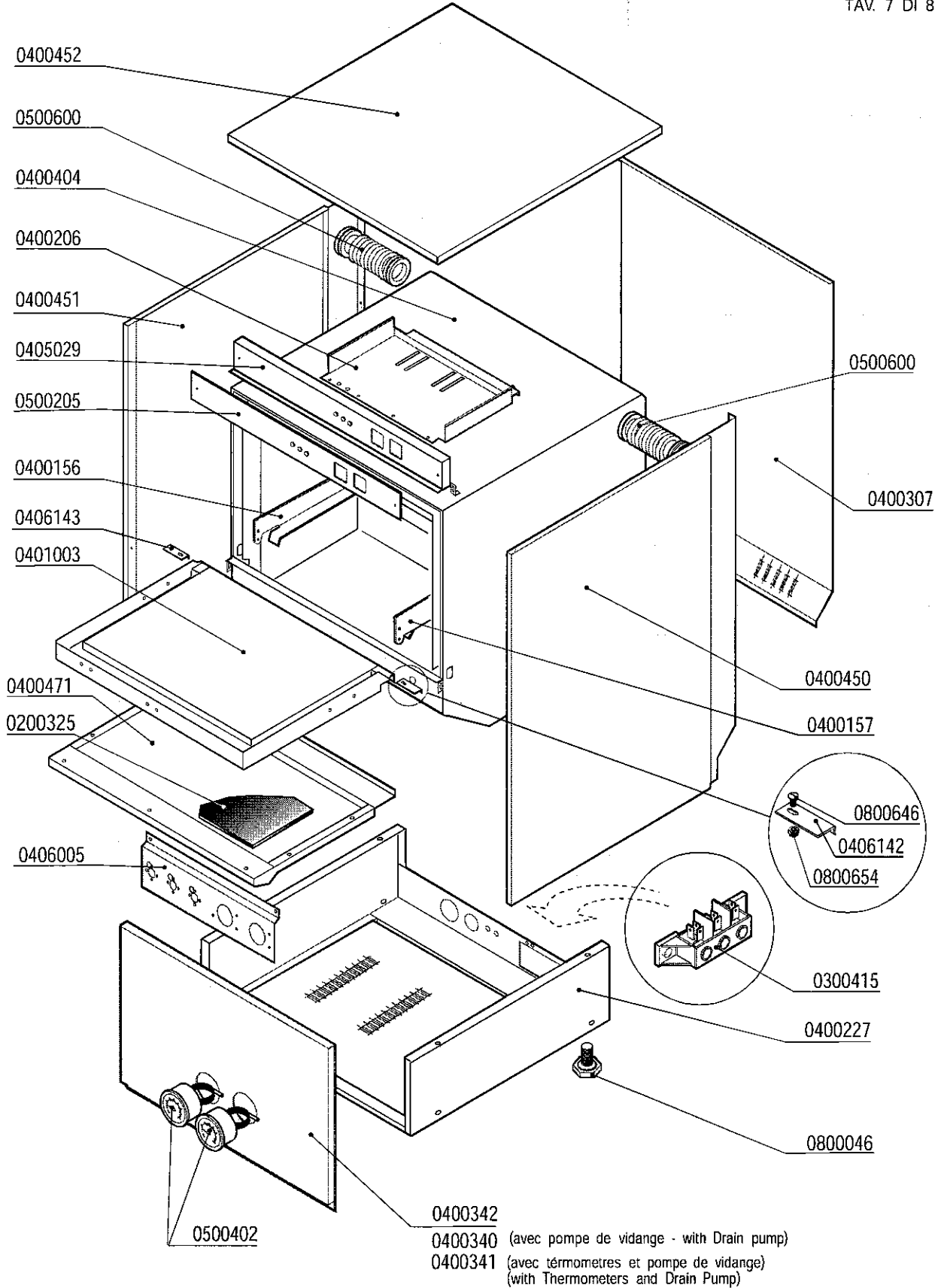

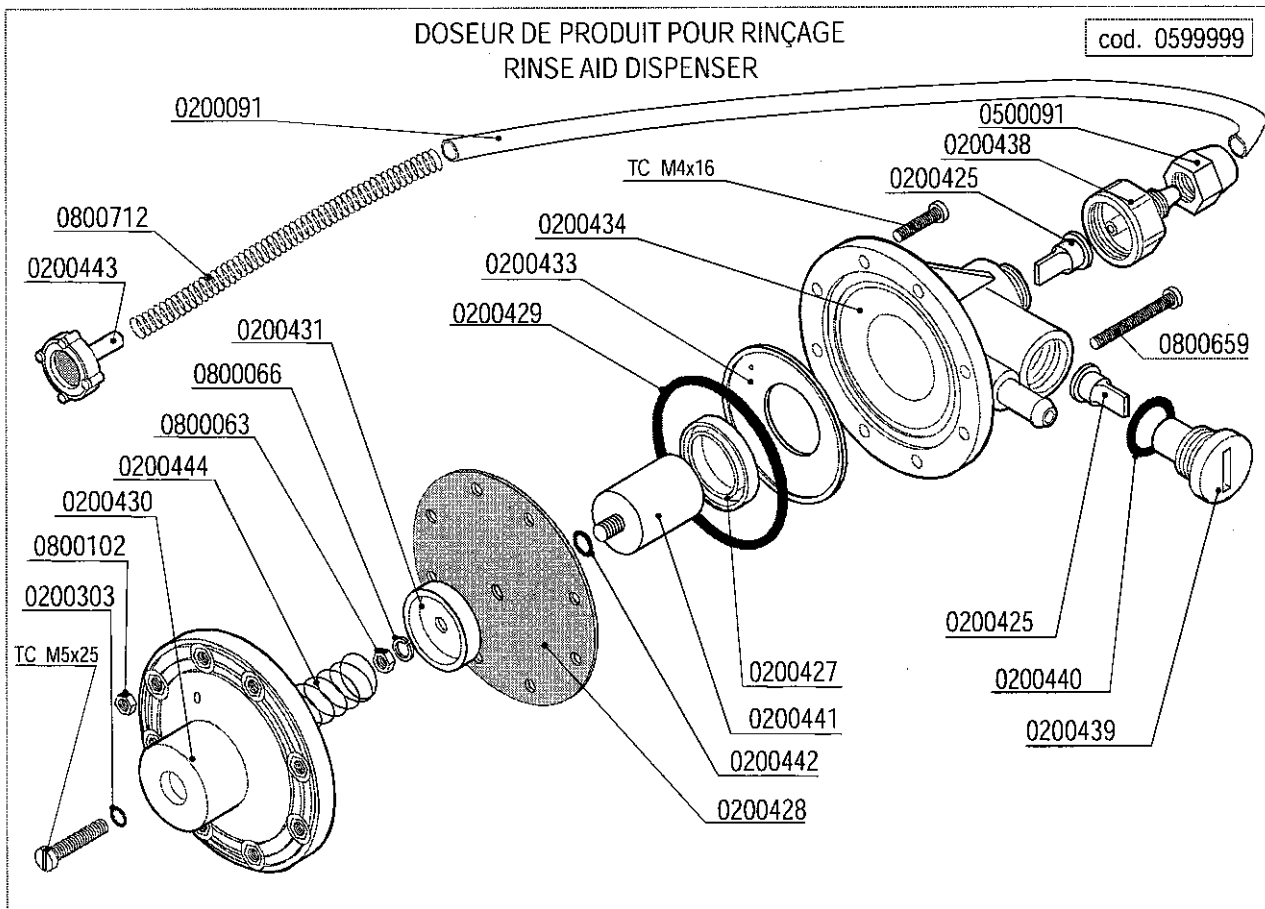
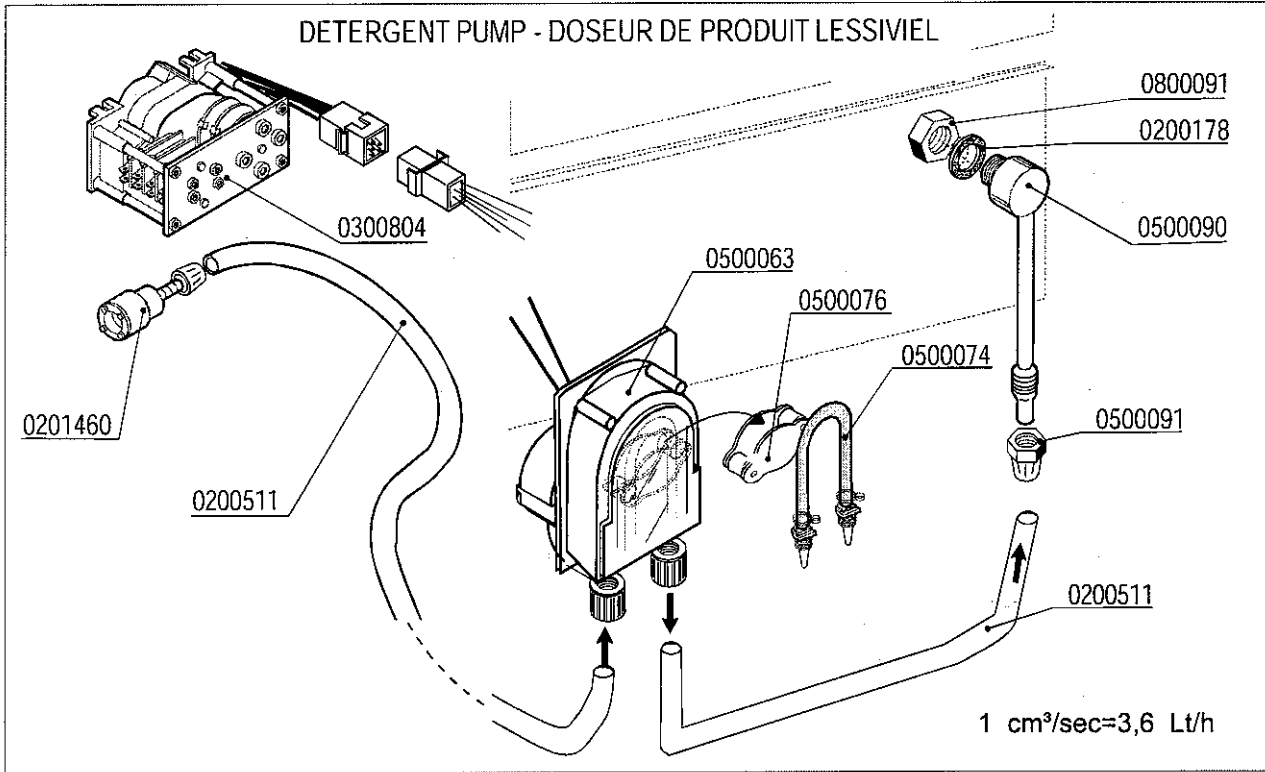

CONNECTIONS SCHEME SCHEMA BRANCHEMENTS

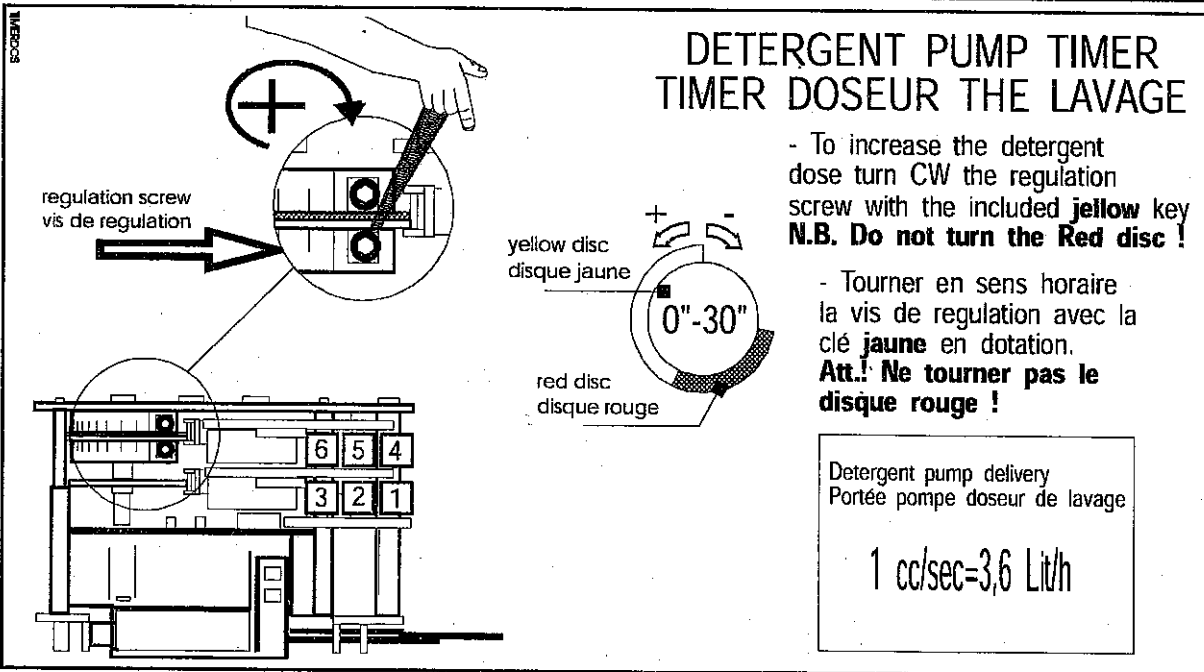
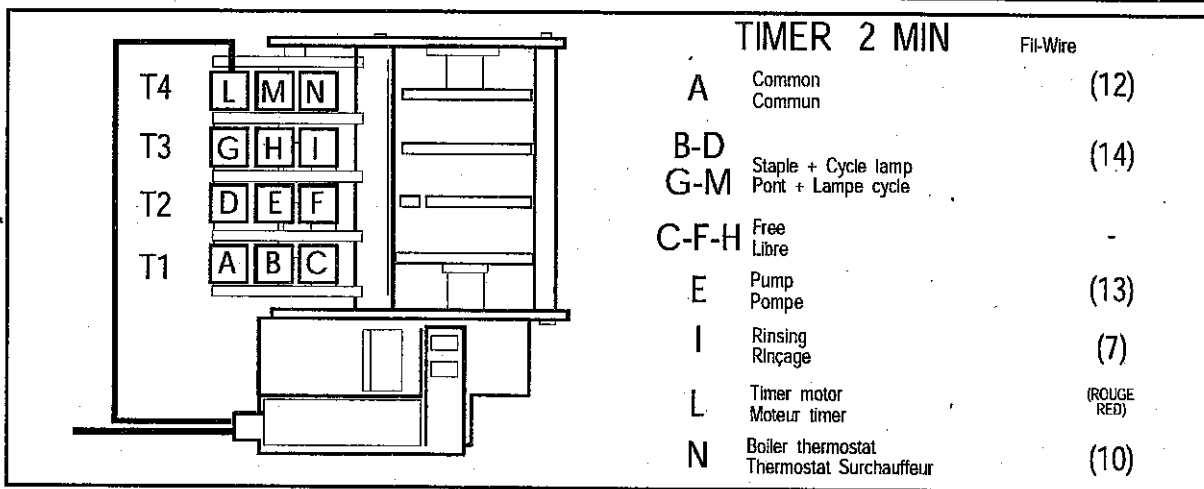
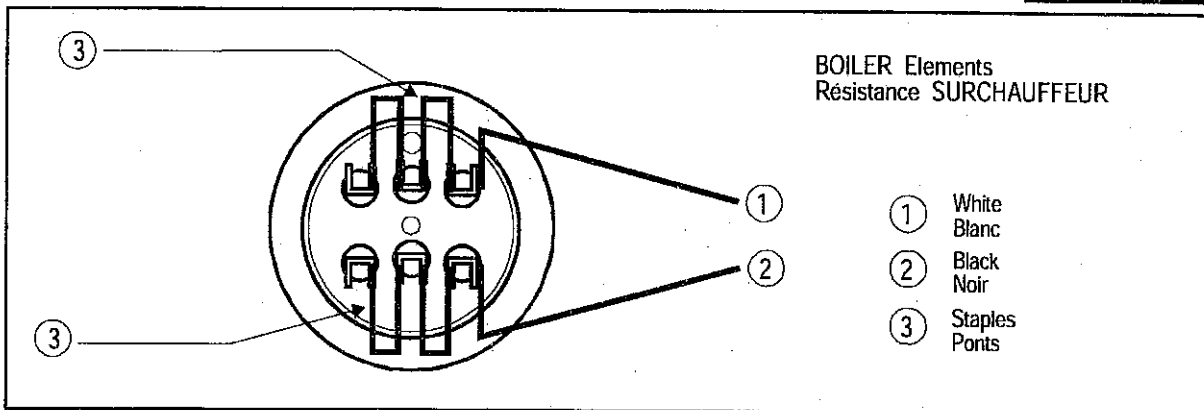



RINSE AID DISPENSER-DETERGENT PUMP
DOSEUR DE PRODUIT POUR RINÇAGE
ET POUR LAVAGE



MOD.

050F

TAV.

8 D

ED. 02/2005

TAV. 8 DI 8

DETERGENT PUMP - DOSEUR DE PRODUIT LESSIVIEL

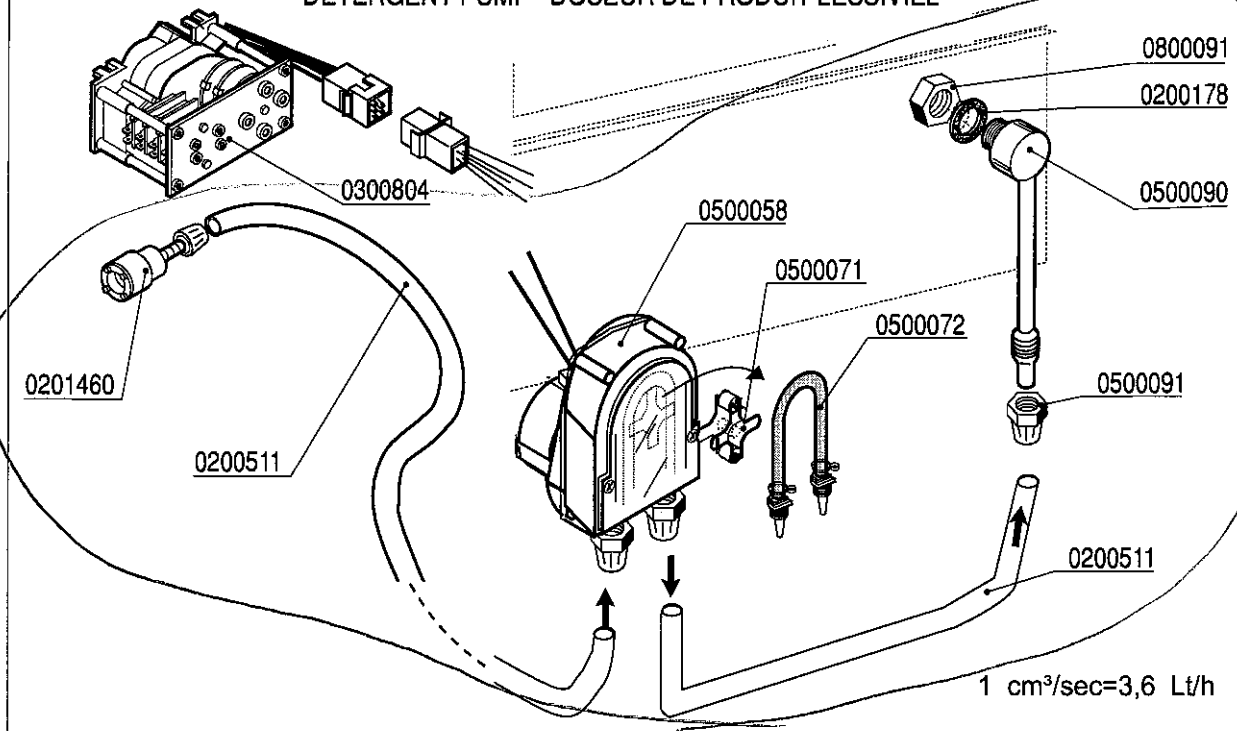

AC00221

DOSEUR DE PRODUIT POUR RINÇAGE
RINSE AID DISPENSER

cod. 0599999

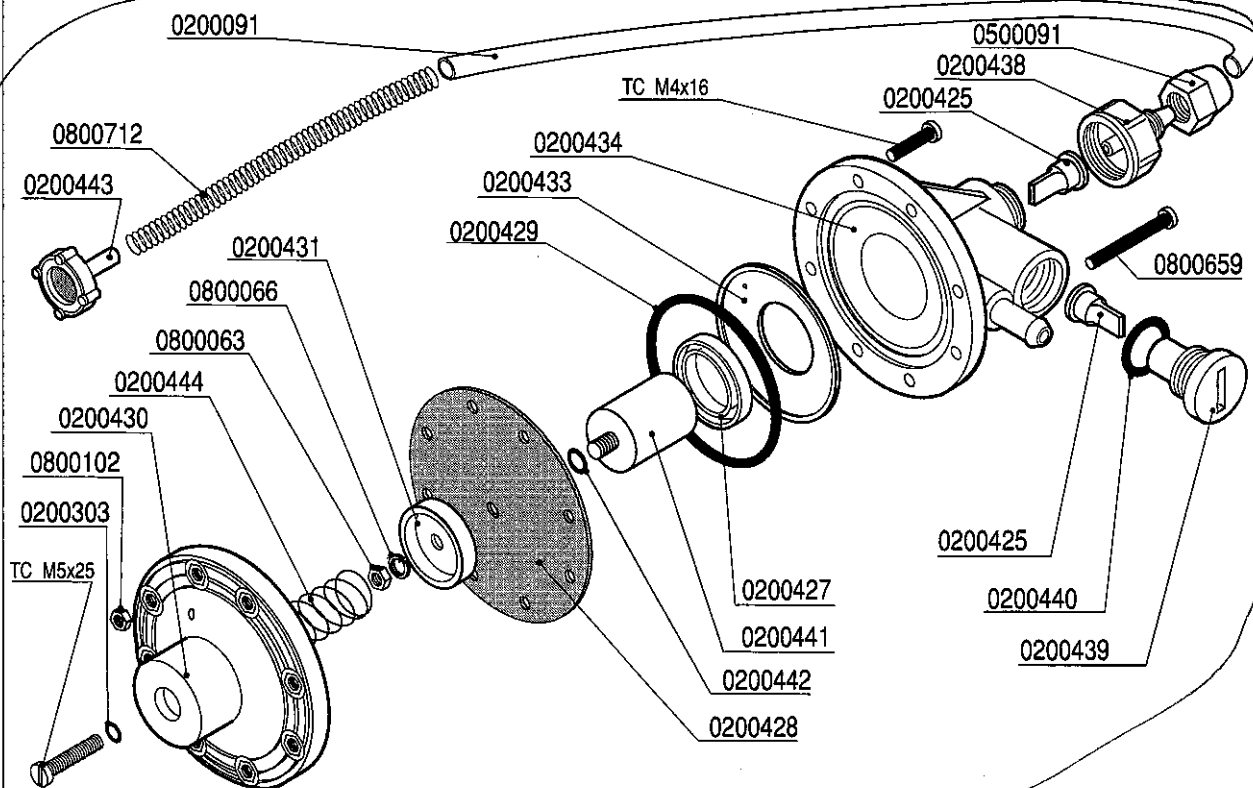

WIRING DIAGRAM

SCHEMA ELECTRIQUE

with detergent pump
avec doseur de produit lessiviel

050F
208/1 ~60Hz

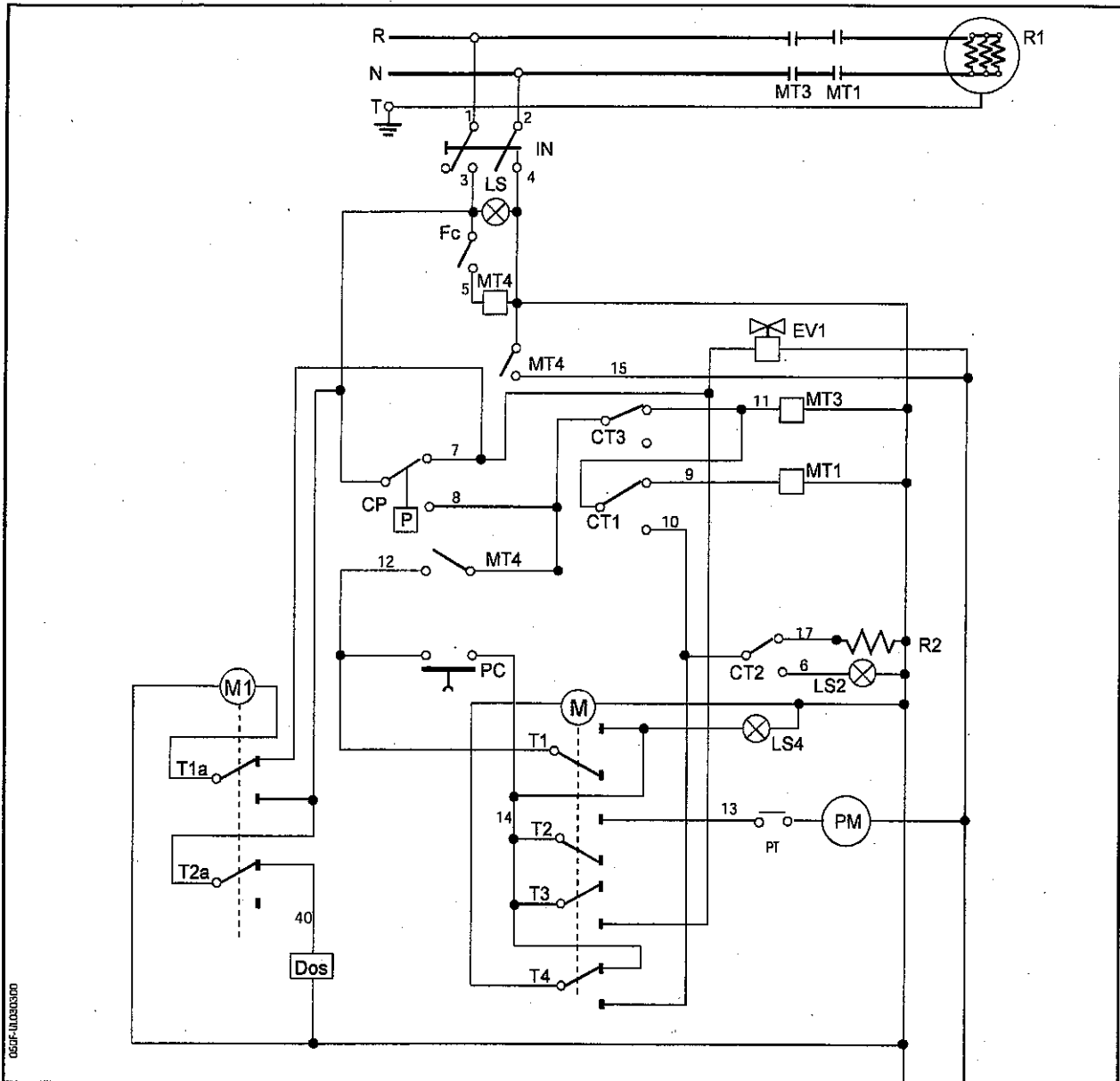

IN	Main switch	Interrupteur général	IN
Fc	Limit switch	Microinterrupteur	Fc
R1	Boiler elements	Résistance Surchauffeur	R1
R2	Tank elements	Résistance Cuve	R2
LS	Main switch lamp	Lampe de ligne	LS
LS2	temperature elements lamp	Lampe température	LS2
LS4	Cycle lamp	Lampe de cycle	LS4
MT1	Boiler elements contactor	Contacteur rés. surchauffeur	MT1
MT3	Security contactor	Contacteur de sureté	MT3
MT4	Limit switch contactor	Contacteur Microinterrupteur	MT4
CP	Pressure switch	Pressostat	CP
CT1	Boiler thermostat	Thermostat Surchauffeur	CT1
CT2	Tank thermostat	Thermostat Cuve	CT2
CT3	Security thermostat	Thermostat de sureté	CT3
M	Timer motor	Moteur Timer	M
T1-T4	Timer	Timer	T1-T4
PM	Electric pump	Pompe de lavage	PM
EV1	Loading and rinsing solenoid valve	Electrovanne chargement et rinçage	EV1
PC	Cycle pushbutton	Bouton cycle	PC
PR	Cold rinsing pushbutton	Bouton rinçage froid	PRF
Dos	Detergent pump	oseur de produit lessiviel	Dos
PT	Electric pump thermal	Protection thermique	PT
M1	Deterg. pump timer motor	Moteur doseur produit lessiviel	M1
T1a-T2a	Detergent pump timer	Timer doseur produit lessiviel	T1a-T2a