

PS536 Parts
Gas & Electric
Domestic & Std. Export

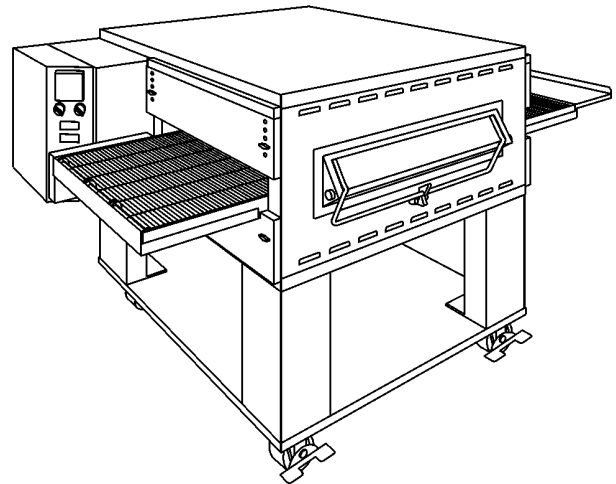

PMD-15-004
Rev. E • V2 • 7/02

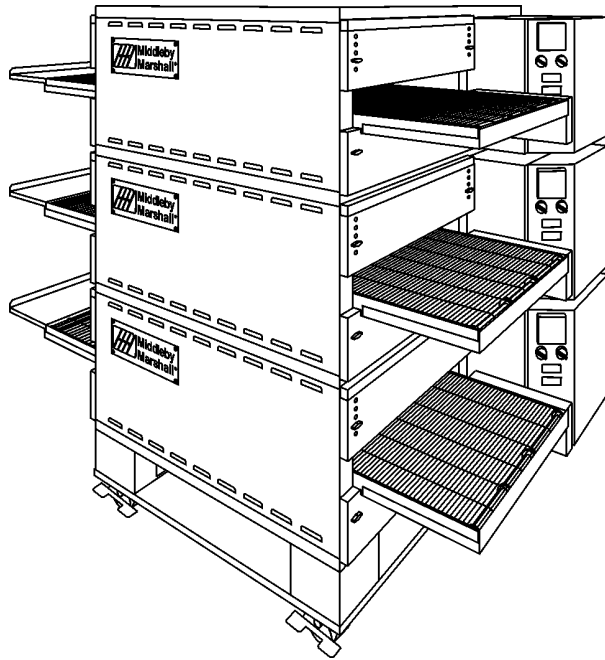

PS536
USA & Std. Export

PS536 Gas and Electric Ovens

PARTS MANUAL

for domestic and standard export ovens

© 2002 Middleby Marshall, Inc.

 Middleby Marshall® is a registered trademark of Middleby Marshall, Inc. All rights reserved.

Middleby Cooking Systems Group • 1400 Toastmaster Drive • Elgin, IL 60120 • (847)741-3300 • FAX (847)741-4406

TABLE OF CONTENTS

Section	Page
I. KEY SPARE PARTS KIT	3
II. INSTALLATIONKIT	4
III. TOP PANEL, BASE PAD, LEGS AND STACKING COMPONENTS	6
IV. PANELS, END PLUGS, WINDOW AND COOL FRONT	8
V. CONTROL COMPARTMENT FOR ELECTRIC OVENS	10
VI. CONTROL COMPARTMENT FOR GAS OVENS	12
VII. BLOWER ASSEMBLY	14
VIII. HEATING ELEMENTS	16
IX. GAS TRAIN ASSEMBLY	18
X. BAR-FRAME SINGLE-BELT CONVEYORS, 60"/1.52m (ORIGINAL STANDARD)	20
<i>Type 1: Produced through 3/01. 1.52m long, non-folding after assembly, center tension adjustment</i>	
<i>Type 2: Produced 4/01-current. 1.52m long, folding, center tension adjustment</i>	
XI. BAR-FRAME SPLIT-BELT CONVEYORS, 60"/1.52m (ORIGINAL STANDARD)	22
<i>Type 1: Produced through 3/01. 1.52m long, non-folding after assembly, center tension adjustment</i>	
<i>Type 2: Produced 4/01-current. 1.52m long, folding, center tension adjustment</i>	
XII. BAR-FRAME SINGLE-BELT CONVEYOR, 56"/1.42m (PIZZA HUT)	24
<i>Produced 10/01-current. 1.42m long, folding, center tension adjustment</i>	
XIII. BAR-FRAME SINGLE-BELT CONVEYOR, 60"/1.52m, WITH EXTERNAL BEARINGS (SCHLOTZSKY'S) ...	26
<i>Produced 3/01-current. 1.52m long, folding, center tension adjustment, external bearings</i>	
XIV. "C" CHANNEL-FRAME SINGLE BELT CONVEYOR, 60"/1.52m (OLIVE GARDEN OR CURRENT STANDARD)	28
<i>Produced 4/01-current. 1.52m long, folding, endplate thumbscrew tension adjustment</i>	
XV. "C" CHANNEL-FRAME SPLIT-BELT CONVEYOR, 60"/1.52m (CURRENT STANDARD)	30
<i>Produced 1/02-current. 1.52m long, folding, endplate thumbscrew tension adjustment</i>	
XVI. "C" CHANNEL-FRAME SINGLE BELT CONVEYOR, 76"/1.93m (McDONALD'S OR 76" STANDARD)	32
<i>Produced 4/01-current. 1.93m long, non-folding after assembly, endplate thumbscrew tension adjustment</i>	

NOTE: Throughout this Parts Manual, the following abbreviations are used:

A/R = Quantity As Required

N/A = Does Not Apply

WARNING

FOR YOUR SAFETY DO NOT STORE OR USE GASOLINE OR OTHER FLAMMABLE VAPORS AND LIQUIDS IN THE VICINITY OF THIS OR ANY OTHER APPLIANCE

WARNING

Improper installation, adjustment, alteration, service or maintenance can cause property damage, injury or death. Read the installation, operating and maintenance instructions thoroughly before installing or servicing this equipment.

WARNING

DISCONNECT THE OVEN FROM ITS ELECTRICAL POWER SUPPLY BEFORE SERVICING.

NOTICE

Using any parts other than genuine Middleby Marshall factory manufactured parts relieves the manufacturer of all warranty and liability.

NOTICE

Middleby Marshall (Manufacturer) reserves the right to change specifications at any time.

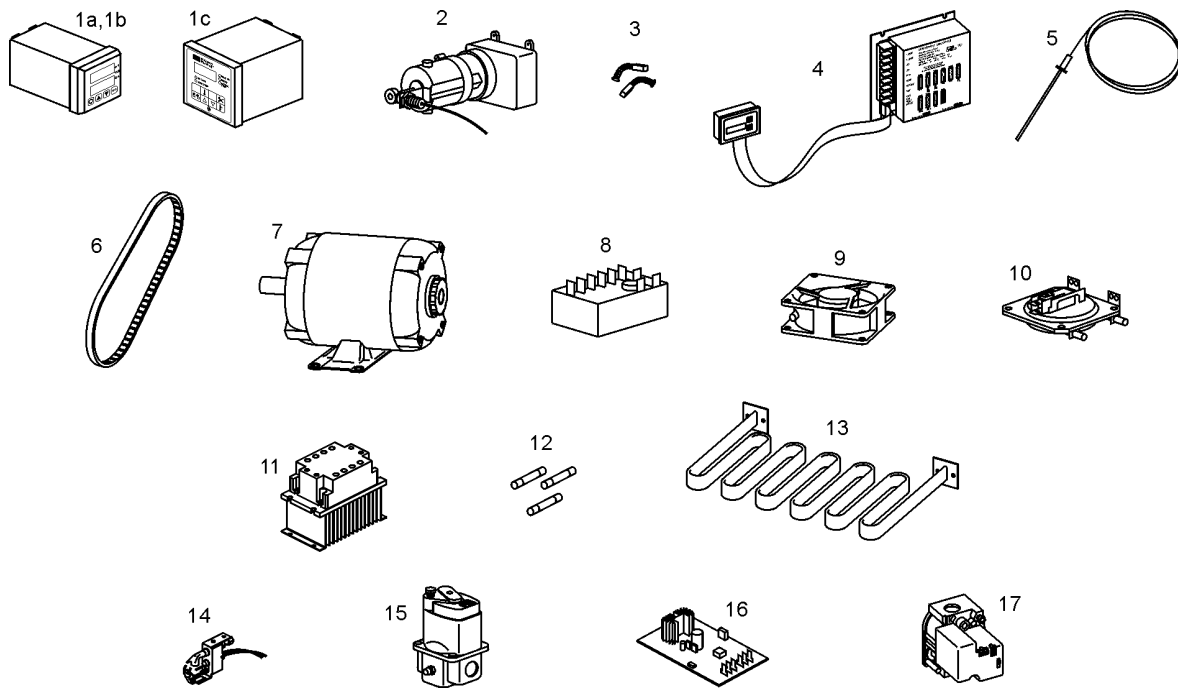

I. KEY SPARE PARTS KIT

ITEM	QTY.	P/N	DESCRIPTION
1	1	44783	DIGITAL TEMPERATURE CONTROLLER, ELECTRIC OVENS
1b	1	44823	DIGITAL TEMPERATURE CONTROLLER, GAS OVENS THROUGH 2/01
1c	1	36939	DIGITAL TEMPERATURE CONTROLLER, GAS OVENS 3/01-CURRENT
2	1	44695	CONVEYOR DRIVE MOTOR W/PICKUP ASSY.
3	2	30153	DRIVE MOTOR BRUSHES
4	1	37337	KIT, CONVEYOR SPEED CONTROLLER
5	1	33985	KIT, THERMOCOUPLE
6	1	44685	BELT, BLOWER
7a	1	44687	MOTOR, BLOWER, 208/230V, 1/2 HP
7b	1	46907	MOTOR, BLOWER, 430V, 1/3 HP (430V ELECTRIC OVENS ONLY)
8a	1	33983	HIGH LIMIT CONTROL MODULE, 230V
8b	1	34982	HIGH LIMIT CONTROL MODULE, 115V (430V ELECTRIC OVENS ONLY)
9a	1	97525	AXIAL COOLING FAN, 230V
9b	1	27381-0001	AXIAL COOLING FAN, 115V (430V ELECTRIC OVENS ONLY)
10	1	39530	AIR SWITCH, 230V
ELECTRIC OVENS ONLY:			
11	1	44585	RELAY AND HEAT SINK ASSEMBLY
12	3	44701	FUSE, 60A
13a	1	43094	HEATING ELEMENT, 208V 8 kW
13b	1	44800	HEATING ELEMENT, 230V 8 kW
13c	1	45281	HEATING ELEMENT, 380V 8 kW
GAS OVENS ONLY:			
14	1	44982	PILOT ASSEMBLY
15	1	41647	MODULATING GAS VALVE, 1/2"
16	1	31651	AMPLIFIER BOARD
17	1	45003	COMBINATION GAS CONTROL VALVE

PS536
USA & Std. Export

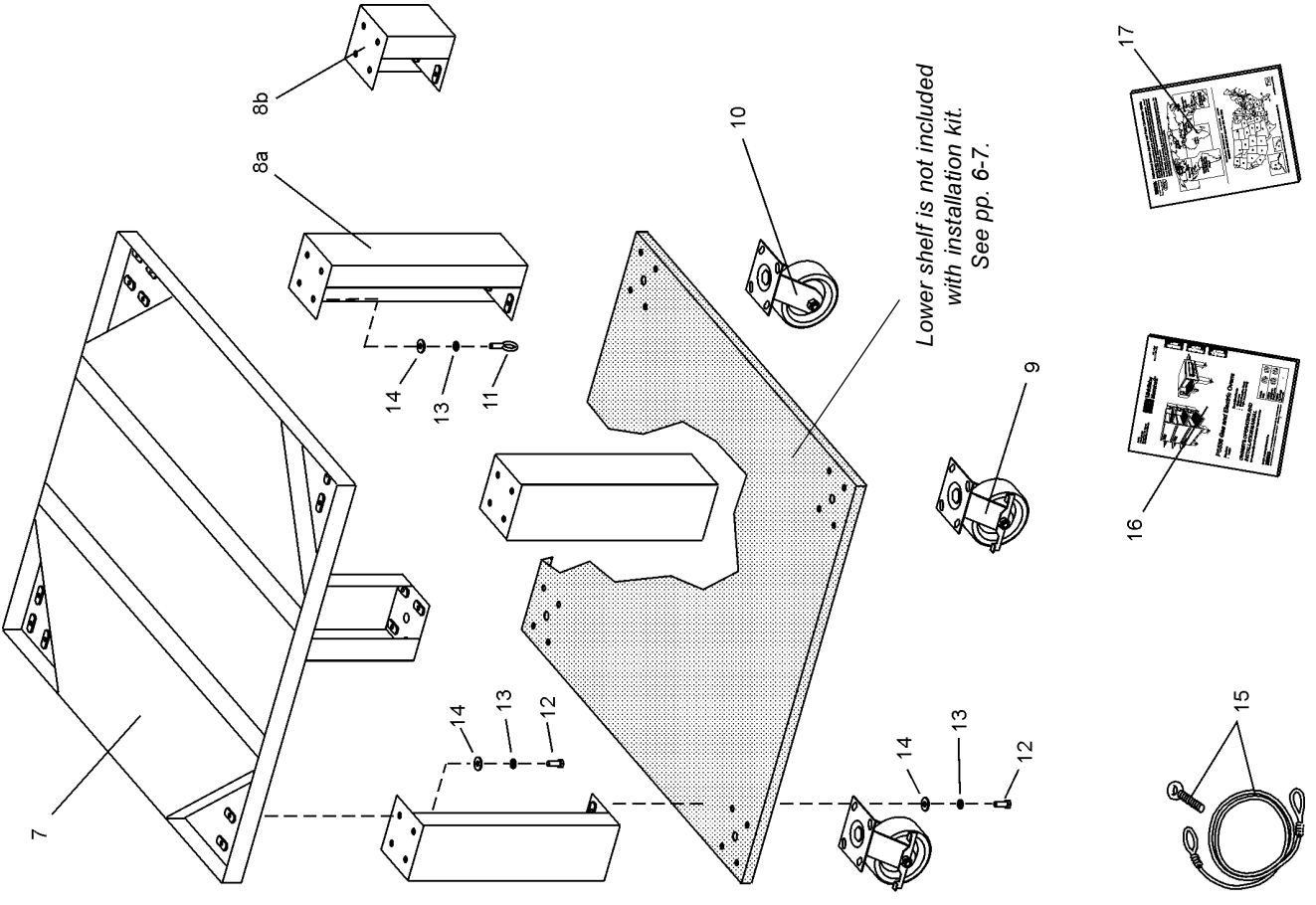
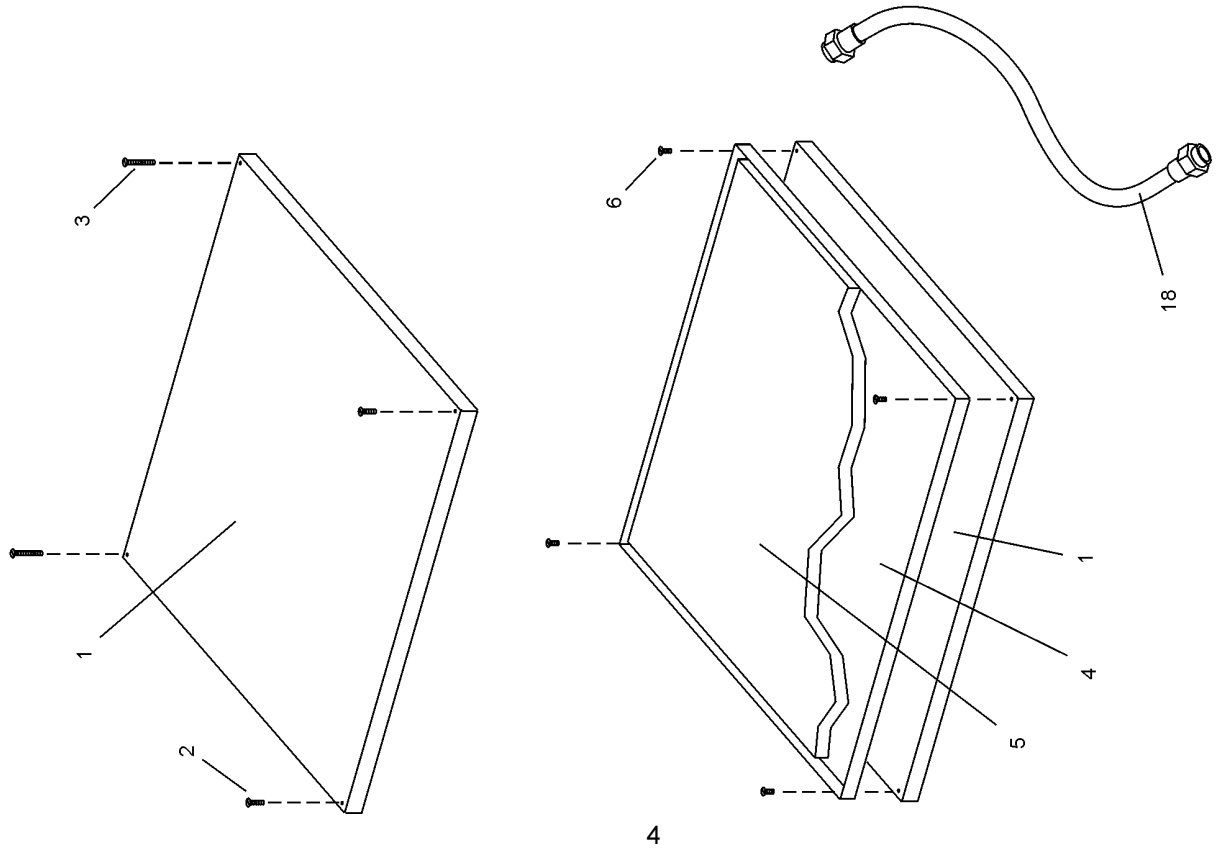

II. INSTALLATION KIT

ITEM	QTY.		PART NO.	DESCRIPTION
	SINGLE OVEN	DOUBLE OVEN		
1	1	2	42882	TOP PANEL
2	2	2	220352	SCREW, PAN HEAD #10 X 1" (TOP PANEL - FRONT)
3	2	2	3A80A8801	SCREW, PAN HEAD #10 X 2" (TOP PANEL - REAR)
4	--	1	44837	STACKING PANEL
5	--	1	44918	INSULATION, STACKING PANEL, PRE-CUT
6	--	4	4111A8815	SCREW, HEX HEAD #10-32 X 1/2" (STACKING PANELS)
7	1	1	42893	BASEPAD
8a	4	4	42890	17-1/2" (445mm) LEG EXTENSION (STANDARD), SINGLE & DOUBLE OVENS
8b	--	--	44799	6" (152mm) LEG EXTENSION (STANDARD), TRIPLE OVENS
8c	4	4	45329	23-1/2" (597mm) LEG EXTENSION (CUSTOM), SINGLE OVENS
8d	4	4	45360	20-1/2" (521mm) LEG EXTENSION (CUSTOM), SINGLE & DOUBLE OVENS
9	2	2	22290-0009	CASTER, WITH FLAT PLATE AND BRAKE
10	2	2	22290-0010	CASTER, WITH FLAT PLATE (NO BRAKE)
11	1	1	21392-0004	EYEBOLT, 3/4"
12	31	31	220373	HEX BOLT, 3/8"-16 X 1"
13	32	32	21416-0001	FLAT WASHER, 3/8"
14	32	32	21422-0001	LOCKWASHER, 3/8"
15	1	1	22450-0228	RESTRAINT CABLE ASSEMBLY
16	1	1	44727	OWNER'S OPERATING AND INSTALLATION MANUAL, PS536 GAS AND ELECTRIC OVENS
17	1	1	1002040	MIDDLEBY MARSHALL AUTHORIZED SERVICE AGENCY LISTING
GASOVENS ONLY:				
18	1	2	22361-0001	GAS HOSE

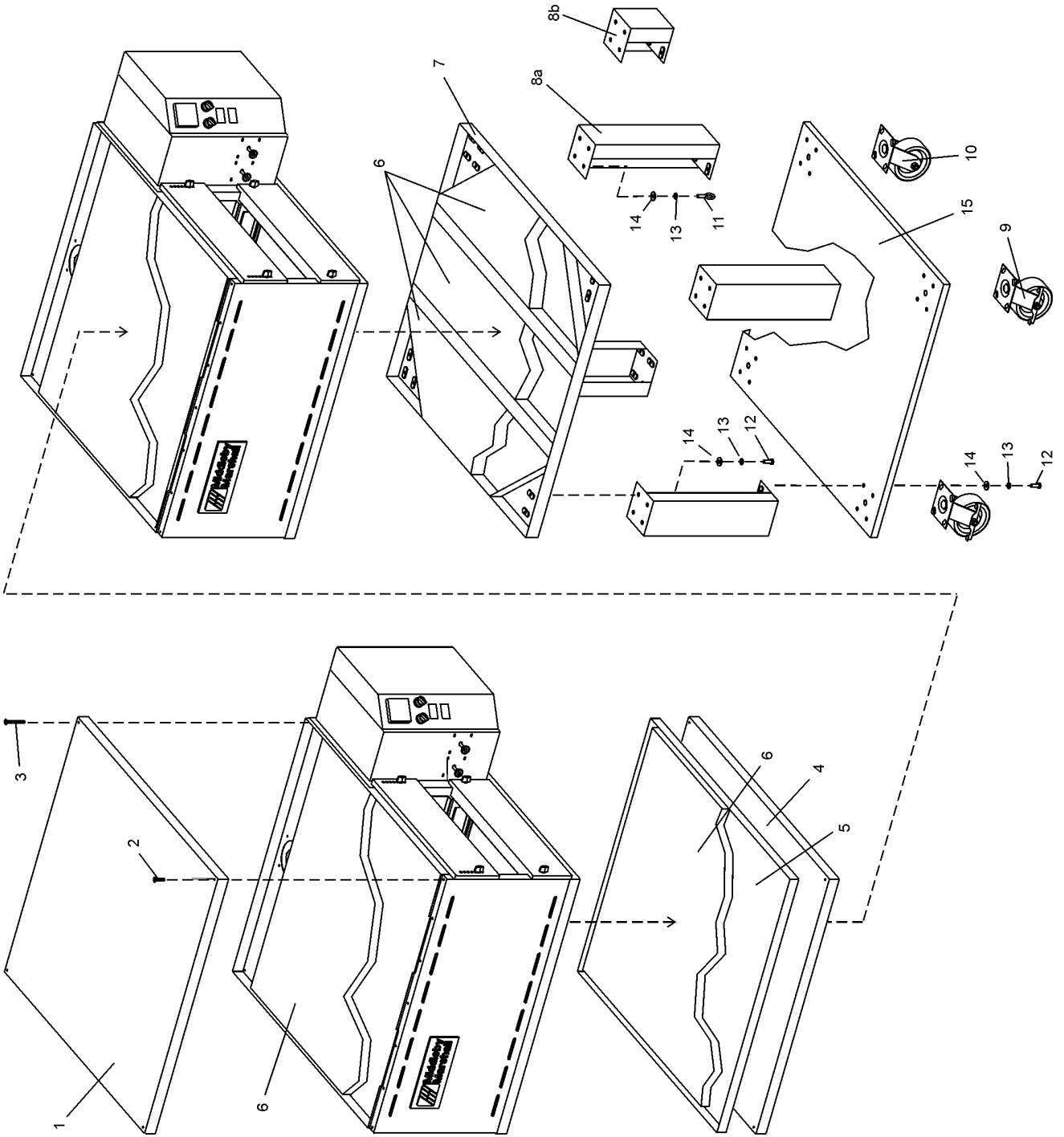

III. TOP PANEL, BASE PAD, LEGS AND STACKING COMPONENTS

ITEM QTY.	P/N	DESCRIPTION
1 1	42882	TOP PANEL
2 2	220352	SCREW, PAN HEAD #10 X 1"
3 2	3A80A8801	SCREW, PAN HEAD #10 X 2"
4 1	42882	TOP PANEL
5 1	44837	STACKING PANEL
6 A/R	--	INSULATION, 1-1/2" THICK
7 1	42893	BASE PAD
8a 4	42890	17-1/2" (445mm) LEG EXTENSION (STANDARD), SINGLE & DOUBLE OVENS
8b 4	44799	6" (152mm) LEG EXTENSION (STANDARD), TRIPLE OVENS
8c 4	45329	23-1/2" (597mm) LEG EXTENSION (CUSTOM), SINGLE OVENS
8d 4	45360	20-1/2" (521mm) LEG EXTENSION (CUSTOM), SINGLE OVENS
9 2	22290-0009	CASTER, WITH MOUNTING PLATE AND BRAKE
10 2	22290-0010	CASTER, WITH MOUNTING PLATE (NO BRAKE)
11 1	21392-0004	EYE BOLT, 3/4"
12 31	220373	HEX BOLT, 3/8"-16 X 1"
13 32	21416-0001	FLAT WASHER, 3/8"
14 32	21422-0001	LOCKWASHER, 3/8"
15 1	46393	LOWER SHELF (OPTIONAL)

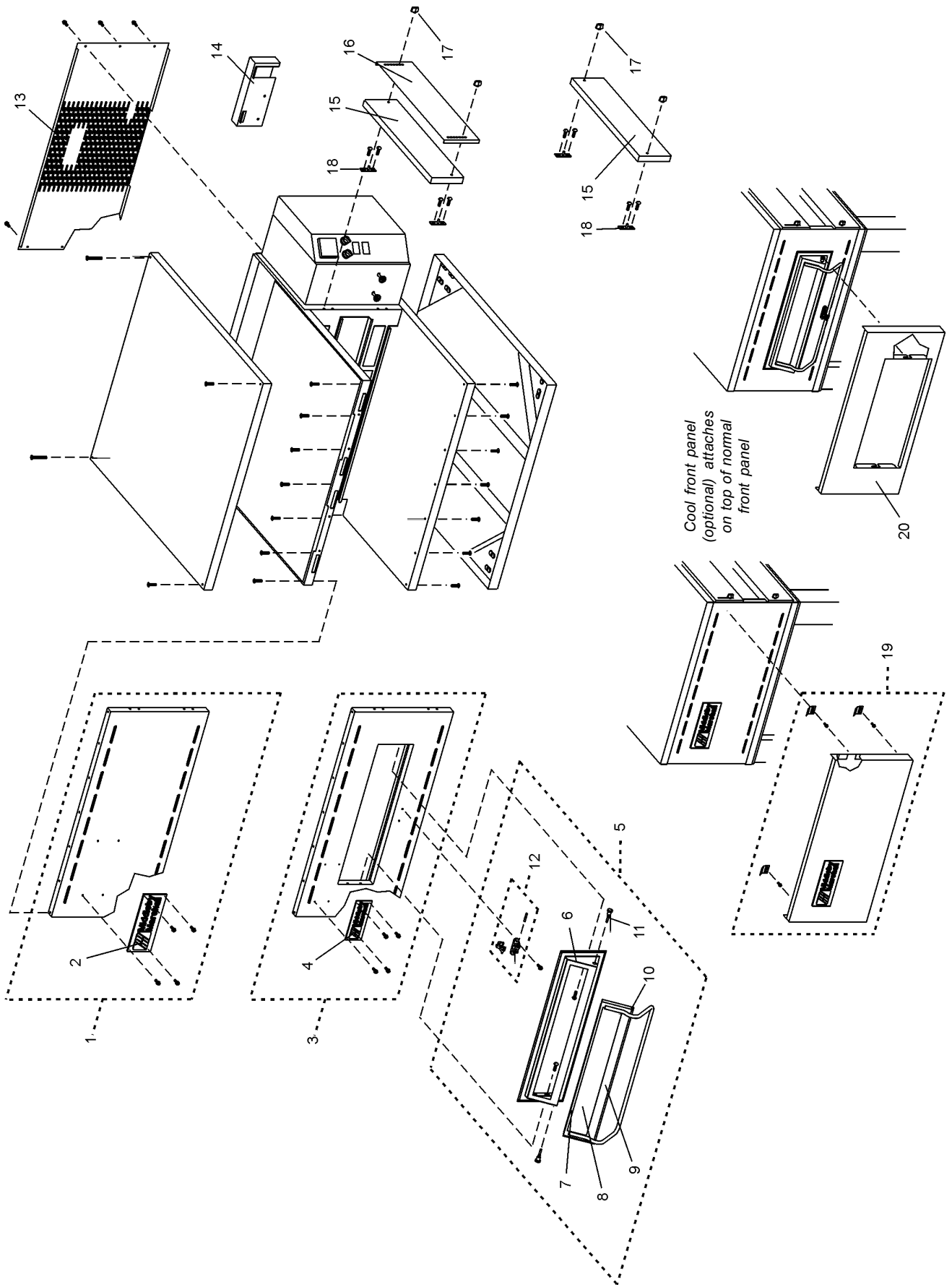

IV. PANELS, END PLUGS, WINDOW AND COOL FRONT

ITEM QTY.	P/N	DESCRIPTION
1 1	43255	ASSEMBLY, FRONT PANEL WITHOUT WINDOW (INC. ITEM 2)
2 1	22500-0021	NAMEPLATE, "MIDDLEBY MARSHALL" (STANDARD SIZE)
3 1	44803	ASSEMBLY, FRONT PANEL WITH WINDOW (INC. ITEMS 4-12)
4 1	45739	NAMEPLATE, "MIDDLEBY MARSHALL" (SMALL SIZE)
5 1	49400-0120	ASSEMBLY, WINDOW AND LATCH (INC. ITEMS 6-12)
6 1	37900-0103	WINDOW MOUNTING FRAME
7 1	30286	WINDOW FRAME TOP
8 1	22140-0017	GLASS, PRE-CUT
9 1	30287	WINDOW FRAME
10 1	33300-0273	HINGE TUBE
11 2	34121-0003	THUMBSCREW, PIVOT
12 1	42400-0087	ASSEMBLY, LATCH
13 1	46568	REAR PANEL
14 1	See pp. 20-31	CHAIN COVER, UPPER
15 4	43252	END PLUG
16 2	42771	EYEBROW
17 8	36452	WING NUT, PLASTIC
18 8	45449	BRACKET, END PLUG MOUNTING
19 A/R	47217	KIT, COOL FRONT PANEL WITHOUT WINDOW (INC. BRACKETS AND HARDWARE)
20 A/R	44471	COOL FRONT PANEL WITH WINDOW

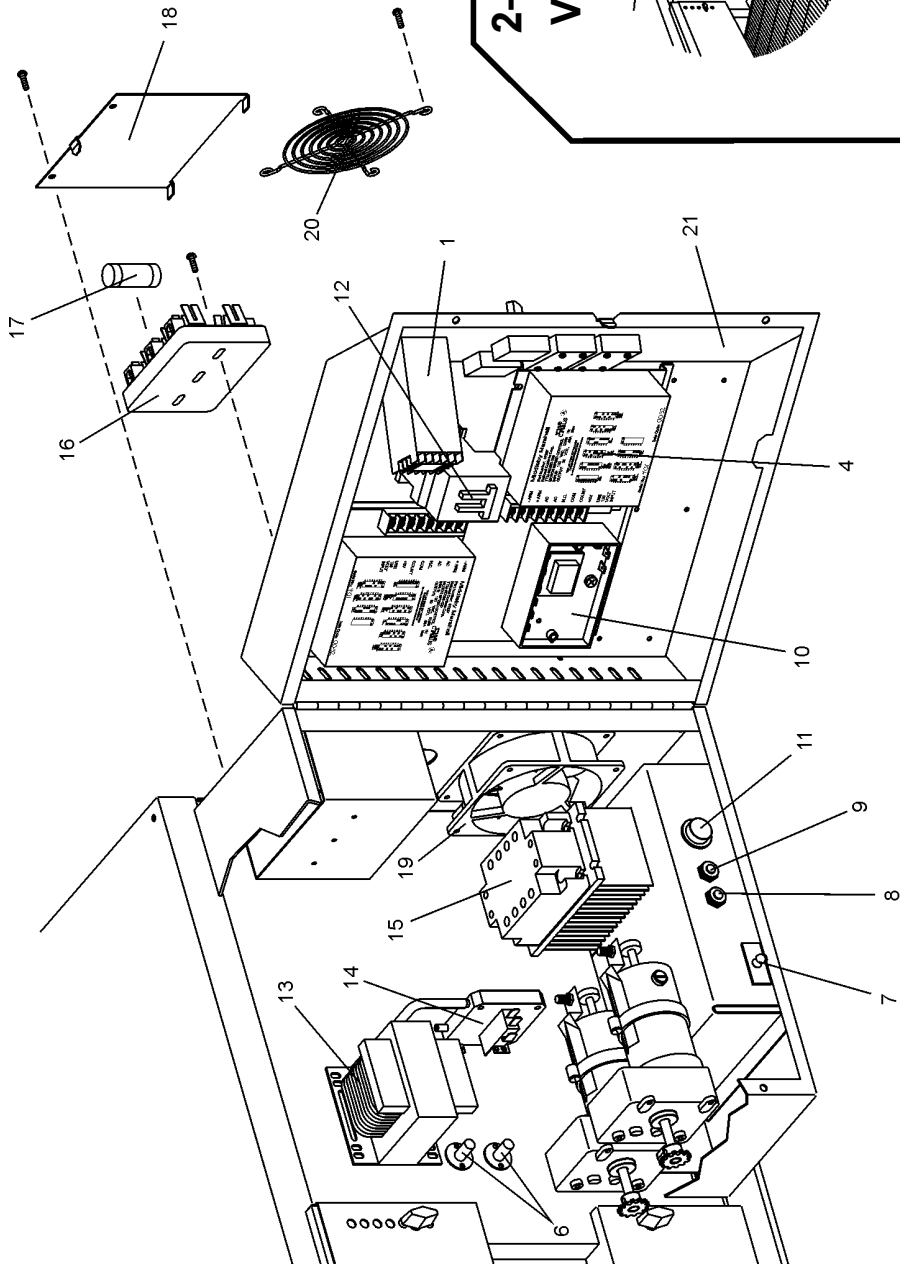

**2-SWITCH
VERSION**

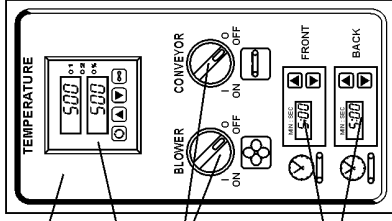
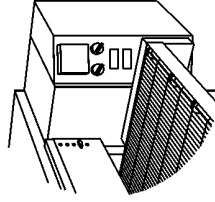

**3-SWITCH
VERSION**

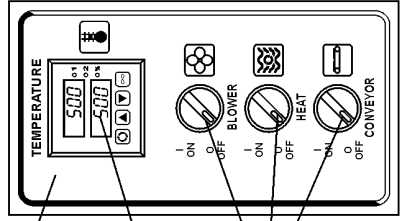
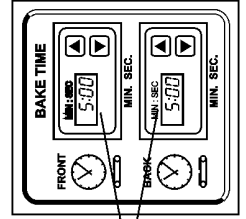
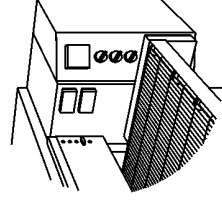

V. CONTROL COMPARTMENT FOR ELECTRIC OVENS

ITEM QTY.	P/N	DESCRIPTION	ITEM QTY.	P/N	DESCRIPTION
1	1	44783	1	28041-0008	DIGITAL TEMPERATURE CONTROLLER (FOR ELECTRIC OVENS)
2	APR	37168	1	31504	SELECTOR SWITCH WITH KNOB
3a	1	43346	1	39530	DECAL, CONTROL PANEL, 3-SWITCH VERSION
3b	1	45333	1	44585	DECAL, CONTROL PANEL, 2-SWITCH VERSION
4	APR	37337	1	27021-0016	KIT, CONVEYOR SPEED CONTROLLER WITH DIGITAL DISPLAY (INC. ITEM 5)
5	APR	37503	3	44701	DIGITAL DISPLAY
6	2	33985	1	42847	KIT, THERMOCOUPLE
7	1	28021-0047	1	97525	SAFETY SWITCH
8	1	45036	1	27392-0002	CIRCUIT BREAKER, 3A
9	1	45037	1	27470-0004	CIRCUIT BREAKER, 15A
10a	1	33983	1	45325	HIGH LIMIT CONTROL MODULE, 240V (208V AND 240V MODELS)
10b	1	34982	1	27392-0002	HIGH LIMIT CONTROL MODULE, 115V (460V MODELS ONLY)
11	1	30693	1	Not available	RESET SWITCH FOR HIGH LIMIT (USED WITH ALL MODELS)
12	1	28041-0008	1	28041-0008	CONTACTOR
13	1	31504	1	31504	TRANSFORMER, 230V PRI : 120V SEC, 200 VA (NOTE: TRANSFORMER IS CONNECTED 460V PRI : 120V SEC ON 460V ELECTRIC OVENS)
14	1	39530	1	39530	AIR SWITCH
15	1	44585	1	44585	ASSEMBLY, SOLID STATE RELAY AND HEAT SINK
16	1	27021-0016	1	27021-0016	FUSE BLOCK
17	3	44701	3	44701	FUSE, 60A
18	1	42847	1	42847	COVER, ELECTRICAL JUNCTION BOX
19a	1	97525	1	97525	AXIAL COOLING FAN, 230V (208V AND 240V MODELS)
19b	1	27392-0002	1	27392-0002	AXIAL COOLING FAN, 115V (460V MODELS ONLY)
20	1	27470-0004	1	27470-0004	GUARD, COOLING FAN
21a	1	45325	1	45325	CONTROL PANEL, 2-SWITCH CONFIGURATION, FOR ELECTRIC OVENS WITH RIGHT-SIDE CONTROLS ONLY
21b	1	Not available	1	Not available	CONTROL PANEL, 2-SWITCH CONFIGURATION, FOR ELECTRIC OVENS WITH LEFT-SIDE CONTROLS ONLY

See pp. 16-17
for gas train
components

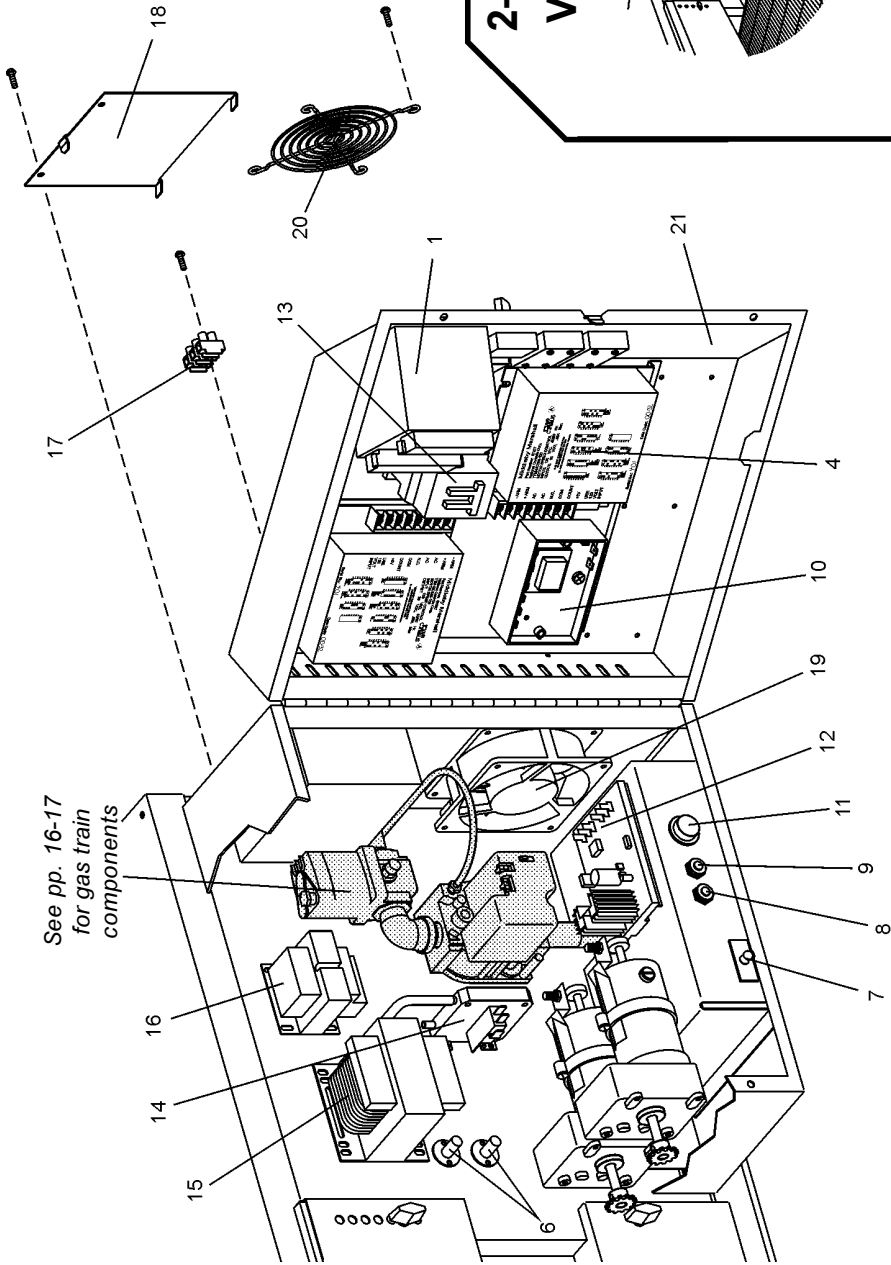

**2-SWITCH
VERSION**

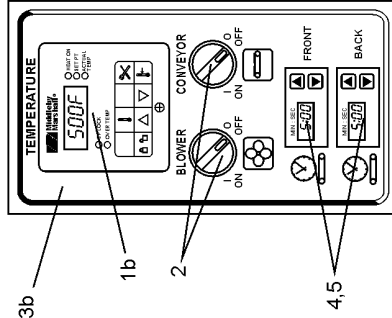
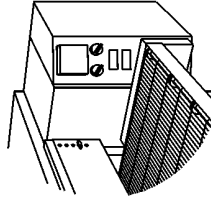

**3-SWITCH
VERSION**

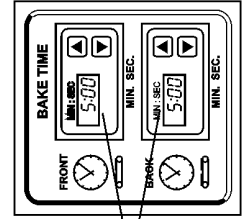
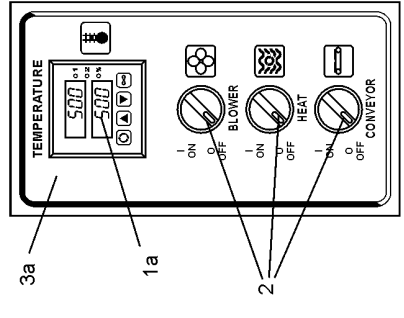
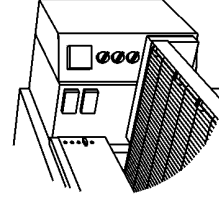

VI. CONTROL COMPARTMENT FOR GAS OVENS

ITEM QTY.	P/N	DESCRIPTION	ITEM QTY.	P/N	DESCRIPTION
1 1	44823	DIGITAL TEMPERATURE CONTROLLER (FOR GAS OVENS - INCLUDED THROUGH 2/01)	10 1	33983	HIGH LIMIT CONTROL MODULE, 240V
1 1	36939	DIGITAL TEMPERATURE CONTROLLER (INCLUDED 3/01 - CURRENT)	11 1	30693	RESET SWITCH FOR HIGH LIMIT, LIGHTED
2 3	37168	SELECTOR SWITCH WITH KNOB	12 1	31651	AMPLIFIER BOARD
3a 1	43346	DECAL, CONTROL PANEL, 3-SWITCH VERSION	13 1	28041-0008	CONTACTOR
3b 1	45333	DECAL, CONTROL PANEL, 2-SWITCH VERSION	14 1	39530	AIR SWITCH
4 A/R	37337	KIT, CONVEYOR SPEED CONTROLLER WITH DIGITAL DISPLAY (INC. ITEM 5)	15 1	31504	TRANSFORMER, 230V PRI : 120V SEC, 200 VA
5 A/R	37503	DIGITAL DISPLAY	16 1	32108	TRANSFORMER, 230V PRI : 24V SEC, 65 VA
6 2	33985	KIT, THERMOCOUPLE	17 1	33406	TERMINAL BLOCK, 3-POLE
7 1	28021-0047	SAFETY SWITCH	18 1	42847	COVER, ELECTRICAL JUNCTION BOX
8 1	45036	CIRCUIT BREAKER, 3A	19a 1	97525	AXIAL COOLING FAN, 230V
9 1	45037	CIRCUIT BREAKER, 15A	21a 1	45325	CONTROL PANEL, 2-SWITCH CONFIGURATION, FOR GAS OVENS WITH RIGHT-SIDE CONTROLS ONLY
			21b 1	45155	CONTROL PANEL, 2-SWITCH CONFIGURATION, FOR GAS OVENS WITH LEFT-SIDE CONTROLS ONLY

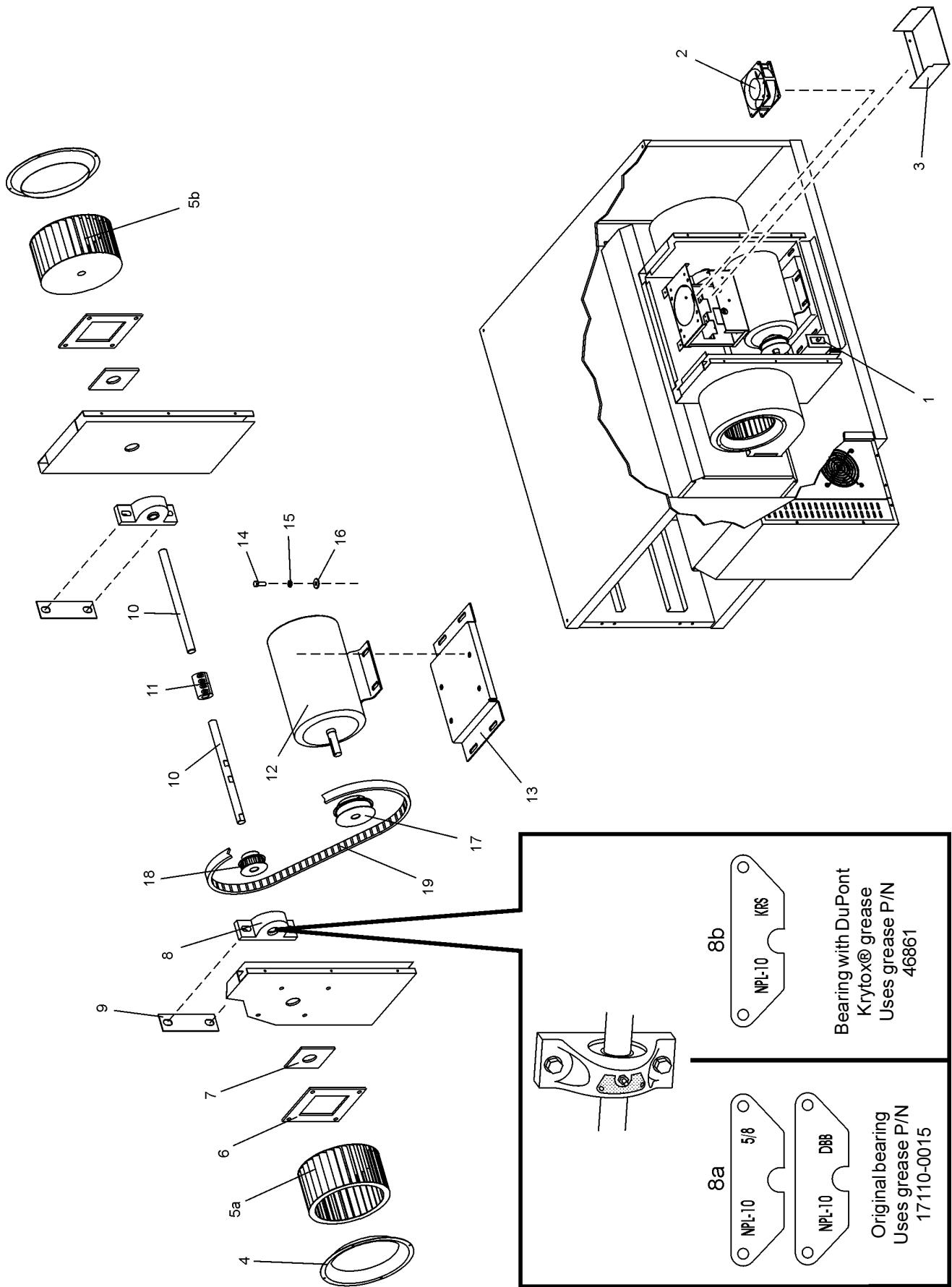

VII. BLOWER ASSEMBLY

ITEM QTY.	PIN	DESCRIPTION	ITEM QTY.	PIN	DESCRIPTION
1	1	28021-0047 SAFETY SWITCH	9	2	46601 GASKET, BEARING (USED ON OVENS EQUIPPED WITH BEARING 8b)
2a	1	97525 AXIAL COOLING FAN, 230V	10	2	42760 BLOWER SHAFT
2b	1	27381-0001 AXIAL COOLING FAN, 115V (430V ELECTRIC OVENS ONLY)	11	1	44748 COUPLING, BLOWER SHAFT
3	1	46591 BAFFLE, COOLING FAN	12a	1	44687 MOTOR, BLOWER, 208/230V, 1/2HP
4	2	42951 INLET RING	12b	1	46907 MOTOR, BLOWER, 430V, 1/3 HP (430V ELECTRIC OVENS ONLY)
5a	1	42752 BLOWER WHEEL, RIGHT	13	1	44688 PLATE, MOTOR MOUNTING
5b	1	42753 BLOWER WHEEL, LEFT	14	4	A11687 SCREW, HEX CAP HEAD 5/16"-18 X 7/8"
6	2	42999 RETAINER, TEFLON SEAL	15	4	B301A8847 FLAT WASHER, 5/16"
7	2	35121-0045 TEFLON SEAL	16	4	A3682 LOCK WASHER, 5/16"
8a	2	22072-0025 BEARING, 5/8" BORE WITH STANDARD GREASE	17a	1	43111 PULLEY, BLOWER MOTOR, 24T
--	--	17110-0015 GREASE, MM STANDARD CARTRIDGE	18	1	42795 PULLEY, BLOWER SHAFT
8b	2	46537 BEARING, 5/8" BORE WITH DUPONT KRYTOX® GREASE	19	1	44685 BLOWER BELT
--	--	46861 GREASE, DUPONT KRYTOX®, 8 OZ. TUBE			

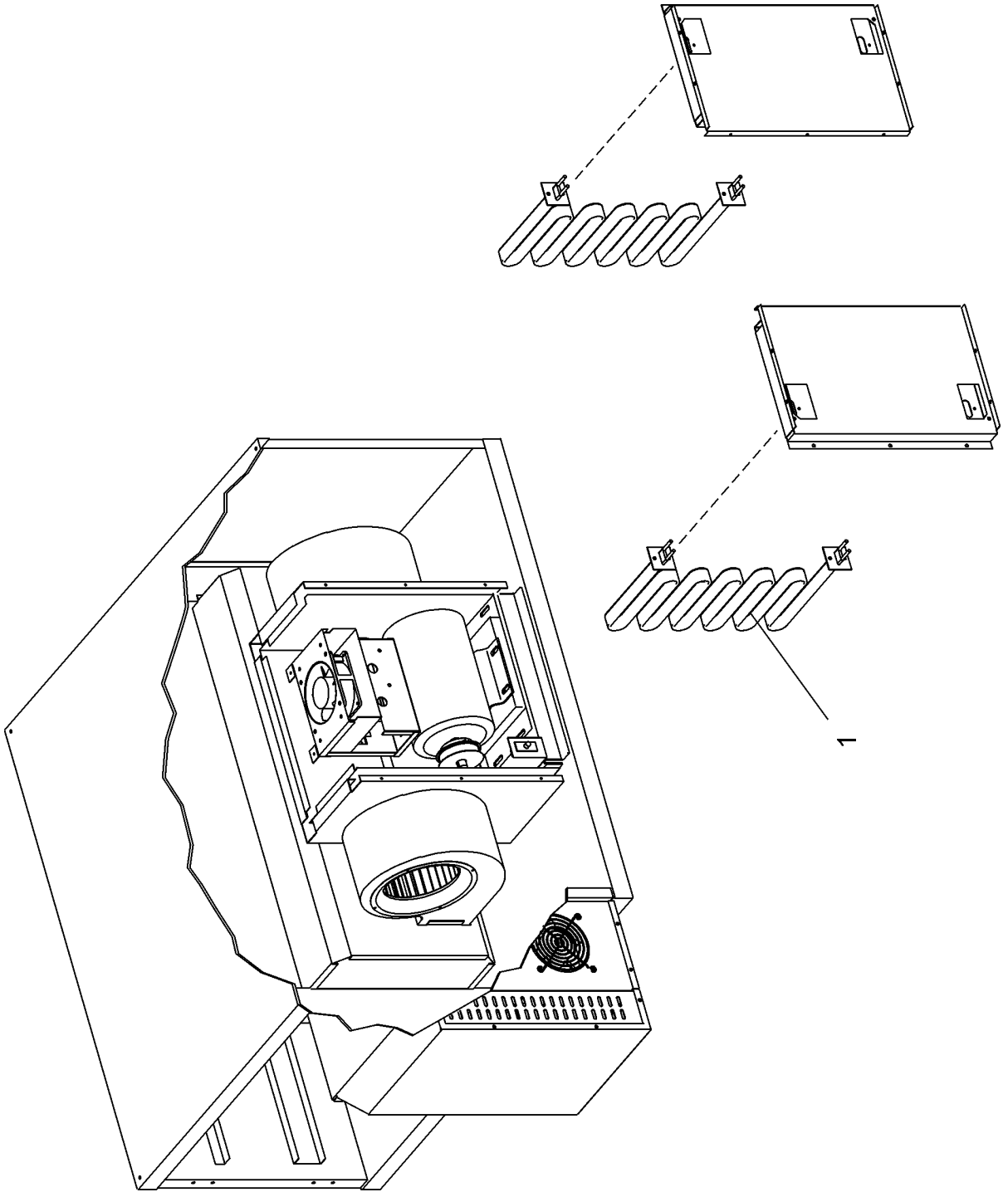

VIII. HEATING ELEMENTS

ITEM	QTY.	P/N	DESCRIPTION
1a	2	43094	HEATING ELEMENT, 208V, 8kW
1b	2	44800	HEATING ELEMENT, 230V, 8kW
1c	2	45281	HEATING ELEMENT, 380V, 8kw

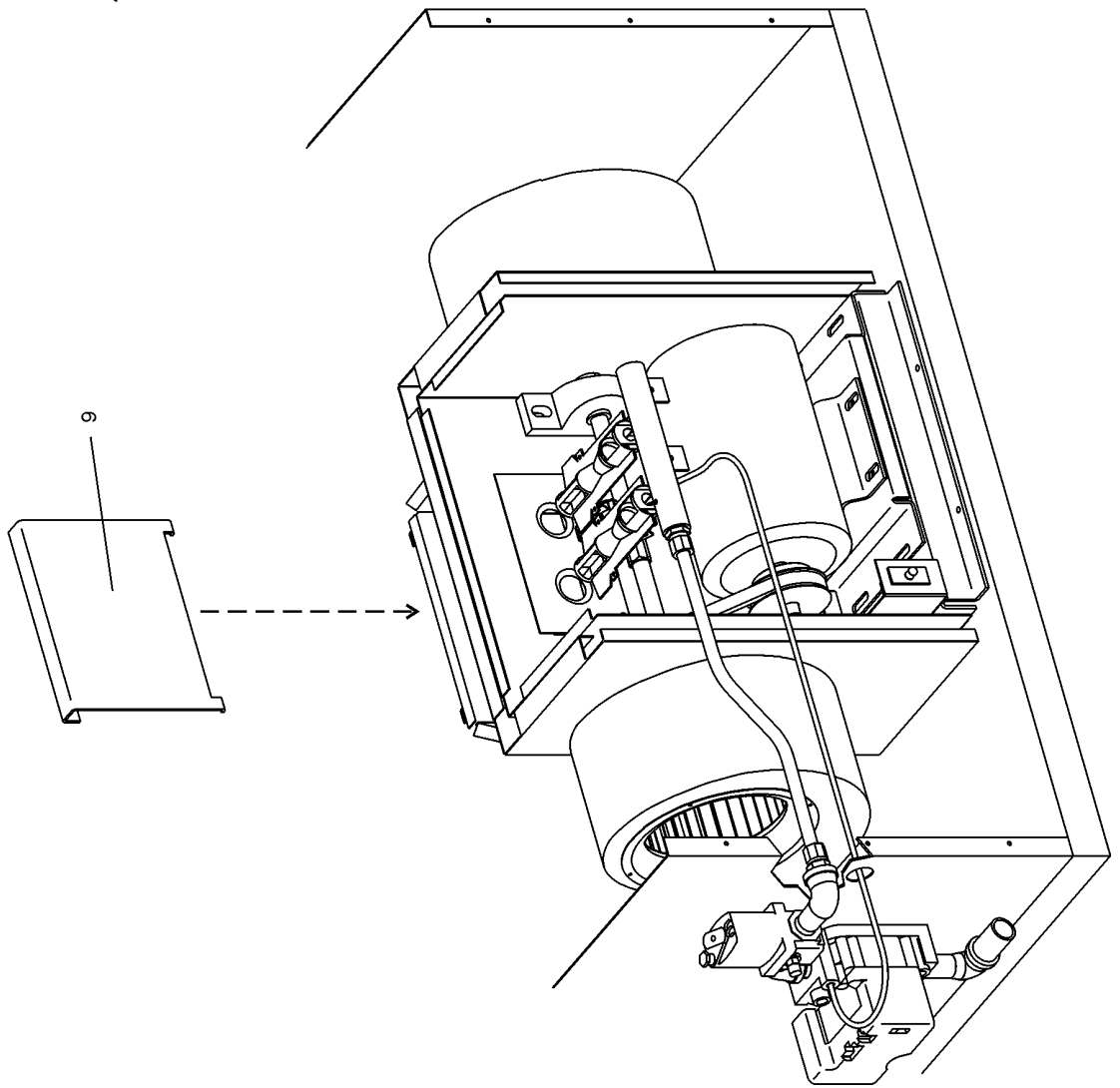
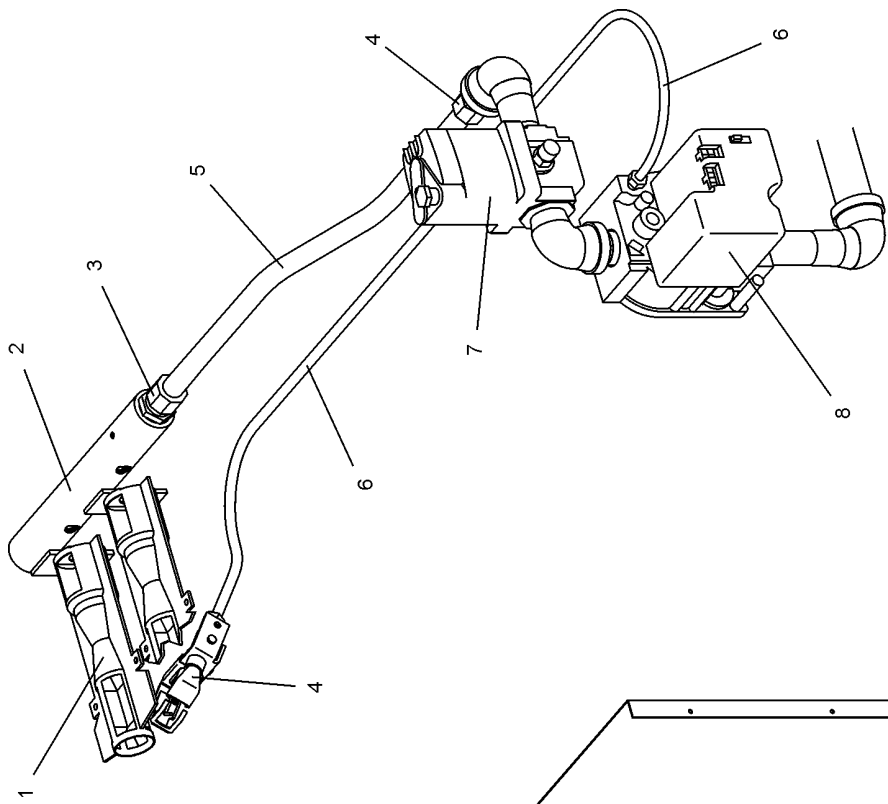

PS536
USA & Std. Export

IX. GAS TRAIN ASSEMBLY

ITEM QTY.	P/N	DESCRIPTION
1 2	44983	BURNER, INSHOT
2 1	45001	MANIFOLD ASSEMBLY
3 2	45043	BURNER TUBE FITTING, 1/2"
4 1	44982	PILOT ASSEMBLY
5 A/R	45245	TUBE, ALUMINUM, 1/2" (12.7mm) O.D. (BULK)
6 A/R	15125-0002	TUBE, ALUMINUM, 1/4" (6.35mm) O.D. (BULK)
7 1	41647	MODULATING GAS VALVE, 1/2"
8 1	45003	COMBINATION GAS CONTROL VALVE
9 1	44492	PLATE, TARGET
NOT SHOWN:		
-- 2	44984	MAIN ORIFICE, NATURAL GAS, 0.935" (2.375mm, #42 DRILL)
-- 2	44985	MAIN ORIFICE, PROPANE, 0.055" (1.379mm, #54 DRILL)
-- 1	22174-0011	PILOT ORIFICE, NATURAL GAS, 0.028" (0.710mm)
-- 1	22174-0010	PILOT ORIFICE, PROPANE, 0.018" (0.460mm)

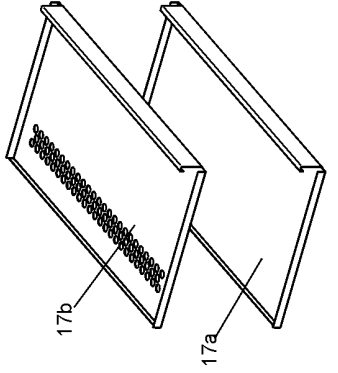
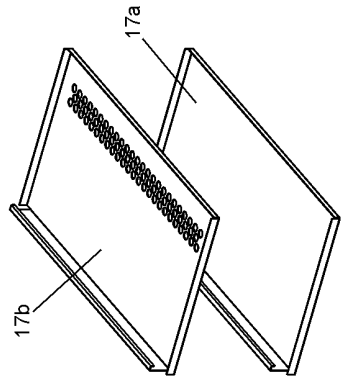
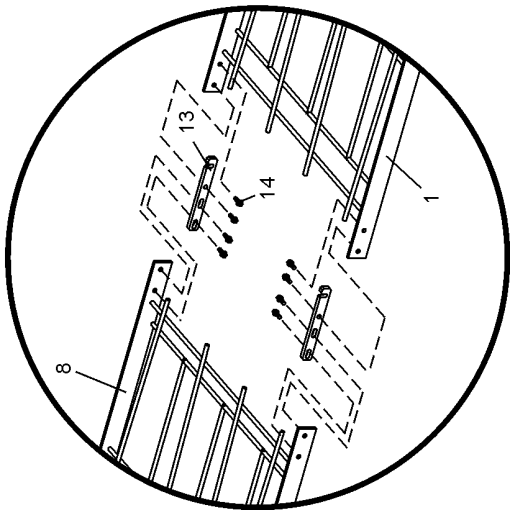
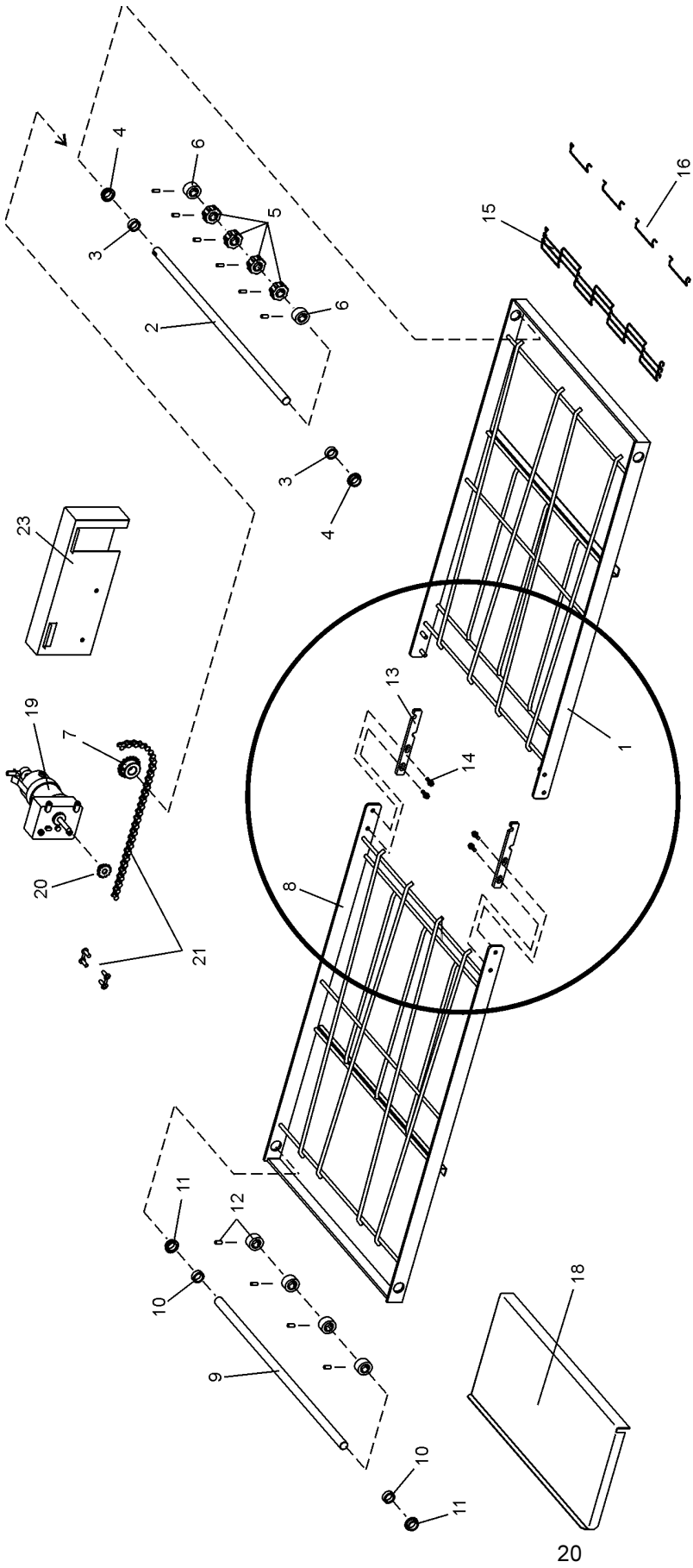

X. BAR-FRAME SINGLE-BELT CONVEYORS, 60"/1.52m (ORIGINAL STANDARD)

Original design produced through 3/01. 60" (1.52m) long, non-folding after initial assembly, center tension adjustment

Current design produced 4/01-current. 60" (1.52m) long, folding, center tension adjustment

ITEM QTY.	P/N		DESCRIPTION	P/N		DESCRIPTION
	Type 1	Type 2		Type 1	Type 2	
-- 1	--	--	CONVEYOR DRIVE SECTION	43009	45324	ADJUSTMENT BRACKET, CONVEYOR TENSION
1 1	44596	45317	CONVEYOR FRAME, DRIVE			
2 1	42815	42815	CONVEYOR DRIVE SHAFT	A6153	A6153	SCREW, HEX HEAD 1/4"-20 X 1/2"
3 2	43275	43275	SPACER	44690	44690	BELT, CONVEYOR (COMPLETE)
4 2	3100473	3100473	BUSHING, BRONZE, 3/4" OD X 5/8" ID	45642	45642	KIT, MASTER LINKS
5 4	324503	324503	SPROCKET, CONVEYOR BELT - SER- RATED, WITH SET SCREW	42899	42899	CRUMB TRAY, SOLID
6 2	325001	325001	SPROCKET, CONVEYOR BELT - SMOOTH-SURFACED, WITH SET SCREW	44807	44807	CRUMB TRAY, PERFORATED
7a 1	42819	42819	SPROCKET, CONVEYOR DRIVE, 20T (STANDARD-FOR USE WITH ITEM 20a)	43173	43173	CONVEYOR EXIT TRAY
7b 1	45015	45015	SPROCKET, CONVEYOR DRIVE, 16T (HIGH SPEED OPTION-FOR USE WITH ITEM 20b)	44695	44695	ASSEMBLY, CONVEYOR DRIVE MOTOR AND PICKUP
-- 1	--	--	CONVEYOR IDLER SECTION			
8 1	44596	45316	CONVEYOR FRAME, IDLER	34129	34129	SPROCKET, CONVEYOR DRIVE MOTOR, 12T (STANDARD - FOR USE WITH ITEM 7a)
9 1	42814	42814	CONVEYOR IDLER SHAFT	45349	45349	SPROCKET, CONVEYOR DRIVE MOTOR, 25T (HIGH SPEED OPTION - FOR USE WITH ITEM 7b)
10 2	43275	43275	SPACER	44705	44705	ASSEMBLY, DRIVE CHAIN WITH MASTER LINK
11 2	3100473	3100473	BUSHING, BRONZE, 3/4" OD X 5/8" ID	45835	45835	CHAIN COVER, UPPER - OVENS WITH RIGHT-SIDE CONTROLS ONLY
12 4	325001	325001	SPROCKET, CONVEYOR BELT - SMOOTH-SURFACED, WITH SET SCREW	45311	45311	CHAIN COVER, UPPER - OVENS WITH LEFT-SIDE CONTROLS ONLY

PS536
USA & Std. Export

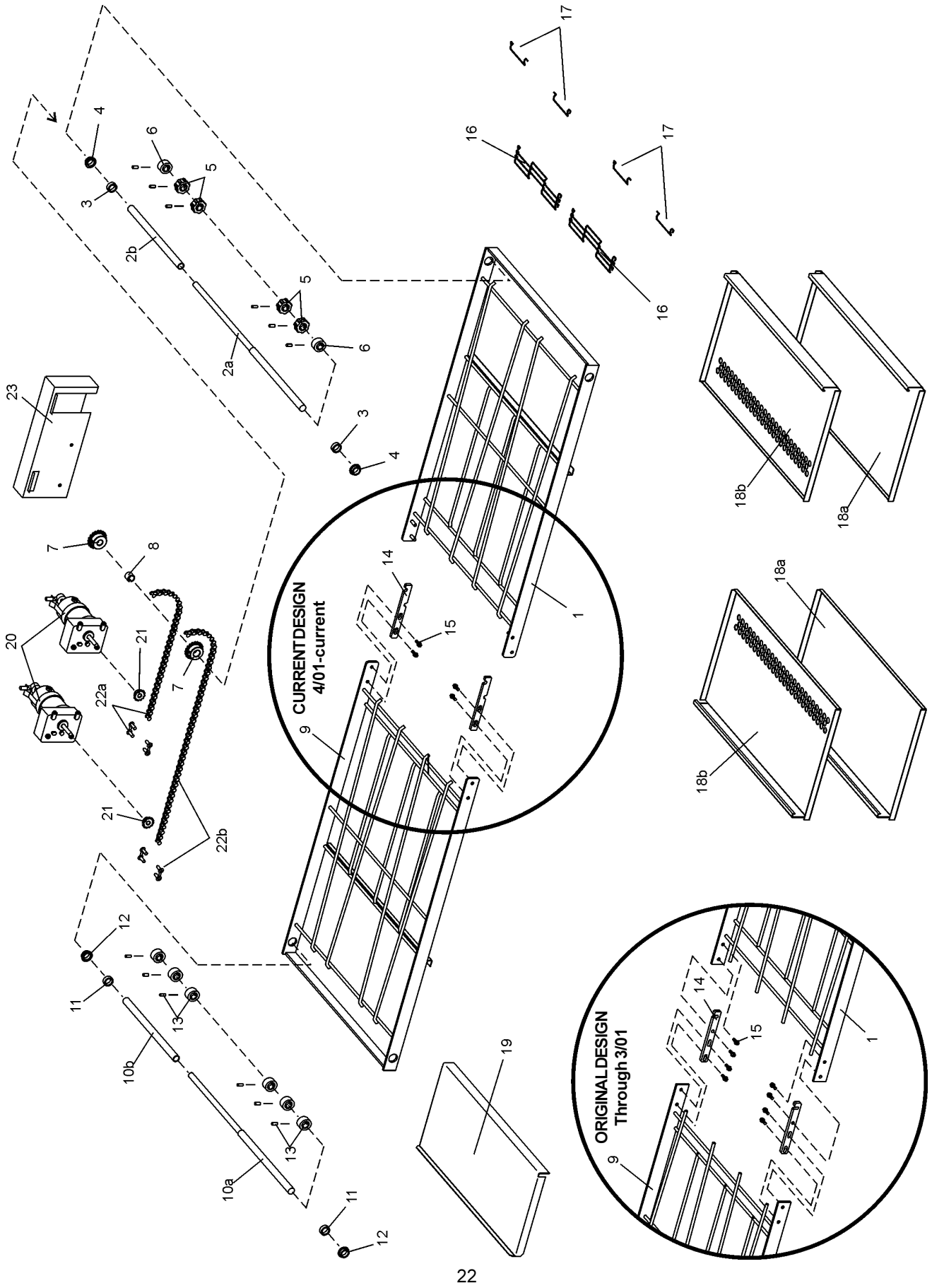

XI. BAR-FRAME SPLIT-BELT CONVEYORS, 60"/1.52m (ORIGINAL STANDARD)

Original design produced through 3/01. 60" (1.52m) long, non-folding after initial assembly, center tension adjustment
Current design produced 4/01-current. 60" (1.52m) long, folding, center tension adjustment

ITEM QTY.	P/N		DESCRIPTION	ITEM QTY.	P/N		DESCRIPTION	
	Type 1	Type 2			Type 1	Type 2		
--	1	--	CONVEYOR DRIVE SECTION	14	2	43009	45324	ADJUSTMENT BRACKET, CONVEYOR TENSION
1	1	44596	CONVEYOR FRAME, DRIVE	15	AR	A6153	A6153	SCREW, HEX HEAD 1/4"-20 X 1/2"
2a	1	44990	CONVEYOR DRIVE SHAFT - FRONT	16	2	45352	45352	BELT, CONVEYOR (COMPLETE)
2b	1	45339	CONVEYOR DRIVE SHAFT - REAR	17	1	45642	45642	KIT, MASTER LINKS
3	2	43275	SPACER	18a	2	42899	42899	CRUMB TRAY, SOLID
4	2	3100473	BUSHING, BRONZE, 3/4" OD X 5/8" ID	18b	2	44807	44807	CRUMB TRAY, PERFORATED
5	4	324503	SPROCKET, CONVEYOR BELT - SER- RATED, WITH SET SCREW	19	1	43173	43173	CONVEYOR EXIT TRAY
6	2	325001	SPROCKET, CONVEYOR BELT - SMOOTH-SURFACED, WITH SET SCREW	20	2	44695	44695	ASSEMBLY, CONVEYOR DRIVE MOTOR AND PICKUP
7a	2	42819	SPROCKET, CONVEYOR DRIVE, 20T (STANDARD-FOR USE WITH ITEM 21a)	21a	2	34129	34129	SPROCKET, CONVEYOR DRIVE MOTOR, 12T (STANDARD - FOR USE WITH ITEM 7a)
7b	2	45015	SPROCKET, CONVEYOR DRIVE, 16T (HIGH SPEED OPTION-FOR USE WITH ITEM 21b)	21b	2	45349	45349	SPROCKET, CONVEYOR DRIVE MOTOR, 25T (HIGH SPEED OPTION - FOR USE WITH ITEM 7b)
8	1	45337	SPACER RING, OUTSIDE SPROCKET CONVEYOR IDLER SECTION	22	2	44705	44705	ASSEMBLY, DRIVE CHAIN WITH MASTER LINK
--	1	--	CONVEYOR FRAME, IDLER	23a	1	45835	45835	CHAIN COVER, UPPER - OVENS WITH RIGHT-SIDE CONTROLS ONLY
9	1	44596	CONVEYOR FRAME, IDLER	23b	1	45311	45311	CHAIN COVER, UPPER - OVENS WITH LEFT-SIDE CONTROLS ONLY
10a	1	45353	CONVEYOR IDLER SHAFT - FRONT					
10b	1	43111	CONVEYOR IDLER SHAFT - REAR					
11	2	43275	SPACER					
12	2	3100473	BUSHING, BRONZE, 3/4" OD X 5/8" ID					
13	6	325001	SPROCKET, CONVEYOR BELT - SMOOTH-SURFACED, WITH SET SCREW					

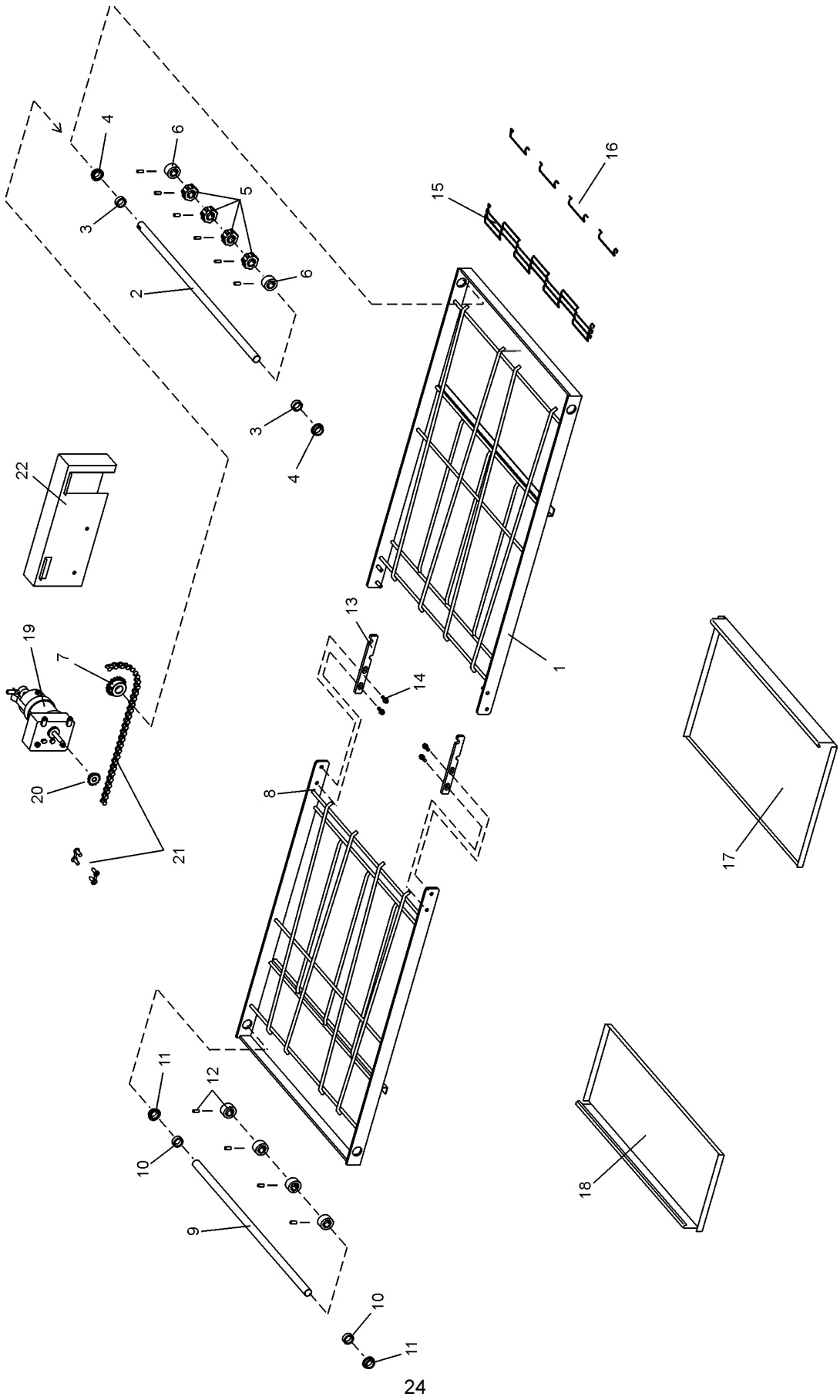

XII. BAR-FRAME SINGLE-BELT CONVEYOR, 56"/1.42m (PIZZA HUT)

Produced 10/01-current. 56" (1.42m) long, folding, center tension adjustment

ITEM QTY.	PIN	DESCRIPTION	Type 2	ITEM QTY.	PIN	DESCRIPTION	Type 1	Type 2
--	1	--	CONVEYOR DRIVE SECTION	13	2	45324	ADJUSTMENT BRACKET, CONVEYOR TENSION	
1	1	45317	CONVEYOR FRAME, DRIVE	14	AVR	A6153	SCREW, HEX HEAD 1/4"-20 X 1/2"	
2	1	42815	CONVEYOR DRIVE SHAFT	15	1	44690	BELT, CONVEYOR (COMPLETE)	
3	2	43275	SPACER	16	1	45642	KIT, MASTER LINKS	
4	2	3100473	BUSHING, BRONZE, 3/4" OD X 5/8" ID	17	1	42899	CRUMB TRAY (SOLID), DRIVE END	
5	4	324503	SPROCKET, CONVEYOR BELT - SERIALIZED, WITH SET SCREW	18	1	46484	CRUMB TRAY (SOLID), IDLER END	
6	2	325001	SPROCKET, CONVEYOR BELT - SMOOTH-SURFACED, WITH SET SCREW	19	1	44695	ASSEMBLY, CONVEYOR DRIVE MOTOR AND PICKUP	
7	1	42819	SPROCKET, CONVEYOR DRIVE, 20T	20	1	34129	SPROCKET, CONVEYOR DRIVE MOTOR, 12T	
--	1	--	CONVEYOR IDLER SECTION	21	1	44705	ASSEMBLY, DRIVE CHAIN WITH MASTER LINK	
8	1	46483	CONVEYOR FRAME, IDLER	22a	1	45835	CHAIN COVER, UPPER - OVENS WITH RIGHT-SIDE CONTROLS ONLY	
9	1	42814	CONVEYOR IDLER SHAFT	22b	1	45311	CHAIN COVER, UPPER - OVENS WITH LEFT-SIDE CONTROLS ONLY	
10	2	43275	SPACER					
11	2	3100473	BUSHING, BRONZE, 3/4" OD X 5/8" ID					
12	4	325001	SPROCKET, CONVEYOR BELT - SMOOTH-SURFACED, WITH SET SCREW					

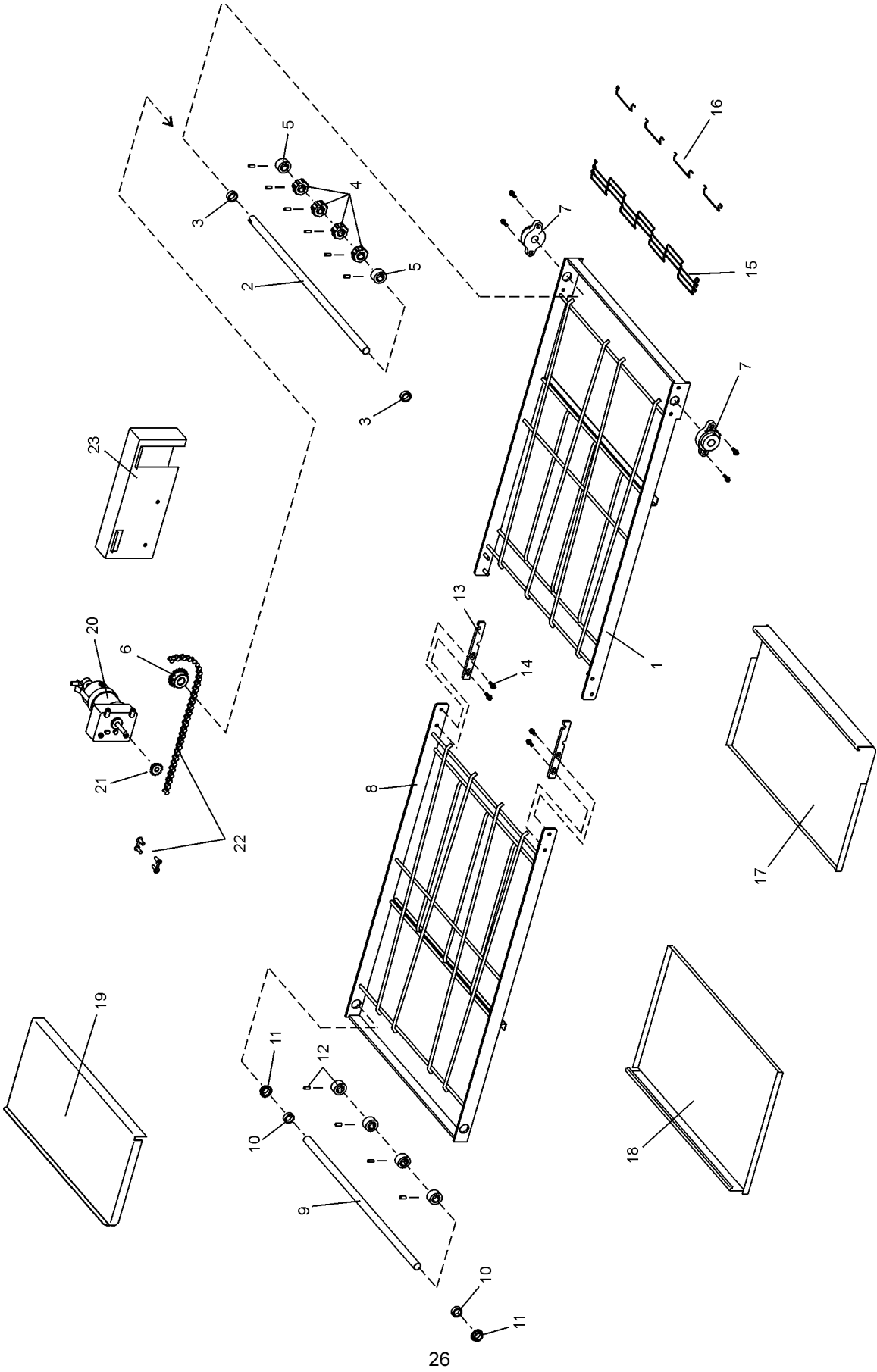

XIII. BAR-FRAME SINGLE-BELT CONVEYOR, 60"/1.52m, WITH EXTERNAL BEARINGS (SCHLOTZSKY'S DELI)

Produced 3/01-current. 60" (1.52m) long, folding, center tension adjustment, external bearings

ITEM QTY.	P/N	DESCRIPTION	ITEM QTY.	P/N	DESCRIPTION		
--	1	CONVEYOR DRIVE SECTION	13	2	45324	ADJUSTMENT BRACKET, CONVEYOR TENSION	
1	1	45378	CONVEYOR FRAME, DRIVE	14	A/R	A6153	SCREW, HEX HEAD 1/4"-20 X 1/2"
2	1	45375	CONVEYOR DRIVE SHAFT	15	1	44690	BELT, CONVEYOR (COMPLETE)
3	2	43275	SPACER	16	1	45642	KIT, MASTER LINKS
4	4	324503	SPROCKET, CONVEYOR BELT - SERIALIZED, WITH SET SCREW	17	2	45376	CRUMB TRAY (SOLID), DRIVE END
5	2	325001	SPROCKET, CONVEYOR BELT - SMOOTH-SURFACED, WITH SET SCREW	18	1	42899	CRUMB TRAY (SOLID), IDLER END
6	1	45015	SPROCKET, CONVEYOR DRIVE, 16T	19	1	43173	CONVEYOR EXIT TRAY
7	2	45377	BEARING	20	1	44695	ASSEMBLY, CONVEYOR DRIVE MOTOR AND PICKUP
--	1	CONVEYOR IDLER SECTION	21	1	45349	SPROCKET, CONVEYOR DRIVE MOTOR, 25T	
8	1	45316	CONVEYOR FRAME, IDLER	22	1	44705	ASSEMBLY, DRIVE CHAIN WITH MASTER LINK
9	1	42814	CONVEYOR IDLER SHAFT	23a	1	45643	CHAIN COVER, UPPER - OVENS WITH RIGHT-SIDE CONTROLS ONLY
10	2	43275	SPACER	23b	1	Not available	CHAIN COVER, UPPER - OVENS WITH LEFT-SIDE CONTROLS ONLY
11	2	3100473	BUSHING, BRONZE, 3/4" OD X 5/8" ID				
12	4	325001	SPROCKET, CONVEYOR BELT - SMOOTH-SURFACED, WITH SET SCREW				

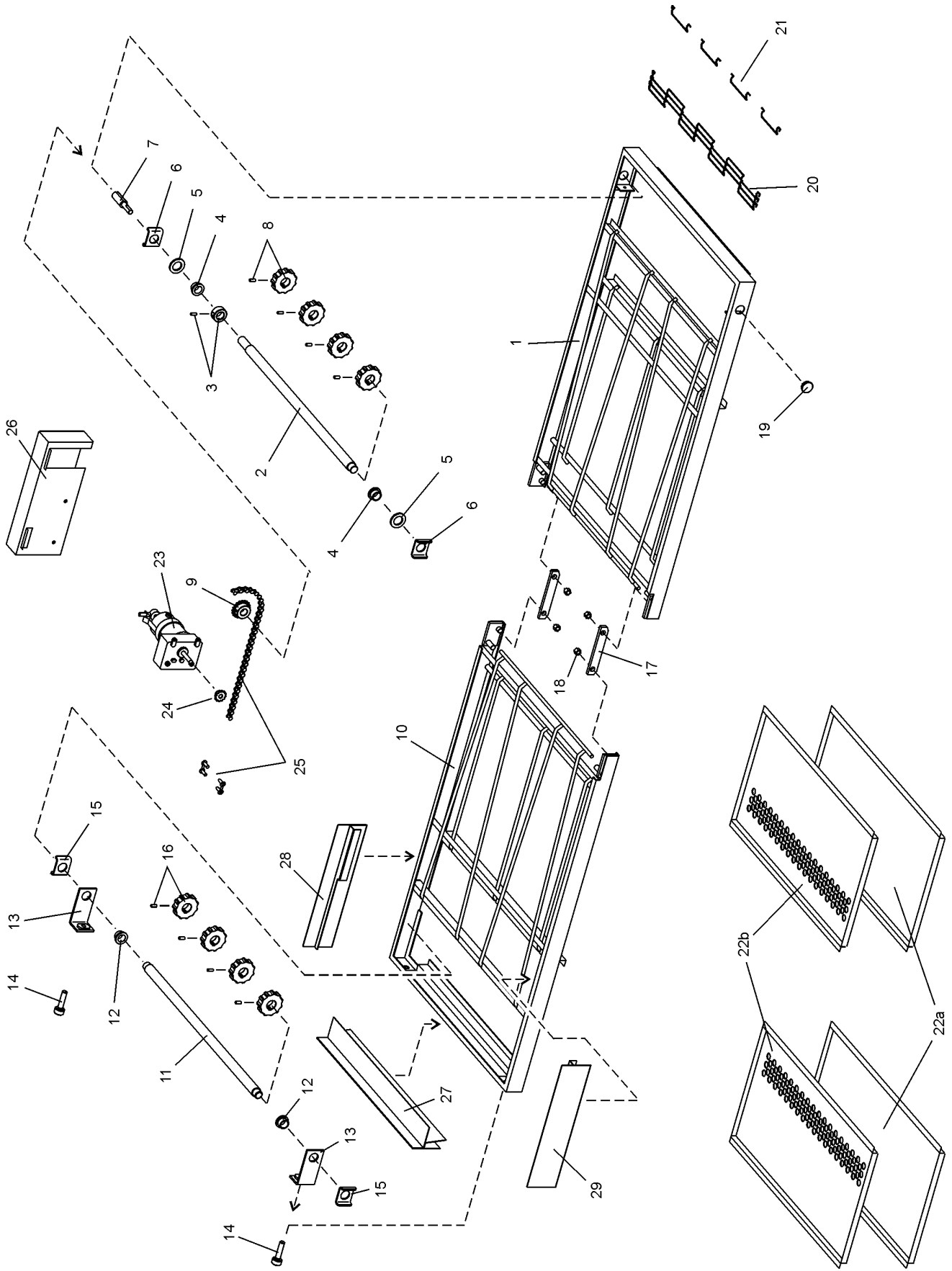

XIV. "C" CHANNEL-FRAME SINGLE-BELT CONVEYOR, 60"/1.52m (OLIVE GARDEN OR CURRENT STANDARD)

Produced 4/01-current. 60" (1.52m) long, folding, endplate thumbscrew tension adjustment

ITEM QTY.	PIN	DESCRIPTION	ITEM QTY.	PIN	DESCRIPTION
--	1	CONVEYOR DRIVE SECTION	17	2	PIVOT PLATE
1	45558	CONVEYOR FRAME, DRIVE	18	4	HEX LOCKNUT, 3/8"-16
2	45541	CONVEYOR DRIVE SHAFT	19	1	PLUG, 3/4"
3	22011-0013	COLLAR, SHAFT, WITH SET SCREW	20	1	BELT, CONVEYOR (COMPLETE)
4	22034-0003	BUSHING, FLANGED 3/4" OD x 5/8" ID	21	1	KIT, MASTER LINKS
5	35000-1080	SPACER, NYLON 1-1/4" OD x 3/4" ID	22a	2	CRUMB TRAY, SOLID
6	35900-0020	BRACKET, CONVEYOR SHAFT SUPPORT	22b	2	CRUMB TRAY, PERFORATED
7	35000-1013	ADAPTER, DRIVE SHAFT	23	1	ASSEMBLY, CONVEYOR DRIVE MOTOR AND PICKUP
8	22229-0003	SPROCKET, CONVEYOR BELT, WITH SET SCREW	24a	2	SPROCKET, CONVEYOR DRIVE MOTOR, 12T (STANDARD)
9	42819	SPROCKET, CONVEYOR DRIVE, 20T (STANDARD OR HIGH SPEED OPTION)	24b	2	SPROCKET, CONVEYOR DRIVE MOTOR, 20T (HIGH SPEED OPTION)
--	1	CONVEYOR IDLER SECTION	25	1	ASSEMBLY, DRIVE CHAIN WITH MASTER LINK
10	45559	CONVEYOR FRAME, IDLER	26a	1	CHAIN COVER, UPPER - OVENS WITH RIGHT-SIDE CONTROLS ONLY
11	45539	CONVEYOR IDLER SHAFT	26b	1	CHAIN COVER, UPPER - OVENS WITH LEFT-SIDE CONTROLS ONLY
12	22034-0003	BUSHING, FLANGED 3/4" OD x 5/8" ID	27	1	END STOP
13	37000-0413	BRACKET, IDLER TENSIONING	28	A/R	BACK STOP - LEFT END OR FRONT STOP - RIGHT END
14	35000-1008	SCREW, IDLER TENSIONING	29	A/R	BACK STOP - RIGHT END OR FRONT STOP - LEFT END
15	35900-0020	BRACKET, CONVEYOR SHAFT SUPPORT			
16	22229-0003	SPROCKET, CONVEYOR BELT, WITH SET SCREW			

PS536
USA & Std. Export

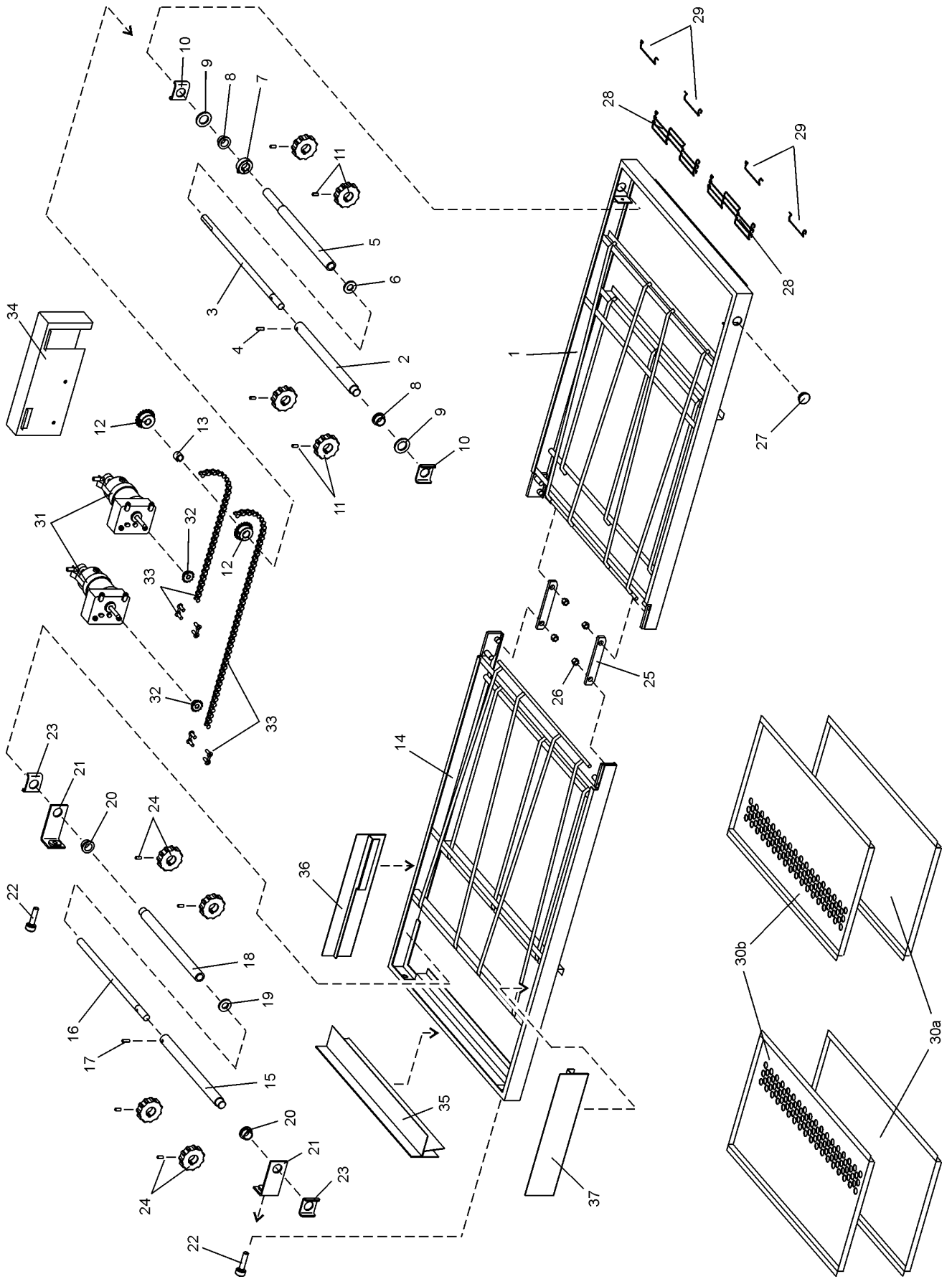

XV. "C" CHANNEL-FRAME SPLIT-BELT CONVEYOR, 60"/1.52m (CURRENT STANDARD)

Produced 1/02-current. 60" (1.52m) long, folding, endplate thumbscrew tension adjustment

ITEM QTY.	PIN	DESCRIPTION	ITEM QTY.	PIN	DESCRIPTION
--	1	CONVEYOR DRIVE SECTION	21	2	BRACKET, IDLER TENSIONING
1	45558	CONVEYOR FRAME, DRIVE	22	2	SCREW, IDLER TENSIONING
2	46698	CONVEYOR DRIVE SHAFT - FRONT	23	2	BRACKET, CONVEYOR SHAFT SUPPORT
3	46699	CONVEYOR DRIVE SHAFT - INNER SECTION	24	4	SPROCKET, CONVEYOR BELT, WITH SET SCREW
4	21646-0004	LOCKING PIN, 1/8" DIA. X 3/4" L	25	2	PIVOT PLATE
5	46702	CONVEYOR DRIVE SHAFT - REAR	26	4	HEX LOCKNUT, 3/8"-16
6	21415-0001	WASHER, BRONZE	27	1	PLUG, 3/4"
7	22011-0014	SPLIT SHAFT LOCKING COLLAR	28	2	BELT, CONVEYOR (COMPLETE)
8	22034-0003	BUSHING, FLANGED 3/4" OD X 5/8" ID	29	2	KIT, MASTER LINKS
9	35000-1080	SPACER, NYLON 1-1/4" OD X 3/4" ID	30a	2	CRUMB TRAY, SOLID
10	35900-0020	BRACKET, CONVEYOR SHAFT SUPPORT	30b	2	CRUMB TRAY, PERFORATED
11	22229-0003	SPROCKET, CONVEYOR BELT, WITH SET SCREW	31	2	ASSEMBLY, CONVEYOR DRIVE MOTOR AND PICKUP
12	42819	SPROCKET, CONVEYOR DRIVE, 20T (STANDARD OR HIGH SPEED OPTION)	32a	2	SPROCKET, CONVEYOR DRIVE MOTOR, 12T (STANDARD)
13	45337	SPACER RING, OUTSIDE SPROCKET CONVEYOR IDLER SECTION	32b	2	SPROCKET, CONVEYOR DRIVE MOTOR, 20T (HIGH SPEED OPTION)
14	45559	CONVEYOR FRAME, IDLER	33	2	ASSEMBLY, DRIVE CHAIN WITH MASTER LINK
15	46698	CONVEYOR IDLER SHAFT - FRONT	34a	1	CHAIN COVER, UPPER - OVENS WITH RIGHT-SIDE CONTROLS ONLY
16	46701	CONVEYOR IDLER SHAFT - INNER SECTION	34b	1	CHAIN COVER, UPPER - OVENS WITH LEFT-SIDE CONTROLS ONLY
17	21646-0004	LOCKING PIN, 1/8" DIA. X 3/4" L	35	1	END STOP
18	46700	CONVEYOR IDLER SHAFT - REAR	36	AVR	BACK STOP - LEFT END OR FRONT STOP - RIGHT END
19	21415-0001	WASHER, BRONZE	37	AVR	BACK STOP - RIGHT END OR FRONT STOP - LEFT END
20	22034-0003	BUSHING, FLANGED 3/4" OD X 5/8" ID			

PS536
USA & Std. Export

PS536
USA & Std. Export

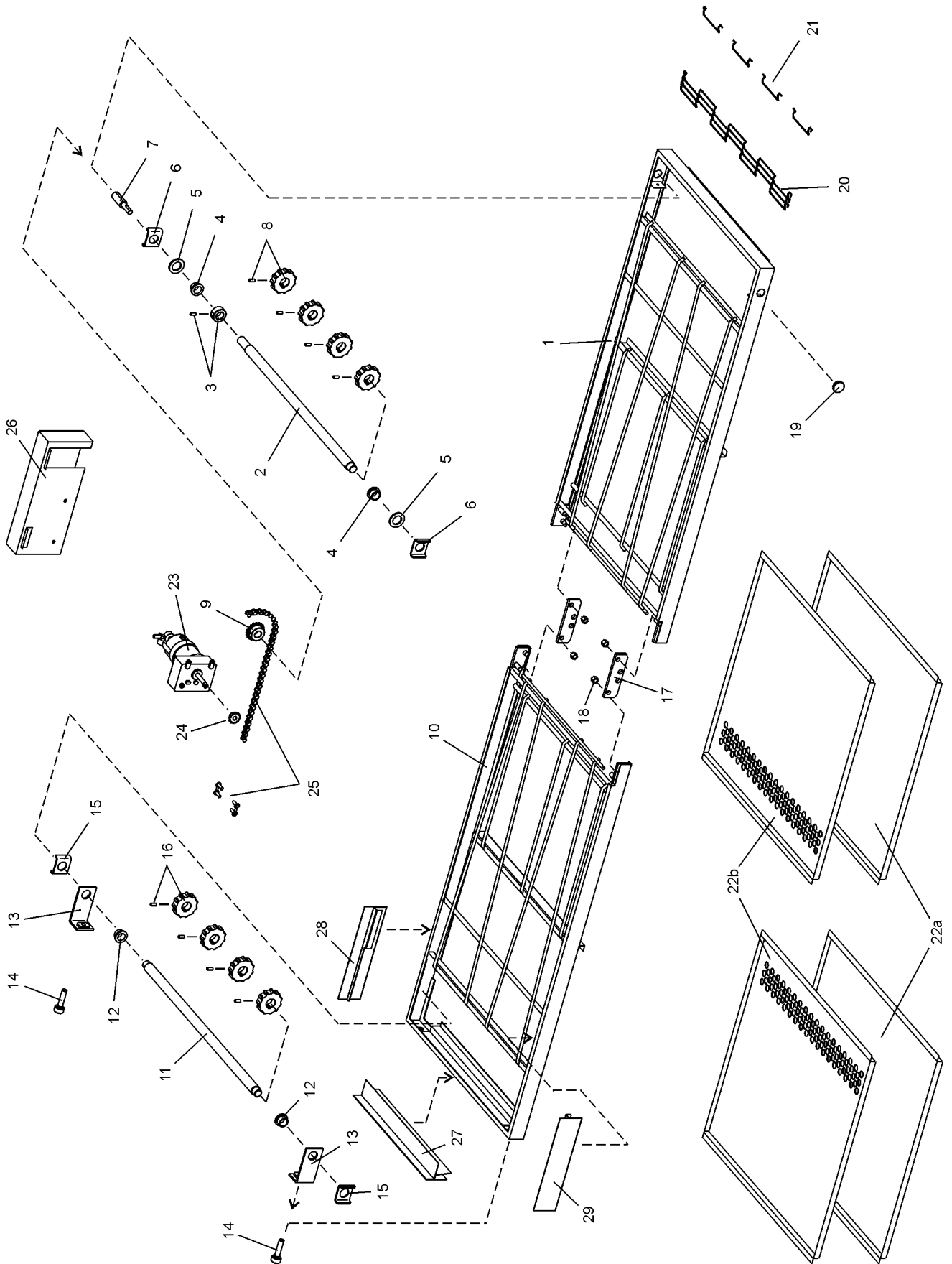

XIV. "C" CHANNEL-FRAME SINGLE-BELT CONVEYOR, 76"/1.93m (McDONALD'S OR 76" STANDARD)

Produced 4/01-current. 76" (1.93m) long, non-folding after assembly, endplate thumbscrew tension adjustment

ITEM QTY.	PIN	DESCRIPTION	ITEM QTY.	PIN	DESCRIPTION		
--	1	CONVEYOR DRIVE SECTION	17	2	45582	LOCKING PLATE	
1	1	45568	CONVEYOR FRAME, DRIVE	18	4	21176-0002	HEX LOCKNUT, 3/8"-16
2	1	45541	CONVEYOR DRIVE SHAFT	19	1	27413-0002	PLUG, 3/4"
3	2	22011-0013	COLLAR, SHAFT, WITH SET SCREW	20	1	45609	BELT, CONVEYOR (COMPLETE)
4	2	22034-0003	BUSHING, FLANGED 3/4" OD x 5/8" ID	21	1	45641	KIT, MASTER LINKS
5	2	35000-1080	SPACER, NYLON 1-1/4" OD x 3/4" ID	22a	2	45537	CRUMB TRAY, SOLID
6	2	35900-0020	BRACKET, CONVEYOR SHAFT SUPPORT	22b	2	47412	CRUMB TRAY, PERFORATED
7	1	35000-1013	ADAPTER, DRIVE SHAFT	23	1	44695	ASSEMBLY, CONVEYOR DRIVE MOTOR AND PICKUP
8	4	22229-0003	SPROCKET, CONVEYOR BELT, WITH SET SCREW	24	1	34129	SPROCKET, CONVEYOR DRIVE MOTOR, 12T
9	1	42819	SPROCKET, CONVEYOR DRIVE, 20T	25	1	45640	ASSEMBLY, DRIVE CHAIN WITH MASTER LINK
--	1	CONVEYOR IDLER SECTION	26a	1	45606	CHAIN COVER, UPPER - OVENS WITH RIGHT-SIDE CONTROLS ONLY	
10	1	45569	CONVEYOR FRAME, IDLER	26b	1	Not available	CHAIN COVER, UPPER - OVENS WITH LEFT-SIDE CONTROLS ONLY
11	1	45539	CONVEYOR IDLER SHAFT	27	1	46691	END STOP
12	2	22034-0003	BUSHING, FLANGED 3/4" OD x 5/8" ID	28	A/R	30830	BACK STOP - LEFT END OR FRONT STOP - RIGHT END
13	2	37000-0413	BRACKET, IDLER TENSIONING	29	A/R	30796	BACK STOP - RIGHT END OR FRONT STOP - LEFT END
14	2	35000-1008	SCREW, IDLER TENSIONING				
15	2	35900-0020	BRACKET, CONVEYOR SHAFT SUPPORT				
16	4	22229-0003	SPROCKET, CONVEYOR BELT, WITH SET SCREW				

WARNING

Improper installation, adjustment, alteration, service or maintenance can cause property damage, injury or death. Read the installation, operating and maintenance instructions thoroughly before installing or servicing this equipment.

NOTICE

During the warranty period, ALL parts replacement and servicing should be performed by your Middleby Marshall Authorized Service Agent. Service that is performed by parties other than your Middleby Marshall Authorized Service Agent may void your warranty.

NOTICE

Using any parts other than genuine Middleby Marshall factory manufactured parts relieves the manufacturer of all warranty and liability.

NOTICE

Middleby Marshall reserves the right to change specifications at any time.

PS536
USA & Std. Export

Middleby Cooking Systems Group • 1400 Toastmaster Drive • Elgin, IL 60120 • USA • (847)741-3300 • FAX (847)741-4406
24-Hour Service Hotline: 1-(800)-238-8444

www.middleby.com

