

MELITTA[®] CAFINA[®] CT8

Operating Instructions



1	General	4			
1.1	Manufacturer information	4			
1.2	About these instructions	4			
1.3	Explanation of symbols	4			
1.4	Description	4			
1.5	Accessories	5			
1.6	Conformity	5			
1.7	User interface	5			
2	Safety	5			
2.1	Intended use	5			
2.2	Safety information	6			
2.2.1	General	6			
2.2.2	Personnel	6			
2.2.3	Correct use	6			
3	Technical data	7			
4	Installation	8			
4.1	Prerequisites	8			
4.1.1	Water connection	8			
4.1.2	Electrical connection	8			
4.1.3	Installation location	8			
4.1.4	Product material	8			
4.2	Canister operation (option)	9			
4.2.1	Filling the fresh water canister	9			
4.2.2	Emptying the waste water canister	9			
5	Operation	10			
5.1	Chip keys	10			
5.1.1	Green user chip key	10			
5.1.2	Yellow manager chip key	10			
5.1.3	Without chip key	10			
5.1.4	Logging in with a chip key	10			
5.2	LED status indication	10			
5.3	Switching the machine on and off	11			
5.3.1	Switching on	11			
5.3.2	Stand-by operation	11			
5.3.3	Switching off	12			
5.4	Filling	13			
5.4.1	Filling the coffee supply	13			
5.4.2	Filling the instant powder (option)	14			
5.4.3	Filling the milk (option)	14			
5.5	Confirming filling levels	15			
5.6	Emptying the coffee grounds drawer	16			
5.7	Viewing the weekly planner	16			
5.8	Locking product dispensing	17			
5.9	System messages	17			
5.9.1	Messages in self-service operation	17			
5.9.2	Messages in waiter operation	17			
6	Dispensing products	18			
6.1	Product dispensing	18			
6.2	Canceling the product dispensing	18			
6.3	Dispensing coffee, coffee and milk, and milk products	19			
6.4	Dispensing hot water (option)	19			
6.5	Dispensing steam (option)	19			
6.5.1	Basic steam wand	19			
6.5.2	Steam wand with Steam Control Plus	20			
6.6	Dispensing milk foam via wand (option)	21			
6.7	Dispensing a double product	21			
6.8	Dispensing quick start products	22			
6.9	Dispensing multiplier products	22			
6.10	Multiple dispensing of a single product	22			
6.11	Batch mode	23			
6.12	Preparing coffee from ground coffee	24			
7	Settings	25			
7.1	Opening the manager menu	25			
7.2	Carrying out inputs	25			
7.3	Exiting the manager menu	25			
7.4	Menu option "Selection"	26			
7.4.1	Product groups	26			
7.4.2	Creating product groups	26			
7.4.3	Adding dispensing products	27			
7.4.4	Sorting the dispensing view	27			
7.4.5	Editing the dispensing view	27			
7.4.6	Delete displays	27			
7.5	Menu option "Product"	28			
7.5.1	Changing products	28			
7.5.2	Duplicating a product	28			
7.6	Menu option "Unit"	29			
7.6.1	Menu option "Filling levels"	29			
7.6.2	Menu option "Maintenance"	29			
7.6.3	Menu option "Weekly planner"	30			
7.7	Menu option "Operation"	31			
7.7.1	Opening usage statistics	31			
7.7.2	Opening product statistics	31			
7.7.3	Machine settings	32			
7.7.4	Logging	33			
8	Cleaning	33			
8.1	Safety measures	33			
8.2	Cleaning intervals	34			
8.3	Cleaning prompt and dispensing lock	34			
8.4	Cleaning agents	34			
8.5	When using canisters	35			
8.6	Cleaning the coffee grounds drawer	35			
8.7	Running the cleaning program	35			
8.7.1	Preparatory activities (option)	35			
8.7.2	Starting the cleaning program	36			
8.7.3	Cleaning the milk system (option)	36			
8.7.4	Cleaning the brewing system	38			
8.7.5	Final activities	39			
8.8	Cleaning the instant system	39			
8.9	Rinsing the mixer unit	41			
8.10	Cleaning the bean container	41			
8.11	Cleaning the instant container	42			
8.12	Cleaning the touch screen	42			
8.13	External cleaning	43			
9	Maintenance	43			
9.1	Intervals	43			
9.2	Faults	44			
10	Recycling and disposal	44			
10.1	Waste disposal	44			
10.2	Waste water disposal	44			
10.3	Disposal of cleaning agents	44			
10.4	Disposal of the machine	44			

General	1
Safety	2
Technical data	3
Installation	4
Operation	5
Dispensing products	6
Settings	7
Cleaning	8
Maintenance	9
Recycling and disposal	10

Translation of the original operating instructions



1 General

1.1 Manufacturer information

Melitta Professional Coffee Solutions GmbH & Co. KG
Zechenstr. 60
32429 Minden
Germany
Internet: www.melitta-professional.de

1.2 About these instructions

These instructions form part of the equipment. They contain important information on safety, installation, usage, and cleaning. Observing these instructions helps preserve your safety and helps avoid damage to the product.

We reserve the right to make changes to these instructions due to technical modifications. Reprints, translations, and reproductions in any form, including excerpts, require written agreement from the publisher.

The copyright is held by the manufacturer.

1.3 Explanation of symbols

▲ DANGER

Danger of death!

Identifies hazards that could result in serious injury or even death if the corresponding hazard notice is not observed.

▲ WARNING

Personal injury!

Identifies hazards that could result in injury if the corresponding warning notice is not observed.

▲ CAUTION

Minor injuries!

Identifies hazards that could result in minor injuries.

ATTENTION

Property damage!

Identifies the risk of possible property damage.



Note

Identifies usage tips and useful information.

1.4 Description

This machine is a fully automatic coffee machine. Depending on the machine equipment level, the following products can be dispensed:

- Coffee, coffee and milk, and milk products
- Instant products
- Hot water and steam

The housing consists of stainless steel and high-quality plastic. The design of this machine facilitates compliance with the following operator requirements:

- HACCP hygiene guidelines
- Accident prevention regulations for electrical safety in the commercial sector

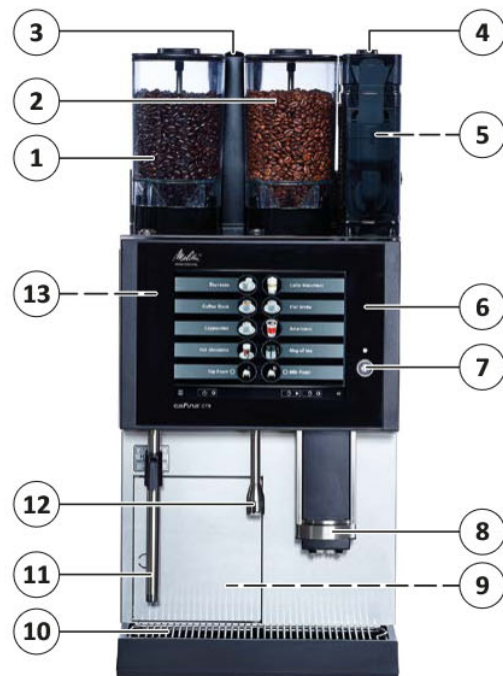

Fig. 1: Overview

- 1 Bean container 1 (left)
- 2 Bean container 2 (right)
- 3 Chute
- 4 Instant container
- 5 Mixer unit (behind the instant system cover)
- 6 Machine door with display (touch screen)
- 7 Chip key contact surface
- 8 Beverage outlet (height-adjustable)
- 9 Coffee grounds drawer (behind the grounds drawer door)
- 10 Drip grid

000631

- 11 Steam wand, milk foam wand (options)
- 12 Hot water wand (option)
- 13 Main switch (behind the machine door)

The nameplate is located on the inside of the grounds drawer door.

1.5 Accessories

Accessories supplied

- 2 green user chip keys
- 1 yellow manager chip key
- 1 cleaning container, white
- Machines with top foam: 1 cleaning container, blue
- 1 removal tool
- 1 microfiber cloth
- 1 tin of Melitta® Cafina® Multi TF-Tabs (art. no. 31547)
- 10 bags of Melitta® Cafina® AMC cleaner (art. no. 35289)
- 1 coffee measure 8 g
- 1 set of operating instructions

Accessories available

Cup warmer	CT CW
Milk coolers	CT MC, CT MCS, CT MCU
Billing systems	Coin acceptor, coin changer, card reader
Grounds disposal	Container discharge
Supply containers	Lockable containers

1.6 Conformity

The manufacturer hereby declares that the product described in these operating instructions complies with the EU Directive on “electromagnetic compatibility”, the “Directive on the restriction of the use of certain hazardous substances in electrical and electronic equipment”, and, where applicable, the “Machinery Directive” or the “Low Voltage Directive”. Applicable as well as further details can be found in the EU declaration of conformity provided separately.

1.7 User interface

These instructions describe the user interface in a more modern variant, recognizable by the menu symbol “≡” (1) at the bottom left (see Fig. 6). If you see a menu bar instead, similar to the menu bar of the manager menu (see Fig. 30), you can find the corresponding operating instructions (“GUI 1”) on the following website: www.planerhandbuch.de

2 Safety

2.1 Intended use

This machine is a fully automatic coffee machine for dispensing coffee, coffee and milk, and milk products as well as hot water at increased daily requirements of beverages in the gastronomic sector.

The following operating modes are available:

- Operation by trained personnel
- Supervised self-service operation
- Operation with fixed water connection
- Non-pressurized operation via fresh water and waste water canisters
- Stationary installation within dry, enclosed rooms

This machine is **not** intended for the following uses:

- In areas with high air humidity (e.g., areas with considerable amounts of steam) or outdoors.
- On board vehicles or mobile facilities (please contact the manufacturer).

2.2 Safety information

2.2.1 General

The following safety information relates to the machine only. In addition, there may be legal requirements in place for the owner/operator, e.g., regarding food hygiene and safety at work.

- Only use the machine when you have read and understood these instructions in full.
- When operating the machine, always observe all information and guidelines in these instructions.
- Keep these instructions at the place of use of the machine.

2.2.2 Personnel

- This machine can be used by children of 8 years and above as well as persons with reduced physical, sensory, or mental capabilities if supervised or when they have been trained in the safe use of the equipment.
- Children under 8 years of age must be kept away from the machine.
- Children must not be permitted to play with the equipment.
- Cleaning and user maintenance must not be performed by children.
- Persons with limited experience and knowledge must be able to recognize hazards arising from incorrect operation.
- A user is only permitted to operate the machine without supervision if it has been explained in such a way so that the user knows how to operate it safely.
- In self-service operation, the machine must be supervised by trained personnel.
- Repairs and maintenance work may only be carried out by Melitta customer service or by specialist personnel authorized by the manufacturer. Incorrectly performed repair work can result in considerable risk to the user.

- The area reserved specifically for customer service is only to be accessed by persons who have sufficient knowledge and practical experience of the equipment, particularly with regard to safety and hygiene.
- Settings may only be made, and cleaning and preparation work may only be carried out on the machine by persons who have been trained by the installation engineer or by the manufacturer.
- Faulty components may only be replaced with original spare parts. Otherwise warranty claims will be void.

2.2.3 Correct use

- The machine can be damaged by penetrating water. The machine is not protected against jets of water. Protect the machine against water and spray water.
 - Never pour water over the machine.
 - Do not use any water jets, high-pressure cleaners, or steam cleaners to clean the machine.
 - The machine is not suitable for installation on a surface where a water jet might be used.
- When the machine is unattended for extended periods, switch it off at the main switch and close the water tap.
- Never open the covers unless explicitly instructed to do so. Similarly, never remove bolts and the housing parts that they hold in place. Contact with live parts poses a danger of death due to electrical voltage.
- Never reach into a machine opening when the machine is running.

- Do not hold any body parts under the outlets when hot liquids or steam are being dispensed. This occurs in the following situations:
 - After switching on
 - When beverages are being dispensed
 - During automatic cleaning
 - During rinsing processes (e.g., when switching off)
- Do not touch any hot parts.
- When products are being dispensed, there is a risk of scalding from the actual products. Always take care when handling hot beverages.
- Take note of any visible damage or malfunctions. Obvious malfunctions include water leaks, odors and heat formation, unusual noises, as well as error messages on the display. In the event of any unusual situation:
 - Disconnect the mains plug
 - Switch off the water supply
 - Contact customer service
 - Have the machine checked and repaired by customer service
- Clean the machine at least once per day, especially the parts in contact with milk. Impurities could cause health problems.
- Comply with all intervals for cleaning, inspection, and maintenance, as specified in the instructions. Otherwise, the safety, functional reliability, and durability may be impaired.

3 Technical data

Machine specifications

Dimensions (W x D x H)	350 x 650 x 810 mm	2
Weight	approx. 70 kg	
Coffee supply	2 x 3 l / 2 x approx. 1000 g	3
Instant supply	1 x 1.3 l / 1 x approx. 1000 g	
Coffee grounds drawer capacity	For approx. 40 portions	

Operating data

Hourly output	40 l hot water or 142 cups of Café Crème (125 ml) (2 x Café Crème 198 cups)
Permissible ambient temperature	+ 5-30 °C
Permissible air humidity	< 80 % non-condensing
Noise level	< 70 dB(A)

Electrical connection

Power supply	400 V-3N, 50-60 Hz
Power consumption	Maximum 7 kW
Fuse protection provided by customer	3 x 16 A (required)
Connection	1.8 m mains cable with mains plug (e.g., CEE 16 A)

Water connection

Fresh water connection	G 3/4" outer thread
Fresh water pressure	At least 0.25 MPa (2.5 bar) at approx. 2 l/min, a pressure reducer is required for static pressures higher than 0.6 MPa (6 bar)
Fresh water carbonate hardness	1-3 °dKH: no action required, 4 °dKH and above: decarbonization system required (e.g., BRITA-Purity), less than 1 °dKH: consult manufacturer
Waste water connection	At least DN 25 - NW 1"

4 Installation

The machine is set up, installed, and handed over ready for use by customer service. Due to the associated hazards, modifications to the installation or setup must be carried out by customer service only.

4.1 Prerequisites

Make sure that the following prerequisites are met before you use the machine.

4.1.1 Water connection

The water connection must be easy to shut off at any time during operation (shut-off valve). The equipment is to be installed to comply with the applicable federal, state, or local plumbing codes and regulations, e.g., EN 61770.

The limit values for water pressure and carbonate hardness as given in the technical data must be observed.

Only use a new hose set. Old or used hose sets are not permitted to be reconnected.

The water drain must only be installed via a fixed connection with odor trap that is protected against backwater and backflow. This prevents contamination in the machine due to backflowing waste water.

4.1.2 Electrical connection

The supply voltage must match the specifications on the nameplate.

The supply line must be fuse-protected at the site with 3 x 16 A. The connection must also be protected using a residual current circuit breaker (RCCB) (max. 30 mA).

If the equipment is connected permanently, a switch for an all-pole disconnection with at least three millimeters of contact clearance must be provided by the customer.

For connection via a mains plug, the socket must be easily accessible during operation so that the plug can be disconnected in the event of a fault.

Due to the high power, a separately fused circuit is required for the machine.

This machine must be connected to a supply with a mains impedance Z_{\max} of no more than 0.4422 Ohm. If required, please consult your supply authority for mains impedance information.

4.1.3 Installation location

The machine is only to be installed and used in enclosed, dry areas; it must not be operated outdoors.

The effects of humidity and temperature may adversely affect the function and safety of the equipment.

The machine must always be installed and stored in frost-free locations.

The installation area must provide sufficient distances from walls and objects due to the heat generated and for operation of the machine.

Distances

To the back	At least 5 cm
To the top	At least 20 cm

In self-service operation, the machine and all accessory units must be installed in such a way that they can be permanently supervised by trained personnel.

The machine must be positioned level and free of vibrations. Adjustable feet are provided so that the unit can be leveled out on slightly uneven surfaces.

4.1.4 Product material

Coffee beans must be suitable for use in commercial coffee machines.

Extraneous matter, such as pieces of wood, stones, or metal, etc., must be removed to prevent damage to the grinder.

Ground coffee or instant powder must be suitable for use in commercial coffee machines. Only use dry and loose material without clumps.

To ensure milk foam of the best possible quality, use ultra-heat treated (UHT) milk cooled to a temperature of 3 °C (± 2 °C).

Do not use milk that has not been treated in a dairy. Lactose-free milk, milk from animals other than cows, soy milk, alternative sources of protein, or additives can be used; then, however, the cleaning of the milk system cannot be ensured. The machine's owner/operator is responsible for any breakdowns and work by customer service.

4.2 Canister operation (option)

If your machine cannot be permanently connected to the fresh water and waste water system, you can also operate it with two canisters.

Also observe the limit values for the water carbonate hardness in this process. Where necessary, the fresh water supply must be topped up via a water filter (e.g., BRITA-Purity).

The canisters must always be installed by customer service.



Note

Particular care with regard to hygiene is required for canister operation. Observe the relevant notes in chapter 8.5 on page 35.

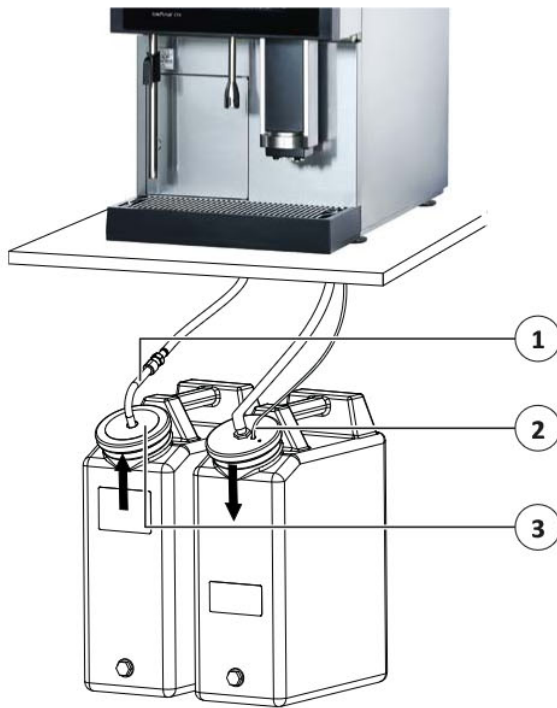

Fig. 2: Canister operation

In daily operation, the fresh water canister must be filled with sufficient water and the waste water canister must be drained when necessary.

4.2.1 Filling the fresh water canister

1. Pull the suction lance (1) together with the cover disk (3) out of the canister lid.
 2. Unscrew the lid from the canister.
 3. Before filling, clean the fresh water canister and its lid area with standard dishwashing detergent and rinse off the cleaner residues thoroughly.
 4. Fill the canister with fresh water.
 - Observe the limit values for the water carbonate hardness. Where necessary, the fresh water supply must be topped up via a water filter (e.g., BRITA-Purity).
 5. Screw the lid back onto the canister.
 6. Slide the suction lance (1) through the hole in the canister lid.
 - Make sure that the suction lance touches the bottom of the canister.
 7. Place the cover disk (3) on the lid.
- ✓ The fresh water canister is ready for operation.

4.2.2 Emptying the waste water canister

1. Remove the drain tube (2) from the canister lid.
 2. Unscrew the lid from the canister.
 3. Empty the canister.
 4. Screw the lid back onto the canister.
 5. Insert the drain tube (2) through the hole in the canister lid.
- ✓ The waste water canister is ready for operation.

5 Operation

Initial commissioning is carried out by customer service. If you want to put the machine back into operation following a standstill, clean the machine as described (see chapter 8 on page 33).

5.1 Chip keys

Included with the machine are two green user chip keys and one yellow manager chip key.

5.1.1 Green user chip key

The green user chip keys can be used to carry out the following actions:

- Switching on/off the machine.
- Changing the filling levels.
- Carrying out a full cleaning of the machine.
- Cleaning the touch screen.
- Rinsing the mixer unit.
- Viewing and editing the weekly planner.

5.1.2 Yellow manager chip key

The yellow manager chip key provides the same options as the user chip key. The following additional actions can be carried out:

- Making settings on the machine.
- Editing the dispensing products.
- Creating/editing product groups.
- Displaying consumption and product statistics.

5.1.3 Without chip key

Waiter operation

Without a chip key, the following options are available in waiter operation:

- Dispensing preset products.
- Emitting steam.
- Switching on/off the machine.
- Changing the filling levels.
- Carrying out a full cleaning of the machine.
- Cleaning the touch screen.
- Rinsing the mixer unit.
- Viewing and editing the weekly planner.

Self-service operation

Without a chip key, you can only dispense preset products in self-service operation.

5.1.4 Logging in with a chip key



Fig. 3: Logging in with a chip key

1. Hold one of the chip keys on the contact surface (1) at the front of the machine so that the inner and outer contact surfaces are fully connected to one another by the chip key.
- ✓ You are logged in and can use the corresponding functions.

5.2 LED status indication

An LED (2) (see Fig. 3) above the chip key contact surface shows the current status of the machine:

LED	State
Off	Machine is switched off and can be switched on with the main switch (see chapter 5.3.1 on page 11).
White flashing	Machine switches on.
White permanently	Machine is ready for dispensing.
Red	Machine is in stand-by operation. To switch on see chapter 5.3.2 on page 11.
Blue flashing or permanently	Malfunction: Switch off the machine with the main switch and switch it on again. If this occurs repeatedly, contact customer service.

5.3 Switching the machine on and off

5.3.1 Switching on



Fig. 4: Switching on the machine

1. Check that the water supply is on.
2. Open the machine door using the key (1).
3. Switch the machine on using the main switch (2).
4. Close the machine door.
5. Continue as described in chapter 5.3.2 on page 11.

► Note

The main switch can be used to switch the machine off entirely, e.g., during extended standstills.

5.3.2 Stand-by operation

In daily operation, it is sufficient to switch the machine on and off via the display only (stand-by operation):

1. Depending on the operating mode, proceed as follows:
 - **Self-service operation:** Hold one of the chip keys on the contact area at the front of the machine (see chapter 5.1.4 on page 10).
 - **Waiter operation:** Touch the display.

The question “Switch on unit?” is shown on the display.

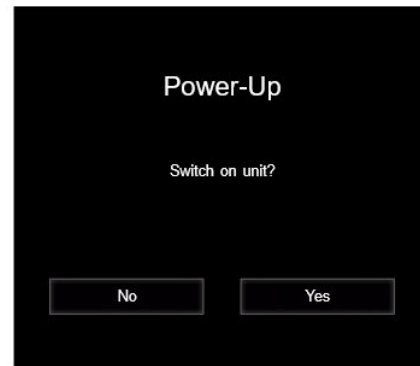

Fig. 5: Switching on the machine

2. Confirm this using “Yes”.

The switch-on process is started and takes several minutes.

▲ CAUTION

Danger of burns on the beverage outlet!

Hot water runs out of the beverage outlet when the lines are rinsed.

- Do not reach underneath the outlets.
 - The lines are rinsed.
 - The machine is heated to the required temperature.
 - The required pressure is built up in the steam boiler.

The switch-on process is displayed by a flashing white LED above the chip key contact surface. The LED lights up in white permanently when the machine is ready for dispensing.

- ✓ The machine is ready for operation.

► Note

After switching on the machine, the filling levels of the supply containers must be checked. If necessary, the supply containers must be filled and the filling levels confirmed.

5.3.3 Switching off



Note

For hygiene reasons, the machine must be switched off only in a cleaned state.

Always use the “Clean and switch off full system” function. The “Switch off” function (in the manager menu) is permitted to be used only if a cleaning process of the full system has been carried out and no further products have been dispensed.

For an extended standstill

If the machine will not be used for an extended period, turn off the water supply and switch off the main switch.



Note

For hygiene reasons, the machine must be switched off only in a cleaned state.

If you want to take the machine out of operation, contact customer service.

When switching off, the machine goes into stand-by mode.

5

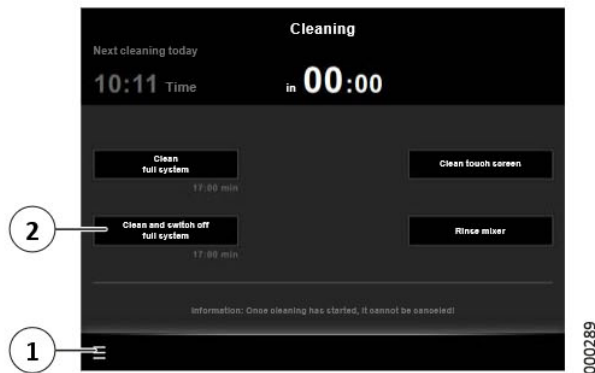

Fig. 6: Switching off the machine

1. On the display, press the menu symbol “≡” (1) and then “Cleaning”.
 - In self-service operation, you must first log in with a user chip key (see chapter 5.1.4 on page 10).
 2. Press the “Clean and switch off full system” button (2).
 - The next steps are described in chapter 8.7 on page 35.
- ✓ The cleaning program is carried out. The machine is then switched off.

5.4 Filling

► Note

The filling level must be confirmed at the machine each time a supply container is filled (see chapter 5.5 on page 15).

5.4.1 Filling the coffee supply

There will be one or two bean containers depending on the equipment.



Fig. 7: Filling the bean container

1. Remove the lid on the bean container.
 2. Fill the correct beans into the corresponding bean container, e.g., espresso beans in container 1 (1) and coffee beans in container 2 (2).
 3. Refit the lid.
- ✓ The bean container has been filled.

To simplify filling, the relevant container can be removed.



Fig. 8: Removing the bean container

1. Remove the lid on the bean container.
2. Turn the lever (1) a ¼ turn counterclockwise.
3. Remove the bean container (2).
4. Fill the coffee beans into the bean container.
5. Refit the bean container back into the machine.
6. Turn the lever a ¼ turn clockwise back to the original position.
7. Refit the lid.

✓ The bean container has been filled.

► Note

The coffee grounds drawer should also be emptied every time the coffee supply is filled (see chapter 5.6 on page 16).

5.4.2 Filling the instant powder (option)



Note

If you have a lockable instant container, use the key to open and close the lid.



000076

Fig. 9: Filling the instant powder

5.4.3 Filling the milk (option)

There will be one or two milk containers and milk tubes depending on the equipment.

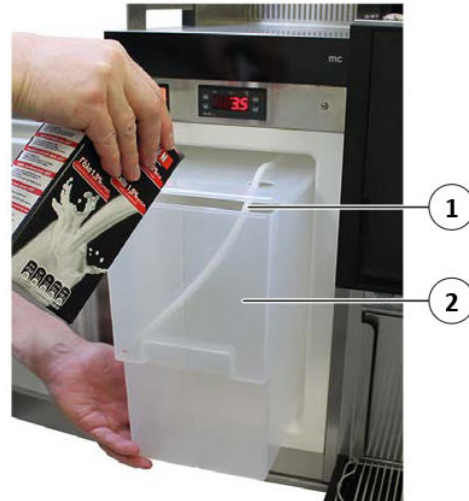

000571

Fig. 10: Filling the milk container

1. Remove the lid on the instant container.
 2. Fill the right instant powder into the container, e.g., cocoa.
 - The instant container has a protective cover that is not permitted to be removed.
 - Ensure that the powder is not compressed.
 3. Refit the lid.
- ✓ The instant container has been filled.

1. Open the door of the refrigerator.
 2. Fill the milk container (2) with pre-cooled milk or prepare a container filled with pre-cooled milk.
 3. Place the milk tube (1) into the container.
 4. Close the door of the refrigerator.
- ✓ The milk supply has been filled.

5.5 Confirming filling levels

The filling level must be confirmed at the machine each time a supply container is filled.

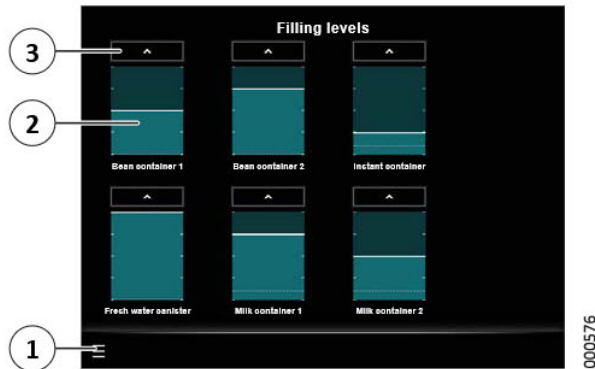

Fig. 11: Confirming filling levels

- On the display, press the menu symbol “≡” (1) and then “Filling levels”.
 - In self-service operation, you must first log in with a user chip key (see chapter 5.1.4 on page 10).
 - Press the required “^” button (3) above the filling level displays to mark the following containers as full (from left to right and top to bottom):
 - Bean container 1 (left)
 - Bean container 2 (right)
 - Instant container
 - Fresh water canister
 - Milk container 1
 - Milk container 2
- ✓ The filling levels have been confirmed.

To return to the start screen, proceed as follows:

- Self-service operation:** On the display, press the menu symbol “≡” (1) and then “Logout”.
- Waiter operation:** On the display, press the menu symbol “≡” (1) and then “Selection”.

You can adjust the filling levels even more accurately.

- Press the required filling level display, e.g., of the bean container 1 (2).
 - A new window opens.

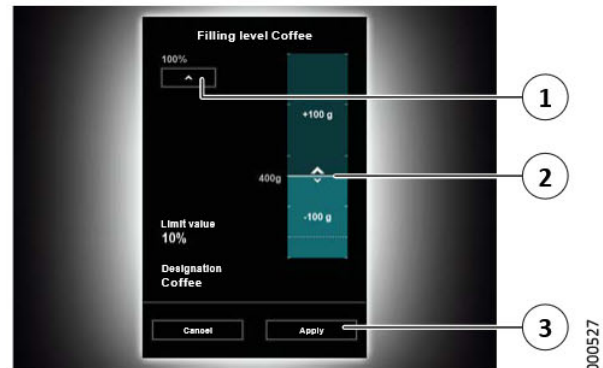

Fig. 12: Adjusting filling levels more accurately

- Select one of the following options:
 - Press the “^” button (1) to mark the container as full.
 - Touch the filling level display above or below the bar (2) to adjust the filling level in steps.
 - Slide the bar (2).
 - Press the “Apply” button (3) to adopt the settings and return to the previous screen.
- ✓ The filling levels have been confirmed.

If the filling level for a consumable drops below a set value, a warning will appear on the display. If you confirm that the consumable has been refilled, you can then adjust the new filling level straight away in a similar dialog as shown in Fig. 12.

5.6 Emptying the coffee grounds drawer

The coffee grounds drawer must be emptied if the coffee grounds are not disposed of via the optional container discharge.

When the coffee grounds drawer is full or almost full, the message is displayed that the grounds drawer must be emptied:

- If the coffee grounds drawer is 75 % full, only a few more brewing processes can be carried out.
- If the coffee grounds drawer is 100 % full, only products that do not release coffee grounds can be dispensed. All other products are grayed out and cannot be selected.



Fig. 13: Emptying the coffee grounds drawer

1. Swivel the wand (2) (if present) forwards.
2. Swivel the hot water wand (3) (if present) to the right.
3. Open the coffee grounds drawer door (1) by touching.
4. Pull out the coffee grounds drawer.
5. Empty the coffee grounds into the household waste.
6. Reinsert the coffee grounds drawer.
7. Close the coffee grounds drawer door (1).

After reinserting the emptied coffee grounds drawer, a prompt to confirm whether or not the grounds drawer has been emptied appears on the display.

8. Confirm the prompt by pressing the “Yes” button.
- ✓ The coffee grounds drawer has been emptied.

5.7 Viewing the weekly planner

If this function is enabled by customer service, you can view and edit the timetable for the fully automatic operation of the machine with the weekly planner.

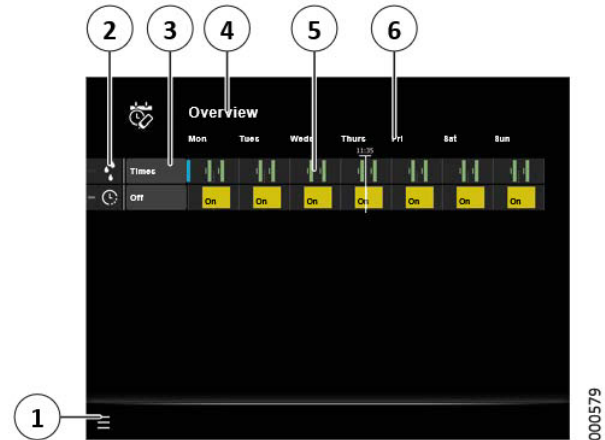

Fig. 14: Weekly planner

1. On the display, press the menu symbol “≡” (1) and then “Weekly planner”.
 - In self-service operation, you must first log in with a user chip key (see chapter 5.1.4 on page 10).

The fully automatic operation can be configured per weekday. Each row is one operating parameter which can be set over the course of one week:



Cleaning times



Switching on/off



Note

If enabled by customer service, you can edit the weekly planner here as described in chapter 7.6.3 on page 30.

The symbols (2) indicate whether the fully automatic operation by the weekly planner is activated or deactivated for the corresponding parameter.

The field next to the symbols determines the base setting of the parameter, for example, for “switching on/off”, if the base setting of the machine is principally “on” and switch-off times are specified, or “off” and switch-on times are specified.

2. Press a row (5) to view the events set for the parameter in question.
 - The check mark at the bottom right closes the display of the events for the corresponding parameter.
 3. Press a weekday (6) to display the selected weekday in 24 hours.
 - When pressing a time of day, you can zoom in on the timeline further and out again.
 - With the buttons “<” and “>” you can scroll the timeline.
 - Press the title (4) to return to the previous display.
- ✓ The weekly planner has been viewed.

5.8 Locking product dispensing

You can lock product dispensing temporarily.

1. Hold the manager chip key on the contact area at the front of the machine (see chapter 5.1.4 on page 10).
 2. On the display, press the “Unit” button.
 3. On the display, press the “Lock product selection” button.
- ✓ Product dispensing has been locked.

To activate product dispensing again, hold one of the chip keys on the contact surface at the front of the machine (see chapter 5.1.4 on page 10).

5.9 System messages

5.9.1 Messages in self-service operation

In self-service operation, system messages are indicated by a notice symbol.

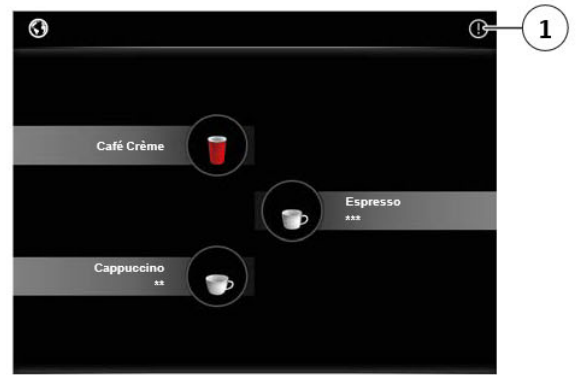

Fig. 15: System messages

You can view the system messages by pressing the symbol (1).

5.9.2 Messages in waiter operation

In waiter operation, system messages are displayed, for example, if a product material has run out (e.g., “Bean container empty”), directly on the display.

A notice symbol to the right of the lower bar will then refer you to any system messages that have not been rectified. You can view the system messages by pressing the symbol.

6 Dispensing products



Note

Before dispensing products, all supply containers must be inserted and filled as otherwise no more products can be dispensed.

Once the machine has heated up, the products that can be dispensed are listed on the display. Products that are not available, e.g., due to a shortage, are grayed out.

⚠ CAUTION

Danger of burns due to hot products!

Contact with the product dispensed can result in burns.

- Do not reach underneath the outlets during operation.

6.1 Product dispensing

To dispense a product, press the corresponding product button on the display.



Fig. 16: Product dispensing in waiter operation

Groups and dispensing settings are labeled using the following symbols:

- Pressing a product button without a symbol dispenses the listed product (1) once.
- Pressing and holding a product button with the “o” symbol dispenses the product (3) until contact is ceased.
- The symbol “≡” identifies a product group (2).

You can select dispensing products sorted into groups by opening the specified group via touch and accessing the required product for dispensing. After a product from a group has been dispensed, use the “←” symbol (4) (top left in self-service operation) to return to the start screen, or wait for a short while until the start screen appears automatically.

Display language

The display language which is displayed by default and the languages available for self-service operation are determined via the machine settings in the manager menu (see chapter 7.7.3 on page 32).

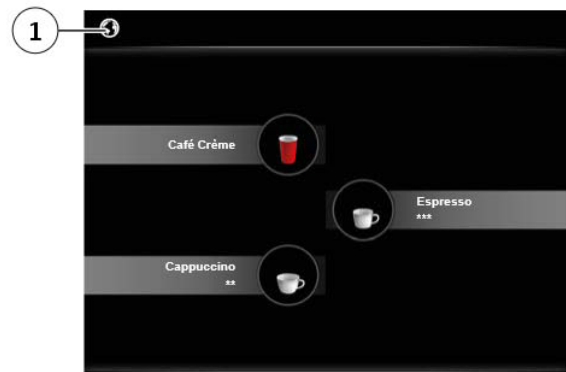

Fig. 17: Product dispensing in self-service operation

In self-service operation, the user can change the display language temporarily via the language selection symbol (1).

6.2 Canceling the product dispensing

Depending on the product preset, you can cancel the ongoing product output by pressing “X” during dispensing (see, for example, Fig. 25).

6.3 Dispensing coffee, coffee and milk, and milk products



Fig. 18: Dispensing products

1. Pull the beverage outlet (2) upwards so that the required cup fits underneath.
2. Position the cups, pots, or glasses underneath the beverage outlet on the drip grid (1).
3. Move the beverage outlet downwards until just over the cup edge.
4. Press the corresponding product button on the display.

✓ The product is dispensed.

6.4 Dispensing hot water (option)



Note

If there is no hot water wand fitted, hot water is dispensed via the beverage outlet.



Fig. 19: Dispensing hot water

1. Position the cup underneath the hot water wand (2) on the drip grid (1).
2. On the display, press the button for dispensing hot water.

✓ The product is dispensed.

6.5 Dispensing steam (option)

Depending on the equipment provided, the steam wand may be one of the following:

- Basic steam wand
- Steam wand with Steam Control Plus

⚠ CAUTION

Danger of burns due to hot steam wand!

Contact with the steam wand and steam can result in burns.

- During operation, touch the steam wand on the handle only.
- Do not touch the steam wand with bare hands when cleaning.



Note

A maximum of 0.5 liters of milk can be frothed.

The frothed milk will be hot. For preparation, use a cup with a handle and only touch the cup using the handle.

6

6.5.1 Basic steam wand



Fig. 20: Dispensing steam

1. Hold the cup for frothing milk underneath the steam wand (1).
 - Touch the steam wand on the handle (2) only.
 2. On the display, press the button for dispensing steam.
 3. Remove the cup from underneath the steam wand after frothing.
 4. Position the steam wand over the drip grid.
 5. Then press the button for steam dispensing again to blow out the steam line.
 6. Clean the outside of the steam wand immediately with a clean and damp cloth to remove milk residues.
- ✓ The steam dispensing operation is complete.

6.5.2 Steam wand with Steam Control Plus



Fig. 21: Dispensing Steam Control Plus

1. Place the cup containing milk (2) underneath the steam wand (3) on the drip grid (1) so that the steam nozzle is fully submerged in the milk.
 - Touch the steam wand on the handle (4) only.
2. Press the button on the display for dispensing Steam Control Plus.
 - The preparation process starts and the current temperature of the milk is shown on the display.
3. Remove the cup from underneath the steam wand as soon as the preparation process is complete.

The request “Blow out steam wand” is shown on the display.



Fig. 22: Blow out steam wand

4. Position the steam wand over the drip grid.
 5. Confirm the request with “Start” to blow out the steam line.
 6. Clean the outside of the steam wand immediately with a clean and damp cloth to remove milk residues.
- ✓ The Steam Control Plus dispensing process is complete.

If you wish to use Steam Control Plus again for product dispensing straight away, you can interrupt the steam wand blow-out process by pressing “Close”.

6.6 Dispensing milk foam via wand (option)

Depending on the equipment, a milk foam wand may be available instead of a steam wand. With the milk foam wand, you can add milk foam to your products separately.

1. Position the cup for the milk foam underneath the milk foam wand on the drip grid.
 2. On the display, press the button for dispensing milk foam.
- ✓ The product is dispensed.

6.7 Dispensing a double product

If this function is enabled by customer service, you can request two portions of a coffee/milk product and fill two cups simultaneously.



Fig. 23: Dispensing a double product

1. Position a cup (1) in the center underneath each dispensing nozzle (2).
2. Press the corresponding product button on the display.

The following prompt appears on the display:

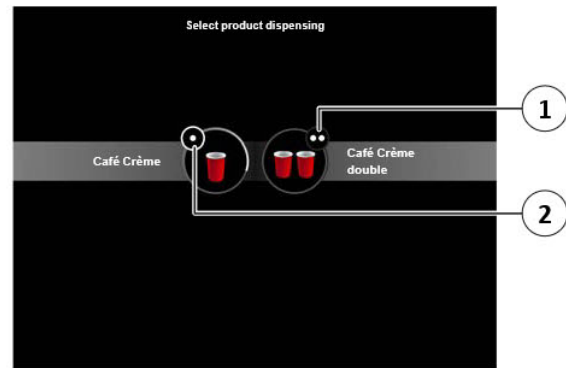

Fig. 24: Dispensing a double product

3. Select one of the following options:
 - Press the product with the symbol “☺” (1) to dispense two portions of the requested product.
 - Press the product with the symbol “☹” (2) to dispense a single portion of the requested product.

► **Note**
If neither of the product buttons is pressed, then a single portion of the product is dispensed automatically after a short time.

- ✓ The product is dispensed.

6.8 Dispensing quick start products

Depending on the preset in the manager menu (see chapter 7.1 on page 25), you can use the quick start buttons to dispense preset products (e.g., hot water, steam) either in parallel with normal product dispensing or directly after the currently running product component.

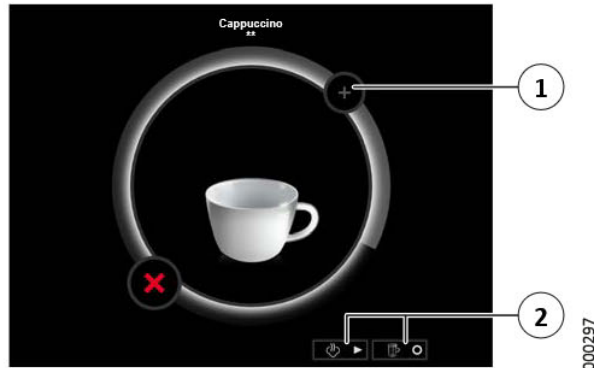

Fig. 25: Product dispensing with quick start buttons

1. During product dispensing press the symbol for the product (2) that you wish to additionally dispense in parallel or directly following the product component currently being dispensed.

6

- ✓ The product is dispensed.

6.9 Dispensing multiplier products

Under product settings (see chapter 7.5 on page 28), you can set up products as multiplier products. With this you can issue multiple portions of a product in succession if required, for example, to fill a larger cup.



Note

In order to dispense a multiplier product, there must be enough product material and capacity in the coffee grounds drawer.

1. Position a cup underneath the beverage outlet.
2. Press the corresponding product button on the display.
 - While the product is being dispensed, the display shows how many single products are included in the multiplier product and which single product is currently being dispensed (e.g., “1 / 4”, the first product of four single products).
 - The products are prepared and dispensed in succession.

- ✓ The dispensing of the multiplier product is complete.

6.10 Multiple dispensing of a single product

Multiple portions of a product can be requested as necessary and dispensed directly in sequence. The advantage of multiple dispensing is that you do not need to select the product again for every subsequent portion.

1. Position a cup underneath the beverage outlet.
2. Press the corresponding product button on the display.
3. While the product is being dispensed, press “+” (1) (see Fig. 25) multiple times in succession depending on the number of additional portions that you would like to dispense.
 - The products are prepared and dispensed in succession.
4. Once a portion has been dispensed, put the cup aside and place another cup underneath the beverage outlet.

- ✓ The multiple dispensing operation is complete.

6.11 Batch mode

If this function is enabled by customer service, you can preselect several products with the batch mode and dispense them in sequence.



Fig. 26: Batch mode

Depending on the preset in the manager menu (see chapter 7.1 on page 25), the batch mode (1) can be open or closed by default.

To open or close the batch mode manually, press the symbol “◀” (open) or “▶” (close) (3) to the right of the lower bar.

Product dispensing in batch mode

1. With the batch mode open, press the products to be dispensed in sequence.
2. Press the “▶” button (2) (see Fig. 26) on the display to start dispensing the first product.



Fig. 27: Dispensed product in batch mode

3. Once a product has been dispensed from the batch, remove it and position a suitable container for the next product underneath the corresponding beverage outlet.
4. Press the “▶” button (1) to continue dispensing the products.
 - Once all products from the batch have been dispensed, the machine returns to the start screen.

You can bring forward the dispensing of a product or multiple selection of a product from the batch so that it is the next in the sequence:

1. Press the required product or the multiple selection of a product in the batch.
2. Press the “▶” button (1) to continue dispensing the products with the selection.
 - Once all products from the batch have been dispensed, the machine returns to the start screen.

- ✓ The products have been dispensed and the batch mode is finished.

Adding or removing products in batch mode

Products which are already in the batch can be added or removed.

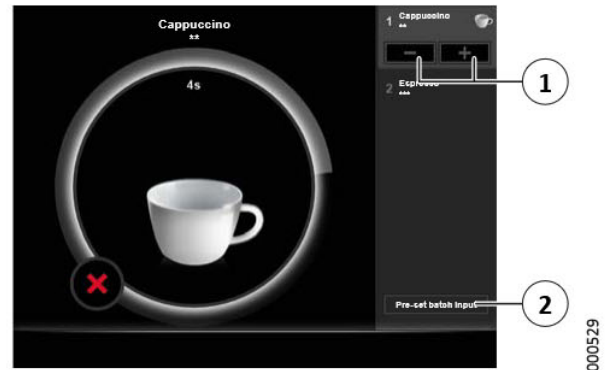

Fig. 28: Product dispensing in batch mode

1. Press the required product or the multiple selection of a product in the batch.
 2. Press the “+” (add) or “-” (remove) button (1) to add or remove the product once each time.
- ✓ The product is added to or removed from the batch.

Products which are not already in the batch can be added.

1. Select one of the following options:
 - Once a product has been dispensed from the batch, close and open the batch with the symbol in the bar (2) (see Fig. 27).
 - While the product is being dispensed, press the “Pre-set batch input” button (2).
 2. Press the products to be dispensed in succession.
- ✓ The products are added to the batch.

6.12 Preparing coffee from ground coffee

The manual coffee chute can be used to prepare coffee from ground coffee without taking beans from the bean container. This is normally used to prepare decaffeinated coffee. However, another type of ground coffee can normally also be added via the chute.



Fig. 29: Filling ground coffee

1. On the display, press the corresponding product button for the product with manual coffee addition.
 - The prompt for the manual coffee addition is shown on the display.
 2. Open the flap (1).
 3. Add a loosely filled measuring spoon (approx. 8-9 g) of ground coffee via the chute.
 - Do not fill too much ground coffee into the chute. Otherwise the machine cancels the operation with an error message. The ground coffee will be dispensed in the coffee grounds drawer.
 4. Close the flap (1).
 5. Confirm the filling process on the display.
- ✓ The coffee addition is confirmed and the product is dispensed.

7 Settings

The machine is preset to ensure that it is ready for immediate use for normal operation.

The functions described here are only accessible if enabled by customer service.

7.1 Opening the manager menu

The manager menu gives you access to advanced settings. You can find them in the bar at the bottom of the screen.

Button	Function
Selection	Activate products for dispensing, create/manage product groups (see chapter 7.4 on page 26)
Product	Edit dispensing products (see chapter 7.5 on page 28)
Unit	Clean/switch off the machine and change the filling levels (see chapter 7.6 on page 29)
Operation	Set up the machine, show dispensing statistics, and display important events (see chapter 7.7 on page 31)



No.	COMPONENTS	Production counter
009	Ground coffee quantity grinder 1	13,459
010	Ground coffee quantity grinder 2	3,887
011	Instant powder quantity 1	5,503
012	Instant powder quantity 2	3,470

Logout SELECTION PRODUCT UNIT OPERATION

Fig. 30: Manager menu

1. Hold the manager chip key on the contact area at the front of the machine.

✓ The display shows the manager menu.

7.2 Carrying out inputs

The machine allows you to enter designations and quantities via a screen keyboard.

When the screen keyboard appears on the display, you can use the following functions:



Fig. 31: Carrying out inputs

- Write using the letter/number field (2).
- Delete the entered characters (3).
- Save the input (4).
- Switch between upper and lower case (5).
- Cancel the input (1).

Some keys are also assigned with special characters (e.g., “S” key). Press the keys for a longer time to display the special characters.

7.3 Exiting the manager menu

1. Once you have carried out the required function, press the “Logout” button.

✓ The manager menu is closed.

7.4 Menu option “Selection”

Here you can select which pre-programmed products are displayed for dispensing.

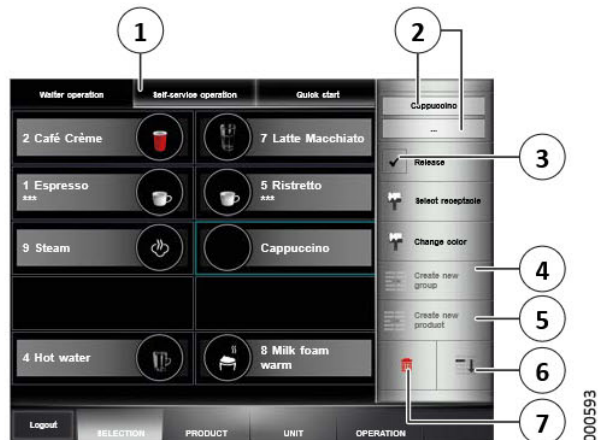

Fig. 32: Menu option “Selection”

For self-service and waiter operation, and for the quick start buttons, you can manage or create different dispensing products and product groups. You therefore always need to start by selecting the operating mode (1) for which you would like to create, delete, or edit products or product groups.

7.4.1 Product groups

In self-service and waiter operation, you have the option to group related products together. This means you can display and output more than ten assigned products.

7.4.2 Creating product groups

1. Tap a free dispensing position.
2. On the display, press the “Create new group” button (4).
 - A new group appears on the display.
3. To name the group, press the button for the first or second line of the name (2).
 - A new window opens.

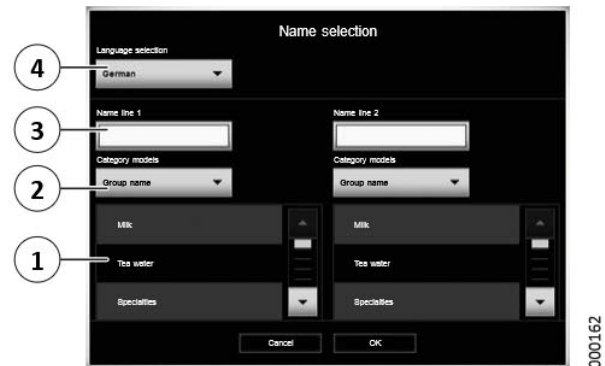

Fig. 33: Selecting or entering a name

4. Under “Language selection” (4), select the language that should be used for the name.
 - You can adjust the languages available for selection under the machine settings (see chapter 7.7.3 on page 32).
 5. Select one of the following options to enter a name for the line in question:
 - Select a default name: Under “Category models” (2), select a category and then select a name from the list below (1).
 - Enter your own name: Press the corresponding line (3) and enter a name using the screen keyboard (see chapter 7.2 on page 25).
 6. Confirm the name with the “OK” button.
 7. Press the “Release” button (3) (see Fig. 32) to activate the created group for dispensing.
 - If you do not release the group, it will not be displayed on the dispensing interface.
- ✓ The new product group has been created.

7.4.3 Adding dispensing products

Self-service and waiter operation

1. If you wish to add a dispensing product to a product group, open the required product group by pressing the product group twice.
 2. Tap a free dispensing position.
 3. Press the “Create new product” button (5) (see Fig. 32).
 4. Select the required dispensing product from the product list.
 5. Press the “Release” button (3) (see Fig. 32) to activate the created product for dispensing.
 - If you do not release the product, it will not be displayed on the dispensing interface.
 6. If you are in a product group, you can return to the start screen with the button “Overview” (2) (see Fig. 35).
- ✓ The dispensing product has been added.

Quick start buttons

1. Tap a free dispensing position.
 2. Open the dispensing position by tapping it again.
 3. Select the required dispensing product from the product list.
 - Products to be displayed in this list must be set up accordingly by customer service.
- ✓ The dispensing product has been added.

7.4.4 Sorting the dispensing view

1. Press the required product group or product button.
 2. Press the “Down” button (6) (see Fig. 32) to move the product group or product button downward.
 3. Sort the dispensing view.
 - Start with the last product group or product button at the bottom and end with the first product group or product button at the top.
- ✓ The dispensing view has been sorted.

7.4.5 Editing the dispensing view

1. Press the required product group or product button.
2. Select one of the following options to edit the display of a product group or dispensing product:

Button	Function
Release	Activate/deactivate for dispensing
Select receptacle	Assign an icon or image to a group
Change color	Change the color of the button or the text; you can specify your own colors in the machine settings (see chapter 7.7.3 on page 32)

- ✓ The dispensing view has been edited.

7.4.6 Delete displays

1. Press the required product group or product button.
2. Press the delete symbol (7) (see Fig. 32).
3. If prompted to confirm the deletion, press the “Delete” button to delete the product group or product button.



Note

Only the display on the screen is deleted. The products remain stored on the machine.

- ✓ The display for the product group or dispensing product has been deleted.

7.5 Menu option “Product”

Here you can change the values for product components, if enabled by customer service.

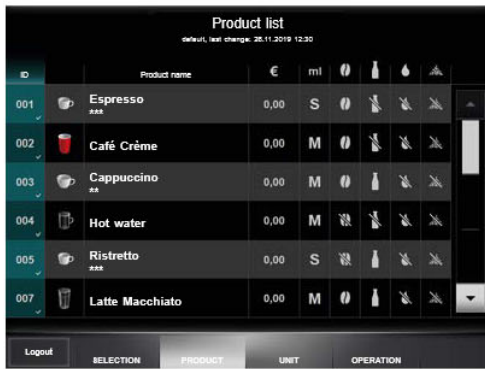

Fig. 34: Product list

7.5.1 Changing products

1. Select the “Product” menu to display a list of all products.
2. Use the “▲” and “▼” buttons to move the list to display all the programmed products.
3. Press on a product to edit it.
 - A new window opens.



Fig. 35: Product settings

4. Use the “▲” and “▼” buttons to scroll through the various settings options.
5. Select the component to be modified or value to be changed.
 - The naming is made in a similar dialog as in Fig. 33.

6. Change the values for the product using the screen keyboard.



Note

Products marked with an * in the ID cannot be edited. These products are pre-programmed in the basic settings for the machine.

7. Save your changes using the “Save” button.
 - Otherwise you will be prompted to confirm whether you want to discard the changes or whether you want to go back to save the changes.
- ✓ The values of the product components have been changed.

7.5.2 Duplicating a product

You can duplicate an existing product and then use it as a basis for a new product.

1. Select the required product from the product list.
2. Press the button (1) (see Fig. 35).
 - The prompt “Duplicate product” is shown on the display.
3. Confirm the prompt with “Duplicate”.

You can now change the various components in the duplicated product. Proceed as described in chapter 7.5.1 on page 28.

4. Save your changes using the “Save” button.
 - Otherwise you will be prompted to confirm whether you want to discard the changes or whether you want to go back to save the changes.
- ✓ The product has been duplicated.

7.6 Menu option “Unit”

Here you have the option of adjusting the filling levels, cleaning the machine, or switching it off, as well as programming a fully automatic operation.

7.6.1 Menu option “Filling levels”

Besides confirming the filling levels as described in chapter 5.5 on page 15, you can also make further settings on the filling levels in the manager menu.

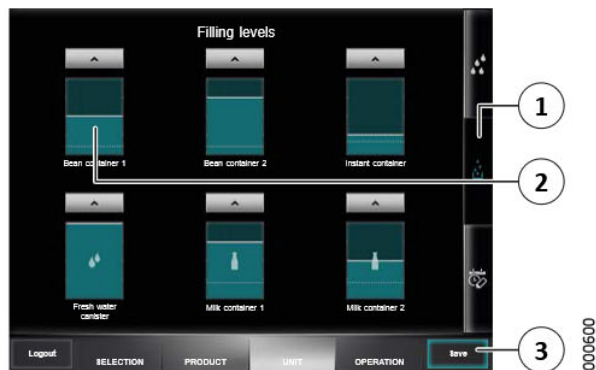

Fig. 36: Filling levels

1. Press the button “Filling levels” (1).
2. Press the required filling level display, e.g., of the bean container 1 (2).
 - A new window opens.



Fig. 37: Further filling settings

3. The “Designation” button (2) can be used to change the name of the container.

If the filling level for a consumable drops below a set value, a warning will appear on the display.

4. The “Limit value” button (1) is used to set a percentage at which a warning is issued for the filling level.
 - Enter the number “Zero” to switch this warning off.
5. Press the “Apply” button (3) to adopt the settings and return to the previous screen.
6. Save your changes using the “Save” button (3) (see Fig. 36).
 - Otherwise you will be prompted to confirm whether you want to discard the changes or whether you want to go back to save the changes.

✓ The filling level settings have been changed.

7.6.2 Menu option “Maintenance”

Here you have the option of cleaning the machine or switching it off.

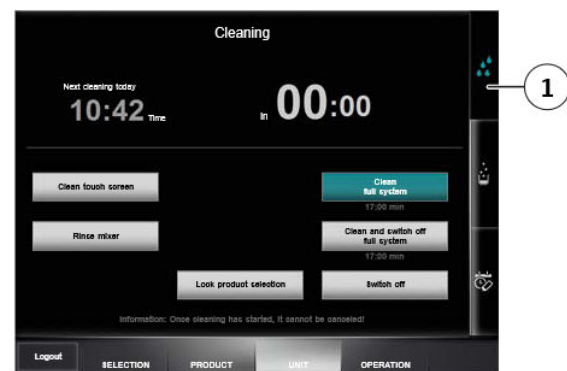

Fig. 38: Maintenance

1. Press the “Maintenance” button (1).

A time until the next cleaning and the time of the next prompt for cleaning are shown on the display. The cleaning that should be performed next is highlighted in color.

2. Carry out the required option:

► **Note**
For hygiene reasons, the machine must be switched off only in a cleaned state.

The “Switch off” function is permitted to be used only if a cleaning process of the full system has been carried out and no further products have been dispensed.

Option	Options
Clean touch screen	Clean the touch screen while the display is locked, see chapter 8.12 on page 42
Clean full system	Clean the milk and brewing system, then continue machine operation, see chapter 8.7 on page 35
Rinse mixer	If required, rinse the mixer unit, see chapter 8.9 on page 41
Clean and switch off full system	Clean the milk and brewing system, then switch off the machine, see chapter 5.3.3 on page 12
Lock product selection	Lock product dispensing temporarily, see chapter 5.8 on page 17
Switch off	Switch off the machine

7

✓ The selected option is carried out.

7.6.3 Menu option “Weekly planner”

Besides viewing the weekly planner as described in chapter 5.7 on page 16, you can configure the fully automatic operation if enabled by customer service.

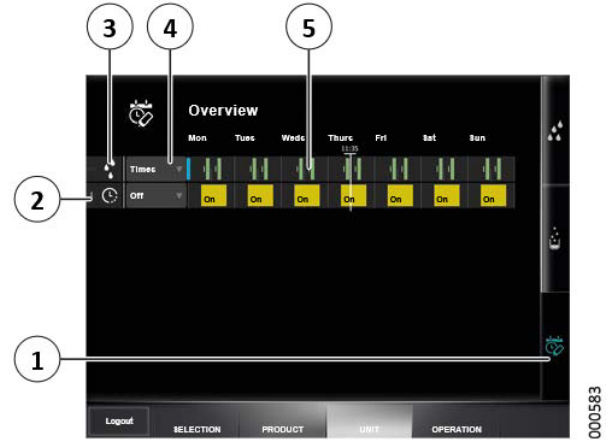

Fig. 39: Weekly planner

1. Press the “Weekly planner” button (1).
2. Activate or deactivate a parameter for the fully automatic operation by pressing the symbol (3).
 - In case the preceding line is horizontal, you cannot change the operating state of this parameter.
 - Cleaning times cannot be deactivated.
3. Determine the base setting of the parameter with the field next to the symbol (4).

Parameter	Base setting
Cleaning times	<p>Once per day a cleaning of the full system is required. For the automatic cleaning prompt on the display either set cleaning times (“Times”) or state the latest time of day (“1x / day”).</p> <p>Additionally, if enabled by customer service, set a weekend operation. With this you can temporarily suspend the daily cleaning prompt (machine components will be deactivated if necessary). The begin of a weekend operation must be confirmed. If required, a cleaning will be performed.</p>
Switching on/off	<p>Machine is principally “on” and switch-off times are specified, or machine is principally “off” and switch-on times are specified.</p>

- Press a row (5) to set up or edit events.

► **Note**
If you cannot confirm an event and if it is shown in red in the timeline, the event is in conflict with an already configured event.

- ✓ The weekly planner has been edited.

7.7 Menu option “Operation”

Here you can read off the consumption and product statistics and adjust settings for the machine.

7.7.1 Opening usage statistics



Fig. 40: Usage statistics

- Press the “Usage statistics” button (1) to open the usage statistics for ground coffee and instant powder.
 - Press the line containing the statistics symbol (2) to view statistics on the weight of sample and brew duration.
 - Select the corresponding grinder and product.
 - You can use the filter to display statistics according to various criteria.
- ✓ The usage statistics are opened.

7.7.2 Opening product statistics

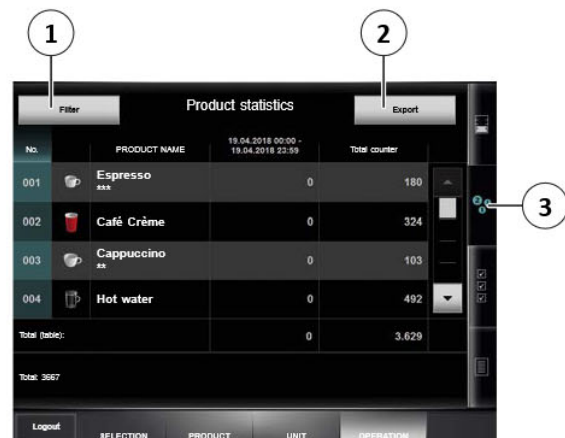

Fig. 41: Product statistics

- Press the “Product statistics” button (3) to see how many times a product has been dispensed.

2. Use the “▲” and “▼” buttons to move the list to display all the programmed products.
 3. Press the “Filter” button (1) to display products according to various criteria.
- ✓ The product statistics are opened.

You can export the product statistics list to a USB stick, e.g., for further processing. The exported data will be stored in CSV format in the USB stick’s root directory.

4. Open the machine door using the key.



Fig. 42: Inserting the USB stick

5. Slide the cover on the inside of the machine door (1) to the side.
 6. Insert a suitable USB stick (2) into the USB slot.
 - Not every USB stick is suitable for use. The machine door must be able to close when the USB stick is inserted.
 7. Close the machine door.
 8. Press the “Export” button (2) (see Fig. 41).
 9. Select one of the following options:
 - Press the “Filtered” button to only export the displayed, filtered section of the product statistics.
 - Press the “All” button to export the entire product statistics list.
 10. Open the machine door.
 11. Remove the USB stick and slide the cover back.
 12. Close the machine door.
- ✓ The product statistics list has been exported.

7.7.3 Machine settings

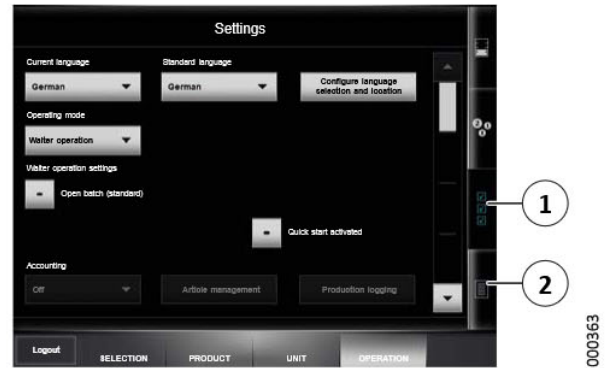

Fig. 43: Machine settings

1. Press the “Settings” button (1) to display and edit the basic settings for the machine.
2. Use the “▲” and “▼” buttons to move the list to show all the settings options:

Button	Settings
Current language	Set the display language.
Standard language	Language to be displayed by default in self-service operation. If a different language has been set, this language will be displayed again after five minutes without any input.
Configure language selection and location	Select the languages for “Current language” and “Standard language” and set the location (country).
Operating mode	Set the default mode for the machine: Self-service operation or waiter operation.
Waiter operation settings	For waiter operation, set whether the batch processing should be open by default or whether the quick start buttons should be displayed.
Accounting	If a billing system is connected, adjust settings for an accounting. You can choose between “Off”, “Normal billing”, and “Free operation”.
Date	Set the current date using the screen keyboard.
Time	Set the current time using the screen keyboard.
Access control setting	Set up of a prompt for a PIN code in order to dispense a product.

Display brightness	Set the display brightness.
Display brightness (standby)	Set the display brightness for stand-by mode.
Dispensing lighting	Set the brightness for the lighting of the dispensing area.
User interface	Select the visual style of the dispensing view from different presets and specify colors for the product buttons and the background of the dispensing view.
Screensaver	Select the screensaver.
Touch calibration	Calibrate the touch screen. To finish the calibration, press the center of the display.
User-defined localization	Adjust the decimal point and the thousands separator, the time and date format, or currency symbol to local requirements.

- Save your changes using the “Save” button.
 - Otherwise you will be prompted to confirm whether you want to discard the changes or whether you want to go back to save the changes.
- ✓ The machine settings have been changed.

7.7.4 Logging

- Press the “Logging” button (2) to display important events or error messages on the machine.
 - You can use the filter to display events according to various criteria.
- ✓ The log is displayed.

8 Cleaning

Clean the coffee machine carefully in accordance with the following specifications to maintain the value and hygiene of the machine.



Note

The following website provides all specific information on the machine and cleaning agents: www.planerhandbuch.de

8.1 Safety measures

▲ DANGER

Risk of fatal electric shock!

Contact with live parts poses a danger of death.

- Never open covers unless explicitly instructed to do so.
- Never remove bolts and the housing parts that they hold in place.
- Do not clean the machine or the installation area of the machine with a water jet, high-pressure cleaner, or steam cleaner.
- Never pour water over the machine.
- Only clean the machine with a damp cloth.

ATTENTION

Machine damage!

Water penetration can damage the machine and cause a short circuit.

- Do not clean the machine or the installation area of the machine with a water jet, high-pressure cleaner, or steam cleaner.
- Never pour water over the machine.
- Only clean the machine with a damp cloth.

7

8

8.2 Cleaning intervals

Interval	Which parts?	How to clean
After every use	Steam wand	Emit steam for approx. 2 seconds. Then clean with a clean, damp cloth.
Daily ^(1,2)	Milk and brewing system	Start cleaning program.
Daily	Instant system	Clean.
Daily	Coffee grounds drawer	Clean.
Daily	All systems/parts that have been used at least once	Clean with a clean, damp cloth.
1x weekly	Bottom of beverage outlet and bottom of milk foam wand	Clean with a clean, damp cloth; use a damp brush if necessary.
Following an extended standstill	Milk and brewing system	Start cleaning program.
As required	Mixer unit of instant system	Rinse mixer unit.
As required (at least once a month)	Bean and instant containers	Clean.
As required (at least once a month)	Housing parts <ul style="list-style-type: none"> • Surfaces, plastic parts, painted surfaces 	Clean externally with a clean, damp cloth.

⁽¹⁾ Twice a day for heavier use (more than 20 l of milk or more than 150 coffee products).

⁽²⁾ Once or twice a week an additional cleaning with AMC cleaner is required.

8.3 Cleaning prompt and dispensing lock

If cleaning is required (e.g., one of the programmed cleaning times has been exceeded), the cleaning prompt appears on the display. Products can then only be dispensed for a limited time or number of products.

If no cleaning work is carried out, product dispensing is then locked. The products are no longer displayed and cannot be dispensed.

To reset the cleaning prompt or dispensing lock, the machine must be cleaned.

8.4 Cleaning agents

Only use the cleaning agents listed as these are best suited to the automatic cleaning program:

- Melitta® Cafina® Multi TF-Tabs (art. no. 31547)
- Melitta® Cafina® AMC cleaner (art. no. 35289)

⚠ CAUTION

Damage to health due to cleaning agents!

The components in the cleaning agents may irritate eyes and skin, and may be harmful to health if inhaled or swallowed.

- Keep all information about the cleaning agents easily accessible in case of emergency.
- Always keep cleaning agents out of the reach of children.
- Only use the cleaning agents listed in the instructions, otherwise the legal warranty will become void.
- Wear gloves when handling cleaning tablets.
- Observe warning notes on the packaging of the cleaning agents.
- Observe the recommended usage quantity.

8.5 When using canisters

1. Empty both canisters daily.
 - Do not leave any water residue in the canisters; even fresh water quickly becomes contaminated.
2. Also observe the limit values for water carbonate hardness during canister operation.
 - Where necessary, the fresh water supply must be topped up via a water filter (e.g., BRITA-Purity).
3. Before filling, clean the fresh water canister and its lid area with standard dishwashing detergent and rinse off the cleaner residues thoroughly.
4. Also clean the waste water tank daily with detergent to prevent unpleasant odors forming due to organic waste in the waste water.
5. At least once a month clean the suction lance with detergent and rinse off the cleaner residues thoroughly.
 - Make sure that the filter insert in the intake piece at the bottom end of the suction lance is clean and free.
6. Ensure that the fresh water canister is filled with sufficient water and that the waste water canister is empty before you start the cleaning program.

8.6 Cleaning the coffee grounds drawer

The coffee grounds drawer must be cleaned daily if the coffee grounds are not disposed of via the optional container discharge.

1. Empty the coffee grounds drawer as described in chapter 5.6 on page 16.
 2. Clean the coffee grounds drawer.
 - Rinse the coffee grounds drawer with water.
 - Dishwasher cleaning is possible at max. 60 °C.
 3. Wipe the insert compartment of the coffee grounds drawer with a damp cleaning cloth.
 4. Reinsert the coffee grounds drawer.
 5. Follow the instructions on the display.
- ✓ The coffee grounds drawer has been cleaned.

8.7 Running the cleaning program

No products can be dispensed during the cleaning process. Product dispensing can be continued only after the cleaning program has been ended and all containers have been refitted.

▲ CAUTION

Danger of burns!

There is a danger of burns from hot components or due to hot liquids.

- Do not hold any body parts underneath the beverage outlet while the cleaning program is running or during the rinsing processes.
- Note that the water in the drip tray may be hot.

8.7.1 Preparatory activities (option)

The preparatory activities only have to be carried out when a milk system is present and has been used.

There will be one or two milk containers, cleaning containers, or milk tubes depending on the equipment.

1. Damp-clean all milk tubes coming out of the machine.
2. Clean the inside of the refrigerator (if fitted), the door, and door seals with a conventional cleaner.
 - Leave the door open during the entire cleaning process. Otherwise condensation could form and impair functioning.



Fig. 44: Cleaning container

3. Replace the milk container with the empty cleaning container (1).

8.7.2 Starting the cleaning program

The machine cleaning program runs to the greatest possible extent automatically.

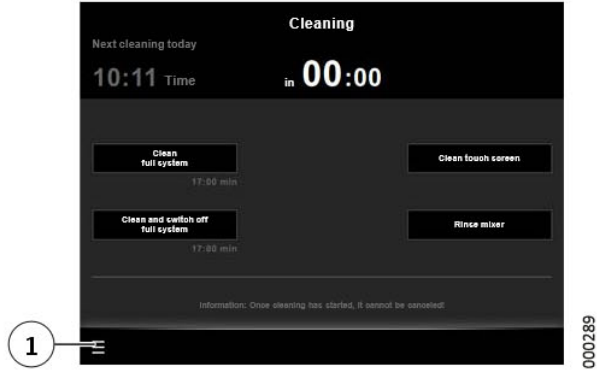

Fig. 45: Starting the cleaning program

1. On the display, press the menu symbol “≡” (1) and then “Cleaning”.
 - In self-service operation, you must first log in with a user chip key (see chapter 5.1.4 on page 10).
2. Select one of the following options:

Button	Function
Clean full system	Clean the milk and brewing system, then continue machine operation
Clean and switch off full system	Clean the milk and brewing system, then the machine switches off

3. Clean the coffee grounds drawer as described in chapter 8.6 on page 35.

If prompted to clean the instant system, clean the machine parts of the instant system as described in chapter 8.8 on page 39 and afterwards confirm that it has been fully reinstalled:

4. First confirm “Cleaning the instant system” and then “Instant system fully installed?” with the “OK” button.

8.7.3 Cleaning the milk system (option)

The milk system must be cleaned daily if it is fitted and used. Once or twice a week the cleaning program prompts for a cleaning with AMC cleaner. This causes acidic cleaning of the milk part and prevents limescale and milk particle deposits from forming.

8.7.3.1 Daily cleaning

The prompt “Cleaning agent milk system” is shown on the display.

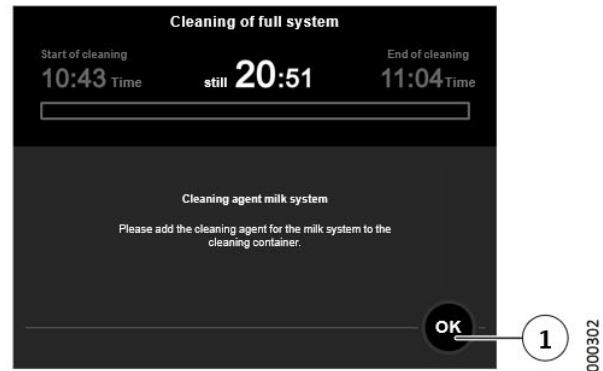

Fig. 46: Adding cleaning tablets

1. Insert one cleaning tablet (machines with top foam: two) into the prepared cleaning container.
2. Depending on the equipment, insert one or both milk tubes into the cleaning container.
 - Make sure that the milk tubes touch the bottom of the cleaning container.
3. Press the “OK” button (1) to confirm that the cleaning agent has been added.
4. Continue as described in chapter 8.7.4 on page 38.

8.7.3.2 Cleaning with AMC cleaner (machines without top foam)

If the system indicates to use the AMC cleaner, clean the machine as described in chapter 8.7.3.1 on page 36; however, instead of a cleaning tablet, fill a bag of AMC cleaner into the cleaning container.

8.7.3.3 Cleaning with AMC cleaner (machines with top foam)

Depending on the settings by customer service, the following options are available for this cleaning operation:

- Sequential request for cleaning agents (for one or two milk tubes)
- Simultaneous request for cleaning agents (for two milk tubes only)

Sequential request for cleaning agents

In this cleaning operation, the prompts for providing the cleaning agents occur one after the other, and between these prompts a cleaning process is carried out.

The prompt “Cleaning agent milk system” is shown on the display (see Fig. 46).

1. Carry out the cleaning as described in chapter 8.7.3.1 on page 36 until it is confirmed that the cleaning agent has been added.

The prompt “Cleaning agent brewing system” is shown on the display.

2. Carry out the cleaning as described in chapter 8.7.4 on page 38 until it is confirmed that the cleaning agent has been added.
 - The machine starts the first automatic cleaning process.
 - The cleaning process takes a few minutes.

The prompt “Cleaning agent milk system” is then shown on the display again.

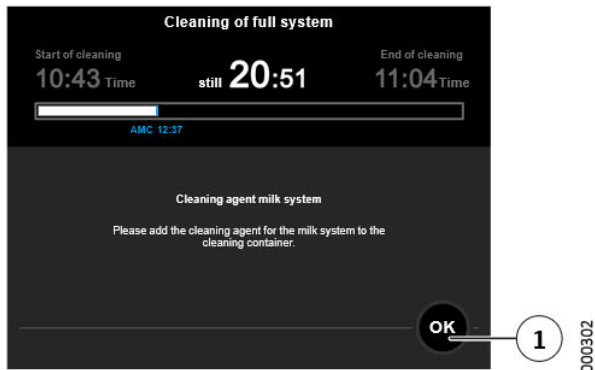

Fig. 47: Adding the AMC cleaner

3. Fill a bag of AMC cleaner into the cleaning container.
4. Depending on the equipment, insert one or both milk tubes into the cleaning container.
 - Make sure that the milk tubes touch the bottom of the cleaning container.
5. Press the “OK” button (1) to confirm that the cleaning powder has been added.
 - The machine starts the second automatic cleaning process.
 - The cleaning process takes a few minutes.

The machine is then switched off or, depending on the selection, it goes back to operational readiness mode.

6. Continue as described in chapter 8.7.5 on page 39.

Simultaneous request for cleaning agents

The machine must have two milk tubes for this cleaning operation. The cleaning agents are supplied simultaneously in two cleaning containers (white and blue). This way, the cleaning process will be performed at a single stretch without intermission.

The prompt “Cleaning agent milk system” is shown on the display.

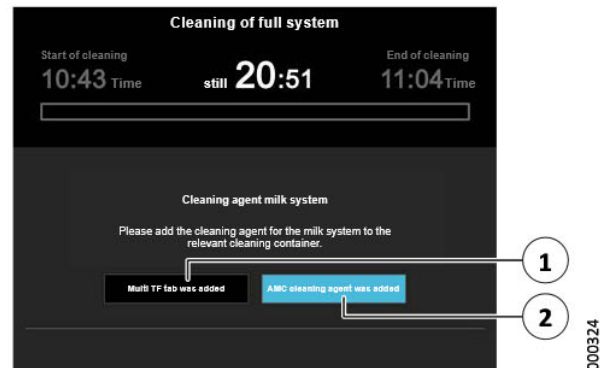

Fig. 48: Adding the cleaning agent

1. Insert two cleaning tablets into the prepared white cleaning container.
2. Insert the white milk tube into the white cleaning container.
 - Make sure that the milk tube touches the bottom of the cleaning container.



Fig. 49: White cleaning container with milk tube

000701

3. Press the “Multi TF-tab was added” button (1) (see Fig. 48) to confirm that the cleaning agent has been added.
4. Fill a bag of AMC cleaner into the blue cleaning container.
5. Insert the blue milk tube into the blue cleaning container.
 - Make sure that the milk tube touches the bottom of the cleaning container.



Fig. 50: Blue cleaning container with milk tube

000702

6. Press the “AMC cleaning agent was added” button (2) (see Fig. 48) to confirm that the cleaning powder has been added.
7. Continue as described in chapter 8.7.4 on page 38.

8.7.4 Cleaning the brewing system

The prompt “Cleaning agent brewing system” is shown on the display.



Fig. 51: Tab holder

000703

1. Open the machine door using the key.
2. Remove the tab holder (1) with a quarter turn counterclockwise.

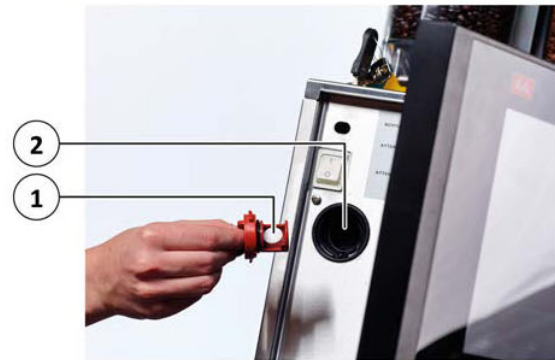

Fig. 52: Cleaning tablet

000706

3. Put a cleaning tablet (1) into the tab holder.
4. Turn the tab holder a quarter turn clockwise firmly back into the machine (2).
5. Close the machine door.

6. Press the “OK” button to confirm that the cleaning tablet has been added.
 - The machine starts the automatic cleaning process.
 - The cleaning process takes a few minutes.



Note

The touch screen can be cleaned while the cleaning program is running without the need to deactivate the display for inputs beforehand (see also chapter 8.12 on page 42).

The machine is then switched off or, depending on the selection, it goes back to operational readiness mode.

8.7.5 Final activities

1. Clean the dispensing area once the automatic cleaning process is complete (see chapter 8.13 on page 43).
 2. If you want to continue using the machine, refill the milk as described in chapter 5.4.3 on page 14.
- ✓ The cleaning is complete.

8.8 Cleaning the instant system



Fig. 53: Removing the instant system cover

1. Open the instant system cover with the key (2).
2. Remove the cover (1) by pulling it forwards.
3. Carry out the steps as described below.

Removing the mixer unit

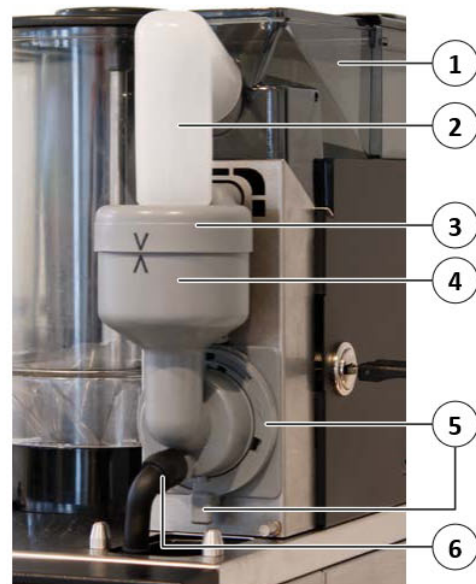

Fig. 54: Mixer unit

1. Remove the powder chute (2) from the instant container (1).

2. Remove the tube (6) on the mixer housing and on the beverage outlet.
3. Turn the mixer flange (5) counterclockwise as far as it will go.
4. Remove the entire mixer housing (4) towards the front.
5. Remove the cover (3).

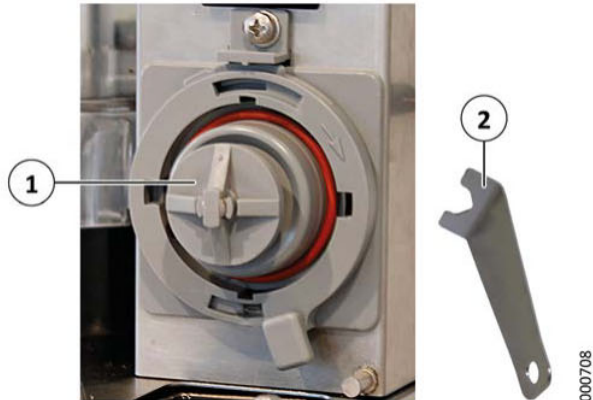

Fig. 55: Removing the mixer wheel

6. Remove the mixer wheel (1) from the axle either by hand or using the removal tool (2) provided.

✓ The mixer unit has been removed.

Cleaning the mixer unit and powder chutes

1. Remove rough dirt with water and a brush.
2. To clean the mixer unit and powder chutes, proceed with one of the following options:
 - Clean all parts in a dishwasher at a maximum of 60 °C.
 - Clean all parts thoroughly with hot water and a cleaner suitable for milk products.
 - Rinse all parts thoroughly with clean water.
3. Dry the parts completely.
 - To prevent the instant powder from forming clumps, the parts must be absolutely dry.
4. Damp-clean the area around the axle.
 - This is the area where the mixer wheel is located.

✓ The mixer unit has been cleaned.

Assembling the mixer unit

Assembly is carried out by reversing the order of the removal process.

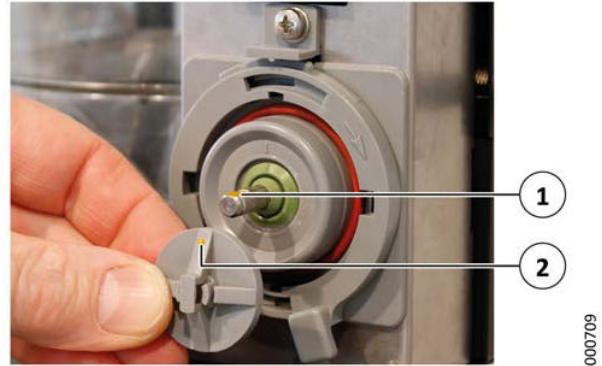

Fig. 56: Fitting the mixer wheel

1. Insert the mixer wheel onto the axle as far as it will go.
 - Ensure that the flattened side (1) matches up with the marking (2) on the mixer wheel.



Fig. 57: Mixer unit

2. Refit the cover (3).
3. Fit the mixer housing (4).

4. Turn the mixer flange (5) clockwise as far as it will go.
 5. Fit the tube (6) fully onto the nozzle of the mixer unit and the beverage outlet.
 - Check that the tube is fitted securely.
 6. Fit the powder chute (2) so that it is pointing upwards.
 - Do not reach into the cleaned powder chute with your fingers.
 7. Fit the instant container (1) onto the machine.
 8. Turn the powder chute downwards to direct it into the mixer housing.
 9. Clean the area of the instant system from instant powder and residues.
 - Make sure that the drain hole in the bottom below the mixer unit is free.
- ✓ The mixer unit has been installed.

8.9 Rinsing the mixer unit

If necessary, e.g., if instant powder has found its way into the mixer housing, you should clean the mixer unit.

CAUTION

Danger of burns on the beverage outlet!

Hot water runs out of the beverage outlet when the mixer unit is rinsed.

- Do not reach underneath the outlets.

1. Make sure that the instant system is fully installed.
2. On the display, press the menu symbol “☰” (1) (see Fig. 45) and then “Cleaning”.
 - In self-service operation, you must first log in with a user chip key (see chapter 5.1.4 on page 10).
3. Press the “Rinse mixer” button.

- ✓ The mixer unit is rinsed.

Note

If the instant system cover has been removed for more than ten seconds, a prompt to confirm whether or not the mixer unit should be rinsed appears on the display once the cover has been reinstalled. Rinse the mixer unit if required by pressing the “Yes” button.

8.10 Cleaning the bean container

There will be one or two bean containers depending on the equipment.



Fig. 58: Removing the bean container

1. Remove the lid on the bean container.
2. Turn the lever (1) a ¼ turn counterclockwise.
3. Remove the bean container (2).
4. Empty the bean container.
5. Clean all parts thoroughly with hot water and a detergent.
 - Dishwasher cleaning is possible at max. 60 °C.
6. Dry the parts completely.
7. If you want to continue using the machine, refill the beans as described in chapter 5.4.1 on page 13.

- ✓ The bean container has been cleaned.

8.11 Cleaning the instant container



Fig. 59: Removing the instant system cover

1. Open the instant system cover with the key (2).
2. Pull the cover (1) forwards.

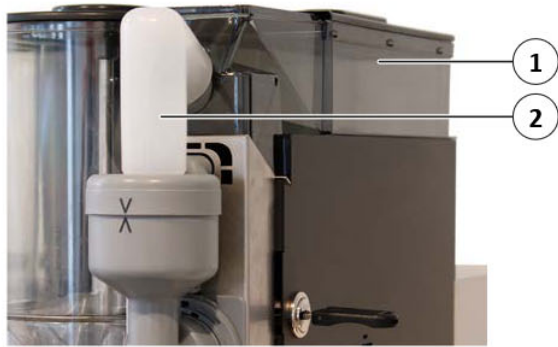

Fig. 60: Instant container

3. Turn the powder chute (2) upwards so that no powder can fall out.
4. Remove the instant container (1).
5. Empty the instant container.
6. Clean all parts thoroughly with hot water and a detergent.
 - Dishwasher cleaning is possible at max. 60 °C.
7. Dry the parts completely.
 - To prevent the instant powder from forming clumps, the parts must be absolutely dry.
8. If you want to continue using the machine, refill the instant powder as described in chapter 5.4.2 on page 14.

✓ The instant container has been cleaned.

8.12 Cleaning the touch screen

Cleaning is required if there is any visible dirt.

1. On the display, press the menu symbol “≡” (1) (see Fig. 45) and then “Cleaning”.
 - In self-service operation, you must first log in with a user chip key (see chapter 5.1.4 on page 10).
2. Press the “Clean touch screen” button.
 - The display is now blocked for inputs.
3. Clean the screen with a microfiber cloth or a damp cloth.
 - If you use a damp cloth, make sure that the touch screen is completely dry and free of streaks before you continue using the unit.
4. After cleaning, enable the display for inputs again by touching the numbers 1-4 in the corners of the display.

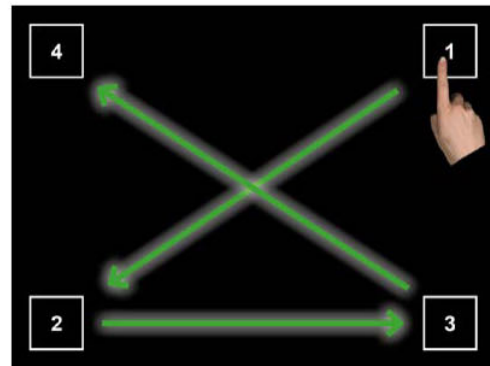

Fig. 61: Cleaning the touch screen

✓ The cleaning of the touch screen is complete.

8.13 External cleaning



Note

Do not use any abrasive agents or sharp objects.

- Clean the parts with a clean, damp cloth only.

1. Wipe down the plastic parts, painted surfaces, and surfaces with a damp cloth.



Fig. 62: External cleaning

2. Clean the bottom of the beverage outlet (2) thoroughly with a clean, damp cloth, and a standard, damp brush if necessary.
3. Remove the drip grid (3).

▲ CAUTION

Risk of scalding!

The water in the drip tray may still be hot.

- Allow the water to cool down.

4. Wipe the drip tray (1) thoroughly.

- ✓ The external cleaning is complete.

9 Maintenance

If you have any questions concerning service, maintenance, or disposal, please contact your official dealer. Repairs and maintenance may only be carried out by Melitta customer service or by specialist personnel authorized by the manufacturer.

When contacting, have the following details from the nameplate (inside of the grounds drawer door) at hand:

- Type/Typ
- Serial no./Geräte-Nr.

9.1 Intervals

After every 45,000 cups or twelve months of operation (whichever occurs first), the machine and all accessory units must be serviced by customer service (for a fee).

- Ensure that the maintenance work date is scheduled in due time to avoid unnecessary wear.
- Observe the intervals given in the manufacturer's instructions for changing the filter.
- Replace the water filter every twelve months at the latest to prevent germs and water contamination.

On request, the manufacturer offers a comprehensive maintenance contract that also ensures that all inspection and maintenance intervals are observed.

By law, commercial operators are required to have their systems inspected by an authorized electrical engineer once every four years to make sure that everything is in order. These inspections must be performed and documented accordingly. Customer service can take care of this for you and certify that everything has been completed correctly (no other inspection is required prior to initial commissioning).

9.2 Faults

In the event of faults, have the unit inspected and, where applicable, repaired by customer service before you start using it again. Incorrectly performed repair work can result in considerable risk to the user.

▲ WARNING

Malfunctions!

If there are visible signs of damage or any obvious malfunctions, some key safety functions might not be working properly.

Obvious malfunctions include water leaks, odors, and heat formation, as well as error messages on the display.

In the event of a malfunction:

- Disconnect the mains plug.
 - Switch off the water supply.
 - Have the machine checked and repaired by customer service.
-

10 Recycling and disposal

This machine has been designed and manufactured to allow environmentally friendly disposal.

10.1 Waste disposal

The waste produced during brewing is purely organic and can therefore be disposed of in normal household waste.

10.2 Waste water disposal

The waste water produced during the brewing and cleaning processes complies with the definitions of general domestic waste water and can therefore be drained into the normal sewerage system.

10.3 Disposal of cleaning agents

The cleaning agents recommended in these instructions conform to legal requirements when used correctly and can therefore be drained into the normal sewerage system with the rinse water without further measures.

10.4 Disposal of the machine

This machine contains high-quality raw materials that should be recycled.



Do not dispose of equipment in domestic waste!

During disposal, observe the appropriate national and regional laws and guidelines.



Melitta Professional Coffee Solutions GmbH & Co. KG • Zechenstraße 60 • 32429 Minden • GERMANY
Phone: +49 571 5049-0 • Fax: +49 571 5049-233 • professional@melitta.de • www.melitta-professional.de

® Registered trademark of a company of the Melitta Group • 20220101 • Art. no. 39246