

**Revision:**

- PARTS LIST have been partially modified.
- Please void OB311.

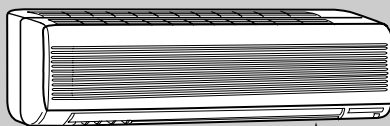
**No. OB311**  
REVISED EDITION-A

# SERVICE MANUAL

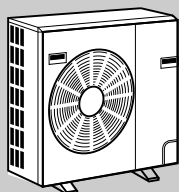
**Wireless type  
Models**

**MS24WN (w)**

**· MU24WN**



INDOOR UNIT  
Indication of model name  
MS24WN



OUTDOOR UNIT  
Indication of model name  
MU24WN



Remote  
controller

## CONTENTS

1. FEATURES .....	3
2. PART NAMES AND FUNCTIONS .....	4
3. SPECIFICATION .....	6
4. DATA .....	8
5. OUTLINES AND DIMENSIONS .....	12
6. WIRING DIAGRAM .....	14
7. REFRIGERANT SYSTEM DIAGRAM .....	15
8. MICROPROCESSOR CONTROL .....	16
9. SERVICE FUNCTIONS .....	25
10. TROUBLESHOOTING .....	27
11. DISASSEMBLY INSTRUCTIONS .....	40
12. PARTS LIST .....	44
13. OPTIONAL PARTS .....	BACK COVER



The Slim Line.  
From Mitsubishi Electric.

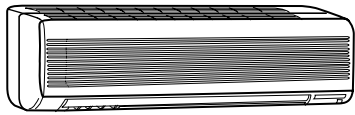


**Mr. SLIM™**

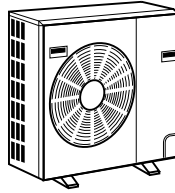
**Revision:**

- Parts No. has been changed due to the color change of outdoor unit parts. WHITE→NEW WHITE (Brighter)
- Capillary tube has been added to parts list.

<b>Model</b>	<b>Page</b>	<b>Part name</b>	<b>Part number</b>
<b>MU24WN</b>	47	CAPILLARY TUBE (TAPER PIPE) $\phi 0.14 \times \phi 0.09 \times 1-31/32$	E02 784 936



MS24WN

LCD wireless  
remote controller

MU24WN

Model	Cooling capacity	SEER
MS24WN	22,800 Btu/h	10.5

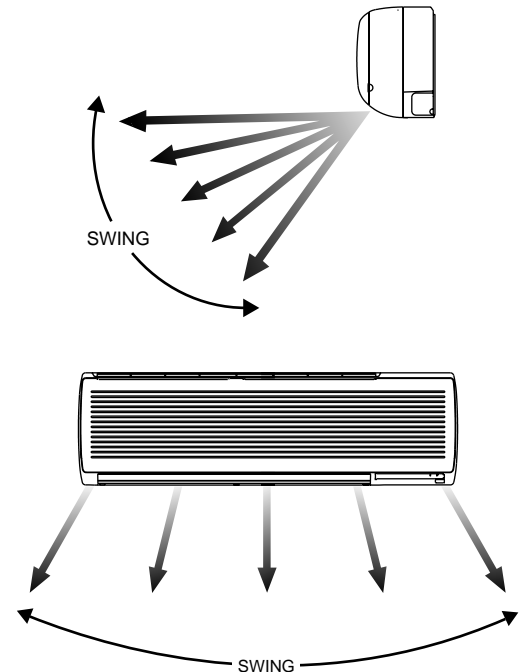
### “I FEEL CONTROL” IN OUR LCD WIRELESS REMOTE CONTROLLER WITH ON/OFF PROGRAM TIMER

Mitsubishi Electric's new wireless remote controller incorporates a number of advanced features that provide even greater control and ease-to-use. It has a liquid crystal display which indicates such information as mode, fan speed and temperature selected as well as the programmed ON/OFF timer. It is also equipped with “I Feel Control”, a unique Mitsubishi Electric feature that allows the user to adjust the temperature to exactly the level he or she wants simply by tapping the button that describes present conditions : “Too Cool” or “Too Warm”. The optimum temperature set this way is then memorized for immediate recall whenever the air conditioner is used again.

#### Select desired air flow direction.

#### REMOTE-CONTROL OPERATION MODE

Using the remote controller, you can select from five airflow settings to match room layout and the location of people. Also, you can set the vane to swing automatically.

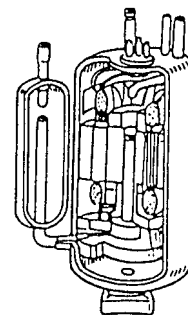


#### AUTO-RESTART FUNCTION

The auto restart function restarts the equipment automatically when power is restored following an outage. Operation resumes in the mode in which the equipment was running just before the outage.

#### HIGH PERFORMANCE ROTARY COMPRESSOR

The advanced design of Mitsubishi Electric's powerful and energy efficient rotary compressor results in lower operating costs and longer service life.

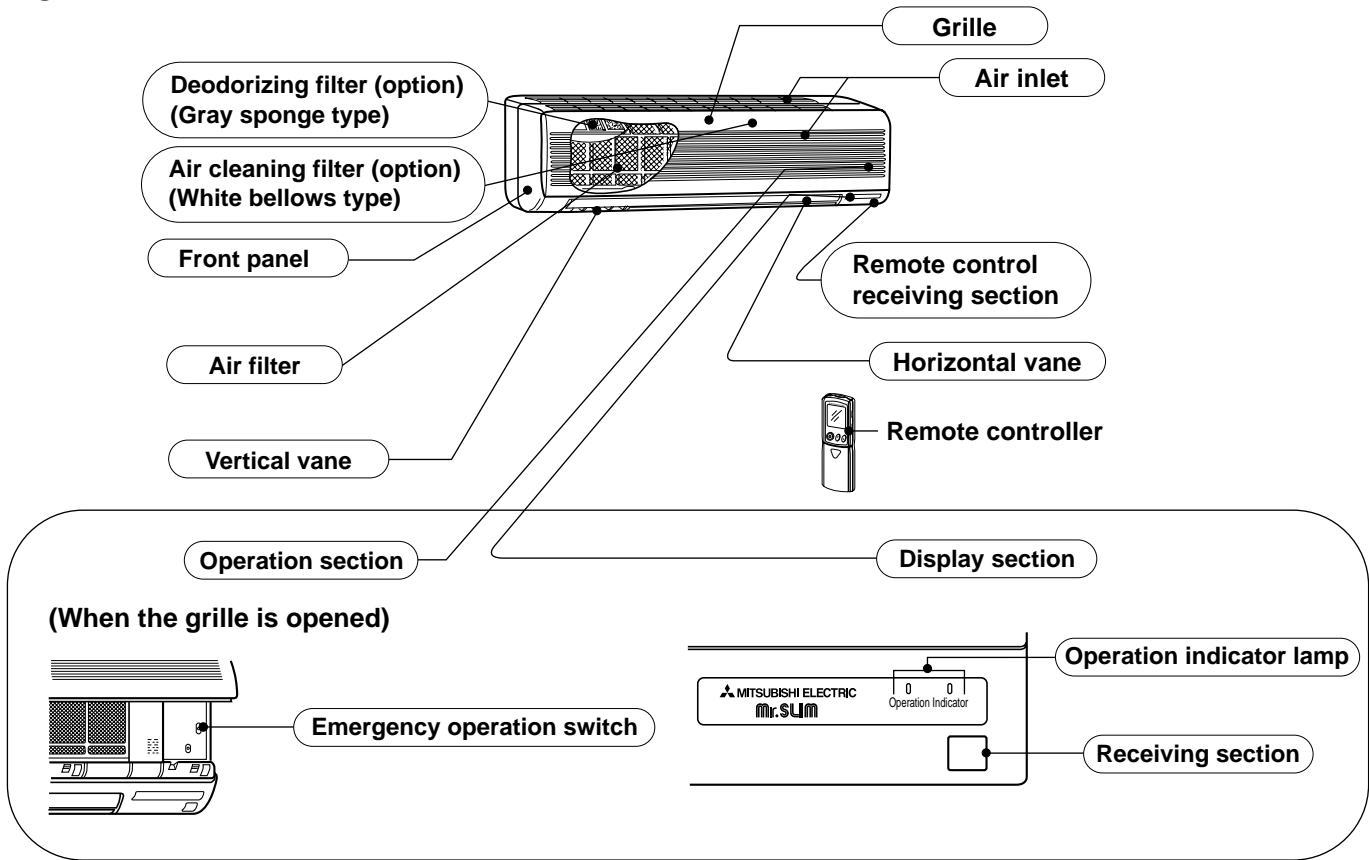


## 2

# PART NAMES AND FUNCTIONS

### INDOOR UNIT

MS24WN

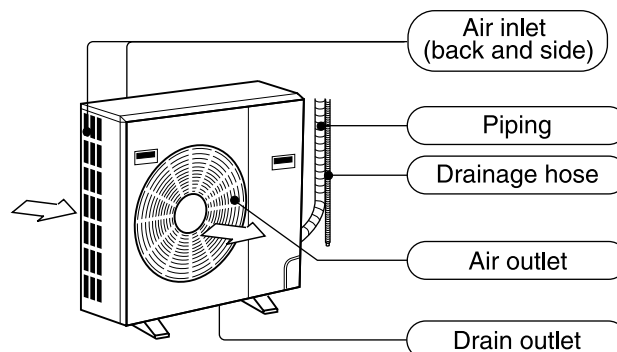


### ACCESSORIES

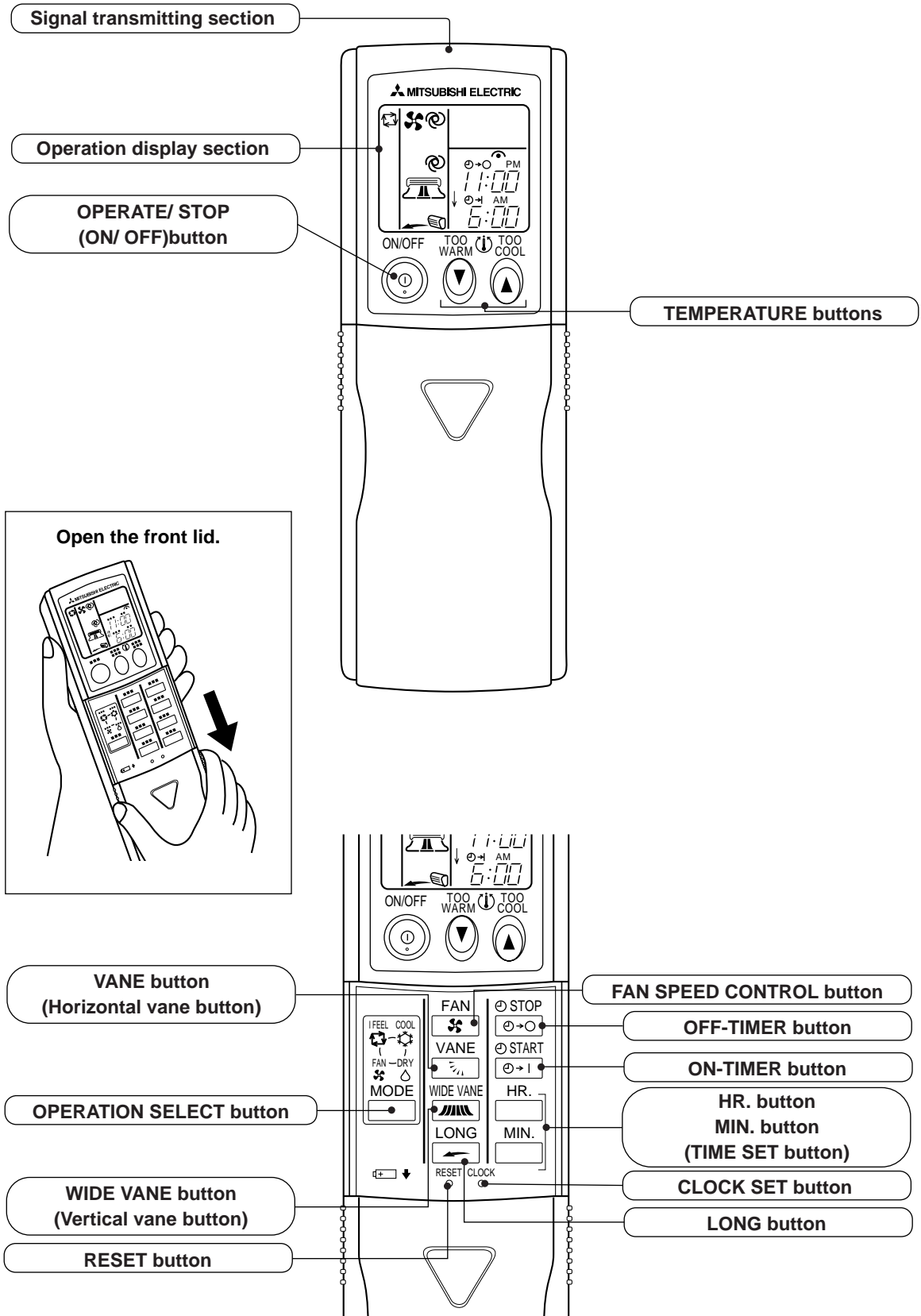
		MS24WN
①	Installation plate	1
②	Installation plate fixing screw 4 x 25 mm(0.16 x 0.98 in.)	7
③	Remote controller holder	1
④	Fixing screw for ③ 3.5 x 16 mm(0.14 x 0.63 in.) (Black)	2
⑤	Battery (AAA) for remote controller	2
⑥	Wireless remote controller	1
⑦	Felt tape (Used for left or left-rear piping)	1

### OUTDOOR UNIT

MU24WN



# REMOTE CONTROLLER MS24WN



# 3

# SPECIFICATION

Item	Model	MS24WN
Cooling capacity *1	Btu/h	22,800
Power consumption *1	W	2,170
EER *1 [SEER] *2		10.5 (10.5)
INDOOR UNIT MODEL		MS24WN
External finish		White
Power supply		115V 60Hz 1 $\phi$
Max. fuse size (time delay)/ Disconnect switch	A	15
Min. ampacity	A	1.1
Fan motor	F.L.A	0.82
Airflow Low—Med.—High	FAN Dry	CFM 431-491-565
	COOL Dry(Wet)	CFM 402(346)-484(417)-565(487)
Moisture removal	pt./h	7.6
Sound level Low-Med.-High	dB(A)	39-43-47
Cond. drain connection O.D.	in.	5/8
Dimensions	W	in. 43-5/16
	D	in. 8-15/16
	H	in. 12-13/16
Weight	lb.	40
OUTDOOR UNIT MODEL		MU24WN
External finish		Munsell 5Y7/1
Power supply		208/230V 60Hz 1 $\phi$ 3 wires
Max. fuse size (time delay)	A	25
Min. ampacity	A	22
Fan motor	F.L.A	0.87
Compressor	Model	PH33NPBT
	Winding resistance (at 68°F) $\Omega$	C-R 0.84 C-S 2.09
	R.L.A	16
	L.R.A	58
Refrigerant control		Linear expansion valve
Sound level	dB(A)	55
Dimensions	W	in. 34-1/4
	D	in. 11-5/8
	H	in. 33-1/2
Weight	lb.	152
REMOTE CONTROLLER		Wireless type
Control voltage (by built-in transformer)		12V DC
REFRIGERANT PIPING		Not supplied (optional parts)
Pipe size (Min. wall thickness)	Liquid	in. 3/8 (0.0285)
	Gas	in. 5/8 (0.0315)
Connection method	Indoor	Flared
	Outdoor	Flared
Between the indoor & outdoor units	Height difference	ft. Max. 25
	Piping length	ft. Max. 50
Refrigerant charge (R22)		4 lb. 5 oz.
Refrigerant oil (Model)	oz.	27.9 (MS32N1)

Notes : Test conditions are based on ARI 210/240

\*1 : Rating conditions (cooling) — Indoor : 80°FDB, 67°FWB, Outdoor : 95°FDB, (75°FWB)

\*2 : Rating conditions (cooling) — Indoor : 80°FDB, 67°FWB, Outdoor : 82°FDB, 65°FWB

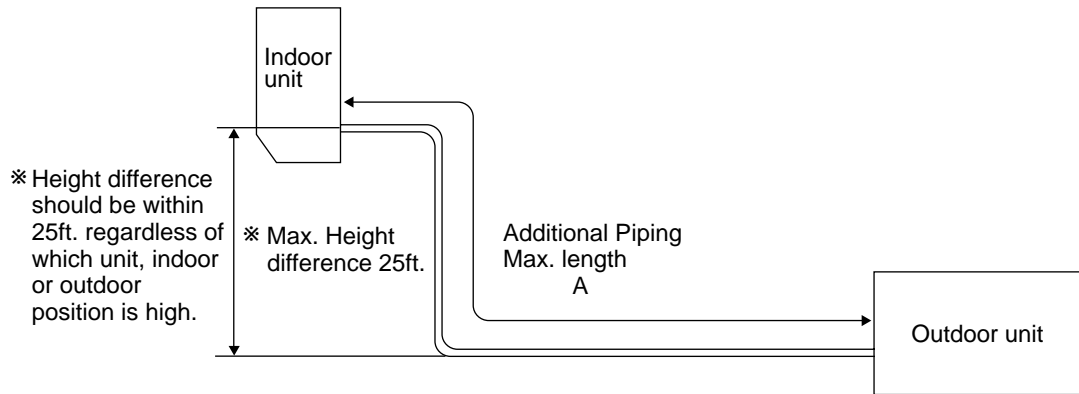
## Operating Range

		Indoor intake air temperature	Outdoor intake air temperature
Cooling	Maximum	95°FDB, 71°FWB	115°FDB
	Minimum	67°FDB, 57°FWB	67°FDB

## MAX. REFRIGERANT PIPING LENGTH & MAX. HEIGHT DIFFERENCE

Model	Additional piping Max. length : ft. A	Piping size : in.				Length of connecting pipe : in.	
		Gas		Liquid		Indoor unit	Outdoor unit
		Outside diameter	Minimum Wall thickness	Outside diameter	Minimum Wall thickness		
MS24WN MU24WN	50	φ 5/8	0.0315	φ 3/8	0.0285	Gas : 16-15/16 Liquid : 19-11/16	Gas : 0 Liquid : 0

## MAX. HEIGHT DIFFERENCE



4-1. PERFORMANCE DATA

1) COOLING CAPACITY

MS24WN MU24WN

(208V/ 230V)

Model	Indoor air IWB (°F)	Outdoor intake air DB temperature(°F)														
		75			85			95			105			115		
		TC	SHC	TPC	TC	SHC	TPC	TC	SHC	TPC	TC	SHC	TPC	TC	SHC	TPC
MS24WN	71	27.9	13.9	1.93	26.1	13.0	2.12	24.5	12.2	2.28	22.8	11.3	2.40	21.0	10.4	2.50
	67	26.4	16.7	1.82	24.6	15.5	2.01	22.8	14.4	2.17	21.2	13.4	2.30	19.5	12.3	2.41
	63	24.9	19.0	1.74	23.0	17.6	1.92	21.4	16.4	2.07	19.5	14.9	2.21	17.8	13.6	2.30

Notes 1. IWB : Intake air wet-bulb temperature.

TC : Total Capacity (x10<sup>3</sup> Btu/h), SHC : Sensible Heat Capacity (x10<sup>3</sup> Btu/h)

TPC : Total Power Consumption (kW)

2. SHC is based on 80°F of indoor intake air DB temperature.

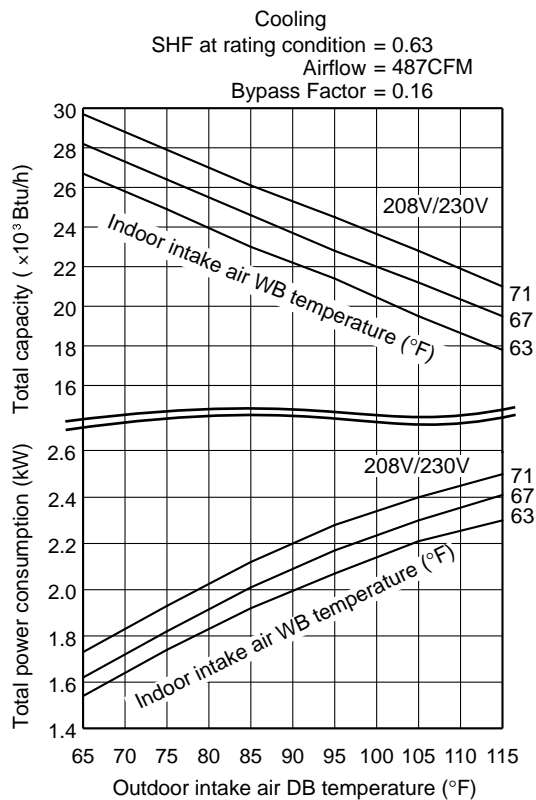
2) COOLING CAPACITY CORRECTIONS

Model	Refrigerant piping length (one way)		
	25ft. (std.)	40ft.	50ft.
MS24WN	1.0	0.954	0.923

4-2. PERFORMANCE CURVE

MS24WN

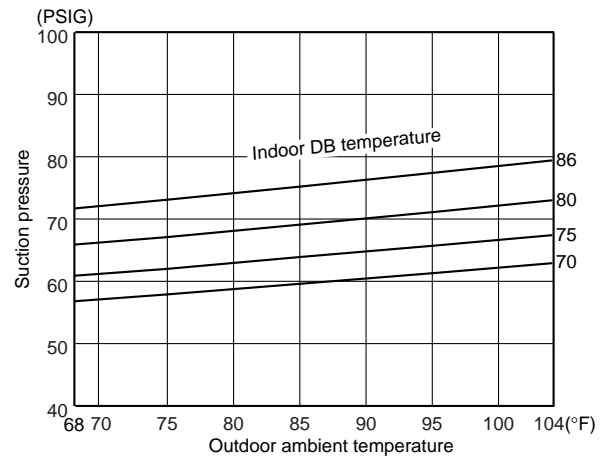
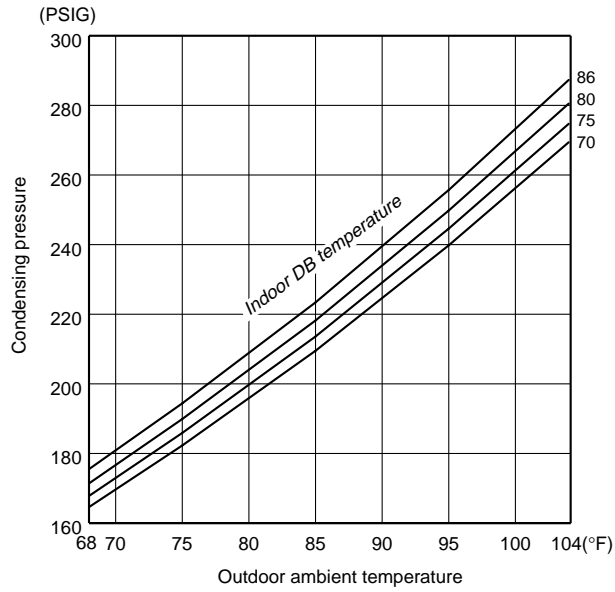
MU24WN



### 4-3. Condensing pressure

Data is based on the condition of indoor humidity 50%.  
Air flow should be set at High.

#### MU24WN

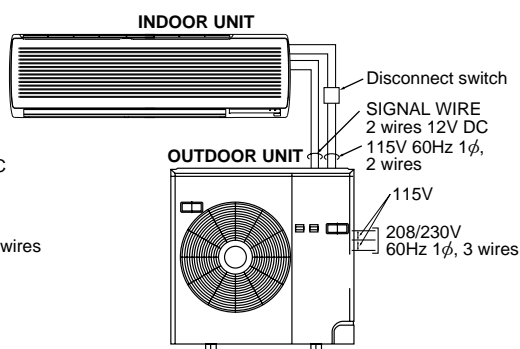
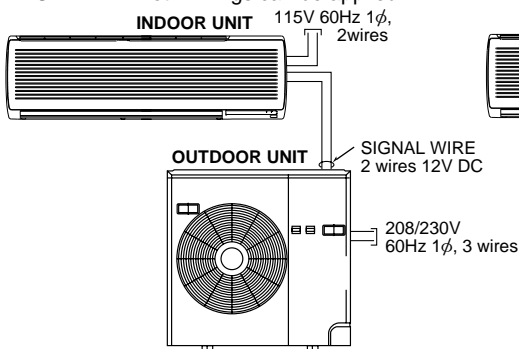


#### 4-4. STANDARD OPERATION DATA

Model			MS24WN	
Item		Unit	Cooling	
Total	Capacity	Btu / h	22,800	
	SHF	—	0.63	
	Input	kW	2.17	
Electrical circuit	INDOOR UNIT MODEL		MS24WN	
	Power supply		115V 60Hz 1 $\phi$	
	Input	kW	0.071	
	Fan motor current	A	0.62	
	OUTDOOR UNIT MODEL		MU24WN	
	Power supply		208/230V 60Hz 1 $\phi$	
	Input	kW	2.099	
	Comp. current	A	9.36/ 8.30	
	Fan motor current	A	0.67/0.71	
Refrigerant circuit	Condensing pressure	PSIG	250	
	Suction pressure	PSIG	71	
	Discharge temperature	$^{\circ}$ F	174	
	Condensing temperature	$^{\circ}$ F	115	
	Suction temperature	$^{\circ}$ F	48	
	Comp. shell bottom temp	$^{\circ}$ F	158	
	Ref. pipe length	ft.	25	
	Refrigerant charge (R22)	—	4 lb. 5 oz.	
Indoor unit	Intake air temperature	DB	$^{\circ}$ F	80
		WB	$^{\circ}$ F	67
	Discharge air temperature	DB	$^{\circ}$ F	51
		WB	$^{\circ}$ F	50
	Fan speed (High)	rpm	1,280	
	Airflow (High)	CFM	487(Wet)	
Outdoor unit	Intake air temperature	DB	$^{\circ}$ F	95
		WB	$^{\circ}$ F	—
	Fan speed	rpm	750/820	
	Airflow	CFM	1,589/1,765	

#### POWER SUPPLY

MS24WN •Both wirings can be applied.



\* Control voltage

Power supply voltage to serial signal circuit is 12V DC. Voltage between ①+ and ③- on in-out terminal block will be 12V DC peak.

## 4-5. OPERATING RANGE

### (1) POWER SUPPLY

	Model	Rating	Guaranteed Voltage
Indoor unit	MS24WN	115V 60Hz 1 $\phi$	Min. 103V 115V Max. 127V ----- ----- ----- -----
Outdoor unit	MU24WN	208/230V 60Hz 1 $\phi$	Min. 198V 208V 230V Max. 253V ----- ----- ----- -----

### (2) OPERATION

Function	Intake air temperature Condition	Indoor		Outdoor	
		DB (°F)	WB (°F)	DB (°F)	WB (°F)
Cooling	Standard temperature	80	67	95	—
	Maximum temperature	95	71	115	—
	Minimum temperature	67	57	67	—
	Maximum humidity	78%		—	

## 4-6. OUTLET AIR SPEED AND COVERAGE RANGE

Model	Mode	Function	Air flow (CFM)	Air speed (ft./sec.)	Coverage range (ft.)
MS24WN	FAN COOL	Dry	565	20.1	34.2
		Wet	487	17.2	29.4

- The air coverage range is the figure up to the position where the air speed is 1 ft./sec., when air is blown out horizontally from the unit properly at the High speed position.  
The coverage range should be used only as a general guideline since it varies according to the size of the room and furniture arranged in the room.

## 4-7. ADDITIONAL REFRIGERANT CHARGE (R22(oz.))

Model	Outdoor unit precharged (up to 25ft.)	Refrigerant piping length (one way)					
		25ft.	30ft.	35ft.	40ft.	45ft.	50ft.
MS24WN MU24WN	4 lb. 5 oz.	0	0.81	1.62	2.43	3.24	4.05

CALCULATION : Xoz. = 0.81/ 5oz./ft. x (Additional Piping Length-25) ft.

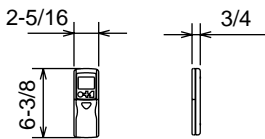
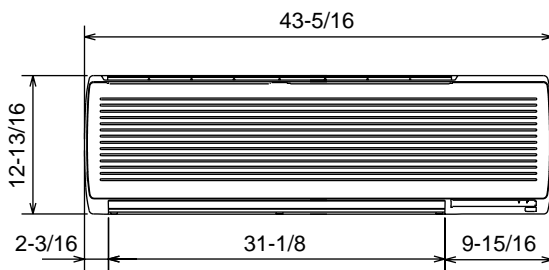
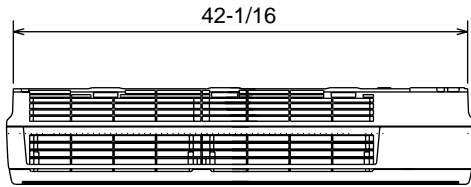
5

**OUTLINES AND DIMENSIONS**

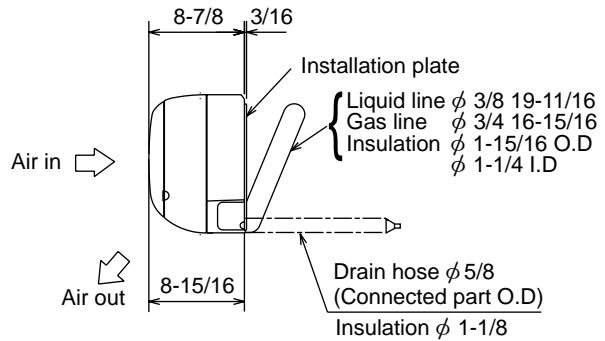
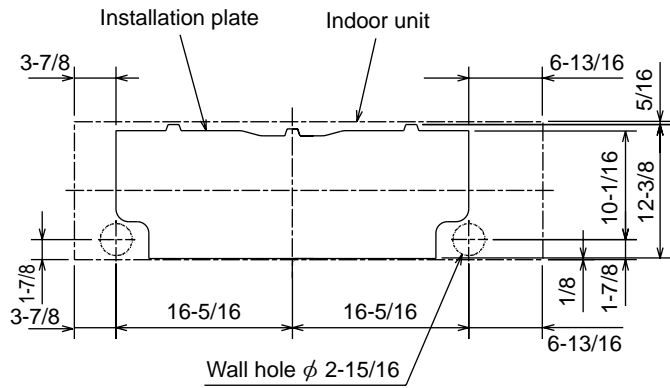
**MS24WN**

**Unit: inch**

**INDOOR UNIT**



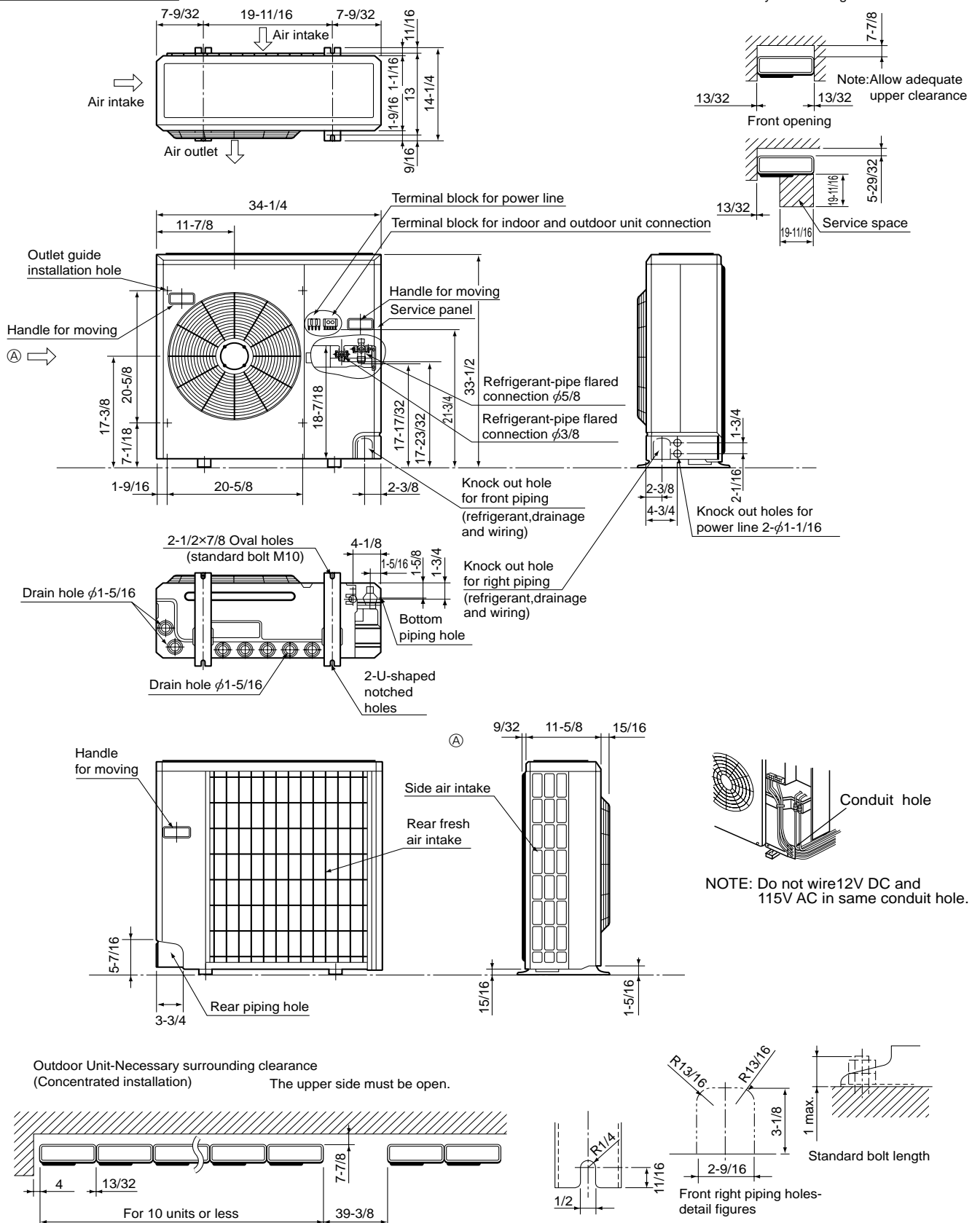
Wireless remote controller



# MU24WN

## OUTDOOR UNIT

Unit: inch





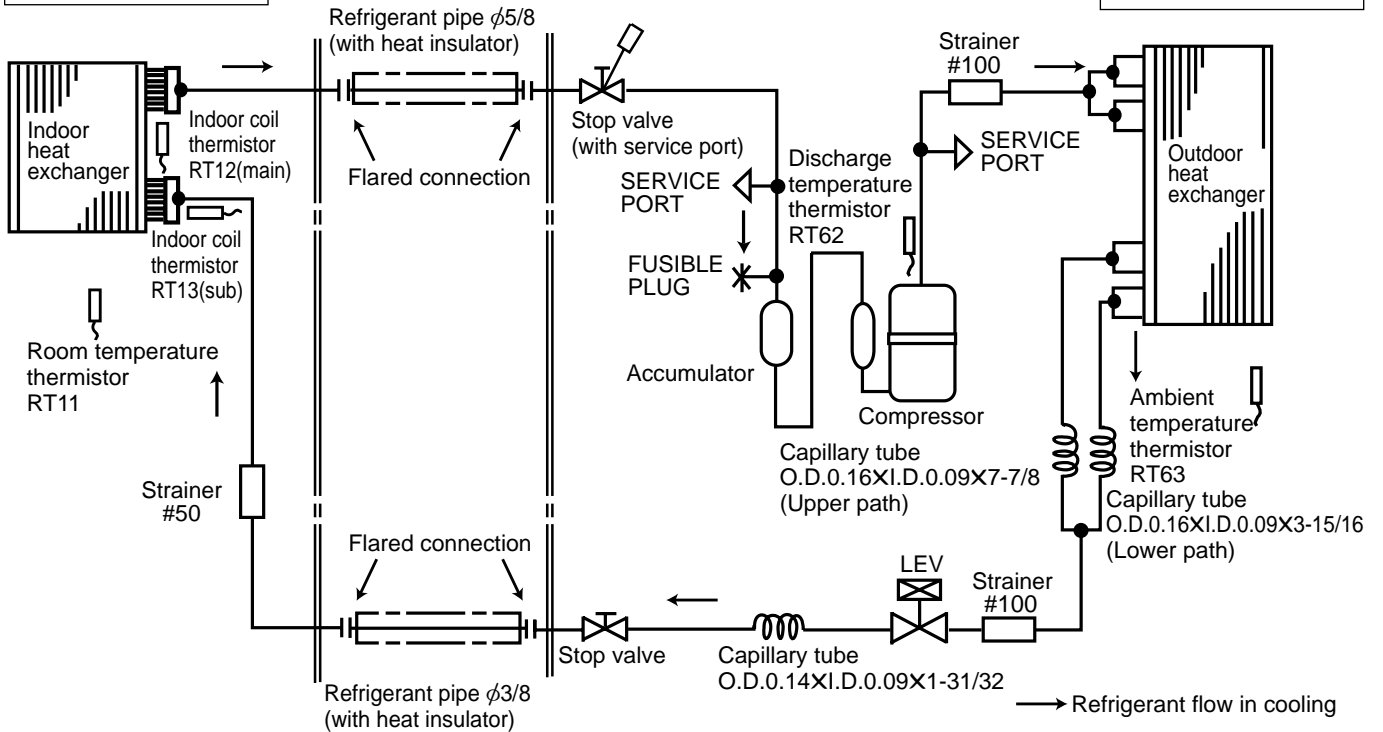
Unit: inch

MS24WN

INDOOR UNIT

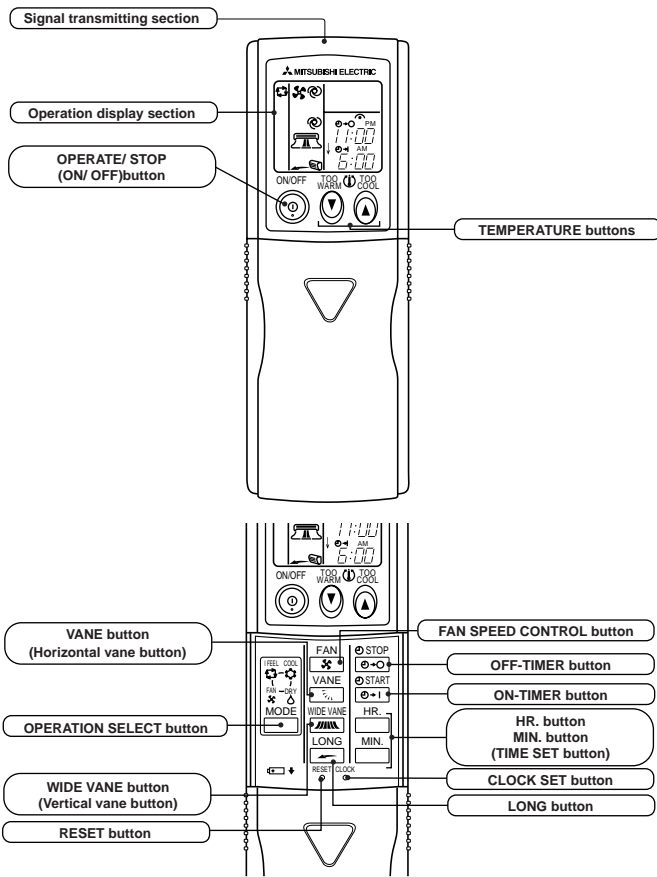
MU24WN

OUTDOOR UNIT



## MS24WN MU24WN

### WIRELESS REMOTE CONTROLLER



Once the operation mode is set, the same operation mode can be repeated by simply turning the OPERATE/STOP(ON/OFF) button ON. Indoor unit receives the signal with a beep tone. When the system turns off, 3-minute time delay will operate to protect system from overload and compressor will not restart for 3 minutes.

### 8-1. "I FEEL CONTROL" (□) OPERATION

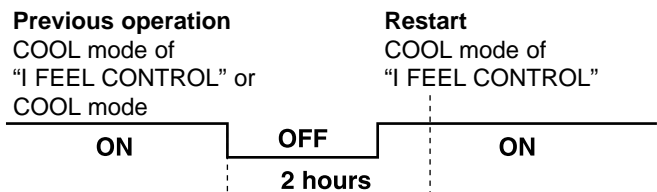
- (1) Press OPERATE/STOP(ON/OFF) button on the remote controller. OPERATION INDICATOR lamp of the indoor unit turns on with a beep tone.
- (2) Select "I FEEL CONTROL"(□) mode with the OPERATION SELECT button.
- (3) The operation mode is determined by the room temperature at start-up of the operation.

Initial room temperature	mode
77°F or more	COOL mode of "I FEEL CONTROL"
more than 55°F, less than 77°F	DRY mode of "I FEEL CONTROL"

- Once the mode is fixed, the mode does not change by room temperature afterwards.
- Under the ON-TIMER (⊕→|) operation, the mode is determined according to the room temperature at the set time the operation starts.
- When the system is stopped on the remote controller, and restarted within 2 hours in "I FEEL CONTROL" (□) mode, the system operates in previous mode automatically regardless of the room temperature.

#### Operation timer chart

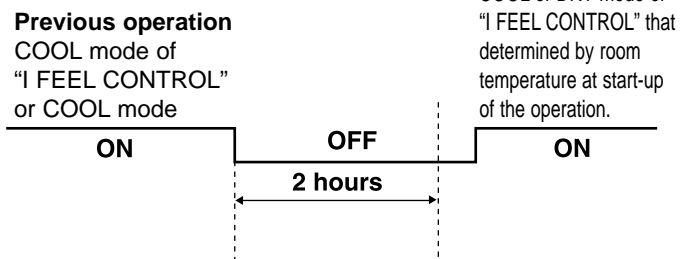
##### Example



When the system is restarted after 2 hours and more, the operation mode is determined by the room temperature at start-up of the operation.

#### Operation timer chart

##### Example

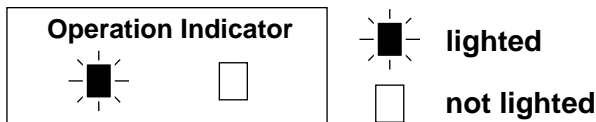


### INDOOR UNIT DISPLAY SECTION

#### Operation Indicator lamp

The operation indicator at the right side of the indoor unit indicates the operation state.

- The following indication applies regardless of shape of the indicator.



Indication	Operation state	Difference between set temperature and room temperature
	This shows that the air conditioner is operating to reach the target temperature. Please wait until the target temperature is obtained.	Approx. 4°F or more
	This shows that the room temperature is approaching the target temperature.	Approx. 4°F or less

(4) The initial set temperature is decided by the initial room temperature.

Mode	Initial room temperature	Initial set temperature	
COOL mode of "I FEEL CONTROL"	79°F or more	75°F	※1
	77°F to 79°F	Initial room temperature minus 4°F	
DRY mode of "I FEEL CONTROL"	more than 55°F, less than 77°F	Initial room temperature minus 4°F	

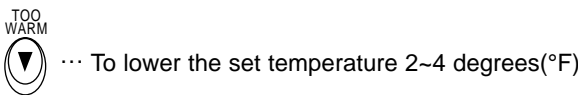
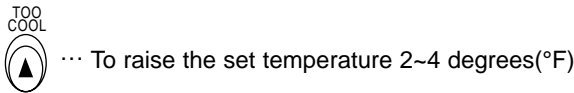
※ 1 When the system is restarted with the remote controller, the system operates with the previous set temperature regardless of the room temperature at restart.  
The set temperature is calculated by the previous set temperature.

(5) TEMPERATURE buttons

In "I FEEL CONTROL" (□) mode, set temperature is decided by the microprocessor based on the room temperature. In addition, set temperature can be controlled by TOO WARM or TOO COOL buttons when you feel too cool or too warm. Each time the TOO WARM or TOO COOL button is pressed the indoor unit receives the signal and emits a beep tone.

● Fuzzy control

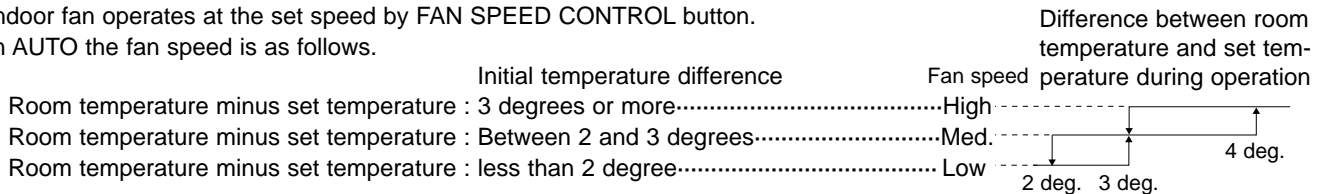
When the TOO COOL or TOO WARM button is pressed the microprocessor changes the set temperature, considering the room temperature, the frequency of pressing TOO COOL or TOO WARM button and the user's preference to heat or cool. So this is called "Fuzzy control", and works only in "I FEEL CONTROL" mode. In DRY mode of "I FEEL CONTROL", the set temperature doesn't change.



8-1-1. COOL mode of "I FEEL CONTROL"

1. Indoor fan speed control

Indoor fan operates at the set speed by FAN SPEED CONTROL button. In AUTO the fan speed is as follows.



2. Coil frost prevention

① Temperature control

When the indoor coil thermistor RT12 or RT13 reads 30°F or below, the coil frost prevention mode starts immediately. However the coil frost prevention doesn't work for 5 minutes since the compressor has started. The indoor fan operates at the set speed and the compressor stops for 5 minutes. After that, if RT12 or RT13 still reads below 30°F this mode prolonged until the RT12 and RT13 reads over 30°F.

② Time control

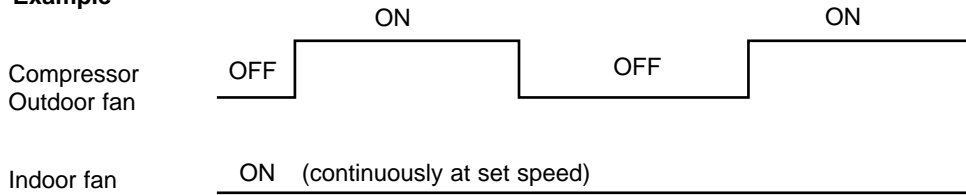
When the three conditions as follows have been satisfied for 1 hour and 45 minutes, compressor stops for 3 minutes.

- a. Compressor has been continuously operating.
- b. Indoor fan speed is Low or Med.
- c. Room temperature is below 79°F.

When compressor stops, the accumulated time is cancelled and when compressor restarts, time counting starts from the beginning.

Time counting also stops temporarily when the indoor fan speed becomes High or the room temperature exceeds 79°F. However, when two of the above conditions (b.and c.) are satisfied again. Time accumulation is resumed.

**Operation chart**  
**Example**



**3. Discharge temperature protection**

The compressor is controlled by the temperature of discharge temperature thermistor RT62 for excess rise protection of compressor discharge pressure.

• Compressor

When the temperature of discharge temperature thermistor RT62 goes to 248°F or more, the compressor is turned OFF. After 3 minutes since the compressor has been turned OFF, if the temperature of discharge temperature thermistor RT62 becomes 212°F or less, the compressor is turned ON.

**8-1-2. DRY mode of “I FEEL CONTROL”**

The system for dry operation uses the same refrigerant circuit as the cooling circuit.

The compressor and the indoor fan are controlled by the room temperature.

By such controls, indoor flow amounts will be reduced in order to lower humidity without much room temperature decrease.

**1. Indoor fan speed control**

Indoor fan operates at the set speed by FAN SPEED CONTROL button.

However, in AUTO fan operation, fan speed becomes Low.

**2. The operation of the compressor and indoor / outdoor fan**

Compressor operates by room temperature control and time control.

Set temperature is controlled to fall 4°F from initial room temperature.

Indoor fan and outdoor fan operate in the same cycle as the compressor.

• When the room temperature is 73°F or over:

When the thermostat is ON, the compressor repeats 8 minutes ON and 3 minutes OFF.

When the thermostat is OFF, the compressor repeats 4 minutes OFF and 1 minute ON.

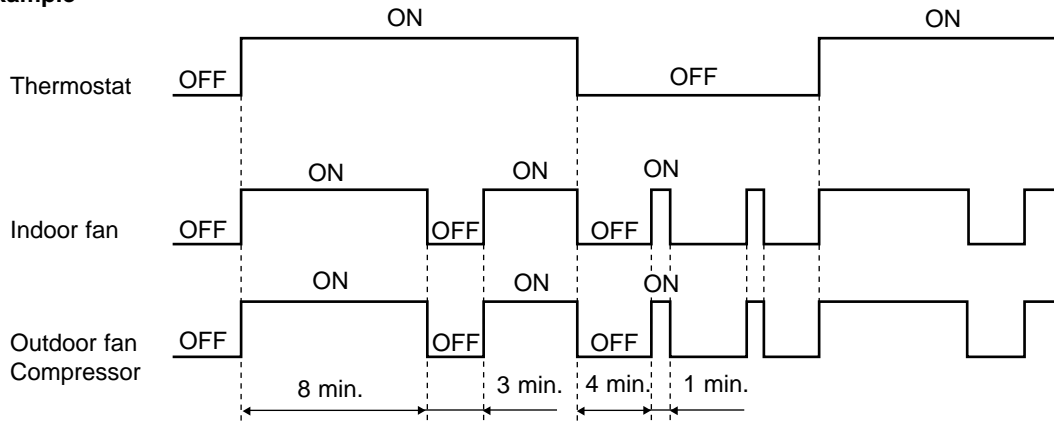
• When the room temperature is under 73°F.

When the thermostat is ON, the compressor repeats 2 minutes ON and 3 minutes OFF.

When the thermostat is OFF, the compressor repeats 4 minutes OFF and 1 minute ON.

**Operation time chart**

**Example**



**3. Coil frost prevention**

The operation is as same as coil frost prevention during COOL mode of “I FEEL CONTROL”.

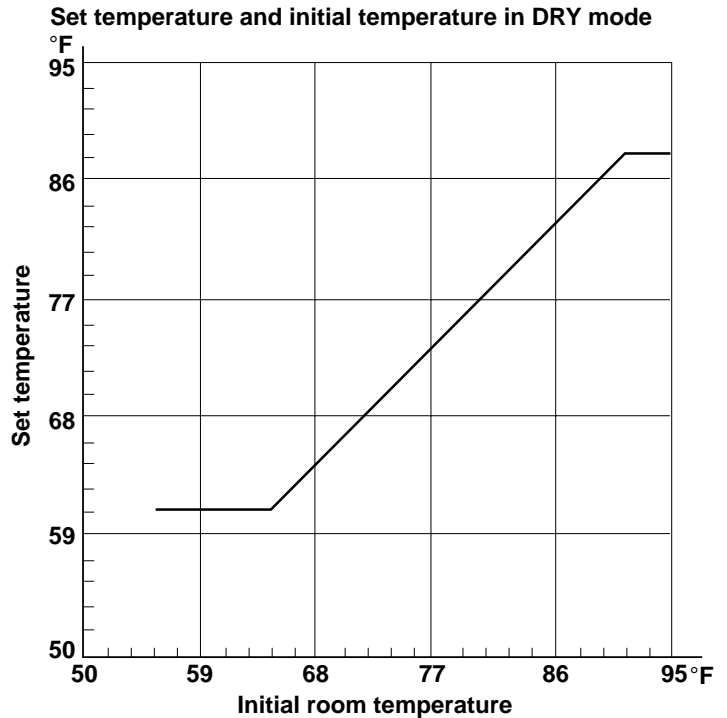
Indoor fan operates at the set speed and the compressor stops for 5minutes, because protection (Coil frost prevention) has the priority. However when coil frost prevention works while the compressor is not operating, it's speed becomes Low.

## 8-2. COOL ( ❄ ) OPERATION

- (1) Press OPERATE/STOP(ON/OFF) button.  
OPERATION INDICATOR lamp of the indoor unit turns on with a beep tone.
- (2) Select COOL mode with the OPERATION SELECT button.
- (3) Press TEMPERATURE buttons.  
(TOO WARM or TOO COOL button) to select the desired temperature.  
The setting range is 59 ~ 89°F.  
\* Indoor fan continues to operate regardless of thermostat's OFF-ON at set speed.  
\* Coil frost prevention is as same as COOL mode of "I FEEL CONTROL".

## 8-3. DRY ( △ ) OPERATION

- (1) Press OPERATE/STOP(ON/OFF) button.  
OPERATION INDICATOR lamp of the indoor unit turns on with a beep tone.
- (2) Select DRY mode with the OPERATION SELECT button.
- (3) The microprocessor reads the room temperature and determines the set temperature. Set temperature is as shown on the right chart.  
Thermostat (SET TEMP.) does not work.  
The other operations are same as DRY mode of "I FEEL CONTROL".
- (4) DRY operation will not function when the room temperature is 55°F or below.

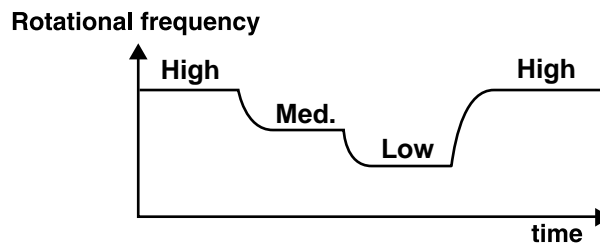


## 8-4. FAN( ⚙ ) OPERATION

- (1) Press OPERATE/STOP(ON/OFF) button.  
OPERATION INDICATOR lamp of the indoor unit turns ON with a beep tone.
- (2) Select FAN mode with the OPERATION SELECT button.  
Only indoor fan operates. Outdoor unit does not operate.

## 8-5. FAN MOTOR CONTROL

- (1) Rotational frequency feedback control  
The indoor fan motor is equipped with a rotational frequency sensor, and outputs signal to the microprocessor to feedback the rotational frequency. Comparing the current rotational frequency with the target rotational frequency (High, Med., Low), the microprocessor controls, SR141 and adjusts fan motor electric current to make the current rotational frequency close to the target rotational frequency. With this control, when the fan speed is switched, the rotational frequency changes smoothly.



- (2) Fan motor lock-up protection  
When the rotational frequency feedback signal has not output for 12 seconds, (or when the microprocessor cannot detect the signal for 12 seconds) the fan motor is regarded locked-up. Then the electric current to the fan motor is shut off. 3 minutes later, the electric current is applied to the fan motor again. During the fan motor lock-up, the OPERATION INDICATOR lamp flashes on and off to show the fan motor abnormality. (Refer to page 29.)

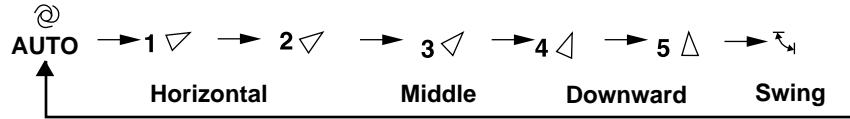
## 8-6. AUTO VANE OPERATION

### 1. Horizontal vane

#### (1) Vane motor drive

This model is equipped with a stepping motor for the horizontal vane. The rotating direction, speed, and angle of the motor are controlled by pulse signals (approx. 12V) transmitted from microprocessor.

#### (2) The horizontal vane angle and mode change as follows by pressing the VANE button.



#### (3) Positioning

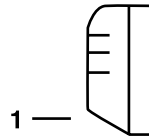
The vane is once pressed to the vane stopper below to confirm the standard position and then set to the desired angle. Confirming of standard position is performed in case of follows.

- When the OPERATE/STOP(ON/OFF) button is pressed(POWER ON/OFF).
- When the vane control is changed from AUTO to MANUAL.
- When the SWING is finished.
- When the test run starts.
- When the power supply turns ON.

#### (4) VANE AUTO ( @ ) mode

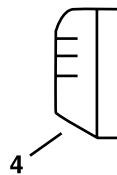
In VANE AUTO mode, the microprocessor automatically determines the horizontal vane angle and operation to make the optimum room-temperature distribution.

##### ① In COOL and DRY operation



Vane angle is fixed to Angle 1.

##### ② In FAN operation



Vane angle is fixed to Angle 4.

#### (5) STOP (operation OFF) and ON-TIMER standby.

When the following cases occur, the horizontal vane returns to the closed position.

- When the OPERATE/STOP(ON/OFF) button is pressed (POWER OFF).
- When the operation is stopped by the emergency operation.
- When the ON-TIMER is on standby.

#### (6) Dew prevention


During COOL or DRY operation at Vane Angle 4 or 5 when the compressor cumulative operation time exceeds 1 hour, the vane angle automatically changes to Angle 1 for dew prevention.

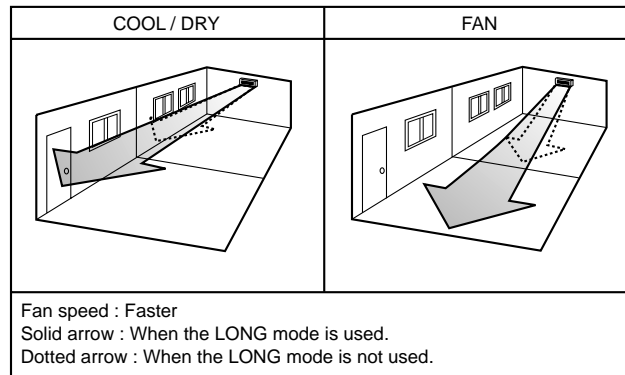
#### (7) SWING MODE ( ㄣ )

By selecting SWING mode with the VANE button, the horizontal vane swings vertically. The remote controller displays “ ㄣ ”.

#### (8) LONG MODE ( ㄣ )

By pressing the LONG button indoor fan speed becomes faster than setting fan speed on the remote controller, and the horizontal vane moves to the position for LONG mode. The remote controller displays “ ㄣ ”. LONG mode is cancelled when the LONG button is pressed once again or the VANE button is pressed.

- In the following example, the vertical vane is set to  (front.).

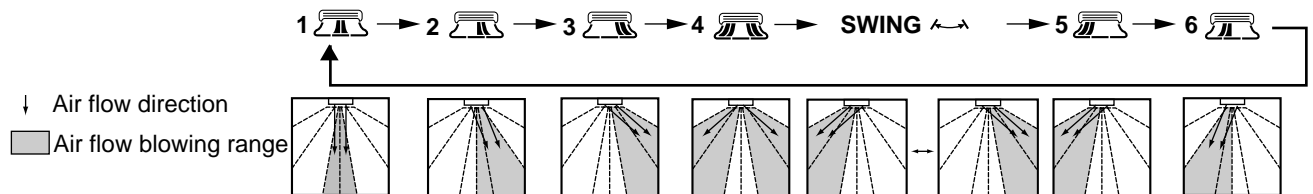


## 2. Vertical vane

### (1) Vane motor drive

This model is equipped with a stepping motor for the vertical vane. The rotating direction, speed, and angle of the motor are controlled by pulse signals (approx. 12V) transmitted from indoor microprocessor.

### (2) The vertical vane angle and mode changes as follows by pressing the WIDE VANE button.



### (3) Positioning

The vane is once pressed to the vane stopper to confirm the standard position and then set to the desired angle.

Confirming of standard position is performed under following conditions.

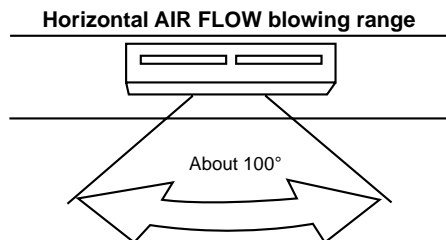
- When the OPERATE/STOP(ON/OFF) button is pressed (POWER ON/OFF).
- When the SWING is started or finished.
- When the power supply turns ON.



### (4) SWING MODE (↔)

By selecting SWING mode with the WIDE VANE button, the vertical vane swings horizontally. The remote controller displays "↔". The vane moves right and left in the width of Angle 4 repeatedly.

### (5) WIDE MODE (🌀)

By selecting WIDE mode with the WIDE VANE button, indoor fan speed becomes faster than setting fan speed on the remote controller(\*). The remote controller displays "🌀".



\* Indoor fan speed becomes faster than setting fan speed on the remote controller even when  or  is selected.

## 8-7. TIMER OPERATION

### 1. How to set the timer

- Press OPERATE/STOP(ON/OFF) button to start the air conditioner.
- Check that the current time is set correctly.

**NOTE** : Timer operation will not work without setting the current time. Initially "AM0:00" blinks at the current time display of TIMER MONITOR, so set the current time correctly with CLOCK SET button.

### (3) Press ON/OFF TIMER buttons to select the operation.

- "ON-TIMER" button... AUTO START operation (ON timer)
- "OFF-TIMER" button... AUTO STOP operation (OFF timer)

(4) Press HR. and MIN. button (TIME set button) to set the timer. Time setting is 10-minute units.

HR. and MIN. button will work when “ $\ominus \rightarrow |$ ” or “ $\ominus \rightarrow \bigcirc$ ” mark is flashing.

These marks disappear in 1 minute.

After setting the ON timer, check that OPERATION INDICATOR lamp of the indoor unit lights.

**NOTE1** :Be sure to place the remote controller at the position where its signal can reach the air conditioner even during TIMER operation, or the set time may deviate within the range of about 10 minutes.

**NOTE2** :Reset the timer in the following cases, or the set time may deviate and other malfunctions may occur.

- A power failure occurs.
- The circuit breaker functions.

## 2. Cancel

TIMER setting can be cancelled with the ON/OFF TIMER buttons.

To cancel the ON timer, press the “ON-TIMER” button.

To cancel the OFF timer, press the “OFF-TIMER” button.

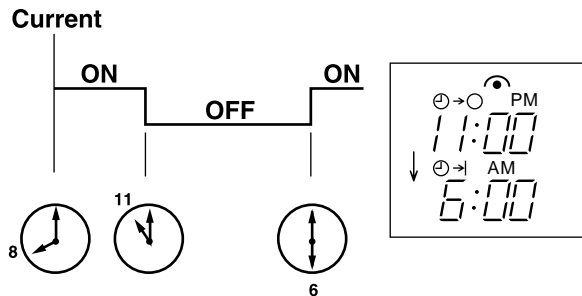
TIMER is cancelled and the display of set time disappears.

## PROGRAM TIMER

- The OFF timer and ON timer can be used in combination.
- “ $\uparrow$ ” and “ $\downarrow$ ” display shows the order of the OFF timer and ON timer operation.

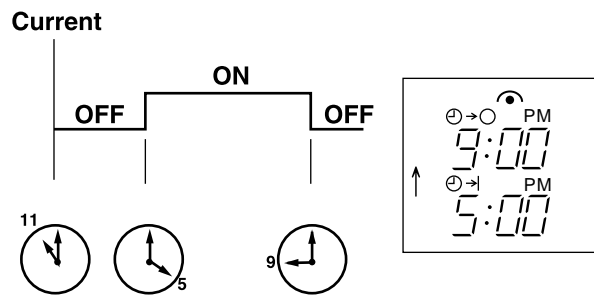
(Example 1) The current time is 8:00 PM.

The unit turns off at 11:00 PM, and on at 6:00 AM.



(Example 2) The current time is 11:00 AM.

The unit turns on at 5:00 PM, and off at 9:00 PM.



**NOTE** : TIMER setting will be cancelled by power failure or breaker functioning.

## 8-8. EMERGENCY-TEST OPERATION

In case of test run operation or emergency operation, use the EMERGENCY OPERATION switch on the front of the indoor unit. Emergency operation is available when the remote controller is missing, has failed or the batteries of remote controller run down. The unit will start and the OPERATION INDICATOR lamp will light.

The first 30 minutes of operation is the test run operation. This operation is for servicing. The indoor fan speed runs at High speed and the system is in continuous operation. (The thermostat is ON.)

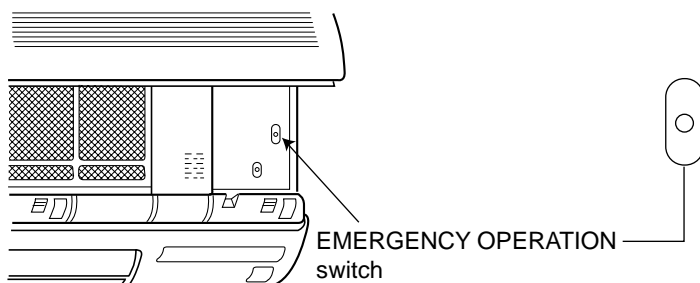
After 30 minutes of test run operation the system shifts to EMERGENCY COOL MODE with a set temperature of 75°F. The fan speed shifts to Med. speed.

The coil frost prevention works even in emergency operation.

In the test run or emergency operation, the horizontal vane operates in VANE AUTO ( @ ) mode.

Emergency operation continues until the EMERGENCY OPERATION switch is pressed again or the unit receives any signal from the remote controller. In case of latter normal operation will start.

**NOTE** : Do not press the EMERGENCY OPERATION switch during normal operation.



- The following indication applies regardless of shape of the indicator.

	OPERATION INDICATOR lamp	
Press once	<Cool>	<input type="checkbox"/>
Press once again	<Stop>	<input type="checkbox"/> <input type="checkbox"/>

## 8-9. LEV control

LEV (Expansion valve) is controlled by "Thermostat ON" commands given from the unit.

Basic specification	Controlled range	Minimum : 54 pulse, Maximum : 500 pulse
	Drive speed	30 ~ 90 pulse / second
	Opening set	The setting is always in opening direction. (To close the LEV, it is closed to the pulse smaller than the one which is set finally. Then the LEV is opened to the final setting pulse.)
General operation	Stop of indoor unit	Opening in stop : 150 pulse → LEV opening is set to becomes 500 pulse after 3 minutes passed.
	Remote controller ON	LEV positioning (LEV is closed completely at once)
	Power ON (Breaker ON)	LEV is positioned. However, afterwards, LEV is not positioned at the first remote controller ON.
	Approximate for 2 minutes since compressor has started.	Opening is set by the initial opening. (Initial opening is set according to each operation modes and outer temperature conditions.)
	From approximate 2 minutes to approximate 13 minutes (for 11 minutes) since compressor has started.	Opening is set by standard opening. (Standard opening is set according to each operation modes and outer temperature conditions.)
	After 13 minutes passed since compressor has started.	LEV opening is corrected to be once every 2 minutes so that discharge temperature becomes the target discharge temperature. (When the discharge temperature is lower than target one : LEV is corrected in closed direction, when the discharge temperature is higher than target one : LEV is corrected in opening direction.)
	At thermostat OFF	Opening in stop : 150 pulse → LEV is set to the initial opening after about 3 minutes passed.
	At thermostat ON	Same as the starting of compressor operation
	At remote controller OFF	Opening in stop : 150 pulse → LEV is set so that the opening is opened completely at the speed of 4 pulse every 5 seconds in opening after about 3 minutes passed.

### (1) LEV opening correction by discharge temperature

The LEV opening is corrected according to the temperature difference between target discharge temperature ( $T_b$ ) and actual discharge temperature ( $T_a$ ).

① The LEV correction is used properly for two kinds according to the LEV opening status at operation off.

Rank	Opening immediately before having stopped last time	
	100 pulse or less (Pulse)	100 pulse or more (Pulse)
$T_a$ (F°)	Cooling	Cooling
more than $T_b+18$	5	20
$T_b+9$ to $T_b+18$	2	10
$T_b+4$ to $T_b+9$	1	2
$T_b-4$ to $T_b+4$	0	0
$T_b-9$ to $T_b-4$	-1	-2
$T_b-18$ to $T_b-9$	-2	-5
less than $T_b-18$	-5	-10

**NOTE** : Discharge temperature :  $T_a$ , Target discharge temperature :  $T_b$

② When the temperature difference  $\Delta RT$  between indoor coil thermistor (main) RT12 and indoor coil thermistor (sub) RT13 in the indoor unit is 4deg. or more for a fixed time at cool or dry operation, the target discharge temperature is changed. After the temperature is changed, when temperature difference  $\Delta RT$  is 6deg. or more, the target temperature is changed again. The LEV opening is controlled based on the changed target discharge temperature and the temperature difference  $\Delta RT$ .

Ta (F°)	$\Delta RT$		
	less than 4deg. (Pulse)	4deg. or more and less than 6deg. (Pulse)	6deg. or more (Pulse)
more than Tb+18	20	60	60
Tb+9 to Tb+18	10	20	20
Tb+4 to Tb+9	2	10	10
Tb-4 to Tb+4	0	0	0
Tb-9 to Tb-4	-2	-2	-2
Tb-18 to Tb-9	-5	-5	-5
less than Tb-18	-10	-10	-10

**NOTE** : Discharge temperature : Ta, Target discharge temperature : Tb

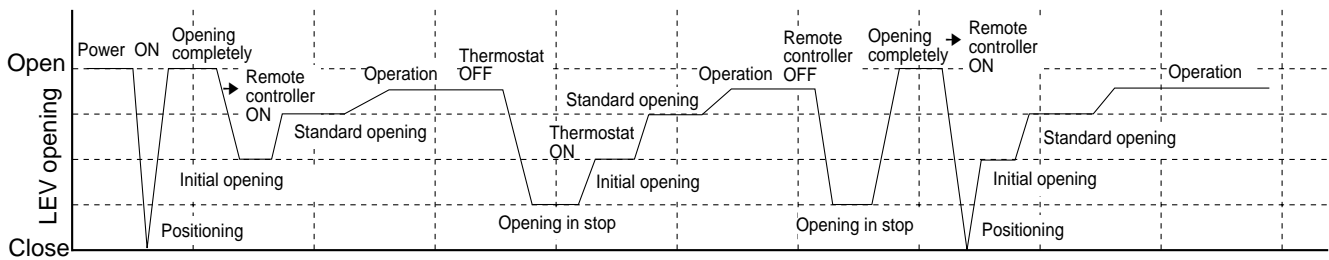
The target discharge temperature (Tb) is set according to the operation mode or the unit status as follows.

Operation mode	Tb (°F)
COOL (Normal)	171
COOL ( $\Delta RT$ is less than 4deg., or $\Delta RT$ is 4deg. or more and less than 6deg..)	144
COOL ( $\Delta RT$ is 6deg or more.)	136

**NOTE** : Target discharge temperature : Tb

**NOTE** : When the discharge temperature (Ta) is 122°F or less on the cool operation LEV opening is set in 54 pulse.  
 When this state continues for 20 minutes, the compressor is stopped and restarts in 3 minutes.  
 When the compressor is stopped, the indoor unit indicates the abnormality of refrigerant system and stops.  
 (OPERATION INDICATOR lamp is 10-time flashing on and off.)

(2) LEV time chart



**NOTE** : Opening increases and decreases to be in the target discharge temperature during operation.

## MS24WN

## 9-1. TIMER SHORT MODE

For service, set time can be shortened by short circuit of JPG and JPS the electronic control P.C. board.  
The time will be shortened as follows. (Refer to page 37.)

Set time : 1 minute → 1-second

Set time : 3 minute → 3-second (It takes 3 minutes for the compressor to start operation. However, the starting time is shortened by short circuit of JPG and JPS.)

## 9-2. P.C. BOARD MODIFICATION FOR INDIVIDUAL OPERATION

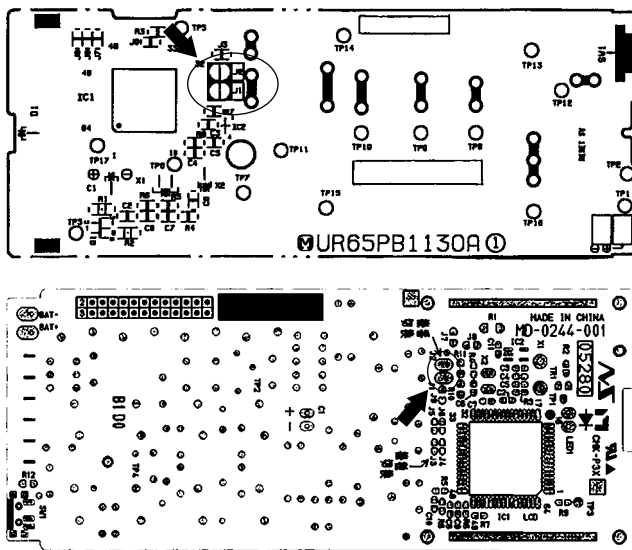
A maximum of 4 indoor units with wireless remote controllers can be used in a room.

In this case, to operate each indoor unit individually by each remote controller, P.C. boards of remote controller must be modified according to the indoor unit number.

**How to modify the remote controller P.C. board**

Remove batteries before modification.

The board has a print as shown below :



**NOTE :** For remodelling, take out the batteries and press the OPERATE/STOP(ON/OFF)button twice or 3 times at first. After finish remodelling, put back the batteries then press the RESET button.

The P.C. board has the print "J1" and "J2". Solder "J1" and "J2" according to the number of indoor unit as shown in Table 1. After modification, press the RESET button.

**Table 1**

	1 unit operation	2 units operation	3 units operation	4 units operation
No. 1 unit	No modification	Same as at left	Same as at left	Same as at left
No. 2 unit	–	Solder J1	Same as at left	Same as at left
No. 3 unit	–	–	Solder J2	Same as at left
No. 4 unit	–	–	–	Solder both J1 and J2

**How to set the remote controller exclusively for particular indoor unit**

After you turn the breaker ON, the first remote controller that sends the signal to the indoor unit will be regarded as the remote controller for the indoor unit.

The indoor unit will only accepts the signal from the remote controller that has been assigned to the indoor unit once they are set.

The setting will be cancelled if the breaker has turned off, or the power supply has shut down.

Please conduct the above setting once again after the power has restored.

### 9-3. AUTO RESTART FUNCTION

When the indoor unit is controlled with the remote controller, the operation mode, the set temperature, and the fan speed are memorized by the indoor electronic control P.C. board.

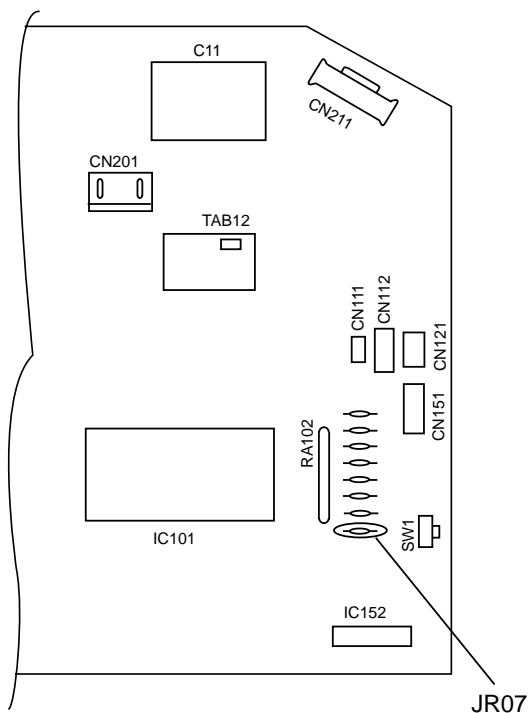
When the main power is turned off and then turned back on, the unit restarts automatically in the memorized set conditions approximately after 3 minutes.

#### How to release "AUTO RESTART FUNCTION"

- ① Turn off the main power for the unit.
- ② Pull out the indoor electronic control P.C. board and the display P.C.board. (Refer to page 40.)
- ③ Solder the Jumper wire or the Resistor 220Ω to the JR07 on the indoor electronic control P.C.board. (Refer to page 37.)

#### Operation

- ① If the main power (115V AC) has been cut, the operation settings remain.
- ② After the power is restored, the unit restarts automatically according to the memory. (However, it takes at least 3 minutes for the compressor to start running.)



#### NOTE:

- The operation settings are memorized when 10 seconds have passed after the indoor unit was operated with the remote controller.
- If the main power is turned off or a power failure occurs while AUTO START/STOP timer is active, the timer setting is cancelled.
- If the unit has been off with the remote controller before power failure, the auto restart function does not work as the power button of the remote controller is off.
- To prevent breaker off due to the rush of starting current, systematize other home appliances not to turn on at the same time.
- When some air conditioners are connected to the same power supply system, if they are operated before power failure, the starting current of all the compressors may flow simultaneously at restart. Therefore, special counter-measures are required to prevent the main voltage-drop or the rush of the starting current by adding to the system that allows the units to start one by one. (time delay)

## MS24WN MU24WN

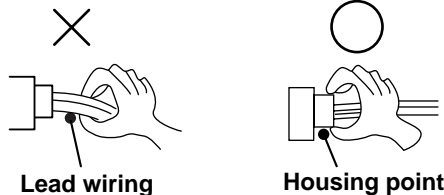
## 10-1. Cautions on troubleshooting

## 1. Before troubleshooting, check the following:

- 1) Check the power supply voltage.
- 2) Check the indoor/outdoor connecting wire for mis-wiring.

## 2. Take care the following during servicing.

- 1) Before servicing the air conditioner, first be sure to turn off the remote controller to stop the unit, and then after confirming the horizontal vane is closed, turn off the breaker and / or disconnect the power plug.
- 2) Be sure to turn OFF the power supply before removing the front panel, the cabinet, the top panel, and the electronic control P.C. board.
- 3) When removing the electronic control P.C. board, hold the edge of the board with care NOT to apply stress on the components.
- 4) When connecting or disconnecting the connectors, hold the housing of the connector. DO NOT pull the lead wires.



## 3. Troubleshooting procedure

- 1) First, check if the OPERATION INDICATOR lamp on the indoor unit is flashing on and off to indicate an abnormality. To make sure, check how many times the abnormality indication is flashing on and off before starting service work.
- 2) Before servicing check that the connector and terminal are connected properly.
- 3) If the electronic control P.C. board is supposed to be defective, check the copper foil pattern for disconnection and the components for bursting and discoloration.
- 4) When troubleshooting, refer to the flow chart on page 28 and the check table on page 29.

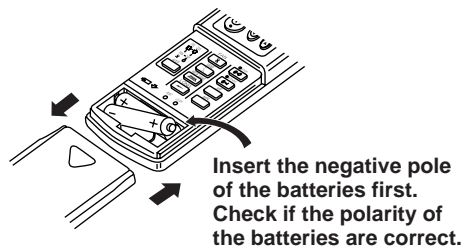
## 4. How to replace batteries

Weak batteries may cause the remote controller malfunction.

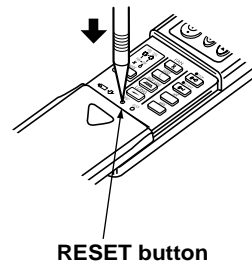
In this case, the remote controller can be repaired only by the battery replacement. To operate the remote controller normally, replace the batteries in the following order.

This remote controller has the RESET button. After refilling new batteries, press the RESET button with tip end of ball point pen or the like, and then use the remote controller.

- ① Remove the front lid and insert batteries. Then reattach the front lid.

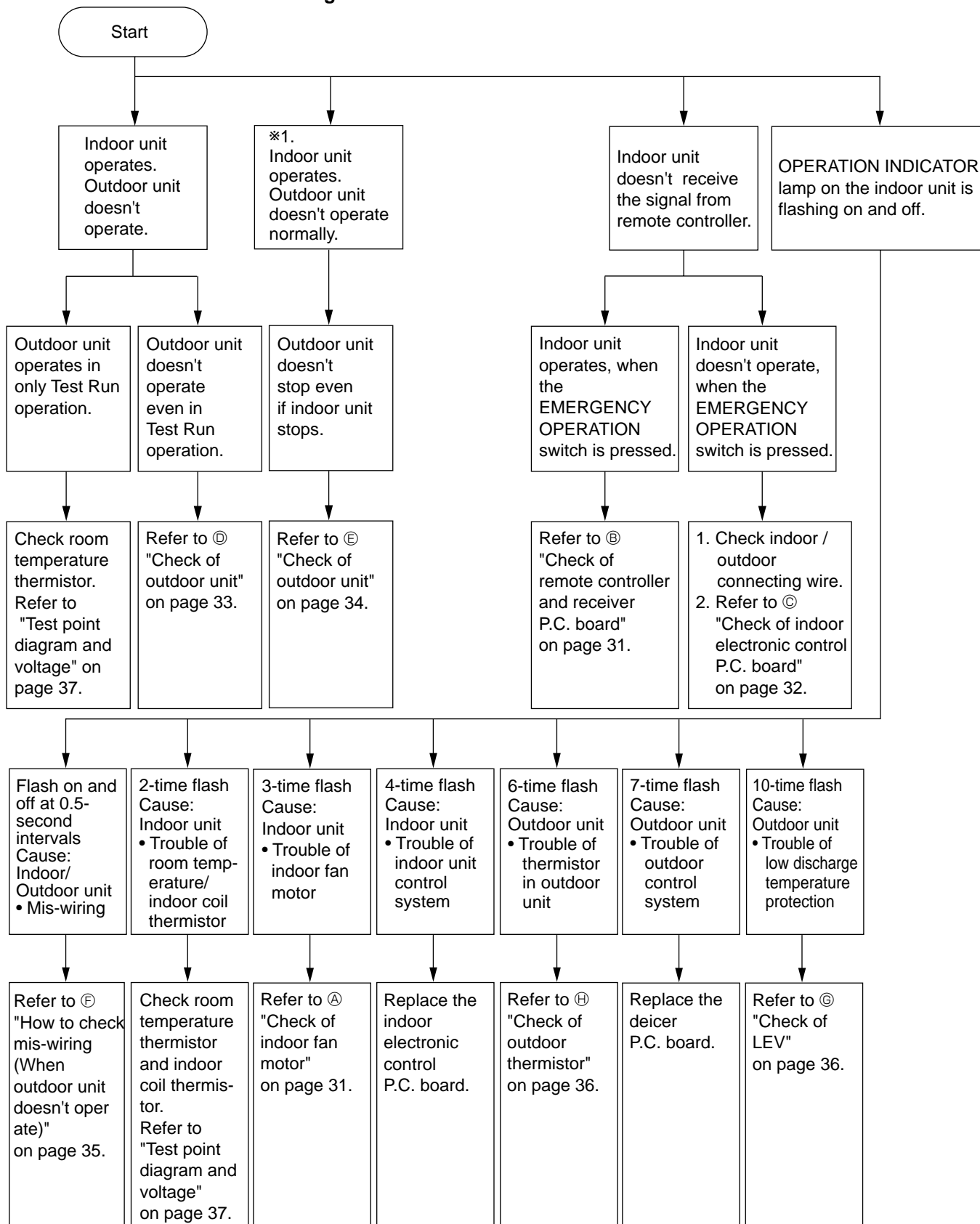


- ② Press the RESET button.



**NOTE :** If the RESET button is not pressed, the remote controller may not operate correctly.

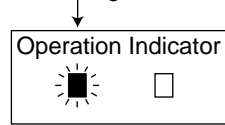
## 10-2. Instruction of troubleshooting



## 1. Troubleshooting check table

- The following indication applies regardless of shape of the indicator.


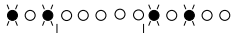
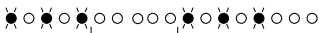
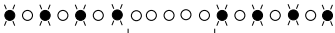
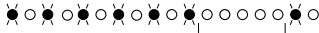

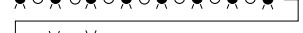
flashing



- Flashing of the OPERATION INDICATOR lamp (on the left-hand side) indicates possible abnormalities.
- The OPERATION INDICATOR lamp (on the left-hand side) is lighted during normal operation.

Before taking measures, make sure that the symptom reappears for accurate troubleshooting.

Self check table

No.	Abnormal point	Operation indicator lamp	Symptom	Detection method	Checkpoint
1	Mis-Wiring	0.5-second ON  0.5-second OFF	Outdoor unit does not operate.	3 minutes after power supply turns ON, when serial signal is not received.	<ul style="list-style-type: none"> <li>Refer to ⑥ "How to check mis-wiring" on page 35.</li> </ul>
2	Indoor coil thermistor Room temperature thermistor	2-time flash 	Outdoor unit does not operate.	Detect Indoor coil/room temperature thermistor short or open circuit every 8 seconds during operation.	<ul style="list-style-type: none"> <li>Refer to the characteristics of main indoor coil thermistor, sub indoor coil thermistor, and room temperature thermistor on page 37.</li> </ul>
3	Indoor fan motor	3-time flash 	Indoor fan repeats 12 seconds ON and 3 minutes OFF. When the indoor fan breaks, the fan keeps stopping.	When rotational frequency feedback signal is not emitting during 12-second indoor fan operation.	<ul style="list-style-type: none"> <li>Refer to ④ "Check of indoor fan motor" on page 31.</li> </ul>
4	Indoor control system	4-time flash 	Outdoor unit does not operate.	When it cannot properly read data in the nonvolatile memory of the indoor electronic control P.C. board.	<ul style="list-style-type: none"> <li>Replace the indoor electronic control P.C. board.</li> </ul>
5	Outdoor thermistors	6-time flash 	Outdoor unit does not operate.	<Thermistor short> Thermistors are abnormal when they short after compressor start-up. <Thermistor open> Thermistors are abnormal when they open after compressor start-up. However, discharge temperature thermistor is abnormal when open circuit is detected more than 10 minutes after compressor start-up.	<ul style="list-style-type: none"> <li>Replace the deicer P.C. board.</li> <li>Refer to ⑤ "Check of outdoor thermistor" on page 36.</li> <li>Reconnect the connector.</li> </ul>
6	Outdoor control system	7-time flash 	Outdoor unit does not operate.	When it cannot properly read data in the nonvolatile memory of the deicer P.C. board, outdoor unit stops.	<ul style="list-style-type: none"> <li>Replace the deicer P.C. board.</li> </ul>
7	Low discharge temperature protection	10-time flash 	Outdoor unit does not operate.	When discharge temperature has been 122°F or less on cool operation, or is 120°F or less on heat operation for 20 minutes.	<ul style="list-style-type: none"> <li>Refer to ③ "Check of LEV" on page 36.</li> <li>Check refrigerant circuit and refrigerant amount.</li> </ul>

**NOTE :** When the indoor unit has started operation and the above detection method has detected an abnormality (the first detection after the power ON), the indoor electronic control P.C. board turns OFF the indoor fan motor with the OPERATION INDICATOR lamp flashing on and off.

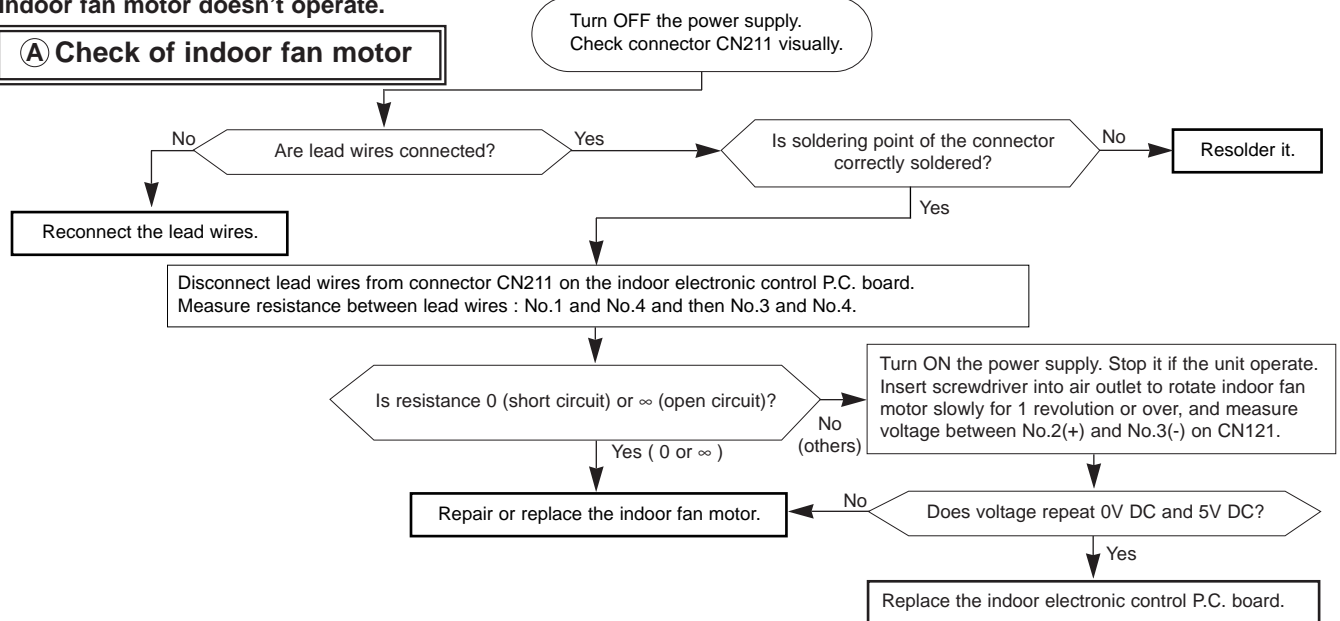
**2. Trouble criterion of main parts**  
**MS24WN MU24WN**

Part name	Check method and criterion	Figure									
Room temperature thermistor(RT11)	Measure the resistance with a tester. (Part temperature 50°F ~ 86°F)										
Indoor coil thermistor (RT12(main), RT13(sub))	<table border="1"> <tr> <td>Normal</td> <td>Abnormal</td> </tr> <tr> <td>8 kΩ ~ 20 kΩ</td> <td>Open or short-circuit</td> </tr> </table>		Normal	Abnormal	8 kΩ ~ 20 kΩ	Open or short-circuit					
Normal	Abnormal										
8 kΩ ~ 20 kΩ	Open or short-circuit										
Discharge temperature thermistor(RT62)	Measure the resistance with a tester. Before measurement, hold the thermistor with your hands to warm it up. (Part temperature 32°F ~ 104°F)										
	<table border="1"> <tr> <td>Normal</td> <td>Abnormal</td> </tr> <tr> <td>120 kΩ ~ 800kΩ</td> <td>Open or short-circuit</td> </tr> </table>		Normal	Abnormal	120 kΩ ~ 800kΩ	Open or short-circuit					
Normal	Abnormal										
120 kΩ ~ 800kΩ	Open or short-circuit										
Ambient temperature thermistor(RT63)	Measure the resistance with a tester. (Part temperature 14°F ~ 104°F)										
	<table border="1"> <tr> <td>Normal</td> <td>Abnormal</td> </tr> <tr> <td>5 kΩ ~ 60 kΩ</td> <td>Open or short-circuit</td> </tr> </table>		Normal	Abnormal	5 kΩ ~ 60 kΩ	Open or short-circuit					
Normal	Abnormal										
5 kΩ ~ 60 kΩ	Open or short-circuit										
Compressor(MC)  INNER PROTECTOR 320± 9°F OPEN 198±20°F CLOSE	Measure the resistance between the terminals with a tester. (Part temperature 14°F ~ 104°F)										
	<table border="1"> <tr> <td>Terminal</td> <td>Normal</td> <td>Abnormal</td> </tr> <tr> <td>C - R</td> <td>0.74 Ω ~ 0.91 Ω</td> <td rowspan="2">Open or short-circuit</td> </tr> <tr> <td>C - S</td> <td>1.84 Ω ~ 2.26 Ω</td> </tr> </table>		Terminal	Normal	Abnormal	C - R	0.74 Ω ~ 0.91 Ω	Open or short-circuit	C - S	1.84 Ω ~ 2.26 Ω	
Terminal	Normal	Abnormal									
C - R	0.74 Ω ~ 0.91 Ω	Open or short-circuit									
C - S	1.84 Ω ~ 2.26 Ω										
Indoor fan motor(MF)  INNER PROTECTOR 275± 9°F OPEN 187±27°F CLOSE	Motor part Measure the resistance between the terminals with a tester. (Part temperature 50°F ~ 86°F)										
	<table border="1"> <tr> <td>Color of lead wire</td> <td>Normal</td> <td>Abnormal</td> </tr> <tr> <td>WHT - BLK</td> <td>35 Ω ~ 39 Ω</td> <td rowspan="2">Open or short-circuit</td> </tr> <tr> <td>BLK - RED</td> <td>65 Ω ~ 71 Ω</td> </tr> </table>		Color of lead wire	Normal	Abnormal	WHT - BLK	35 Ω ~ 39 Ω	Open or short-circuit	BLK - RED	65 Ω ~ 71 Ω	
Color of lead wire	Normal	Abnormal									
WHT - BLK	35 Ω ~ 39 Ω	Open or short-circuit									
BLK - RED	65 Ω ~ 71 Ω										
	Sensor part Measure the voltage power ON.										
	<table border="1"> <tr> <td>Color of lead wire</td> <td>Normal</td> <td>Abnormal</td> </tr> <tr> <td>BRN - YLW</td> <td>4.5 ~ 5.5V</td> <td rowspan="2">Remain 0V or 5V</td> </tr> <tr> <td>YLW - GRY</td> <td>(When fan revolved one time) 0V→5V→0V (Approx.)</td> </tr> </table>	Color of lead wire	Normal	Abnormal	BRN - YLW	4.5 ~ 5.5V	Remain 0V or 5V	YLW - GRY	(When fan revolved one time) 0V→5V→0V (Approx.)		
Color of lead wire	Normal	Abnormal									
BRN - YLW	4.5 ~ 5.5V	Remain 0V or 5V									
YLW - GRY	(When fan revolved one time) 0V→5V→0V (Approx.)										
Outdoor fan motor(MF)  INNER PROTECTOR 293±14°F OPEN 190±27°F CLOSE	Measure the resistance between the terminals with a tester. (Part temperature 14°F ~ 104°F)										
	<table border="1"> <tr> <td>Color of lead wire</td> <td>Normal</td> <td>Abnormal</td> </tr> <tr> <td>WHT - BLK</td> <td>51 Ω ~ 62 Ω</td> <td rowspan="2">Open or short-circuit</td> </tr> <tr> <td>BLK - RED</td> <td>50 Ω ~ 61 Ω</td> </tr> </table>		Color of lead wire	Normal	Abnormal	WHT - BLK	51 Ω ~ 62 Ω	Open or short-circuit	BLK - RED	50 Ω ~ 61 Ω	
Color of lead wire	Normal	Abnormal									
WHT - BLK	51 Ω ~ 62 Ω	Open or short-circuit									
BLK - RED	50 Ω ~ 61 Ω										
Horizontal vane motor(MV1) Vertical vane motor(MV2)	Measure the resistance between the terminal with a tester. (Part temperature 50°F ~ 86°F)										
	<table border="1"> <tr> <td>Normal</td> <td>Abnormal</td> </tr> <tr> <td>282Ω ~ 306 Ω</td> <td>Open or short-circuit</td> </tr> </table>		Normal	Abnormal	282Ω ~ 306 Ω	Open or short-circuit					
Normal	Abnormal										
282Ω ~ 306 Ω	Open or short-circuit										
LEV(Expansion valve)	Measure the resistance with a tester. (Part temperature : 14°F ~ 104°F)										
	<table border="1"> <tr> <td>Color of lead wire</td> <td>Normal</td> <td>Abnormal</td> </tr> <tr> <td>WHT - RED</td> <td rowspan="4">30.3 Ω ~ 37.0 Ω</td> <td rowspan="4">Open or short-circuit</td> </tr> <tr> <td>RED - ORN</td> </tr> <tr> <td>YLW - BRN</td> </tr> <tr> <td>BRN - BLU</td> </tr> </table>		Color of lead wire	Normal	Abnormal	WHT - RED	30.3 Ω ~ 37.0 Ω	Open or short-circuit	RED - ORN	YLW - BRN	BRN - BLU
Color of lead wire	Normal		Abnormal								
WHT - RED	30.3 Ω ~ 37.0 Ω		Open or short-circuit								
RED - ORN											
YLW - BRN											
BRN - BLU											

Ⓟ:INNER PROTECTOR

When OPERATION INDICATOR lamp flashes 3-time.  
Indoor fan motor doesn't operate.

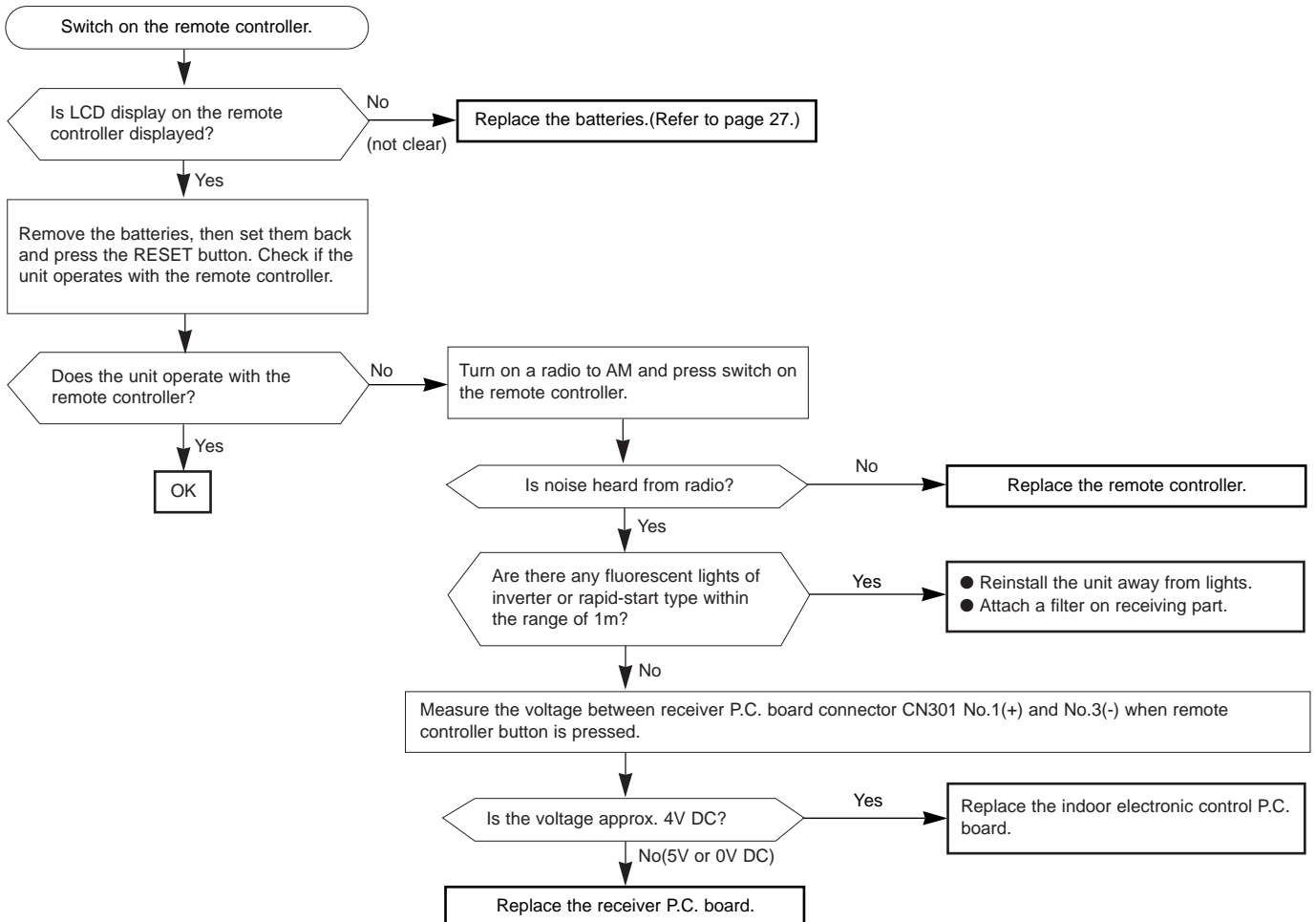
**Ⓐ Check of indoor fan motor**



Indoor unit operates by pressing the EMERGENCY OPERATION switch, but doesn't operate with the remote controller.

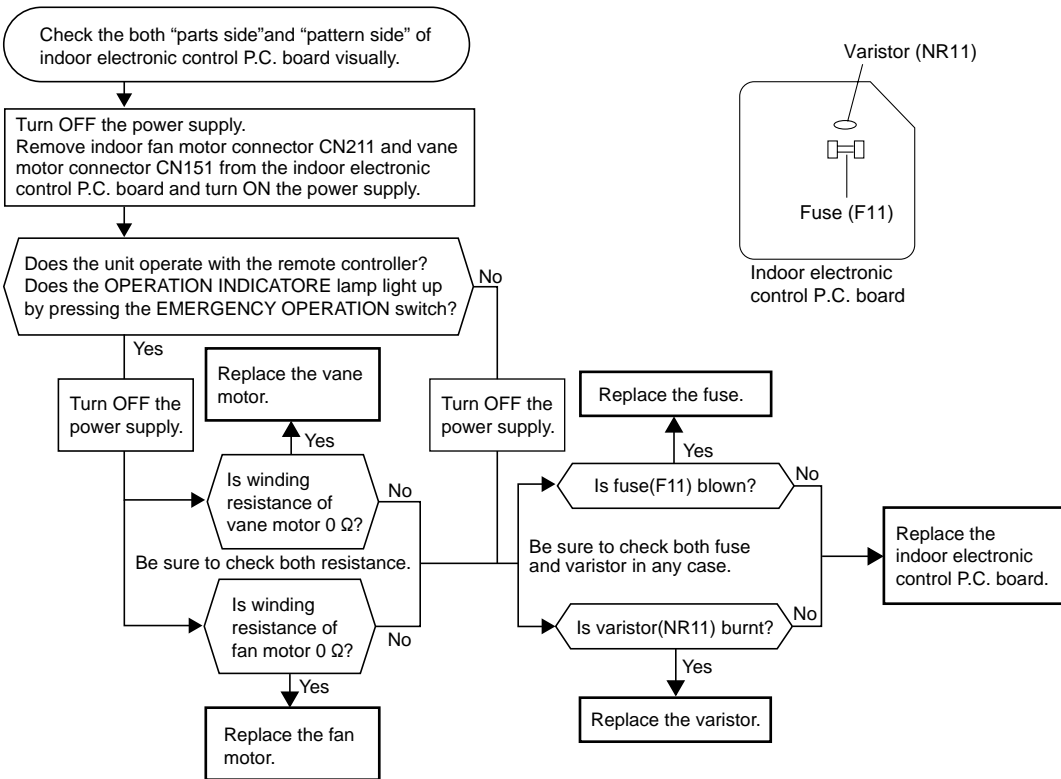
**Ⓑ Check of remote controller and receiver P.C. board**

\*Check if the remote controller is exclusive for this air conditioner.



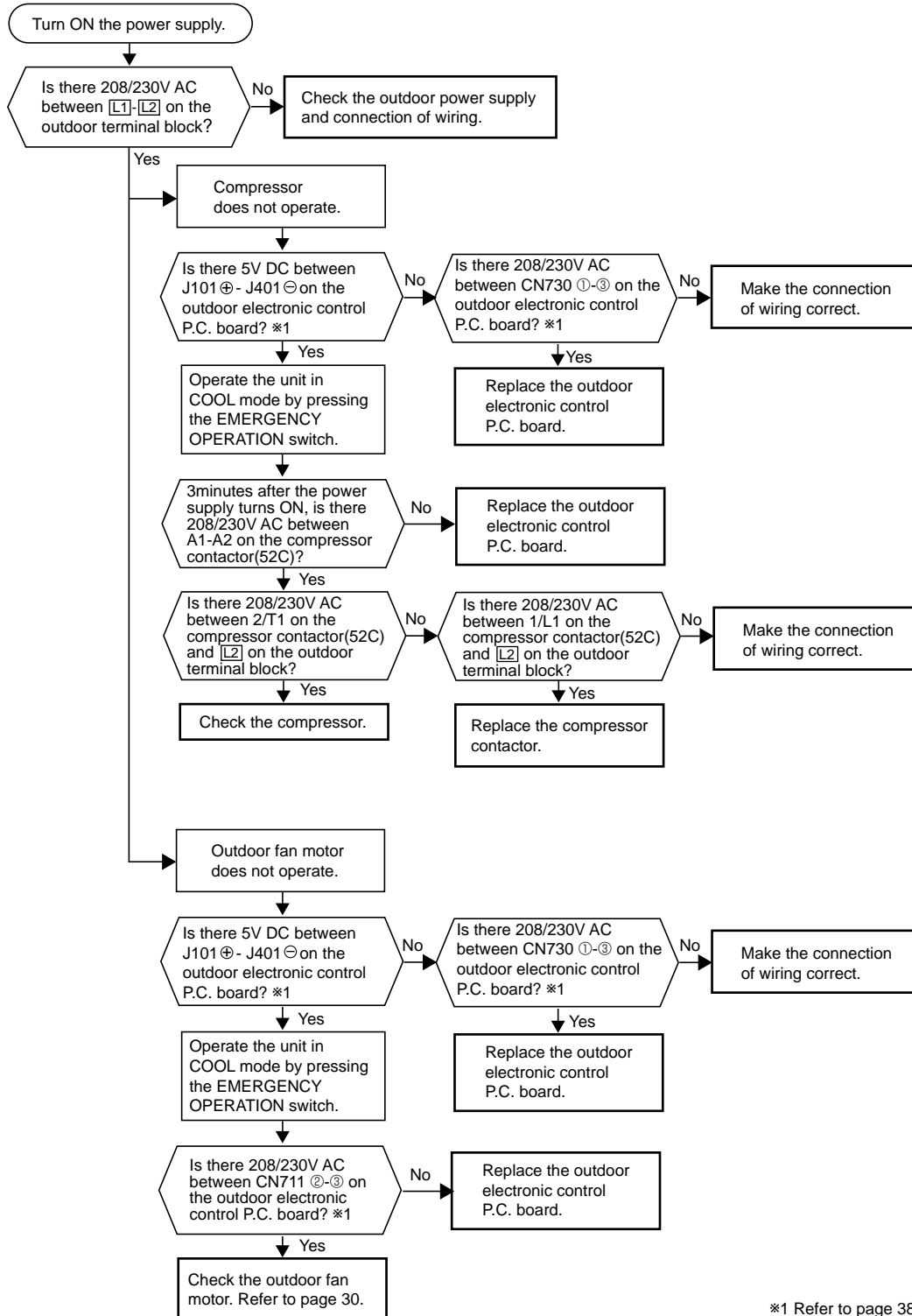
The unit doesn't operate with the remote controller.  
 Also, the OPERATION INDICATOR lamp doesn't light up by pressing the EMERGENCY OPERATION switch.

**© Check of indoor electronic control P.C. board**



## Compressor and / or outdoor fan doesn't operate.

### ④ Check of outdoor unit

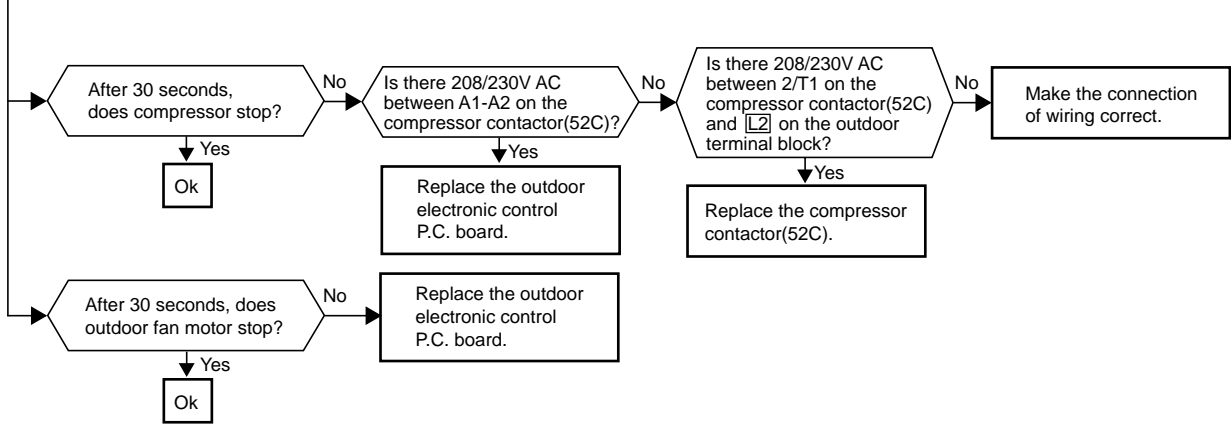


\*1 Refer to page 38.

**Compressor and / or outdoor fan motor doesn't stop.**

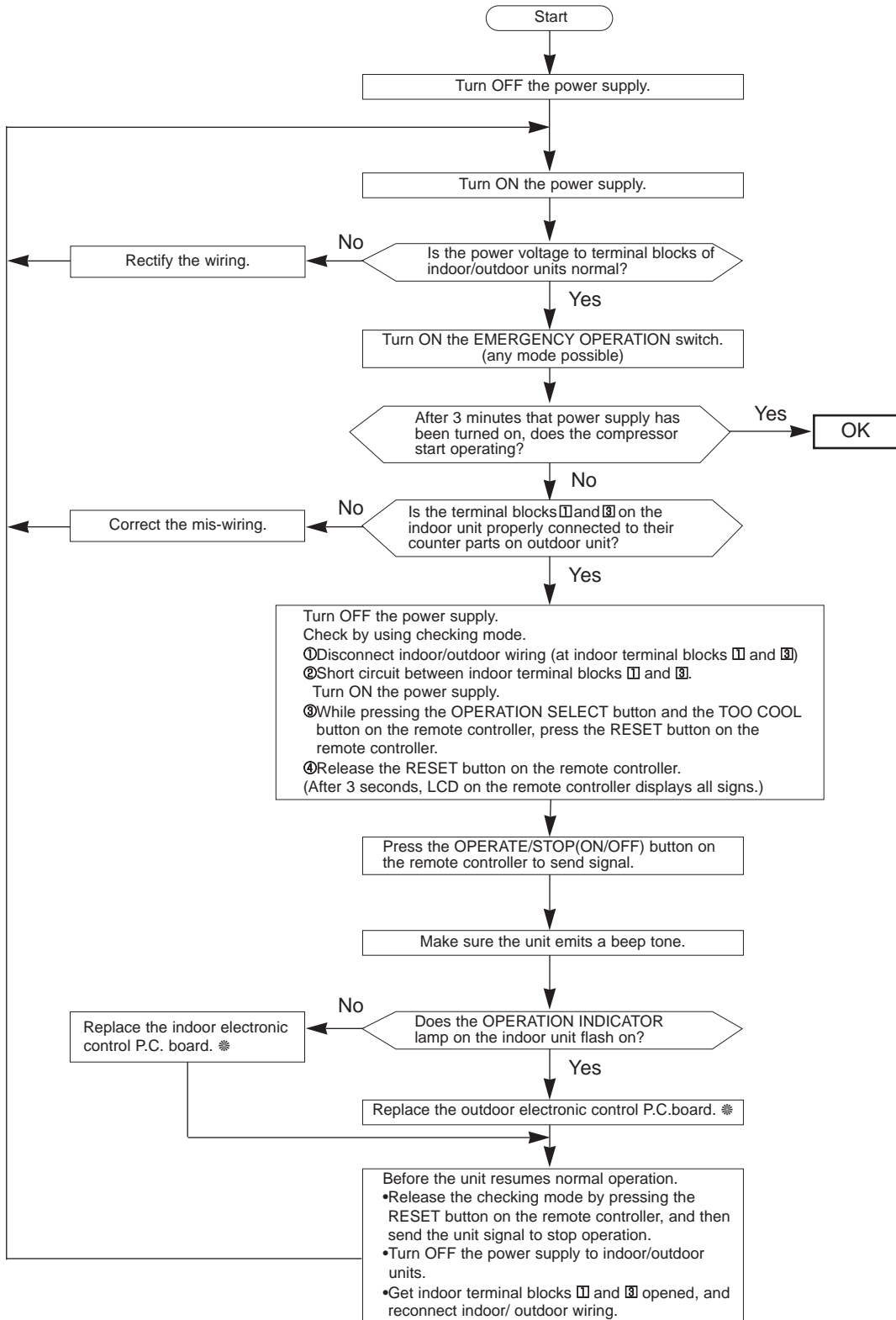
**E Check of outdoor unit**

- ① Turn OFF the power supply.
- ② After 30 seconds, turn ON the power supply again.
- ③ Operate the unit in COOL mode by pressing the EMERGENCY OPERATION switch.
- ④ Operate the unit for 1 minute or more and stop it by pressing the EMERGENCY OPERATION switch again.



When OPERATION INDICATOR lamp flashes ON and OFF in every 0.5-second.  
Outdoor unit doesn't operate.

**Ⓔ How to check mis-wiring**



[ \* Be sure to turn OFF the power supply to indoor/outdoor units in replacing P.C. board. ]

When OPERATION INDICATOR lamp flashes 10-time.  
Cooling doesn't operate.

### G Check of LEV (Expansion valve)

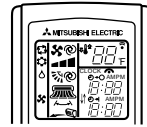
- ① During pressing the OPERATION SELECT button and the TOO COOL button on the remote controller, press the RESET button.
- ② First, release the RESET button.  
(After 3 seconds, confirm all displays of the remote controller.)
- ③ Then release the OPERATION SELECT button.



- ① During pressing the OPERATION SELECT button and the TOO COOL button on the remote controller, press RESET button.
- ② First, release the RESET button.

(After 3 seconds, confirm all displays of the remote controller.)

- ③ Then release the OPERATION SELECT button.



With remote controller set toward the indoor unit, press the OPERATE/ STOP(ON/ OFF) button and confirm one beep tone.

LEV operates in full-opening direction.

Do you hear LEV "click, click....." ?  
Do you touch LEV and feel it vibrate?

Yes → Ok

Is LEV coil properly fixed to the body?

No → Properly fix LEV coil to the body.

Does the resistance of LEV coil have the characteristics?

Yes → Replace the outdoor electronic control P.C. board.

Replace the LEV coil.

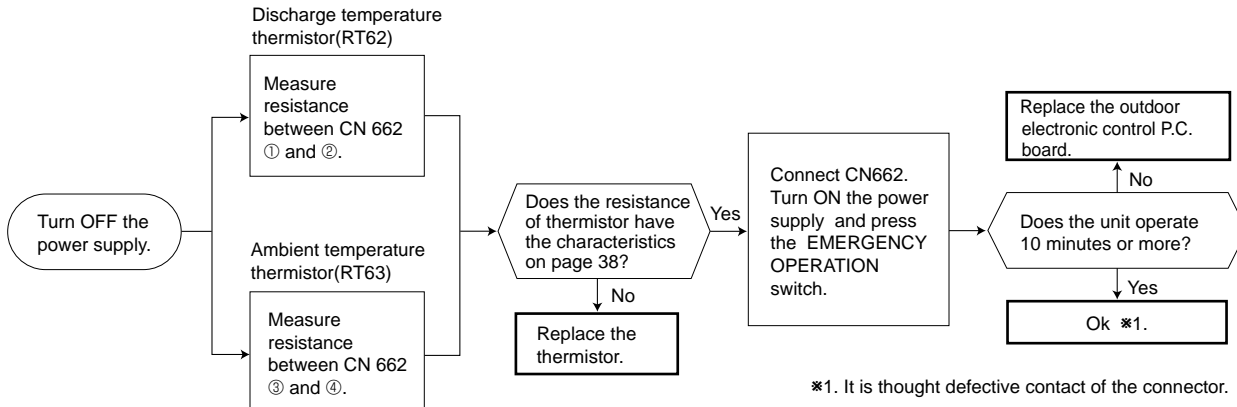
Characteristics of LEV coil	
LEV (CN724)	Resistance
WHT-RED	30.3 Ω ~ 37.0 Ω
RED-ORN	
YLW-BRN	
BRN-BLU	

**NOTE :** After check of LEV, do the undermentioned operations.  
1. Turn OFF the power supply of the unit and turn ON again.  
2. Press the RESET button on the remote controller.

When OPERATION INDICATOR lamp flashes 6-time.  
Thermistors in the outdoor unit are abnormal.

### H Check of outdoor thermistor

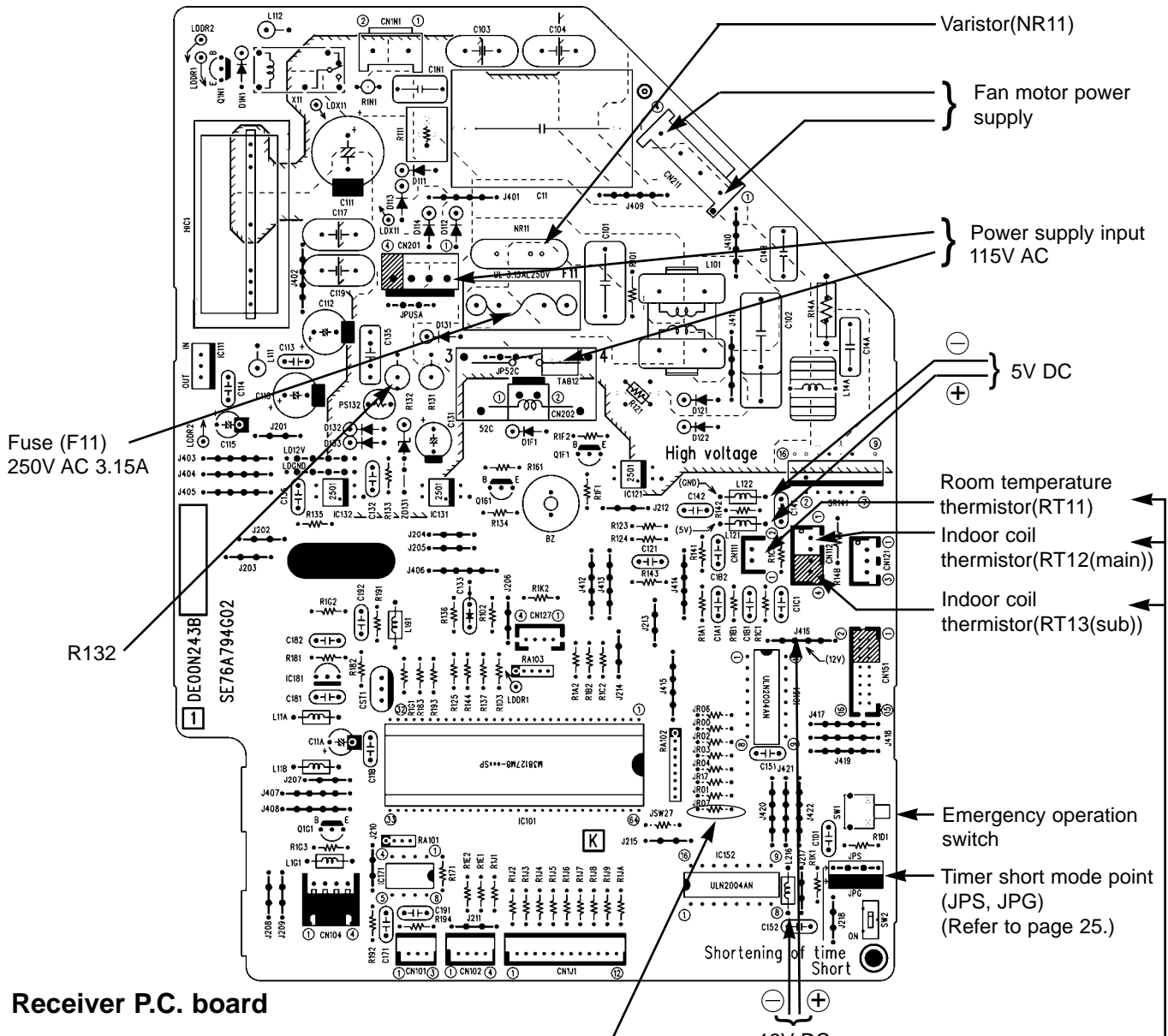
※ Disconnect the connectors CN662 from the outdoor electronic control P.C. board.  
(Check the characteristics of each thermistor.)



※1. It is thought defective contact of the connector.

# TEST POINT DIAGRAM AND VOLTAGE

## MS24WN Indoor electronic control P.C. board



Fuse (F11)  
250V AC 3.15A

R132

Varistor(NR11)  
Fan motor power supply

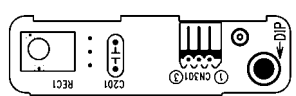
Power supply input  
115V AC

5V DC

Room temperature  
thermistor(RT11)  
Indoor coil  
thermistor(RT12(main))  
Indoor coil  
thermistor(RT13(sub))

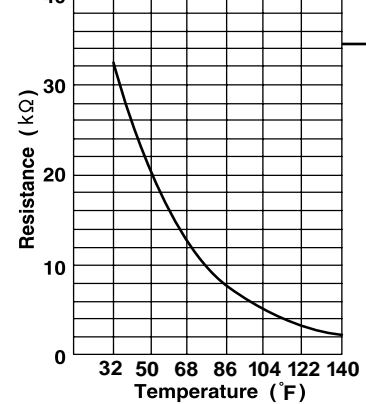
Emergency operation  
switch  
Timer short mode point  
(JPS, JPG)  
(Refer to page 25.)

### Receiver P.C. board



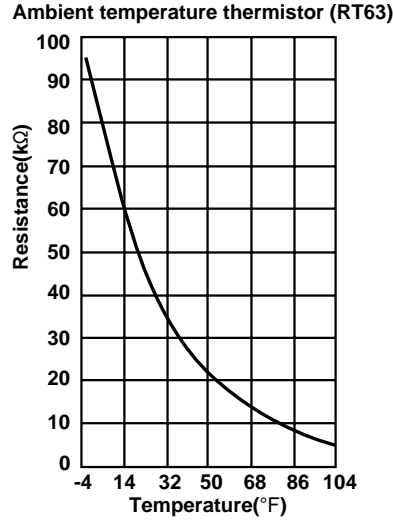
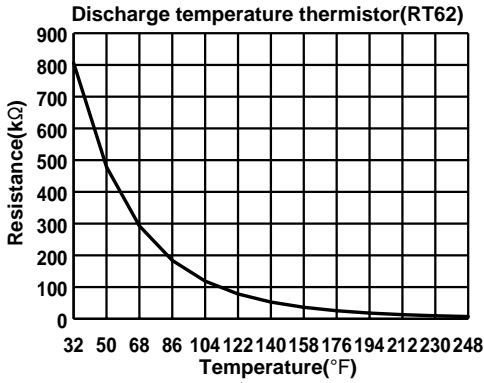
Auto restart function  
Solder the Jumper wire or the  
Resistor 220Ω to the JR07.  
(Refer to page 26.)

12V DC  
Room temperature thermistor (RT11)  
Indoor coil thermistor[RT12(main), RT13(sub)]



# MU24WN

## Outdoor electronic control P.C. board

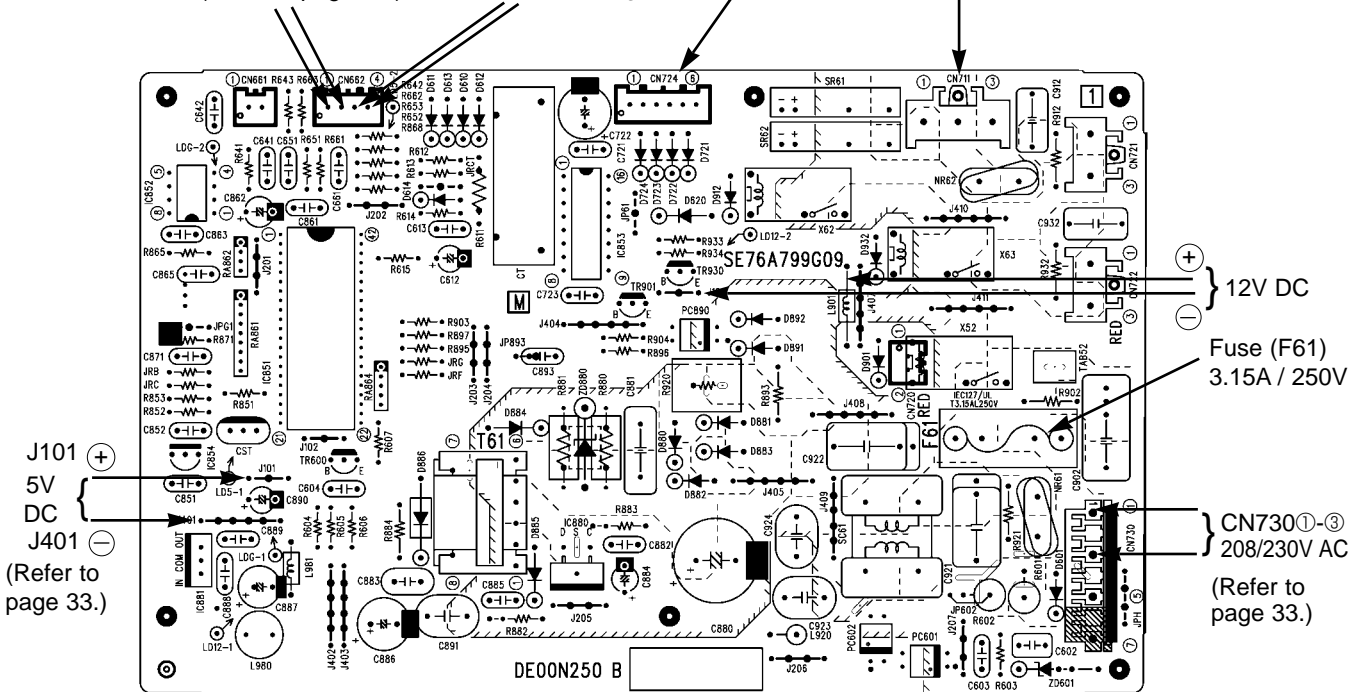


CN662 ①-②  
Discharge  
temperature  
thermistor  
(RT62)  
(Refer to page 36.)

CN662 ③-④  
Ambient  
temperature  
thermistor  
(RT63)  
(Refer to page 36.)

LEV  
connector  
(CN724)

Fan motor  
connector  
(CN711)



## RELAY OPERATION MS24WN

### COMPRESSOR CONTACTOR • EACH MODE

MODE	THERMOSTAT	52C CONTACTOR	INDOOR FAN SPEED
COOL & COOL mode of I FEEL CONTROL	ON	ON	AUTO or set speed
	OFF	OFF	
DRY & DRY mode of I FEEL CONTROL	ON	OFF for 2 min. after unit starts operation	AUTO or set speed
		Repeat of 8 min. ON/ 3min. OFF operation or 2 min. ON/3 min. OFF operation	AUTO or set speed links with 52C CONTACTOR
	OFF	Repeat of 4 min. OFF/ 1 min. ON operation	
FAN	OFF	OFF	AUTO or set speed

NOTE : Once the compressor is OFF, "3-minute time delay circuit" works at next start-up.

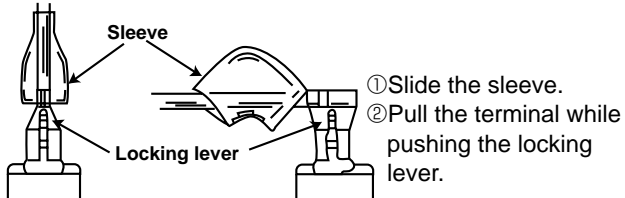
### • COIL FROST PREVENTION

MODE	THERMOSTAT	52C CONTACTOR	INDOOR FAN SPEED
COOL & COOL mode of I FEEL CONTROL	ON	OFF for 5 min. After that, OFF is prolonged until indoor coil thermistor reads termination temperature.	AUTO or set speed
DRY & DRY mode of I FEEL CONTROL			AUTO or set speed

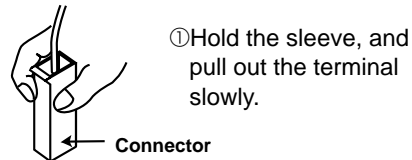
## &lt;"Terminal with lock mechanism" Detaching points&gt;

In case of terminal with lock mechanism, detach the terminal as shown below.  
There are two types ( Refer to (1) and (2) ) of the terminal with lock mechanism.  
The terminal with no lock mechanism can be removed by pulling it out.  
Check the shape of the terminal and work.

(1) Slide the sleeve and check if there is a locking lever or not.



(2) The terminal with this connector is a terminal with lock mechanism.



### 11-1. MS24WN INDOOR UNIT

OPERATING PROCEDURE	PHOTOS
<p><b>1. Removing the front panel</b></p> <p>(1) Remove the screw caps of the front panel. Remove the screws.</p> <p>(2) Pull the panel down to your side slightly and unhook the catches at the top.</p>	<p><b>Photo 1</b></p>
<p><b>2. Removing the electronic control P.C. board, the receiver P.C. board and the display P.C. board</b></p> <p><b>NOTE :</b> In case of removing only indoor electronic control P.C. board work (2) and (3) are not necessary.</p> <p>(1) Remove the front panel. (Refer to 1.)</p> <p>(2) Remove the R.L holder from the bottom of electrical box.</p> <p>(3) Open the R.L holder, remove the receiver P.C. board and the display P.C. board.</p> <p>(4) Remove the screw of the electrical cover and the electrical cover.</p> <p>(5) Pull out indoor electronic control P.C. board slightly.</p> <p>(6) Disconnect all the connectors on the electronic control P.C. board.</p> <p>(7) Remove the electronic control P.C. board.</p>	<p><b>Photo 2</b></p>

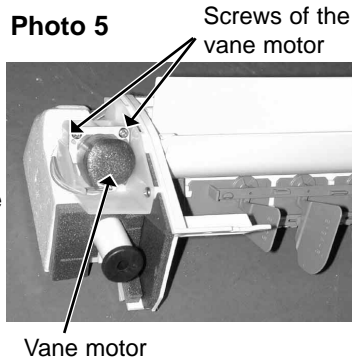
## OPERATING PROCEDURE

### 3. Removing the electrical box

- (1) Remove the front panel. (Refer to 1.)
- (2) Remove the electrical cover. (Refer to 2.)
- (3) Disconnect the connector of the indoor coil thermistor (CN112), the fan motor connector (CN211 and CN121) and the vane motor connector (CN151) on the electronic control P.C. board.
- (4) Remove the screw of ground wire.
- (5) Remove the fan motor lead wire, indoor coil thermistor and ground wire from the electrical box.
- (6) Remove the lead wire of vane motor from the bottom of electrical box.
- (7) Remove the screw of corner box and corner box. (Photo 2)
- (8) Remove the screw of conduit cover and conduit cover.
- (9) Remove the screws fixing the conduit plate.
- (10) Pull out the conduit plate and the indoor/ outdoor unit connecting wire.
- (11) Remove the lock nut from the connector of indoor/ outdoor connecting wire.
- (12) Remove the screw fixing the electrical box, remove the electrical box.

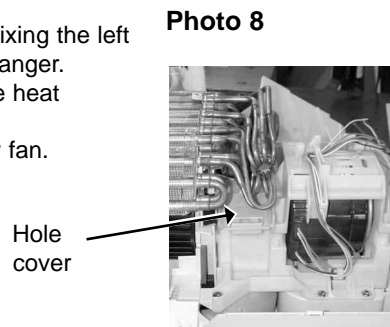
### 4. Removing the vane motor

- (1) Remove the front panel. (Refer to 1.)
- (2) Remove the electrical cover. (Refer to 2.)
- (3) Remove the lead wire of vane motor. (Refer to 3.)
- (4) Remove the R.L. holder.
- (5) Pull out the drain hose from the nozzle assembly, remove the nozzle assembly.
- (6) Remove the screws of the vane motor, disconnect the connector.
- (7) Remove the vane motor.



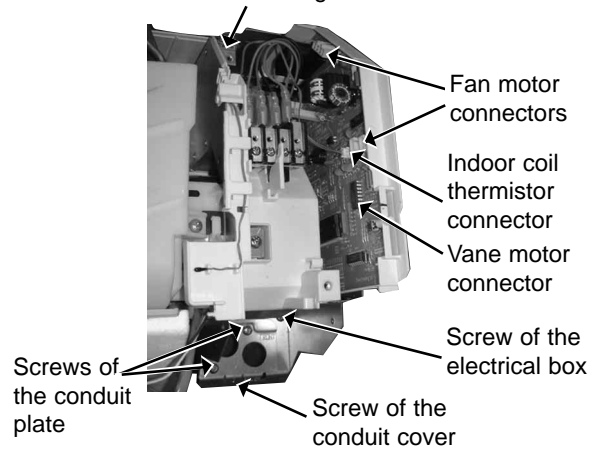
### 5. Removing the line flow fan and the indoor fan motor

- (1) Remove the front panel. (Refer to 1.)
- (2) Remove the electrical box. (Refer to 3.)
- (3) Pull out the drain hose from the nozzle assembly, remove the nozzle assembly.
- (4) Remove the water cut.
- (5) Slide the hole cover, remove the hole cover.
- (6) Remove the hexagon socket set screw from the line flow fan.
- (7) Remove the screws fixing the fan motor, remove the fan motor. (Be careful not to drop the fan motor because it is heavy.)
- (8) Remove the screws fixing the left side of the heat exchanger.
- (9) Lift the left side of the heat exchanger.
- (10) Remove the line flow fan.

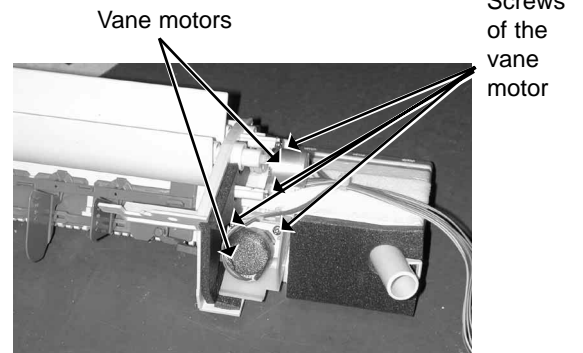


## PHOTOS

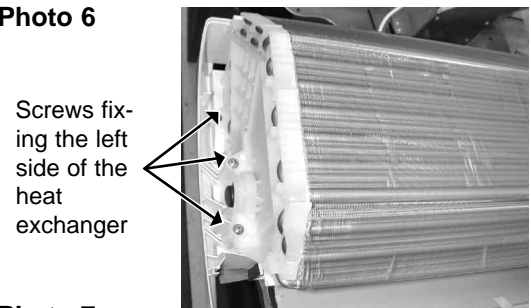
**Photo 3** Screws of the ground wire



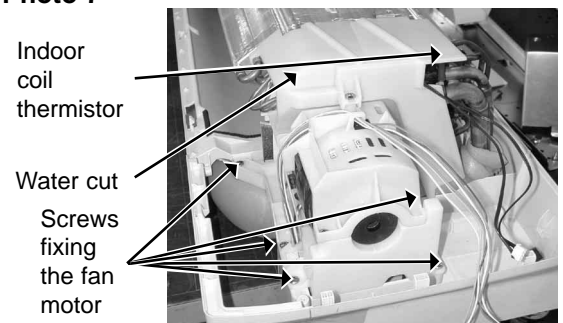
**Photo 4**



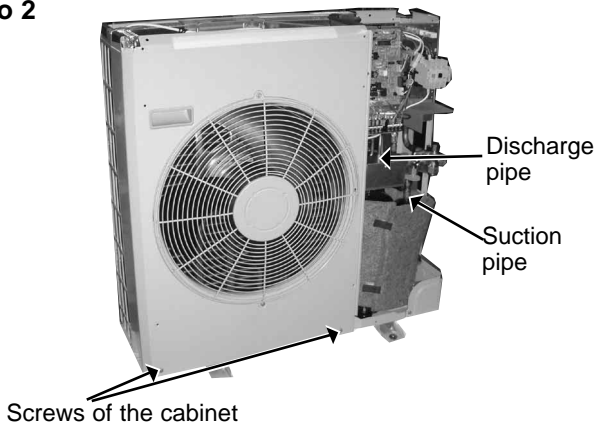
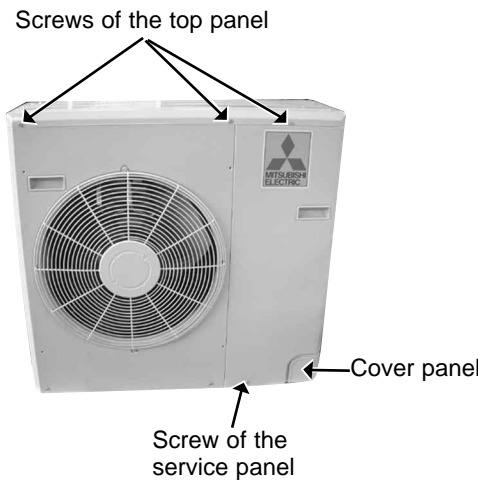
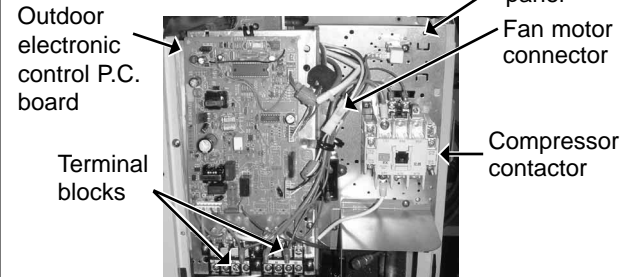
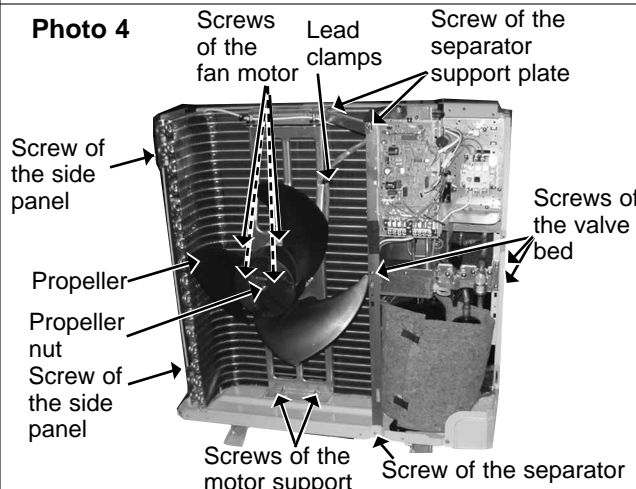
**Photo 6**



**Photo 7**



## 11-2. MU24WN OUTDOOR UNIT

OPERATING PROCEDURE	PHOTOS
<p><b>1. Removing the cabinet</b></p> <ol style="list-style-type: none"> <li>(1) Remove the screws of the top panel and the top panel.</li> <li>(2) Remove the screw of the service panel. To remove the service panel, pull it down toward you and unhook the catches on the both sides.</li> <li>(3) Remove the screw of the cover panel. To remove the cover panel.</li> <li>(4) Remove the screws of the cabinet. Open the cabinet to a 45-degree angle. Then lift it and unhook the catches to remove.</li> </ol> <p><b>Photo 2</b></p> 	<p><b>Photo 1</b></p> 
<p><b>2. Removing the outdoor electronic control P.C. board</b></p> <ol style="list-style-type: none"> <li>(1) Remove the top panel, the service panel and the cover panel.</li> <li>(2) Disconnect all the connectors and the terminals on the outdoor electronic control P.C. board.</li> <li>(3) Remove the outdoor electronic control P.C. board.</li> </ol>	<p><b>Photo 3</b></p> 
<p><b>3. Removing the propeller and the outdoor fan motor</b></p> <ol style="list-style-type: none"> <li>(1) Remove the cabinet. (Refer to 1.)</li> <li>(2) Remove the propeller nut and the propeller.</li> </ol> <p><b>NOTE:</b>Loose the propeller in the rotating direction for removal. When attaching the propeller, align the mark on the propeller and the motor shaft cut section. Set the propeller in position by using the cut on the shaft and the mark on the propeller.</p> <ol style="list-style-type: none"> <li>(3) Remove the lead clamps and disconnect the outdoor fan motor connector. (Photo 3)</li> <li>(4) Remove the screws of the outdoor fan motor and the outdoor fan motor.</li> </ol>	<p><b>Photo 4</b></p> 

## OPERATING PROCEDURE

### 4. Removing the heat exchanger and compressor

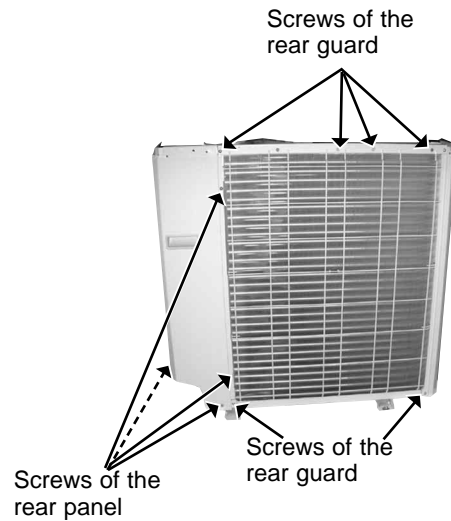
- (1) Remove the screws of the rear panel. Remove the screws of the valve bed and the valve bed.  
(The valve bed is fixed by the catches on the right and left sides. Lift it to remove.)  
Open the rear panel to the rear to remove.

**NOTE :**

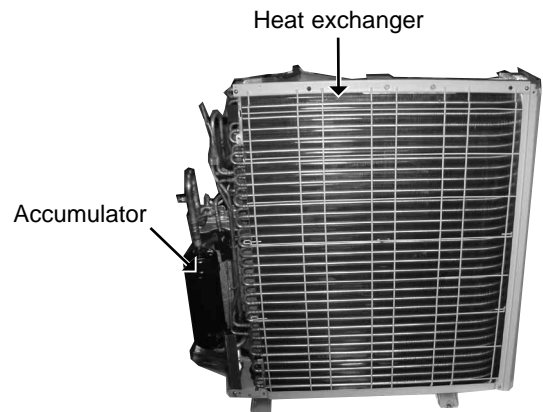
- All panels are fixed by catches, and must be removed by up and down.
- (2) Remove the screws of the side panel and the side panel. (Photo 4)
  - (3) Remove the screws of the rear guard and the rear guard.
  - (4) Remove the screws of the separator support plate and the separator support plate. (Photo 4)
  - (5) Remove the screws of the motor support and the motor support. (Photo 4)
  - (6) Remove the relay panel. (Photo 3)
  - (7) Remove the fan motor lead wire from lead clamps. (Photo 4)
  - (8) Remove the soundproof felt.
  - (9) Remove the screws of the separator and the separator.
  - (10) Recover gas from the refrigerant circuit.
  - (11) Remove the heat exchanger.  
Detach the welded part of pipe.
  - (12) Remove the nuts of the compressor and the compressor.  
Detach the welded part of the suction pipe and the discharge pipe. (Photo 2)

## PHOTOS

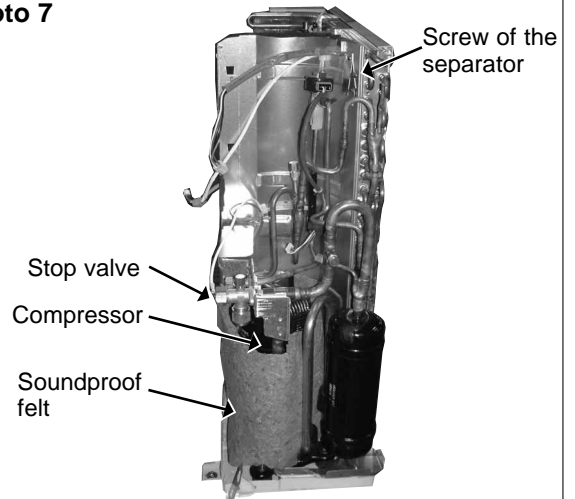
**Photo 5**



**Photo 6**

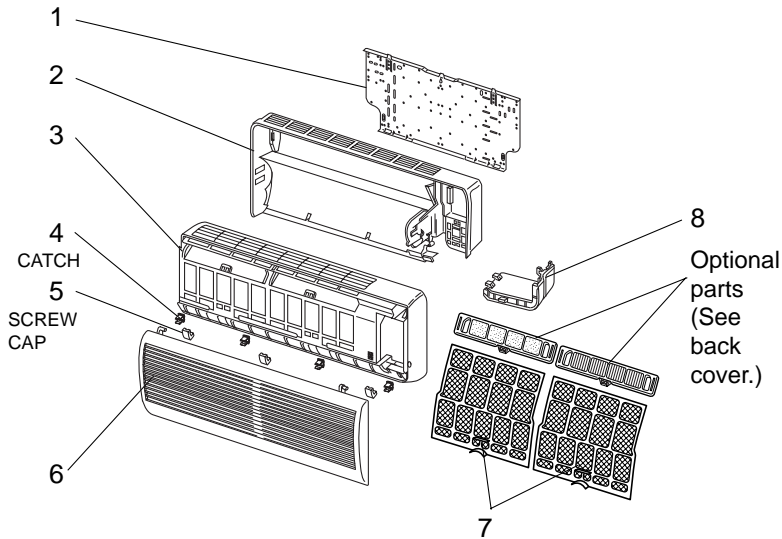


**Photo 7**

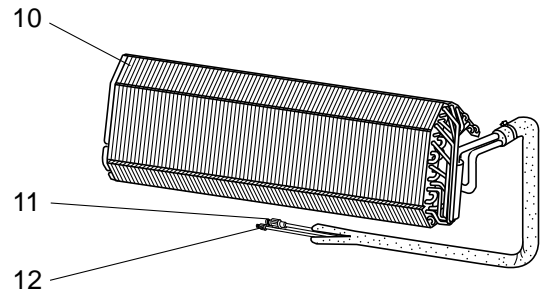


**MS24WN (W)**

**12-1. INDOOR UNIT STRUCTURAL PARTS**



**12-2. INDOOR UNIT HEAT EXCHANGER**



**12-1. INDOOR UNIT STRUCTURAL PARTS**

Part number that is circled is not shown in the illustration.

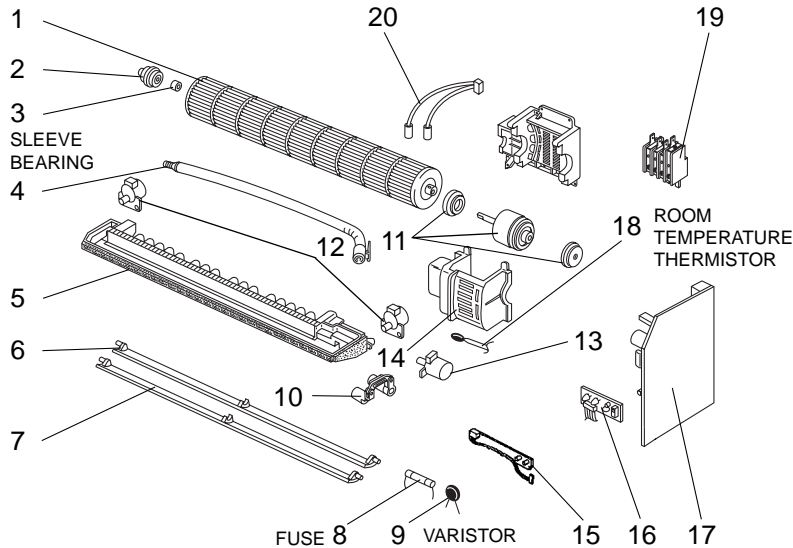
NO.	Part No.	Part Name	Symbol in Wiring Diagram	Q'ty/unit		Remarks
					MS24WN (W)	
1	E02 527 970	INSTALLATION PLATE			1	
2	E02 527 234	BOX (W)			1	
3	E02 527 000	FRONT PANEL ASSEMBLY (W)			1	Including No.4,5,6
4	E02 408 142	CATCH			4	4PCS/ SET
5	E02 527 067	SCREW CAP (W)			3	3PCS/ SET
6	E02 527 010	GRILLE (W)			1	
7	E02 527 100	AIR FILTER			2	
8	E02 527 975	CORNER BOX RIGHT			1	
⑨	E02 530 007	LAMP PANEL			1	

**12-2. INDOOR UNIT HEAT EXCHANGER**

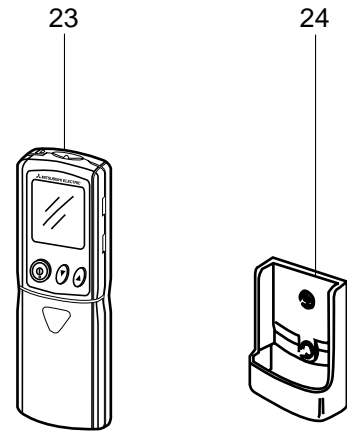
10	E02 527 620	INDOOR HEAT EXCHANGER			1	
11	E02 527 666	UNION (GAS)			1	φ5/8
12	E02 527 667	UNION (LIQUID)			1	φ3/8

## MS24WN (W)

### 12-3. INDOOR UNIT FUNCTIONAL PARTS AND ELECTRICAL PARTS



### 12-4. ACCESSORY AND REMOTE CONTROLLER



### 12-3. INDOOR UNIT FUNCTIONAL PARTS AND ELECTRICAL PARTS

Part numbers that are circled are not shown in the illustration.

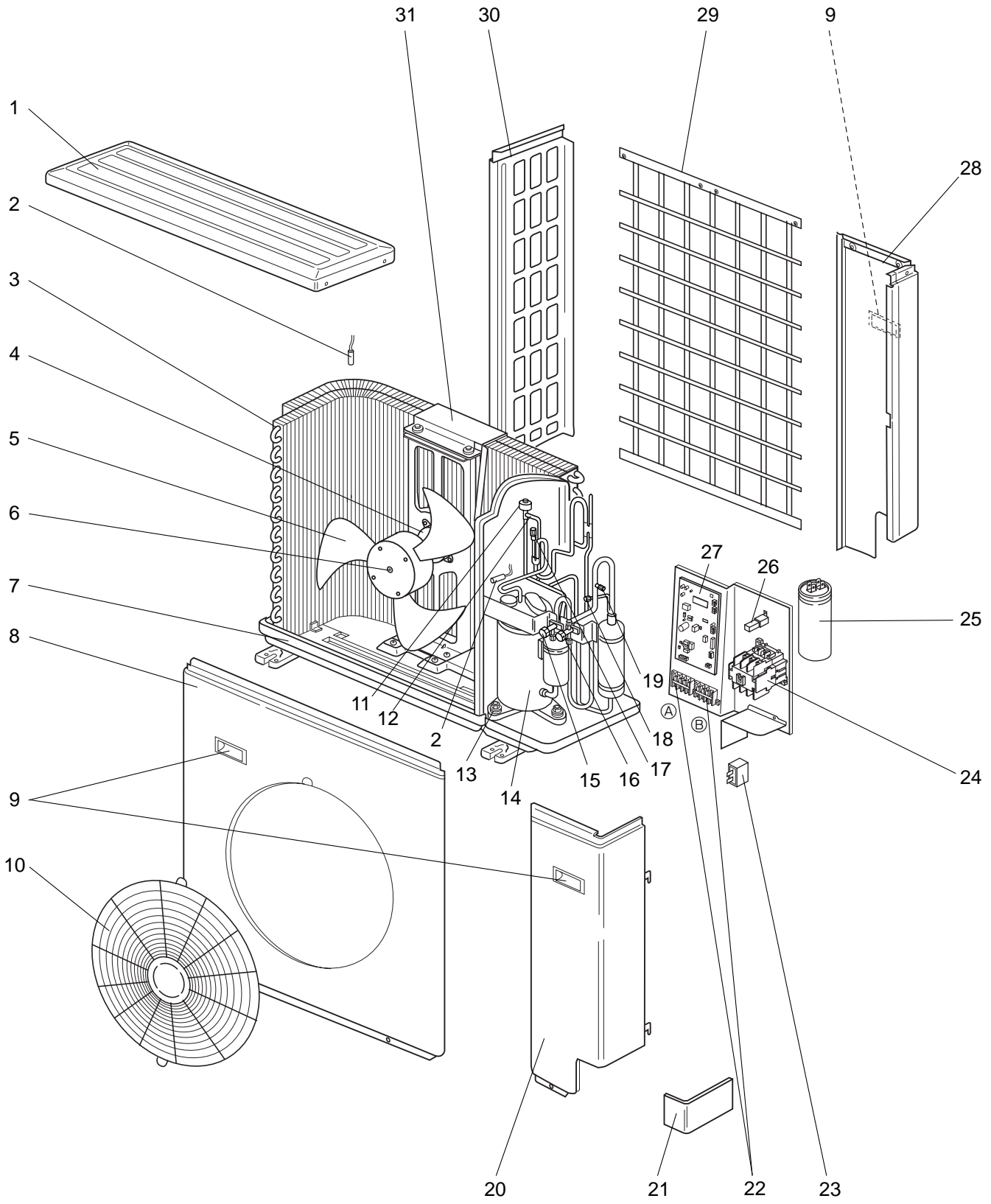
NO.	Part No.	Part Name	Symbol in Wiring Diagram	Q'ty/unit	Remarks
				MS24WN (W)	
1	E02 527 302	LINE FLOW FAN		1	
2	E02 408 509	BEARING MOUNT		1	
3	E02 001 504	SLEEVE BEARING		1	
4	E02 408 702	DRAIN HOSE		1	
5	E02 527 235	NOZZLE ASSEMBLY		1	
6	E02 527 040	VANE UPPER (W)		1	
7	E02 527 041	VANE LOWER (W)		1	
8	E02 784 382	FUSE	F11	1	3.15A
9	E02 784 385	VARISTOR	NR11	1	
10	E02 527 034	VANE CRANK SET		1	
11	E02 784 300	INDOOR FAN MOTOR ASSEMBLY	MF	1	RC4W33 -□□ Including RUBBER MOUNT
12	E02 448 303	VANE MOTOR (VERTICAL)	MV2	2	RIGHT & LEFT
13	E02 408 303	VANE MOTOR (HORIZONTAL)	MV1	1	UP & DOWN
14	E02 527 333	MOTOR BAND		1	
15	E02 528 329	DISPLAY P.C. BOARD		1	
16	E02 527 468	RECEIVER P.C. BOARD		1	
17	E02 784 452	ELECTRONIC CONTROL P.C. BOARD		1	AUTO RESTART Including No.16
18	E02 527 308	ROOM TEMPERATURE THERMISTOR	RT11	1	
19	E02 545 375	TERMINAL BLOCK	TB	1	
20	E02 527 307	INDOOR COIL THERMISTOR	RT12, RT13	1	
21	E02 528 034	VANE MOTOR SUPPORT SET(RIGHT)		1	
22	E02 529 034	VANE MOTOR SUPPORT SET(LEFT)		1	

### 12-4. ACCESSORY AND REMOTE CONTROLLER

23	E02 784 426	REMOTE CONTROLLER		1	
24	E02 527 083	REMOTE CONTROLLER HOLDER		1	

# MU24WN

## 12-5. OUTDOOR UNIT STRUCTURAL PARTS, ELECTRICAL PARTS AND FUNCTIONAL PARTS



## MU24WN

### 12-5. OUTDOOR UNIT STRUCTURAL PARTS, ELECTRICAL PARTS AND FUNCTIONAL PARTS

Part numbers that are circled are not shown in the illustration.

NO.	Part No.	Part Name	Symbol in Wiring Diagram	Q'ty/unit	Remarks
				MU24WN	
1	E02 813 297	TOP PANEL		1	NEW WHITE(Brighter)
2	E02 528 309	THERMISTOR	RT62, RT63	1	DISCHARGE, AMBIENT
3	E02 527 630	OUTDOOR HEAT EXCHANGER		1	
4	E02 784 301	OUTDOOR FAN MOTOR	MF	1	RA6N66-□□
5	E02 214 501	PROPELLER		1	
6	E07 070 508	PROPELLER NUT		1	
7	E02 813 290	BASE		1	NEW WHITE(Brighter)
8	E02 813 232	CABINET		1	NEW WHITE(Brighter)
9	E02 819 009	HANDLE		3	NEW WHITE(Brighter)
10	E02 784 521	FAN GUARD		1	NEW WHITE(Brighter)
11	E02 528 493	EXPANSION VALVE COIL	LEV	1	
12	E02 527 640	EXPANSION VALVE		1	
13	E02 527 506	COMPRESSOR RUBBER SET		4	4RUBBERS/SET
14	E02 784 900	COMPRESSOR	MC	1	PH33NPBT
15	E02 527 662	STOP VALVE (LIQUID)		1	φ3/8
16	E02 527 661	STOP VALVE (GAS)		1	φ5/8
17	E07 001 641	SERVICE PORT		1	
18	E07 012 641	SERVICE PORT		1	
19	E02 474 642	FUSIBLE PLUG		1	
20	E02 813 245	SERVICE PANEL		1	NEW WHITE(Brighter)
21	E02 813 006	COVER PANEL		1	NEW WHITE(Brighter)
22	E02 480 374	TERMINAL BLOCK	TB1	1	4P (FIGURE Ⓐ)
	E02 481 374	TERMINAL BLOCK	TB2	1	4P (FIGURE Ⓑ)
23	E02 784 351	OUTDOOR FAN CAPACITOR	C2	1	5.0μF/440VAC
24	E02 784 340	COMPRESSOR CONTACTOR	52C	1	
25	E02 544 353	COMPRESSOR CAPACITOR	C1	1	35μF/370VAC
26	E02 128 383	SURGE ABSORBER	DSAR	1	
27	E02 784 451	OUTDOOR ELECTRONIC CONTROL P.C. BOARD		1	
28	E02 813 522	REAR PANEL		1	NEW WHITE(Brighter)
29	E02 813 523	REAR GUARD		1	NEW WHITE(Brighter)
30	E02 814 249	SIDE PANEL		1	NEW WHITE(Brighter)
31	E02 527 515	MOTOR SUPPORT		1	
③②	E02 784 382	FUSE	F61	1	250V/3.15A
③③	E02 262 936	CAPILLARY TUBE		1	φ0.16×φ0.09×7-7/8
	E02 527 936	CAPILLARY TUBE		1	φ0.16×φ0.09×3-15/16
③④	E02 784 936	CAPILLARY TUBE (TAPER PIPE)		1	φ0.14×φ0.09×1-31/32

**13-1. REFRIGERANT PIPES**

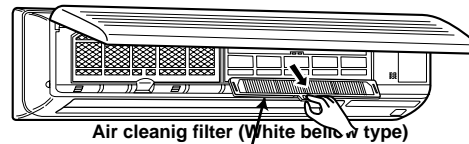
The air conditioner has flared connections its on indoor and outdoor sides.  
Please use the optional extension pipe as follows.

Model	Part No.	Pipe length	Cross-section	Pipe size		Insulation (in.)	Additional refrigerant charge R22(oz.)		
				A-Gas(in.)				B-Liquid(in.)	
				Outside diameter	Wall thickness			Outside diameter	Wall thickness
MS24WN MU24WN	MAC-860PI	10ft.		5/8	0.0315	3/8	0.0285	C 1-7/32 D 1-1/16	0 1.3 3.9
	MAC-861PI	16ft.							
	MAC-862PI	23ft.							
	MAC-863PI	33ft.							
	MAC-864PI	49ft.							

**13-2. AIR CLEANING FILTER**

- AIR CLEANING FILTER removes fine dust of 0.01 micron from air by means of static electricity.
- Normal life of AIR CLEANING FILTER is 4 months. However, when it becomes dirty, replace it as soon as possible.
- Clogged AIR CLEANING FILTER may reduce the air conditioner capacity or cause frost on the air outlet.
- DO NOT reuse AIR CLEANING FILTER even if it is washed.
- DO NOT remove or attach AIR CLEANING FILTER during unit operation.

Model	Part No.
MS24WN	MAC-1700FT

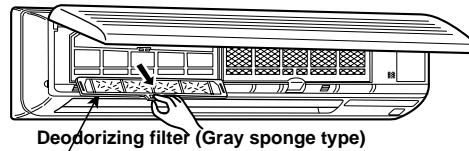


**13-3. DEODORIZING FILTER**

- DEODORIZING FILTER removes ammonia and hydrogen sulphide emitted from tobacco, and odor of pets.
- Clean DEODORIZING FILTER every two weeks. If the filter is particularly dirty, clean the filter more often.
- For cleaning, soak the filter in warm water for a while, and then wash and rinse it. Dry the filter in the shade thoroughly.
- When the filter color is still dark even after cleaning, replace the filter with a new one.  
Replace the filter at least once a year.

Model	Part No.
MS24WN	MAC-2200DF

- DEODORIZING FILTER and AIR CLEANING FILTER can be attached on either side.





**MITSUBISHI ELECTRIC**  
HVAC Advanced Products Division

---

3400 Lawrenceville Suwanee Road • Suwanee, Georgia 30024  
Toll Free: 800-433-4822 • Toll Free Fax: 800-889-9904  
[www.mrslim.com](http://www.mrslim.com)

**Specifications are subject to change without notice.**