

TECHNICAL & SERVICE MANUAL

Series PLFY Ceiling Cassettes R410A

Indoor unit

[Model Name]

[Service Ref.]

PLFY-P05NFMU-E

PLFY-P05NFMU-E.TH

PLFY-P08NFMU-E

PLFY-P08NFMU-E.TH

PLFY-P12NFMU-E

PLFY-P12NFMU-E.TH

PLFY-P15NFMU-E

PLFY-P15NFMU-E.TH

PLFY-P18NFMU-E

PLFY-P18NFMU-E.TH

Notes:

- This manual describes service data of the indoor units only.
- RoHS compliant products have <G> mark on spec name plate.

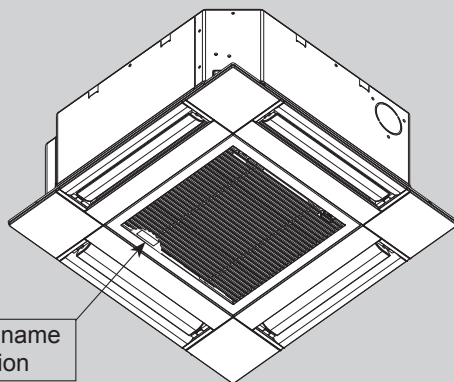

INDOOR UNIT

CONTENTS

1. SAFETY PRECAUTION.....	2
2. PARTS NAMES AND FUNCTIONS.....	4
3. SPECIFICATIONS.....	12
4. 4-WAY AIR FLOW SYSTEM.....	14
5. OUTLINES AND DIMENSIONS.....	16
6. WIRING DIAGRAM.....	17
7. REFRIGERANT SYSTEM DIAGRAM.....	18
8. TROUBLESHOOTING.....	19
9. DISASSEMBLY PROCEDURE.....	27

PARTS CATALOG (OCB604)

CAUTIONS RELATED TO NEW REFRIGERANT**Cautions for units utilizing refrigerant R410A****Do not use the existing refrigerant piping.**

The old refrigerant and lubricant in the existing piping contains a large amount of chlorine which may cause the lubricant deterioration of the new unit.

Use “low residual oil piping”

If there is a large amount of residual oil (hydraulic oil, etc.) inside the piping and joints, deterioration of the lubricant will result.

Store the piping indoors, and keep both ends of the piping sealed until just before brazing. (Leave elbow joints, etc. in their packaging.)

If dirt, dust or moisture enters into refrigerant cycle, that can cause deterioration of refrigerant oil or malfunction of equipment components.

The refrigerant oil applied to flare and flange connections must be ester oil, ether oil or alkylbenzene oil in a small amount.

If large amount of mineral oil enters, that can cause deterioration of refrigerant oil, etc.

Charge refrigerant from liquid phase of gas cylinder.

If the refrigerant is charged in a gas phase, composition change may occur in refrigerant and the efficiency will be lowered.

Do not use refrigerant other than R410A.

If other refrigerant (R22, etc.) is used, chlorine in refrigerant can cause deterioration of refrigerant oil, etc.

Use a vacuum pump with a reverse flow check valve.

Vacuum pump oil may flow back into refrigerant cycle and that can cause deterioration of refrigerant oil, etc.

Use the following tools specifically designed for use with R410A refrigerant.

The following tools are necessary to use R410A refrigerant.

Tools for R410A	
Gauge manifold	Flare tool
Charge hose	Size adjustment gauge
Gas leak detector	Vacuum pump adaptor
Torque wrench	Electronic refrigerant charging scale
Micron gauge	

Handle tools with care.

If dirt, dust or moisture enters into refrigerant cycle, that can cause deterioration of refrigerant oil or malfunction of compressor.

Do not use a charging cylinder.

If a charging cylinder is used, the composition of refrigerant will change and the efficiency will be lowered.

Use the specified refrigerant only.**Never use any refrigerant other than that specified.**

Doing so may cause a burst, an explosion, or fire when the unit is being used, serviced, or disposed of. Correct refrigerant is specified in the manuals and on the spec labels provided with our products. We will not be held responsible for mechanical failure, system malfunction, unit breakdown or accidents caused by failure to follow the instructions.

Ventilate the room if refrigerant leaks during operation. If refrigerant comes into contact with a flame, poisonous gases will be released.

[1] Cautions for service

- (1) Perform service after recovering the refrigerant left in unit completely.
- (2) Do not release refrigerant in the air.
- (3) After completing service, charge the cycle with specified amount of refrigerant.
- (4) When performing service, install a filter drier simultaneously.
Be sure to use a filter drier for new refrigerant.

[2] Additional refrigerant charge

When charging directly from cylinder

- Check that cylinder for R410A on the market is a syphon type.
- Charging should be performed with the cylinder of syphon standing vertically. (Refrigerant is charged from liquid phase.)

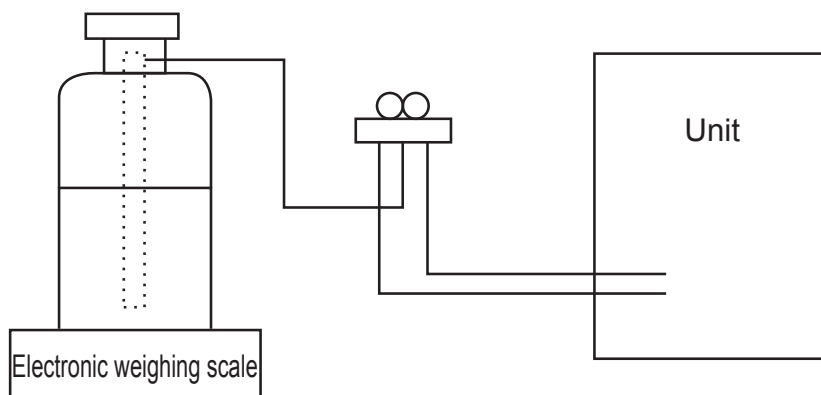

[3] Service tools

Use the below service tools as exclusive tools for R410A refrigerant.

No.	Tool name	Specifications
①	Gauge manifold	· Only for R410A
		· Use the existing fitting specifications. (UNF1/2)
		· Use high-tension side pressure of 5.3MPa·G or over.
②	Charge hose	· Only for R410A
		· Use pressure performance of 5.09MPa·G or over.
③	Electronic weighing scale	—
④	Gas leak detector	· Use the detector for R134a, R407C or R410A.
⑤	Adaptor for reverse flow check	· Attach on vacuum pump.
⑥	Refrigerant charge base	—
⑦	Refrigerant cylinder	· Only for R410A · Top of cylinder (Pink)
		· Cylinder with syphon
⑧	Refrigerant recovery equipment	—
⑨	Micron gauge	—

2

PARTS NAMES AND FUNCTIONS

2-1. Indoor Unit

Horizontal Air Outlet

Sets horizontal airflow automatically during cooling or dehumidifying.

Filter

Removes dust and pollutants from drawn in air.

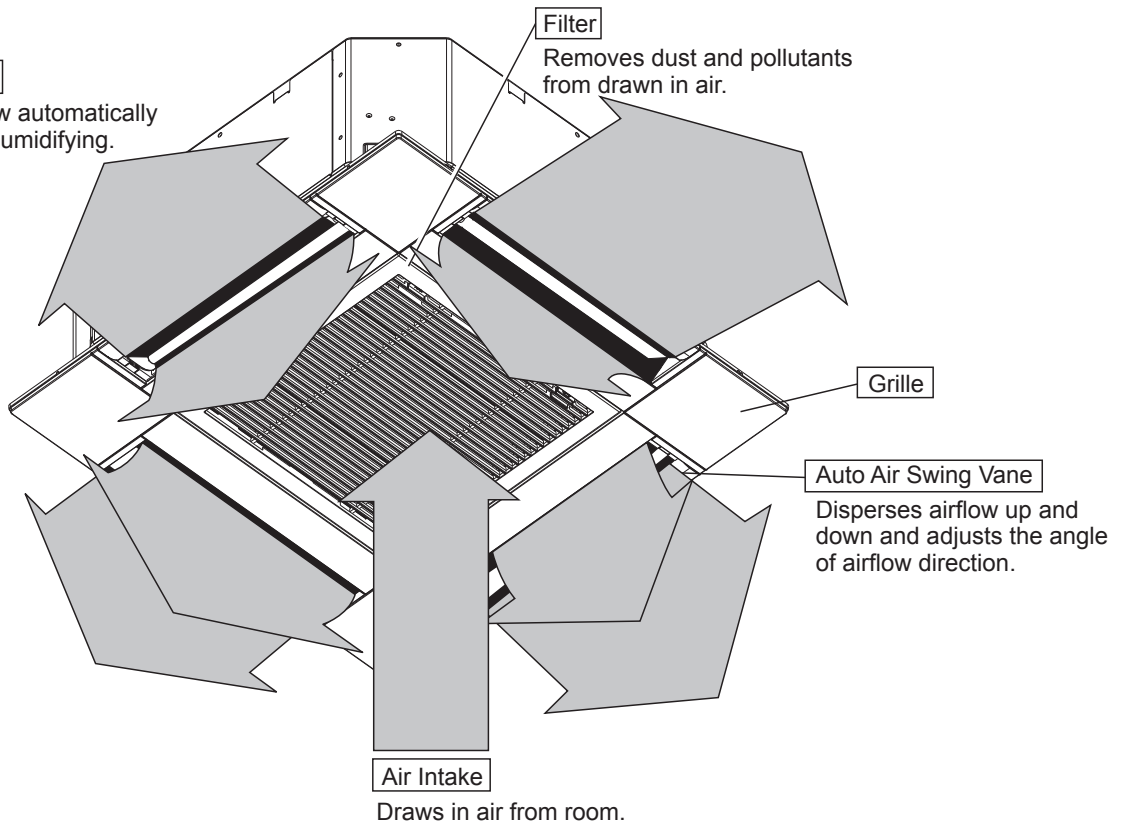

Air Intake

Draws in air from room.

Grille

Auto Air Swing Vane

Disperses airflow up and down and adjusts the angle of airflow direction.

2-2. Wired Remote Controller <PAR-32MAA> <PAC-YT53CRAU>

Wired remote controller function

The functions which can be used are restricted according to each model.

○ : Supported ✕ : Unsupported

	Function		PAR-32MAA		PAC-YT53CRAU
			Slim	City multi	
Body	Product size H × W × D	(mm) (inch)	(120 × 120 × 19) (4-3/4 × 4-3/4 × 3/4)		(120 × 70 × 14.5) (4-3/4 × 2-3/4 × 9/16)
	LCD		Full Dot LCD		Partial Dot LCD
	Backlight		○		○
Energy-saving	Energy-saving operation schedule		○	✕	✕
	Automatic return to the preset temperature		○		✕
Restriction	Setting the temperature range restriction		○		○
Function	Operation lock function		○		○
	Weekly timer		○		✕
	ON/OFF timer		○		✕
	High Power		○	✕	✕
	Manual vane angle		○		✕

2-2-1. Wired Remote Controller <PAR-32MAA>

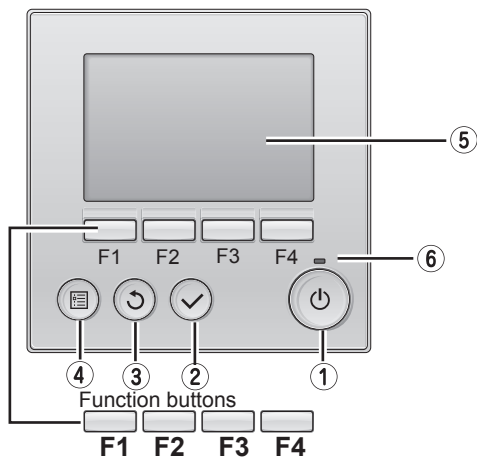

① ON/OFF button

Press to turn ON/OFF the indoor unit.

② SELECT button

Press to save the setting.

③ RETURN button

Press to return to the previous screen.

④ MENU button

Press to bring up the Main menu.

⑤ Backlit LCD

Operation settings will appear.
When the backlight is off, pressing any button turns the backlight on and it will stay lit for a certain period of time depending on the screen.

When the backlight is off, pressing any button turns the backlight on and does not perform its function. (except for the  (ON/OFF) button)

The functions of the function buttons change depending on the screen. Refer to the button function guide that appears at the bottom of the LCD for the functions they serve on a given screen.

When the system is centrally controlled, the button function guide that corresponds to the locked button will not appear.

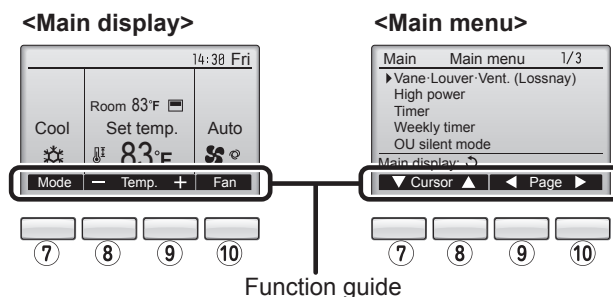

⑥ ON/OFF lamp

This lamp lights up in green while the unit is in operation. It blinks while the remote controller is starting up or when there is an error.

⑦ Function button **F1**

Main display : Press to change the operation mode.
Main menu : Press to move the cursor down.

⑧ Function button **F2**

Main display : Press to decrease temperature.
Main menu : Press to move the cursor up.

⑨ Function button **F3**

Main display : Press to increase temperature.
Main menu : Press to go to the previous page.

⑩ Function button **F4**

Main display : Press to change the fan speed.
Main menu : Press to go to the next page.

The main display can be displayed in 2 different modes: "Full" and "Basic".

The initial setting is "Full". To switch to the "Basic" mode, change the setting on the Main display setting.

<Full mode>

All icons are displayed for explanation.

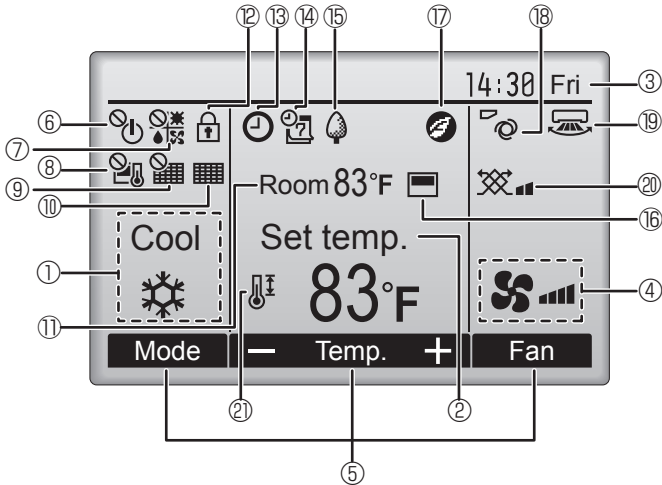

<Basic mode>

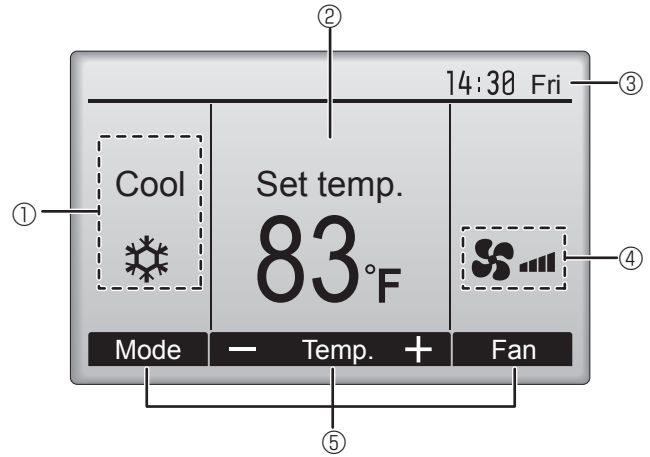

① Operation mode

Indoor unit operation mode appears here.

② Preset temperature

Preset temperature appears here.

③ Clock (See the Installation Manual.)

Current time appears here.

④ Fan speed

Fan speed setting appears here.

⑤ Button function guide

Functions of the corresponding buttons appear here.



Appears when the ON/OFF operation is centrally controlled.



Appears when the operation mode is centrally controlled.



Appears when the preset temperature is centrally controlled.



Appears when the filter reset function is centrally controlled.



Indicates when filter needs maintenance.

⑪ Room temperature (See the Installation Manual.)

Current room temperature appears here.



Appears when the buttons are locked.



Appears when the On/Off timer or Night setback function is enabled.



Appears when the Weekly timer is enabled.



Appears while the units are operated in the energy-save mode.



Appears when the built-in thermistor on the remote controller is activated to monitor the room temperature.

appears when the thermistor on the indoor unit is activated to monitor the room temperature.



Appears when the units are operated in the energy-save mode with 3D i-see Sensor.



Indicates the vane setting.



Indicates the louver setting. (This function is not available on this unit.)



Indicates the ventilation setting.



Appears when the preset temperature range is restricted.

Most settings (except ON/OFF, mode, fan speed, temperature) can be made from the Menu screen.

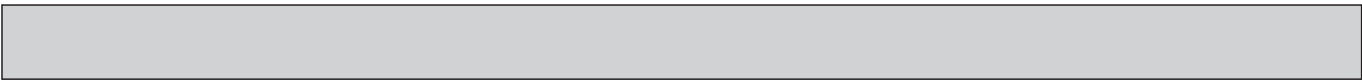

Main menu

Press the **MENU** button.
Move the cursor to the desired item with the **F1** and **F2** buttons, and press the **SELECT** button.

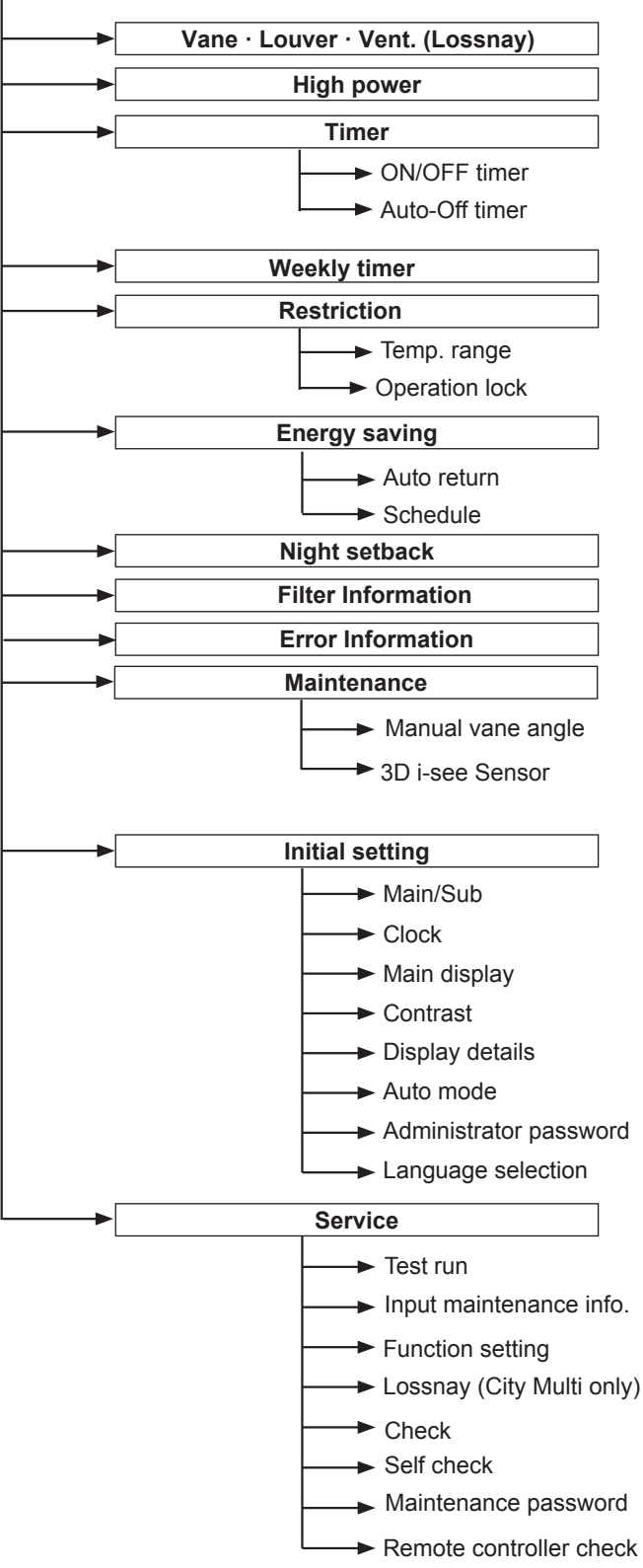

Not all functions are available on all models of indoor units.

Main menu list

Setting and display items		Setting details
Vane · Louver · Vent. (Lossnay)		<p>Use to set the vane angle.</p> <ul style="list-style-type: none"> • Select a desired vane setting from 5 different settings. <p>Use to turn ON/OFF the louver.</p> <ul style="list-style-type: none"> • Select a desired setting from "ON" and "OFF." <p>Use to set the amount of ventilation.</p> <ul style="list-style-type: none"> • Select a desired setting from "Off," "Low," and "High."
High power		<p>Use to reach the comfortable room temperature quickly.</p> <ul style="list-style-type: none"> • Units can be operated in the High-power mode for up to 30 minutes.
Timer	ON/OFF timer*	<p>Use to set the operation ON/OFF times.</p> <ul style="list-style-type: none"> • Time can be set in 5-minute increments.
	Auto-Off timer	<p>Use to set the Auto-Off time.</p> <ul style="list-style-type: none"> • Time can be set to a value from 30 to 240 in 10-minute increments.
Weekly timer*		<p>Use to set the weekly operation ON/OFF times.</p> <ul style="list-style-type: none"> • Up to 8 operation patterns can be set for each day. (Not valid when the ON/OFF timer is enabled.)
Restriction	Temp. range	<p>Use to restrict the preset temperature range.</p> <ul style="list-style-type: none"> • Different temperature ranges can be set for different operation modes.
	Operation lock	<p>Use to lock selected functions.</p> <ul style="list-style-type: none"> • The locked functions cannot be operated.
Energy saving	Auto return	<p>Use to get the units to operate at the preset temperature after performing energy-save operation for a specified time period.</p> <ul style="list-style-type: none"> • Time can be set to a value from 30 and 120 in 10-minute increments. (This function will not be valid when the preset temperature ranges are restricted.)
	Schedule*	<p>Set the start/stop times to operate the units in the energy-save mode for each day of the week, and set the energy-saving rate.</p> <ul style="list-style-type: none"> • Up to 4 energy-save operation patterns can be set for each day. • Time can be set in 5-minute increments. • Energy-saving rate can be set to a value from 0% or 50 to 90% in 10% increments.
Night setback*		<p>Use to make Night setback settings.</p> <ul style="list-style-type: none"> • Select "Yes" to enable the setting, and "No" to disable the setting. The temperature range and the start/stop times can be set.
Filter information		<p>Use to check the filter status.</p> <ul style="list-style-type: none"> • The filter sign can be reset.
Error information		<p>Use to check error information when an error occurs.</p> <ul style="list-style-type: none"> • Check code, error source, refrigerant address, unit model, manufacturing number, contact information (dealer's phone number) can be displayed. (The unit model, manufacturing number, and contact information need to be registered in advance to be displayed.)
Maintenance	Manual vane angle	<p>Use to set the vane angle for each vane to a fixed position.</p>
	3D i-see Sensor	<p>Use to set the following functions for 3D i-see Sensor.</p> <ul style="list-style-type: none"> • Air distribution • Energy saving option • Seasonal airflow
Initial setting	Clock	<p>Use to set the current time.</p>
	Main display	<p>Use to switch between "Full" and "Basic" modes for the Main display.</p> <ul style="list-style-type: none"> • The initial setting is "Full."
	Contrast	<p>Use to adjust screen contrast.</p>
	Language selection	<p>Use to select the desired language.</p>

Continue to the next page

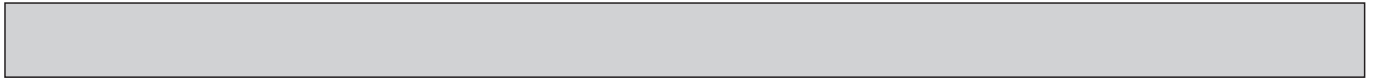

Setting and display items		Setting details
	Input maintenance	Select "Input maintenance Info." from the Service menu to bring up the Maintenance information screen. The following settings can be made from the Maintenance Information screen. • Model name input • Serial No. input • Dealer information input
	LOSSNAY setting	This setting is required only when the operation of City Multi units is interlocked with LOSSNAY units.
	Check	Error history: Display the error history and execute delete error history.
	Self check	Error history of each unit can be checked via the remote controller.
	Maintenance password	Use to change the maintenance password.
	Remote controller check	When the remote controller does not work properly, use the remote controller checking function to troubleshoot the problem.

2-2-2. Wired Remote Controller <PAC-YT53CRAU>

Note:

The phrase "Wired remote controller" in this manual refers only to the **PAC-YT53CRAU**.

If you need any information for the other remote controller, please refer to either the installation manual or initial setting manual which are included in remote controller's box.

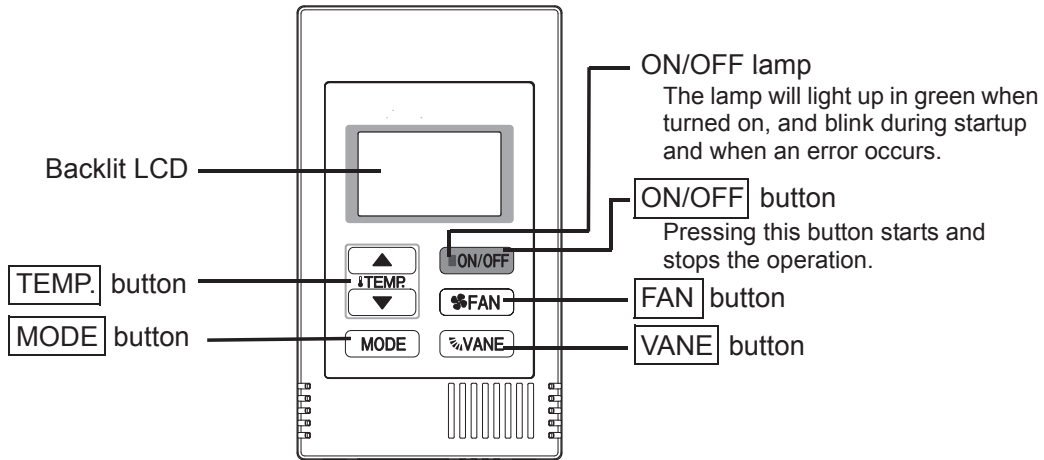

Note: To set the functions that are not available on this controller (**PAC-YT53CRAU**) such as Louver, use the centralized controller.

Display section

Note: All icons are displayed for explanation purpose

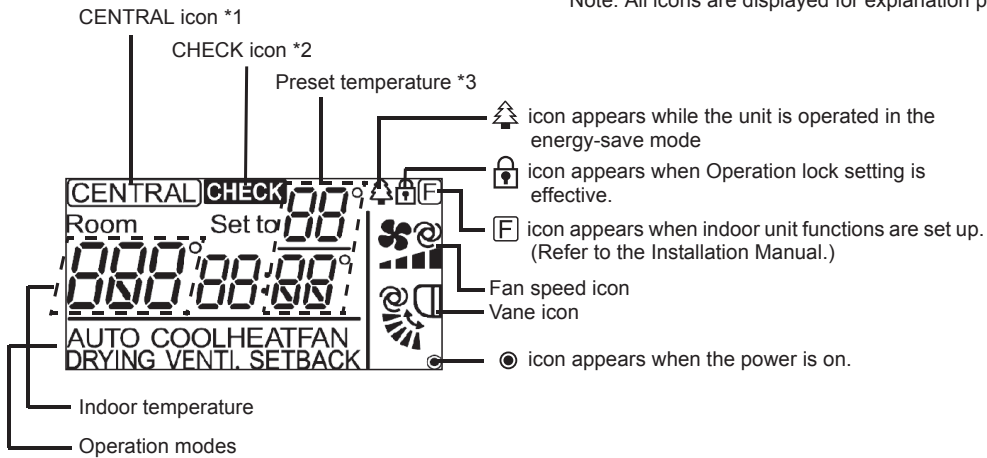

*1 **CENTRAL** icon

Appears when one of the following local operations is prohibited: ON/OFF; operation mode; preset temperature; fan speed; vane.

*2 **CHECK** icon

For City Multi, when an error occurs, power indicator will blink, and unit address (3 digits) and check code (4 digits) will blink.

Check the error status, stop the operation, and consult your dealer.

*3 Preset temperature

* Centigrade or Fahrenheit is selectable. Refer to the Installation Manual for details.

In COOL, DRYING, HEAT, or AUTO (single set point) modes

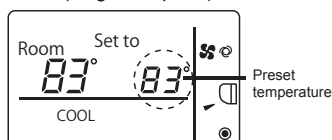

In AUTO (dual set point) or SETBACK modes

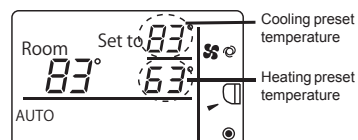

2-3. Wireless remote controller

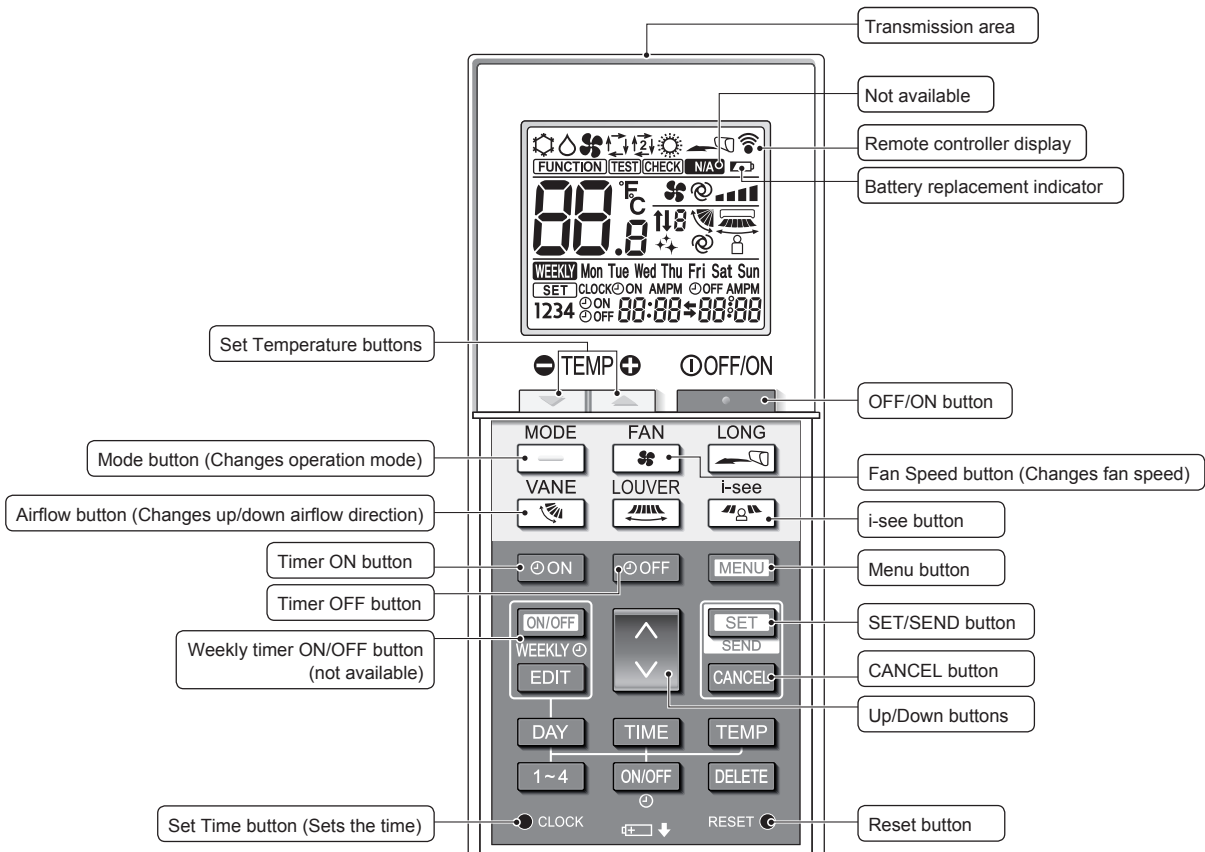

Operation mode

	Cool		Dry
	Fan		Auto
	Heat		

Temperature setting
The units of temperature can be changed. For details, refer to the Installation Manual.

Vane setting
Step 1 Step 2 Step 3 Step 4 Step 5 Swing Auto

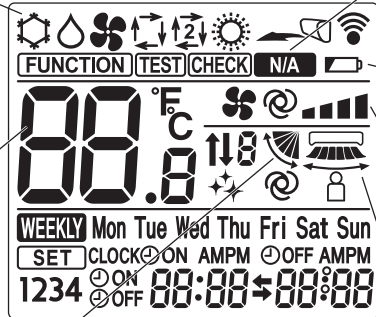

Not available
Appears when a non-supported function is selected.

Battery replacement indicator
Appears when the remaining battery power is low.

Fan speed setting

3D i-see sensor (Air distribution)
Default Direct Indirect

When Direct or Indirect is selected, the vane setting is set to "Auto".

3-1. SPECIFICATIONS

Service Ref.	PLFY-P05NFMU-E.TH	PLFY-P08NFMU-E.TH	PLFY-P12NFMU-E.TH	PLFY-P15NFMU-E.TH	PLFY-P18NFMU-E.TH		
power source	single phase, 208/230V, 60 Hz						
cooling capacity *1	kW	1.4	2.3	3.5	4.3	5.2	
	*1 BTU/h	5,000	8,000	12,000	15,000	18,000	
	Power input kW	0.02	0.02	0.02	0.03	0.04	
	Current input A	0.19	0.22	0.23	0.28	0.40	
Heating capacity *3	kW	1.6	2.6	3.9	4.9	5.8	
	*3 BTU/h	5,600	9,000	13,500	17,000	20,000	
	Power input kW	0.02	0.02	0.02	0.03	0.04	
	Current input A	0.14	0.17	0.18	0.23	0.35	
External finish	Galvanized steel sheet						
External dimension	mm	208×570×570					
H × W × D	in	8-3/16"×22-7/16"×22-7/16"					
Net weight	kg (lb)	13.1 (28.9)	13.1 (28.9)	14.2(31.3)	14.2(31.3)	14.2(31.3)	
Decoration panel	model	SLP-18FAU					
	External finish	Munsell 1.0Y 9.2/0.2					
	Dimension	10 × 625 × 625					
	H × W × D	13/32"×24-19/32"×24-19/32"					
	Net weight	2.4(5.3)					
Heat exchanger	Cross fin (Aluminum fin and copper tube)						
FAN	Type	Turbo fan × 1					
	External static pressure	0 Pa (0 mmH ₂ O)					
	Motor type	DC motor					
	Motor output kW	0.05					
	Driving mechanism	Direct driven					
	Airflow rate	m ³ /min	6.5-7.5-8.0	6.5-8.0-9.0	7.0-8.0-9.5	7.5-9.0-11.0	9.0-11.0-13.0
		L/s	108-125-133	108-133-150	117-133-158	125-150-183	150-183-217
		cfm	230-265-280	230-280-315	245-280-335	265-315-390	315-390-460
Noise level (Low-Mid-High) (measured in anechoic room)	dB <A>	26-28-30	26-30-33	26-30-34	28-33-39	33-39-43	
Insulation material	PS						
Air filter	PP honeycomb fabric (long life type)						
Protection device	Fuse						
Refrigerant control device	LEV						
Connectable outdoor unit	R410A CITY MULTI						
Diameter of refrigerant pipe	Liquid	ø6.35 (ø1/4") Flare					
	Gas	ø12.7 (ø1/2") Flare					
Field drain pipe size	mm (in)	O.D. 32 mm (1-1/4") (PVC pipe VP-25 connectable)					
Standard attachment	Installation manual, Instruction book						
Remark	Optional parts	Decoration panel : SLP-18FAU, SLP-18FAEU *PLFY-P NFMU-E should be used together with decoration panel.					
	Installation	Details on foundation work, duct work, insulation work, electrical wiring, power source switch, and other items shall be referred to the Installation Manual.					

*1 Nominal cooling condition indoor : 27°CDB/19°CWB (81°FDB/66°FWB) Outdoor : 35°CDB (95°FDB) Pipe length : 7.5m (24-9/16 ft) Level difference : 0m (0 ft)	*2 Nominal heating condition 20°CDB (68°FDB) 7°CDB/6°CWB (45°FDB/43°FWB) 7.5 m (24-9/16 ft) 0 m (0 ft)	Unit converter kcal= kW × 860 BTU/h =3,412 cfm = K/min × 35.31 lb = kg/0.4536
Notes: 1. Nominal conditions *1 and *2 are subject to JIS B8615-1. 2. Due to continuing improvement, above specification may be subject to change without notice.		

3-2. ELECTRICAL PARTS SPECIFICATIONS

Parts name	Service ref.	Symbol	PLFY-P05NFMU-E.TH	PLFY-P08NFMU-E.TH	PLFY-P12NFMU-E.TH	PLFY-P15NFMU-E.TH	PLFY-P18NFMU-E.TH	
Thermistor (Room temperature detection)		TH21	Resistance 30°F/15.8Ω, 50°F/9.6Ω, 70°F/6.0Ω, 80°/4.8Ω, 90°F/3.9Ω, 100°F/3.2Ω					
Thermistor (Pipe temperature detection/Liquid)		TH22	Resistance 30°F/15.8Ω, 50°F/9.6Ω, 70°F/6.0Ω, 80°/4.8Ω, 90°F/3.9Ω, 100°F/3.2Ω					
Thermistor (Pipe temperature detection/Gas)		TH23	Resistance 30°F/15.8Ω, 50°F/9.6Ω, 70°F/6.0Ω, 80°/4.8Ω, 90°F/3.9Ω, 100°F/3.2Ω					
Fuse (Indoor controller board)		FUSE	250V 6.3A					
Fan motor		MF	OUTPUT 50 W					
Vane motor		MV	MSBPC20M32 (green label)/MSBPC20M33 (blue label) DC12V 300Ω/phase					
Drain pump		DP	PMD-12D13ME INPUT 3W (DC 13V) 24 ℓ /Hr					
Drain float switch		FS	Open/short detection					
Linear expansion valve [coil]		LEV	DC12V Stepping motor drive, Port dimension φ5.2 (0-2000pulse) EDM-40YGME					
Power supply terminal block		TB2	(L1, L2) Rated to 330V 30A*					
Transmission terminal block		TB5	(M1, M2, S) Rated to 250V 20A*					
MA remote controller terminal block		TB15	(1, 2) Rated to 250V 10A*					

* Refer to WIRING DIAGRAM for the supplied voltage.

4-1. FRESH AIR INTAKE (Location for installation)

At the time of installation, use the duct holes (cut out) located at the positions shown in following diagram, as and when required.

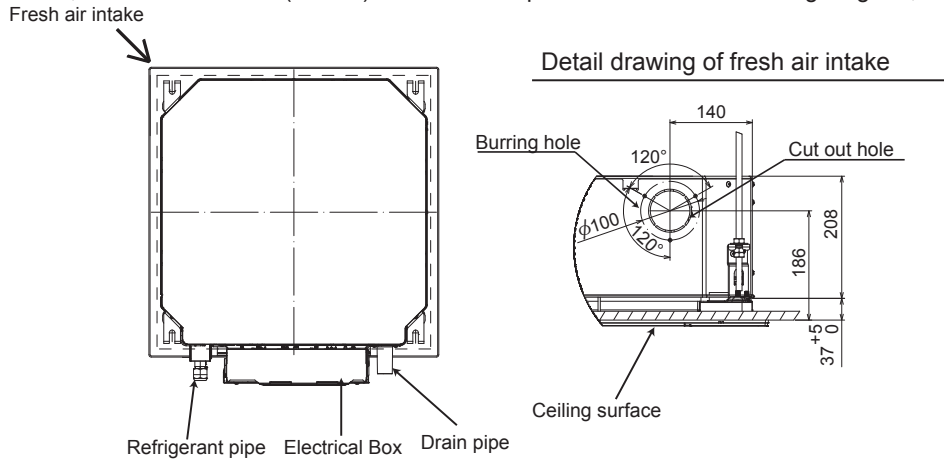

4-2. FRESH AIR INTAKE AMOUNT & STATIC PRESSURE CHARACTERISTICS

PLFY-P05NFMU-E.TH
PLFY-P15NFMU-E.TH

PLFY-P08NFMU-E.TH
PLFY-P18NFMU-E.TH

PLFY-P12NFMU-E.TH

Taking air into the unit

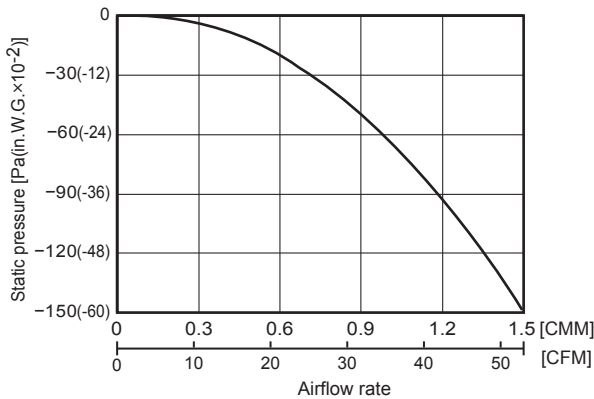

How to read curves

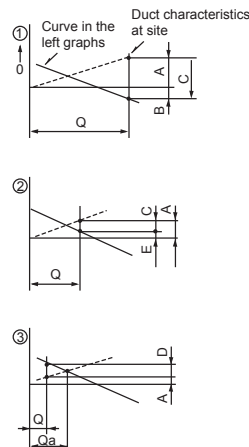

- Q...Designed amount of fresh air intake $\lt; m^3/min \gt$
- A...Static pressure loss of fresh air intake duct system with air flow amount Q $\lt; Pa \gt$
- B...Forced static pressure at air conditioner inlet with air flow amount Q $\lt; Pa \gt$
- C...Static pressure of booster fan with air flow amount Q $\lt; Pa \gt$
- D...Static pressure loss increase amount of fresh air intake duct system for air flow amount Q $\lt; Pa \gt$
- E...Static pressure of indoor unit with air flow amount Q $\lt; Pa \gt$
- Qa...Estimated amount of fresh air intake without D $\lt; m^3/min \gt$

NOTE: Fresh air intake amount should be 10% or less of whole air amount to prevent dew dripping.

4-3. OPERATION IN CONJUNCTION WITH DUCT FAN (Booster fan)

• Whenever the indoor unit operates, the duct fan also operates.

- (1) Connect the optional multiple remote controller adapter (PAC-SA88HA-E) to the connector CN51 on the indoor controller board.
 - (2) Drive the relay after connecting the 12 V DC relay between the Yellow and Orange connector wires.
- MB: Electromagnetic switch power relay for duct fan.
X: Auxiliary relay
(For 12 V DC, coil rating: 1.0 W or below)

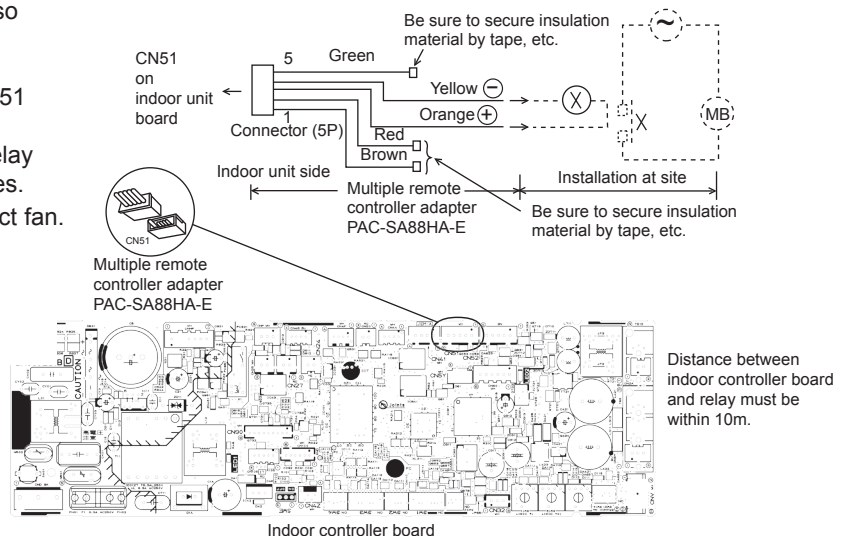

4-4. FIXING HORIZONTAL VANE

Horizontal vane of each air outlet can be fixed according to the environment where it is installed.

Setting procedures

- 1) Turn off a main power supply (Turn off a breaker).
- 2) Disconnect the vane motor connector of the direction of the arrow with pressing the unlocking button as shown in figure below.
Insulate the disconnected connector with the plastic tape.

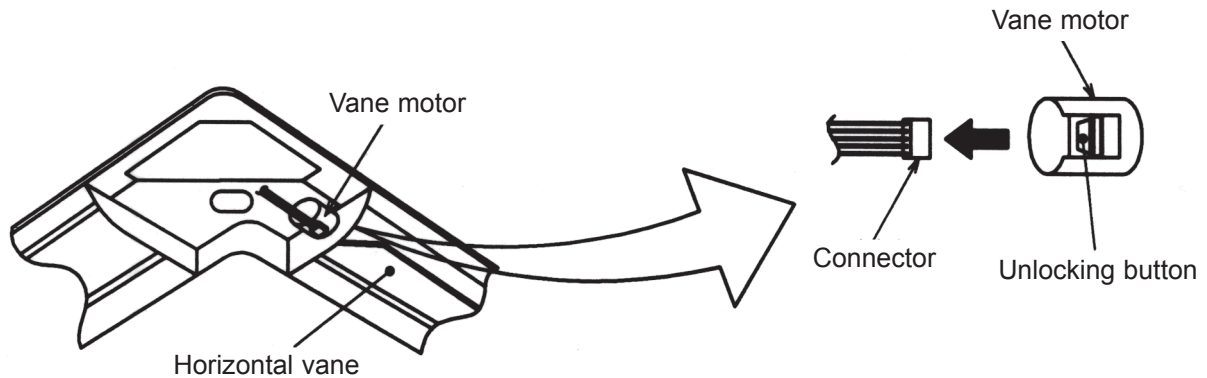

- 3) Set the vertical vane of the air outlet by hand slowly within the range in the table below.

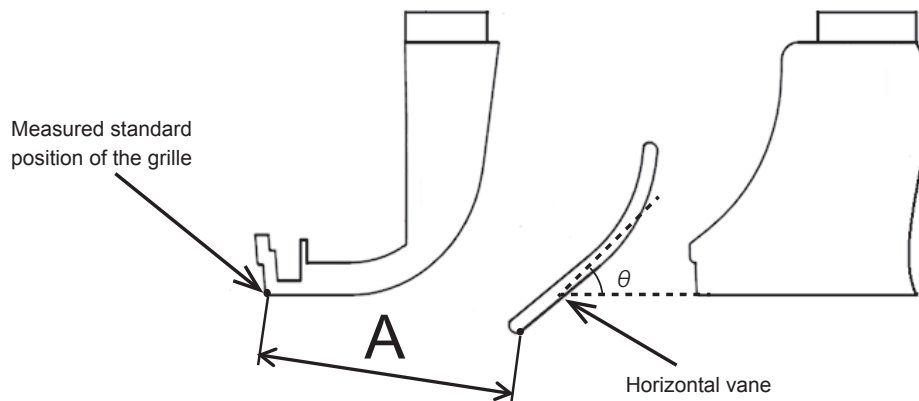

<Set range>

Standard of horizontal position	Angle $\theta = 21^\circ$ (Horizontal)	Angle $\theta = 24^\circ$	Angle $\theta = 39^\circ$	Angle $\theta = 42^\circ$	Angle $\theta = 45^\circ$ (Downward)
Dimension A inch (mm)	1-17/32 (39)	1-39/64 (41)	1-27/32(47)	1-57/64(48)	1-57/64(49)

Note: Dimension between 1-17/32 (39) and 1-57/64(49) can be arbitrarily set.

Caution 	Do not set the dimension out of the range.
	Erroneous setting could cause dew drips or malfunction of unit.

PLFY-P05NFMU-E.TH
PLFY-P15NFMU-E.TH

PLFY-P08NFMU-E.TH
PLFY-P18NFMU-E.TH

PLFY-P12NFMU-E.TH

Unit: inch(mm)

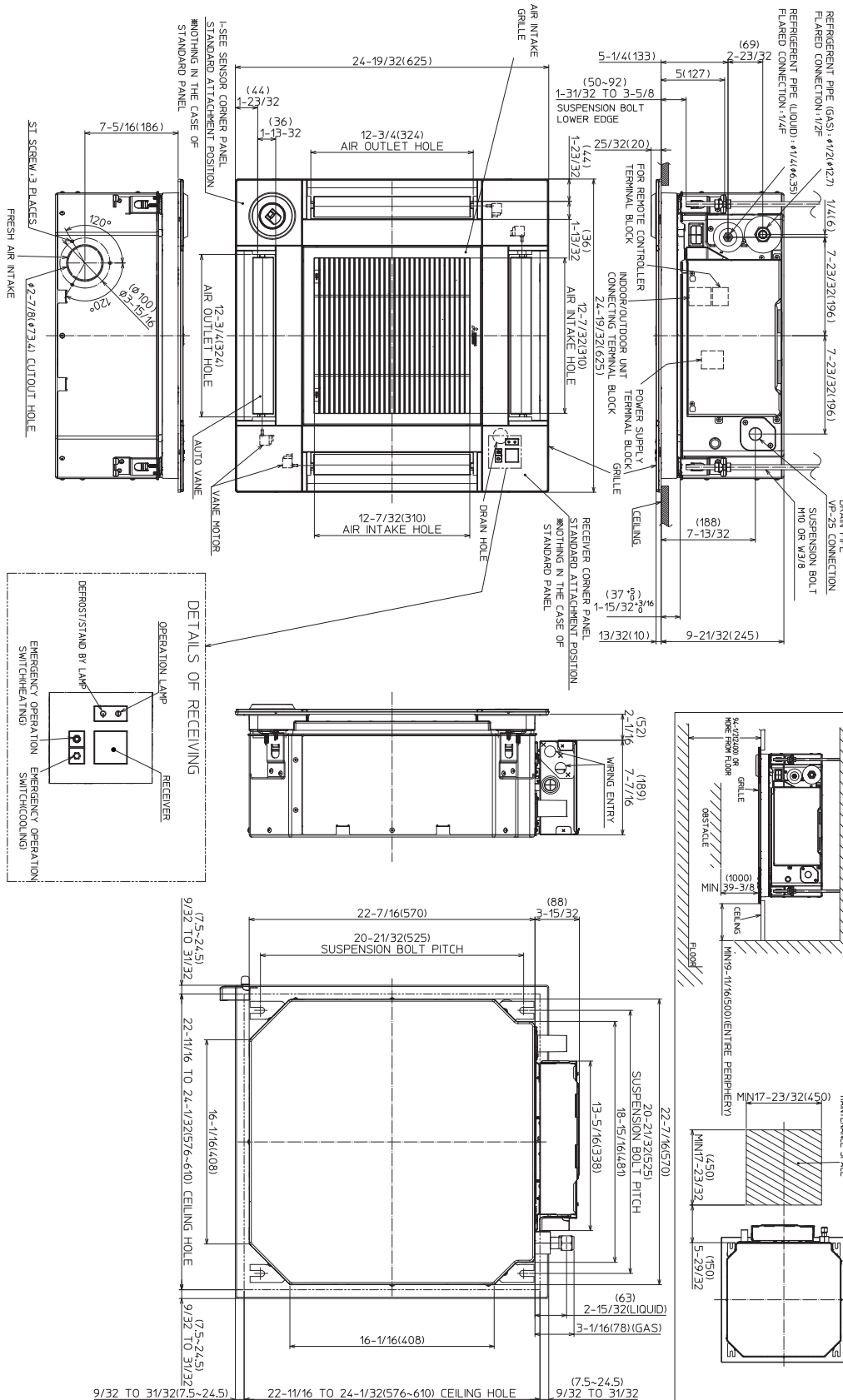

PLFY-P05NFMU-E.TH
PLFY-P15NFMU-E.TH

PLFY-P08NFMU-E.TH
PLFY-P18NFMU-E.TH

PLFY-P12NFMU-E.TH

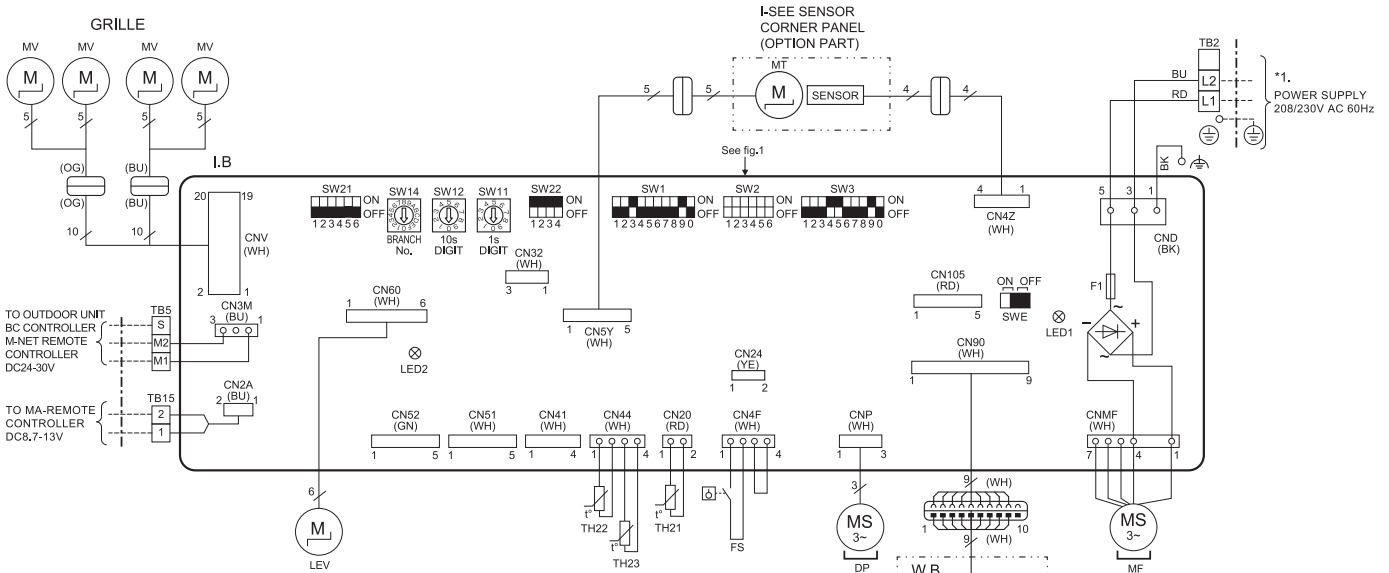

[LEGEND]

SYMBOL	NAME
I.B	INDOOR CONTROLLER BOARD
CN24	EXTERNAL HEATER
CN32	REMOTE SWITCH
CN41	HA TERMINAL-A
CN51	CENTRALLY CONTROL
CN52	REMOTE INDICATION
CN105	IT TERMINAL
F1	FUSE (UL 6.3A 250V AC)
LED1	POWER SUPPLY (I.B)
LED2	POWER SUPPLY (MA-REMOTE CONTROLLER)
SW1	MODE SELECTION
SW2	CAPACITY CODE
SW3	MODE SELECTION
SW11	ADDRESS SETTING ONES DIGIT
SW12	ADDRESS SETTING TENS DIGIT
SW14	BRANCH No.
SW21	CEILING HEIGHT SELECTOR
SW22	PAIR NO. SETTING
SWE	DRAIN PUMP(TEST MODE)
DP	DRAIN PUMP
LEV	LINEAR EXPANSION VALVE
MF	FAN MOTOR
MV	VANE MOTOR
FS	FLOAT SWITCH
TB2	TERMINAL POWER SUPPLY
TB5	BLOCK TRANSMISSION
TB15	MA-REMOTE CONTROLLER
TH21	ROOM TEMP. THERMISTOR
TH22	PIPE TEMP. THERMISTOR/LIQUID
TH23	PIPE TEMP. THERMISTOR/GAS
OPTION PART	
W.B	WIRELESS REMOTE CONTROLLER BOARD
BZ	BUZZER
LED1	OPERATION (GREEN)
LED2	STAND BY (ORANGE)
RU	RECEIVING UNIT
SW1	EMERGENCY OPERATION(HEAT)
SW2	EMERGENCY OPERATION(COOL)
MT	I-SEE SENSOR MOTOR

<fig.1>

MODELS	SW2	MODELS	SW2
P05	ON OFF 123456	P15	ON OFF 123456
P08	ON OFF 123456	P18	ON OFF 123456
P12	ON OFF 123456		

The black square (■) indicates a switch position.

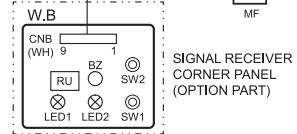

Notes:

- 1.At servicing for outdoor unit,always follow the wiring diagram of outdoor unit.
- 2.In case of using MA-Remote controller, please connect to TB15.
(Remote controller wire is non-polar.)
- 3.In case of using M-NET, please connect to TB5. (Transmission line is non-polar.)
- 4.Symbol [S]of TB5 is the shield wire connection.
- 5.Symbols used in wiring diagram above are, [] : terminal block, [] : connector.
- 6.The setting of the SW2 dip switches differs in the capacity. For the detail, refer to the fig.1.
- 7.Make sure to turn off the indoor and the outdoor units before replacing indoor controller board.

*1. Use copper supply wires.
Utilisez des fils d'alimentation en cuivre.

7

REFRIGERANT SYSTEM DIAGRAM

PLFY-P05NFMU-E.TH
 PLYF-P15NFMU-E.TH

PLFY-P08NFMU-E.TH
 PLYF-P18NFMU-E.TH

PLFY-P12NFMU-E.TH

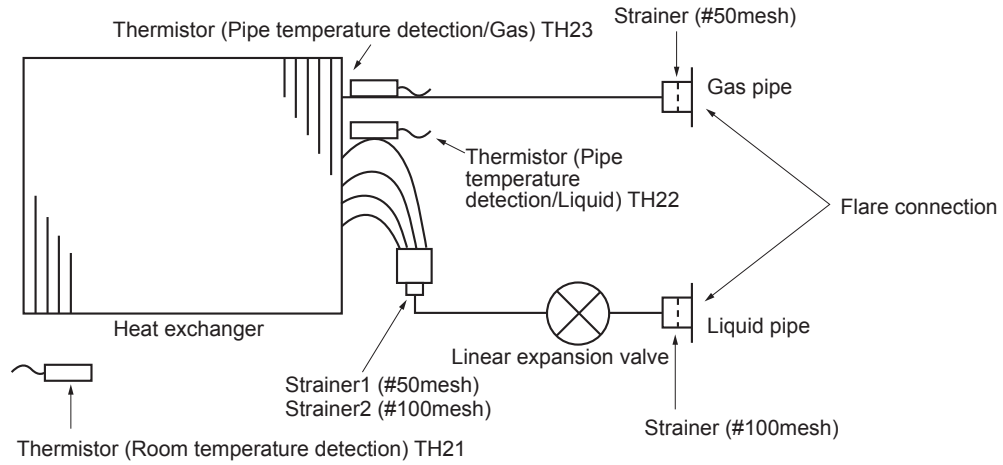

Unit: inch (mm)

Gas pipe	$\phi 1/2(12.7)$
Liquid pipe	$\phi 1/4(6.35)$

8-1. COUNTERMEASURES FOR ERROR DURING TEST RUN

If a problem occurs during test run, a code number will appear on the remote controller (or LED on the outdoor unit), and the air conditioning system will automatically cease operating.

Refer to the connected outdoor unit service manual in order to determine the nature of the abnormality and apply corrective measure.

Check code	Trouble	Detected Unit			Remarks
		Indoor	Outdoor	Remote Controller	
0403	Serial communication error		○		Outdoor unit Multi controller board ~ Power board communication trouble
1102	Compressor temperature		○		Check delay code 1202
1300	Low pressure		○		
1302	High pressure		○		Check delay code 1402
1500	Superheat due to low discharge temperature		○		Check delay code 1600
1501	Refrigerant shortage		○		Check delay code 1601
	Closed valve in cooling mode		○		Check delay code 1501
1508	4-way valve trouble in heating mode		○		Check delay code 1608
2500	Water leakage	○			
2502	Drain over flow protection	○			
2503	Drain sensor abnormality	○			
4100	Compressor current interruption (locked compressor)		○		Check delay code 4350
4114	Fan motor error	○			
4210	Compressor overcurrent interruption		○		
4220	Undervoltage/overvoltage/PAM error/L1open phase/power synchronization signal error		○		Check delay code 4320
4230	Heat Sink temperature		○		Check delay code 4330
4250	Power module		○		Check delay code 4350
4400	Fan trouble		○		Check delay code 4500
5101	Air inlet thermistor (TH21) open/short	○			
	Compressor temperature thermistor (TH4) open/short		○		Check delay code 1202
5102	Liquid pipe temperature thermistor (TH22) open/short	○			
	Suction pipe temperature thermistor (TH6) open/short		○		Check delay code 1211
5103	Gas pipe temperature thermistor (TH23) open/short	○			
5105	Outdoor liquid pipe temperature thermistor (TH3) open/short		○		Check delay code 1205
5106	Ambient thermistor (TH7) open/short		○		Check delay code 1221
5109	HIC pipe temperature thermistor (TH2) open/short		○		Check delay code 1222
5110	Heat Sink temperature thermistor (TH8) open/short		○		Check delay code 1214
5201	High pressure sensor (63HS)		○		Check delay code 1402
5202	Low pressure sensor (63LS)		○		Check delay code 1400
5701	Contact failure of drain float switch	○			
6600	Duplex address error	○	○	○	Only M-NET Remote controller is detected.
6602	Transmission processor hardware error	○	○	○	Only M-NET Remote controller is detected.
6603	Transmission bus BUSY error	○	○	○	Only M-NET Remote controller is detected.
6606	Signal communication error with transmission processor	○	○	○	Only M-NET Remote controller is detected.
6607	No ACK error	○		○	Only M-NET Remote controller is detected. *
6608	No response frame error	○		○	Only M-NET Remote controller is detected. *
6831	MA communication receive error (no receive signal)	○		○	Only MA Remote controller is detected.
6832	MA communication send error	○		○	Only MA Remote controller is detected.
6833	MA communication send error	○		○	Only MA Remote controller is detected.
6834	MA communication receive error	○		○	Only MA Remote controller is detected.
7100	Total capacity error		○		
7101	Capacity code error	○	○		
7102	Connecting excessive number of units		○		
7105	Address setting error		○		

Note:

When the outdoor unit detects No ACK error/No response error, an object indoor unit is treated as a stop, and not assumed to be abnormal.

*Abnormality for PWFY series

8-2. HOW TO CHECK THE PARTS

PLFY-P05NFMU-E.TH

PLFY-P08NFMU-E.TH

PLFY-P12NFMU-E.TH

PLFY-P15NFMU-E.TH

PLFY-P18NFMU-E.TH

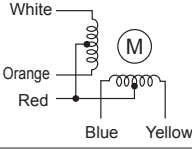
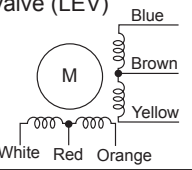
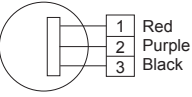
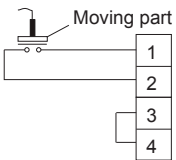
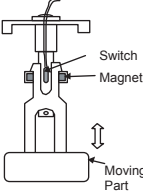
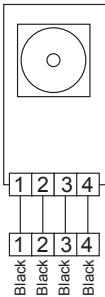
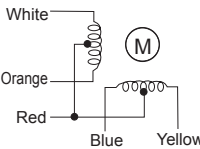
Parts name	Check points														
Thermistor (TH21) (Room temperature detection) Thermistor (TH22) (Pipe temperature detection/Liquid) Thermistor (TH23) (Pipe temperature detection/Gas)	Disconnect the connector then measure the resistance with a tester. (At the ambient temperature 10 to 30°C) <table border="1" style="margin-left: 20px;"> <thead> <tr> <th>Normal</th> <th>Abnormal</th> </tr> </thead> <tbody> <tr> <td>4.3 to 9.6 kΩ</td> <td>Open or short</td> </tr> </tbody> </table> Refer to "8-2-1. Thermistor Characteristic Graph".	Normal	Abnormal	4.3 to 9.6 kΩ	Open or short										
Normal	Abnormal														
4.3 to 9.6 kΩ	Open or short														
Vane motor (MV) 	Measure the resistance between the terminals with a tester. (At the ambient temperature 20 to 30°C) <table border="1" style="margin-left: 20px;"> <thead> <tr> <th colspan="4">Normal</th> <th>Abnormal</th> </tr> </thead> <tbody> <tr> <td>Red–Yellow</td> <td>Red–Blue</td> <td>Red–Orange</td> <td>Red–White</td> <td rowspan="2">Open or short</td> </tr> <tr> <td colspan="4" style="text-align: center;">300 Ω</td> </tr> </tbody> </table>	Normal				Abnormal	Red–Yellow	Red–Blue	Red–Orange	Red–White	Open or short	300 Ω			
Normal				Abnormal											
Red–Yellow	Red–Blue	Red–Orange	Red–White	Open or short											
300 Ω															
Linear expansion valve (LEV) 	Disconnect the connector then measure the valve resistance with a tester. <table border="1" style="margin-left: 20px;"> <thead> <tr> <th colspan="4">Normal</th> <th>Abnormal</th> </tr> </thead> <tbody> <tr> <td>White-Red</td> <td>Yellow-Brown</td> <td>Orange-Red</td> <td>Blue-Brown</td> <td rowspan="2">Open or short</td> </tr> <tr> <td colspan="4" style="text-align: center;">200Ω ±10%</td> </tr> </tbody> </table> Refer to "8-2-2. Linear Expansion Valve".	Normal				Abnormal	White-Red	Yellow-Brown	Orange-Red	Blue-Brown	Open or short	200Ω ±10%			
Normal				Abnormal											
White-Red	Yellow-Brown	Orange-Red	Blue-Brown	Open or short											
200Ω ±10%															
Drain pump (DP) 	<ol style="list-style-type: none"> ① Check if the drain float switch works properly. ② Check if the drain pump works and drains water properly in cooling operation. ③ If no water drains, confirm that the check code 2502 will not be displayed 10 minutes after the operation starts. Note: The drain pump for this model is driven by the control board and is a DC volt motor, so it is not possible to measure the resistance between the terminals. <p>Normal Red–Black: Input 13 V DC → The pump starts to rotate. Purple–Black: Abnormal (check code 2502) if it outputs 0–13 V square wave (5 pulses/rotation), and the number of rotation is not normal.</p>														
Drain float switch (FS) 	Measure the resistance between the terminals with a tester. <table border="1" style="margin-left: 20px;"> <thead> <tr> <th>State of moving part</th> <th>Normal</th> <th>Abnormal</th> </tr> </thead> <tbody> <tr> <td>UP</td> <td>Short</td> <td>Other than short</td> </tr> <tr> <td>DOWN</td> <td>Open</td> <td>Other than open</td> </tr> </tbody> </table> 	State of moving part	Normal	Abnormal	UP	Short	Other than short	DOWN	Open	Other than open					
State of moving part	Normal	Abnormal													
UP	Short	Other than short													
DOWN	Open	Other than open													
i-see sensor * 	Turn the power ON while the i-see sensor connector is connected to the CN4Z on indoor controller board. A communication between the indoor controller board and i-see sensor board is made to detect the connection. <p>Normal: When the operation starts, the motor for i-see sensor is driven to rotate the i-see sensor. Abnormal: The motor for i-see sensor is not driven when the operation starts.</p> Note: The voltage between the terminals cannot be measured accurately since it is pulse output.														
i-see sensor motor * 	Measure the resistance between the terminals with a tester. (At the ambient temperature 20 to 30°C) <table border="1" style="margin-left: 20px;"> <thead> <tr> <th colspan="4">Normal</th> <th>Abnormal</th> </tr> </thead> <tbody> <tr> <td>Red–Yellow</td> <td>Red–Blue</td> <td>Red–Orange</td> <td>Red–White</td> <td rowspan="2">Open or short</td> </tr> <tr> <td colspan="4" style="text-align: center;">250 Ω</td> </tr> </tbody> </table>	Normal				Abnormal	Red–Yellow	Red–Blue	Red–Orange	Red–White	Open or short	250 Ω			
Normal				Abnormal											
Red–Yellow	Red–Blue	Red–Orange	Red–White	Open or short											
250 Ω															

* i-see sensor is available with optional "i-see sensor corner panel" (SLP-18FAEU).

8-2-1. Thermistor Characteristic Graph

<Thermistor characteristic graph>

Thermistor for lower temperature

Room temperature detection thermistor (TH21)
 Pipe temperature detection thermistor/liquid (TH22)
 Pipe temperature detection thermistor/gas (TH23)

Thermistor $R_0=15\text{ k}\Omega \pm 3\%$
 Fixed number of $B=3480 \pm 2\%$

$$R_t = 15 \exp \left\{ 3480 \left(\frac{1}{273 + (t-32)/1.8} - \frac{1}{273} \right) \right\}$$

30°F	15.8 kΩ
50°F	9.6 kΩ
70°F	6.0 kΩ
80°F	4.8 kΩ
90°F	3.9 kΩ
100°F	3.2 kΩ

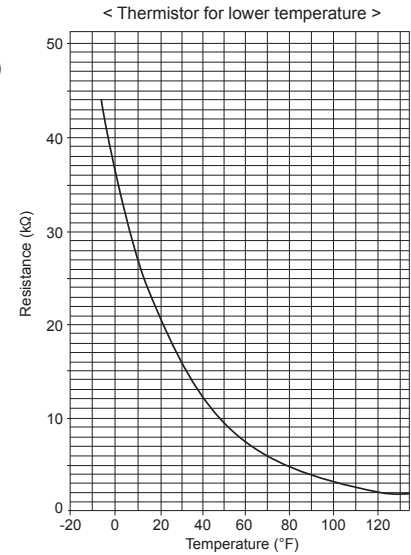

8-2-2. Linear Expansion Valve

① Operation summary of the linear expansion valve

- Linear expansion valves open/close through the use of a stepping motor after receiving the pulse signal from the indoor controller board.
- Valve position can be changed in proportion to the number of pulse signals.

<Connection between the indoor controller board and the linear expansion valve>

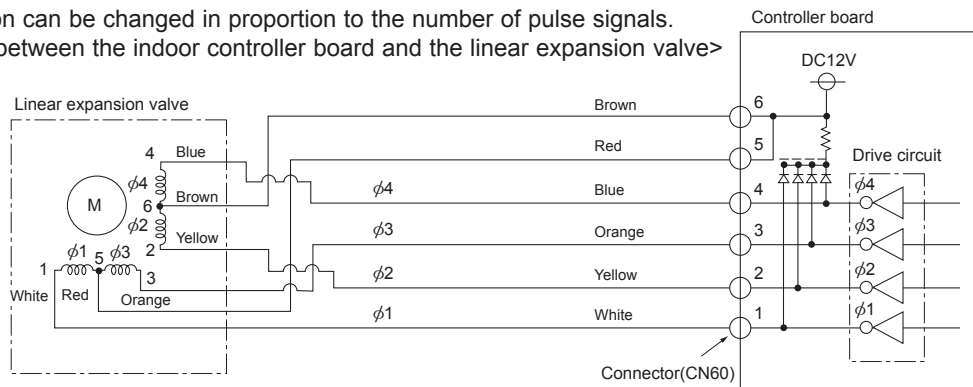

Note : Since the order of connector numbers is different at the controller board side from the LEV side, see the colors of lead wires to check the numbers.

<Output pulse signal and the valve operation>

Output (Phase)	Output			
	1	2	3	4
φ1	ON	OFF	OFF	ON
φ2	ON	ON	OFF	OFF
φ3	OFF	ON	ON	OFF
φ4	OFF	OFF	ON	ON

Closing a valve : 1 → 2 → 3 → 4 → 1
 Opening a valve : 4 → 3 → 2 → 1 → 4

The output pulse shifts in above order.

- When linear expansion valve operation stops, all output phases become OFF.
- At phase interruption or when phase does not shift in order, motor does not rotate smoothly and motor will lock and vibrate.
- When power is applied valve drives in the closed direction 2200 pulses and will end at ④. This is done to define valve position.
- When the valve moves smoothly, there is no sound or vibration occurring from the linear expansion valves : however, when the pulse number moves from ⑤ to ④ or when the valve is locked, more sound can be heard than in a normal situation.
- Sound can be detected by placing the ear against the screw driver handle while putting the screw driver tip to the linear expansion valve.

② Linear expansion valve operation

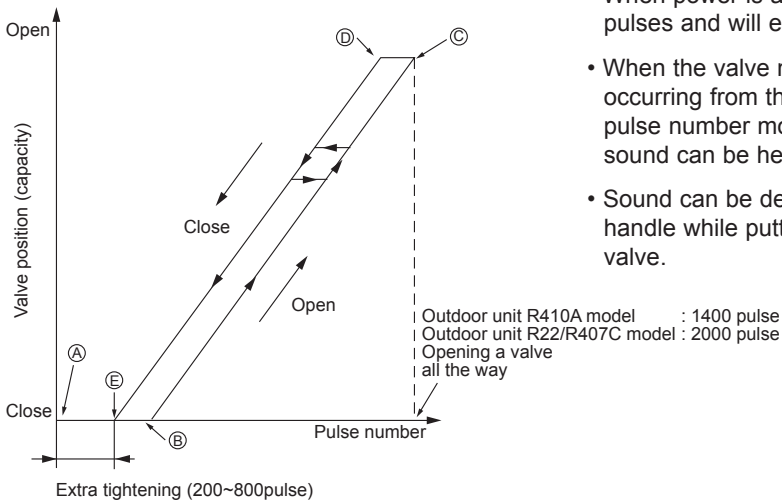

③ Troubleshooting

Symptom	Check points	Countermeasures
Operation circuit failure of the micro processor	Disconnect the connector on the controller board, then connect LED for checking. 1kΩ LED	Exchange the indoor controller board at drive circuit failure.
Linear expansion valve mechanism is locked.	Motor will idle and make a ticking noise when the motor is operated while the linear expansion valve is locked. This ticking sound is the sign of the abnormality.	Exchange the linear expansion valve.
Short or breakage of the motor coil of the linear expansion valve	Measure the resistance between each coil (white-red, yellow-brown, orange-red, blue-brown) with a tester. It is normal if the resistance is in the range of 200Ω ±10%.	Exchange the linear expansion valve.
Valve does not close completely.	To check the linear expansion valve, operate the indoor unit in fan mode and at the same time operate other indoor units in cooling mode, then check the pipe temperature <liquid pipe temperature> of the indoor unit by the outdoor multi controller board operation monitor. During fan operation, linear expansion valve is closed completely and if there is any leaking, detecting temperature of the thermistor will go lower. If the detected temperature is much lower than the temperature indicated in the remote controller, it means the valve is not closed all the way. Thermistor (Liquid pipe) Linear expansion valve	If large amount of refrigerant leaks, exchange the linear expansion valve.
Wrong connection of the connector or contact failure	Check the color of lead wire and missing terminal of the connector.	Disconnect the connector at the controller board, then check the continuity.

8-2-3. DC Fan Motor (Fan Motor/Indoor Controller Board)

Check method of indoor fan motor (fan motor/indoor controller board)

① Notes







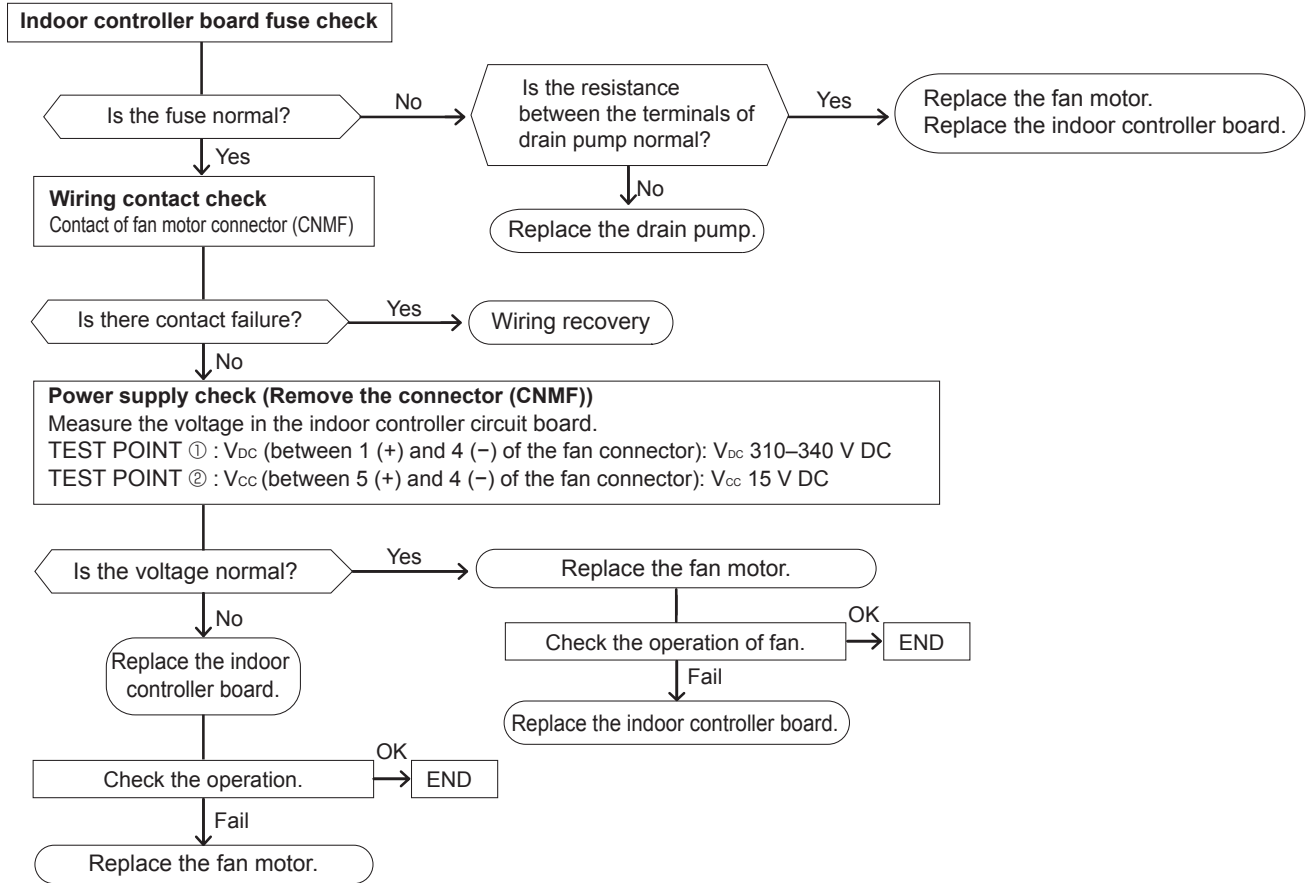



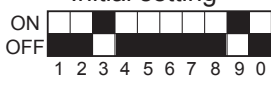







- High voltage is applied to the connector (CNMF) for the fan motor. Pay attention to the service.
- Do not pull out the connector (CNMF) for the motor with the power supply on.
(It will damage the indoor controller board and fan motor)

② Self check

Conditions : The indoor fan cannot turn around.

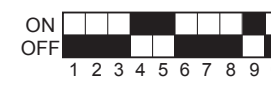
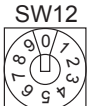
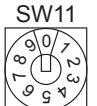
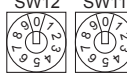
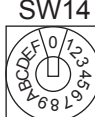

8-3. FUNCTION OF DIP SWITCH

Switch	Pole	Function	Operation by switch		Effective timing	Remarks																
			ON	OFF																		
SW1 Function Selection	1	Thermistor <Room temperature detection> position	Built-in remote controller	Indoor unit	Under suspension	<div style="border: 1px solid black; padding: 2px; display: inline-block;">Indoor controller board</div> <Initial setting> ON  OFF																
	2	Filter clogging detection	Provided	Not provided																		
	3	Filter cleaning	2,500h	100h																		
	4	Fresh air intake	Effective	Not effective																		
	5	Remote indication switching	Thermo ON signal indication	Fan output indication																		
	6	—	—	—																		
	7	Air flow set in case of Heat thermo OFF	Low *1	Extra low *1																		
	8	Auto restart function	Effective	Not effective																		
	9	Power ON/OFF	Effective	Not effective																		
	0	Power ON/OFF	Effective	Not effective																		
SW2 Capacity code setting	1-6	<table border="1" style="width: 100%; text-align: center;"> <tr> <td>Capacity</td> <td>SW 2</td> <td>Capacity</td> <td>SW 2</td> <td>Capacity</td> <td>SW 2</td> </tr> <tr> <td>P05</td> <td>ON OFF </td> <td>P12</td> <td>ON OFF </td> <td>P18</td> <td>ON OFF </td> </tr> <tr> <td>P08</td> <td>ON OFF </td> <td>P15</td> <td>ON OFF </td> <td></td> <td></td> </tr> </table>	Capacity	SW 2	Capacity	SW 2	Capacity	SW 2	P05	ON OFF 	P12	ON OFF 	P18	ON OFF 	P08	ON OFF 	P15	ON OFF 			Before power supply ON	<div style="border: 1px solid black; padding: 2px; display: inline-block;">Indoor controller board</div> <Initial setting> Set for each capacity.
		Capacity	SW 2	Capacity	SW 2	Capacity	SW 2															
P05	ON OFF 	P12	ON OFF 	P18	ON OFF 																	
P08	ON OFF 	P15	ON OFF 																			
1	Heat pump/Cooling only	Cooling only	Heat pump	Under suspension	<div style="border: 1px solid black; padding: 2px; display: inline-block;">Indoor controller board</div> <Initial setting> Set for each capacity. ON  OFF																	
2	—	—	—																			
3	—	—	—																			
4	Setting i-See sensor installation position	Setting pattern ③	Setting pattern ①																			
5	Vane horizontal angle	Second setting	First setting																			
6	—	—	—																			
7	Indoor linear expansion valve opening	Effective	Not effective																			
8	Heat 4 degrees up	Not effective	Effective																			
9	—	—	—																			
0	—	—	—																			
SW11 1s digit address setting SW12 10s digit address setting	Rotary switch	  10 1	Address setting should be done when M-NET remote controller is being used.	Before power supply ON	<div style="border: 1px solid black; padding: 2px; display: inline-block;">Indoor controller board</div> <Initial setting> SW12 SW11 																	
SW14 Branch No. setting	Rotary switch		This is the switch to be used when the indoor unit is operated with R2 series outdoor unit as a set. With other than R2 series outdoor unit leave at 0.	Before power supply ON	<div style="border: 1px solid black; padding: 2px; display: inline-block;">Indoor controller board</div> <Initial setting> SW14 																	

*1 Refer to the <Table A> below.





<Table A>

SW1-7	SW1-8	
OFF	OFF	Extra low
ON	OFF	Low
OFF	ON	Setting air flow
ON	ON	stop

Continue to the next page

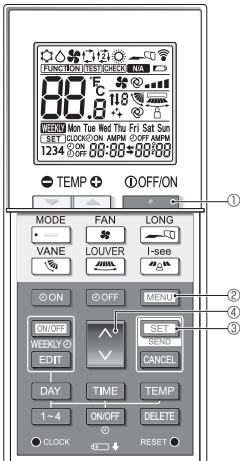
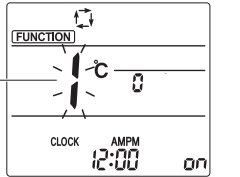
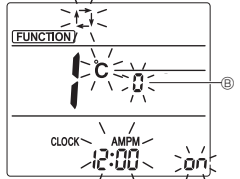
Switch	Pole	Function	Operation by switch		Effective timing	Remarks												
			ON	OFF														
SW21 Function selection	1	Setting ceiling height	Depends on SW21-1, SW21-2		Under operation or suspension	<Initial setting> ON <table border="1" style="display: inline-table; vertical-align: middle;"><tr><td> </td><td> </td><td> </td><td> </td><td> </td><td> </td></tr></table> OFF <table border="1" style="display: inline-table; vertical-align: middle;"><tr><td> </td><td> </td><td> </td><td> </td><td> </td><td> </td></tr></table>												
	2																	
	3	—	—															
	4	—	—															
5	—	—																
6	—	—																

	SW21-1	SW21-2	Height
Silent	—	ON	8.2 ft [2.5 m]
Standard	OFF	OFF	8.9 ft [2.7 m] (default setting)
High	ON	OFF	9.8 ft [3.0 m]

Switch	Pole	Function	Operation by switch		Effective timing	Remarks																																										
			ON	OFF																																												
SW22 Function selection	Jumper	<table border="1"> <thead> <tr> <th>Function</th> <th>ON</th> <th>OFF</th> </tr> </thead> <tbody> <tr> <td>1</td> <td>—</td> <td>—</td> </tr> <tr> <td>2</td> <td>—</td> <td>—</td> </tr> <tr> <td>3 Pair No. of wireless remote controller</td> <td colspan="2" rowspan="2">Depends on SW22-3, 22-4</td> </tr> <tr> <td>4 Pair No. of wireless remote controller</td> </tr> </tbody> </table> <ul style="list-style-type: none"> To operate each indoor unit by each remote controller when installed 2 indoor units or more are near, Pair No. setting is necessary. <ul style="list-style-type: none"> Pair No. setting is available with the 4 patterns (Setting patterns A to D). Make setting for J41, J42 of indoor controller board and the Pair No. of wireless remote controller. You may not set it when operating it by one remote controller. <ul style="list-style-type: none"> Setting for indoor unit Cut jumper wire J41, J42 on the indoor controller board according to the table below. <p>Wireless remote controller pair number:</p> <ul style="list-style-type: none"> Setting operation (Fig. 1 ①) <ol style="list-style-type: none"> Press the ON/OFF button ① to stop the air conditioner. Press the MENU button ②. Check that function No."1" is displayed, and then press the SET button ③. The Screen display setting screen will be displayed. (Fig. 2.) Pair No. changing operation (Fig. 2 ②) <ol style="list-style-type: none"> Press the ON/OFF button ④. Each time the ON/OFF button ④ is pressed, the pair No.0-3 changes. Press the SET button ③ to check the setting. Press the MENU button ②. <table border="1"> <thead> <tr> <th colspan="2">Indoor unit SW22</th> <th colspan="2">Pair No. of wireless remote controller</th> <th></th> </tr> <tr> <th>SW22-3</th> <th>SW22-4</th> <th></th> <th></th> <th></th> </tr> </thead> <tbody> <tr> <td>ON</td> <td>ON</td> <td>0</td> <td></td> <td>Initial setting</td> </tr> <tr> <td>OFF</td> <td>ON</td> <td>1</td> <td></td> <td>—</td> </tr> <tr> <td>ON</td> <td>OFF</td> <td>2</td> <td></td> <td>—</td> </tr> <tr> <td>OFF</td> <td>OFF</td> <td>3-9</td> <td></td> <td>—</td> </tr> </tbody> </table>	Function	ON	OFF	1	—	—	2	—	—	3 Pair No. of wireless remote controller	Depends on SW22-3, 22-4		4 Pair No. of wireless remote controller	Indoor unit SW22		Pair No. of wireless remote controller			SW22-3	SW22-4				ON	ON	0		Initial setting	OFF	ON	1		—	ON	OFF	2		—	OFF	OFF	3-9		—	Depends on SW22-3, 22-4	Under operation or suspension	<Initial setting>   
		Function	ON	OFF																																												
1	—	—																																														
2	—	—																																														
3 Pair No. of wireless remote controller	Depends on SW22-3, 22-4																																															
4 Pair No. of wireless remote controller																																																
Indoor unit SW22		Pair No. of wireless remote controller																																														
SW22-3	SW22-4																																															
ON	ON	0		Initial setting																																												
OFF	ON	1		—																																												
ON	OFF	2		—																																												
OFF	OFF	3-9		—																																												
SWE Test run for Drain pump	Connector	<p>Drain pump and fan are activated simultaneously after the connector SWE is set to ON and turn on the power.</p> <div style="display: flex; justify-content: space-around; align-items: center;"> <div style="text-align: center;"> <p>SWE</p>  OFF ON </div> <div style="font-size: 2em;">→</div> <div style="text-align: center;"> <p>SWE</p>  OFF ON </div> </div> <p>The connector SWE is set to OFF after test run.</p>		Under operation	<Initial setting> SWE  OFF ON																																											

8-4. TEST POINT DIAGRAM

Indoor controller board

PLFY-P05NFMU-E.TH

PLFY-P15NFMU-E.TH

PLFY-P08NFMU-E.TH

PLFY-P18NFMU-E.TH

PLFY-P12NFMU-E.TH

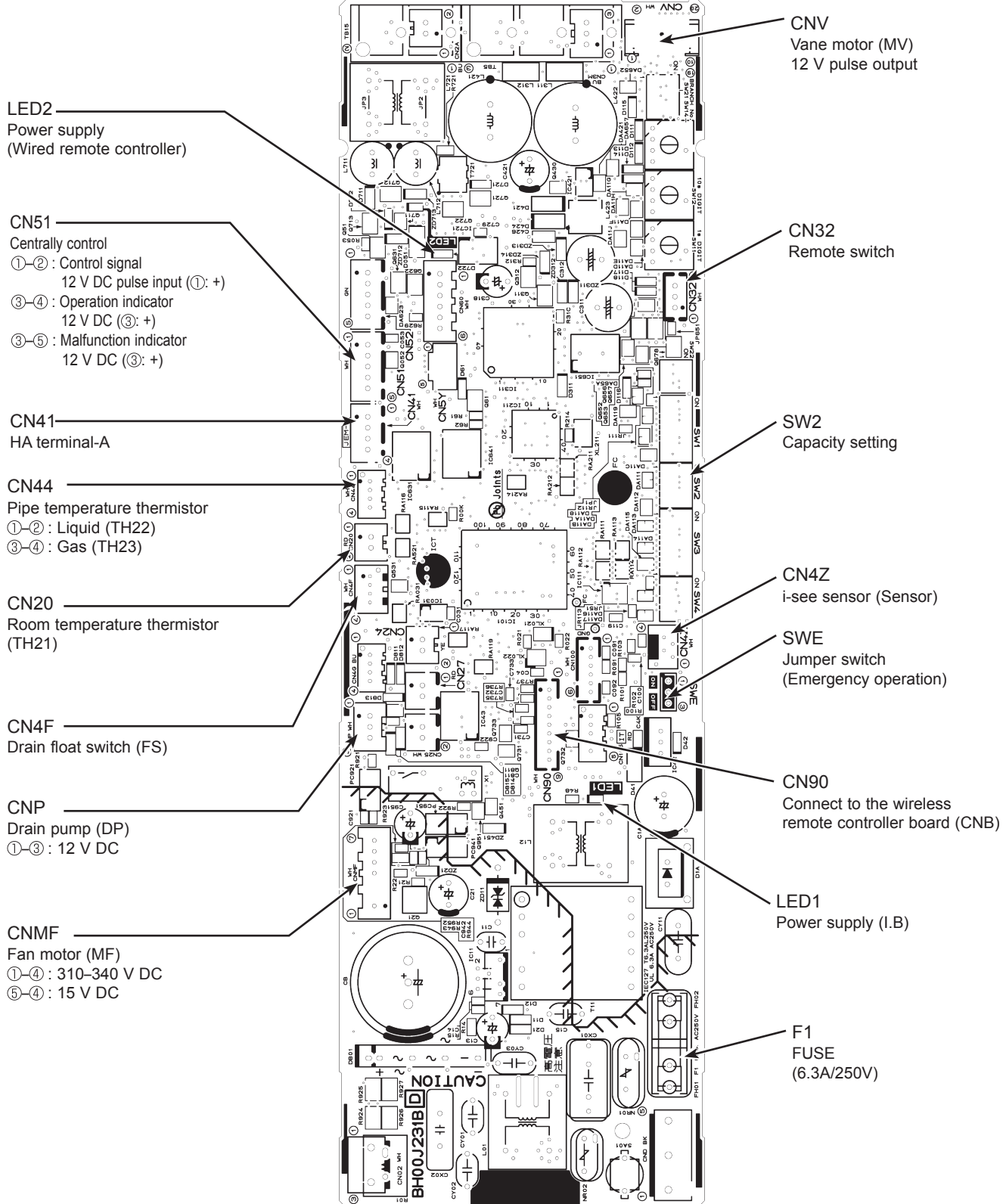

Note: The voltage range of 12 V DC in this page is between 11.5 to 13.7 V DC.

PLFY-P05NFMU-E.TH
PLFY-P15NFMU-E.TH

PLFY-P08NFMU-E.TH
PLFY-P18NFMU-E.TH

PLFY-P12NFMU-E.TH

Be careful when removing heavy parts.

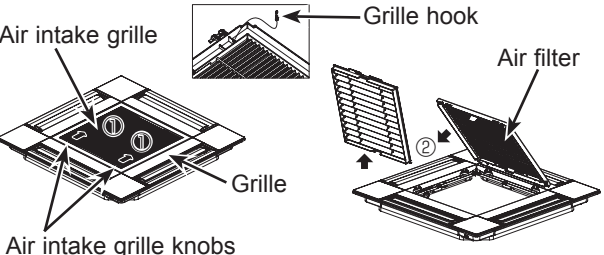
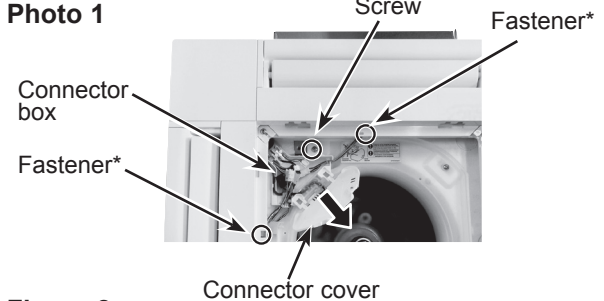
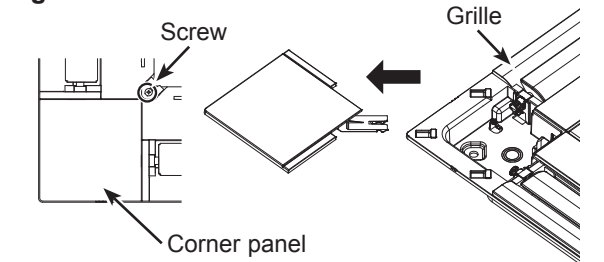
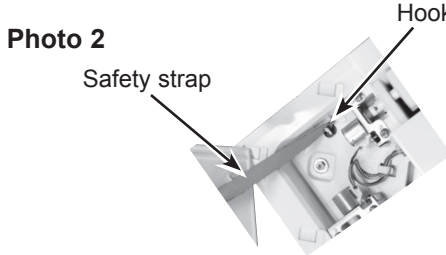
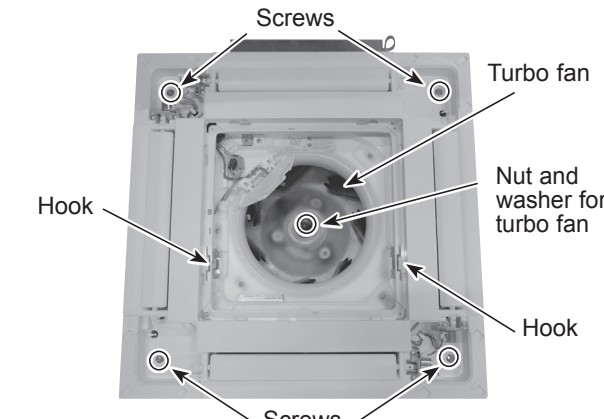
OPERATING PROCEDURE	PHOTOS & ILLUSTRATIONS
<p>1. Removing the air intake grille and air filter</p> <p>(1) Slide the knob of air intake grille to the direction of the arrow ① to open the air intake grille.</p> <p>(2) Remove the grille hook from the panel to prevent the grille from dropping.</p> <p>(3) Slide the hinge of the intake grille to the direction of the arrow ② and remove the air filter.</p>	<p>Figure 1</p>  <p>Air intake grille Grille hook Air filter Grille Air intake grille knobs</p>
<p>2. Removing the panel</p> <p>(1) Remove the air intake grille. (Refer to procedure 1)</p> <p>Connector box (See Photo 1)</p> <p>(2) Remove the screw of the connector cover.</p> <p>(3) Slide the connector cover to the direction of the arrow to open the cover.</p> <p>(4) Disconnect all the connectors, then pull out the connectors that are coming from panel side from the connector box.</p> <p>Corner panel (See Figure 2 and Photo 2)</p> <p>(5) Loosen the screw from the corner of the corner panel.</p> <p>(6) Slide the corner panel as indicated by the arrow.</p> <p>(7) Remove the safety strap from the hook, then remove the corner panel from the panel. (The safety strap is not equipped for the signal receiver panel and i-See sensor corner panel.)</p> <p>(8) Remove the fastener (*), then remove the corner panel.</p> <p>Panel (See Photo 3)</p> <p>(9) Remove the 4 screws.</p> <p>(10) Unlatch the 2 hooks.</p> <p>* Fastener is only for the signal receiver and i-See sensor corner panel.</p>	<p>Photo 1</p>  <p>Screw Fastener* Connector box Fastener* Connector cover</p> <p>Figure 2</p>  <p>Screw Grille Corner panel</p> <p>Photo 2</p>  <p>Hook Safety strap</p> <p>Photo 3</p>  <p>Screws Turbo fan Nut and washer for turbo fan Hook Hook Screws</p>

OPERATING PROCEDURE

3. Removing the electrical parts

- (1) Loosen the 2 screws on the control box cover.
- (2) Slide the control box cover as indicated by the arrow to remove.

<Electrical parts in the control box>

- Indoor controller board (I.B)
- Terminal block (TB2)
- Terminal block (TB5)
- Terminal block (TB15)

PHOTOS

Photo 4

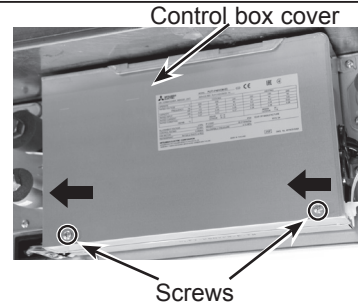

Photo 5

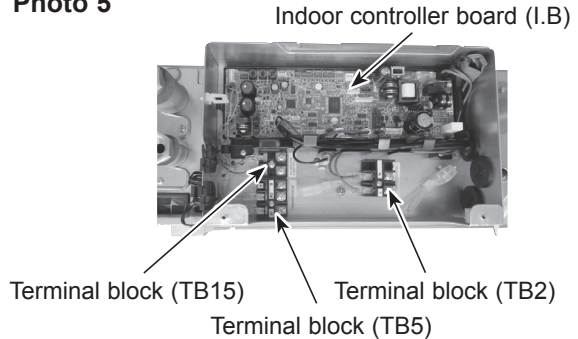
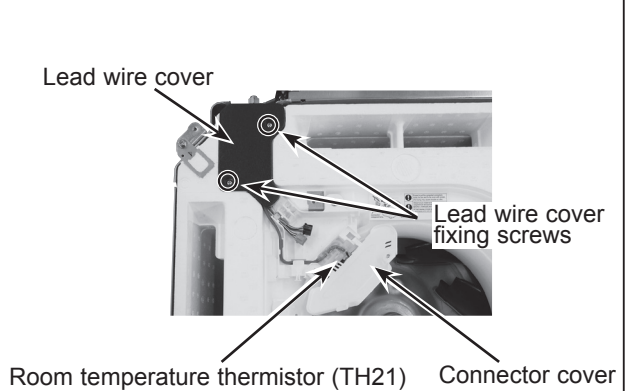

Photo 6



4. Removing the room temperature thermistor (TH21)

- (1) Remove the panel. (Refer to procedure 2)

Room temperature thermistor (TH21) (See Photo 6)

- (2) Remove the 2 lead wire cover fixing screws. (See Photo 6)
- (3) Open the lead wire cover, then remove the connector cover from the connector box.
- (4) Remove the band that fixes the room temperature thermistor (TH21) to the connector box.
- (5) Remove the room temperature thermistor (TH21) from the connector box.
- (6) Remove the connector (CN20) from the indoor controller board, and disconnect the room temperature thermistor (TH21).

Note: When fixing the thermistor, make sure to fix it to the connector box using a band.

Photo 7

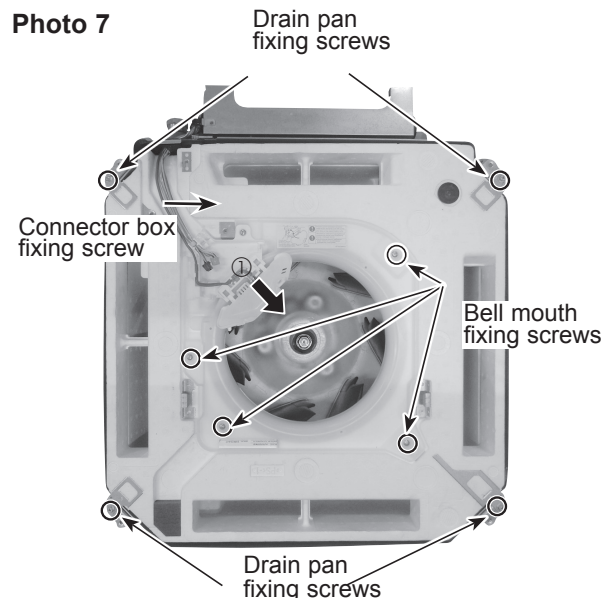

5. Removing the drain pan

- (1) Remove the panel. (Refer to procedure 2)
- (2) Remove the room temperature thermistor (TH21). (Refer to procedure 4)

Connector box (See Photo 7)

- (3) Remove the connector box fixing screw.
- (4) Slide the connector box as indicated by the arrow ①, then remove the claw from bell mouth.

Bell mouth (See Photo 7)

- (5) Remove the 4 bell mouth fixing screws, then remove the bell mouth.

Drain pan (See Photo 7)

- (6) Remove the 4 drain pan fixing screws, then remove the drain pan.

OPERATING PROCEDURE

6. Removing the pipe temperature thermistor/liquid (TH22) and pipe temperature thermistor/gas (TH23)

- (1) Remove the panel. (Refer to procedure 2)
- (2) Remove the room temperature thermistor (TH21). (Refer to procedure 4)
- (3) Remove the drain pan. (Refer to procedure 5)

Pipe temperature thermistor/liquid (TH22) and pipe temperature thermistor/gas (TH23) (See Photo 8)

- (4) Remove the control box cover. (Refer to procedure 3)
- (5) Disconnect the thermistor connectors from the CN44 on the indoor controller board.
- (6) Cut the band fixing the thermistor connectors to the fan motor cable.
- (7) Remove the thermistors from the holders on heat exchanger.

Note:

When re-attaching the thermistor connectors to the fan motor cable, make sure to put the fixed band into the groove. (See Photo 8-1)

PHOTOS

Photo 8 Pipe temperature thermistor/Gas (TH23) Band Fan motor cable

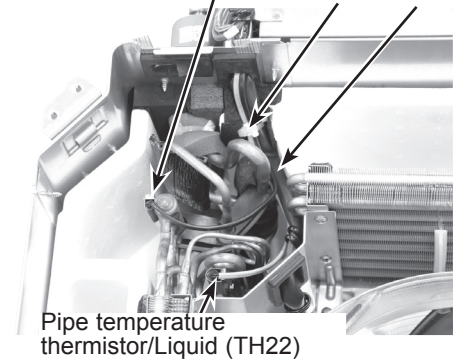
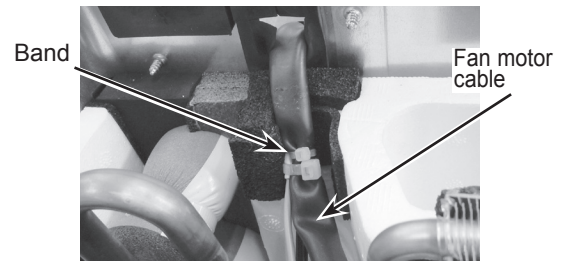

Photo 8-1



7. Removing the fan motor (MF)

- (1) Remove the panel. (Refer to procedure 2)
- (2) Remove the room temperature thermistor (TH21). (Refer to procedure 4)
- (3) Remove the drain pan. (Refer to procedure 5)

Turbo fan (See Photo 3)

- (4) Remove the nut and washer from the turbo fan.
- (5) Remove the turbo fan from the motor shaft.

Notes:

- When assembling, make sure that the protrusions on the turbo fan fit into the holes on the washer.
- Tightening torque for the nut: 4.5 ± 0.5 Nm

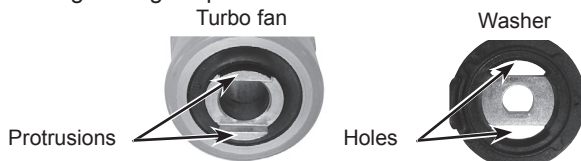

Fan motor (See Photo 9)

- (6) Remove the control box cover. (Refer to procedure 3)
- (7) Disconnect the fan motor cable from the CNMF on the indoor controller board.
- (8) Remove the 2 motor lead cover fixing screws, then remove the motor lead cover.
- (9) Loosen the 3 clamps fixing the fan motor cable.
- (10) Cut the band.
- (11) Remove the 3 nuts and washers, then remove the fan motor.
- (12) Remove the 3 motor mounts.

Notes:

1. When re-attaching the motor mount, make sure that the thicker end faces the motor shaft. (See Photo 10-1)
2. When re-attaching the turbo fan, make sure that the tightening torque for nuts is 5 N·m or lower.

Photo 9

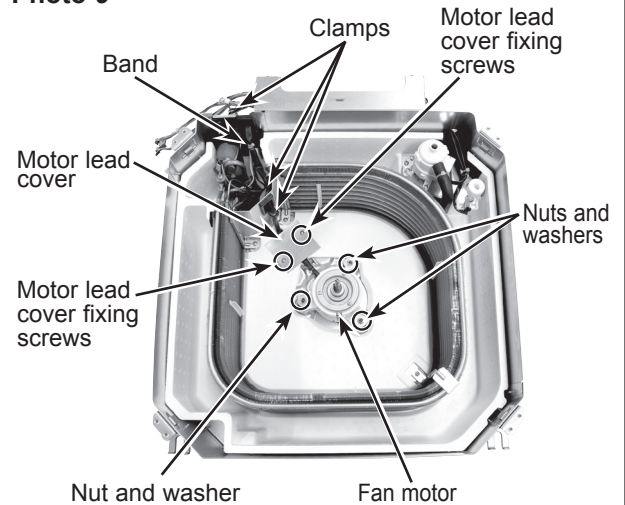
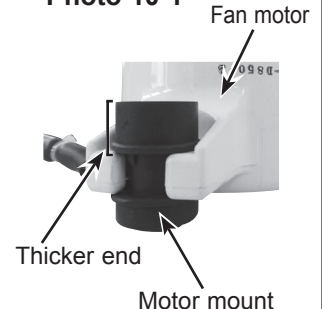

Photo 10



Photo 10-1



OPERATING PROCEDURE

8. Removing the drain pump (DP) and float switch (FS)

- (1) Remove the panel. (Refer to procedure 2)
- (2) Remove the room temperature thermistor (TH21). (Refer to procedure 4)
- (3) Remove the control box cover. (Refer to procedure 3)
- (4) Remove the drain pan. (Refer to procedure 5)

Drain pump (See Photo 11 and 12)

- (5) Disconnect the drain pump connector from the CNP and float switch connector from CN4F on the indoor controller board.
- (6) Loosen the clamp fixing the connectors on the side of the control box.
- (7) Cut the hose band and release the hose.
- (8) Remove the 2 screws fixing the drain pump and float switch to the inner cover.
- (9) Slide the base plate of the drain pump and float switch as indicated by the arrow ① to remove.
- (10) Cut the band. (See Photo 12)
- (11) Remove the 3 drain pump fixing screws, then remove the drain pump. (See Photo 12)

Notes:

1. When re-attaching the drain pump, make sure to use a band to fix the connector to the base plate.
2. Do not give a shock to the float switch. Otherwise it can cause damage or malfunction.

PHOTOS

Photo 11

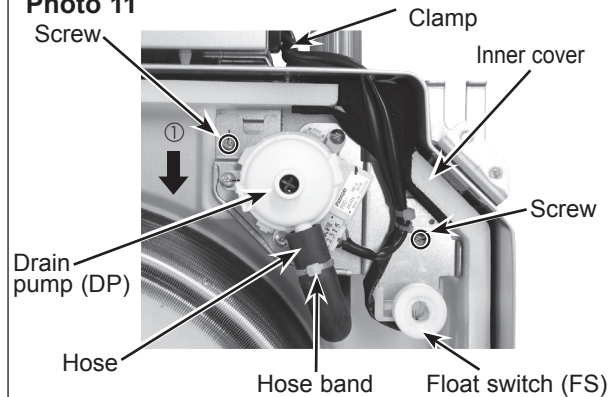
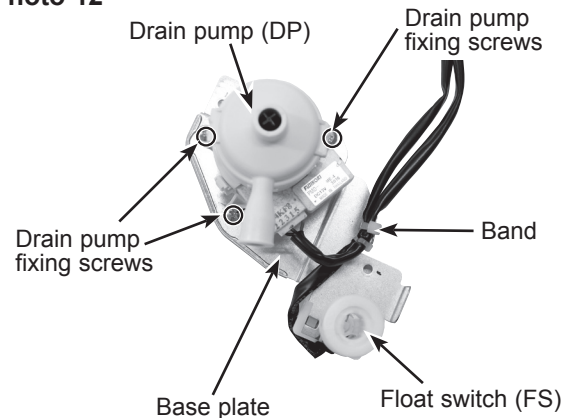

Photo 12



9. Removing the heat exchanger

- (1) Remove the panel. (Refer to procedure 2)
- (2) Remove the room temperature thermistor (TH21). (Refer to procedure 4)
- (3) Remove the drain pan. (Refer to procedure 5)
- (4) Remove the turbo fan and fan motor. (Refer to procedure 7)

Heat exchanger (See Photo 13 and 14)

- (5) Remove the 3 pipe cover fixing screws to remove the pipe cover.
- (6) Remove the 2 coil plate fixing screws.
- (7) Remove the coil support fixing screw, then remove the coil support.
- (8) Remove the heat exchanger.

Photo 13

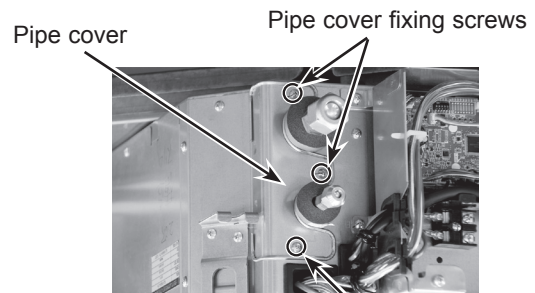
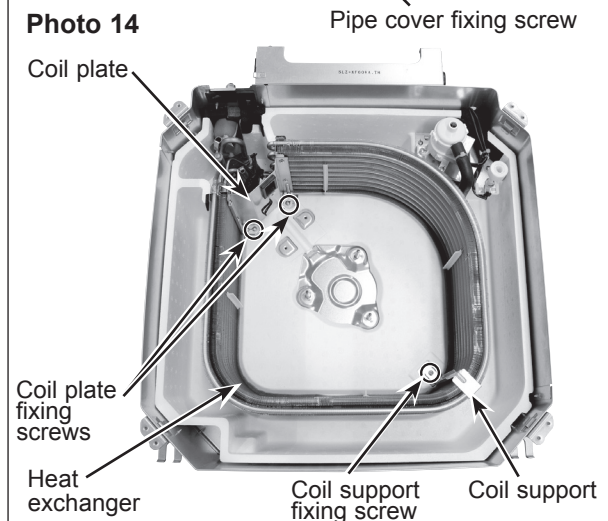

Photo 14



CITY MULTI

MITSUBISHI ELECTRIC CORPORATION

HEAD OFFICE : TOKYO BUILDING, 2-7-3, MARUNOUCHI, CHIYODA-KU TOKYO 100-8310, JAPAN
