



**G32MS  
CONVECTION OVEN**

**SERVICE MANUAL**





 **WARNING: ALL INSTALLATION AND SERVICE REPAIR WORK MUST BE CARRIED OUT BY QUALIFIED PERSONS ONLY.**



# CONTENTS

This manual is designed to take a more in depth look at the G32M and G32MS convection ovens for the purpose of making the units more understandable to service people.

There are settings explained in this manual that should never require to be adjusted, but for completeness and those special cases where these settings are required to change, this manual gives a full explanation as to how, and what effects will result.

SECTION	PAGE NO.
1. SPECIFICATIONS.....	5
2. INSTALLATION .....	8
3. OPERATION .....	11
3.1 Description of Controls	
3.2 Explanation of Control System	
4. MAINTENANCE.....	15
4.1 Cleaning	
4.2 Routine Procedures	
5. TROUBLE SHOOTING GUIDE .....	17
6. SERVICE PROCEDURES.....	22
6.1 Fault Diagnosis	
6.2 Access	
6.3 Replacement	
6.4 Adjustment / Calibration	
7. CIRCUIT SCHEMATICS.....	43
7.1 220-240V (United Kingdom Only)	
7.2 100-120V 60Hz (USA, Canada)	
7.3 220-240V (Not United Kingdom)	
8. ELECTRICAL WIRING DIAGRAMS .....	46
8.1 220-240V (United Kingdom Only)	
8.2 100-120V (USA, Canada)	
8.3 220-240V (Not United Kingdom)	
9. SPARE PARTS.....	49



**IMPORTANT:** MAKING ALTERATIONS MAY VOID WARRANTIES AND APPROVALS.

---



<b>10. ACCESSORIES / OPTIONS.....</b>	<b>51</b>
<b>11. PARTS DIAGRAM .....</b>	<b>52</b>
11.1 Main Assembly	
11.2 Control Panel Assembly	
11.3 Gas Assembly	
11.4 Gear Plate Assembly	
11.5 Door Assembly	
<b>12. SERVICE CONTACTS.....</b>	<b>63</b>
<b>APPENDIX A. Ignition Box Specifications .....</b>	<b>65</b>
<b>APPENDIX B. Double Stacking Kit (Kits manufactured from March 2004).....</b>	<b>66</b>
<b>APPENDIX C. Double Stacking Kit (Kits manufactured before March 2004).....</b>	<b>68</b>
<b>APPENDIX D. Motor Replacement Kit.....</b>	<b>68</b>

# 1. SPECIFICATIONS

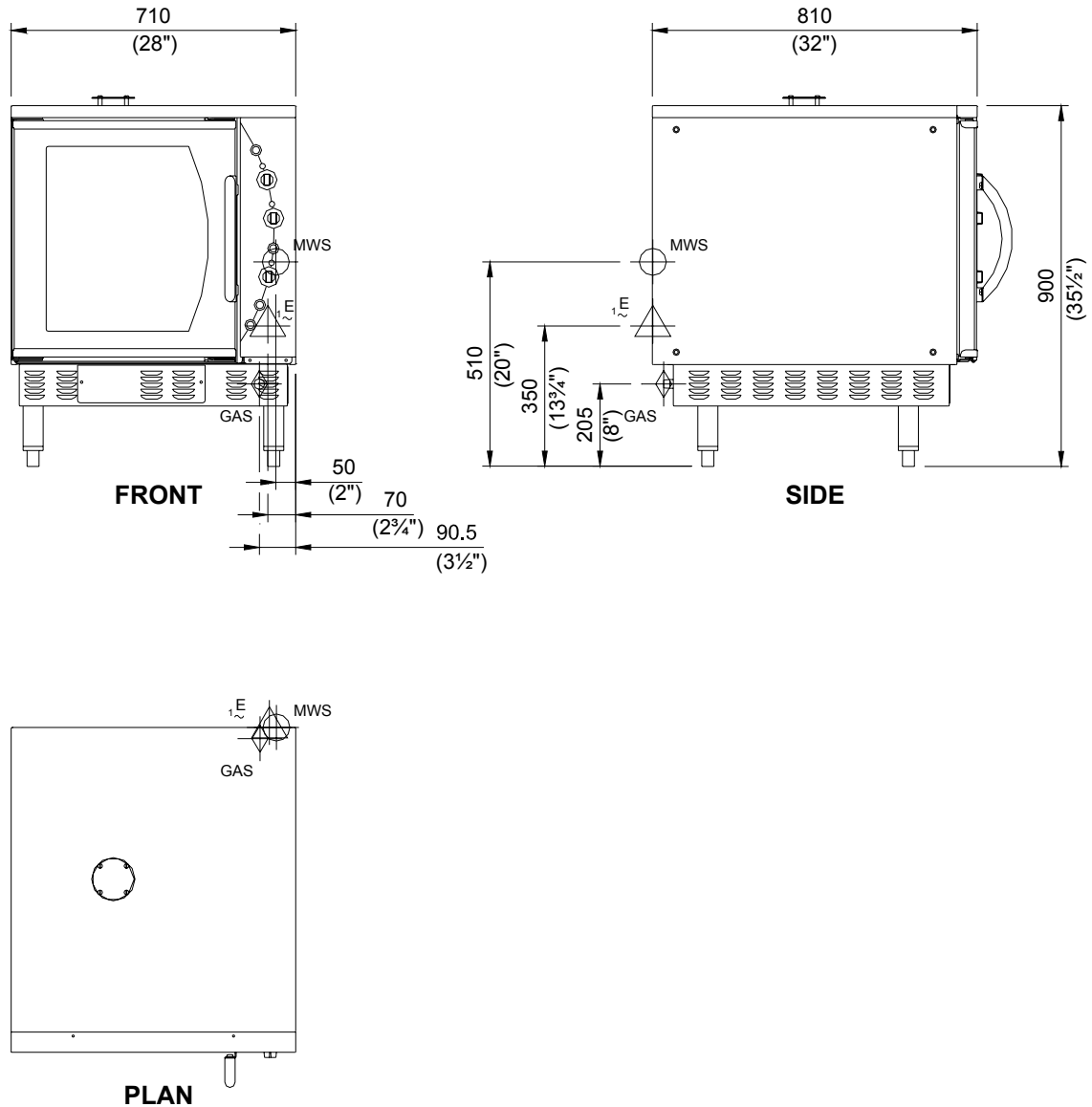
## MODEL: G32M



### LEGEND



- 
 - Electrical connection entry point
- 
 - Water entry - 3/4" BSP hose connection
- 
 - Gas connection entry point - 1/2" BSP female (not USA / Canada)  
 - 1/2" NPT female (USA / Canada only)

Dimensions shown in millimetres.  
 Dimensions in inches shown in brackets.

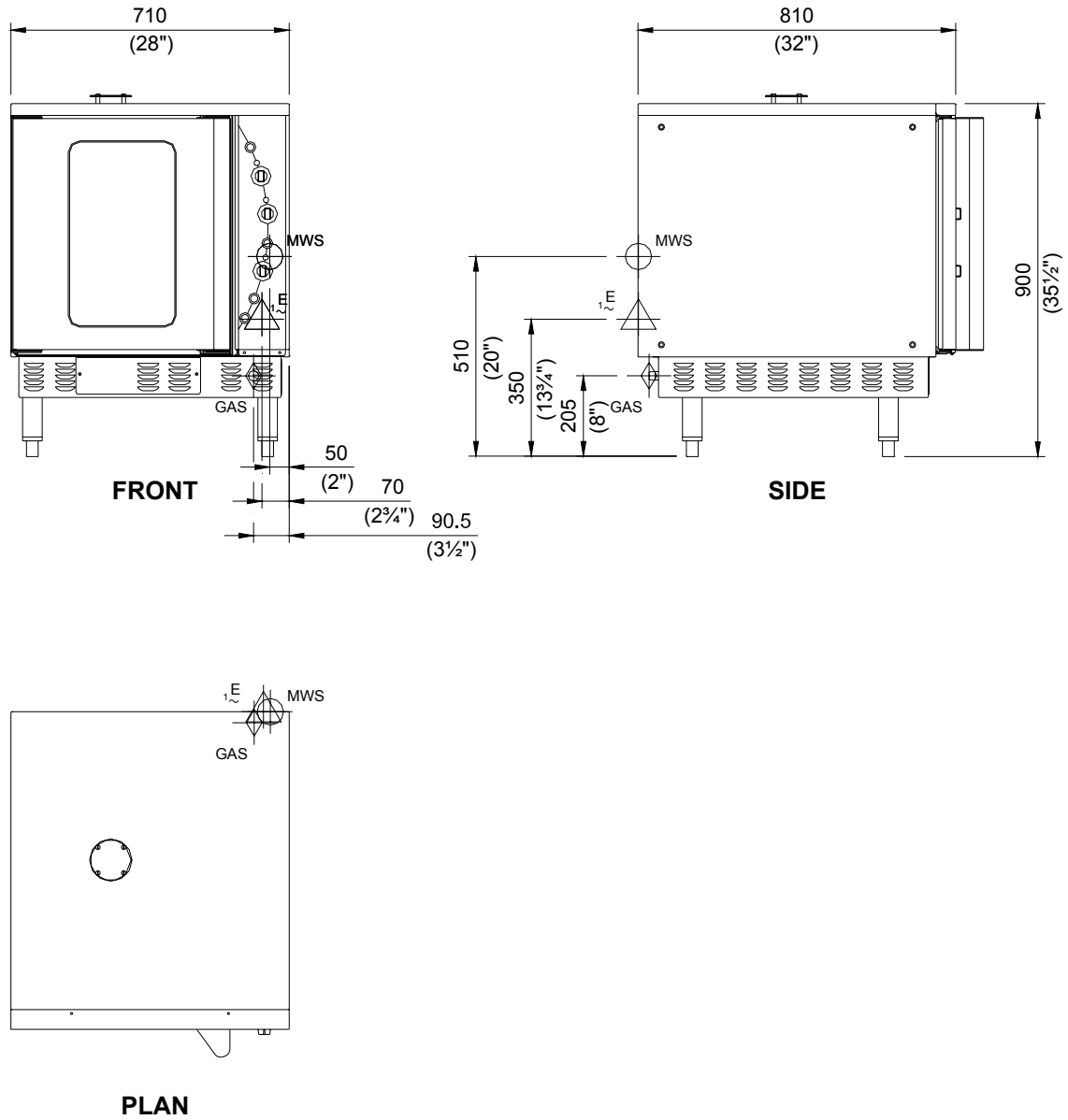
**MODEL: G32MS**



**LEGEND**

- 
- Electrical connection entry point
- 
- Water entry - 3/4" BSP hose connection
- 
- Gas connection entry point
  - 1/2" BSP female (not USA / Canada)
  - 1/2" NPT female (USA / Canada only)

Dimensions shown in millimetres.  
 Dimensions in inches shown in brackets.

## GAS SUPPLY REQUIREMENTS

	Natural Gas	LPG	Natural Gas - UK (G20)	Propane - UK (G31)
Input Rating (N.H.G.C.)	35 MJ/hr (33,000 Btu/hr)	35 MJ/hr (33,000 Btu/hr)	9.5 kW (0.91 m <sup>3</sup> /hr)	9.5 kW (0.67 kg/hr)
Injector Size	Ø2.80 mm (no. 35 drill size)	Ø1.80 mm (no. 50 drill size)	Ø2.60 mm	Ø1.55 mm
Supply Pressure	1.13 kPa (4½" w.c.)	2.75 kPa (11" w.c.)	20 mbar	37 mbar
Operating Pressure	0.85 kPa (3.5" w.c.)	2.25 kPa (9.0" w.c.)	10 mbar	35 mbar
Gas Connection	½" BSP Female		½" BSP Female	
	½" NPT Female (USA/Canada only)			

### LOCATION

This oven must be installed in an area of adequate air supply. The following minimum clearances for air openings, servicing, operation and installation are to be adhered to:

Rear	75mm / 3"
Left-hand side	75mm / 3"
Right-hand side*	75mm / 3"
Top	200mm / 8" (or 600mm from a combustible surface)
Floor	127mm / 5"

\* Fixed installations require at least 500mm (20") clearance at the right hand side for service accessibility.

### OVEN INTERNAL DIMENSIONS

Width	468 mm / 18.5"
Height	533 mm / 21"
Depth	711 mm / 28"
Oven Volume	0.18 m <sup>3</sup> / 6.3 ft <sup>3</sup>

### OVEN RACK SIZE

Width	460 mm / 18"
Depth:	660 mm / 26"

### ELECTRICAL SUPPLY SPECIFICATION OPTIONS

110-120 V AC, 60 Hz, 2.0 A, 1 Phase  
 220-240 V AC, 50 Hz, 0.7 A, 1 Phase  
 220-240 V AC, 60 Hz, 0.7 A, 1 Phase

### ELECTRICAL PLUG SPECIFICATION REQUIREMENTS

Australia	AS 2124, 10 Amp, 3 pin
Canada	NEMA 5-15, 15 Amp, 3 pin
New Zealand	AS 2124, 10 Amp, 3 pin
United Kingdom	BS 1363A 13A fused, 3 pin
United States	NEMA 5-15, 15 Amp, 3 pin
Other Countries	Type to meet country standards

### WATER SUPPLY CONNECTION

Max Pressure	550 kPa / 5.5 bar / 80 psi
Min Pressure	100 kPa / 1.0 bar / 15 psi

### AUTOMATIC IGNITION CONTROL

#### 110 Volt Models (24 Volt ignition system)

2 re-ignition attempts after burner ignition failure. 30 second purge time between ignition attempts. Lock-out condition after 3 ignition failures.

2 re-ignition attempts in the event of flame loss during burner operation. 30 second purge time between ignition attempts. Lock-out condition after 2 re-ignition attempt failures.

#### 220-240 Volt Models

Lock-out condition after burner ignition failure. No re-ignition attempt.

1 re-ignition attempt in the event of flame loss during burner operation. Lock-out condition if re-ignition failure.

**NOTE:** Refer to Appendix A for further ignition control specifications.

## 2. INSTALLATION

 **WARNING: THIS APPLIANCE MUST BE GROUNDED.**

 **WARNING: ALL INSTALLATION AND SERVICE REPAIR WORK MUST BE CARRIED OUT BY QUALIFIED PERSONS ONLY.**

This appliance must be installed in accordance with National installation codes and in addition, in accordance with relevant National / Local codes covering gas and fire safety.

### UNITED KINGDOM

GAS SAFETY (Installation & Use)  
- REGULATIONS 1984 Amendment 1990)

### AUSTRALIA

AS5601 / AG601 - 2000, Gas Installations

### NEW ZEALAND

NZS5261, Installation of Burning  
Appliances and Equipment

### UNITED STATES

ANSI 223.1 (Latest edition) National Gas  
Fuel Code

### CANADA

CAN/CGA -B149, Installation Codes for  
Gas Burning Appliances and Equipment

Installations must be carried out by authorised persons only. Failure to install equipment to relevant codes and manufacturers specifications in this section will void warranty.

The oven and its individual shutoff valve must be disconnected from the gas supply piping system during any pressure testing of that system at test pressures in excess of 0.5 psi (3.45 kPa / 34.5 mbar).

This oven must be electrically grounded in accordance with local codes.

### Before Connection to the Power and Gas Supplies

- Remove all packing.
- Check equipment and parts for damage. Report any damage immediately to the carrier and distributor.
- Remove protective plastic coating from the side panels.
- Check that the following parts have been supplied with your oven:
  - 4 x Leg assembly
  - 4 x Oven racks
  - 1 x Water inlet elbow (c/w washer)

- Report any deficiencies to the distributor who supplied the oven.
- Fit the legs to the oven.
- Check that the available power and gas supply is correct to that shown on the rating plate located on the right -hand side panel.

### Location

- This oven must be installed in an area of adequate air supply. To ensure correct ventilation for the motor and controls the following minimum installation clearances are to be adhered to:

Rear	75mm / 3"
Left-hand side	75mm / 3"
Right-hand side*	75mm / 3"
Top	200mm / 8"
- \* Fixed installations require at least 500mm (20") clearance at the right hand side for service accessibility.
- This oven must be fitted on supplied legs in all installations.
- Position the oven in its working position.
- Use a spirit level to ensure oven is level from side to side and front to back. (If this is not carried out, uneven cooking could occur). The legs used with bench/floor mounting or provided with stands are adjustable and will require adjusting in levelling the unit.
- The unit should be positioned such that the operating panel and oven shelves are easily reachable for loading and unloading.
- Adequate ventilation is essential. DO NOT obstruct the air flow around the ventilation slots.

 **IMPORTANT: THE OVEN VENT LOCATED ON THE CABINET TOP MUST NEVER BE OBSTRUCTED.**

### Electrical Connection

This oven is fitted with an approved power supply cord via an electrical junction box at the right hand rear of the unit. Should

changing of the cord be necessary then follow the instructions given below:

- Remove right hand side panel to allow access to the terminal block and strain relief cable clamp.
- The cable can be fitted through the small grommet and held by the cable clamp.
- Connect cable to the terminals as marked, then refit the cover panel.

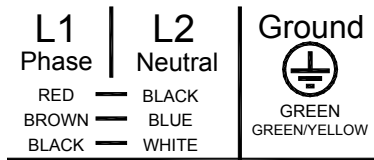

WARNING: THIS APPLIANCE MUST BE GROUNDED / EARTHED

Figure 2.1

### Gas Connection

- A 1/2" BSP female elbow (1/2" N.P.T female - USA / Canada only) is provided at the bottom rear of the oven.
- A restraint chain anchor has been provided above the gas connection point for fitment of a restraint chain when a flexible gas line is fitted.
- It is important that adequately sized piping run directly to the connection joint on the oven with as few tees and elbows as possible to give maximum supply volume.
- A suitable jointing compound which resists the break down action of LPG must be used on every gas connection.
- Check all connections for leakages.
- Check appliance name plate on oven right hand side for correct orifice size and operating pressure for the gas being installed, before operation.
- The appliance combination gas valve is fitted with an internal regulator for adjusting the operating pressure. To access, remove appropriately marked side service panel from bottom right side of oven. Unscrew and remove regulator cap from gas valve. Adjust the regulator to achieve stated pressure.

**NOTE:** Pressure test points are located behind this side service panel also at bottom right side of oven.

**!** **IMPORTANT:** ENSURE MANUAL ISOLATING VALVE LOCATED ON RIGHT HAND SIDE OF OVEN BEHIND GAS CONTROL SERVICE PANEL IS OPENED FOR OPERATION.

### Water Connection

- A cold water supply should be fitted to the water inlet (3/4" BSP hose connection) which is located on the rear of the right hand side of the unit.
- Alternately, a connection elbow and sealing washer is supplied with this unit for direct connection of a 1/2" ID hose, and is recommended for easy installation and service.
- Connect water supply - Max inlet pressure 80psi / 550kPa.
- Turn on water supply to check for leaks.

**!** **IMPORTANT:** MAXIMUM INLET WATER PRESSURE IS 550 kPa / 80 psi.

### Before Use

- Operate the oven for about 1 hour at 200°C (400°F) to remove any fumes or odours which may be present.

### Lighting Instructions

- Set the thermostat temperature.
- Automatic ignition will light the burner.
- If not, turn the thermostat off, and wait 5 minutes before relighting.
- The burner will cycle on/off to maintain the set temperature.
- Turn the thermostat off to shut-down the burner.

**NOTE:** If the burner is not cycling to maintain temperature the ignition system has locked out. To reset turn the thermostat to the 'off' position. Wait 5 minutes before relighting.

### 110 Volt Models (24 Volt ignition system)

If the flame is lost during operation the ignition system will try three times to re-establish the flame with a 30 second delay between each try, before going into lockout.

### 220-240 Volt Models

If the flame is lost during operation the ignition system will try once to re-establish the flame, and will go into lock-out condition if there is a re-ignition failure.

---

## RATING PLATE LOCATION

### Units manufactured from July 2002.

The rating plate for the G32M and G32MS convection ovens is located on the RH side front bottom corner.



Figure 2.2

### Units manufactured up to July 2002.

The rating plate for the G32M and G32MS convection ovens is located at the rear of the RH side panel.

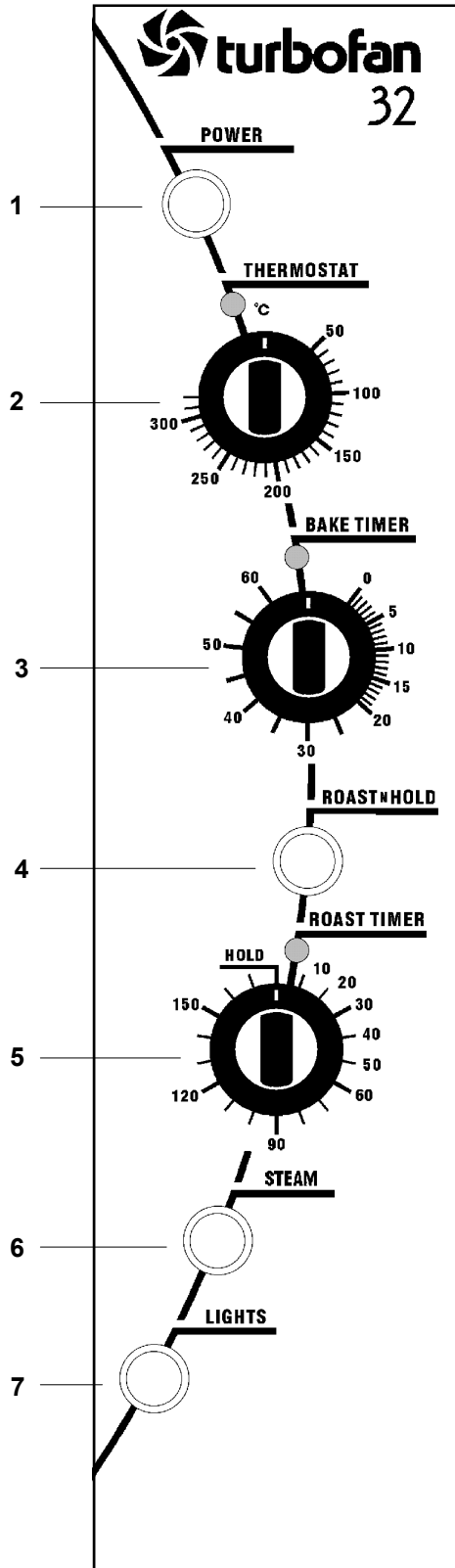

Figure 2.3

## 3. OPERATION

**NOTE:** A full user's operation manual is supplied with the product and can be used for further referencing of installation, operation and service.

### 3.1 DESCRIPTION OF CONTROLS



#### 1. Power

Depress to switch power on or off (switch illuminates when power is on).

#### 2. Thermostat

Temperature range 50 - 320°C (120 - 600°F). Indicator illuminates when the burner is cycling ON to maintain set temperature.

#### 3. Bake Timer

1 Hour bake timer. Indicator illuminates when "time up" (0) reached, and buzzer sounds.

#### 4. Roast 'n' Hold

Depress switch to activate 'Roast 'n' Hold' function. (Switch illuminates when ON).

#### 5. Roast Timer

3 Hour roast timer. Indicator illuminates when "time up" (0) reached. Product is held at 75°C (167°F).

#### 6. Steam Switch

Push switch to activate water injection. (Water injects into oven while the button is depressed).

#### 7. Light Switch

Push switch to activate lights. (Lights illuminate while button is latched in the down position).

---

## 3.2 EXPLANATION OF CONTROL SYSTEM

The G32M and G32MS Turbofan convection ovens feature multi-function operator controls for which a correct understanding of their operation is required before carrying out any service or fault repair work. The control device functions are explained as follows:

A power switch on the control panel isolates all to the controls of the oven. With the power switch Off all functions of the oven are inoperable.

With the power switch On (illuminated) power is directly supplied to the 60 minute bake timer, steam (water injection) switch, door microswitch, light switch, the temperature control circuit, and the fan motor. The oven circulation fan will continuously run whenever the oven is switched on. The control panel light switch will turn the oven lights on when the door is closed. The oven lights will come on automatically when the door is open, as this is controlled by the door microswitch.

The 60 minute timer is a mechanical timer and can therefore be operated with the oven's power switch On or Off. However, only with the oven's power switch On will the switch contacts of the 60 minute timer turn on the time-up buzzer and illuminate the time-up indicator on the control panel. The buzzer and time-up indicator provide indication that the time setting has run down to zero and at this point will remain On continuously until the 60 minute timer has been manually set back to the Off (vertical) position. The 60 minute timer does not control any other part of the oven's operating system as this timer is independent of the temperature control and heating system.

The steam (water injection) switch on the control panel can be operated whenever the power switch is On. The switch is momentary and when depressed will operate the electric solenoid valve at the rear of the oven and inject water across the oven fan from the flat spray (vertical) nozzle positioned at the rear of the oven. Releasing the steam button will close the solenoid valve. This feature is used to instantaneously add steam into the oven.

The temperature control of this oven is with a capillary type thermostat which can be set to a required cooking temperature.

The control panel indicator light above the thermostat knob cycles On and Off with the thermostat to indicate when the gas burners are on and the oven is heating.

The G32M and G32MS Turbofan ovens have an infrared surface combustion burner fitted in a burner box underside the oven. The burner box is directly ducted into the oven chamber through a flue duct connecting to an opening behind the oven circulation fan. The fan draws the burner box heated air and products of combustion directly into the oven chamber (directly fired system) to maximise performance. A flue exit in the top of the oven chamber provides final flueing of the combustion products out of the oven.

The burner being of an infrared type is provided with primary combustion air at the injector orifice intake at the front of the burner, and draws in the primary air through the venturi effect of the burner mixer tube elbow. Additional secondary air is provided in the burner box via an air intake on the underside of the burner box that is intake ducted to the air openings on the right hand side of the G32 base assembly. The addition of the secondary air allows for complete combustion of the gas due to the infrared burner being under the draft conditions of the oven fan extraction on the burner box. Accordingly, the infrared burner will display conventional surface combustion infrared combustion characteristics as well as having a flame plume drafted toward the right hand side of the oven (toward the burner box flue duct) when viewed from the front of the oven, after removal of the front service panel.

The burner is automatically controlled by the main oven thermostat or hold thermostat, via an automatic ignition and valve control device, which operates a gas solenoid valve to provide gas to the burner as required to maintain the set thermostat temperature.

**NOTE:** On 110 volt models the ignition control and gas control valve operate on 24 volts AC through a 110 volt - 24 volt transformer. For these models the thermostat powers the transformer, whereas on 220-240 volt models the thermostat powers the ignition control directly.

On the thermostat calling for heat, the thermostat will switch power to the ignition control. The ignition control will then power the gas control valve to open the solenoids

---

and provide gas to the burner. At the same time the ignition control will generate a high voltage ignition spark sequence conveyed to the ignition electrodes mounted at the front of the burner and oven through a high tension ignition cable. The spark and earth ignition electrodes will spark across the end gap between these two to ignite the burner.

On successful ignition of the burner the third electrode, being a flame rectification rod, will be in the burner flame. This provides the ignition control with confirmation that the burner is lit by establishing a micro-amp current from the electrode to earth through the flame due to combustion flames being ionised and therefore able to conduct minute electrical currents. The flame electrode is connected to the ignition control with an insulated wire conductor.

If this ignition sequence occurs correctly the spark sequence will be stopped and the burner will continue to operate until the thermostat switches off and shuts down the ignition control and consequently closes the gas solenoid valve.

Should the ignition control not sense the burner flame within a fixed ignition / spark sequence period, the ignition control will lock-out and turn off the gas solenoid valve on 220-240 volt models. Lock-out condition requires the oven thermostat to be switched off before operation can be restarted. On 110 volt models only, an unsuccessful ignition attempt will be followed by a 30 second purge with the gas control valve shut, then re-attempt ignition automatically. 2 re-ignition retries will be attempted. If unsuccessful the ignition control will then lock-out and shut the gas valve off.

If the ignition control loses the burner flame during an on period, a re-ignition attempt will be started automatically. If this is unsuccessful the ignition will go to lock-out mode.

**NOTE:** Different voltage and market models have different ignition sequence and re-ignition specifications. Refer to appendix A for specific model details.

The gas solenoid valve also includes the gas regulator and on installation is adjusted to achieve correct burner gas operating pressure.

The G32M and G32MS Turbofan convection ovens feature a Roast-and-Hold system which

can be used to automatically set the oven to a fixed holding temperature at the end of a timed cooking period. When the Roast-and-Hold switch is turned On the switch will illuminate and switch on a relay found inside the control panel, at the base of the control housing next to the door microswitch. When the relay is switched ON a normally closed switch pole on the relay is opened and the normal power supply to the oven thermostat is isolated. A second normally open switch pole is closed and this provides power to the 3 hour roast timer.

If the roast timer is in the Hold (vertical) position the timer switch contacts will be in their normally closed position and supply power directly to the Hold thermostat located behind the control panel. The Hold thermostat is factory set to 75°C (167°F) and will supply power to the ignition and gas burner as required to maintain its preset temperature.

The thermostat heating light will also cycle On/Off as the Hold thermostat maintains temperature.

In the Roast-and Hold mode the 3 hour timer can be set to a selected roasting time. During this time period the normally open switch contacts of the timer are closed. The timer has two change over switches and in this position one is used to supply power to its timing motor and the other is used to switch power directly to the main oven thermostat. During the 3 hour timer run-down period the oven temperature will be controlled by the main oven thermostat to the set temperature and operate as previously described.

When the 3 hour timer has run down and reached the Hold position the two switch contacts change over to their normally closed position which isolates power from the timer motor and the oven thermostat. It also switches power back to the oven hold thermostat. At this point the temperature control is now maintained by the hold thermostat as previously described. To cancel the hold circuit the Roast-and-Hold switch is turned Off. This turns off the relay which removes power from the 3 hour timer and closes the pole on the relay that feeds the main oven thermostat. The Hold indicator light above the 3 Hour timer will illuminate whenever the oven is operating in hold mode (Roast 'n Hold selected, and 3 Hour timer at zero position).

---

The factory preset hold thermostat can be adjusted as required to change the holding temperature if necessary. Refer Service section for this procedure.

The Troubleshooting Guide (Section 5) should be used to identify any incorrect oven operation. On correct identification of the operating fault the Troubleshooting Guide will make reference to the corrective action required, or refer to the Fault Diagnosis section and/or Service section to assist in correction of the fault.

## 4. MAINTENANCE

 **WARNING:** ALL INSTALLATION AND SERVICE REPAIR WORK MUST BE CARRIED OUT BY QUALIFIED PERSONS ONLY.

### 4.1 CLEANING

 **WARNING:** ALWAYS TURN THE POWER SUPPLY OFF BEFORE CLEANING.

 **IMPORTANT:** THIS UNIT IS NOT WATER PROOF. DO NOT USE A WATER JET SPRAY TO CLEAN INTERIOR OR EXTERIOR OF THIS UNIT.

#### EXTERIOR

Clean with a good quality stainless steel cleaning compound. Harsh abrasive cleaners may damage the surface.

Do not use oven cleaners or caustic solutions to clean the control panel as these cleaners will damage plastic components.

#### INTERIOR

Ensure that the oven chamber is cool. Do not use wire brushes, steel wool or other abrasive materials. Clean the oven regularly with a good quality oven cleaner. Take care not to damage the fan or the tube at the right side of the oven which controls the thermostat.

#### OVEN RACKS

To remove, slide out to the stop position, raise the front edge up, and lift out.

#### SIDE RACKS

To remove, lift front top to disengage and slide rack forward. To replace, slide top rear slot in rack onto rear stud, then engage front keyhole on front stud.

#### OVEN BASE TRAY

Remove when cleaning oven, and to allow easier cleaning of enamelled base tray. Ensure tray is refitted before use.

#### LAMP GLASS

To remove glasses, unscrew anti-clockwise. To replace, screw in clockwise.

 **IMPORTANT:** DO NOT OVER TIGHTEN LAMP GLASS. NEVER OPERATE OVEN WITH LAMP GLASSES REMOVED

#### OVEN SEALS

To remove, hold at their centre point and pull forward until they unclip. Remove side seals first, then top and bottom. The seals may be washed in the sink, but take care not to cut or damage them. To replace, ensure that the lip is facing the oven opening. Fit the top and bottom seals first, then the side seals.

#### OVEN DOOR GLASS

Clean with conventional glass cleaners.

---

## 4.2 ROUTINE PROCEDURES

	<b>PROCEDURE</b>	<b>INTERVAL</b>
DOOR SEALS	Check for deterioration.	12 months
DOOR PIVOT BUSHES	Check for wear.	12 months
DOOR CATCH	Ensure that catch is adjusted such that the door closes properly.	12 months
WATER NOZZLE	Check for liming in water nozzle.	12 months
HT LEAD / ELECTRODE	Check for deterioration.	12 months
BURNER PRESSURE	Check that the unit is operating at the correct operating pressure.	12 months

## 5. TROUBLE SHOOTING

**⚠ WARNING: ALL INSTALLATION AND SERVICE REPAIR WORK MUST BE CARRIED OUT BY QUALIFIED PERSONS ONLY.**

FAULT	POSSIBLE CAUSE	REMEDY
THE OVEN DOES NOT OPERATE / START	<p>The mains isolating switch on the wall, circuit breaker or fuses are "off" at the power board.</p> <p>The power switch on the oven is off.</p> <p>Incorrect electrical supply. <b>(Refer fault diagnosis 6.1.1)</b></p> <p>Overtemp tripped (UK only). <b>(Refer fault diagnosis 6.1.1)</b></p> <p>Power switch on unit faulty. <b>(Refer fault diagnosis 6.1.1)</b></p>	<p>Turn on.</p> <p>Depress switch. Switch will illuminate.</p> <p>Ensure electrical supply correct.</p> <p>Reset / replace overtemp. <b>(Refer service section 6.3.16)</b></p> <p>Replace. <b>(Refer service section 6.3.4)</b></p>
NO HEAT / BURNER NOT WORKING	<p>Gas supply not turned on.</p> <p>Manual isolating valve on unit closed.</p> <p>Incorrect gas pressure setting for burner</p> <p>Blocked injector.</p> <p>Burner ignition spark faulty. <b>(Refer fault diagnosis 6.1.2)</b></p> <p>Burner flame not being sensed. <b>(Refer fault diagnosis 6.1.2)</b></p> <p>Ignition transformer faulty - 110V models only <b>(Refer fault diagnosis 6.1.2)</b></p> <p>Ignition / burner control box faulty. <b>(Refer fault diagnosis 6.1.2)</b></p> <p>Gas valve faulty. <b>(Refer fault diagnosis 6.1.2)</b></p> <p>No power to thermostat. <b>(Refer fault diagnosis 6.1.2)</b></p> <p>Thermostat faulty. <b>(Refer fault diagnosis 6.1.2)</b></p>	<p>Turn on gas supply</p> <p>Remove r/h service panel and turn on/open isolating valve.</p> <p>Set correct regulator pressure. <b>(Refer section 2: Installation for correct setting procedure)</b></p> <p>Clean / replace. <b>(Refer service section 6.3.21)</b></p> <p><b>(Refer fault diagnosis 6.1.2)</b></p> <p><b>(Refer fault diagnosis 6.1.2)</b></p> <p>Replace. <b>(Refer service section 6.3.17)</b></p> <p>Replace. <b>(Refer service section 6.3.18)</b></p> <p>Replace. <b>(Refer service section 6.3.20)</b></p> <p>Identify fault and correct.</p> <p>Replace. <b>(Refer service section 6.3.9)</b></p>

FAULT	POSSIBLE CAUSE	REMEDY
<p>BURNER INCORRECT COLOUR (Refer installation section—<b>Gas Connection and Adjustment for correct colour</b>)</p>	<p>Incorrect gas type.</p> <p>Incorrect burner orifice size fitted.</p> <p>Incorrect burner pressure setting.</p> <p>Obstructed burner injector.</p> <p>Burner obstructed.</p> <p>Oven flue obstructed.</p> <p>Oven fan obstructed.</p> <p>Injector out of alignment.</p>	<p>Check appliance gas type. <b>(Refer installation section)</b></p> <p>Ensure orifice is correct. <b>(Refer specification section)</b></p> <p>Check gas pressure. <b>(Refer installation section— Gas Connection and Adjustment)</b></p> <p>Check injector. <b>(Refer service section 6.3.21)</b></p> <p>Remove burner and inspect for obstructions. <b>(Refer service section 6.3.22)</b></p> <p>Check for obstructions.</p> <p>Check for obstructions.</p> <p>Check injector alignment. <b>(Refer service section 6.4.9)</b></p>
<p>BURNER NOISY (BURNER BLOWBACK / BURNER BACKFIRE)</p>	<p>Oven not installed with correct legs / feet fitted. (Not applicable to units on stands)</p> <p>Installation clearances not correct.</p> <p>Gas leak.</p> <p>Flue obstruction.</p> <p>Oven fan not operating. <b>(Refer Fault: Fan doesn't operate)</b></p> <p>Burner obstruction.</p> <p>Burner faulty. <b>(Refer fault diagnosis 6.1.3)</b></p>	<p>Fit correct legs/feet <b>(Refer installation section)</b></p> <p>Ensure correct installation clearances. <b>(Refer installation section)</b></p> <p>Leak test and repair.</p> <p>Ensure oven flue/vent on top of oven is not obstructed.</p> <p>Ensure oven flue/vent not blocked on inside of oven.</p> <p>Remove burner and inspect for obstruction. <b>(Refer service section 6.3.22)</b></p> <p>Replace. <b>(Refer service section 6.3.22)</b></p>

FAULT	POSSIBLE CAUSE	REMEDY
FAN DOESN'T OPERATE	Fan motor faulty. <b>(Refer fault diagnosis 6.1.4)</b>  Wiring.	Replace. <b>(Refer service section 6.3.15)</b>  Check and tighten any loose wiring.
OVEN LIGHT NOT ILLUMINATING - DOOR OPEN (AUTOMATICALLY ON)  OVEN LIGHT NOT ILLUMINATING - DOOR CLOSED (MANUALLY SWITCHED ON)	Blown bulb.  No power to light. <b>(Refer fault diagnosis 6.1.5)</b>  Blown bulb.  Light switch faulty. <b>(Refer fault diagnosis 6.1.6)</b>	Replace. <b>(Refer service section 6.3.1)</b>  Correct fault.  Replace. <b>(Refer service section 6.3.1)</b>  Replace. <b>(Refer service section 6.3.4)</b>
NO WATER INJECTION / STEAM	Water not turned on.  Oven water nozzle blocked.  Fault with water valve. <b>(Refer fault diagnosis 6.1.7)</b>  Steam switch faulty. <b>(Refer fault diagnosis 6.1.7)</b>	Turn water on at water supply.  Remove, clean or replace. <b>(Refer service section 6.3.13)</b>  Service or replace as required. <b>(Refer service section 6.3.11, 6.3.12)</b>  Replace. <b>(Refer service section 6.3.4)</b>
CONTINUOUS WATER OUT OF OVEN WATER NOZZLE	With oven on only—Electrical fault. <b>(Refer fault diagnosis 6.1.8)</b>  With oven on or off - water valve faulty or requires cleaning.	Correct electrical fault.  Service or replace as required. <b>(Refer service section 6.3.11, 6.3.12)</b>
60 MINUTE TIMER WILL NOT TIME DOWN  60 MINUTE TIMER INACCURATE BELOW 20 MINUTES  60 MINUTE TIMER NO TIME UP BUZZER  60 MINUTE TIMER NO TIME UP INDICATOR	Timer faulty.  Timer not set correctly.  Zero (time up) position not set correctly.  Buzzer faulty. <b>(Refer fault diagnosis 6.1.9)</b>  Timer not switching on buzzer. <b>(Refer fault diagnosis 6.1.9)</b>  Indicator faulty. <b>(Refer fault diagnosis 6.1.10)</b>	Replace. <b>(Refer service section 6.3.7)</b>  For timer settings below 20 minutes, always rotate past 20 minutes, then back to desired time.  <b>(Refer service section 6.4.8)</b>  Replace. <b>(Refer service section 6.3.5)</b>  Replace. <b>(Refer service section 6.3.7)</b>  Replace. <b>(Refer service section 6.3.3)</b>

FAULT	POSSIBLE CAUSE	REMEDY
NO TEMPERATURE CONTROL (TEMPERATURE OVERRUN)	Thermostat faulty. <b>(Refer fault diagnosis 6.1.11)</b>	Replace. <b>(Refer service section 6.3.9)</b>
SLOW RECOVERY	Oven in 'Roast 'n Hold' mode. Overloading of oven. Fan not working. Thermostat out of calibration. <b>(Refer fault diagnosis 6.1.12)</b> Low gas pressure. Blocked burner orifice. Incorrect gas type.	Switch off 'Roast 'n Hold'. Reduce oven loading. Check fan operation. Correct calibration. <b>(Refer service section 6.4.2)</b> Check and adjust. <b>(Refer section 2: Installation for correct setting procedure)</b> Clean. <b>(Refer service section 6.3.21)</b> Check appliance gas type.
NO THERMOSTAT HEATING INDICATOR	Indicator faulty. <b>(Refer fault diagnosis 6.1.13)</b>	Replace. <b>(Refer service section 6.3.3)</b>
ROAST TIMER (180 MINUTE) WILL NOT TIME DOWN	Roast 'n' Hold switch not depressed. No power to timer / timer faulty. <b>(Refer fault diagnosis 6.1.14)</b>	Depress switch. Switch will illuminate. Correct electrical fault / replace timer. <b>(Refer service section 6.3.8)</b>
NO HOLD INDICATOR	'Roast 'n Hold' switch faulty. <b>(Refer fault diagnosis 6.1.14)</b> Faulty indicator. <b>(Refer fault diagnosis 6.1.15)</b> Faulty timer. <b>(Refer fault diagnosis 6.1.15)</b>	Replace. <b>(Refer service section 6.3.4)</b> Replace. <b>(Refer service section 6.3.3)</b> Replace. <b>(Refer service section 6.3.8)</b>
HOLDING TEMPERATURE INCORRECT	Hold thermostat set temperature incorrect. Hold thermostat faulty. <b>(Refer fault diagnosis 6.1.16)</b>	Adjust to correct temperature. <b>(Refer service section 6.4.7)</b> Replace. <b>(Refer service section 6.3.10)</b>

FAULT	POSSIBLE CAUSE	REMEDY
DOOR DOES NOT CLOSE	<p>Tray in way of door.</p> <p>Door seal obstruction.</p> <p>Door handle installed incorrectly.</p> <p>Door catch setting incorrect.</p> <p>Door pivot bushes / pins worn.</p>	<p>Correctly position tray in rack.</p> <p>Correctly install door seal. <b>(Refer service section 6.3.25)</b></p> <p>Fit correctly. <b>(Refer installation section)</b></p> <p>Adjust. <b>(Refer service section 6.4.5)</b></p> <p>Replace. <b>(Refer service section 6.3.26)</b></p>
DOOR SEAL LEAKS	<p>Door seal damaged.</p> <p>Door seal incorrectly fitted.</p> <p>Door catch setting incorrect.</p> <p>Door pivot bushes / pins worn.</p> <p>Door ctch striker plate worn.</p>	<p>Replace. <b>(Refer service section 6.3.25)</b></p> <p>Correctly install door seal. <b>(Refer service section 6.3.25)</b></p> <p>Adjust. <b>(Refer service section 6.4.5)</b></p> <p>Replace. <b>(Refer service section 6.3.26)</b></p> <p>Replace. <b>(Refer installation instructions—Door handle installation)</b></p>
Burner Ignites then goes out every time.	Check Phase and Neutral at supply for correct polarisation.	<b>(Refer service section 6.1.1)</b>

## 6. SERVICE PROCEDURES

 **WARNING:** ENSURE POWER SUPPLY IS SWITCHED OFF BEFORE SERVICING.

 **WARNING:** ALL INSTALLATION AND SERVICE REPAIR WORK MUST BE CARRIED OUT BY QUALIFIED PERSONS ONLY.

SECTION	PAGE NO.
<b>6.1 FAULT DIAGNOSIS</b> .....	<b>24</b>
6.1.1 Oven Does Not Operate / Start.....	24
6.1.2 No Heat / Burner Not Working .....	24
6.1.3 Burner Noisy (Burner Blowback / Backfire) .....	27
6.1.4 Fan Does Not Operate.....	27
6.1.5 Oven Light Not Illuminating—Door Open .....	27
6.1.6 Oven Light Not Illuminating—Door Closed .....	28
6.1.7 No Water Injection / Steam .....	28
6.1.8 Continuous Water Out Of Oven Water Nozzle .....	28
6.1.9 60 Minute Timer No Time Up Buzzer .....	28
6.1.10 60 Minute Timer No Time Up Indicator.....	29
6.1.11 No Temperature Control (Temperature Overrun).....	29
6.1.12 Slow Recovery .....	29
6.1.13 No Thermostat Heating Indicator .....	29
6.1.14 Roast Timer (180 Minute) Will Not Time Down .....	29
6.1.15 No Hold Indicator .....	30
6.1.16 Holding Temperature Incorrect.....	30
<b>6.2 ACCESS</b> .....	<b>30</b>
6.2.1 Control Panel .....	30
6.2.2 Service Panel (Side Panel) .....	30
6.2.3 Burner Access Panel .....	31
6.2.4 Manual Isolating Valve / Gas Control Valve Access Panel .....	31
6.2.5 Control Panel (Rear).....	31
<b>6.3 REPLACEMENT</b> .....	<b>32</b>
6.3.1 Lamp Bulb / Glass.....	32
6.3.2 Door Microswitch .....	32
6.3.3 Indicator Neon Light.....	32
6.3.4 Power / Roast / Lights / Water Switches.....	32
6.3.5 Buzzer .....	32
6.3.6 Hold Relay.....	33
6.3.7 Bake Timer.....	33
6.3.8 Roast Timer.....	33
6.3.9 Thermostat.....	33
6.3.10 Hold Thermostat .....	34
6.3.11 Water Solenoid .....	34
6.3.12 Water Solenoid Cleaning .....	34
6.3.13 Spray Nozzle.....	35
6.3.14 Fan .....	35
6.3.15 Motor .....	35
6.3.16 Overtemp (UK Units Only) .....	35
6.3.17 24 Volt Transformer (USA/Canada Units Only).....	36

---

6.3.18	Ignition Box .....	36
6.3.19	Ignition Electrodes .....	36
6.3.20	Gas Control Valve .....	37
6.3.21	Burner Injector .....	37
6.3.22	Burner .....	37
6.3.23	Outer Glass .....	37
6.3.24	Inner Glass .....	38
6.3.25	Door Seals .....	38
6.3.26	Door Pivot Bushes .....	38
6.3.27	Stainless Steel Door Outer Glass .....	38
6.3.28	Stainless Steel Door Inner Glass .....	39
<b>6.4</b>	<b>ADJUSTMENT / CALIBRATION .....</b>	<b>39</b>
6.4.1	Regulator Adjustment .....	39
6.4.2	Thermostat Calibration .....	39
6.4.3	Confirming Overtemp Thermostat Calibration (UK Units Only) .....	40
6.4.4	Door Microswitch Adjustment .....	40
6.4.5	Reversing the Door .....	40
6.4.6	Door Roller Catch Adjustment .....	41
6.4.7	Door Alignment .....	41
6.4.8	Hold Temperature Adjustment .....	41
6.4.9	60 Minute Timer Zero Position Adjustment .....	41
6.4.10	Burner Injector Alignment .....	42
6.4.11	Ignition Electrode Adjustment .....	42
6.4.12	Gas Type Conversion .....	42

---

## 6.1 FAULT DIAGNOSIS

---

### 6.1.1 OVEN DOES NOT OPERATE / START

---

#### Incorrect electrical supply

Check that the voltage across phase and neutral (L1 and L2) terminals of terminal block is the voltage as stated on the unit's electrical rating plate.

If incorrect, check electrical connection of supply wiring and / or check electrical supply.

#### Overtemp tripped (UK units only)

Open the control panel. Check for power at terminal 1 of power switch. If power at terminal 1 then overtemp is ok, refer "power switch faulty" (below).

 **WARNING: OVERTEMP BUTTON IS LIVE. ISOLATE UNIT FROM POWER SUPPLY BEFORE RESETTING.**

If no power to terminal 1, inspect overtemp reset button (at rear of control cavity). If the overtemp has tripped then the reset button will have popped out, and will click when depressed. If the overtemp resets then a fault exists with the temperature control of the oven (check calibration, refer 6.4.2, or overtemp calibration is faulty, refer 6.4.3).

If the overtemp button cannot be reset, and the oven temperature is below 300°C (- overtemp will not reset above 300°C), then the overtemp is faulty - replace.

#### Power switch faulty

Check if power switch latches. If the switch does not latch, then switch is faulty—replace.

With switch latched, check voltage across terminal one to terminal three or four. If there is no voltage, check for fault in wiring.

Check voltage across terminal two to terminal three or four. If there is no voltage, then switch is faulty—replace.

**NOTE:** When power switch is latched, it should illuminate if it is operating correctly.

---

### 6.1.2 NO HEAT/BURNER NOT WORKING

---

#### Burner ignition spark not working

A faulty spark system is one that does not light the burner at all. If the burner is being lit

temporarily, but fails to stay alight, then the problem is in the flame sensing, not spark ignition. Refer "Burner flame not being sensed" (following).

Firstly determine if spark is being generated. Remove the front service panel and turn the thermostat on to initiate a heating cycle. Look through the round viewing holes next to the electrode assembly, and look for spark generation at the end of the electrodes. If spark is heard but not visible, **turn off/isolate gas supply**, and remove electrode assembly.

With gas supply off, turn thermostat back on again with electrode assembly suspended in air. A correctly functioning ignition system should show sparking visible across spark and earth rod ends. If spark is not seen at electrode ends, or sparking is erratic, this indicates that there is a high voltage short/breakdown between the ignition box and the electrode ends.

Possible causes to investigate are as follows, inspect and correct as necessary:

- Spark gap too large (see the following section).
- Cracked spark rod ceramic, or carbon build-up.
- HT leads to spark electrode and earth broken/deteriorated.
- HT leads between ignition electrodes and ignition control box broken/deteriorated.
- No spark from ignition box, refer ignition box faulty.

#### Spark gap setting

With spark electrode assembly removed, inspect spark rod and earth electrode settings, and spark gap settings - refer section 6.4.11.

**NOTE:** Use drill bits to gauge spark gap settings

With spark system correctly checked, re-install into burner box and re-check operation.

If fault persists it is possible that the electrodes are out of position in relation to the burner flame. Adjustment may be necessary to set the electrode gap to the correct position (refer to following diagram).

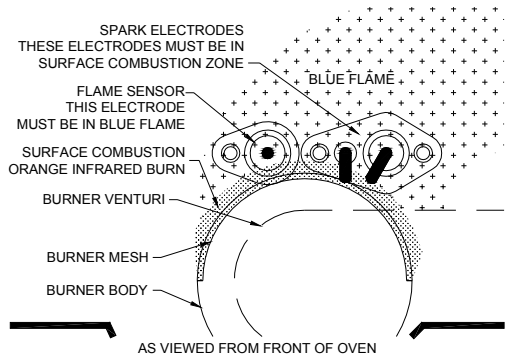

Figure 6.1.1

### Burner flame not being sensed

Firstly check phase and neutral at supply for correct polarisation, as shown on terminal block label. If incorrect burner will light but flame sensor will not sense the flame.

The flame sensing electrode requires correct positioning in the burner flame. Incorrect gas pressures, types, injector sizes, etc will affect correct operation of flame sensing system. Ensure that these are checked and correct before carrying out further investigation. Also, an incorrectly earthed/grounded appliance will cause faults with the flame sensing system. Always ensure a correct earth/ground connection on the appliance connection and supply.

If the flame rod is touching the burner mesh then there is a short circuit to earth, and this will cause the ignition control to not sense the flame correctly. As the relationship of the flame rod to the burner mesh cannot normally be seen, this fault would normally be indicated by a burner that fails to stay alight during operation, or during an ignition attempt the sparking continues after the burner is lit. The flame rod can be adjusted to be clear of the burner, as per the previous diagram (figure 6.1.1) and section 6.4.11.

Always inspect the connection lead from the flame rod to the ignition box for deterioration, bad connections, or insulation breakdown.

### Ignition transformer faulty - 110V models only

It is important to verify correct 110Vac - 24Vac transformer operation before checking these 24Vac Ignition Control Boxes.

With control panel open check transformer primary and secondary voltages are correct.

Transformer Primary Winding - 110-120Vac

Lead colours      White - L1 (Phase)  
                           Black - L2 (Neutral)

Check voltage at the black and white lead connections on control panel. Voltage should

be 110-120Vac. If not, check for wiring or power supply fault.

Transformer Secondary Winding - 24Vac

Lead colours - yellow and blue

Check voltage at yellow and blue lead connections on ignition control box. With thermostat on (calling for heat) voltage should be 24Vac  $\pm$  4Vac across yellow and blue leads. If not, check transformer thermal breaker on rear of transformer for trip. If tripped, reset and recheck operation.

If the transformer cannot be reset, or if transformer has not tripped out, but secondary output voltage is incorrect, then transformer is faulty - replace.

### Ignition box faulty - 110V models only

The direct spark ignition control boxes used on 110V model G32M and G32MS's are 24Vac type.

To check correct operation open control panel. With power on, turn thermostat on so heating indicator on control panel illuminates (calling for heat).

Correct ignition box operation should result in ignition box commencing spark at ignition electrodes and opening gas valve to ignite burner, then maintain burner ON after successful ignition.

If no spark is generated or heard, check that ignition box has correct supply voltage. (Check voltage across terminal 'GND' (black/green wire) and 'TH' (blue wire)). 24Vac  $\pm$  4Vac should be measured across these terminals with thermostat on and calling for heat. If not, check transformer (refer previous).

If voltage correct, but no spark generated, check ignition box Fault Diagnostic LED indicator status. The Diagnostic LED is at the top of the ignition box.

Inspect for Diagnostic Indicator as follows:

- 2 Flashes      Indicates that there was a flame already present when ignition attempted.

Possible gas valve fault (burner staying on). Refer to fault diagnosis - Gas Valve Faulty.

- 3 Flashes      Indicates LOCK-OUT condition.

Possible flame rectification rod short to earth. Refer to fault diagnosis 6.1.2 - Burner Flame Not Being Sensed.

If ignition box fault indicator LED does not identify fault, and voltage correct but no spark generated, ignition box is faulty - replace.

---

**NOTE:** Ensure all wiring and connections to ignition box are correct before replacing.

**Ensure unit has Earth/Ground connection on unit and at supply.**

If ignition box generates a spark, but burner doesn't ignite, or if burner ignites but doesn't stay alight, firstly check correct electrode assembly operation. Refer fault diagnosis 6.1.2 - Burner Ignition Spark Not Working.

If all checks are correct, but burner fails to stay alight then burner box is faulty - replace.

**NOTE:** Correct flame sensing current can be checked by inserting a multi-meter capable of measuring micro-amps in series with flame rectification rod connection to ignition box. With power off, disconnect flame rectification rod connection to ignition box (terminal 'S1' on Fenwal models), and connect multimeter between flame rectification rod lead and ignition box terminal. Turn on power and thermostat. With burner running a current of no less than that specified below should be read.

Fenwal Models                      0.7 micro Amps

If no current reading, or less than specified, re-check electrode settings, gas pressure, gas type etc, and if still not correct, ignition box requires replacement.

**Ignition box faulty - 220-240 Volt models only**

The direct spark ignition control boxes used on 220-240 volt model G32's are operated from direct voltage supply from the thermostat / hold thermostat circuit.

Correct ignition box operation should result in ignition box commencing spark at ignition electrodes and opening gas valve to ignite burner, then maintain burner on after successful ignition.

**IMPORTANT:** These models have a pre-purge period of 5 seconds before the spark and gas valve opening commences.

For all 220-240 volt models after using SIT ignition boxes, check correct supply voltage across terminal T10 (red phase wire), and terminal T12 (black neutral wire) on ignition box.

The measured voltage should equal the supply voltage, ie 220-240 volts. If not check wiring.

If voltage is ok, but no spark is generated,

check that all wiring at ignition box has good connections.

Ensure that the ignition box has earth/ground connection, and that appliance has earth/ground at supply, and supply is earthed.

If all connections are ok, and no ignition sequence operating, then ignition box is faulty - replace.

If ignition box generates spark, but burner doesn't ignite, or if burner ignites but doesn't stay alight, firstly check correct electrode assembly operation. Refer fault diagnosis 6.1.2 - Burner Ignition Spark Not Working.

If all checks are correct, but burner fails to stay alight then ignition box is faulty - replace.

**NOTE:** Correct flame sensing current can be checked by inserting a multi-meter capable of measuring micro-amps in series with flame rectification rod connection to ignition box. With power off, disconnect flame rectification rod connection to ignition box and connect multimeter between flame rectification rod lead and ignition box terminal. Turn on power and thermostat. With burner running a current of no less than that specified below should be read.

All Models                      1.0 micro Amps

If no current reading, or less than specified, re-check electrode settings, gas pressure, gas type etc, and if still not correct, ignition box requires replacement.

**Gas valve faulty**

The gas valve performs two functions:

- Providing regulation of gas pressure for the burner,
- Opening and closing gas supply to the main burner.

In all cases it must first be established that the gas supply is on, that the manual isolating valve in line with the gas valve on the appliance is open, and that the supply pressure is equal to or greater than the required burner operating pressure (refer specification section).

To determine if valve solenoids are operating correctly, attach a pressure gauge to the burner pressure test point after the gas valve, and turn thermostat on. Check gas pressure. If pressure is not correct for the appliance specifications, remove the regulator cap on the gas valve, and adjust the regulator spring to increase or decrease the pressure. If the

pressure is unable to be adjusted, remove regulator spring and check for correct type:

LPG/Propane	Blue spring
Natural Gas	Green spring

If the regulator spring and supply pressure are correct, but the burner pressure is still incorrect, check the gas valve solenoid operation. With thermostat turned on check voltage at connections to the gas valve.

110 volt models should have 24 volt ac supply on both coils.

220-240 volt models should have 220-240 volts.

If voltage is correct when thermostat is on, and gas valve is not opening then the valve is faulty - replace. If voltage is incorrect, check wiring and connections to ignition box and refer to ignition box fault diagnosis.

#### No power to thermostat

Check voltage to terminal 2 on oven thermostat. If there is no voltage then check voltage through terminal 5 and one on hold relay (behind control panel). If there is no voltage to terminal 5 then check wiring. If there is no voltage to terminal 1 then check that the hold relay (fig 6.1.2) has no power at relay coil terminal 7. If relay coil is not energised (ie no power at 7) and no power out of terminal 1, then the relay is faulty—replace.

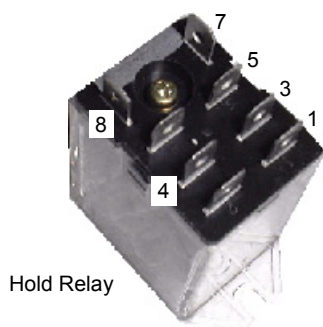

Figure 6.1.2

If relay is energised (ie power at 7) then 'Roast n Hold' switch is on and unit is in hold mode. Turn off 'Roast n Hold' and recheck operation.

**NOTE:** There should be no voltage across these terminals when 'Roast 'n Hold' is not selected.

#### Thermostat faulty

Set thermostat to 200°C or 400°F. Check the voltage out of terminal 1 on the thermostat. If there is no voltage then the thermostat is faulty—replace.

If the voltage is correct and the heating light is on then check all wiring to heating contactor.

### 6.1.3 BURNER NOISY

#### Burner faulty

With burner removed (refer 6.3.22), inspect burner for leak holes in construction and deterioration in mesh surfaces. Tears or corrosion holes in mesh will be evidence of faulty burner condition. Replace burner if faulty.

**NOTE:** Minor mesh surface buckling is normal, and will not necessitate burner replacement.

### 6.1.4 FAN DOESN'T OPERATE

#### Fan motor faulty

Check the supply voltage across motor terminals. If there is no voltage then check the electrical connections of wiring.

If voltage is correct then check the oven fan for free rotation. Remove any obstruction.

If fan is free to spin and the voltage at motor terminals is correct, then the motor is faulty—replace.

### 6.1.5 OVEN LIGHTS NOT ILLUMINATING—DOOR OPEN (AUTOMATICALLY ON)

#### No power to lights

Check the supply voltage across lamp housing terminals at RH side rear of oven. If the voltage is correct, replace the bulb (if faulty). If the bulb is OK, check lamp housing. Replace if faulty.

If there is no voltage, open oven door and manually depress door microswitch actuator at bottom right of oven. If this activates the lights, then the microswitch actuator arm behind the control panel requires adjustment.

Check voltage across micro-switch terminals to neutral.

With the door open there should be power to the com terminal and the n.c. terminal.

If not, microswitch is faulty—replace.

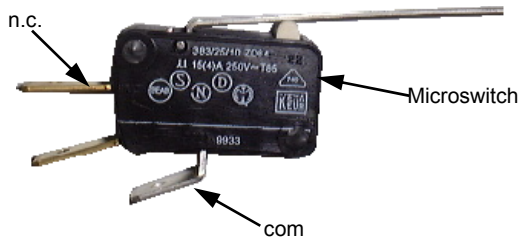

Figure 6.1.3

### 6.1.6 OVEN LIGHTS NOT ILLUMINATING— DOOR CLOSED (MANUALLY SWITCHED ON)

#### Light switch faulty

Check voltage to the bottom terminal of the switch. If there is no voltage, then check wiring.

With switch depressed, check voltage at top terminal. If there is no voltage, then replace the switch.

If voltage is correct, then check wiring to light.

**NOTE:** Alternately, perform a continuity test across the terminals with the light switch depressed.

### 6.1.7 NO WATER INJECTION / STEAM

#### Steam switch faulty

Check voltage to the bottom terminal of the switch. If there is no voltage, then check wiring.

With switch depressed, check voltage at top terminal. If there is no voltage, then replace the switch.

If voltage is correct, then check wiring to the solenoid.

**NOTE:** Alternately, perform a continuity test across the terminals with the steam switch depressed.

#### Fault with water valve

Check voltage supply across the water valve solenoid coil with the steam switch depressed. If there is no power supply then check the control panel steam switch.

Check voltage to the bottom terminal of the switch. If there is no voltage, then check wiring.

With switch depressed, check for voltage at top terminal. If there is no voltage then replace switch. If voltage correct, check wiring to solenoid coil.

If power supply to the coil is correct, disconnect wiring to coil and check the resistance of the coil windings.

Correct coil resistance:

208 - 240V	3650 ohms
110V	1085 ohms

**NOTE:** If open circuit / high resistance, then the coil is faulty—replace.

If coil resistance is correct, rewire and listen for an audible solenoid click when the steam switch is depressed.

If solenoid can be heard functioning, and oven water nozzle is not blocked, then remove water solenoid and fittings and check for blockages.

### 6.1.8 CONTINUOUS WATER OUT OF OVEN WATER NOZZLE

#### Water solenoid electrical fault

With control panel steam switch not depressed, check for power supply across solenoid coil. If there is power to the coil, then check wiring and steam switch (refer 6.1.7).

### 6.1.9 60 MINUTE TIMER NO TIME UP BUZZER

#### Buzzer faulty

With timer in 'zero' position, check the buzzer at side of control panel (inside) for voltage across terminals. If voltage is correct then buzzer is faulty—replace.

If there is no voltage, then check wiring.

#### Timer not switching on buzzer

With timer in zero position, check voltage to top connection (terminal one) and bottom connection (terminal two) of timer. If there is no voltage at terminal one then check wiring.

If no voltage at terminal two then timer is faulty—replace.

**NOTE:** Timer will continue to run approximately three minutes below zero. Buzzer and time up indicator will continue until the timer is manually switched off (to vertical position).

---

### 6.1.10 60 MINUTE TIMER NO TIME UP INDICATOR

---

#### Indicator faulty

With the timer in the zero position, check for voltage across the indicator light. If correct, then the indicator light is faulty—replace.

If there is no voltage then check wiring.

---

### 6.1.11 NO TEMPERATURE CONTROL (TEMPERATURE OVERRUN)

---

#### Thermostat faulty

With thermostat in off (vertical) position, the heating indicator should be off. If not then the thermostat is faulty—replace.

---

### 6.1.12 SLOW RECOVERY

---

#### Thermostat out of calibration

Place an accurate digital thermometer probe in centre of oven. Set thermostat to 180°C or 355°F. Close the oven door and allow oven thermostat to cycle on and off twice. Record oven centre temperature for the next thermostat on and off cycle. The thermostat should cycle on and off between 165°C and 195°C or 330°F and 385°F when set to the above temperature. If oven temperature is outside these ranges, then the thermostat requires recalibration.

**NOTE:** Thermostat cycling span should be  $\pm 15^{\circ}\text{C}$  or  $27^{\circ}\text{F}$

---

### 6.1.13 NO THERMOSTAT HEATING INDICATOR

---

#### Indicator faulty

Check the voltage across the indicator terminals. If the voltage is correct then the indicator is faulty—replace.

If there is no voltage then check wiring.

---

### 6.1.14 ROAST TIMER (180 MINUTE) WILL NOT TIME DOWN

---

#### No power to timer

Check the voltage at terminal 5 on underside of the 180 minute timer.

Check that one lead of timer motor is connected to terminal five of timer and the other lead is connected to neutral of 'Roast 'n Hold' switch.

If voltage at terminal 5 is correct and wiring is correct then the timer motor is faulty—replace timer.

If there is no power at terminal 5, check for power supply at terminal 4 of timer. If there is voltage at terminal 4 and not at terminal 6 with timer set, then timer switch is faulty—replace timer.

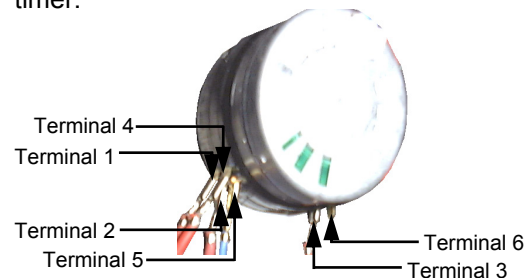

Figure 6.1.5

If terminal 4 voltage is correct, check relay at the base of the control housing behind control panel is latched ON. If relay is ON then check wiring.

If relay is not latched ON when 'Roast 'n Hold' switch illuminated then check the voltage across terminals 7 and 8 of relay coil (fig 6.1.3). If the voltage is correct but the relay is in the off position then the relay is faulty—replace.

If there is no voltage across 7 and 8 then check wiring.

#### 'Roast 'n Hold' switch faulty

Check if the switch latches. If the switch does not latch then the switch is faulty—replace.

With the switch latched, check voltage across terminal 1 to terminal 3 or 4. If there is no voltage then check for fault in wiring.

Check voltage across terminal 2 to terminal 3 or 4. If there is no voltage then switch is faulty—replace.

**NOTE:** When the switch is latched, it should illuminate if operating correctly.

---

### 6.1.15 NO HOLD INDICATOR

---

#### Indicator faulty

Check the voltage across the indicator terminals. If the voltage is correct then the indicator is faulty—replace.

If there is no voltage then check wiring.

#### Timer faulty

**NOTE:** Timer in 'HOLD' position (vertical) and 'Roast n Hold' switch on (illuminated).

Check the voltage at terminal three of timer, with timer in hold position. If the voltage is correct then check wiring.

If there is no voltage then check voltage at terminal one of timer. If there is voltage at terminal one, but no voltage at terminal three with timer in hold position then timer switch is faulty—replace.

---

### 6.1.16 HOLDING TEMPERATURE INCORRECT

---

#### Hold thermostat faulty

With the power switch on and illuminated, 'Roast 'n Hold' switch on and illuminated, and the roast (180 minute) timer set to hold, check that the hold indicator is illuminated.

With hold thermostat adjusted above oven temperature, check for output voltage at terminal 2 of hold thermostat. If there is no voltage and the hold thermostat will not switch on then the thermostat is faulty—replace.

If the voltage is correct but the burner is not working then check wiring and ignition box.

---

## 6.2 ACCESS

---

### 6.2.1 CONTROL PANEL

---

- 1) Undo the two screws at the bottom of the control panel.



Figure 6.2.1

- 2) The panel can now be removed.  
When closing the panel ensure wires and thermostat capillary tubes are clear of metal or other terminals.

---

### 6.2.2 SERVICE (SIDE) PANEL

---

- 1) Undo the four screws holding the panel.



Figure 6.2.2

- 2) Remove side panel.

---

### 6.2.3 BURNER ACCESS PANEL

---

- 1) Undo two screws holding the panel.
- 2) Remove panel.

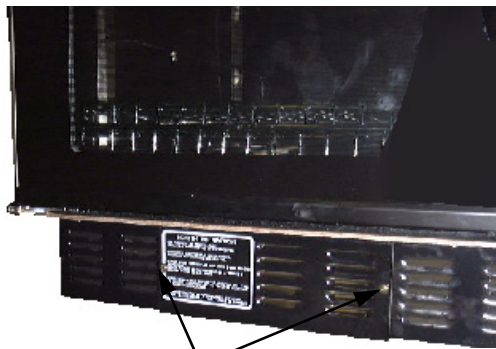

Two screws  
*Figure 6.2.3*

---

### 6.2.4 MANUAL ISOLATING VALVE / GAS CONTROL VALVE ACCESS PANEL

---

- 1) Undo two screws holding the panel.
- 2) Remove panel.



Two screws  
*Figure 6.2.4*

---

### 6.2.5 CONTROL PANEL—REAR

---

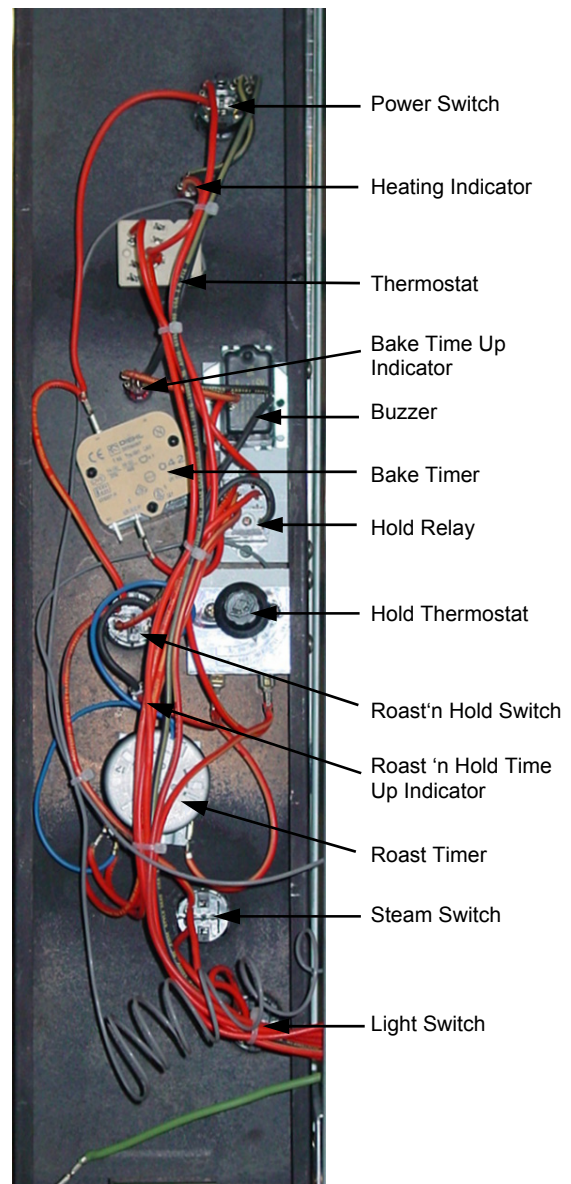

*Figure 6.2.5*

---

## 6.3 REPLACEMENT

---

### 6.3.1 LAMP BULB / GLASS

---

- 1) Unscrew lamp cover(s).



Figure 6.3.1

- 2) Unscrew bulb out of fitting.
- 3) Screw in replacement bulb.
- 4) Ensure seal fitted. Screw lamp cover into holder with baffle fitted (do not over tighten).

---

### 6.3.2 DOOR MICROSWITCH

---

- 1) Hinge down control panel (refer 6.2.1)
- 2) Remove two screws holding microswitch to bracket.

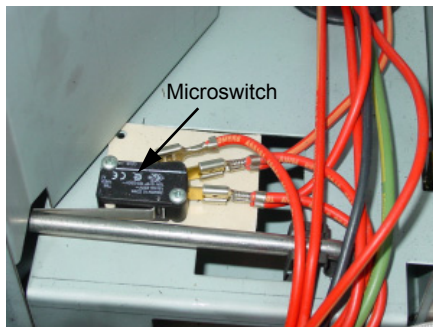

Figure 6.3.2

- 3) Transfer wires to new switch and re-assemble.
- 4) Adjust micro-switch (refer 6.4.2).

---

### 6.3.3 INDICATOR NEON LIGHT

---

- 1) With control panel open (refer 6.2.1) remove the wires from the back of the neon.

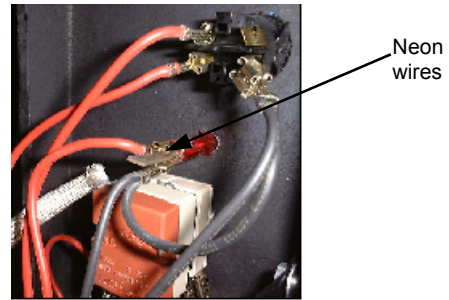

Figure 6.3.3

- 2) From back push neon through front of panel rotating clockwise.
- 3) Push new neon in from front of panel, and reconnect wires.

---

### 6.3.4 POWER / ROAST / LIGHTS / STEAM SWITCHES

---

- 1) With control panel open (refer 6.2.1) remove the wires from the back of the switch, noting their positions.

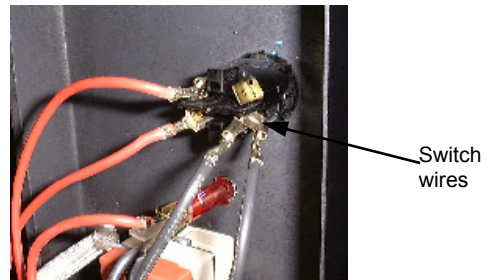

Figure 6.3.4

- 2) From back push switch through front of panel.
- 3) Push new switch in from front of panel, and reconnect wires.

---

### 6.3.5 BUZZER

---

- 1) Remove control panel (refer 6.2.1).
- 2) Remove two screws holding buzzer / relay bracket to control panel.

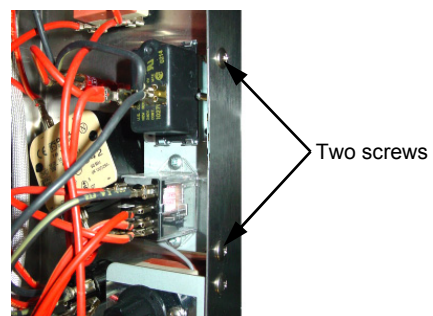

Figure 6.3.5

- 3) Withdraw and remove two screws holding buzzer to bracket.
- 4) Transfer wires to new buzzer.
- 5) Reassemble in reverse order.

### 6.3.6 HOLD RELAY

- 1) Open control panel (refer 6.2.1).
- 2) Remove two screws securing the relay to the buzzer / relay bracket on the control panel.

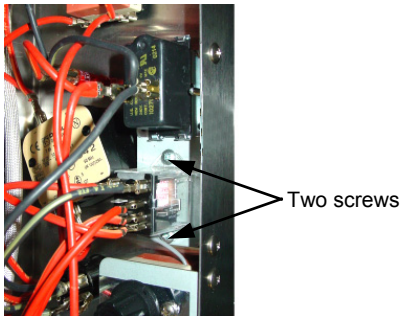

Figure 6.3.6

- 3) Withdraw and transfer wires to new relay.
- 4) Reassemble in reverse order.

### 6.3.7 BAKE TIMER

- 1) Remove bake timer knob by pulling it firmly away from control panel.
- 2) Open control panel (refer 6.2.1) and undo two screws securing timer.

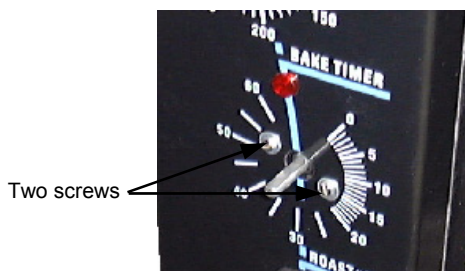

Figure 6.3.7

- 3) Transfer wires to new timer.
- 4) Withdraw old timer and insert new timer, securing with screws.
- 5) Replace knob.

### 6.3.8 ROAST TIMER

- 1) Remove roast timer knob by pulling it firmly away from control panel.
- 2) Open control panel (refer 6.2.1) and undo two screws securing timer.

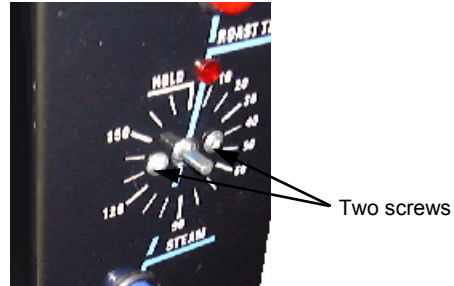

Figure 6.3.8

- 3) Transfer wires to new timer.
- 4) Withdraw old timer and insert new timer, securing with screws.
- 5) Replace knob.

### 6.3.9 THERMOSTAT

- 1) Pull knob off front of thermostat
- 2) Open control panel (refer 6.2.1) and undo two screws securing thermostat.

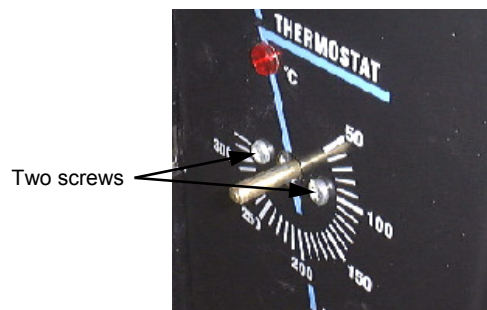

Figure 6.3.9

- 3) Transfer wires to new thermostat.
- 4) Open oven door, remove racks and fan baffle rack. Loosen two screws securing thermostat phial bracket.

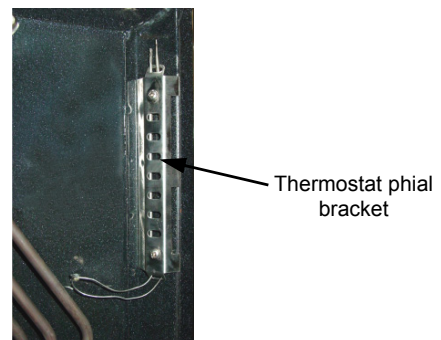

Figure 6.3.10

- 5) Withdraw old thermostat phial through side of oven. Note position in phial bracket.
- 6) Insert new thermostat.
- 7) Re-assemble in reverse order.

**NOTE:** Ensure that the thermostat phials are located in their correct positions. The main thermostat probe must be on the side closest to the door. The hold thermostat must be on the side closest to the fan.

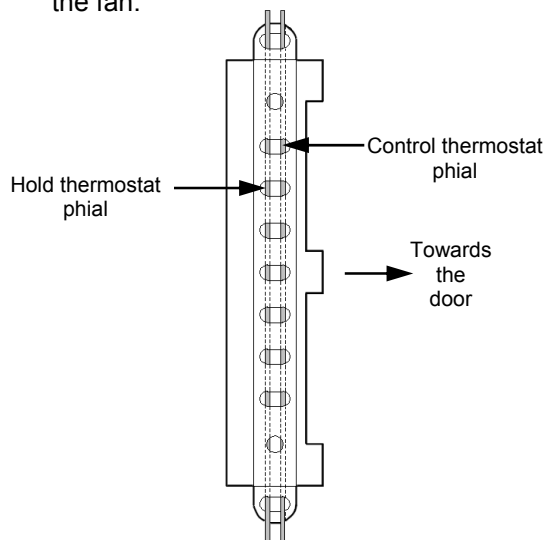

Figure 6.3.11

### 6.3.10 HOLD THERMOSTAT

- 1) Open control panel (refer 6.2.1) and undo two screws securing hold thermostat bracket.

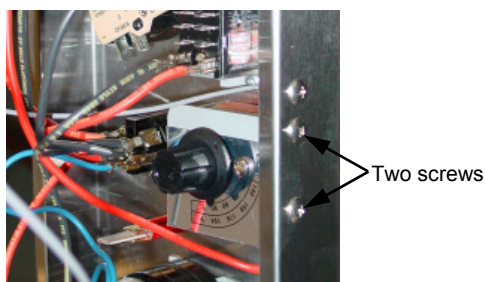

Figure 6.3.12

- 2) Remove the two screws securing the hold thermostat to the bracket, and then fit the new thermostat in its place.
- 3) Transfer wires to new thermostat.
- 3) Open oven door, remove racks and fan baffle rack. Loosen the thermostat phial bracket (refer figure 6.3.10).
- 4) Withdraw the old hold thermostat phial through the side of the oven. Note the position of the phial in the bracket.

- 5) Insert new thermostat phial.
- 6) Re-assemble in reverse order.

**NOTE:** Ensure that the thermostat phials are located in their correct positions. The main thermostat probe must be on the side closest to the door. The hold thermostat must be on the side closest to the fan (refer figure 6.3.11).

### 6.3.11 WATER SOLENOID

- 1) Ensure water supply is turned off.
- 2) To access the solenoid, remove the right hand service panel (refer 6.2.2)
- 3) Disconnect all water connections from the water solenoid.
- 4) Remove water solenoid from oven by removing two screws securing the water solenoid to its mounting bracket.

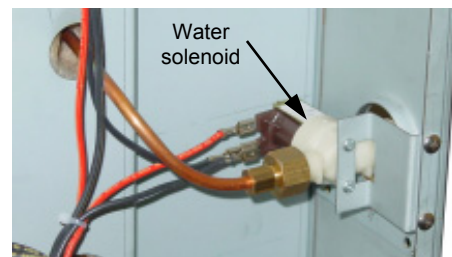

Figure 6.3.13

- 5) Carefully withdraw solenoid.
- 6) Replace or service solenoid as required.
- 7) To reinstall, reverse procedure.
- 8) Check water connections do not leak.

### 6.3.12 WATER SOLENOID CLEANING

- 1) Disconnect water supply from the water solenoid.
- 2) Remove the sieve from the valve assembly by pulling firmly away from the assembly with a pair of pliers.



Figure 6.3.14

- 3) Clean the sieve, removing all dirt and grime.
- 4) Replace the sieve and reconnect the water supply.

### 6.3.13 SPRAY NOZZLE

- 1) Inside the oven remove the RH side fan baffle, then unscrew the spray nozzle.

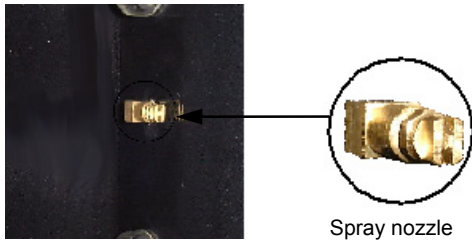

Figure 6.3.15

- 2) Clean or replace as required, ensuring debris free on re-assembly.
- 3) Ensure that the spray nozzle is installed in the vertical position.

### 6.3.14 FAN

- 1) With baffle removed undo the centre nut.  
**NOTE:** LH thread - Turn clockwise to loosen.

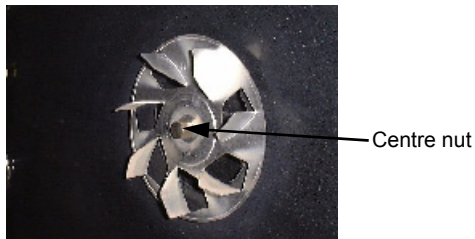

Figure 6.3.16

- 2) Replace and re-assemble in reverse order.

### 6.3.15 MOTOR

**Note:** When replacing a motor on a unit manufactured before February 2004 refer to appendix D.

- 1) Remove side service panel (refer 6.2.2)
- 2) Remove fan (refer 6.3.14) and then remove the wires that go to the motor.

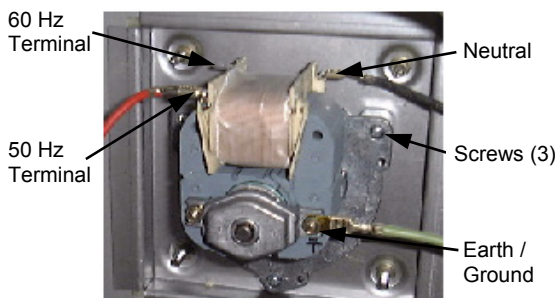

Figure 6.3.17

- 3) Undo the three screws holding the motor in place (from the outside) and remove motor.
- 4) Replace and re-assemble in reverse order.
- 5) Ensure wire connections are correct to the voltage supply—60 Hz / 50 Hz (fig 6.3.17)

### 6.3.16 OVERTEMP THERMOSTAT (UK UNITS ONLY)

- 1) Open control panel (refer 6.2.1)
- 2) To reset, firmly press reset button.

**⚠ WARNING: OVERTEMP IS LIVE. ISOLATE UNIT FROM THE POWER SUPPLY BEFORE RESETTING.**

- 3) To replace overtemp thermostat, remove the two screws securing overtemp to its bracket.

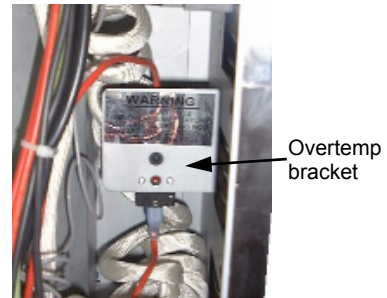

Figure 6.3.18

- 4) Remove wires from overtemp.

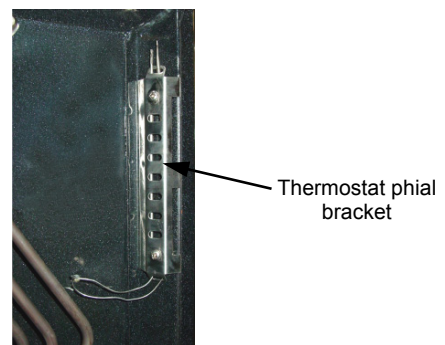

Figure 6.3.19

- 5) Open oven door, remove racks and fan baffle rack. Loosen two screws securing thermostat phial bracket.
- 6) Withdraw old overtemp thermostat phial through side of oven.
- 7) Remove fibreglass sleeving from old thermostat and fit to the replacement thermostat.
- 8) Replace overtemp and re-assemble in reverse order.

---

### 6.3.17 24 VOLT TRANSFORMER (USA / CANADA UNITS ONLY)

---

- 1) Remove the right hand panel (refer 6.2.2).
- 2) Remove the wires from the transformer, noting their positions.
- 3) Remove the two screws securing the transformer to the oven.

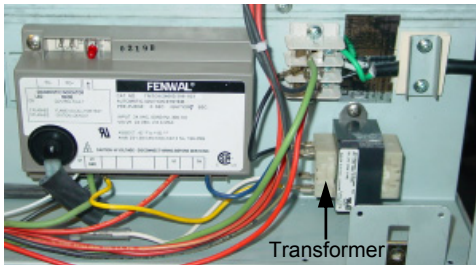

Figure 6.3.20

- 4) Replace transformer and re-assemble in reverse order.

---

### 6.3.18 IGNITION BOX

---

- 1) Remove the right hand side panel (refer 6.2.2).
- 2) Remove two screws securing the ignition box to the mounting plate.
- 3) Transfer wires from old ignition box to the new one.
- 4) Secure new ignition box to the oven with two screws.



Figure 6.3.21

**NOTE:** Ignition box may differ from that pictured here. Replacement procedure is however identical.

---

### 6.3.19 IGNITION ELECTRODES

---

- 1) Remove burner access panel (refer 6.2.4).
- 2) Remove the ignition electrode assembly by unscrewing two screws securing electrode bracket to the burner box, and withdrawing the electrode assembly.

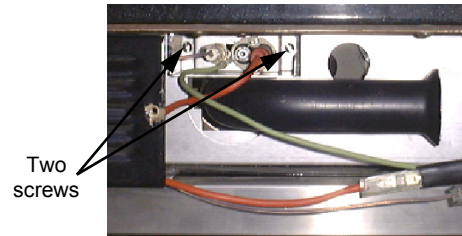

Figure 6.3.22

- 3) Disconnect wires (earth at sensor, flame sensor and spark electrode at lead connections) from electrodes requiring replacement.
- 4) Unscrew screws/nuts securing electrodes and remove from bracket.

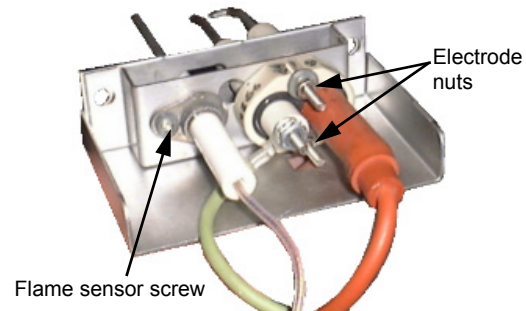

Figure 6.3.23

- 5) Replace and reassemble in reverse order.

**!** **IMPORTANT:** ENSURE ELECTRODE LEAD CONNECTIONS ARE FULLY INSULATED TO AVOID SHORTS IN THE HIGH TENSION CIRCUIT.

---

### 6.3.20 GAS CONTROL VALVE

---

- 1) Remove the manual gas control valve access panel and burner access panel (refer 6.2.4 and 6.2.5).
- 2) Close the manual gas valve.
- 3) Disconnect the mack union in the gas line next to the manual gas valve.

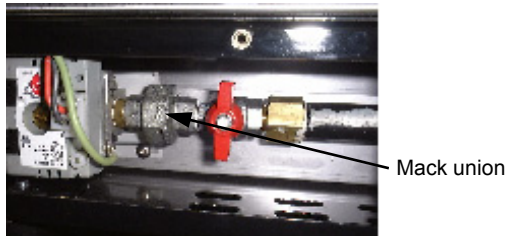

Figure 6.3.24

- 4) Unscrew and remove the burner injector from the burner mouth at the oven front.

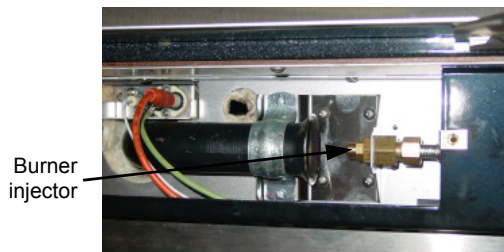

Figure 6.3.25

- 5) Remove the two screws securing the gas valve mounting bracket to the burner box panels.
- 6) Disconnect the three leads from the gas control valve.
- 7) Remove the gas valve and connected piping by drawing out through the side service panel.
- 8) Replace and reassemble in reverse order.

---

### 6.3.21 BURNER INJECTOR

---

- 1) Remove burner access panel (refer 6.2.4).
- 2) Remove injector from burner throat.

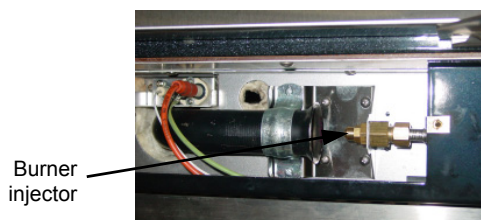

Figure 6.3.26

- 3) Clean or replace injector as required.  
Re-assemble in reverse order.

---

### 6.3.22 BURNER

---

- 1) Remove burner access panel (refer 6.2.4).
- 2) Remove ignition electrode assembly (refer 6.3.17)
- 3) Remove the saddle clamp securing the burner to the oven.

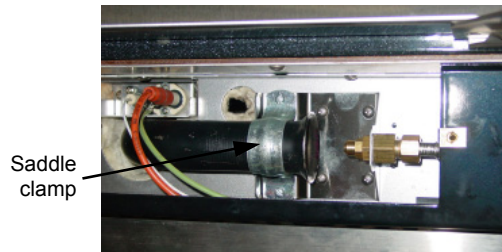

Figure 6.3.27

- 4) Burner can now be withdrawn from the oven. Inspect / replace and re-assemble in reverse order.

---

### 6.3.23 OUTER GLASS

---

- 1) Open door
- 2) Loosen the two screws securing the bottom pivot whilst supporting the door. The pivot can now be lowered, and the door removed from the oven.

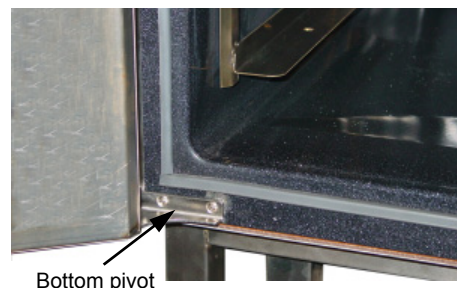

Figure 6.3.28

- 3) Remove screws securing door handle, and remove the handle from the door assembly.

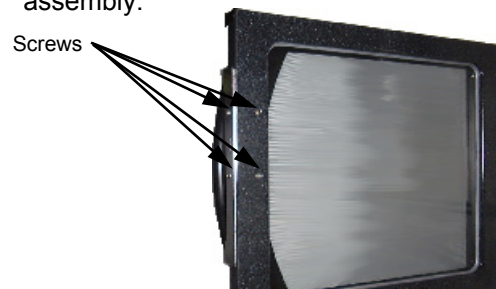

Figure 6.3.29

- 4) Remove four screws in top trim and four screws in bottom trim of door, and remove trim panels.

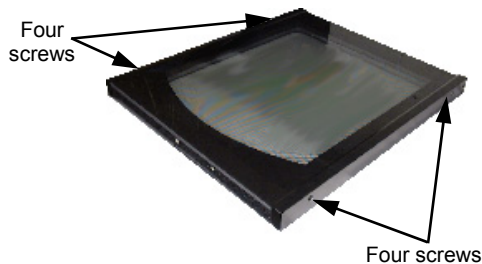

Figure 6.3.30

- 5) Lift outer glass away from door.
- 6) To replace, ensure that the two silicone rubber seals are in place on the left hand and right hand side of the door frame. Clean the inside of the glass and refit it, ensuring that the silicone rubber seals cover the outer edges of the glass. Refit the trim panels.

### 6.3.24 INNER GLASS

- 1) Remove the outer glass (refer 6.3.23). Uncrimp the retaining lugs of the window spacer and remove the spacer and glass.

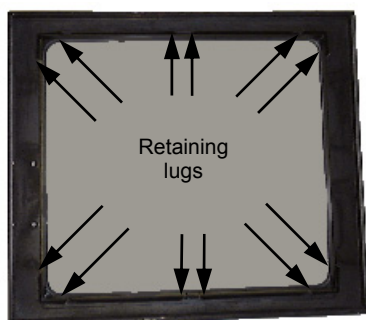

Figure 6.3.31

- 2) To replace, ensure the silicone rubber seal has not been displaced. Clean the glass and refit it. Place the window spacer in position and crimp the retaining lugs over to hold the glass in place. Refit outer glass as above.

### 6.3.25 DOOR SEALS

- 1) Open oven door.
- 2) To remove, hold at their centre point and pull forward until they unclip
- 3) Refit new seals.

**NOTE:** Fit top and bottom seals first, with open side of the seal facing downwards. Fit side seals with open side facing outwards.

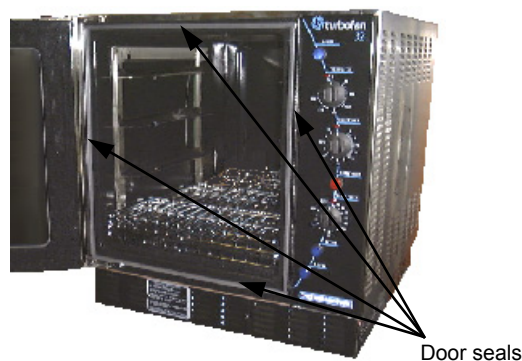

Figure 6.3.32

### 6.3.26 DOOR PIVOT BUSHES

- 1) Remove door as per steps one and two of section 6.3.23.
- 2) Remove the top and bottom pivot brackets (two screws).

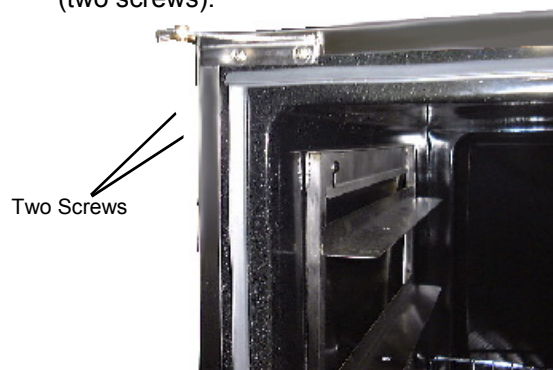

Figure 6.3.33

- 3) Door bushes can now be removed and replaced.



Figure 6.3.34

- 4) Reinstall door by reversing steps one to two of section 6.3.23.

### 6.3.27 STAINLESS STEEL DOOR - OUTER GLASS

- 1) Remove the door as per steps one and two of section 6.3.23.
- 2) Remove the top and bottom pivots (two screws each), and the door handle and roller catches (two screws top and bottom).

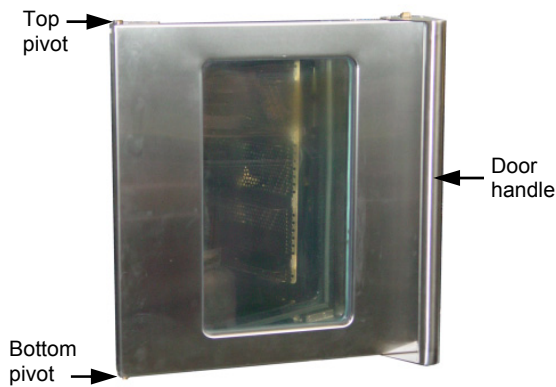

Figure 6.3.35

- 3) The stainless steel door outer can now be removed.
- 4) To replace the outer glass, simply remove and replace, taking care that the outer seals are positioned correctly around the glass edge.

Ensure when replacing that the side with the 'L' mark is inside the door (not on the front of the oven). This ensures the correct operation of the 'Low E' glass.

- 5) Reassemble in reverse order and refit door to oven.

### 6.3.28 STAINLESS STEEL DOOR - INNER GLASS

- 1) Remove the outer glass (refer 6.3.27).
- 2) Uncrimp the retaining angles and remove inner glass.

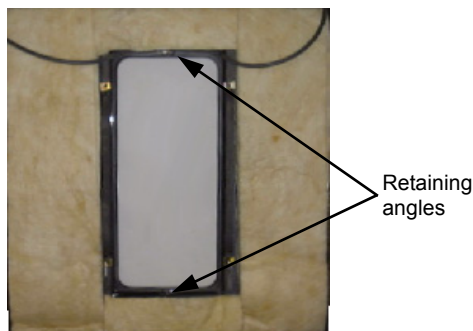

Figure 6.3.36

- 3) Replace with new glass.  
Ensure when replacing that the side with the 'L' mark is inside the door (not inside the oven). This ensures the correct operation of the 'Low E' glass.
- 4) Reassemble and refit door to the oven.

## 6.4 ADJUSTMENT / CALIBRATION

### 6.4.1 REGULATOR ADJUSTMENT

The appliance regulator is incorporated in the gas valve on these units. The regulator should be adjusted to set the burner gas pressure with the main burner running. To adjust:

- 1) Fit pressure gauge to pressure test point.
- 2) Remove screw cap on regulator of valve.
- 3) Turn on main burner and with main burner running, adjust regulator clockwise to increase pressure, and counter-clockwise to decrease pressure until correct setting is achieved.

Nat Gas (Not USA) 1.0kPa / 4.0" w.g / 10mbar

Nat Gas (USA only) 1.13kPa / 4.5" w.g

LPG/Prop/Butane 2.75kPa / 11.0" w.g / 35mbar

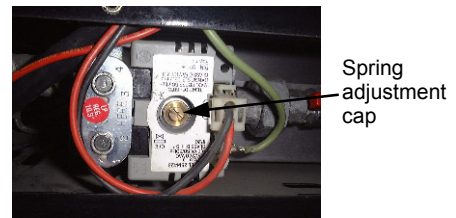

Figure 6.4.1

To change the gas type regulator spring:

- 1) Fully unscrew and remove the spring adjustment cap.
- 2) Withdraw spring and replace as required.
- 3) Refit adjustment cap and reset pressure.

#### **NOTE:**

LPG/Propane	Blue spring
Natural Gas	Green spring

### 6.4.2 THERMOSTAT CALIBRATION

**!** **IMPORTANT:** IF THE OVEN TEMPERATURE NEEDS TO BE INCREASED, ENSURE THAT THE THERMOSTAT IS IN THE 'OFF' POSITION BEFORE CARRYING OUT ADJUSTMENT. IF OVEN TEMPERATURE NEEDS TO BE DECREASED, ENSURE THERMOSTAT IS IN THE MAXIMUM TEMPERATURE POSITION BEFORE CARRYING OUT ANY ADJUSTMENT.

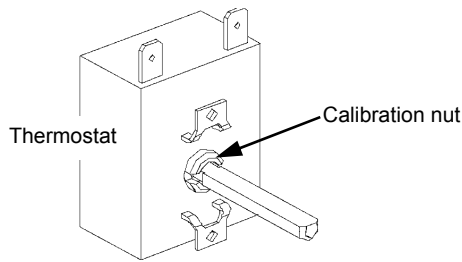

Figure 6.4.2

- 1) Remove thermostat knob by pulling it firmly away from control panel.
- 2) Adjust the calibration nut located at the base of the thermostat shaft.

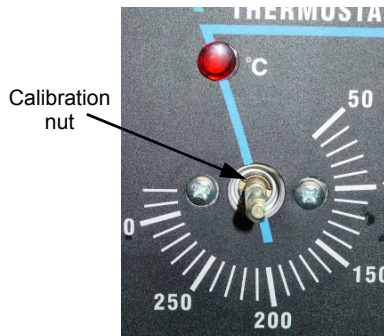

Figure 6.4.3

To increase oven temperature, turn the calibration nut anticlockwise.

To decrease oven temperature, turn the calibration nut clockwise.

Adjustment of the calibration nut by 1° angular will alter oven temperature by approximately 2°C (3.6°F).

- 3) Refit the knob to the thermostat.
- 4) Recheck the oven thermostat calibration.
- 5) Repeat procedure if necessary.

#### 6.4.3 CONFIRMING OVERTEMP CALIBRATION - UK UNITS ONLY

- 1) Place a digital thermometer inside the oven.
- 2) Set the thermostat to maximum setting.
- 3) When thermostat cycles off check oven temperature against dial setting. If overtemp has tripped (as indicated by power loss to unit) before oven has reached set temperature then the overtemp is out of calibration - replace, refer section 6.3.16.
- 4) If overtemp trips but oven temperature has exceeded 330°C, then the thermostat is out of calibration - re-calibrate - refer section 6.4.2.

#### 6.4.4 DOOR MICROWITCH ADJUSTMENT

- 1) Open oven door.
- 2) Open control panel (refer 6.2.1).
- 3) With fingers, bend actuator arm of microswitch so that switch operates when door is in closed position.

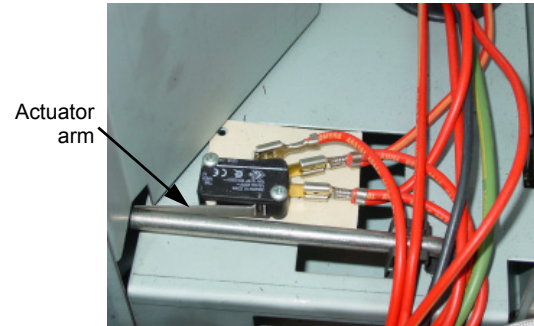

Figure 6.4.4

#### 6.4.5 REVERSING THE DOOR

If desired, a left hand hinged oven door can be changed to a right hand hinged door (or vice versa).

- 1) While supporting the door, undo the door hinges from the oven. Remove the door.
- 2) The bottom right door catch plate should now be transferred to the top left of the oven (a), and the top right door catch plate transferred to the bottom left of the oven (b).

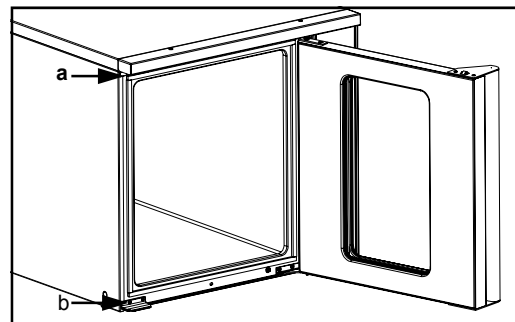

Figure 6.4.5

- 3) Secure the door hinges and oven door to the right hand side of the oven door opening.
- 4) If alignment of the door is necessary, the five screws along the bottom of the oven can be loosened, and the door moved a small amount to ensure that it is square with the oven. Tighten the screws when the correct door position is attained.

- 5) If necessary the roller catches can be removed from the door (after removing handle on stainless steel doors) to adjust height settings for correction of door catch operation.

#### 6.4.6 DOOR ROLLER CATCH ADJUSTMENT

- 1) Open the door.
- 2) Remove the two screws securing the roller catch to the door and withdraw the catch (on stainless steel doors the handle must first be removed).
- 3) Tighten or loosen the nuts on the catch assembly to adjust the height of the roller.

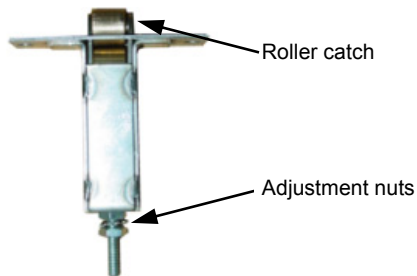

Figure 6.4.6

- 4) Refit catch to door and check operation. Adjust again if necessary.

#### 6.4.7 DOOR ALIGNMENT

- 1) Loosen the five screws along the bottom edge of the oven front.

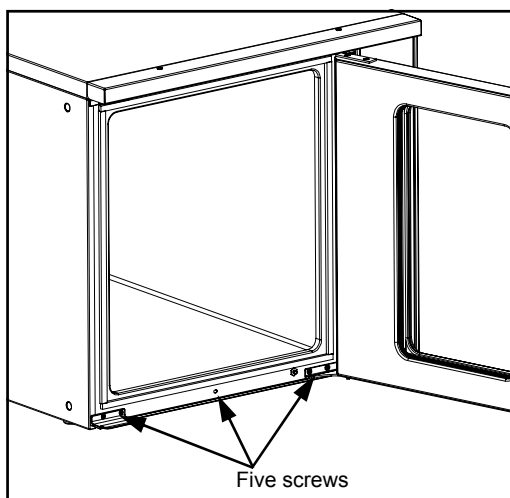

Figure 6.4.7

- 2) Adjust the door position to ensure that it is square with the oven. Tighten the screws.

#### 6.4.8 HOLD TEMPERATURE ADJUSTMENT

- 1) Open control panel (refer 6.2.1) to gain access to the hold thermostat (located inside the control panel).
- 2) The hold temperature of the oven can be adjusted by turning the hold thermostat dial to the desired hold temperature.

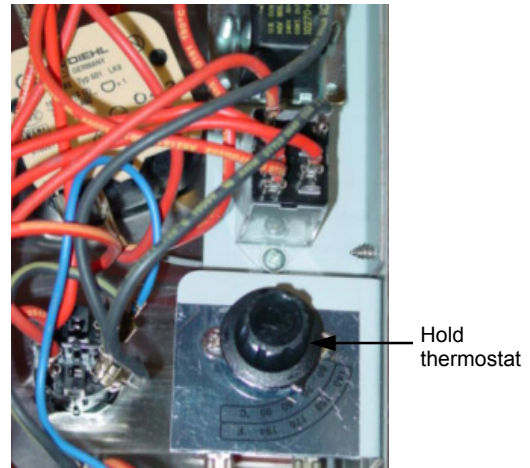

Figure 6.4.8

#### 6.4.9 60 MINUTE TIMER ZERO POSITION ADJUSTMENT

- 1) Remove 60 minute timer knob by pulling it firmly away from control panel.
- 2) Open control panel (refer 6.2.1). Loosen two screws on control panel holding 60 minute timer.

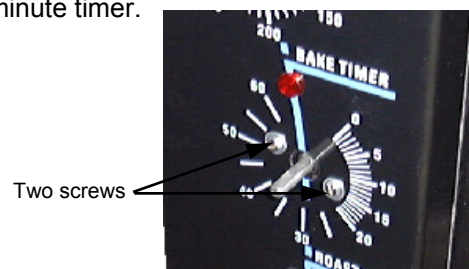

Figure 6.4.9

- 3) The timer can now be rotated a small amount as required to ensure that the buzzer sounds at the zero position.

### 6.4.10 BURNER INJECTOR ALIGNMENT

- 1) Remove burner access panel (refer 6.2.4).
- 2) To improve burner colour, an adjustment of the gas/air mixture can be made by adjusting the 'set' of the burner mixer tube injector holder bracket. Using suitable hand tools, raise or lower the injector alignment slightly and determine best position by viewing running burner colour change.
- 3) In most cases this adjustment would only be necessary after converting gas type or when burner has a significant lack of colour.

### 6.4.11 SPARK ELECTRODE ADJUSTMENT

The recommended gap settings for the ignition electrodes are given in the diagram below.

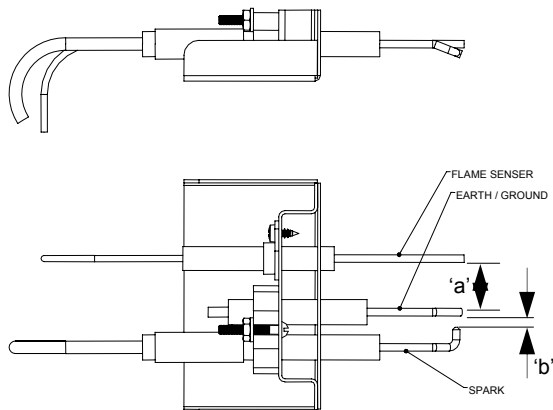

'a' 18.3mm (+0.5mm, -0mm)  
 $\frac{3}{4}$ " (+ $\frac{1}{64}$ " , -0")

'b' 4.5mm (+0.5mm, -0mm)  
 $\frac{3}{16}$ " (+ $\frac{1}{64}$ " , -0")

### 6.4.12 GAS TYPE CONVERSION

- 1) Remove side service panel to allow access to gas control valve.
- 2) Unscrew and remove screw cap from regulator incorporated in gas control.
- 3) Remove regulator spring from control. Replace with correct spring supplied with conversion kit.

LP Gas - Blue Spring Colour  
 Natural Gas - Green Spring Colour

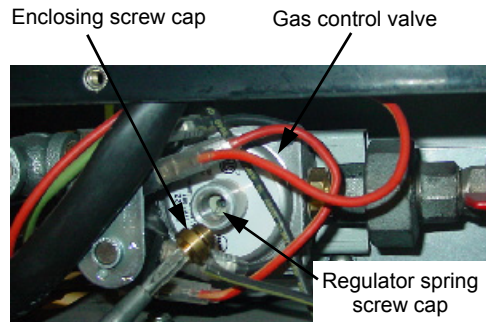

Figure 6.4.10

- 4) Remove injector access panel from bottom front of unit to allow servicing of injector.
- 5) Unscrew and remove injector and replace with appropriate item.

Natural Gas  $\varnothing$  2.70 mm  
 LP Gas  $\varnothing$  1.70 mm

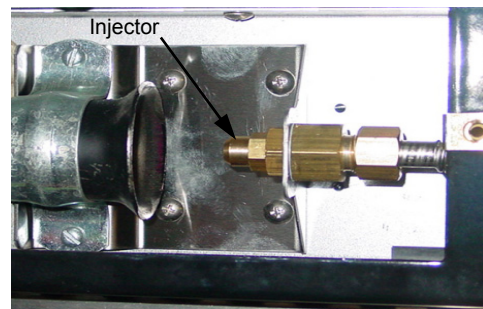

Figure 6.4.11

- 6) Connect gas and electrical supplies.
- 7) Operate oven and adjust regulator to achieve correct pressure at pressure test point (front RH corner).

Nat Gas 4.0" w.c. (1.00 kPa)  
 Nat Gas 4.5" w.c. (1.13 kPa) (110V only)  
 LP Gas 11.0" w.c. (2.75 kPa)  
 LP Gas 14.0" w.c. (3.50 kPa) (UK only)

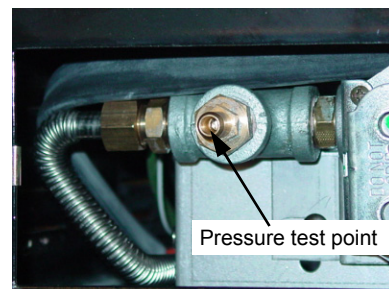
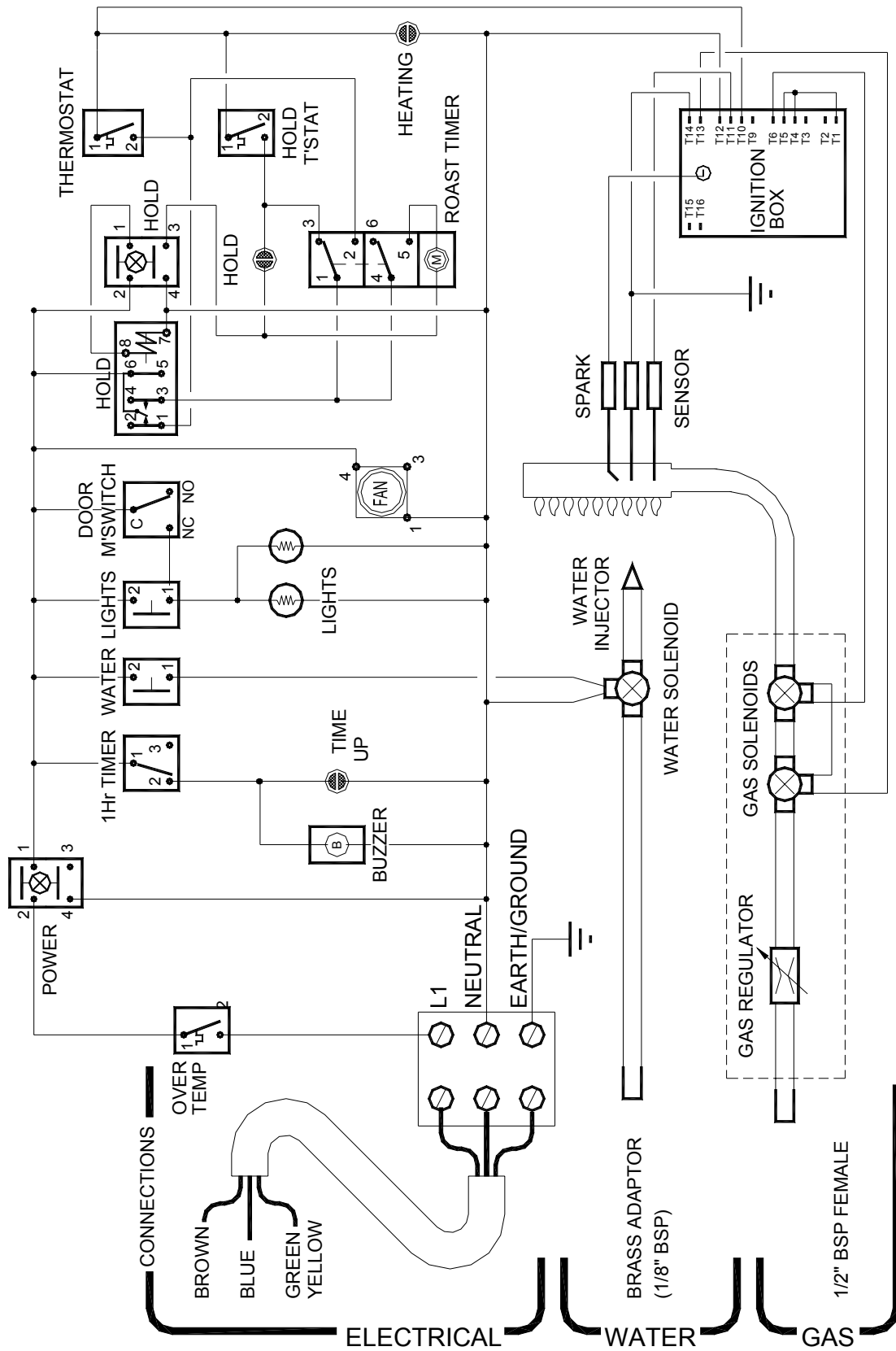

Figure 6.4.12

- 8) Conduct full leak test of the converted oven prior to placing it into operation.
- 9) Refit service panels.

# 7. CIRCUIT SCHEMATICS

## 7.1 220-240V 50Hz (UK ONLY)



## 7.2 100-120V 60Hz (USA, CANADA)

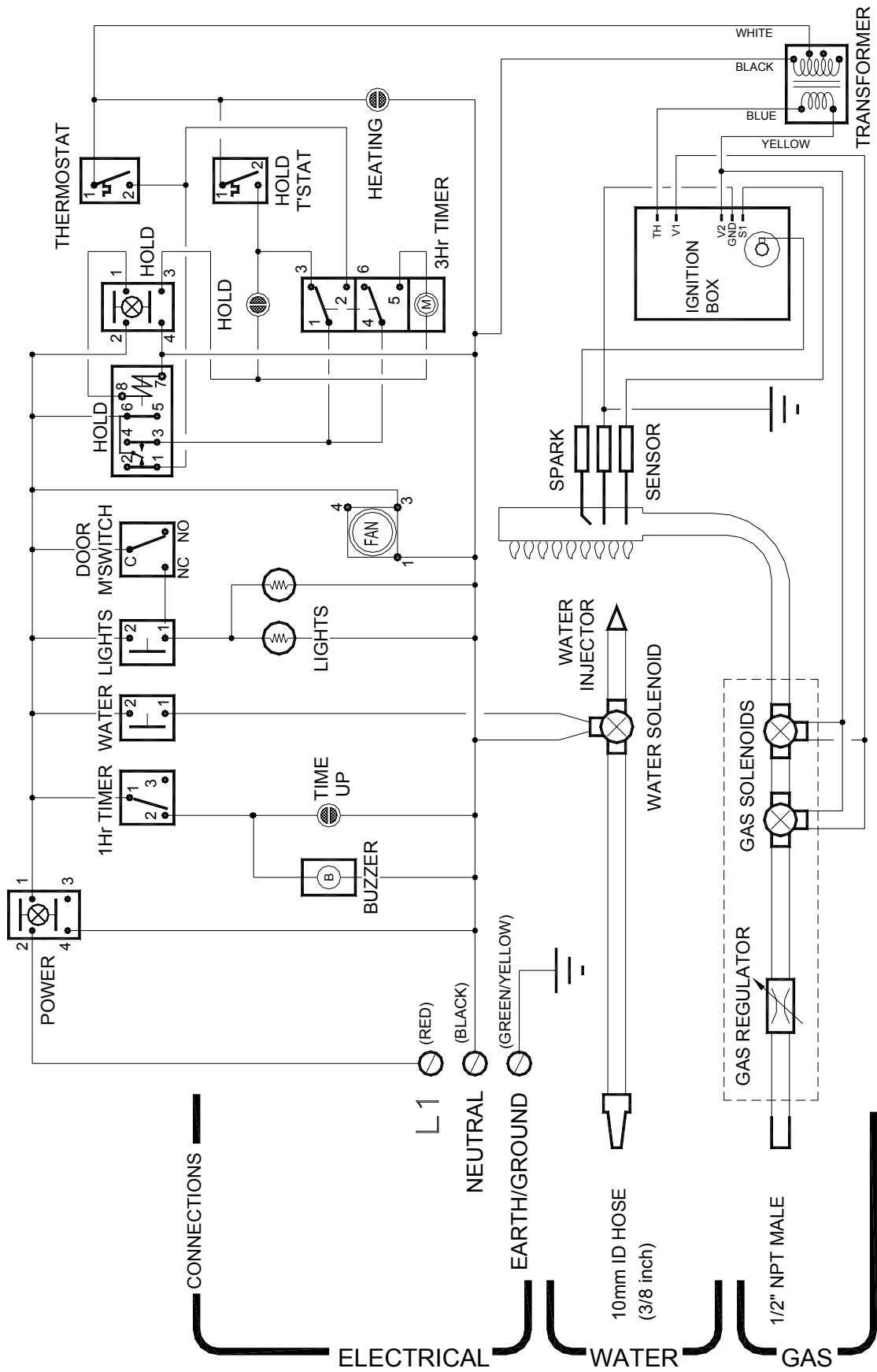

### 7.3 220-240V 50/60Hz (NOT UK)

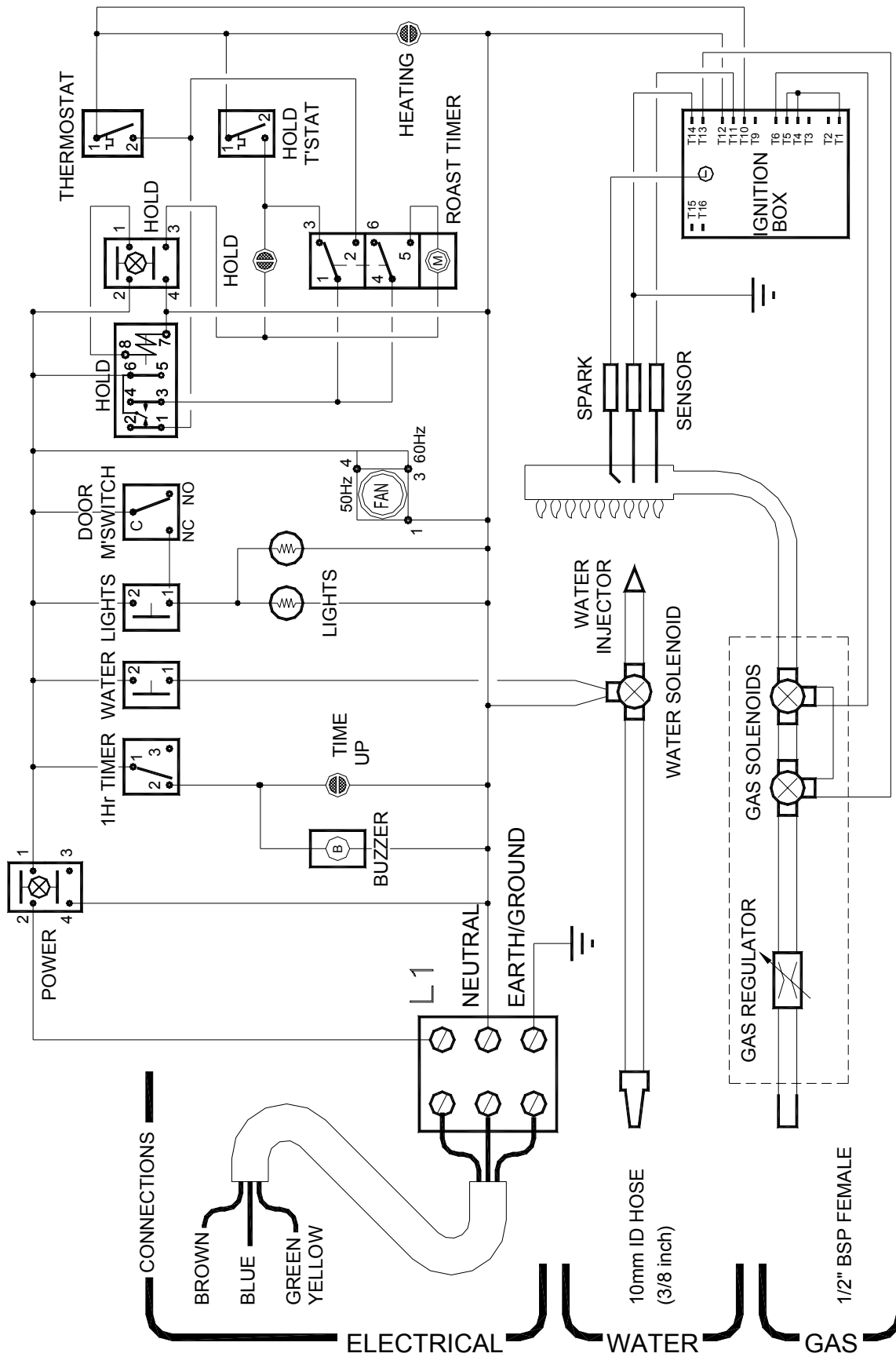

# 8. ELECTRICAL WIRING DIAGRAMS

## 8.1 220-240V 50Hz (UK ONLY)

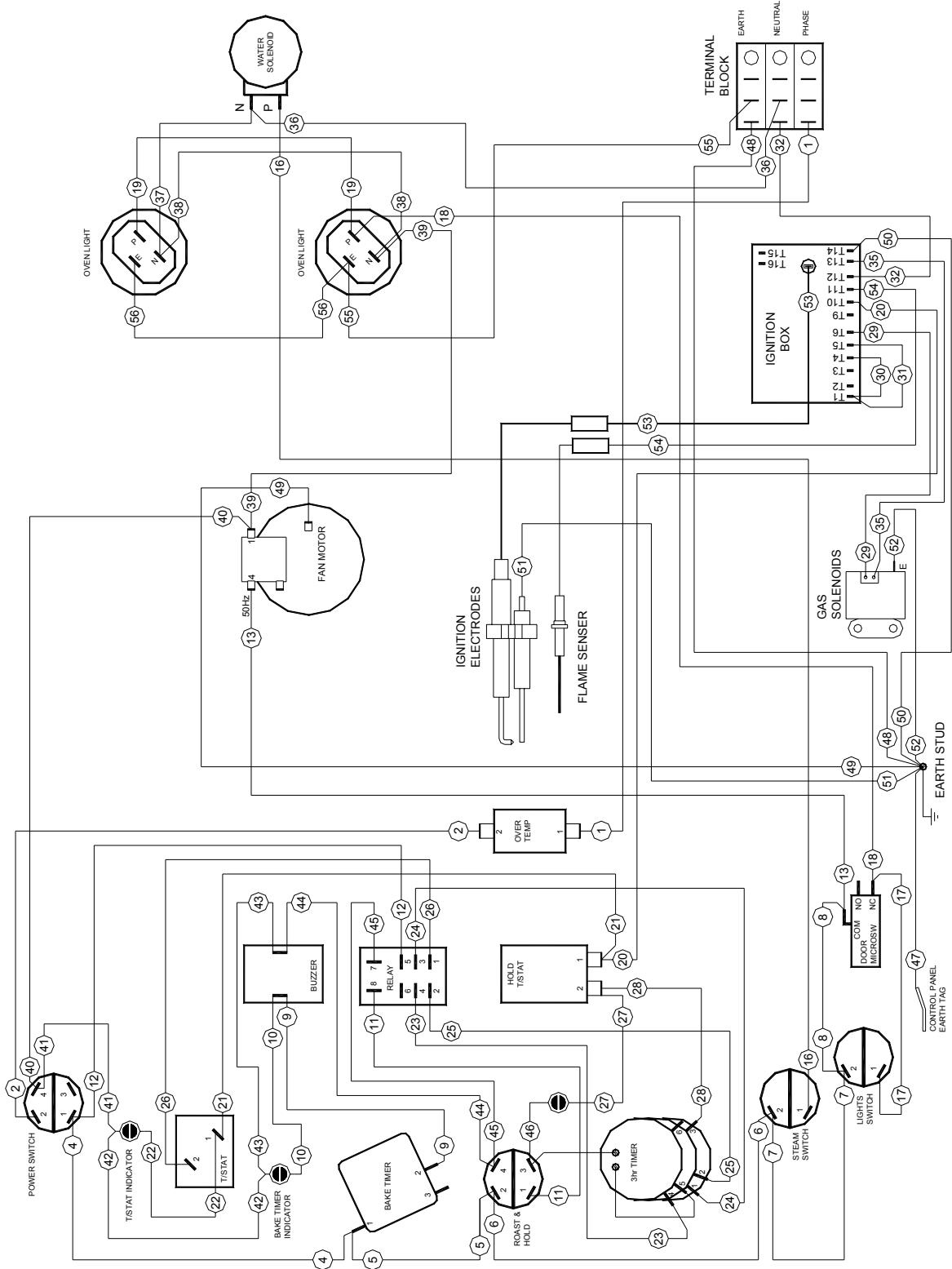



### 8.3 220-240V 50/60Hz (NOT UK)

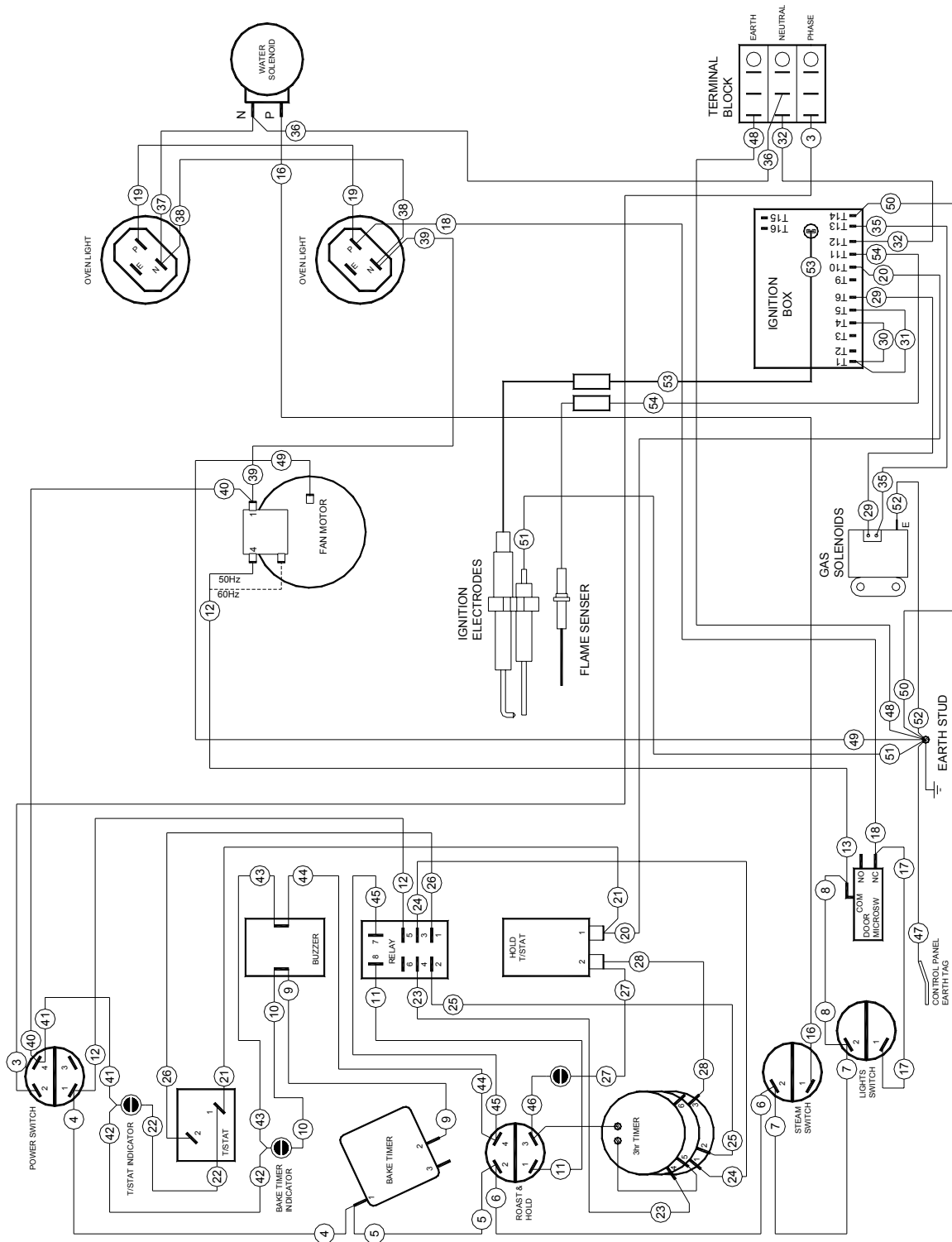

---

## 9. SPARE PARTS

### Controls

021473	Power Switch (220-240V)
021514	Power Switch (110V)
024774	Thermostat
020823	Knob - Thermostat / Bake Timer
020849	Neon Indicator (220-240V)
023857	Neon Indicator (110V)
011760	Bake Timer
011794	Buzzer (220-240V)
015822	Buzzer (110V)
021476	Roast 'n Hold Switch (220-240V)
021515	Roast 'n Hold Switch (110V)
011419	Roast 'n Hold Timer (220-240V, 50Hz)
011983	Roast 'n Hold Timer (220-240V, 60Hz)
015823	Roast 'n Hold Timer (110V, 60Hz)
021472	Roast 'n Hold Timer Knob
021534	Roast 'n Hold Relay (220-240V)
021535	Roast 'n Hold Relay (110V)
021474	Steam Switch
024773	Light Switch
018223	Hold Thermostat
024802	Microswitch
003002	Oven Lamp Glass
003434	Silk Gasket
013520	Oven Lamp Assembly - 40W Miniature Edison Screw (220-240V)
019482	Oven Lamp Assembly - 40W Miniature Edison Screw (110V)
013521	Oven Light Bulb (220-240V)
015825	Oven Light Bulb (110V)
019369K	Over-temp Thermostat Kit (UK Only)

### Motor

014672K	Fan Motor Kit (220-240V)
015821K	Fan Motor Kit (110V)
015598	Oven Fan

### Steam System

020851	Water Solenoid (240V)
021617	Water Solenoid (110V)
021057	Spray Nozzle Assembly
021526	Water Inlet Elbow
021527	Washer

---

## Ignition System

023025	Ignition Box (220-240V - SIT)
023024	Ignition Box (110V, USA/Canada - Fenwall)
019370	Gas Control Valve (220-240V)
015626	Gas Control Valve (25V)
022909	Complete Ignition Electrode Kit
025071	Flame sensor worked ( <b>From S/N 246144</b> )
022902	Flame Sensor Electrode ( <b>To S/N 246143</b> )
024127	Spark / Earth Electrodes

## Door

024784	Door Seal (Side)
024785	Door Seal (Top/Bottom)
020082	Top Hinge
020083	Bottom Hinge
024809	Roller Catch
017905	Door Bush
021468	Door Handle (G32M)
024599	Door Handle Bracket (G32M)
024844	Door Outer Glass (G32M)
002340	Door Inner Glass (G32M)
024713	Door Handle (G32MS)
023063	Door Glass (G32MS)

## Racks

015575	Oven Side Rack - LH
015656	Fan Baffle
015168	Oven Rack

## Gas Type Conversion Kits

025901	Natural and LPG Conversion Kit ( <b>From S/N 269436</b> )
015910	Natural Gas to LPG Conversion Kit ( <b>To S/N 269435</b> )
016403	LPG to Natural Gas Conversion Kit ( <b>To S/N 269435</b> )
019379	Natural Gas to Propane Gas Conversion Kit ( <b>UK Only</b> )
019378	Propane Gas to Natural Gas Conversion Kit ( <b>UK Only</b> )

## Stacking Kits

025739	Double Stacking Kit ( <b>From S/N 270991</b> )
025013	Double Stacking Kit ( <b>To S/N 270990</b> )
025861	Double Stacking Kit - G32M or MS on E89 ( <b>From S/N 270991</b> )

## 10. ACCESSORIES

**OVEN RACKS (PART NO 015168)**

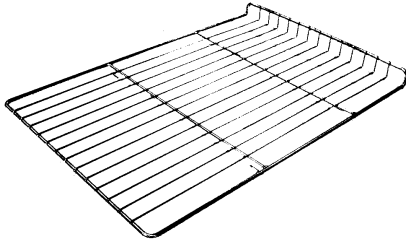

**COOKIE KIT—SIX TRAY OPTION  
(PART NOS 017156 & 017157)**



**A25 STAINLESS STEEL STAND**



**DOUBLE STACKING KIT - G32M or G32MS  
(PART NO 025739 - FROM S/N 270991)  
(PART NO 025013 - TO S/N 270990)**



# 11. PARTS DIAGRAMS

## 11.1 MAIN ASSEMBLY

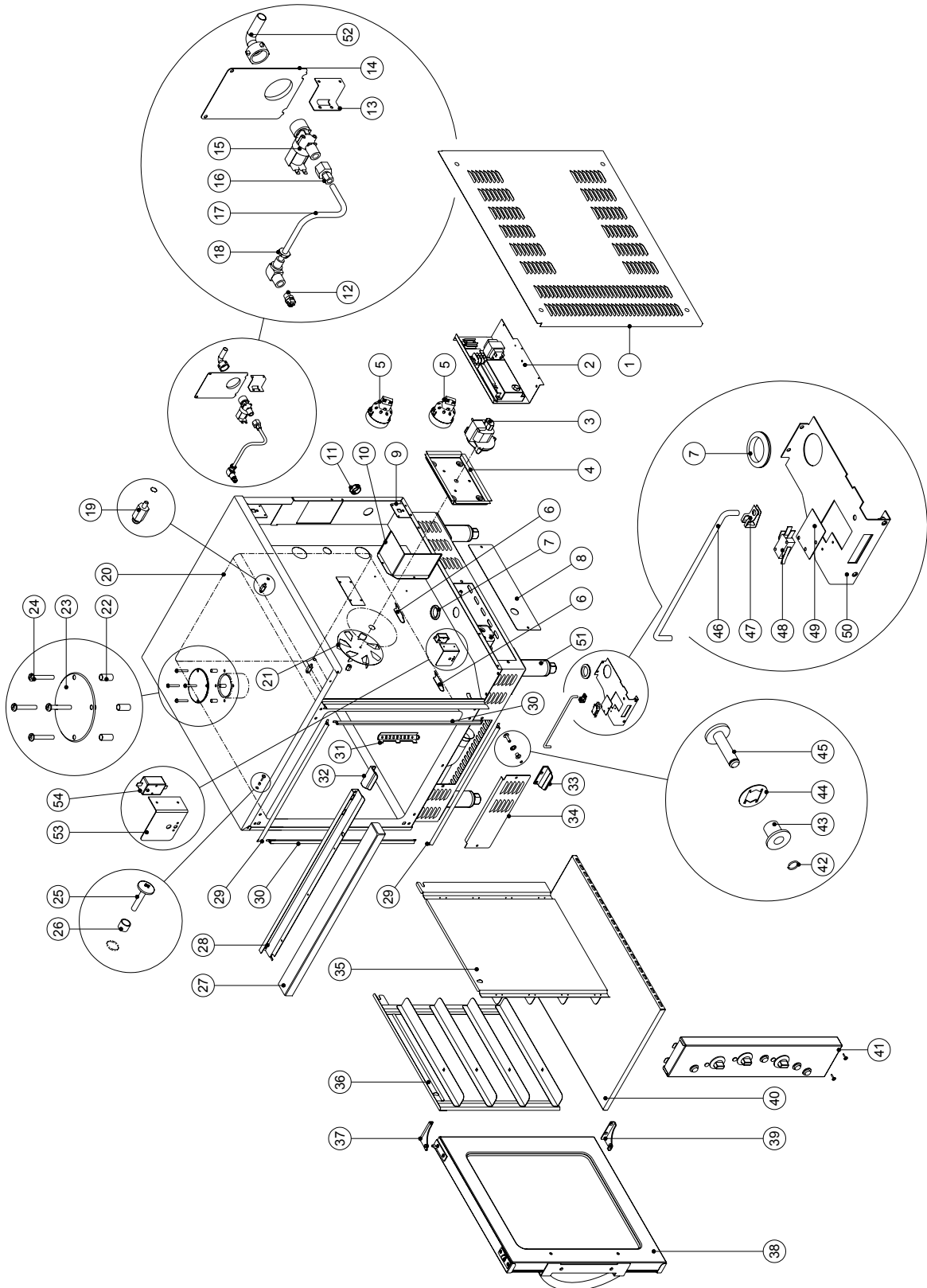

Pos	Part No.	Description
1	024683	SIDE COVER PANEL
2	-----	GEAR PLATE (REFER SECTION 11.4)
3	014672	FAN MOTOR (220-240V) – c/w HEAT INSULATION DISC
	015821	FAN MOTOR (110V) – c/w HEAT INSULATION DISC
4	014694	MOTOR MOUNTING PLATE
5	013520	OVEN LIGHT ASSEMBLY E14 (220-240V)
	013521	BULB 40W E14 (220-240V)
	023216	OVEN LIGHT ASSEMBLY E26 (110V)
	003434	SILK GASKET
	003002	LIGHT GLASS
6	024717	BAFFLE LOCATING BRACKET
7	010761	GROMMET $\varnothing 1\frac{1}{2}$ " RUBBER
8	004950	SIDE GAS SERVICE ACCESS PANEL
9	024689	SIDE COVER MOUNTING BRACKET
10	024852	HEAT DEFLECTOR
11	019239	SNAP BUSH 19mm
12	021057	SPRAY NOZZLE
13	024702	WATER SOLENOID MOUNTING BRACKET
14	021619	REAR SERVICE PANEL
15	020851	WATER SOLENOID (220-240V)
	021617	WATER SOLENOID (110V)
16	020869	CONNECTOR $\frac{3}{8}$ "F x $\frac{1}{4}$ "COMP
17	021058	WATER TUBE / ELBOW ASSEMBLY
18	013215	BACKNUT
19	014031	OVEN BAFFLE STUD
20	004925	OVEN LINER ENAMELLED
21	015598	FAN
22	016245	HOOD SPACER
23	016241	VENT HOOD PLATE
24	041401	SCREW M6 x 35 ST/ST
25	041405	SCREW $\frac{1}{2}$ " x $\frac{3}{16}$ "
26	003397	SPACER
27	004945	LINTEL ENAMELLED (G32M)
	024847	LINTEL ST/ST (G32MS)
28	024672	LINTEL SUPPORT
29	024785	TOP/BOTTOM DOOR SEAL
30	024784	LEFT/RIGHT DOOR SEAL
31	013974	PHIAL GUARD
32	024803	ROLLER STRIKE TOP
33	024804	ROLLER STRIKE BOTTOM
34	004949	INJECTOR ACCESS PANEL ENAMELLED
35	015656	FAN BAFFLE RH
36	015575	SIDE RACK LH
37	020082	TOP HINGE (ASSEMBLED WITH BUSH)
	017905	BUSH
38	-----	DOOR ASSEMBLY (REFER SECTION 11.5)
39	020083	BOTTOM HINGE (ASSEMBLED WITH BUSH)
	017905	BUSH
40	004397	RADIATION BAFFLE ENAMELLED
41	-----	CONTROL PANEL ASSEMBLY (REFER SECTION 11.2)
42	M021638	PIN CIRCLIP
43	M013610	BUSH
44	M044210	SPIRE CLIP
45	M021637	MICROSWITCH BUTTON
46	M024791	MICROSWITCH ROD
47	M017929	DAMPER ROD CLIP
48	M024802	MICROSWITCH
49	M013977	INSULATOR
50	M024584	MICROSWITCH BRACKET

---

51	230578	LEG 6" (FROM S/N 251942(USA ONLY) 252730 (NON USA)
	230577	LEG PLATE (NOT ILLUSTRATED) (FROM S/N 251942(USA ONLY) 252730 (NON USA)
	015274	LEG ASSEMBLY 6" (UP TO S/N 251941(USA ONLY) 252729 (NON USA)
	015275	LEG TUBE WA – PLATED (UP TO S/N 251941(USA ONLY) 252729(NON USA)
	010990	ADJUSTABLE FOOT
52	021526	WATER INLET ELBOW
	021527	WATER INLET WASHER
53	019380	OVERTEMP BRACKET (UK ONLY)
54	019369K	OVERTEMP THERMOSTAT KIT (UK ONLY) (UP TO S/N 262065) (KIT INCLUDES 025400 OVERTEMP)
	025400	OVERTEMP THERMOSTAT (UK ONLY) (FROM S/N 262066)

## 11.2 CONTROL PANEL ASSEMBLY

### 11.2.1 G32M CONTROL PANEL ASSEMBLY

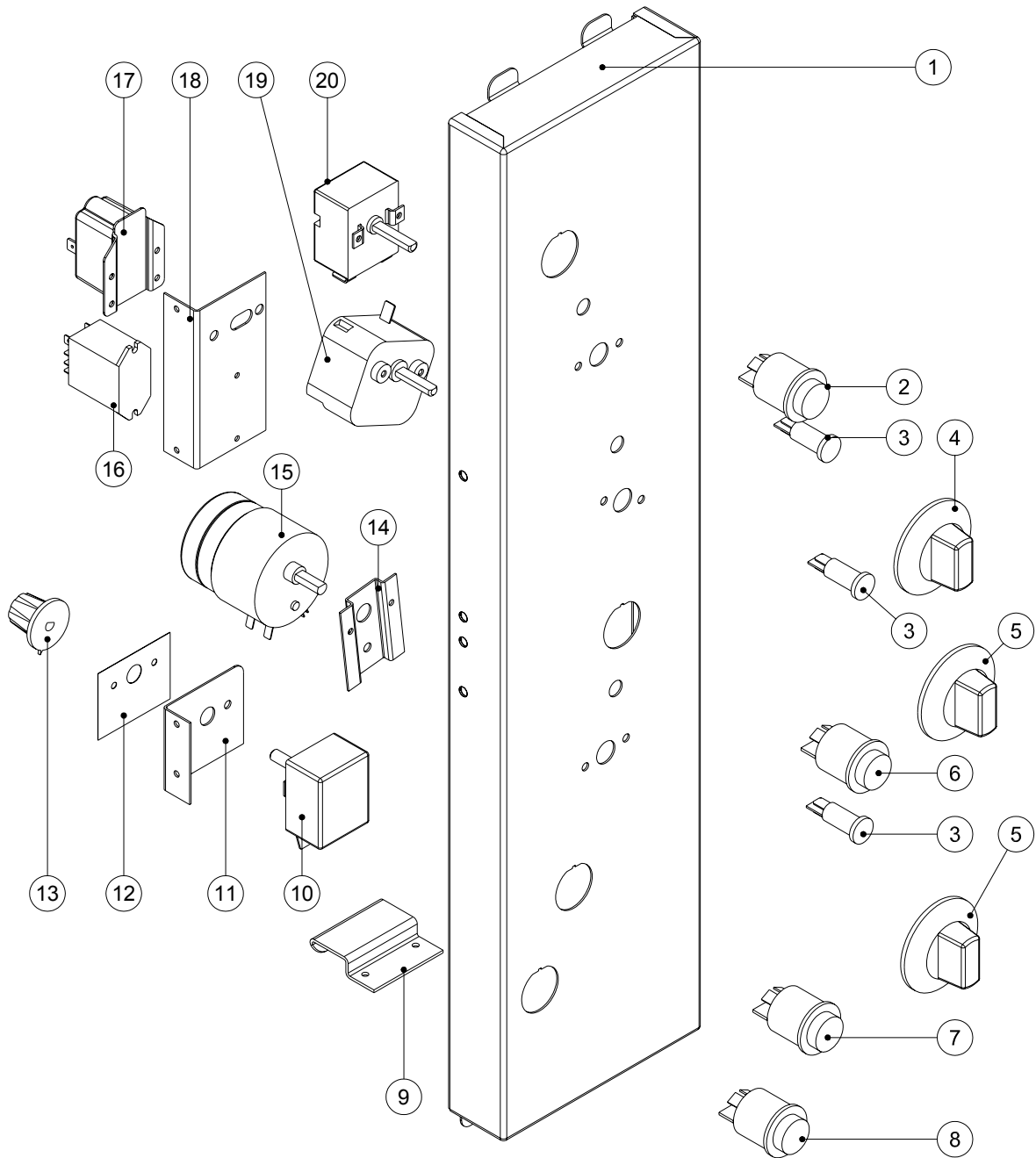

---

Pos	Part No.	Description
1	004955	CONTROL PANEL BAKBAR °C
	004956	CONTROL PANEL BLUE SEAL °C
2	021473	POWER SWITCH (240V)
	021514	POWER SWITCH (110V)
3	020849	INDICATOR LIGHT (240V)
	023857	INDICATOR LIGHT (110V)
4	021472	THERMOSTAT KNOB
5	020823	TIMER KNOB
6	021476	ROAST N HOLD SWITCH (240V)
	021515	ROAST N HOLD SWITCH (110V)
7	021474	STEAM SWITCH
8	024773	LIGHT SWITCH
9	024694	CONTROL PANEL HOOK
10	018223	HOLD THERMOSTAT
11	021538	HOLD STAT BRACKET
12	018209	HOLD STAT LABEL
13	018224	HOLD STAT KNOB
14	021442	TIMER MOUNTING PANEL
15	011419	3 HOUR TIMER (240V 50Hz)
	011983	3 HOUR TIMER (240V 60Hz)
	015823	3 HOUR TIMER (110V 60Hz)
16	021534	RELAY (240V)
	021535	RELAY (110V)
17	011794	BUZZER (240V)
	015822	BUZZER (110V)
18	024703	BUZZER/RELAY BRACKET
19	011760	60 MINUTE TIMER
20	024774	THERMOSTAT

## 11.2.2 G32MS CONTROL PANEL ASSEMBLY

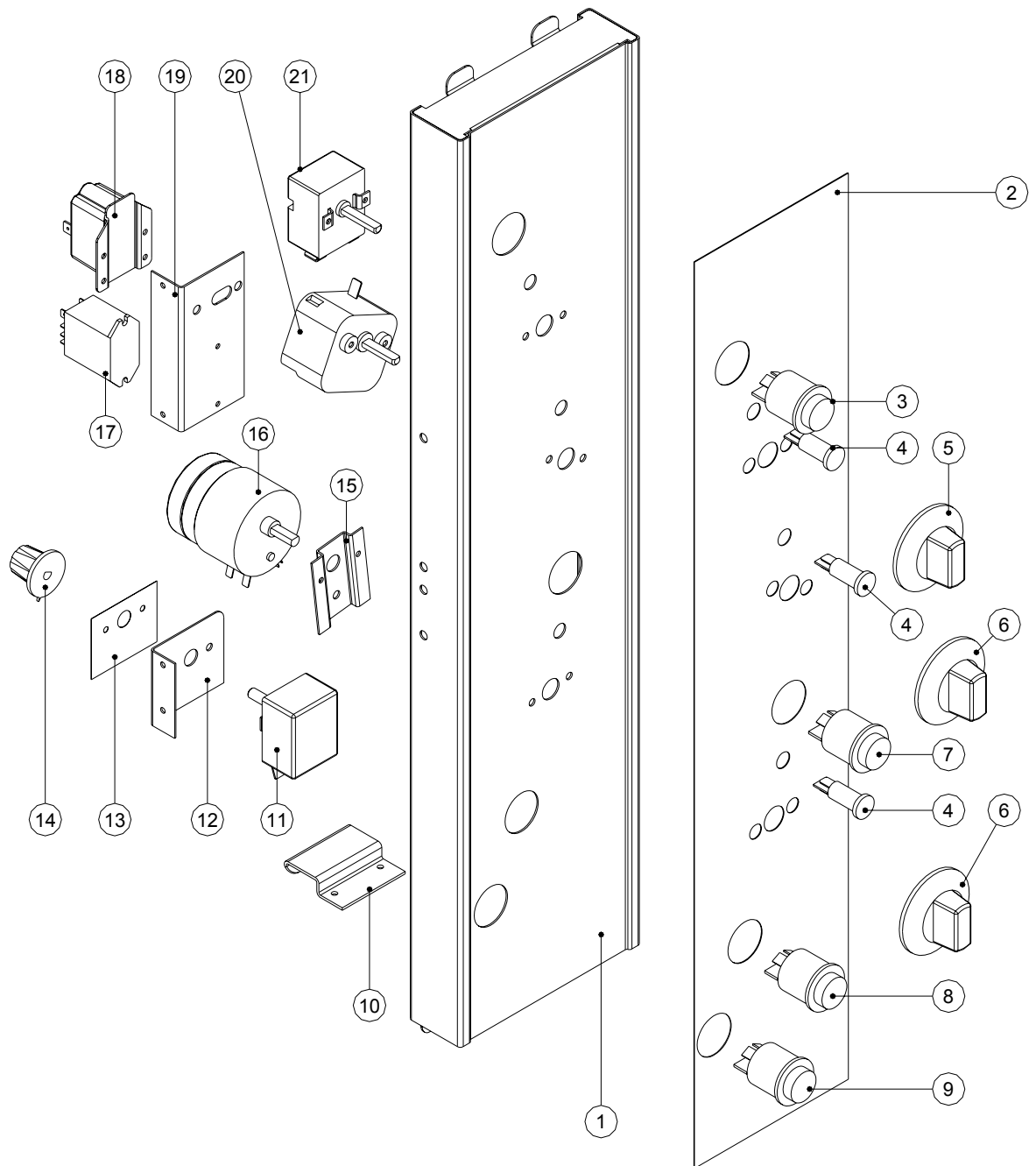

---

Pos	Part No.	Description
1	024805	CONTROL PANEL ST/ST
2	024778	OVERLAY BAKBAR °C
	024779	OVERLAY BLUE SEAL °C
	024777	OVERLAY MOFFAT °F
3	021473	POWER SWITCH (240V)
	021514	POWER SWITCH (110V)
4	020849	INDICATOR LIGHT (240V)
	023857	INDICATOR LIGHT (110V)
5	021472	THERMOSTAT KNOB
6	020823	TIMER KNOB
7	021476	ROAST N HOLD SWITCH (240V)
	021515	ROAST N HOLD SWITCH (110V)
8	021474	STEAM SWITCH
9	024773	LIGHT SWITCH
10	024694	CONTROL PANEL HOOK
11	018223	HOLD THERMOSTAT
12	021538	HOLD STAT BRACKET
13	018209	HOLD STAT LABEL
14	018224	HOLD STAT KNOB
15	021442	TIMER MOUNTING PANEL
16	011419	3 HOUR TIMER (240V 50Hz)
	011983	3 HOUR TIMER (240V 60Hz)
	015823	3 HOUR TIMER (110V 60Hz)
17	021534	RELAY (240V)
	021535	RELAY (110V)
18	011794	BUZZER (240V)
	015822	BUZZER (110V)
19	024703	BUZZER/RELAY BRACKET
20	011760	60 MINUTE TIMER
21	024774	THERMOSTAT 50-320°C

## 11.3 GAS ASSEMBLY

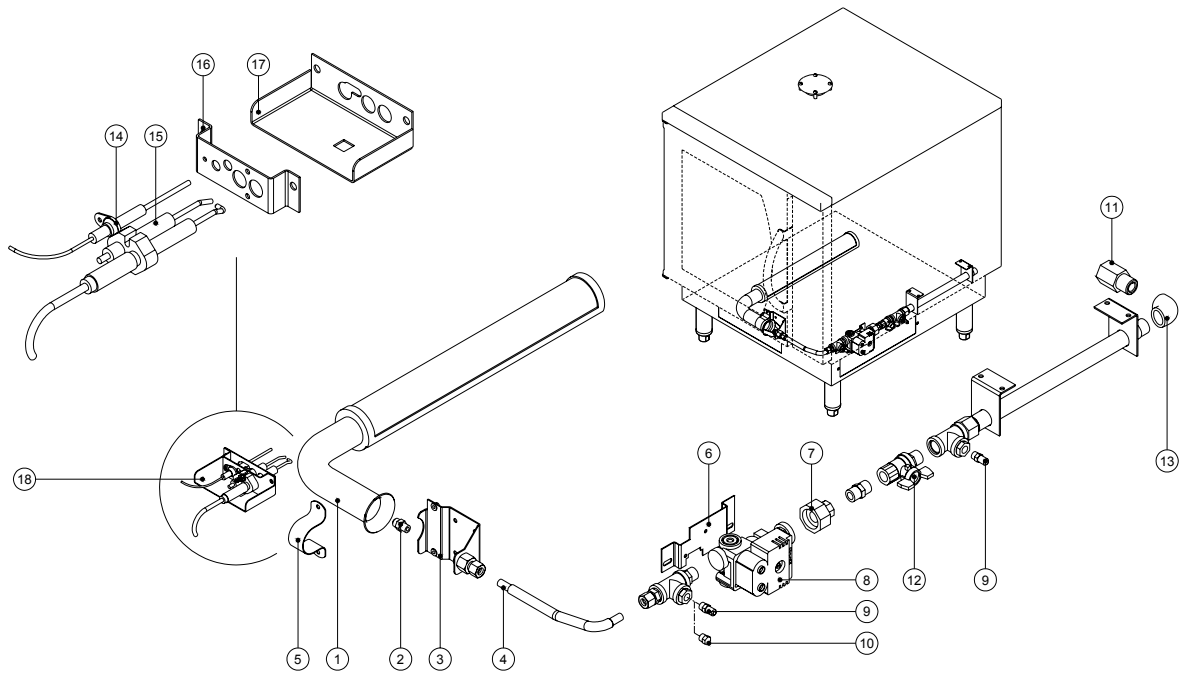

Pos	Part No.	Description
1	004952	BURNER
2	032280	INJECTOR 2.80mm (NAT) (FROM S/N 269436)
	032180	INJECTOR 1.80mm (LPG) (FROM S/N 269436)
	032270	INJECTOR 2.70mm (NAT) (TO S/N 269435)
	032170	INJECTOR 1.70mm (LPG) (TO S/N 269435)
	032260	INJECTOR 2.60mm (UK NAT ONLY)
	032155	INJECTOR 1.55mm (UK PROPANE ONLY)
3	SA1595	INJECTOR MOUNTING BRACKET ASSEMBLY
4	024156	FLEXTUBE 12" x 3/8" OD
5	024787	SADDLE 40mm
6	024765	GAS SOLENOID BRACKET
7	015313	MACK UNION
8	019370	GAS SOLENOID (240V)
	015626	GAS SOLENOID (110V UNITS ONLY)
9	019371	PRESSURE TEST POINT
10	015311	PLUG (110V USA/CANADA ONLY)
11	015314	ADAPTOR 1/2"NPT x 1/2"BSP (110V USA/CANADA ONLY)
12	025076	BALL VALVE 3/8" BSP (NON USA/CANADA)
	015310	BALL VALVE 3/8" BSP (USA/CANADA ONLY)
13	015176	ELBOW 1/2" BSP
14	025071	FLAME SENSOR WORKED (FROM S/N 246144)
	022902	FLAME SENSOR ELECTRODE (TO S/N 246143)
15	024127	SPARK ELECTRODES
16	025072	ELECTRODE MTG BRACKET (FROM S/N 246144)
	024106	ELECTRODE MOUNTING BRACKET (TO S/N 246143)
17	024105	IGNITION ELECTRODE BRACKET
18	022909	IGNITION ELECTRODE KIT COMPLETE ASSEMBLY

## 11.4 GEAR PLATE ASSEMBLY

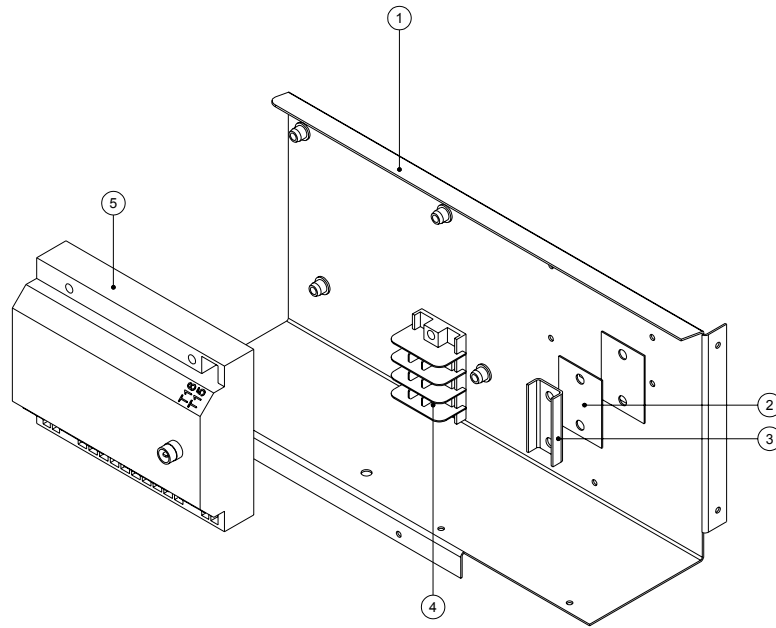

GEAR TRAY 240V

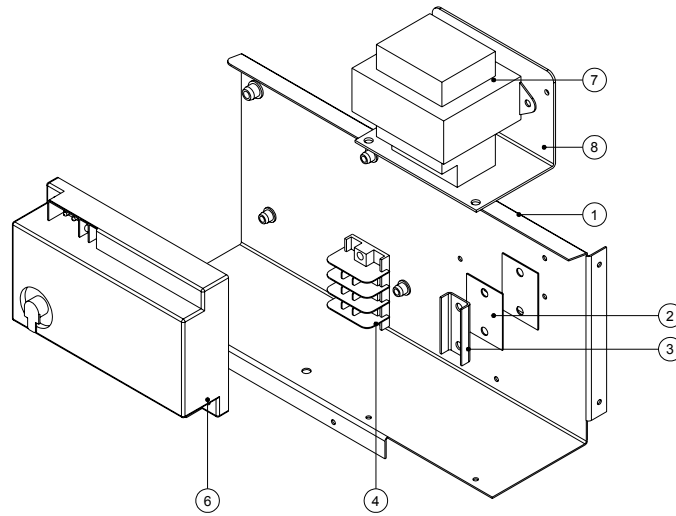

GEAR TRAY 110V

Pos	Part No.	Description
1	024853	GEAR TRAY
2	002441	INSULATOR
3	002138	CABLE CLAMP
4	013586	MAIN TERMINAL BLOCK
5	023025	IGNITION BOX SIT (240V UNITS ONLY)
6	023024	IGNITION BOX FENWAL (110V UNITS ONLY)
7	024851	TRANSFORMER (110V UNITS ONLY)(FROM S/N 242773)
	023373	TRANSFORMER (110V UNITS ONLY)(TO S/N 242772)
8	024800	TRANSFORMER BRACKET (110V UNITS ONLY)(TO S/N 242772)

## 11.5 DOOR ASSEMBLY

### 11.5.1 G32M GLASS DOOR ASSEMBLY

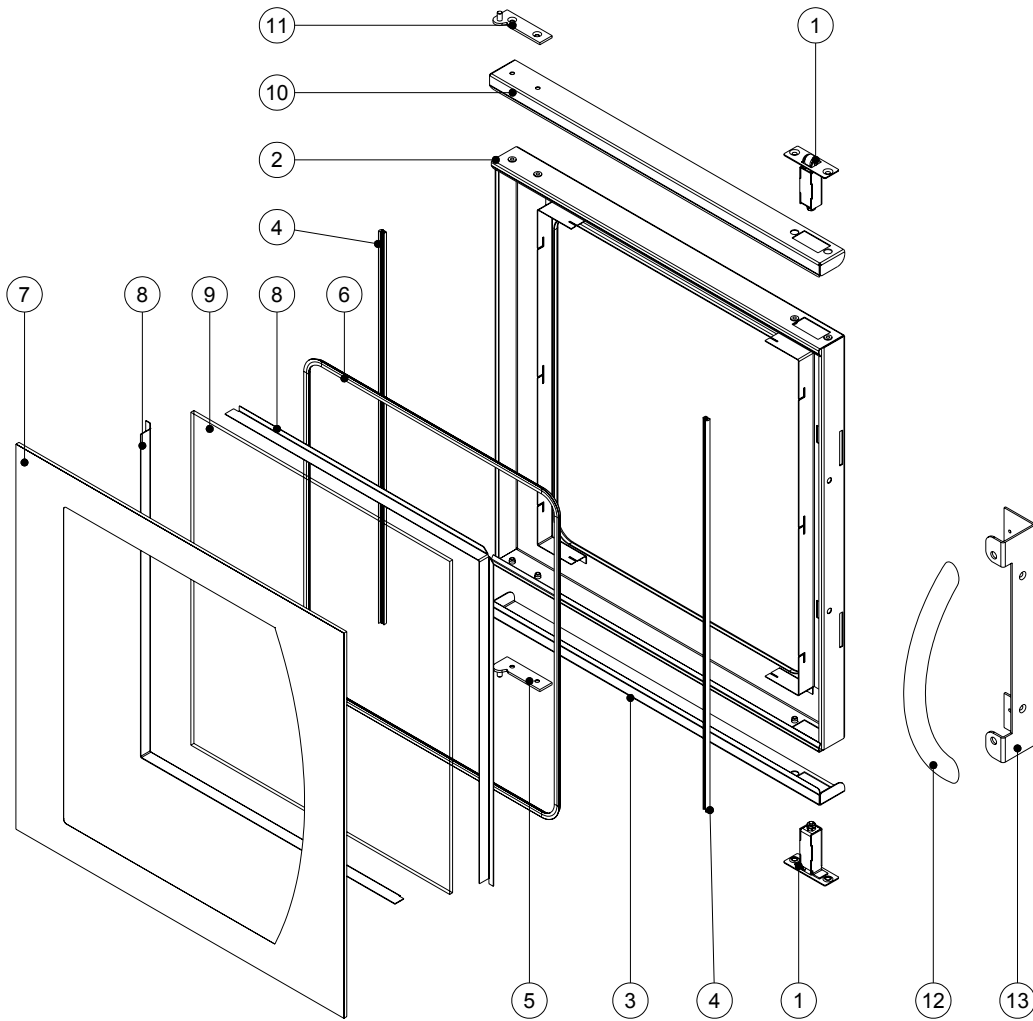

Pos	Part No.	Description
1	024809	ROLLER CATCH ASSEMBLY
2	004928	DOOR INNER ENAMELLED
3	024602	DOOR TRIM BOTTOM
4	090225	GLASS SEAL EXTRUSION (1.14m)
5	020083	BOTTOM HINGE ASSEMBLY
6	090201	GLASS SEAL EXTRUSION (1.74m)
7	024844	DOOR OUTER GLASS
8	004452	GLASS CLAMP ANGLE PAINTED
9	002340	DOOR INNER GLASS
10	024601	DOOR TRIM TOP
11	020082	TOP HINGE ASSEMBLY
12	021468	DOOR HANDLE
13	024599	DOOR HANDLE BRACKET
	SA1586	DOOR COMPLETE (EXCLUDING HANDLE & BRACKET)

## 11.5.2 G32MS STAINLESS STEEL DOOR ASSEMBLY

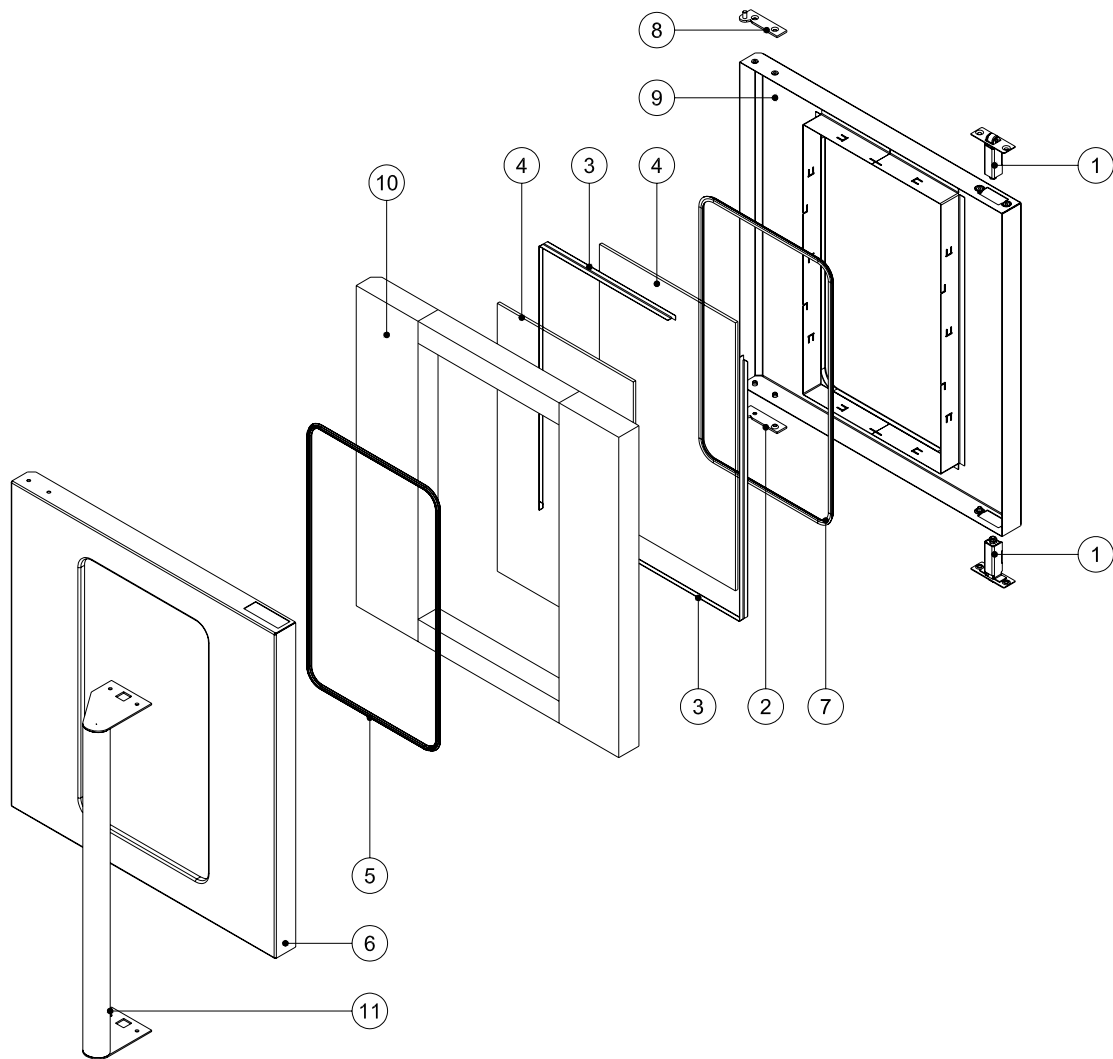

Pos	Part No.	Description
1	024809	ROLLER CATCH ASSEMBLY
2	020083	BOTTOM HINGE ASSEMBLY
3	024605	GLASS CLAMP ANGLE
4	023063	DOOR WINDOW GLASS
5	090201	GLASS SEAL EXTRUSION (1.44m)
6	024845	DOOR OUTER PANEL
7	090201	GLASS SEAL EXTRUSION (1.44m)
8	020082	TOP HINGE ASSEMBLY
9	004957	DOOR INNER (ENAMELLED)
10	-----	INSULATION
11	024713	DOOR HANDLE
	<b>SA1587</b>	<b>ST/ST DOOR COMPLETE</b>

---

## 12. SERVICE CONTACTS

### AUSTRALIA

#### VICTORIA - MOFFAT PTY

HEAD OFFICE AND MAIN WAREHOUSE  
740 Springvale Road  
Mulgrave VIC 3170  
Spare Parts Department

Tel (03) 9518 3888  
Fax (03) 9518 3838  
Free Call 1800 337 963  
Fax (03) 9518 3895

#### NEW SOUTH WALES - MOFFAT PTY

Unit 8/142 James Ruse Drive  
Rosehill NSW 2142  
Spare Parts

Free Call 1800 337 963  
Fax (03) 9518 3895

#### QUEENSLAND - MOFFAT PTY

30 Prosperity Place  
Geebung QLD 4034  
Spare Parts

Free Call 1800 337 963  
Fax (03) 9518 3895

#### SOUTH AUSTRALIA - MOFFAT PTY

28 Greenhill Rd  
Wayville SA 5034  
Spare Parts

Tel (08) 8274 2116  
Free Call 1800 337 963

#### WESTERN AUSTRALIA - MOFFAT PTY

PO Box 689  
Joondalup Business Centre WA 6027  
Spare Parts

Tel (08) 9305 8855  
Free Call 1800 337 963

**NATIONAL COVERAGE FOR 24 HOUR SERVICE OR MAINTENANCE DIAL  
FREE CALL 1800 622 216 (AUSTRALIA ONLY)**

### CANADA

SERVE CANADA  
22 Ashwarren Rd  
Downview  
Ontario M3J1Z5

Tel 416-631-0601  
Fax 416-631-0315

### NEW ZEALAND

#### CHRISTCHURCH - MOFFAT LTD

16 Osborne St  
PO Box 10-001  
Christchurch  
Spare Parts

Free Call 0800 Moffat  
(0800 663 328)

Tel (03) 389 1007  
Fax (03) 389 1276

#### AUCKLAND - MOFFAT LTD

4 Waipuna Road  
Mt Wellington  
Auckland  
Spare Parts

Tel (09) 574 3150  
Fax (09) 574 3159

Free Call 0800 Moffat  
(0800 663 328)

---

**UNITED KINGDOM**

BLUESEAL LTD  
Units 6-7 Mount St Business Park  
Nechells  
Birmingham B7 5QU  
England

Tel 0121-327 5575  
Fax 0121-327 9711

**UNITED STATES OF AMERICA**

MOFFAT INC.  
3765 Champion Blvd  
Winston-Salem  
NC27115

Tel 1-800-551 8795  
Fax 336 661 9546

**NATIONAL COVERAGE FOR SERVICE OR MAINTENANCE DIAL  
FREE CALL 1800 551 8795 (USA ONLY)**

---

## APPENDIX A. IGNITION BOX SPECIFICATIONS

### A.1 110 VOLT G32 MODELS, USA / CANADA

Make	Fenwal
Type	2460D-506-023
Case Colour	Grey
Voltage	24Vac (18-28Vac)
Ignition Trial Period	7 Seconds
Pre-purge	0 seconds (3.5 second delay on initial start)
Ignition Retries	2 (30 second purge)
Re-ignition Attempts	2
Spark Rate	60 Hz
Spark Voltage	25 kV
Lockout Indicator	At rear of casing 2 flashes indicates flame error. 3 flashes confirms lockout condition.
Minimum Flame Current	0.7 $\mu$ A

### A.2 220-240 VOLT G32 MODELS

#### All Models

Make	SIT
Type	501 EFD
Case Colour	Black
Voltage	230 Vac (220-240)
Ignition Trial Period	10 Seconds
Pre-purge	5 seconds
Ignition Retries	None
Re-ignition Attempts	1
Spark Rate	15 Hz
Spark Voltage	15 kV
Lockout Indicator	None
Minimum Flame Current	0.5 $\mu$ A

## APPENDIX B. DOUBLE STACKING KIT

(Kits manufactured from March 2004)

### Contents:

- 2 Side Cover (1)
- 1 Front Panel (2)
- 2 Side Support Rail (3)
- 1 Rear Panel (4)
- 1 Flue Duct (5)
- 1 Chimney (6)
- 1 Chimney Support (7)
- 31 Screws 8x3/8"
- 4 3/8" x 3/4" Bolts and Washers

**NOTE:** Food Grade RTV Silicone Sealant not supplied with kit

**CAUTION: ENSURE UNIT IS ISOLATED FROM ELECTRICAL / GAS SUPPLIES  
BEFORE SERVICING**

### Instructions:

#### Bottom Unit

**NOTE:** Refer to figure C. (overleaf) for general layout of stacking kit.

- 1) Remove the six middle screws from top rear of bottom unit.
- 2) Unscrew the vent hood plate from the bottom oven. Remove and discard the hood plate and spacer tubes. Replace the vent hood screws and completely screw in to secure the wrapper to the spacer tube.
- 3) Temporarily fit rear panel (4) and flue duct (5) to bottom unit (refer figure C), using two of the existing screw holes at top rear of unit.
- 4) Place the two side support rails (3) on the unit, ensure the large holes face up.
- 5) Fasten side support rails (3) to rear panel (4) two screws either side, ensure screws are started from rear panel (4) side with screw tip pointing out (refer figure A).
- 6) Remove plastic from front panel (2). Fasten to side support rails (3) (two screws either side), ensure screw tips point in (refer figure B).
- 7) Ensure stacking frame is square and mark the positions of the two bottom holes in the front panel (2) and the six holes for the flue duct (5).
- 8) Remove the two screws holding stacking frame and flue duct (5) to rear of bottom unit and remove frame.
- 9) Drill the eight holes ( $\text{Ø}3.5\text{mm}$  (1/8")) as per marked in step 7.
- 10) Apply a small amount of food grade RTV silicone sealant to the flue duct flanges (5) and screw to the bottom unit with six screws along the top (drilled), and two at the rear.
- 11) Re-fit stacking frame, fit three screws at rear and two screws at front into the holes drilled.

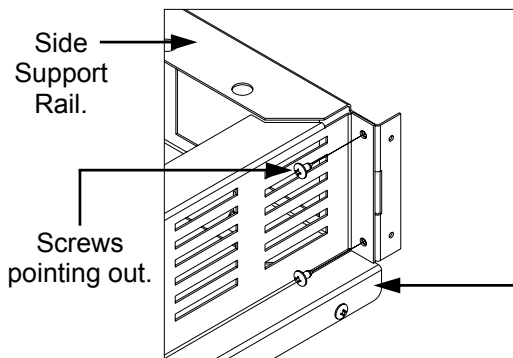

Figure A.

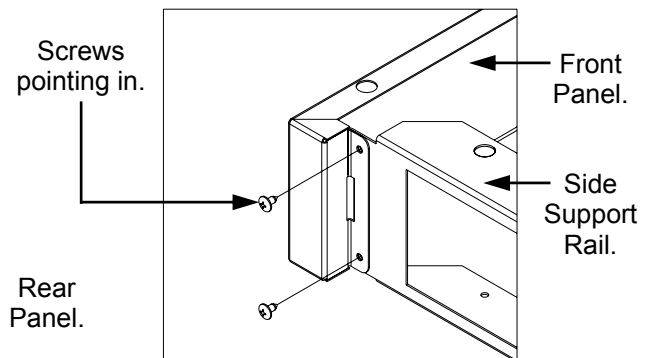

Figure B.

## Stacking

- 12) Remove legs from top unit, place on top of stacking frame, ensure front panel (2) is flush with sides of both units.
- 13) Reaching through the rectangular access holes in the side support rails (3) fasten the top unit to stacking frame with the four 3/8" bolts and washers, thread the bolt up into the foot holes of the top unit, ensure bolted through correct holes of the side support rails.
- 14) Remove plastic from side covers (1). Insert tab end into front panel (2) and fasten opposite end with two screws.
- 15) Position the chimney (6) on the rear of the units. Secure to the flue duct (5) and bottom unit with four screws. The holes in the bottom unit may need to be drilled,  $\varnothing 3.5\text{mm}$  ( $1/8"$ ).
- 16) Secure the top of the chimney (6) to the top unit with the chimney support (7) and two screws. These holes may need to be drilled,  $\varnothing 3.5\text{mm}$  ( $1/8"$ ).
- 17) Ensure that all screws on the stacking kit are tightened.

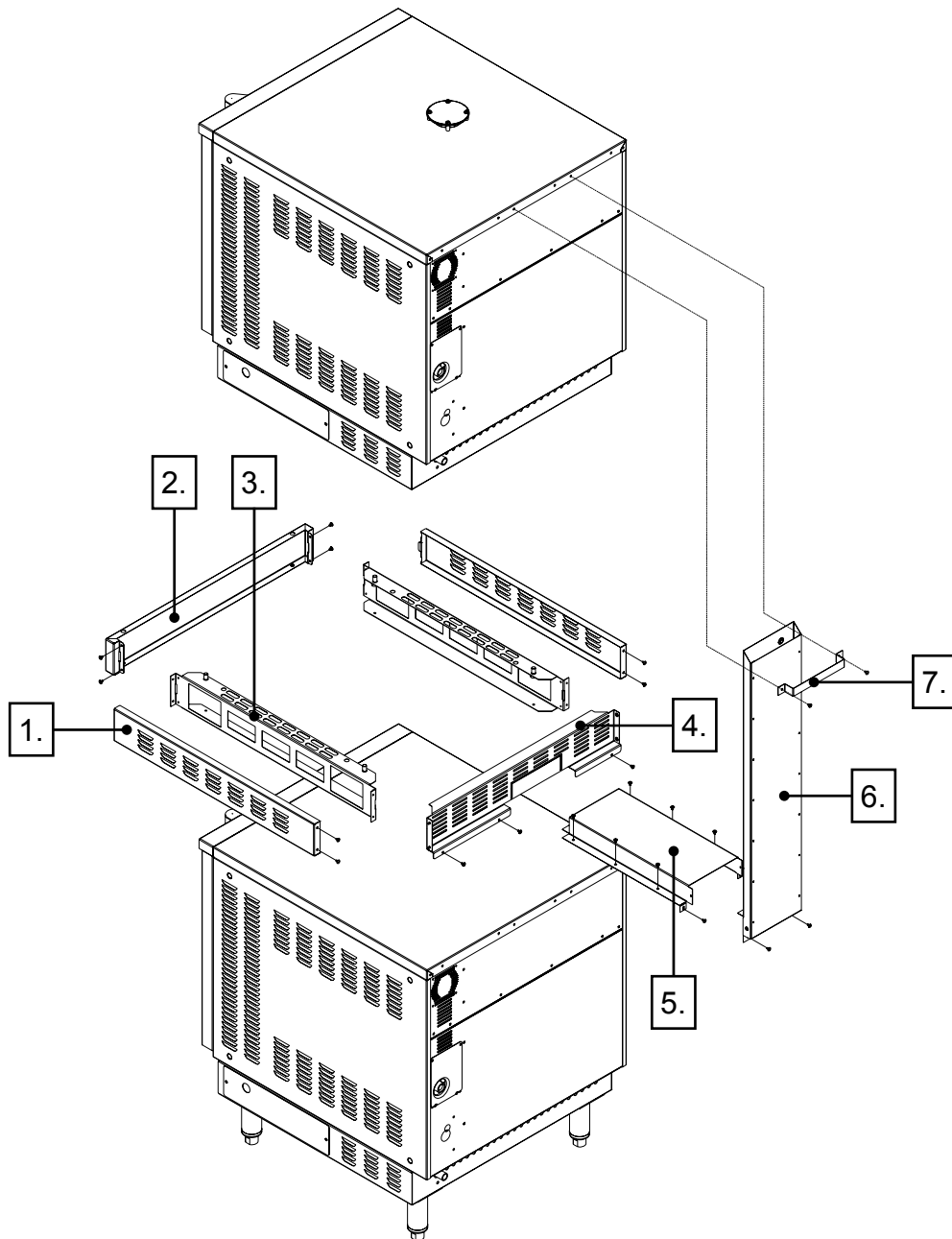

Figure C.

## APPENDIX C. DOUBLE STACKING KIT

(Kits manufactured before March 2004)

Kit contents (refer diagram overleaf):

Position	Description	Quantity
1	Shroud front	1
2	Shroud sides	2
3	Shroud rear	1
4	Chimney	1
5	Chimney support	1
6	Flue duct	1
7	$\frac{1}{2}$ " x 8A Pozi screws	20
8	$\frac{3}{4}$ " x $\frac{3}{16}$ " Phillips head screws	8
9	$\frac{5}{8}$ " x $\frac{3}{8}$ " Hex head screws	4
9	$\frac{3}{8}$ " Spring washers	4

**THE ELECTRICAL AND GAS SUPPLIES TO BOTH OVENS MUST BE DISCONNECTED PRIOR TO COMMENCEMENT**

### A. Bottom Unit - G32/M/MS

- Ensure that 6" (150mm) legs are fitted to the bottom unit.
- Unscrew the vent hood plate from the bottom oven. Remove and discard the hood plate and spacer tubes. Replace the vent hood screws and completely screw in to secure the wrapper to the spacer tube.
- Position the shroud rear (**3**) (refer to figure 1) on top of the bottom unit so that it is positioned correctly over the oven back. Position the flue duct (**6**) on the bottom unit so that it is positioned centrally in shroud rear flue cut-out and is flush with the oven back. Check that the oven vent is covered and mark the six hole positions (three down each side of the flue duct) on the oven wrapper.
- Drill six  $\varnothing 3.5\text{mm}$  ( $\frac{1}{8}$ " ) holes in the oven wrapper where marked.
- Apply a small amount of silicone sealant to the flue duct flanges and screw to the wrapper with six  $\frac{1}{2}$ " x 8A pozi screws (**7**) along the top, and two at the rear.

### B. Top Unit - G32/M/MS

- Tip the oven onto its back and remove the feet/legs screwed into the base.
- Assemble the four sides of the shroud (shroud front (**1**), shroud sides x2 (**2**), and shroud rear (**3**)) with the  $\frac{3}{16}$ " screws (**8**) as illustrated. Do not fully tighten the screws until the ovens are stacked.
- Screw the shroud assembly to the base of the top oven using the  $\frac{3}{8}$ " hex head screws and washers (**9**) so that all faces of the shroud are flush with the sides of the oven base. Be sure to have the large flange of the shroud rear at the back of the oven.

### C. Stacking the Ovens

- Remove three screws along the top rear of the bottom oven.
- With two or three persons, lift the top oven onto the bottom oven and position so that the down folds on the shroud sides and rear all butt hard up around the sides and rear of the oven wrapper.
- Secure the top unit into position by replacing the three screws along the rear of the oven.

- Drill three  $\varnothing 3.5\text{mm}$  ( $1/8''$ ) holes along each side of the bottom oven and secure with six  $1/2''$  x 8A pozi screws (7).
- Position the chimney (4) on the rear of the units. Secure to the flue duct (6) and bottom unit with four  $1/2''$  x 8A pozi screws (7). (The holes in the bottom unit may need to be drilled,  $\varnothing 3.5\text{mm}$  ( $1/8''$ )).
- Secure the top of the chimney to the top unit with the chimney support (5) and two  $1/2''$  x 8A pozi screws (7). (These holes may need to be drilled,  $\varnothing 3.5\text{mm}$  ( $1/8''$ )).
- Ensure that all screws on the stacking kit are tightened.

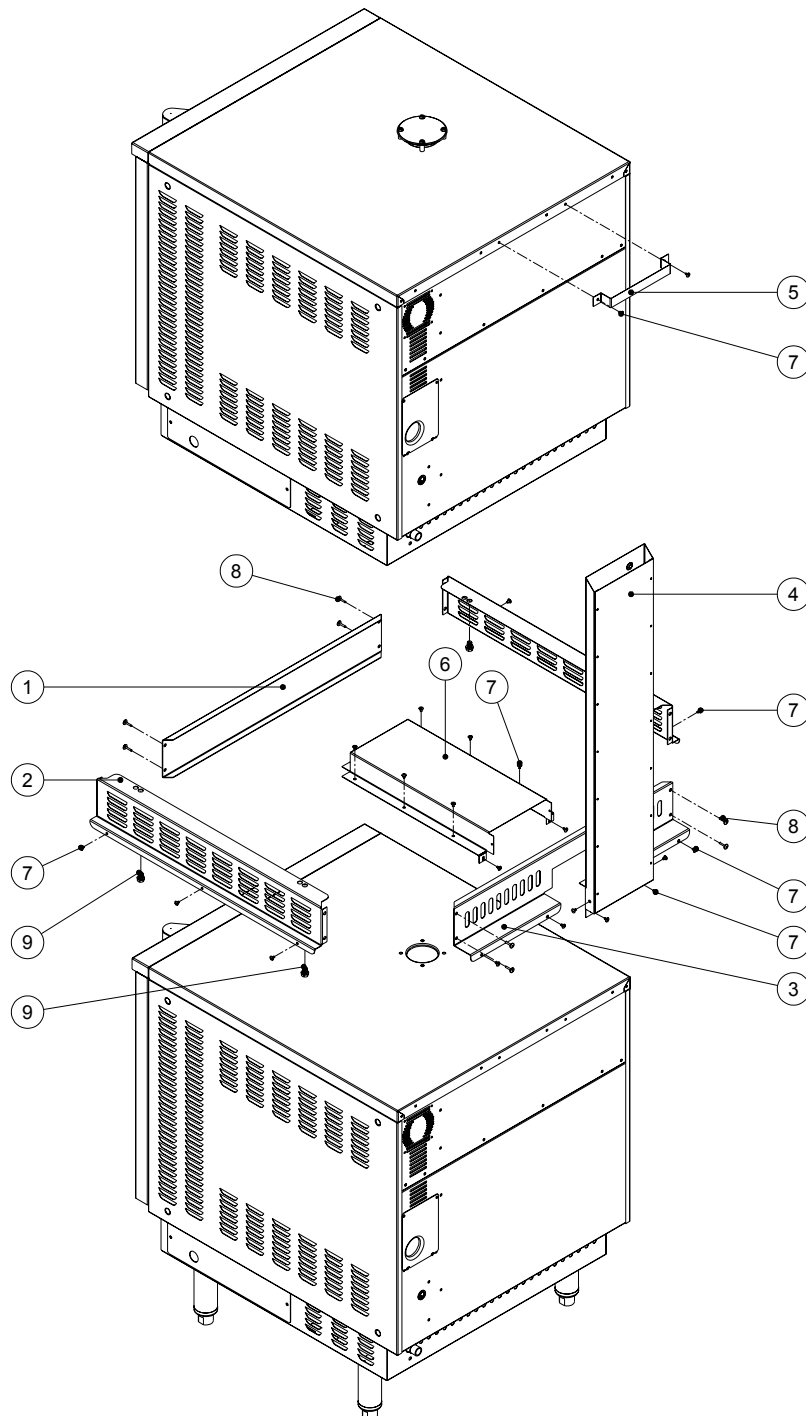

Figure B.1

## APPENDIX D. MOTOR REPLACEMENT KIT

**014672K Motor Kit**  
208—240V Models

**015821K Motor Kit**  
110—120V Models

**⚠ SERVICE WORK ONLY TO BE CARRIED OUT BY QUALIFIED PERSONS**

### Contents:

- 1 Motor
- 3 Screw 5/32"
- 3 M4 Spring Washer
- 1 Insulation Disk

**CAUTION: ENSURE UNIT IS ISOLATED FROM GAS / ELECTRICAL SUPPLIES BEFORE SERVICING**

### Instructions:

- 1) Open oven door and remove fan baffle, undo nut securing fan to shaft (Note: left hand thread, turn clockwise to loosen) and remove fan.

**NOTE:** This motor may have a different motor frame mounting bracket than the original. Use supplied short screws and washers in place of existing long screws in this case.

- 2) Remove side service panel (four screws).
- 3) Remove the wires from the motor noting their positions.
- 4) Remove motor (three screws).
- 5) Check new motor is same voltage range as previous type, (i.e. 110-120V or 208 - 240V)
- 6) Fit new motor with the three screws and washers provided, ensure insulation disk is fitted between the motor and motor mounting plate.
- 7) Reconnect wires as per original.
- 8) Refit fan and fan baffle from inside of oven.

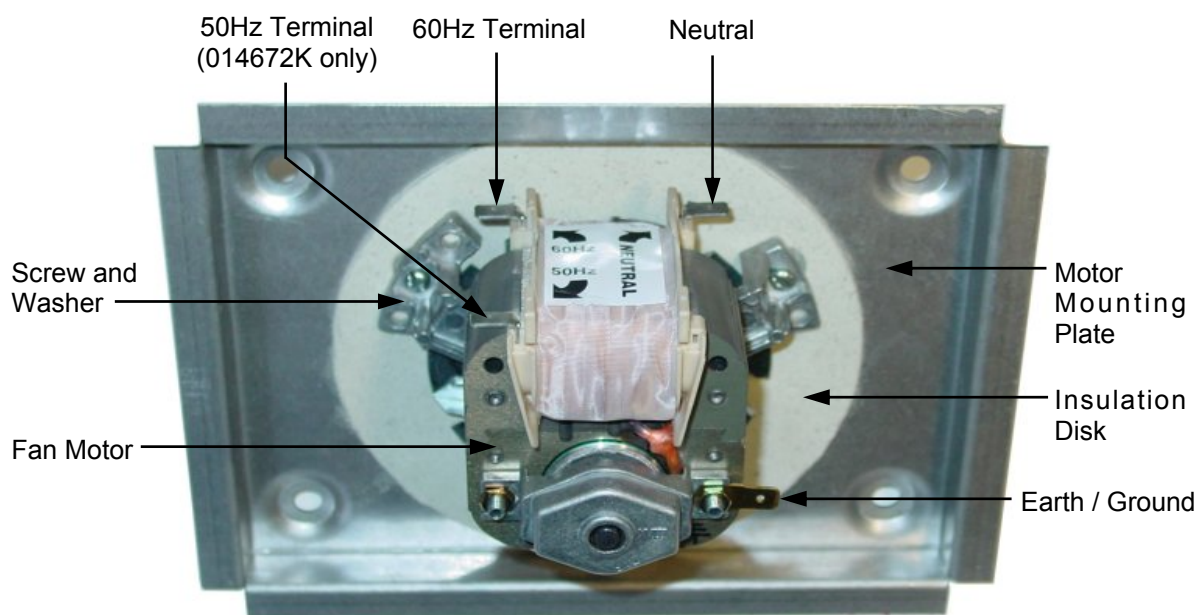

Figure A.