

INSTRUCTIONAL MANUAL



GAS FIRED BROILERS

E36W36
E43W36
E136W36
EV136W36

E236W36
E243W36
EC36
EC45

EC36W36
WC43W36
E136C36
E136C45

EV136C36
EV136C45
W136XC36
W136XC45

with optional searing plate (-SHB)

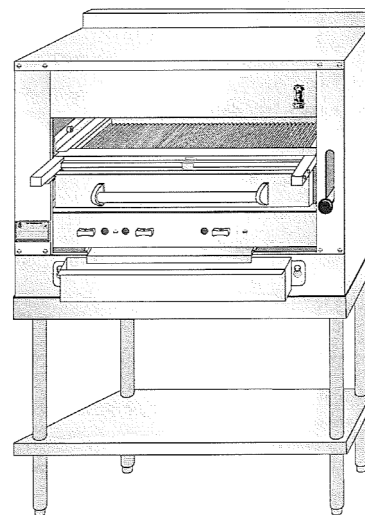

NOTICE:

This manual is prepared for the use of **Service Technicians** and should not be used by those not properly qualified. This manual is not intended to be all encompassing. You should read, in its entirety, the repair procedure you wish to perform to determine if you have the necessary tools, instruments, and skills required to perform the procedure.

RETAIN THIS MANUAL FOR FUTURE REFERENCE.

DESTINATION COUNTRIES: AUSTRALIA, NEW ZEALAND

THE MONTAGUE COMPANY

1830 Stearman Avenue • P.O. BOX 4954 • HAYWARD, CA 94540-4954 • TEL: 510/785-8822 • FAX: 510/785-3342

www.montaguecompany.com

IMPORTANT FOR YOUR SAFETY

THE INSTALLATION INSTRUCTIONS CONTAINED HEREIN ARE FOR THE USE OF QUALIFIED INSTALLATION AND SERVICE PERSONNEL ONLY. INSTALLATION OR SERVICE BY OTHER THAN QUALIFIED PERSONNEL MAY RESULT IN DAMAGE TO THE UNIT AND/OR INJURY TO THE OPERATOR.

IF YOU SMELL GAS

1. TURN OFF THE APPLIANCE AT THE GAS INLET COCK AND OPEN ALL DOORS AND WINDOWS.
2. DO NOT OPERATE ANY ELECTRICAL SWITCHES AND EXTINGUISH ALL NAKED FLAMES.
3. CONTACT THE LOCAL GAS AUTHORITY IMMEDIATELY.

THE FOLLOWING INSTRUCTIONS SHOULD BE READ CAREFULLY AS THE MANUFACTURER CANNOT BE HELD RESPONSIBLE FOR ANY DAMAGE TO PROPERTY, PERSONS OR ANIMALS CAUSED BY INCORRECT INSTALLATION OR OPERATION OF THE APPLIANCE.

POST IN A PROMINENT LOCATION THE INSTRUCTIONS TO BE FOLLOWED IN THE EVENT THE SMELL OF GAS IS DETECTED. THIS INFORMATION CAN BE OBTAINED FROM THE LOCAL GAS SUPPLIER.

IN THE EVENT OF POWER FAILURE, DO NOT ATTEMPT TO OPERATE THIS DEVICE.

IMPORTANT

IN THE EVENT A GAS ODOR IS DETECTED, SHUT DOWN UNITS AT MAIN SHUTOFF VALVE AND CONTACT THE LOCAL GAS COMPANY OR SUPPLIER FOR SERVICE.

FOR YOUR SAFETY

DO NOT SPRAY AEROSOLS, STORE OR USE GASOLINE OR OTHER FLAMMABLE VAPORS OR LIQUIDS IN THE VICINITY OF THIS APPLIANCE WHILE IN OPERATION.

WARNING!

Improper installation, adjustment, alteration, service, or maintenance can cause property damage, injury, or death. Read the INSTALLATION AND OPERATING INSTRUCTIONS thoroughly before installing, servicing, or operating this equipment.

SAVE THESE INSTRUCTIONS FOR FUTURE USE.

TABLE OF CONTENTS

IMPORTANT FOR YOUR SAFETY	2	C36 & C45 EXPLODED VIEW	20
INTRODUCTION	4	C36 & C45 PARTS LIST	21
GENERAL	4	36W36 & 43W36 EXPLODED VIEW	22
MODELS	4	36W36 & 43W36 PARTS LIST	23
DATA PLATE LOCATION	4	Montague E136 Series Heavy Duty Range Parts List	24
SERIAL NUMBER LOCATION	4	PARTS REMOVAL AND REPLACEMENT PROCEDURES	27
RECEIVING AND INSPECTING THE EQUIPMENT	4	COVERS AND PANELS	27
SPECIFICATIONS	5	Venturi Cover	27
INSTALLATION	6	Control Panel Cover	27
STATUTORY REGULATIONS	6	DRIP DEFLECTOR	28
CLEARANCES	6	PILOT ASSEMBLY AND INJECTOR	29
VENTILATING HOOD	6	MAIN BURNER	30
VENTILATION AIR	6	Burner Assembly, Orifice, and Venturi	31
ASSEMBLY	6	Burner Valve Removal/Replacement	31
Legs	6	CARRIAGE POSITION HANDLE	32
ELECTRICAL CONNECTION	7	Black Ball Knob	32
Ceramic Radiants	8	Chrome Sleeve	32
LOCATION	8	Threaded Stud	32
SITING	8	Gear and Tube Assembly	32
BATTERY ARRANGEMENT	8	Compression Spring	33
Setting in Place	8	Gear with Bracket	33
Floor Mounted Ranges	9	SERVICE AND ADJUSTMENT PROCEDURES	33
GAS SUPPLY	9	GAS PRESSURE REGULATOR ADJUSTMENT PROCEDURE	33
GAS CONNECTION	9	PILOT BURNER CLEANING AND ADJUSTMENT PROCEDURE	34
GAS PRESSURE REGULATOR	10	GAS TAPS	34
Adjustment Procedure	11	CLEANING BURNER HEADS	34
PILOT INITIAL ADJUSTMENT	12	CLEANING BURNER VENTURI	34
BURNER ADJUSTMENT	12	CARRIAGE POSITION HANDLE	34
OPERATION	15	ADJUSTMENT PROCEDURE	34
GENERAL	15	Handle Tension Adjustment	34
OPERATING CONTROLS	16	CARRIAGE TENSION SPRING ADJUSTMENT PROCEDURE	35
Gas Control	15	MISCELLANEOUS	35
Lighting/Relighting Pilot and Main Burner	15	SAFETY AND PILOT BURNER INSPECTION	36
Shutdown	16	SAFETY PILOT VALVE	36
Grid Height Adjustment	16	OVEN PILOT BURNER	36
GENERAL MAINTENANCE	18	OPERATIONAL DIFFICULTIES & PROBABLE CAUSES	37
GENERAL CLEANING	18	TROUBLESHOOTING CHART	38
Daily	18	EC36 & E45 EXPLODED VIEW	39
PAINTED SURFACES	18	EC36 & E45 PARTS LIST	40
Exterior	18	E36W36 & E43W36 EXPLODED VIEW	42
Interior	18	E36W36 & E43W36 PARTS LIST	43
STAINLESS STEEL SURFACES	18	Montague E136 Series Heavy Duty Range Parts List	46
VENTILATION	19		
SERVICING	19		
SAFETY	19		

INTRODUCTION

GENERAL

The gas broilers covered in this manual are manufactured for use with the type of gas indicated on the nameplate. Some models include a cabinet, conventional oven or convection oven. Ovens are covered in separate manuals. This manual only covers the broiler.

Montague gas broilers are produced with the best possible material and workmanship. Proper installation is essential for safe, efficient, trouble-free operation.

MODELS

MODEL	CONSISTS OF
E36W36 E43W36	Cabinet Base Broiler with Warming Oven
EV136W36 E136W36	Broiler with Conv. or Std. Oven + Warming Oven (opt. 'W45)
EV136C36 E136C36	Broiler with Convection or Standard Oven (opt. 'C45)
E136XC36	Broiler w/ Low Oven (opt. 'C45)
E236W36	Double Broiler (opt. E243W36)
EC36	Broiler w/ Stand (opt. EC45)
EC36W36	Double Broiler + Warming Oven
EC45W36	Double Broiler + Warming Oven

Note: A suffix of "SHB" designates searing plate option.

DATA PLATE LOCATION

The Data Plate is located on the front of the unit, or inside the oven burner.

SERIAL NUMBER LOCATION

Always have the serial number of your unit available when calling for parts or service. The serial number is on the nameplate that also includes the model number. A typical identification plate is shown in Figure 1.

MODEL:			
SERIAL NO.:			
HEAT INPUT:			kW
CATEGORY:			
SUPPLY PRESSURE:			mbar
GAS:	SET PRESS:	mbar	
ELECTRICAL			
V	Hz	Ph	W
COUNTRY:			
P.I.N:			
		GAS CATERING EQUIPMENT SALAMANDER- TYPE A	
THE MONTAGUE COMPANY HAYWARD, CALIFORNIA USA			

Figure 1. Typical Nameplate

RECEIVING AND INSPECTING THE EQUIPMENT

Care should be taken during unloading so the equipment is not damaged while being moved into the building.

1. Visually inspect the exterior of the package and skid or container. Any damage should be noted and reported to the delivering carrier immediately.
2. If damaged, open and inspect the contents with the carrier.
3. In the event that the exterior is not damaged, yet upon opening, there is concealed damage to the equipment, notify the carrier. Notification should be made verbally as well as in written form.
4. Request an inspection by the shipping company of the damaged equipment. This should be done within 10 days from receipt of the equipment.
5. Freight carriers can supply the necessary damage forms upon request.
6. Retain all shipping materials until an inspection has been made or waived.

SPECIFICATIONS

Table A: Heat Input

MODEL	No. Burners (broiler/oven)	Natural Gas MJ/h	Propane Gas MJ/h	TOTAL MJ/h
E36W36	2 / 0	44.3 ea.	44.3 ea.	88.6
E43W36	3 / 0	44.3 ea.	44.3 ea.	132.9
E136W36	2 / 1	44.3 / 42.2 ea.	44.3 / 42.2 ea.	130.8
EV136W36	2 / 1	44.3 / 42.2 ea.	44.3 / 42.2 ea.	130.8
E236W36	4 / 0	44.3 ea.	44.3 ea.	177.2
E243W36	6 / 0	44.3 ea.	44.3 ea.	265.8
EC36	2 / 0	44.3 ea.	44.3 ea.	88.6
EC45	3 / 0	44.3 ea.	44.3 ea.	132.9

Table B: Setting Pressure/Injector Size

Manifold Pressure

Natural: 1.0kPa
Propane: 2.75 kPa

Orifices

Fixed for specified gas type
Natural: Broiler: 3.05mm Oven: 2.95mm
Propane: Broiler: 1.93mm Oven: 1.85mm

Gas Inlet Size:
3/4" NPT at lower left rear
(all models)

NOTE: The pressure must be measured at the pressure test nipple located at the manifold pipe with the burner lit.

TABLE C: Aeration Shutter/Pilot Flame Settings

MODEL	Natural Gas Broiler/Oven mm	Propane Broiler/Oven mm	PILOT FLAME LENGTH mm
E36W36	25 / —	32 / —	12.5
E43W36	25 / —	32 / —	12.5
E136W36	25 / 19	32 / 22	12.5
EV136W36	25 / 19	32 / 22	12.5
E236W36	25 / —	32 / —	12.5
E243W36	25 / —	32 / —	12.5
EC36	25 / —	32 / —	12.5
EC45	25 / —	32 / —	12.5

INSTALLATION

THIS APPLIANCE, WHEN INSTALLED, MUST BE ELECTRICALLY GROUNDED IN ACCORDANCE WITH LOCAL CODES. THIS APPLIANCE MUST BE INSTALLED WITH THE REQUIREMENTS OF AS5601 / AG601, LOCAL AUTHORITY, GAS, ELECTRICITY AND ANY OTHER RELEVANT STATUTORY REGULATIONS.

CAUTION: Provision must be made to assure adequate air supply to unit for proper burner operation.

STATUTORY REGULATIONS

The installation of this appliance must be carried out by a competent person in accordance with the relevant regulations, standards, codes of practice, and the related publications of the country of destination.

CLEARANCES

The following are minimum clearances from combustible and noncombustible materials.

Location	Combustible Construction	Noncombustible Construction
Back Wall	152 mm	0 mm
Left Side	152 mm	0 mm
Right Side	152 mm	0 mm

1000mm clearance above to combustibles.

With 152mm legs: Suitable for installation on combustible floors.

Without legs: For use with special insulated base on noncombustible floors only.

The EV 136 must have an air space behind it.

VENTILATING HOOD

The broiler(s) must be installed under a properly designed ventilating hood. The hood should extend at least 152mm beyond all sides of the unit. The hood should be connected to an adequate mechanical exhaust system.

VENTILATION AIR

The following notes are intended to give general guidance. For detailed recommendations, refer to the applicable code(s) in the country of destination.

NOTE 1: The room containing the appliance is required to have a permanent air vent. The minimum effective area of the vent is related to the maximum rated heat input of the appliance and shall be 4.5 cm² per kW in excess of 7kW.

NOTE 2: Air vents should be of such a size to compensate for the effects of any extract fan in the premises.

It is also necessary that sufficient room air ingress be allowed to compensate for the amount of air removed by the ventilating system. Otherwise, a subnormal atmospheric pressure will occur which may interfere with burner performance or may extinguish the pilot flame. In case of unsatisfactory broiler performance, check with the exhaust fan in the "OFF" position.

This appliance is to be installed with sufficient ventilation to prevent the occurrence of unacceptable concentrations of substances harmful to health in the room in which it is installed.

ASSEMBLY

Uncrate broiler as near to final location as possible. For easier and lighter handling of broiler, remove grids, grid frame, drip tray and grease container. Remove all packing materials and accessories from broiler interior.

Legs

Some broilers are mounted on legs.

1. Screws the legs into the modular stand.
2. Tightly screw the complete leg assembly into the mounting holes in the bottom of the broiler at each corner. If the unit is intended for curb installation, no legs are provided. The curb must be noncombustible material.

THE GAS CONNECTION IS LOCATED 813mm ABOVE THE FINISHED FLOOR AND 127mm FROM THE LEFT SIDE ON THE REAR OF THE UNIT

Electrical Connection

A terminal block is provided for 208-240 VAC equipment. The wiring diagram is located on the back of the range. To connect supply wires, remove cover from connection box at right rear of range. Route supply wires and ground wire through hole with strain relief fitting at top of connection box. Attach supply wires to proper terminal of terminal block. Attach ground wire to ground loug inside connection box. See wiring diagram for proper connection.

THIS APPLIANCE, WHEN INSTALLED, MUST BE ELECTRICALLY GROUNDED IN ACCORDANCE WITH LOCAL CODES. THIS APPLIANCE MUST BE INSTALLED WITH THE REQUIREMENTS OF AS5601 / AG601, LOCAL AUTHORITY, GAS, ELECTRICITY, AND ANY OTHER RELEVANT STATUTORY REGULATIONS.

THE ELECTRICAL CONNECTION IS LOCATED 254mm ABOVE THE FINISHED FLOOR AND 305mm FROM THE RIGHT SIDE ON THE REAR OF THE UNIT.

The installation of electrical wiring from the electric meter, main control box, or service outlet to the electric appliance must be performed by a licensed electrician. Qualified installation personnel must be experienced with such work, be familiar with all precautions required and have complied with all requirements of state or local authorities having jurisdiction.

OVERALL DIMENSIONS (in millimetres):

Model	Height	Width	Depth
E36W36	1816	914	933
E43W36	1816	1143	933
E(V)136W36	1816	914	933
E(V)136C36	1451	914	933
E(V)136C45	1451	1143	933
E136XC36(SHB)	1426	914	870
E136XC45(SHB)	1426	1143	870
E236W36	1603	914	870
E243W36	1603	1143	870
EC36(SHB)	1324	914	870
EC45(SHB)	1324	1143	870
EC36W36	1968	914	864
EC43W36	1968	1143	864

Ceramic Radiants

Ceramic radiants, Figure 2, are located on each side of the burners. Ceramic end pieces are installed at both ends of each burner assembly. Five (5) ceramic radiants are installed on each side of the burner with the pointed side facing down and the side holes facing up, Figure 3.

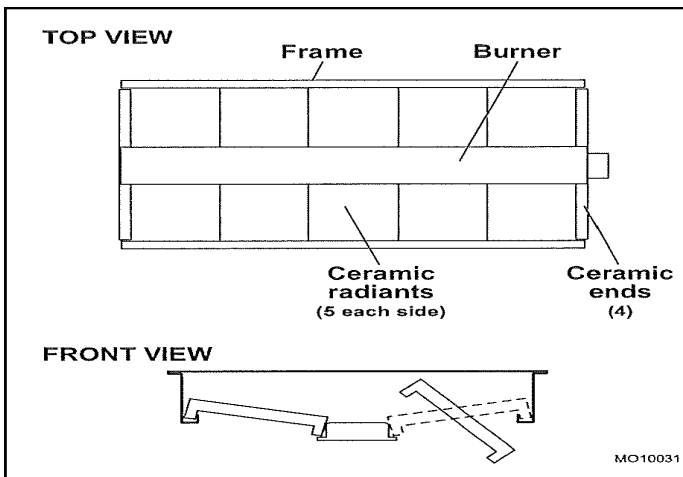

Figure 2. Ceramic Radiants Positioning

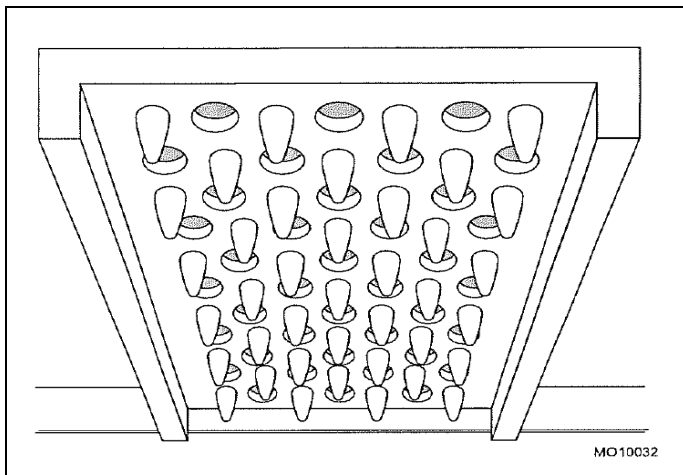

Figure 3. Ceramic Radiants

1. Insert ceramic end pieces at front and rear of the burner frame. Four (4) are required for each burner.

2. Tilt ceramic radiants sideways to clear burner and frame assembly, then lower radiant into position with one flange resting on burner ledge and one flange resting on frame edge.
3. Install the remaining ceramic radiants so that five (5) ceramic radiants are located on each side of the burner.

LOCATION

Adequate clearance for service and proper operation must be provided at the front, top, sides, and back. The combustion air openings are provided in the front of the unit and must not be obstructed.

SITING

The floor on which the range is to be sited must be capable of adequately supporting the weight of the appliance and any ancillary equipment. Once in position, check that the unit is level, both front to back and side to side. Adjust if necessary, using the adjusting foot on each leg.

BATTERY ARRANGEMENT

Carefully remove range from crate. Burner tie wires and other packing materials must be removed from the unit. On stainless steel units, the protective material covering the stainless steel must be removed immediately after unit is installed.

Setting in Place

Model Nos. E36W36, E43W36, E136W36 and EV136W36.

Floor Mounted Ranges

1. Place the first unit in the exact position it will occupy in the battery.
2. Using a carpenter's level, level the unit front-to-rear and side-to-side. **AN UNLEVELED UNIT WILL ADVERSELY AFFECT PERFORMANCE.** Adjust as follows:

FLOOR INSTALLATION ON LEGS: Level by turning foot on leg.

CURB INSTALLATION: Place shim under the low side. This operation is important since variations in floors and curbs are common. Unless units are level, aligning the gas supply manifold will be difficult and the units will not fit together tightly.

3. Remove the valve panel from the broiler.
4. Move the next unit into position.
5. Engage union nut on manifold with male fitting on next unit and draw up union nut hand tight. Be sure appliances meet together both front and rear. If manifolds do not align, then units are not level. In extreme cases, it may be necessary to loosen manifold bolts and adjust.
6. Continue leveling and connecting gas supply manifolds together until all appliances in battery are connected.
7. Tighten manifold gas union. Use backup wrench to prevent manifold from rotating.

FAILURE TO DO THIS MAY RESULT IN DAMAGE TO THE PILOTS AND GAS VALVES.

GAS SUPPLY

The local gas region should be consulted at the installation planning stage in order to establish the availability of an adequate supply of gas and to ensure that the meter is adequate for the required flow rate. The pipe work from the meter to the appliances must be of appropriate size. Where a number of appliances are installed in a battery, no more than five should be served by any one supply pipe.

All fixed (non-mobile) appliances **MUST** be fitted with a manual gas cook upstream of the appliance to provide a means of isolation for servicing and cleaning. A union or similar means of disconnection must be provided between the gas cook and the appliance.

A manually operable valve must be fitted to the gas supply to the kitchen to enable it to be isolated in an emergency. Wherever practical, this shall be located either outside the kitchen or near an exit in a readily accessible position.

Where it is not practical to do this, an automatic isolation valve system shall be fitted which can be operated from a readily accessible position near the exit.

At locations where the manual isolation valve is fitted or the automatic system can be reset, a notice **MUST** be fitted, stating:

“ALL DOWNSTREAM BURNER AND PILOT VALVES MUST BE TURNED OFF PRIOR TO ATTEMPTING TO RESTORE THE SUPPLY. AFTER EXTENDED SHUT OFF, PURGE BEFORE RESTORING GAS.”

GAS CONNECTION

Before connecting the broiler(s) to the gas supply line, be sure that all new piping has been cleaned and purged to prevent any foreign matter from being carried into the controls by the gas. In some cases, filters or drops are recommended. A separate gas shutoff valve must be installed upstream from the gas pressure regulator adjacent to the broiler and located in an accessible area.

It is important that adequately sized piping be run directly to the point of connection at the broiler with as few elbows and tees as possible. Consult your local gas company for proper piping size and gas pressure. Each broiler has a 3/4" NPT manifold input located at the lower left rear of the broiler, Figure 4. On dual broilers, each broiler must have a separate regulator.

NOTE: Pipe joint compound or thread sealant that is used should be resistant to action of liquefied petroleum gases.

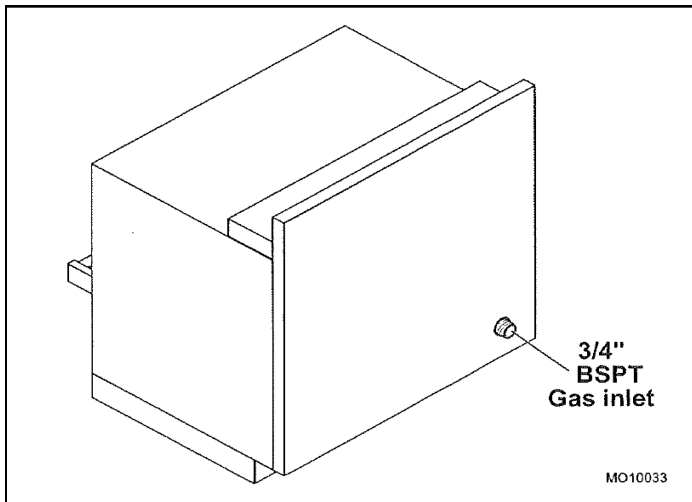

Figure 4. Gas Inlet

Install the gas pressure regulator with gas flowing as indicated by the arrow on the regulator. The arrow must be pointing in toward the unit. Use pipe compound or thread sealant and carefully thread regulator to pipe so that there is no cross threading, etc., which could cause leakage.

1. Apply wrench only to the flat areas around the pipe tapping at the end being threaded to the pipe to avoid possible damage to the regulator body which could result in leakage.

2. Connect the gas supply line from the service gas shutoff valve to the inlet side of the gas pressure regulator using 3/4" pipe. Avoid kinks or sharp bends that could restrict gas flow.

NOTE: If flexible or semi-flexible connectors are used, an AGA listed flexible connector with an I.D. equal to 3/4" pipe must be used.

WARNING!
DO NOT USE A DOMESTIC TYPE FLEXIBLE GAS CONNECTOR.

3. Turn gas shutoff valve on and carefully check for gas leaks immediately. Do this before attempting to operate the broiler.

WARNING!

Test all pipe joints for leaks before operating broiler. This includes all gas connections that may have loosened during shipment. Use a rich soap solution (or other accepted leak tester) around all pipe connections and all other joints. Do not use an open flame. Absolutely no leakage should occur, otherwise there is a danger of fire or explosion depending upon conditions. Do not use unit leakage is detected.

After piping has been checked for leaks, all piping receiving gas should be fully purged to remove air.

GAS PRESSURE REGULATOR

WARNING!

THE BROILER(S) IS/ARE DESIGNED FOR USE WITH A GAS PRESSURE REGULATOR. THE REGULATOR(S) SUPPLIED WITH THIS UNIT MUST BE USED.

FOR NATURAL GAS: This gas pressure regulator is factory adjusted for 1.0 kPa manifold pressure. The rated inlet pressure to the regulator is 3.45 kPa.

FOR PROPANE GAS: This gas pressure regulator is factory adjusted for 2.75 kPa manifold pressure. The rated inlet pressure to the regulator is 3.45 kPa.

The broiler is equipped with fixed orifices for use with a manifold pressure of 1.0 kPa for G20 gas and 2.75 mbar for propane gas.

Position the gas pressure regulator outside the broiler as near to the unit as possible.

CAUTION: The gas pressure regulator must be located out of the heat zone to prevent damage to the regulator.

The whole of the gas installation, including the meter, should be inspected, purged, and tested for soundness in accordance with the codes of the country of destination.

Adjustment Procedure

WARNING!

DO NOT ALLOW UNTRAINED PERSONNEL TO MAINTAIN OR SERVICE THE GAS PRESSURE REGULATOR.

1. Before adjusting the regulator, check the incoming gas line pressure into the regulator. Incoming pressure must be 20 kPa for natural gas or 3.5 kPa for propane gas.
2. If incoming pressure is not correct, have the gas source checked and adjusted.
3. Make sure that the regulator is mounted in the horizontal position with the arrow pointing in the direction of the gas flow. SEE PAGE 15, LIGHTING/RELIGHTING PILOT AND BURNER.
4. Remove the main burner control valve knobs, Figure 5.

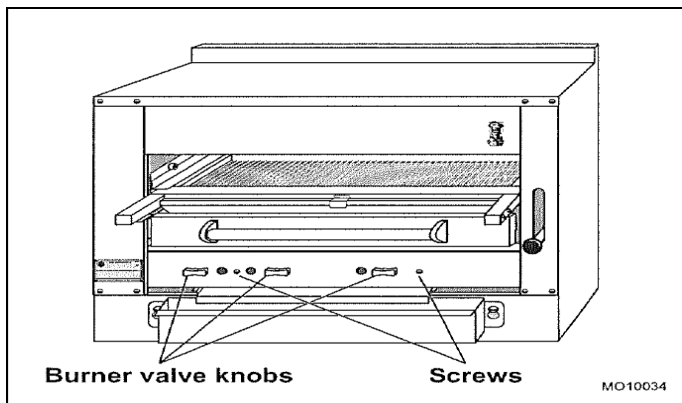

Figure 5. Control Valve Knobs

5. Remove the control valve panel by removing two screws.

6. Connect a manometer to the pressure tap provided on the broiler unit gas piping manifold, Figure 6. Turn all gas taps to the full on "O" position.

7. Check the manometer reading. The reading must be 1.0 kPa for natural gas or 2.75 kPa for propane gas, per Table B on PAGE 5.

8. If incoming line pressure is not correct, adjust the regulator. Remove the seal cap on the top of the regulator.

9. Insert a blade-type screwdriver into the top hole of the regulator.

10. Turn the adjustment screw clockwise to increase the pressure, or counter clockwise to decrease the pressure.

While watching the manometer, turn the adjustment screw to set proper regulator outlet pressure to the manifold.

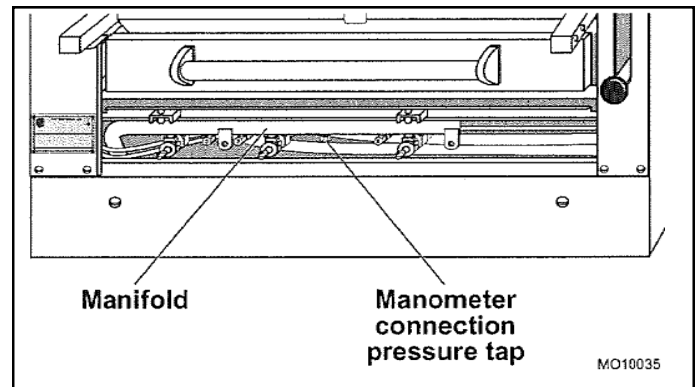

Figure 6. Gas Pressure Tap

PILOT INITIAL ADJUSTMENT

Each burner has a separate pilot burner. The pilot flame is adjusted through access holes in the valve control panel, Figure 7. Pilot access is through the broiler opening.

1. Turn the main gas shut off valve to the ON position.
2. Light each pilot.
3. Ensure that each pilot burner has a steady blue flame, Figure 7, per Table C on PAGE 5. The pilot flame should envelop the tip of the thermocouple. The pilot flame can be viewed up through the opening of the broiler compartment.

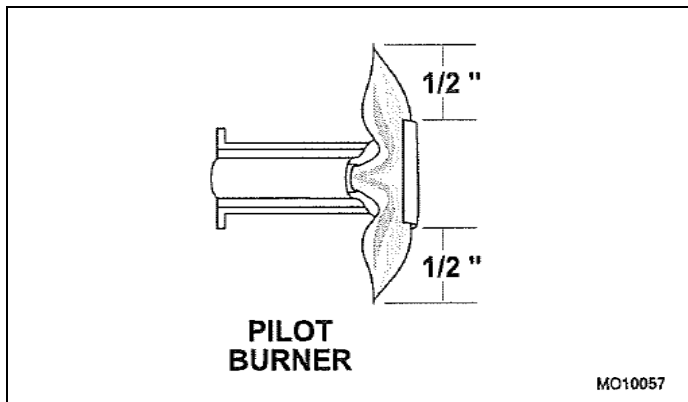

Figure 7. Pilot Burner

Replace the control valve panel and the main control valve handles.

BURNER ADJUSTMENT

The efficiency of the broiler depends on a delicate balance between the supply of air and the volume of gas at each main burner resulting in complete combustion. Whenever this balance is disturbed, poor operating characteristics occur. An air shutter, Figure 8, on the front of each main burner controls the air supply.

NOTE: Pilots should be lit, SEE PAGE 12, before adjusting the main burners.

1. Lift off the Venturi cover to access the air shutter for each main burner.
2. Turn on the main burner control valve for the main burner to be adjusted by rotating the main burner control valve fully counter-clockwise to the "O" position.
3. Increase the air shutter openings until the flame on the burner begins to "lift". Then close the shutter until flame no longer floats, and lock in place. A yellow streaming flame indicates insufficient air. Correct this condition by increasing air shutter opening. The correct setting is shown on Table C on PAGE 5.

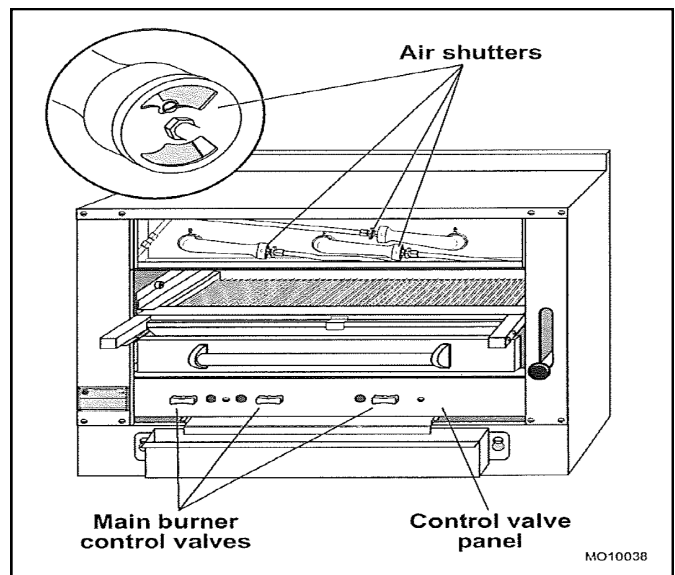
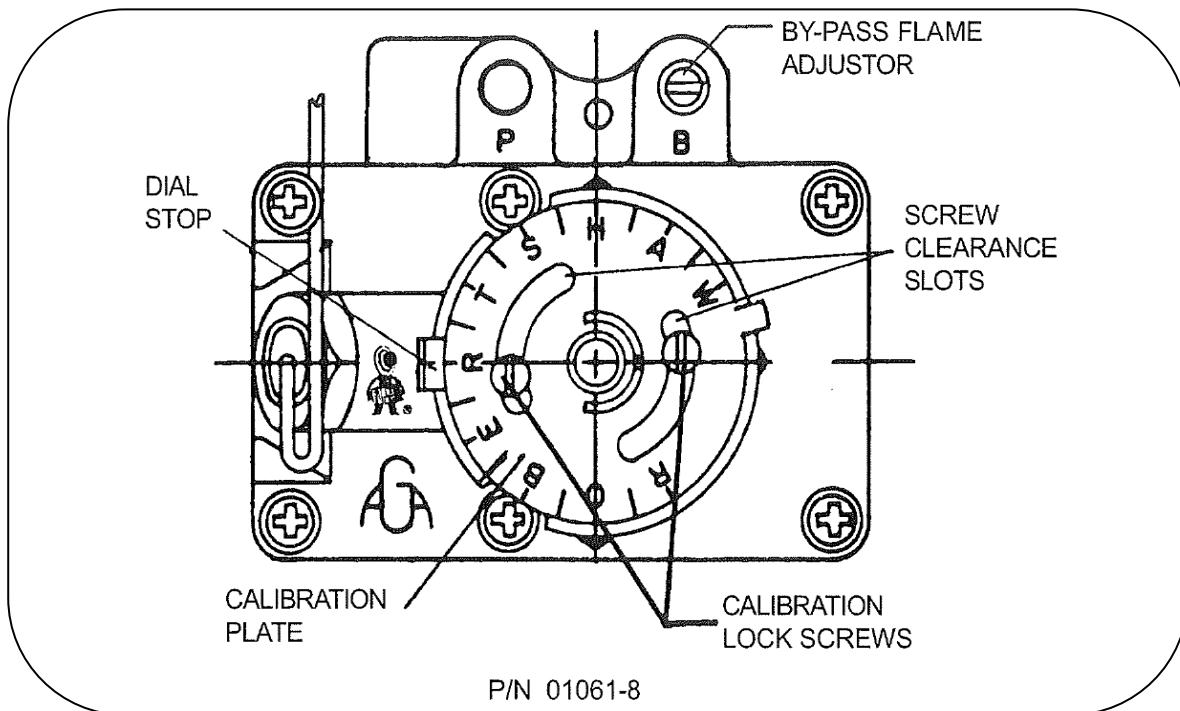

Figure 8. Main Burner Air Shutter

4. After all main burners are properly adjusted, reinstall the Venturi cover.
5. Turn all main burner control valves fully clockwise to the "O" position to turn the main burner off.

OVEN MINIMUM FLAME SETTING

This is the flame that must be maintained on the burner when the oven has come up to the temperature set on the dial. Enough gas must be bypassed by the control to keep the entire burner lit. The thermostat regulates the flame from high to low in accordance with the oven temperature and will automatically turn down to this minimum flame when the temperature set on the dial is attained in the oven.



1. Light the oven, set thermostat to 100°C and allow 5 minutes for the oven temperature to stabilize.
2. After oven temperature rises and remains constant, turn dial back to low. This closes the main valve and permits only the bypass gas to the burner.
3. Remove dial.
4. With a screwdriver, turn the bypass flame adjustor screw counterclockwise to increase the bypass flame or clockwise to decrease it until the flame over the entire burner is approximately 4mm high. Replace dial.

THERMOSTAT CALIBRATION CHECK

The calibration of this thermostat should not be changed until considerable experience with cooking results has definitely proved that the thermostat is not maintaining the proper temperature. The recalibration should not be made until the bypass (minimum burner) flame has been properly adjusted.

If re-calibration becomes necessary, the following procedure should be followed:

1. Place the thermocouple of test instrument or thermometer in the middle of the oven.
2. Light the main burner.
3. Turn dial to between the "180" and the "200" position (190).
4. Allow the oven to heat until the flames cut down to bypass. After sufficient time, check temperature. If the temperature does not read within 10 degrees of the dial setting, recalibrate as follows:
 - A. Pull dial straight off without turning.
 - B. Hold calibration plate and loosen the two calibration lock screws until the plate can be moved independently of the control.
 - C. Turn calibration plate so that the instrument or thermometer reading is in line with the indicator mark. Hold plate and tighten screws firmly. Turn the calibration plate counter clockwise if the test reading is higher than the dial setting. Replace dial.

NOTE: If the above adjustment is prevented by the two loosened calibration lock screws being in contact with the ends of the screw clearance slots in the calibration plate, remove the screws and after turning the calibration plate to the proper location, reassemble screws in the other tapped holes designed for them.

OVEN

- A. Light pilot in accordance with the Lighting Instructions.
- B. Check that the length of the pilot flame is correct per table C.

All pilot flames should envelop the tip of the thermocouple. The pilot flame can be viewed through the opening in the front of the burner compartment panel.

Replace the burner access panel.

Hand the Instructions & Operation Manual to the user or purchaser for retention and instruct them in the efficient and safe operation of the appliance.

Tell the user of the location of the gas isolation cock for use in an emergency.

Leave this manual with the user or purchaser.

OPERATION

GENERAL

This appliance has been classified as commercial cooking equipment and must be operated by qualified and/or professional operating personnel.

WARNING!

The broiler and its parts are hot. Use care when operating or servicing the unit.

CAUTION:

Do not obstruct the flow of combustion and ventilation air to the broiler. Keep appliance area free and clear of combustibles.

OPERATING CONTROLS

WARNING!

IN THE EVENT GAS ODOR IS DETECTED, SHUT DOWN UNITS AT MAIN GAS SHUTOFF VALVE AND CONTACT THE LOCAL GAS COMPANY OR GAS SUPPLIER FOR SERVICE.

The following controls are used for operation of the broiler, Figure 9.

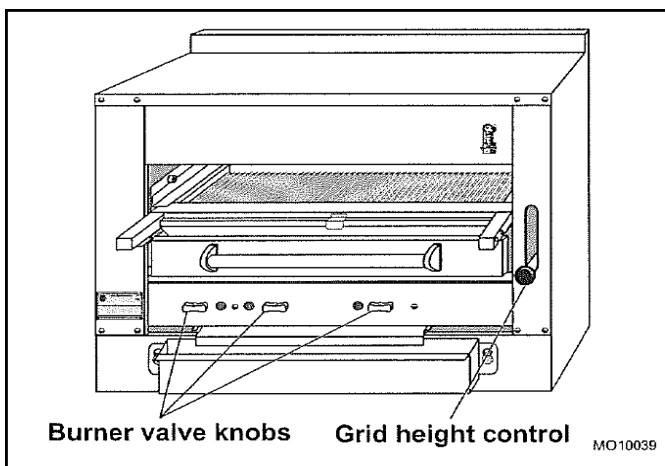

Figure 9. Operating Controls

BURNER CONTROL: Used to turn the main burner and pilot gas on or off. One control for each burner.

GRID HEIGHT: The grid is set to the desired cooking height by depressing the ball and adjusting the lever up or down.

Gas Control

Lighting/Relighting Pilot and Main Burner

1. Turn burner valve handle to off position and wait five (5) minutes.
2. Push in the tap and turn it counter-clockwise to the ignition position.
3. Holding the tap fully in, light the pilot with a match or taper.
4. When the pilot is lit, continue to hold the tap in for 20 seconds, then release it. If the pilot goes out, wait for five (5) minutes, then repeat from step 1.
5. When the pilot is established, push the tap in again and turn it counter-clockwise to the full flame position, thus lighting the main burner.
6. If pilot becomes extinguished, turn main burner valve to the off position (fully counterclockwise) and wait five (5) minutes before relighting.

Shutdown, Broiler Preheat, and Grid Height Adjustment

1. **Standby:** To turn off, rotate main burner valve handles clockwise to the ignition position.
2. **Complete:** To shut the burner and pilot off, turn the dial to the “●” symbol and the safety device will disengage within 60 seconds.

IMPORTANT: NEVER THROTTLE THE BURNER DOWN. OPERATE BURNER IN FULL ON POSITION.

PREHEAT TIME— Allow at least five (5) minutes after turning the broiler on from cold, before loading the broiler with food to be cooked.

Check the grease container and drain frequently during heavy use to prevent overflow.

Grid Height Adjustment

Depress black ball and move lever up or down to desired cooking height, Figure 9.

OVENS

The temperature is automatically controlled by the thermostat so that satisfactory cooking can be repeated. For the best performance, the following instruction should be followed:

GRID SHELVES—There are three shelf positions. The shelf position is governed by the size of the product to be cooked. Always push the shelf back into the oven until it stops by making contact with the rear of the oven.

TRAY SIZE—A cake tray may be used on each shelf. Single trays or dishes must not be allowed to overhang the shelf in any direction, since this will adversely affect the heat circulation.

PREHEAT TIME—Allow at least 30 minutes after turning the oven on from cold, with the thermostat set at the desired temperature before loading the oven with food to be cooked. Put the food in quickly and close the door.

LIGHTING THE OVEN

To light the oven:

1. Push in the main oven/pilot tap and turn it counter-clockwise to the ignition position.
2. Holding the tap in fully, depress the ignitor button and observe that the pilot lights. If it does not, repeatedly depress the ignitor button until it does.
3. When the pilot is lit, continue to hold the tap fully in for 20 seconds, then release it. If the pilot goes out, wait for five (5) minutes then repeat from step 1.
4. When the pilot is established, push the tap again and turn it counter-clockwise to the full flame position "260°C". Then the set thermostat to the desired temperature.
5. To shut the burner off, turn the dial to the "●" position and the safety device will disengage within 60 seconds.

GENERAL MAINTENANCE

GENERAL CLEANING

WARNING!
THE BROILER AND ITS PARTS ARE HOT.
USE CARE WHEN OPERATING, CLEANING
OR SERVICING THE UNIT.

Lint and grease suspended in the air tend to collect in passages. Therefore, air openings, flueways, and primary air openings, etc., should be periodically cleaned to prevent clogging. The entire broiler should be given a periodic cleaning.

Daily

Remove grid racks, drip deflector (below grid rack), drip tray, and grease container. Thoroughly wash with mild detergent or soap. Excessive grease buildup may be removed by using a mildly abrasive cleaner.

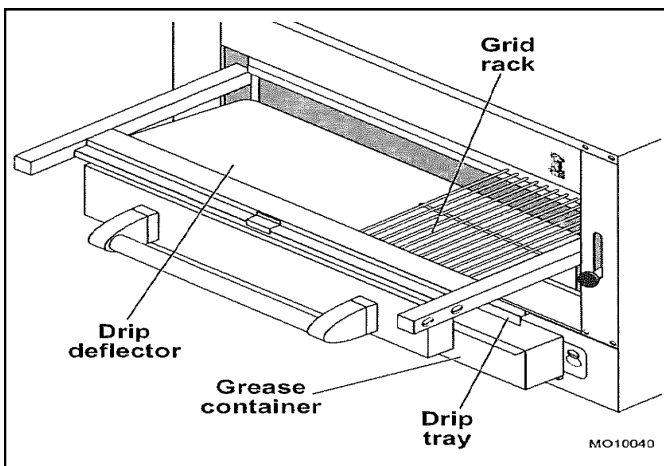

Figure 11. Items to be Cleaned Daily

PAINTED SURFACES

Exterior

Allow the broiler to cool down before cleaning exterior surfaces. Painted surface should be cleaned using a mild soap and warm water solution on a sponge or soft cloth.

Interior

Clean interior using a mildly abrasive cleanser with a damp cloth or nylon cleaning pad.

STAINLESS STEEL SURFACES

To remove dirt, grease or product residue from stainless steel, use ordinary soap and water (with or without detergent) applied with a sponge or cloth. Dry thoroughly with a clean cloth.

To remove grease and food splatter, or condensed vapors that have baked on the equipment, apply cleanser to a damp cloth or sponge and rub cleanser on the metal in the direction of the polishing lines on the metal. Rubbing cleanser as gently as possible in the direction of the polished lines will not mar the finish of the stainless steel. **NEVER RUB WITH A CIRCULAR MOTION.**

Soil and burnt deposits which do not respond to the above procedure can usually be removed by rubbing the surface with SCOTCH-BRITE scouring pads or STAINLESS scouring pads. **DO NOT USE ORDINARY STEEL WOOL** as any particles left on the surface will rust and further spoil the appearance of the finish. **NEVER USE A WIRE BRUSH, STEEL SCOURING PADS (EXCEPT STAINLESS), SCRAPER, FILE OR OTHER STEEL TOOLS.** Surfaces which are marred collect dirt more rapidly and become more difficult to clean. Marring also increases the possibility of corrosive attack.

To remove heat tint:

Darkened areas sometimes appear on stainless steel surfaces where the area has been subjected to excessive heat. These darkened areas are caused by thickening of the protective surface of the stainless steel and are not harmful. Heat tint can normally be removed by the procedures described above. Heat tint which does not respond to this procedure calls for a vigorous scouring in the direction of the polish lines, using SCOTCH-BRITE scouring pads or a STAINLESS scouring pad in combination with a powdered cleanser. Heat tint action may be lessened by not applying or by reducing heat to equipment during slack periods.

VENTILATION

The area in which the appliance is installed must be adequately ventilated to provide air for combustion, removal of products of combustion and removal of steam, etc. The use of a mechanical extract system should be considered.

SERVICING

To ensure efficient and safe operation of the appliance, it is recommended that servicing is carried out at regular intervals, the frequency of which will vary depending on the installation conditions and usage (usually once per year is adequate).

Servicing must be carried out by competent persons in accordance with the law.

SAFETY

It is essential that the instructions in this booklet are strictly followed for the safe and economical operation of the equipment. If it is known or suspected that a fault exists on the appliance, then it must not be used until the fault has been rectified by a competent person.

WARNING! If not installed, operated, and maintained in accordance with the manufacturer's instructions, this product could expose you to substances in fuel or in fuel combustion which can cause death or serious illness, and which are known to the State of California to cause cancer, birth defects, or other reproductive harm.

WARNING!

All personnel in the workplace who may be subject to any exposure of carbon monoxide must be warned of such possible exposure. This warning should be conveyed in a manner so that it is clearly understood by the employee, and the employee should be asked if in fact he or she understands the correct method of operation of the equipment and that a risk of exposure exists if the equipment is operated improperly.

SERVICERS AND NECESSARY REPLACEMENT PARTS CAN BE OBTAINED BY CONTACTING:

**HAVERICK MEATS
PO BOX 13
13-15 GREEN STREET
BANKSMEADOW
NSW 2019
AUSTRALIA**

TEL: +61 2 9316 8900

FAX: +61 2 9316 6034

EMAIL: info@haverickmeats.com.au

C36 & C45 EXPLODED VIEW

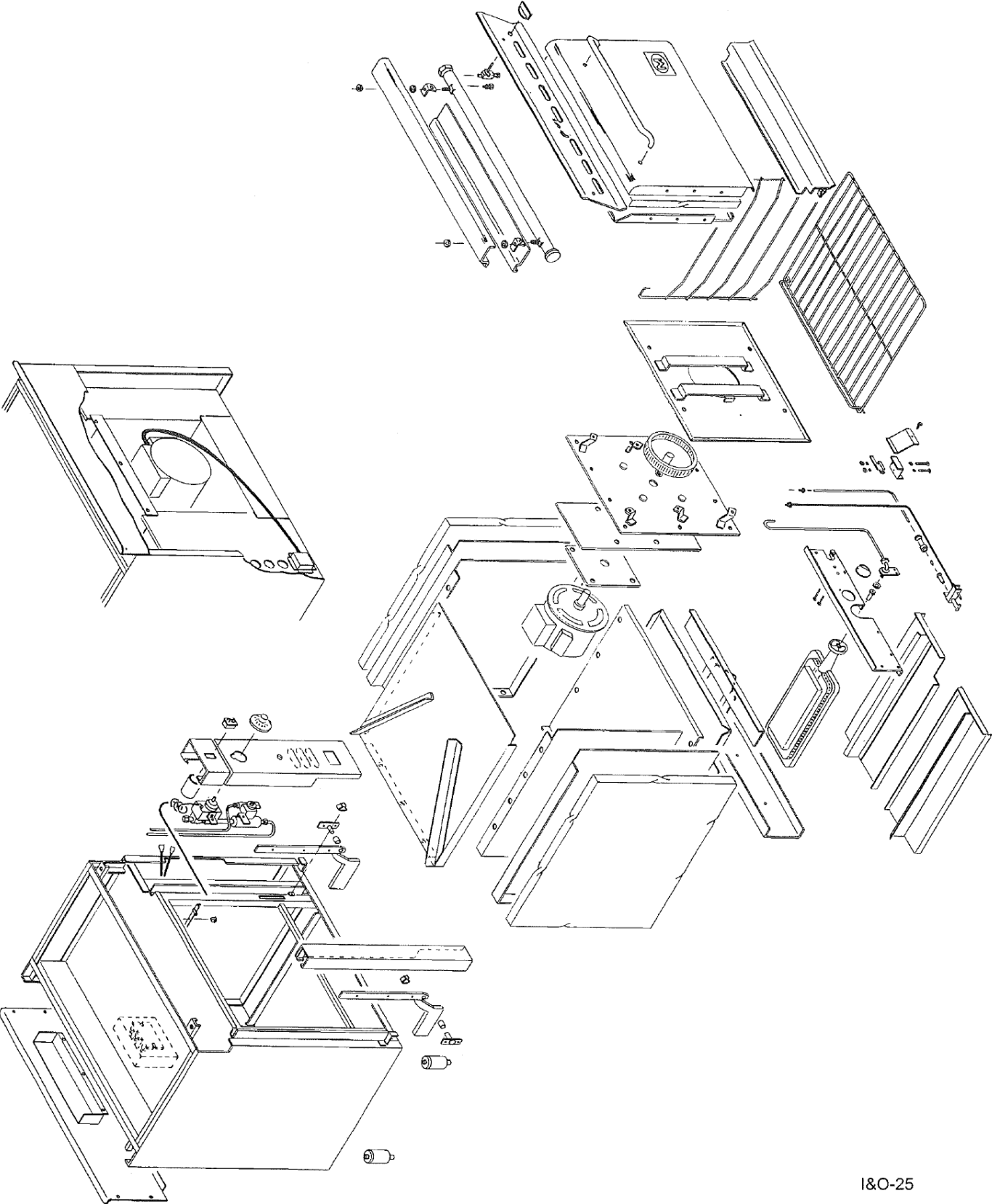

ITEM	PART NUMBERS		DESCRIPTION
	C36 236W36	C45 243W36	
1	2033-8	2033-8	KNOB, BLACK BALL
2	3504-1	3504-1	HANDLE, SLEEVE
3	1600-4	1600-4	GRID IRON, RIGHT
4	N/A	1602-0	GRID IRON, CENTER
5	1601-2	1601-2	GRID IRON, LEFT
6	43476-0	43476-0	HANDLE, VALVE
7	11611-4	11611-4	CERAMIC, LARGE
7A	28387-8	28387-8	CERAMIC KIT (10 ea. 11611-4 Large Ceramics, 4 ea. 11614-9 Ceramic Insulators)
8	11614-9	11614-9	INSULATOR, CERAMIC

36W36 & 43W36 EXPLODED VIEW

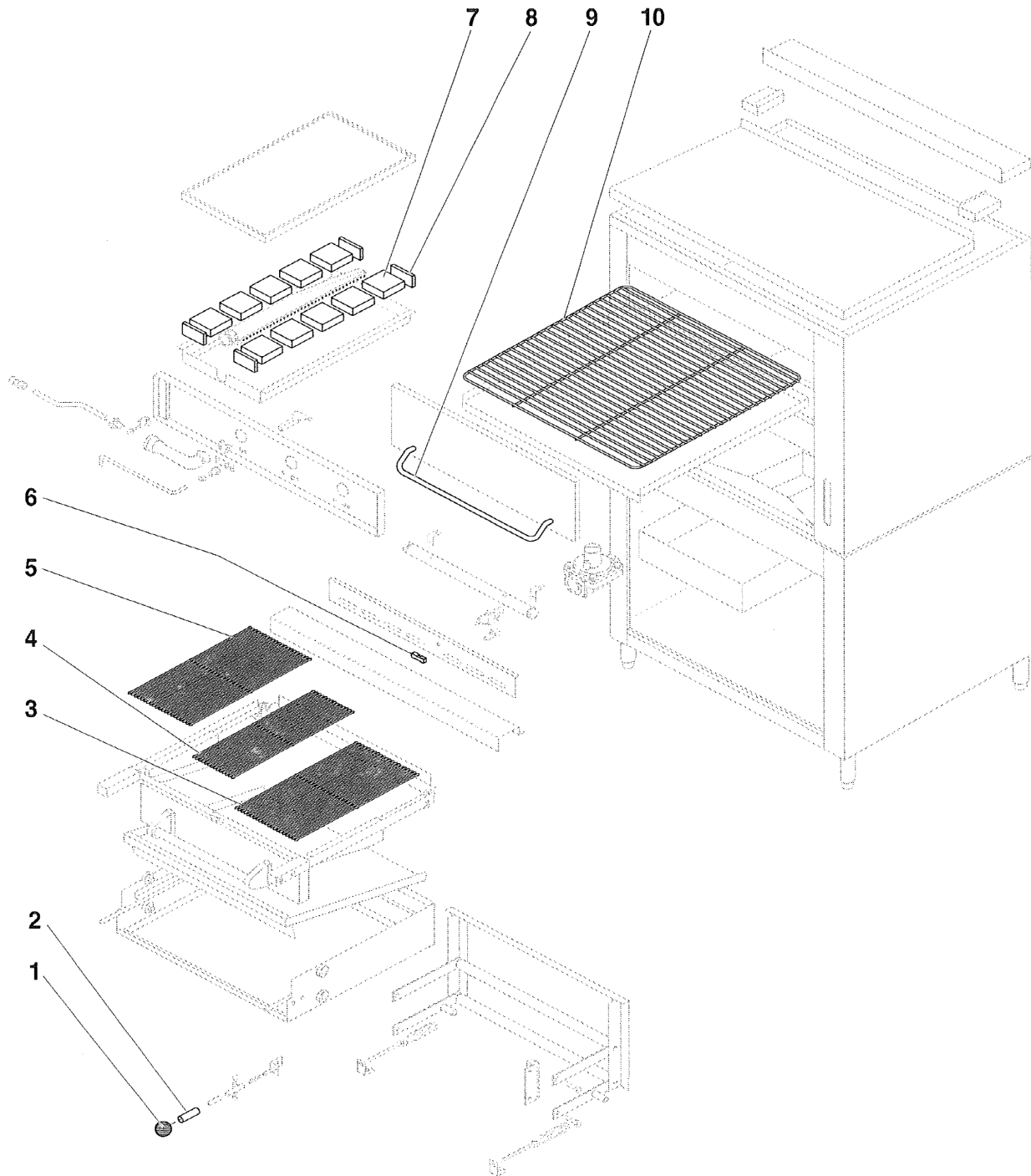

ITEM	PART NUMBERS		DESCRIPTION
	36W36	43W36	
1	2033-8	2033-8	KNOB, BLACK BALL
2	3504-1	3504-1	SLEEVE
3	1601-2	1601-2	GRID IRON, RIGHT
4	N/A	1602-0	GRID IRON, CENTER
5	1601-2	1601-2	GRID IRON, LEFT
6	43476-0	43476-0	HANDLE, VALVE
7	11611-4	11611-4	CERAMIC, LARGE
7A	28387-8	28387-8	CERAMIC KIT (10 ea. 11611-4 Large Ceramics, 4 ea. 1 1614-9 Ceramic Insulators)
8	11614-9	11614-9	INSULATOR, CERAMIC
9	3173-9	3173-9	HANDLE
10	1604-7	1579-2	WIRE RACK

Montaque E136 Series Heavy Duty Range Parts List

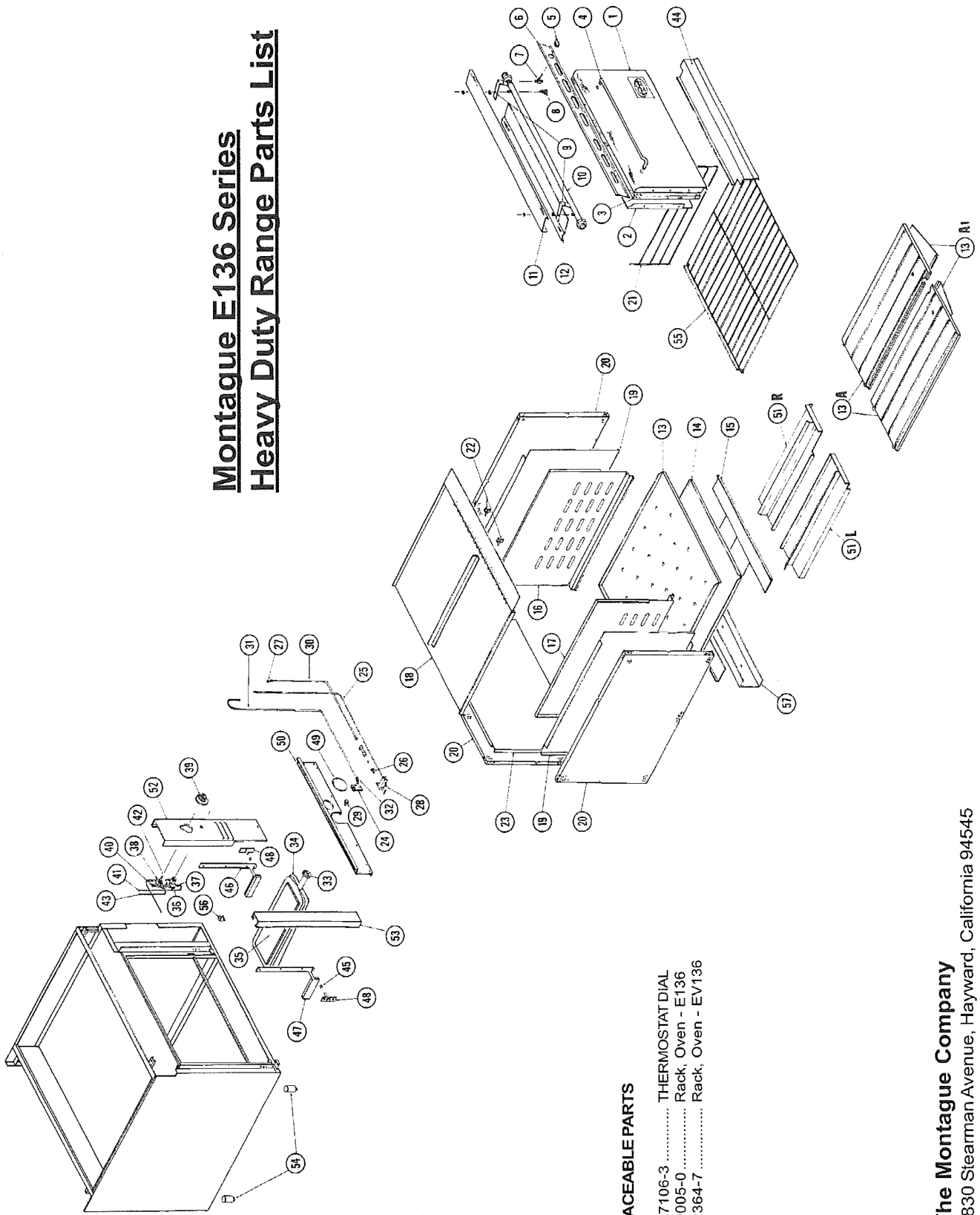

USER REPLACEABLE PARTS

- 39 THERMOSTAT DIAL
- 55 Rack, Oven - E136
- 55 Rack, Oven - EV136



The Montaque Company
1830 Stearman Avenue, Hayward, California 94545

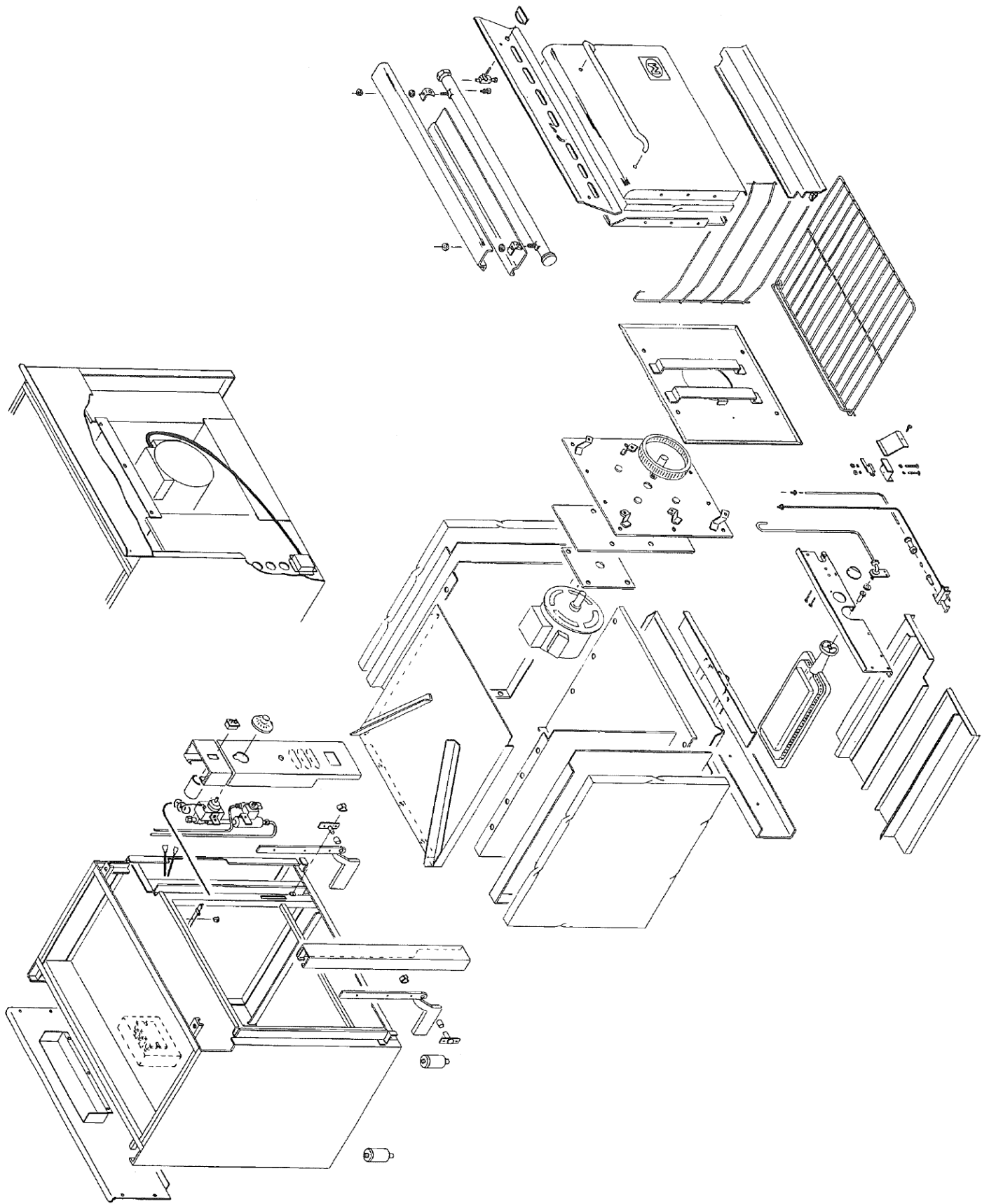

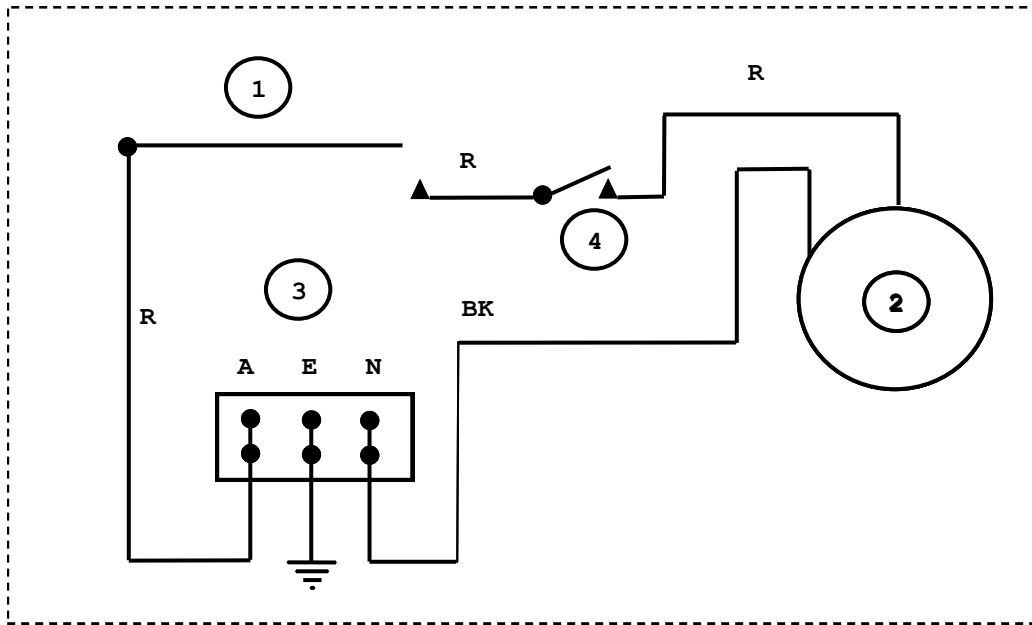

WIRE DIAGRAM
 EV136-AUSTRALIA
 240V 50HZ, 1PH

ITEM	DESCRIPTION
1	SWITCH, FAN
2	MOTOR
3	TERMINAL BLOCK
4	SWITCH, DOOR

WIRE-TYPE: SIZE 18 GA, 200°C

REPLACEMENT WIRES MUST BE OF SAME TYPE OR EQUIVALENT AS ORIGINAL.

02-13-09 REV A 46527-5

PARTS REMOVAL AND REPLACEMENT PROCEDURES

Perform the following procedures to remove and replace parts. To eliminate mistakes when ordering parts, always provide the following information:

- Model Number
- Serial Number

These numbers are located on the nameplate.

CAUTION: Turn off the broiler gas valve and allow broiler to cool before removing any components.

THIS APPLIANCE, WHEN INSTALLED, MUST BE ELECTRICALLY GROUNDED IN ACCORDANCE WITH LOCAL CODES. THIS APPLIANCE MUST BE INSTALLED WITH THE REQUIREMENTS OF AS5601 / AG601, LOCAL AUTHORITY, GAS, ELECTRICITY, AND ANY OTHER RELEVANT STATUTORY REGULATION.

COVERS AND PANELS

CAUTION: Turn off the gas supply at the manual shutoff valve that is next to the broiler before attempting to loosen any gas connections.

Venturi Cover

Removal of the Venturi cover provides access to the air shutter adjustments and main burner orifices.

1. Remove the two screws under the front edge of the Venturi cover.
2. Lift the Venturi cover from the broiler.

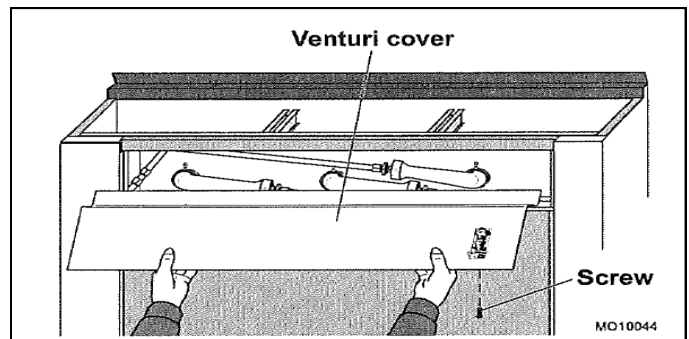

Figure 1. Venturi Cover

Control Panel Cover

Removal of the control panel cover provides access to the burner valves, pilot adjustment and carriage springs.

1. Turn the control valves to the full off position, then remove the control valve knobs.
2. Remove the two screws from the front of the control panel.

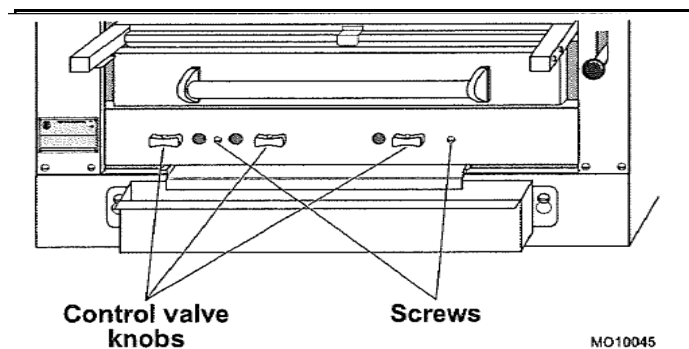

Figure 2. Control Panel Cover

DRIP DEFLECTOR

The drip deflector is located below the grid frame and is angled toward the back of the broiler. Grease dripping onto the drip deflector runs off the back edge to the drip tray, then flows forward into the horizontal grease container.

1. Pull the grid frame assembly forward to the stop.
2. Remove the grids from the frame assembly.
3. Lift the back edge of the drip deflector to disengage the drip deflector from the retaining latch.
4. Slide the drip deflector out at a downward angle.
5. When reinstalling the drip deflector, be sure to engage the front end under the retaining latch.

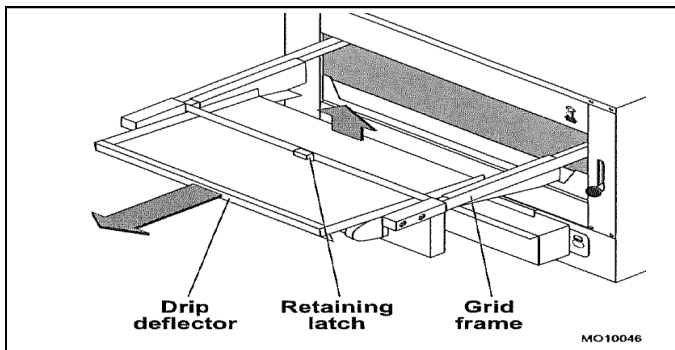

Figure 3. Drip Deflector

DRIP TRAY AND HORIZONTAL GREASE CONTAINER

The drip tray is located below the drip deflector. Grease dripping onto the drip deflector runs off the back edge to the drip tray then flows forward into the horizontal grease container.

1. Pull the drip tray straight out the front of the broiler.
2. Lift the horizontal grease container up and away from the broiler.

NOTE: When dumping the contents of the horizontal grease container, be sure to follow appropriate regulations for disposing of grease.

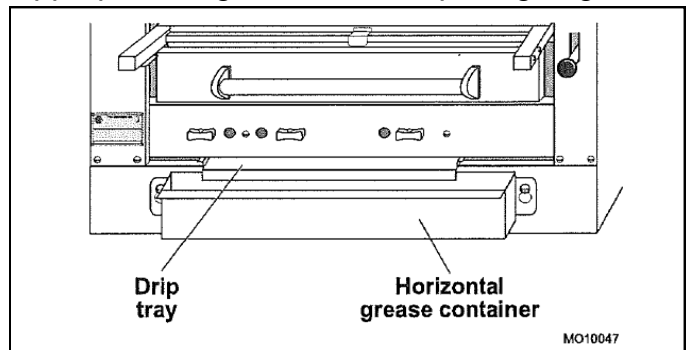

Figure 4. Drip Tray and Grease Container

CAUTION: Turn off the gas supply at the manual shutoff valve that is next to the broiler before attempting to loosen any gas connections.

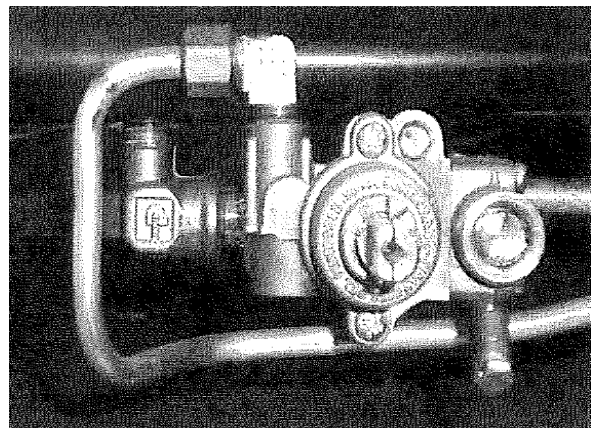

Figure 5. Flame Failure Valve

PILOT ASSEMBLY AND INJECTOR

The pilot assembly is located adjacent to each burner. The connection for the pilot assembly is accessed through the opening of the broiler compartment.

CAUTION: Turn off the gas supply at the manual shutoff valve that is next to the broiler before attempting to loosen any gas connections.

1. Remove the Venturi cover as described in COVERS AND PANELS.
2. Disconnect gas line from back of pilot assembly.
3. Unscrew the two nuts attaching the pilot assembly and pilot assembly bracket.

NOTE: Check condition of the pilot injector and replace if damaged.

4. Install the new pilot assembly, orifice and pilot assembly bracket.
5. Connect the gas line to the back of the pilot assembly.

NOTE: Make sure that the pipe joint compound or pipe thread sealant that is being used is resistant to the corrosive actions of liquefied petroleum gases.

6. Turn the main gas shutoff valve to the broiler to the ON position.

WARNING! All gas joints disturbed during servicing must be checked for leaks. Check with a soap and water solution (bubbles). DO NOT use an open flame.

7. Light pilot.
8. Reinstall Venturi cover, heat shield, insulation and exterior top.

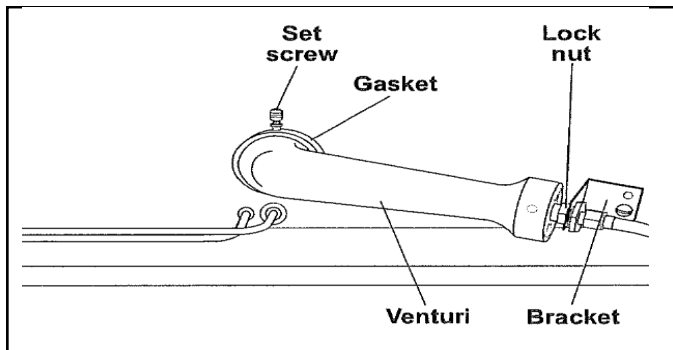

Figure 6. Pilot Assembly Connection

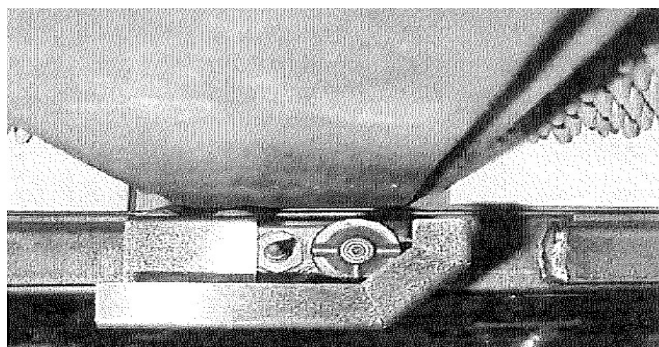
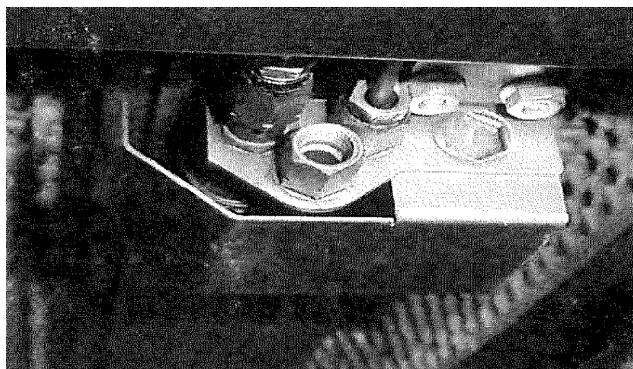

Figure 7. Pilot Assembly



MAIN BURNERS

The connection for the burners is accessed by removing the Venturi cover. The burners are accessed by removing the grids and carriage. The burner valves are accessed by removing the control panel cover.

CAUTION: Turn off the gas supply at the main shutoff valve that is next to the broiler before attempting to loosen any gas connections.

Burner Assembly, Orifice, and Venturi

1. Remove the Venturi cover as described in **COVERS AND PANELS**.
2. Remove the ceramic radiants from each side of the main burner to be replaced.
3. Loosen the set screw that attached the main burner to the Venturi assembly.
4. Slide the main burner out of the broiler.
5. If the Venturi or orifice is to be replaced, disconnect the gas input to the Venturi. Remove the gasket. Replace the gasket every time the Venturi or burner is removed.
6. Loosen the lock nut so that the Venturi can be removed from the bracket.

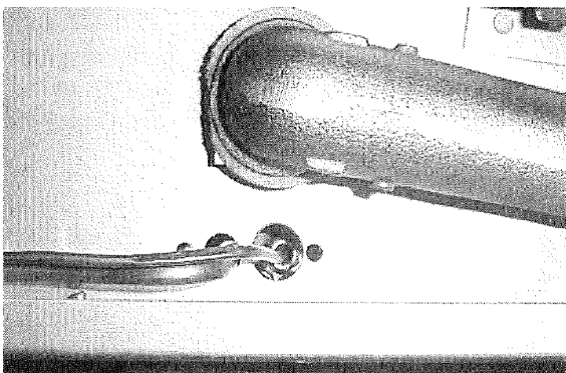

Figure 8. Burner pilot assembly

7. Remove the orifice hex nut fitting from the Venturi.
8. Remove the orifice from the hex nut fitting.

NOTE: Make sure the pipe joint compound or pipe thread sealant that is being used is resistant to the corrosive actions of liquefied petroleum gases.

9. Reassemble by reversing procedure.

WARNING!

All gas joints disturbed during servicing must be checked for leaks. Check with a soap and water solution (bubbles). DO NOT use an open flame.

Figure 9. Orifice Assembly

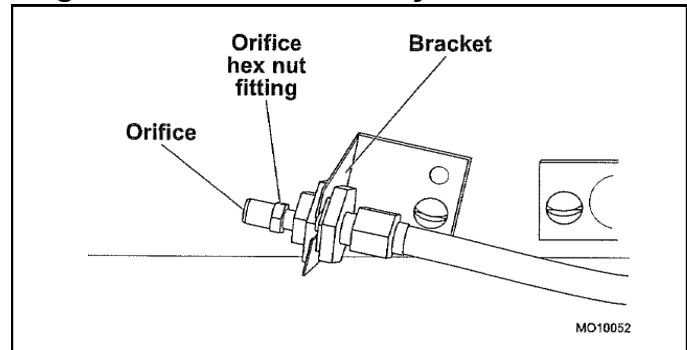

Burner Valve Removal/Replacement

The burner valves are located on the manifold behind the control panel cover.

CAUTION: Turn off the gas supply at the manual shutoff valve that is next to the broiler before attempting to loosen any gas connections.

1. Remove the control panel cover as described under **COVERS AND PANELS** to access the burner valve.
2. Disconnect the gas line, pilot line, and thermocouple from the back of the burner valve.
3. Unscrew the burner valve from the manifold.
4. Install the new burner valve.

NOTE: Make sure that the pipe joint compound or pipe thread sealant that is being used is resistant to the corrosive actions of liquefied petroleum gases.

5. Connect the gas line, pilot line, and thermocouple to the back of the valve.
6. Turn the main gas shutoff valve to the broiler to the ON position.

WARNING!

All gas joints disturbed during servicing must be checked for leaks. Check with a soap and water solution (bubbles). DO NOT use an open flame.

7. Light pilot
8. Reinstall the control panel cover and control valve knobs.
9. Turn burner valve full on and check that burner is properly lit.

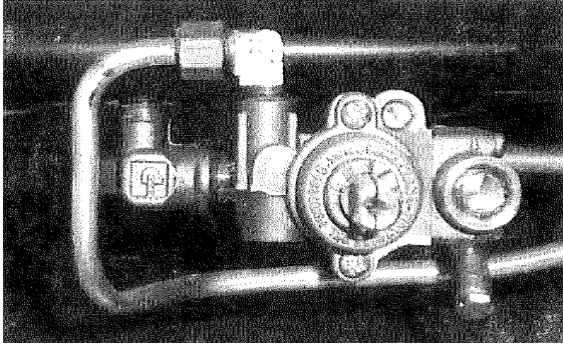

Figure 10. Burner Valve

CARRIAGE POSITION HANDLE

The carriage position handle consists of the parts shown in the following illustration and parts list.

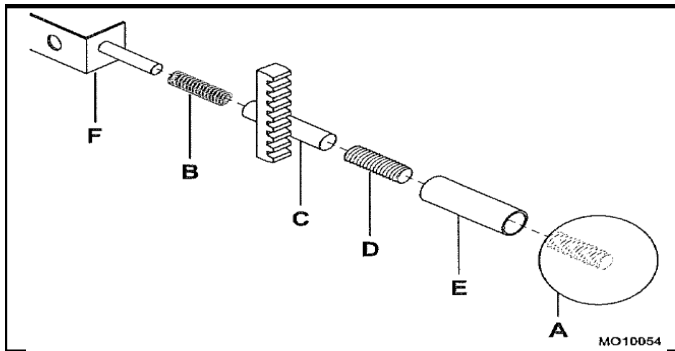

Figure 11. Carriage Position Handle

Item	Part No.	Description	Qty
A	02033-8	Knob, Black Ball	1
B	32756-5	Compression Spring	1
C	03503-3	Gear & Tube Assembly	1
D	03506-8	Stud, Threaded	1
E	03504-1	Sleeve, Chrome	1
D	14442-8	Handle Bracket	1

Black Ball Knob

1. Remove the black ball knob by unscrewing it (counterclockwise) from the threaded stud.
2. Replace the black ball knob by screwing it

(clockwise) onto the threaded stud.

Chrome Sleeve

1. Turn off the burners.
2. Allow the broiler to cool to room temperature.
3. Remove the black ball knob by unscrewing it (counterclockwise) from the threaded stud.
4. Remove the sleeve from the tube/threaded stud assembly.
5. Replace the chrome sleeve by placing the sleeve onto the threaded stud.

Threaded Stud

1. Turn off the burners.
2. Allow the broiler to cool to room temperature.
3. Remove the black ball knob by unscrewing it (counterclockwise) from the threaded stud.
4. Remove the chrome sleeve from the tube/threaded stud assembly.
5. Unscrew the threaded stud from the tube.
6. Reinstall the threaded stud by performing the above steps in reverse order. Screw the threaded stud about 1" into the threaded end of the tube.

Gear and Tube Assembly

1. Turn off the burners.
2. Allow the broiler to cool to room temperature.
3. Remove the black ball knob by unscrewing it (counterclockwise) from the threaded stud.
4. Remove the chrome sleeve.
5. Unscrew the threaded stud from the tube.
6. Remove gear with bracket from the cabinet frame.
7. Slide the gear and tube assembly off the carriage position handle arm.
8. Replace the gear and tube assembly by

Compression Spring

1. Turn off the burners.
2. Allow the broiler to cool to room temperature.
3. Remove the black ball knob by unscrewing it (counterclockwise) from the threaded stud.
4. Remove the chrome sleeve.
5. Remove the threaded rod.
6. Remove the spring from the tube and gear assembly using needle nose pliers.
7. Replace the compression spring by performing the above steps in reverse order.

Gear with Bracket

1. Turn off the burners.
2. Allow the broiler to cool to room temperature.
3. Raise grill to the top.
4. Remove all components of carriage position handle.
5. Remove the two screws and nuts that hold the gear with bracket to the vertical frame rail.
6. Replace the gear with bracket by performing the above steps in reverse order.

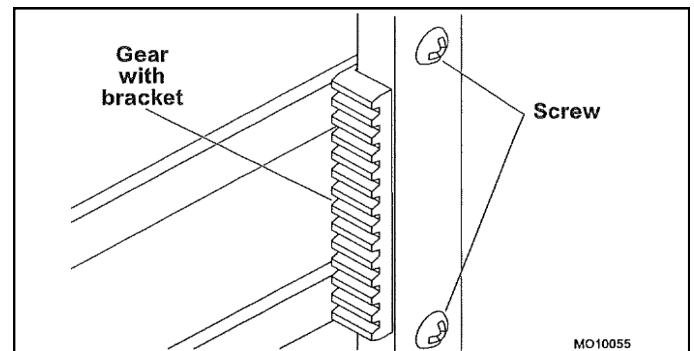

Figure 12. Gear with Bracket

SERVICE AND ADJUSTMENT PROCEDURES

Regular maintenance by a competent person is recommended to ensure the continued safe and efficient performance of the appliance.

Should service be required, kindly contact your dealer for assistance. Alternately, please contact us at the following address:

HAVERICK MEATS
PO BOX 13, 13-15 GREEN STREET
BANKSMEADOW, NSW 2019
Telephone: +61 2 9316 8900
Fax: +61 2 9316 6034 - info @haverickmeats.com.au

WARNING! TURN OFF THE GAS SUPPLY TO THE APPLIANCE AT THE SERVICE COCK BEFORE COMMENCING ANY SERVICING WORK.

IMPORTANT: Test for gas soundness on completion of any servicing work. These instructions are intended for use by competent service personnel.

GAS PRESSURE REGULATOR ADJUSTMENT PROCEDURE

DO NOT allow untrained personnel to maintain or service the gas pressure regulator.

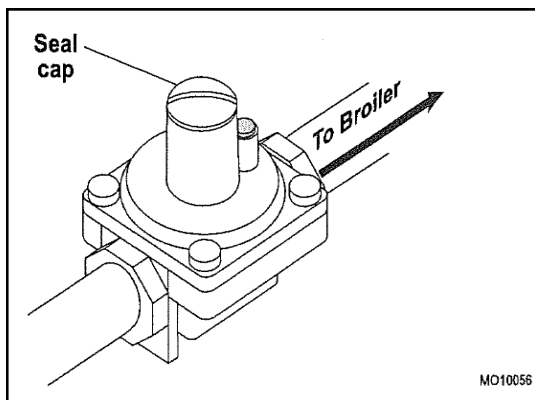

Figure 13. Gas Pressure Regulator

1. Before adjusting the regulator, check the incoming gas line pressure. Incoming pressure before the regulator must be 1.0 kPa for natural gas, or 2.75 for propane.
2. If incoming pressure is not correct, have the gas source checked and adjusted as necessary.
3. Make sure that the regulator is mounted in the horizontal position with the arrow pointing in the direction of the gas flow.
4. Connect a manometer to the pressure tap provided on the manifold between the regulator and the burner valves.
5. Check the manometer reading. The reading must be 1.0 kPa for natural gas, or 2.75 kPa for propane.
6. If incoming line pressure is not correct, adjust the regulator. Remove seal cap on top of the regulator.
7. Insert a blade-type screw driver into the top hole of the regulator.
8. Turn the adjustment screw clockwise to increase the pressure, or counterclockwise to decrease the pressure.
9. While watching the manometer, turn the adjustment screw to set proper Regulator outlet pressure.

PILOT BURNER CLEANING AND INSPECTION PROCEDURE

1. Light the pilot burner as described in the *Installation and Operation* section of this manual.

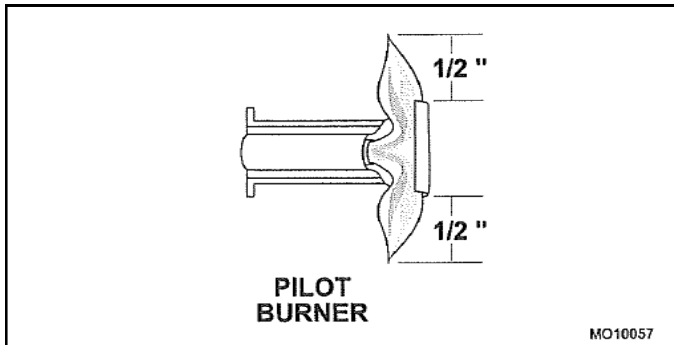

Figure 14. Pilot Burner

2. If the pilot burner flame burns yellow, clean the pilot injector and the pilot burner in order to ensure a steady blue flame. Clean by blowing through or washing. **DO NOT** use wire to clear the pilot injector.
3. If the pilot burner flame still burns yellow, replace the pilot burner and injector.
4. If the pilot flame does not extend 1/2" beyond the outer edges of the pilot, further inspection is necessary.

GAS TAPS

Re-greasing of the taps is not recommended. If the tap spindles become seized or difficult to turn, refer to the *Replacement of Parts* section in this manual.

CLEANING BURNER HEADS

1. Remove top panel.
2. Remove top liner panel with insulation.
3. Remove ceramic radiants from the burner frame assembly.
4. Remove screw from left end of burner head.
5. Loosen thumb screw holding burner Venturi in place.
6. Remove burner head.
7. Clean the burner with a stiff scrubbing brush and shake well to ensure that the ports are clear of any debris.
8. Reassemble in the reverse order.

CLEANING BURNER VENTURI

1. Remove top panel.
2. Remove right control panel.
3. Disconnect injector fitting and remove.
4. Loosen thumb screw and slide Venturi out of the burner head.
5. Clean the Venturi in hot soapy water with a stiff brush.
6. Rinse and shake well to remove any debris.
7. Reassemble in the reverse order.

CARRIAGE POSITION HANDLE ADJUSTMENT PROCEDURE

The carriage position handle can be placed in a number of vertical positions.

1. Grasp the black ball knob and press it in toward the front control panel.
2. Raise or lower the carriage assembly to the desired height.
3. Release pressure on the black ball knob to lock the carriage assembly at the desired height.

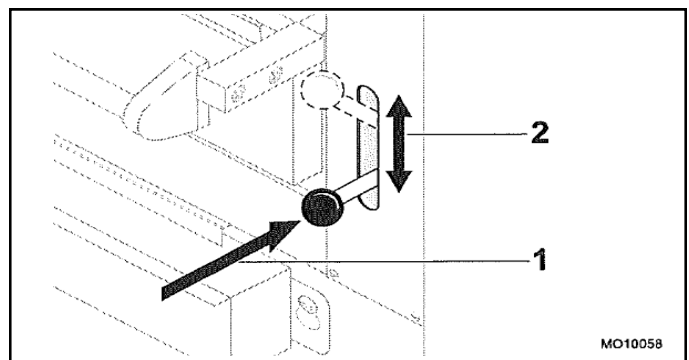

Figure 15. Carriage Position Handle

HANDLE TENSION ADJUSTMENT

If carriage is difficult to move or will not stay in place, the handle tension requires adjusting.

1. Remove black ball knob and chrome sleeve.
2. Turn threaded knob to the left to increase tension; turn to the right to decrease tension.

CARRIAGE TENSION SPRING ADJUSTMENT PROCEDURE

Carriage Adjustments should be made with the grid irons in place and allowance for product weight.

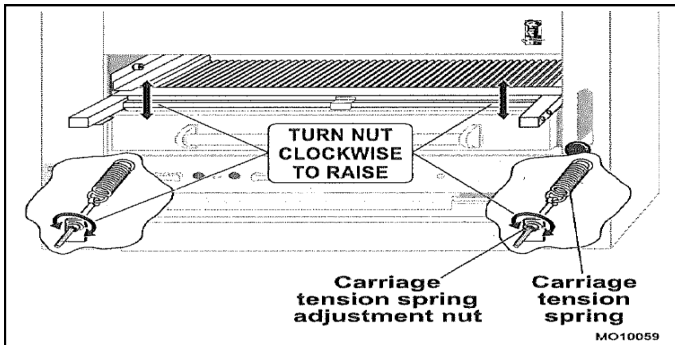

Figure 16. Carriage Tension Spring

1. Locate the carriage tension spring adjustment nut. The adjustment nut is accessible from the front as follows:

Model Nos. E36W36 and E43W36:
Through lower compartment.

Model Nos. E136W36 and EV136W36:
Behind valve panel.

Model Nos. EC36, EC45, E236W36 and E243W36:
Behind left and right front panels.

2. Turn nut clockwise to increase tension or counterclockwise to decrease tension.
3. If one side of the grid is lower than the other side, turn the adjustment nut on the low side clockwise to level the grid.

MISCELLANEOUS

1. Wire brush the surface of the grid to remove baked on material, wash with hot water, dry thoroughly and reassemble.
2. Clean out the grease container and wash with hot soapy water. Dry thoroughly.
3. Wipe exposed cleanable surfaces with a mild detergent and hot water. Stubborn residue may be removed with a lightweight non-metallic scouring pad. Stainless steel areas should be washed with a mild detergent, hot water and a soft cloth. If necessary to use a non-metallic scouring pad, always rub in the direction of the grain in the metal to prevent scratching. **NEVER USE STEEL WOOL.**
4. Check the operation of the thermocouple and flame safety devices by lighting the pilot and then blowing it out. Listen for the flame failure valve clicking closed. This action must occur within 60 seconds of extinguishing the pilot.

OVEN MINIMUM FLAME SETTING

This is the flame that must be maintained on the burner when the oven has come up to the temperature set on the dial. Enough gas must be bypassed by the control to keep the entire burner lit. The thermostat regulates the flame from high to low in accordance with the oven temperature and will automatically turn down to this minimum flame when the temperature set on the dial is attained in the oven.

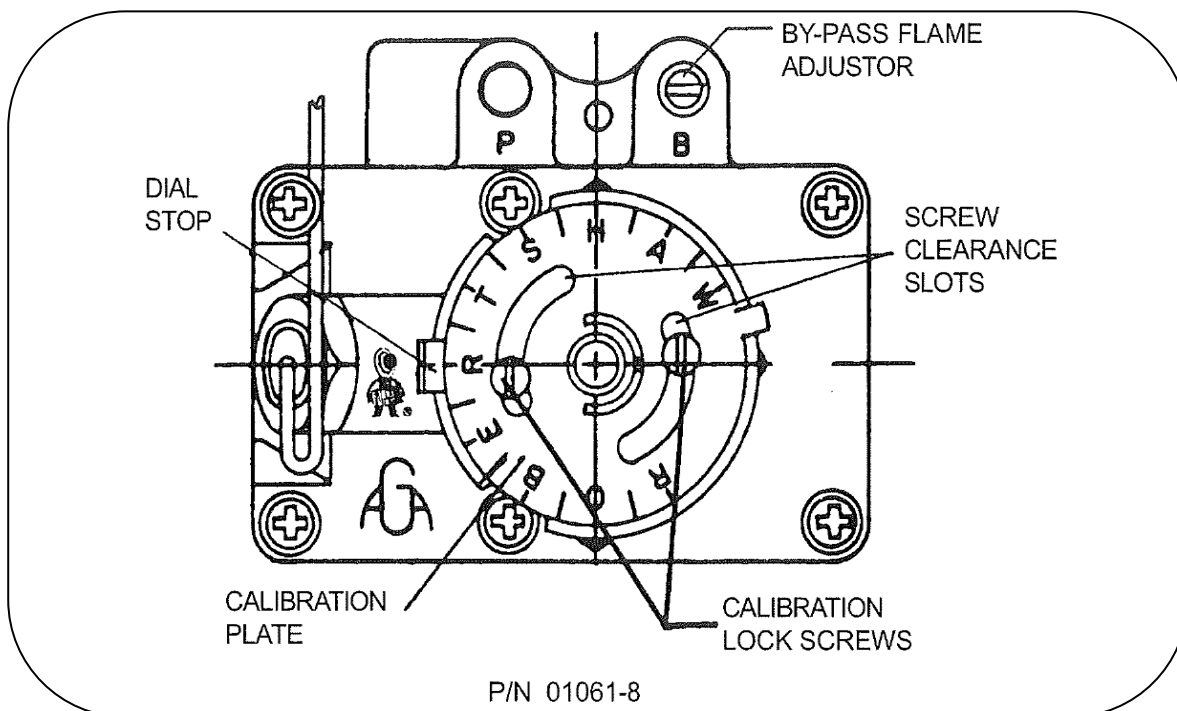

1. Light the oven, set thermostat to 100°C and allow 5 minutes for the oven temperature to stabilize.
2. After oven temperature rises and remains constant, turn dial back to low. This closes the main valve and permits only the bypass gas to the burner.
3. Remove dial.
4. With a screwdriver, turn the bypass flame adjustor screw counterclockwise to increase the bypass flame or clockwise to decrease it until the flame over the entire burner is approximately 4mm high. Replace dial.

THERMOSTAT CALIBRATION CHECK

The calibration of this thermostat should not be changed until considerable experience with cooking results has definitely proved that the thermostat is not maintaining the proper temperature. The recalibration should not be made until the bypass (minimum burner) flame has been properly adjusted.

If re-calibration becomes necessary, the following procedure should be followed:

1. Place the thermocouple of test instrument or thermometer in the middle of the oven.
2. Light the main burner.
3. Turn dial to between the "180" and the "200" position (190).
4. Allow the oven to heat until the flames cut down to bypass. After sufficient time, check temperature. If the temperature does not read within 10 degrees of the dial setting, recalibrate as follows:
 - A. Pull dial straight off without turning.
 - B. Hold calibration plate and loosen the two calibration lock screws until the plate can be moved independently of the control.
 - C. Turn calibration plate so that the instrument or thermometer reading is in line with the indicator mark. Hold plate and tighten screws firmly. Turn the calibration plate counter clockwise if the test reading is higher than the dial setting. Replace dial.

NOTE: If the above adjustment is prevented by the two loosened calibration lock screws being in contact with the ends of the screw clearance slots in the calibration plate, remove the screws and after turning the calibration plate to the proper location, reassemble screws in the other tapped holes designed for them.

OVEN

- A. Light pilot in accordance with the Lighting Instructions.
- B. Check that the length of the pilot flame is correct per table C.

All pilot flames should envelop the tip of the thermocouple. The pilot flame can be viewed through the opening in the front of the burner compartment panel.

Replace the burner access panel.

Hand the Instructions & Operation Manual to the user or purchaser for retention and instruct them in the efficient and safe operation of the appliance.

Tell the user of the location of the gas isolation cock for use in an emergency.

Leave this manual with the user or purchaser.

SAFETY AND PILOT BURNER INSPECTION

WHEN SERVICE IS NEEDED, CONTACT A LOCAL SERVICE COMPANY, DEALER, OR FACTORY TO PERFORM MECHANICAL MAINTANACE AND REPAIRS. THESE INSTRUCTIONS ARE INTENDED FOR USE BY COMPETENT SERVICE PERSONNEL.

CAUTION: TURN OFF GAS SUPPLY WHEN SERVICING GAS CONTROL SYSTEM.

SAFETY PILOT VALVE

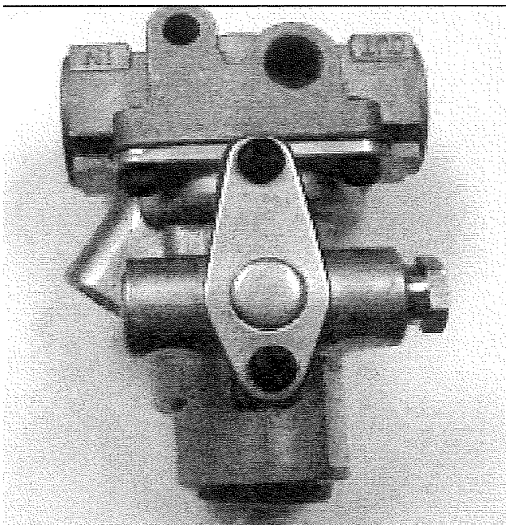

Model H15HR is an automatic 100% safety pilot which provides complete gas shut off in event of pilot failure. The safety valve is held closed by spring pressure. When red button is pushed by hand, gas flows to pilot. Pilot heats thermocouple creating a very small amount of electricity. This energizes a magnetic coil under the red button and holds valve open, permitting gas to flow to main burner and pilot holding pressure on red button. In the event of pilot failure, the flow of electricity will stop and spring will stop flow of gas to both pilot and oven burner.

OVEN PILOT BURNER PILOT SERVICE IN THE EVENT OF PILOT FLAME FAILURE

1. If pilot flame burns yellow, clean pilot orifice and pilot burner to insure a steady blue flame. The P/N 010138 orifice can be cleaned by Pilot Burner washing in a solvent and/or blowing out with air.
2. Flame must surround the thermocouple tip for approximately 1/2 inch.

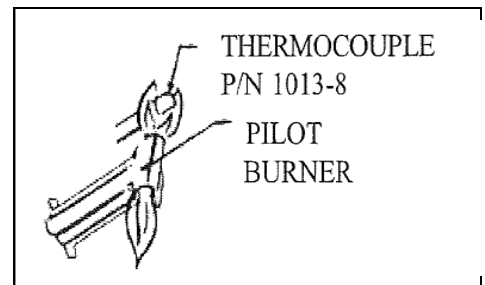

THERMOCOUPLE OUTPUT	
CLOSED CIRCUIT MV RANGE	
NORMAL	NOT LESS THAN
15-25	8

If the closed circuit check shows thermocouple output is greater than 8 millivolts and pilot will not remain lit when the reset button is released, replace safety pilot valve.

3. Thermocouple lead connections must be tight, clean, and free of grease. The thermocouple nut should be started and turned all the way by hand. An additional quarter turn with a small wrench will then be sufficient.

CAUTION: OVERTIGHTENING MAY CAUSE DAMAGE TO THE THERMOCOUPLE OR MAGNET AND IS UNNECESSARY SINCE THIS IS AN ELECTRIC CONNECTION.

OPERATIONAL DIFFICULTIES & PROBABLE CAUSES

OVEN PILOT BURNER GOES OUT:

1. Gas shut off.
2. Poor draft in flue snuffs out flame.
3. Too much draft pulls flame away from thermocouple.
4. Pilot flame too low.
5. Thermocouple defective.
6. Thermocouple connection on safety pilot loose.
7. Pilot orifice dirty.
8. Safety pilot valve defective.
9. Gas leak at pilot orifice fitting.
10. Restricted or plugged vent on gas pressure regulator.

OVEN BURNER FAILS TO COME ON (PILOT ON):

1. Burner valve off.
2. Burner orifice plugged.
3. Thermostat out of calibration.
4. Minimum flame adjustment closed and thermostat setting too low.

OVEN TEMPERATURE HIGHER THAN DIAL SETTING:

1. Oven thermostat out of calibration.
2. Minimum flame too high. (Do not lower under 1/8").
3. Broken capillary tube on thermostat.
4. Dirt under thermostat valve seat.

TROUBLESHOOTING CHART

SYMPTOM	CAUSE	REMEDY
Pilot burner flames are burning yellow.	Gas too rich. Clogged pilot air passages.	Perform the <i>PILOT BURNER CLEANING AND INSPECTION PROCEDURE</i> . Perform the <i>PILOT BURNER INJECTOR REMOVAL AND REPLACEMENT PROCEDURE</i> .
Pilot burner flames are less than or more than 1/2".	Low pressure. Clogged pilot burner.	Check manifold pressure. Replace pilot burner.
Burner flames burning yellow.	Incorrect gas pressure or primary air.	Check gas pressure. Adjust or clean air mixer.
One or more burner flames cannot be adjusted.	Dirty Venturi passage. Incorrect gas pressure. Ceramics cracked, broken, or missing. Faulty burner valve.	Perform the <i>CLEANING BURNER VENTURI PROCEDURE</i> . Check and adjust gas pressure. Replace damaged or missing ceramics, See <i>Installation & Operation</i> manual. Perform the <i>BURNER VALVE REMOVAL AND REPLACEMENT PROCEDURE</i> .
The heat of one or more burners is not uniform over the surface of the ceramic tiles.	Clogged burner ports. Broken or missing ceramics. Dirty Venturi passage. Wrong gas pressure.	Clean burner ports or perform the <i>MAIN BURNER REMOVAL AND REPLACEMENT PROCEDURE</i> . Replace broken or missing ceramics. Clean air mixer and Venturi. Check and adjust gas pressure.
Carriage assembly will not stay at a set height position.	Improper handle spring tension adjustment. Worn or broken gear with bracket.	Perform the <i>HANDLE TENSION ADJUSTMENT PROCEDURE</i> . Perform the <i>GEAR WITH BRACKET REMOVAL AND REPLACEMENT PROCEDURE</i> .
Carriage assembly moves up and down too easily or too hard.	Improper carriage spring tension adjustment.	Perform the <i>CARRIAGE TENSION SPRING ADJUSTMENT PROCEDURE</i> .

EC36 & EC45 EXPLODED VIEW

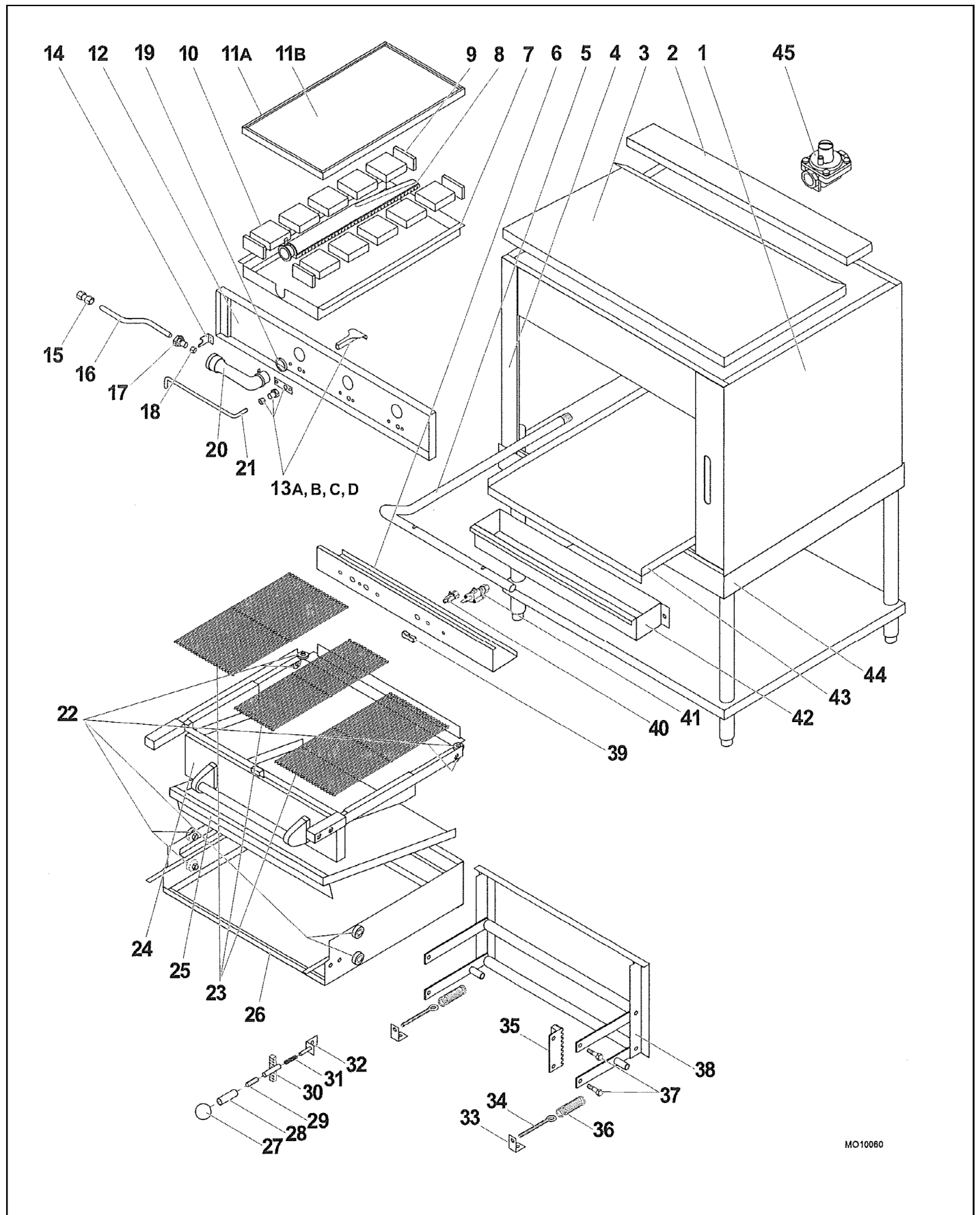

MO10060

ITEM	PART NUMBERS		DESCRIPTION
	EC36 E236W36	EC45 E243W36	
1	12925-9	12925-9	PANEL, RIGHT SIDE
2A	25442-8	25442-8	FLUE, RIGHT SIDE
2B	25440-1	25440-1	FLUE, LEFT SIDE
2C	12610-1	15391-5	FLUE DEFLECTOR
3	15355-9	15385-0	EXTERIOR TOP
4	12923-2	12923-2	PANEL, LEFT SIDE
5	42992-9	42992-9	MANIFOLD- FFV
6	43054-4	40566-3	VALVE CONTROL PANEL- FFV
7	42867-1	42867-1	FRAME, BURNER ASSEMBLY
8	26700-7	26700-7	BURNER w/ SET SCREW
9	11614-9	11614-9	INSULATOR, CERAMIC
10	11611-4	11611-4	CERAMIC, LARGE
10A	28387-8	28387-8	CERAMIC KIT (10 ea. 11611-4 Large Ceramics; 4 ea. 11614-9 Ceramic Insulators)
11A	15352-4	15383-4	HEAT SHIELD
11B	1430-3	1430-3	INSULATION
12	15182-3	15295-1	FIRE BOX FRONT ASSEMBLY
13A	41741-6	41741-6	PILOT ASSEMBLY w/ SHIELD
13B	26180-7	26180-7	PILOT INJECTOR - Natural Gas
13C	26181-5	26181-5	PILOT INJECTOR - G31
13D	26177-7	26177-7	THERMOCOUPLE - M9X1 X 1500MM
14	3397-9	3397-9	BRACKET, ORIFICE
15	1280-7	1280-7	UNION, TUBING
16	1252-1	1252-1	TUBING, STEEL, 7/16" OD 508MM
17	6378-9	6378-9	BURNER, ORIFICE HEX COMP. FITTING
18A	6150-6	6150-6	ORIFICE- NATURAL GAS
18B	6381-9	6381-9	ORIFICE- PROPANE GAS
19	20923-6	20923-6	GASKET, VENTURI
20	20924-4	20924-4	VENTURI, AIR MIXER ASSEMBLY
21	1224-6	1224-6	TUBING, ALUMINUM - 1/4" OD

ITEM	PART NUMBERS		DESCRIPTION
	EC36 E236W36	EC45 E243W36	
22	3396-0	3396-0	BEARING, w/ ASSEMBLY
23A	1601-2	1601-2	GRID, WIRE-LEFT; CHROME (PORCELAIN AVAILABLE)
23B	N/A	1602-0	GRID, WIRE-CENTER; CHROME (PORCELAIN AVAILABLE)
23C	1600-4	1600-4	GRID, WIRE-RIGHT; CHROME (PORCELAIN AVAILABLE)
24	38331-7	38040-7	GRID FRAME ASSEMBLY
25	15240-4	15328-1	DRIP DEFLECTOR
26	4655-8	4657-4	CARRIAGE ASSEMBLY
27	2033-8	2033-8	KNOB, BLACK BALL
28	3504-1	3504-1	HANDLE, SLEEVE
29	3506-8	3506-8	THREADED ROD
30	3503-3	3503-3	TUBE AND GEAR ASSEMBLY
31	32756-5	32756-5	SPRING, HANDLE
32	14442-8	14442-8	HANDLE ASSEMBLY BRACKET
33	15244-7	15244-7	CARRIAGE SPRING MTG BRACKET
34	1938-0	1938-0	EYE BOLT
35	3507-6	3507-6	GEAR w/ ANGLE BRACKET
36	34258-0	2034-6	CARRIAGE SPRING
37	28365-7	28365-7	CARRIAGE BOLT
38	13096-6	13101-6	STABILIZER UNIT ASSEMBLY
39	43476-0	43476-0	VALVE HANDLE w/o RING
40	40415-2	40415-2	FLAME FAILURE VALVE ASSY
40	43475-2	43475-2	FLAME FAILURE VALVE (NO FITTINGS)
42A	6604-4	6604-4	HORIZONTAL GREASE CONTAINER - PTD
42B	6603-6	6603-6	HORIZONTAL GREASE CONTAINER - S/S
43	15246-3	15366-4	DRIP TRAY
44	39097-6	40899-9	STAND, MODULAR- S/S
45A	14605-6	14605-6	GAS PRESSURE REGULATOR - NATURAL GAS
45B	1040-5	1040-5	GAS PRESSURE REGULATOR - PROPANE GAS

E36W36 & E43W36 EXPLODED VIEW

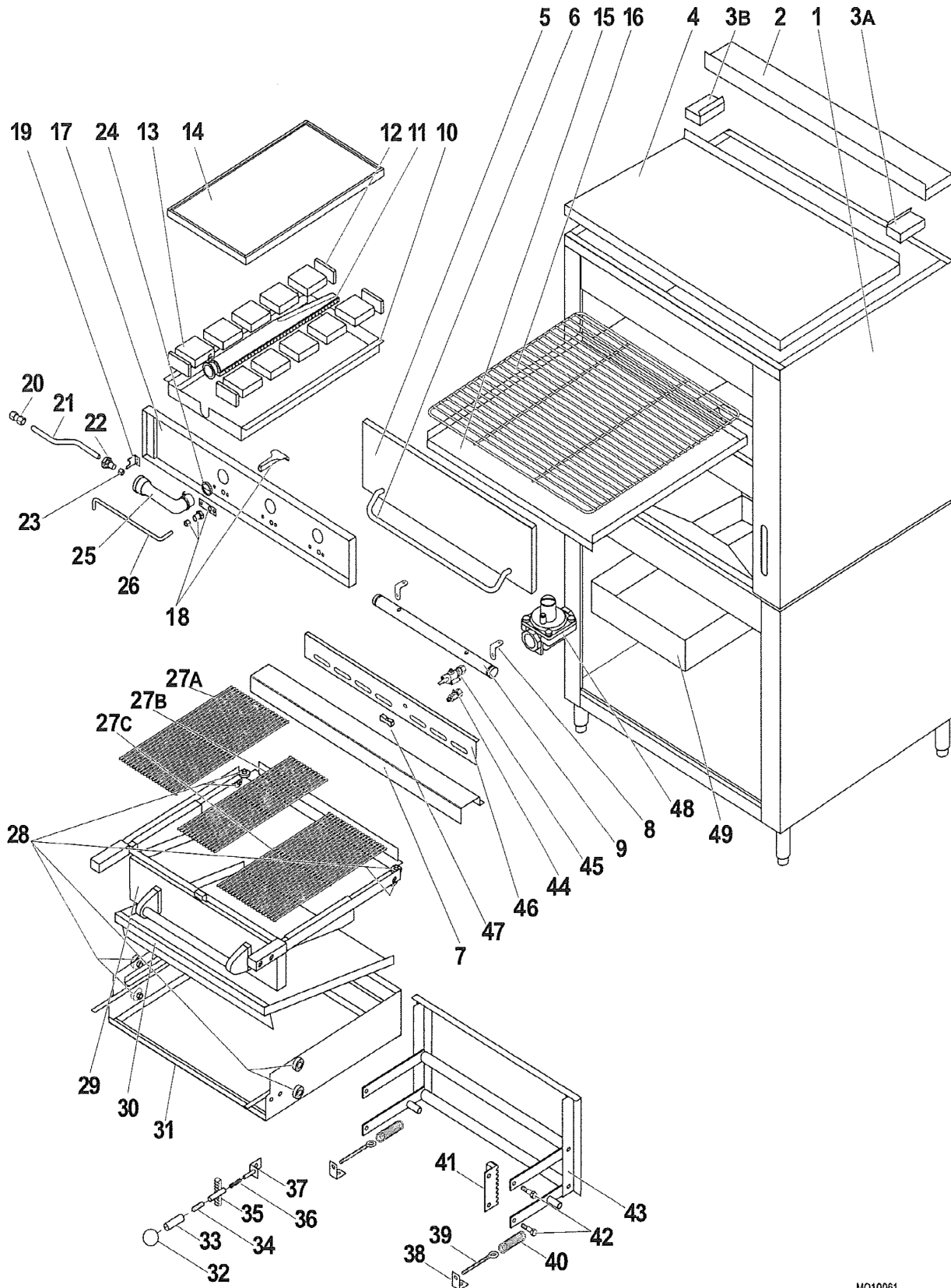

M010061

ITEM	PART NUMBERS		DESCRIPTION
	E36W36	E43W36	
1	15168-8	15287-0	PANEL, BACK AND SIDE
2	15233-1	32069-2	FALSE TOP, REAR
3A	15238-2	32075-7	FLUE, LEFT SIDE
3B	15239-0	32076-5	FLUE, RIGHT SIDE
4	15232-3	15232-3	FALSE TOP, FRONT
5	15609-4	31642-3	DOOR ASSEMBLY
6	3173-9	3173-9	HANDLE
7	15187-4	15305-2	GUARD RAIL ASSEMBLY
8	27394-5	27394-5	VALVE PANEL BRACKET
9	CALL	CALL	MANIFOLD- FFV
10	42687-1	42687-1	FRAME BURNER ASSEMBLY
11	26700-7	26700-7	BURNER w/ SET SCREW
12	11614-9	11614-9	CERAMIC INSULATOR
13	11611-4	11611-4	CERAMIC, LARGE
13A	28387-8	28387-8	CERAMIC KIT (10 ea. 11611-4 Large Ceramics; 4 ea. 11614-9 Ceramic Insulators)
14	15359-1	15359-1	HEAT SHIELD
15	15223-4	31645-8	OVEN BOTTOM LINER
16	1604-7	1579-2	WIRE RACK
17	15182-3	15295-1	FIRE BOX FRONT ASSEMBLY
18A	41741-6	41741-6	PILOT ASSEMBLY W/ SHIELD
18B	26180-7	26180-7	PILOT INJECTOR - NATURAL GAS
18C	26181-5	26181-5	PILOT INJECTOR - PROPANE GAS
18D	26177-7	26177-7	THERMOCOUPLE - M9X1 X1500MM
19	3397-9	26177-7	ORIFICE BRACKET ASSEMBLY
20	1280-7	1280-7	UNION, TUBING
21	1252-1	1252-1	TUBING STEEL - 7/16" OD X 508MM
22	6378-9	6378-9	HEX COMP. FITTING ASSEMBLY
23A	6150-6	6150-6	ORIFICE - NATURAL GAS
23B	6381-9	6381-9	ORIFICE - PROPANE GAS
24	20923-6	20923-6	GASKET, VENTURI

ITEM	PART NUMBERS		DESCRIPTION
	E36W36	E43W36	
25	20924-4	20924-4	VENTURI, AIR MIXER ASSY
26	1231-9	1231-9	TUBING, ALUMINUM
27A	1601-2	1601-2	GRID, WIRE-LEFT; CHROME (PORCELAIN AVAILABLE)
27B	N/A	1602-0	GRID, WIRE-CENTER; CHROME (PORCELAIN AVAILABLE)
27C	1601-2	1601-2	GRID, WIRE-RIGHT; CHROME (PORCELAIN AVAILABLE)
28	3396-0	3396-0	BEARING ASSEMBLY
29	32376-4	38040-7	GRID FRAME ASSEMBLY/BEARING
30	15240-4	15328-1	DRIP DEFLECTOR
31	4660-4	4661-2	CARRIAGE ASSEMBLY
32	2033-8	2033-8	KNOB, BLACK BALL
33	3504-1	3504-1	SLEEVE
34	3506-8	3506-8	THREADED ROD
35	3503-3	3503-3	TUBE AND GEAR ASSEMBLY
36	23753-1	23753-1	SPRING, HANDLE
37	14442-8	14442-8	HANDLE ASSEMBLY BRACKET
38	15244-7	15244-7	BRACKET, CARRIAGE SPRING
39	1938-0	1938-0	EYE BOLT
40	34258-0	2034-6	CARRIAGE SPRING
41	3507-6	3507-6	GEAR, w/ ANGLE BRACKET
42	28365-7	28365-7	CARRIAGE BOLT
43	13108-3	13109-1	STABILIZER UNIT ASSEMBLY
45	40415-2	40415-2	FLAME FAILURE VALVE ASSY
45	43475-2	43475-2	FLAME FAILURE VALVE (NO FITTINGS)
46	CALL	CALL	PANEL, VALVE CONTROL
47	43476-0	43476-0	VALVE HANDLE W/O RING
48A	14605-6	14605-6	REGULATOR, GAS PRESSURE - NATURAL GAS
48B	1040-5	1040-5	REGULATOR, GAS PRESSURE - PROPANE GAS
49	4291-9	4291-9	GREASE DRAWER, 14" x 26 1/2" x 4"

Montague E136 Series Heavy Duty Range Parts List

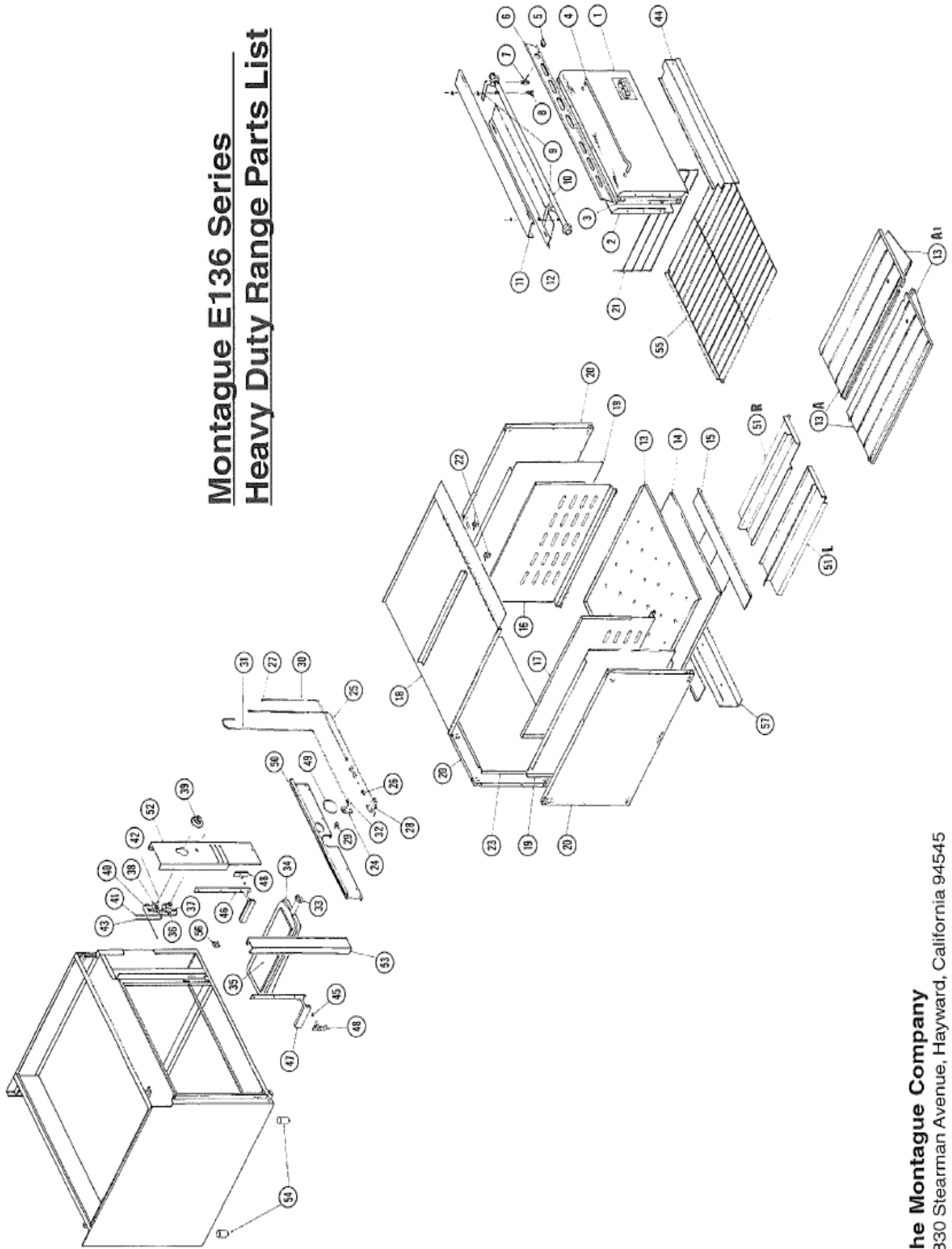

The Montague Company
1830 Stearman Avenue, Hayward, California 94545

<u>Item</u>	<u>Part #</u>	<u>Description</u>
1	8955-9	Door Panel, Ext. - ptd (w/ nameplate)
1	7644-9	Door Panel, Ext. - S/S (w/ nameplate)
1	6134-4	Door Panel, Ext. - ptd (w/ embossed "M")
1	6135-2	Door Panel, Ext. - S/S (w/ embossed "M")
2	1548-2	Door Panel, Int., (prior 8/84)
2	2428-7	Door Panel, Int., (post 8/84)
3	1424-9	Insulation, Door
4	3173-9	Handle, Door
5	2004-4	Handle, Main Oven Valve
6	3566-1	Valve Panel - 36" S/S (specify width)
6	4576-4	Valve Panel - 34" S/S (frytop models only)
7	1056-1	Valve, Oven - 1/4" NPTM x 7/16" cc (new style)
7	4490-3	Valve, Oven - 9/16"-27 x 7/16" cc (old style)
8	1288-2	Pilot Fitting - 1/8" NPT x 1/4" tube
9	6137-9	Bracket, Valve Panel
10	1073-1	Manifold - 36", Comb. (order by length & model)
11	6860-8	Guard Rail - 36", S/S (post 1/85- consult factory)
12	4285-4	Manifold Drip Shield (specify length)
13	1547-4	Oven Bottom - Porcelain (change #17)
13	9051-4	Oven Bottom - Porcelain (change #18)
13A	4387-7	Oven Bottom- Cast Iron (sold as pair)
13A1	7987-4	Heat Deflector for 13A bottom
14	4601-9	Heat Deflector
15	6593-5	Burner Baffle, S/S
16	9044-1	Side Liner, Oven - Right (change #18)
17	9043-3	Side Liner, Oven - Left (change #18)
18	1538-5	Top Liner, Oven - Porcelain
19	12874-0	Interior Liner - Left & Right (with stiffener)
20	12894-5	Insulation, Oven - Left, Right & Rear
21	7223-0	Rack Guide - Left or Right
22	1942-9	Clip, Thermostat Bulb
23	1536-9	Rear Liner, Oven - Porcelain
24	6149-2	Bracket, Orifice Fitting - Oven
25	1013-8	Thermocouple Please Order by # and Des.
26	2190-3	Orifice, Oven Pilot (Nat. Gas)
26	2191-1	Orifice, Oven Pilot (LP Gas)
27	6155-7	Compression Nut & Ferrel - 1/4" tube
28	1017-0	Pilot Burner (Nat. Gas)
28	1018-9	Pilot Burner (LP Gas)
29	6150-6	Orifice, Main Burner (Nat. Gas)
29	6151-4	Orifice, Main Burner (LP Gas)
30	3604-8	Tubing - 1/4" (safety valve to pilot burner)
31	3602-1	Tubing - 7/16" (thermostat to burner - 42")
32	2412-0	Elbow Assembly w/ Orifice (Nat. Gas)
32	1015-4	Elbow Assembly w/ Orifice (LP Gas)
33	2037-0	Air Mixer, Oven Burner
34	6350-9	Burner, Oven (new style less pilot mount)
35	9518-4	Baffle, Main Oven Burner
36	34604-7	Safety Valve, Pilot
37	1277-7	Fitting - 1/4" tube (tapered, compression)
38	1061-8	Thermostat, FDTO (with dial 500)
39	1977-1	Dial, FDTO Thermostat
40	1287-4	Fitting 3/8" NPT x 7/16" tube
41	3600-5	Tubing 7/16" (main valve to safety - change #8)
42	1150-9	Nipple, Pipe - 3/8" x 2"
43	3605-5	Tubing 1/4" (manifold to safety valve)
44	3459-2	Panel, Firebox - Ptd (change #14- clip style)
44	3524-6	Panel, Firebox - S/S (change #14- clip style)
45	1260-2	Spacer, Door Pin
46	6077-1	Door Trunnion- Right
47	6979-8	Door Trunnion- Left
48	3393-6	Pin, Oven Door
49	4274-9	Door, Pilot Access
50	4275-7	Burner Compartment Front
51L	6346-0	Baffle, Air - Left
51R	6348-7	Baffle, Air - Right
52	4645-0	Panel, Right Front Control - Ptd (after 9/70)
52	4610-8	Panel, Right Front Control - S/S (after 9/70)
53	4288-9	Panel, Left Front Control - Ptd (after 9/70)
53	4286-2	Panel, Left Front Control - S/S (after 9/70)
54	3468-1	Leg - 6" Ptd
54	3467-3	Leg - 6" S/S
55	9005-0	Rack , Oven - 25 5/8" x 26"
56	6926-4	Catch, Spring (female)
57	7584-1	Support, Channel

WARNING! If not installed, operated, and maintained in accordance with the manufacturer's instructions, this product could expose you to substances in fuel or in fuel combustion which can cause death or serious illness and which are known to the State of California to cause cancer, birth defects, or other reproductive harm.

WARNING! All personnel in the work place who may be subject to any exposure of carbon monoxide must be warned of such possible exposure. This warning should be conveyed in a manner so that it is clearly understood by the employee, and the employee should be asked if in fact he or she understands the correct method of operation of the equipment and that a risk of exposure exists if the equipment is operated improperly.

**SAVE THESE INSTRUCTIONS FOR
FUTURE USE.**



The Montague Company
1830 Stearman Avenue
P.O. Box 4954
Hayward, CA 94540-4954
WWW.MONTAGUECOMPANY.COM

P/N 47318-9RC