

INSTRUCTION MANUAL

INSTALLATION / OPERATION / SERVICE & PARTS



**MODELS:
T SERIES**

These instructions should be read thoroughly before attempting installation.
Set up and installation should be performed by qualified installation personnel.

Keep area around appliances free and clear from combustibles.

**PLEASE RETAIN THIS MANUAL
FOR FUTURE REFERENCE.**



THE MONTAGUE COMPANY
1830 STEARMAN AVENUE, P.O. BOX 4954
HAYWARD, CA. 94540-4954
TEL: 510/785-8822 FAX: 510/785-3342

IMPORTANT FOR YOUR SAFETY

THIS MANUAL HAS BEEN PREPARED FOR PERSONNEL QUALIFIED TO INSTALL GAS EQUIPMENT, WHO SHOULD PERFORM THE INITIAL FIELD START-UP AND ADJUSTMENTS OF THE EQUIPMENT COVERED BY THIS MANUAL.

POST IN A PROMINENT LOCATION THE INSTRUCTIONS TO BE FOLLOWED IN THE EVENT THE SMELL OF GAS IS DETECTED. THIS INFORMATION CAN BE OBTAINED FROM THE LOCAL GAS SUPPLIER.

WARNING

IN THE EVENT A GAS ODOR IS DETECTED, SHUT DOWN UNITS AT MAIN SHUTOFF VALVE AND CONTACT THE LOCAL GAS COMPANY OR GAS SUPPLIER FOR SERVICE.

FOR YOUR SAFETY

DO NOT STORE OR USE GASOLINE OR OTHER FLAMMABLE VAPORS OR LIQUIDS IN THE VICINITY OF THIS OR ANY OTHER APPLIANCE.

WARNING

IMPROPER INSTALLATION, ADJUSTMENT, ALTERATION, SERVICE OR MAINTENANCE CAN CAUSE PROPERTY DAMAGE, INJURY, OR DEATH.

READ THIS INSTRUCTION MANUAL THOROUGHLY BEFORE OPERATING, MAINTAINING, INSTALLING, OR SERVICING THIS EQUIPMENT.

SAVE THESE INSTRUCTIONS FOR FUTURE USE.

TABLE OF CONTENTS

Important (Shipping damage Claim Procedures)...	Page 1
Installation	Page 2 - 10
Operation	Page 11-16
Maintenance	Page 17-20
Maintenance Schedule	Page 21
Service	Page 22-30
VT26 & VT60 Wiring Diagram	Page 31
T &VT 26 Open Top Exploded View	Page 32
T & VT 60 Open Top Exploded View	Page 33
T26 Oven Exploded View	Page 34
T60 Oven Exploded View	Page 35
VT 26 Oven Exploded View	Page 36
Frytop (Manual Control) Exploded View	Page 37
Frytop (Thermostat Control) Exploded View	Page 38

IMPORTANT

SHIPPING DAMAGE CLAIM PROCEDURE:

For your protection, please note that equipment in this shipment was carefully inspected and packed by skilled personnel before leaving the factory. The transportation company assumed full responsibility for safe delivery upon acceptance of this shipment.

IF SHIPMENT ARRIVES DAMAGED:

VISIBLE LOSS OR DAMAGE - Be certain this is noted on freight bill or express receipt, and signed by person making delivery.

FILE CLAIM FOR DAMAGES IMMEDIATELY - Regardless of the extent of damage.

CONCEALED LOSS OR DAMAGE - If damage is unnoticed until merchandise is unpacked, notify transportation company or carrier immediately, and file "concealed damage" claim with them. This should be done within fifteen (15) days of date that delivery was made to you. Be sure to retain container for inspection.

We cannot assume responsibility for damage incurred in transit. We will, however, be glad to furnish you with necessary documents to support your claim.

INSTALLATION

The Montague Technostar gas ranges are manufactured for use with the type of gas indicated on the nameplate.

The Montague Technostar gas convection oven type ranges are produced with the best possible material and workmanship. **PROPER INSTALLATION IS ESSENTIAL FOR SAFE AND EFFICIENT TROUBLE-FREE OPERATION.**

THE INSTALLATION INSTRUCTIONS CONTAINED HEREIN ARE FOR THE USE OF QUALIFIED INSTALLATION AND SERVICE PERSONNEL ONLY. INSTALLATION OR SERVICE BY OTHER THAN QUALIFIED PERSONNEL MAY RESULT IN DAMAGE TO THE OVEN AND/OR INJURY TO THE OPERATOR.

Qualified installation personnel are individuals, a firm, corporation or company which either in person, or through a representative are engaged in, and are responsible for:

A. The installation or replacement of gas piping or the connection, installation, repair or servicing of equipment, who is experienced in such work, familiar with all precautions required, and has complied with all requirements of state or local authorities having jurisdiction. Reference: National Fuel Gas Code Z223.1, Section 1.4.

B. The installation of electrical wiring from the electric meter, main control box or service outlet to the electric appliance. Qualified installation personnel must be experienced in such work, be familiar with all precautions required and have complied with all requirements of state and local authorities having jurisdiction. Reference: National Electric Code, NFPA No. 70.

READ CAREFULLY AND FOLLOW THESE INSTRUCTIONS

THE RANGE(S) MUST BE INSTALLED IN ACCORDANCE WITH LOCAL CODES, OR IN THE ABSENCE OF LOCAL CODES, WITH THE NATIONAL FUEL GAS CODE, ANSI Z223.1, NATURAL GAS INSTALLATION CODE, CAN/CGA-B149.1, OR THE PROPANE INSTALLATION CODE CAN/CGA-B149.2, AS APPLICABLE, INCLUDING:

The appliance and its individual shutoff valve must be disconnected from the gas supply piping system during any pressure testing of that system at test pressures in excess of 1/2 psig. (3.45 kPa).

The appliance must be isolated from the gas supply piping system by closing its individual manual shutoff valve during any pressure testing of the gas supply piping system at test pressure equal to or less than 1/2 psig. (3.45 kPa).

INSTALLATION

THE UNIT, WHEN INSTALLED, MUST BE ELECTRICALLY GROUNDED IN ACCORDANCE WITH LOCAL CODES, OR IN ABSENCE OF LOCAL CODES, WITH THE NATIONAL ELECTRICAL CODE, ANSI/NFPA 70, OR THE CANADIAN ELECTRICAL CODE, CSA C22.2, AS APPLICABLE.

PROVISIONS MUST BE MADE FOR ADEQUATE AIR SUPPLY TO THE UNIT.

VENTILATING HOOD

The range(s) must be installed under a properly designed hood. The hood should extend at least 6" beyond all sides of the unit. The hood should be connected to an adequate mechanical exhaust system.

Information on the construction and installation of ventilating hoods may be obtained from the "Standard for the Installation of Equipment for the Removal of Smoke and Grease Laden Vapors from Commercial Cooking Equipment", NFPA 96, available from the National Fire Protection Association. Batterymarch Park, Quincy, Ma 02269.

It is also necessary that sufficient room air ingress be allowed to compensate for the amount of air removed by the ventilating system. Otherwise, a subnormal atmospheric pressure will occur which may interfere with burner performance or may extinguish the pilot flame. In case of unsatisfactory range performance, check with the exhaust fan in the "OFF" position.

CLEARANCES

Adequate clearance must be provided at the side, back and in the aisle to allow the doors to open sufficiently to permit the removal of the racks and for serviceability. Adequate clearance for air openings into the combustion chamber must be provided.

	Combustible Construction	Non-Combustible Construction
BACK: (Standard)	2" (5.08)	No clearance necessary
BACK: (For VT)	5" (12.7 cm)	5" (12.7 cm)
LT & RT SIDE:	11" (27.9 cm)	2" (5.1 cm)

**6" (15.2 cm) HIGH LEGS: SUITABLE FOR INSTALLATION ON COMBUSTIBLE FLOORS.
WITHOUT LEGS: FOR USE ONLY ON NON-COMBUSTIBLE FLOORS.**

CAUTION

**DO NOT OBSTRUCT THE FLOW OF COMBUSTION AND VENTILATION AIR.
KEEP APPLIANCE AREA FREE AND CLEAR FROM COMBUSTIBLES.**

INSTALLATION

DO NOT LIFT RANGE BY THE FRONT RAIL.

IF RANGE IS EQUIPPED WITH A FRYTOP SECTION, REMOVE WOOD SHIPPING STRIPS LOCATED BELOW THE GREASE TROUGH. PROTECTIVE COATING CAN BE REMOVED BY APPLYING A PRODUCT CALLED "GOO GONE" OR CONCENTRATED PINE SOL. RINSE AND DRY THOROUGHLY BEFORE SEASONING GRIDDLE.

ASSEMBLY

Uncrate range as near to final location as possible. Remove all shipping wire from burners and all packing material and accessories from oven interior.

Then assemble as follows:

Floor Mounted Range:

1. Screw the adjustable feet of the legs in all the way. Then tightly screw the complete leg assembly into mounting holes at each corner of the range. If the unit is intended for curb installation, no legs are provided. The curb must be non-combustible material.
2. Install door handle by placing threaded ends of handle through pre-punched holes on exterior door panel (see diagram for correct orientation). Secure handle with screws that are mounted through pre-punched holes of interior liner.
3. Lift high shelf above the range and slide channels into position. Secure to range back with screws that are provided.

INSTALLATION

Counter Ranges:

Set unit in desired position and secure to counter using holes provided at rear and bracket at front.

All Ranges:

1. Make sure burner grates are aligned in proper orientation as seen below.



2. Install top burner valve handles and thermostat knob(s). If top burner valve handles fit loose on valve shaft, spread slot on end of shaft slightly with screwdriver blade so that handle will fit snug.
3. When range is in permanent position, level unit by placing carpenter's level on oven bottom and level from front to back and side to side.

ADJUST AS FOLLOWS:

FLOOR & COUNTER INSTALLATION ON LEGS: The foot of the leg should be adjusted all the way in before attempting to level the unit. To increase the height of the leg, rotate the adjustable foot clockwise until desired height is achieved. Repeat this procedure with all legs. Use a level to ensure that all legs have been adjusted correctly

CURB INSTALLATION: Level range from front to rear and side to side using a carpenter's level. Place shim under low side.

INSTALLATION

FRY TOP RANGES:

Leveling bolts are at the rear of the range under the Fry Top plate. Adjust leveling bolts so that the plate is pitched to the front to provide for grease runoff and proper ventilation. The heat from the plate should rise to the rear of the unit to prevent damage to valves and other components. Be sure wooden strips have been removed from below grease trough.

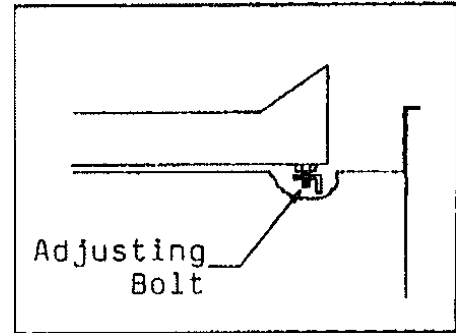

GAS PRESSURE REGULATOR

**THIS RANGE IS DESIGNED FOR USE WITH A GAS PRESSURE REGULATOR.
THE REGULATOR SUPPLIED WITH THIS UNIT MUST BE USED.**

FOR NATURAL GAS: This gas pressure regulator is factory adjusted for 6.0" W.C. manifold pressure. The rated inlet pressure to the regulator should not exceed 1/2psi.

FOR PROPANE GAS: This gas pressure regulator is factory adjusted for 10.0" W.C. manifold pressure. The rated inlet pressure to the regulator should not exceed 1/2psi.

Unless otherwise specified, the range is equipped with fixed orifices for use with a manifold pressure of 6.0" water column for natural gas and 10.0" water column for propane gas.

GAS CONNECTION:

Before connecting the range to the gas supply line, be sure that all new piping has been cleaned and purged to prevent any foreign matter from being carried into the controls by the gas. In some cases, filters or drops are recommended. A separate Gas Shut Off Valve must be installed upstream from the gas pressure regulator adjacent to the range and be located in an accessible area.

It is important that adequately sized piping be run directly to the point of connection at the range, with as few elbows and tees as possible. Consult local gas company for proper piping size and gas pressure.

INSTALLATION

PIPE JOINT COMPOUND OR THREAD SEALANT THAT IS USED SHOULD BE RESISTANT TO ACTION OF LIQUIFIED PETROLEUM GASES.

Install the gas pressure regulator with gas flowing as indicated by the arrow on the regulator. Use pipe compound or thread sealant and carefully thread regulator to pipe so that there is no cross threading, etc., which could cause leakage.

Apply wrench only to the flat areas around the pipe tapping at the end being threaded to the pipe to avoid possible damage to the regulator body which could result in leakage.

Connect the gas supply line from the Service Gas Shut Off valve to the inlet side of the gas pressure regulator using 3/4" pipe. If flexible or semi-flexible connectors are used, an AGA listed flexible connector with a minimum I.D. equal to 3/4" pipe must be used. Line sizing should be based on the BTU rating or requirement of the unit installed. **DO NOT USE A DOMESTIC APPLIANCE TYPE GAS FLEXIBLE CONNECTOR.** Avoid kinks or sharp bends that could restrict gas flow.

Turn Gas Shut Off Valve "ON" and immediately check carefully for gas leaks. Do this before attempting to operate the range.

TEST ALL PIPE JOINTS FOR LEAKS BEFORE OPERATING RANGE. THIS INCLUDES ALL GAS CONNECTIONS THAT MAY HAVE LOOSENED DURING SHIPMENT. USE A RICH SOAP SOLUTION (OR OTHER ACCEPTED LEAK TESTER) AROUND ALL PIPE CONNECTIONS AND ALL OTHER JOINTS. DO NOT USE AN OPEN FLAME. ABSOLUTELY NO LEAKAGE SHOULD OCCUR, OTHERWISE THERE IS A DANGER OF FIRE OR EXPLOSION DEPENDING UPON CONDITIONS. NEVER USE IF LEAKAGE IS DETECTED.

INSTALLATION

BURNER ADJUSTMENT:

The efficiency of the range depends on a delicate balance between the supply of air and the volume of gas so that complete combustion is achieved. Whenever this balance is disturbed, poor operating characteristics occur.

The air supply is controlled by an air shutter on the front of the burner. The air shutter openings should be increased until the flame on the burner begins to “lift”. The air shutter should then be closed slightly and locked in place. A yellow streaming flame indicates insufficient air. This condition can be corrected by increasing the air shutter opening

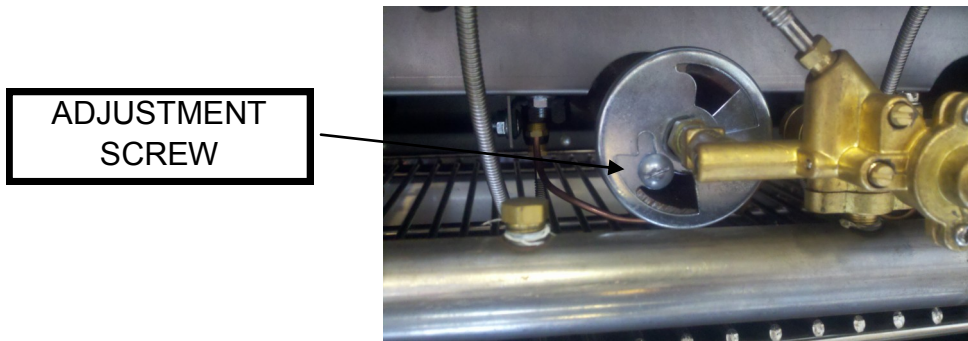

FRY TOP AND OVEN THERMOSTATS:

The by-pass (minimum burner flame) has been adjusted at the factory and should require no further adjustment.



MODELS T26 & VT 26 GRIDDLES
MODELS T60 & VT 60 GRIDDLES

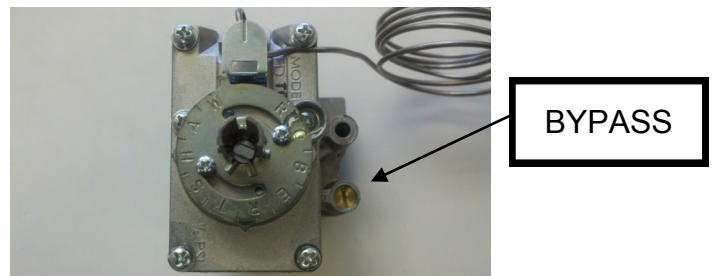

MODELS T26 & VT 26 OVEN

THE BY-PASS FLAME MUST BE RECHECKED WHEN PERFORMING CHECKOUT OF RANGE PRIOR TO PLACING EQUIPMENT INSERVICE. THE BY-PASS MUST BE SET CAREFULLY AND ACCURATELY. REFER TO SERVICE SECTION OF THIS MANUAL FOR PROPER PROCEDURE.

INSTALLATION

MODELS VT26 & VT60

ELECTRICAL CONCECTION

Unless otherwise specified, the range is equipped with a 6 feet flexible supply cord for 115 VAC, 60 or 50 Hertz, single phase units. The wiring diagram is located on the back of the range.

NOTE: this appliance when installed, must be electrically grounded in accordance with local codes, or in the absence of local codes, with the national electrical code, ANSI/NFPA No. 70-1984.

115 VAC - 60 Hz - SINGLE PHASE

Ranges with this electrical rating are factory supplied with a three wire cord and three prong plug which fits any standard three prong grounded receptacle. A separate 15 amp supply is needed for each oven.

ELECTRICAL GROUNDING INSTRUCTIONS



WARNING

THIS APPLIANCE IS EQUIPPED WITH A THREE PRONG (GROUNDING) PLUG FOR YOUR PROTECTION AGAINST SHOCK HAZARD AND SHOULD BE PLUGGED DIRECTLY INTO A PROPERLY GROUNDED THREE-PRONG RECEPTACLE. DO NOT CUT OR REMOVE THE GROUNDING PRONG FROM THIS PLUG.

208-240 VAC - 60 Hz - SINGLE PHASE (2 WIRE)

Ranges with this electrical rating are factory equipped with a terminal block. To connect supply wires, remove cover from connection box at right rear of range. Route supply wires and ground wire through hole with strain relief fitting at top of connection box. Attach supply wires to proper terminal of terminal block. Attach ground wire to ground lug inside connection box. See wiring diagram for proper connection.

220 VAC - 50 Hz - SINGLE PHASE (2 WIRE)

Follow steps outlined above. Refer to wiring diagram for proper connection.

OPERATION

OPERATING INFORMATION FOR THE RANGE HAS BEEN PREPARED FOR USE BY QUALIFIED AND/OR PROFESSIONAL OPERATING PERSONNEL

CAUTION

DO NOT OBSTRUCT THE FLOW OF COMBUSTION AND VENTILATION AIR. KEEP THE APPLIANCE AREA FREE AND CLEAR FROM COMBUSTIBLES

IN THE EVENT A GAS ODOR IS DETECTED, SHUT DOWN UNITS AT MAIN SHUT OFF VALVE AND CONTACT THE LOCAL GAS COMPANY OR GAS SUPPLIER FOR SERVICE.

GAS CONTROLS (STANDARD MANUAL VALVE):

TOP BURNERS - Open Top, Hot Top, and Manual Fry Top

Check that pilots are burning. Then rotate valve handles counterclockwise to full on, burner will ignite automatically. Adjust flame height as desired. To shut down, rotate valve handle clockwise to the "OFF" position.

GAS CONTROLS (FLAME FAILURE VALVE):

TOP BURNERS - Open Top, Hot Top, Fry Top

1. Push in the tap and turn it counter-clockwise to the ignition "★" position
2. Holding the tap in fully in, light the pilot with a match or extended lighter.
3. When the pilot is lit, continue to hold the tap fully in for 20 seconds, then release it. If the pilot goes out, wait for (5) minutes, then repeat from step 1.
4. When the pilot is established, push the tap in again and turn it counter-clockwise to the full flame position "▲", thus lighting the main burner.
5. For low flame or simmer, push tap in and turn it counter-clockwise to the lowest position.
6. To shut burner off, turn the dial to the "●" position and the safety device will disengage within 60 seconds

OPERATION

GAS CONTROLS (THERMOSTAT CONTROLLED)

TOP BURNERS - Fry Top

1. Light Pilot with extended match or lighter
2. Push t-stat dial inward and rotate counter clockwise to max setting
3. After ignition, turn dial to desired setting
4. To shut down, rotate t-stat clockwise to "OFF" position

OVEN

A.) T60 & VT60 SERIES (LIGHTING)

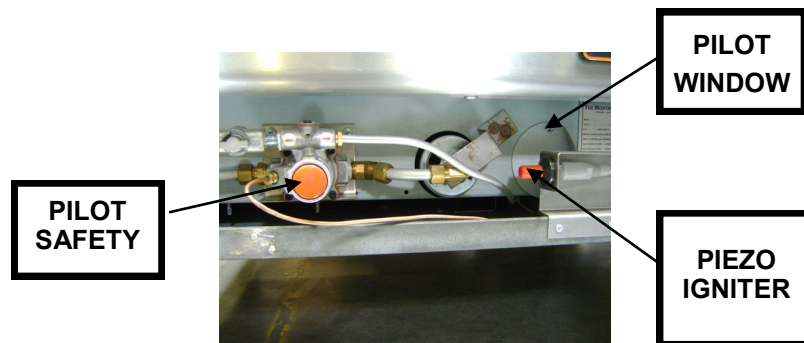

1. Turn thermostat knob to " **OFF** " position and wait five (5) minutes.
2. Remove burner compartment cover and open pilot access door.
3. Locate the Piezo Igniter in front of the pilot access door..
4. Press and hold in the red button of the Pilot Safety Valve while repeatedly depressing the button on the Piezo Igniter until the pilot burner ignites.
5. After pilot burner ignites, continue to hold Pilot Safety red button depressed for 30 to 45 seconds or until pilot holds when button is released. If pilot goes out, repeat process.
6. If the pilot burner is unable to be lit with the piezo igniter, apply a lighted match or extended lighter to the pilot burner.
7. Close pilot access door and replace burner access panel.
8. Push thermostat dial inward and rotate dial counter-clockwise to desired temperature setting.
9. **IN THE EVENT OF PILOT FAILURE, ROTATE THERMOSTAT DIAL CLOCKWISE TO " OFF " POSITION AND WAIT 5 MINUTES FOR UNBURNED GAS TO ESCAPE FROM RANGE.**

OPERATION

OVEN

B.) V26 & VT26 SERIES (LIGHTING)

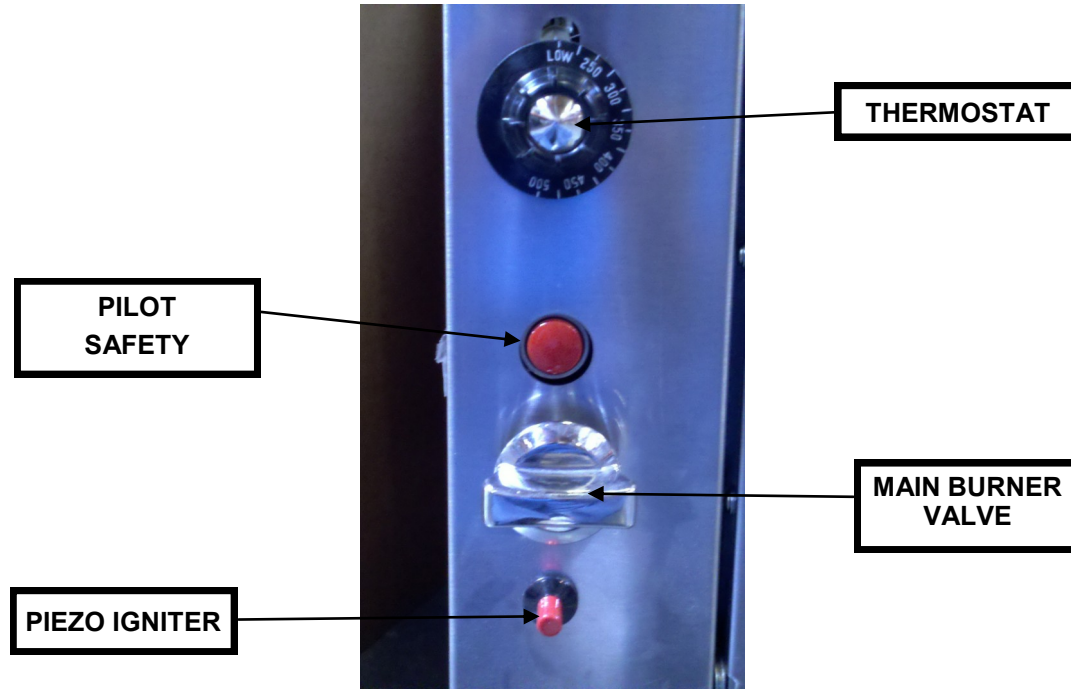

1. Turn Main Burner Valve to “ **OFF** “ position.
2. Remove burner compartment cover and open pilot access door.
3. Locate Piezo Igniter , mounted under the Main Burner Valve on the oven Control Panel.
4. Press and hold in the red button of the Pilot Safety Valve while repeatedly depressing the button on the Piezo Igniter until the pilot burner ignites. If pilot does not light wait 5 mins. Repeat previous steps 1 and 2
5. After pilot burner ignites , continue to hold Pilot Safety red button depressed for 30 to 45 seconds or until pilot holds when button is released. If pilot goes out, repeat process.
6. If the pilot burner is unable to be lit with the Piezo Igniter, apply a lighted match or extended lighter to the pilot burner
7. Close pilot access door and replace burner access panel.
8. Set desired temperature on thermostat then turn Main Burner Valve fully open to the “ **ON** “ position.
9. **IN THE EVENT OF PILOT FAILURE, ROTATE MAIN BURNER VALVE CLOCKWISE TO THE “ OFF “ POSITION AND WAIT (5) MINUTES FOR UNBURNED GAS TO ESCAPE FROM RANGE.**

OPERATION

C.) SHUT DOWN

Rotate thermostat dial clockwise to “ **OFF** “ position. (T60 &VT60)

Rotate Main Burner Valve clockwise to the “ **OFF** “ position. (T26 & VT26)

OVEN OPERATION

1. Turn thermostat dial to desired temperature.
2. Limit pre-heat time to 10-20 minutes.
3. Place food in oven. Make sure pans do not touch each other, or the oven walls.
4. Do not cover racks with aluminum foil.
5. Load and unload quickly. Avoid frequent opening of doors.
6. Turn off when not in use.

SUGGESTIONS

- There is not need to preheat an Open Top burner. Use full flame to start foods cooking quickly; reduce the flame to simmer foods. Regulate the burner so that flame tips just touch the bottom of the utensil. Use lids on pots to keep heat in. Turn burner off when not in use.
- Preheat Fry Top 10-15 minutes prior to use. Usually, medium to low flame is adequate for light frying. If Fry Top has a thermostat, use it to avoid wasting gas and for best results. During slack periods, turn the burner down.

OPERATION

VT26 & VT60

Using a Convection Oven

The convection oven offers many features and advantages not available in a conventional oven. Operation is not difficult to understand or control.

The Montague convection oven is a “Muffled” style oven that keeps the by-product of combustion separated from the air circulated in the oven. The heat surrounding the oven cavity is transferred from the outer surface into the interior of the oven. A fan continuously circulates the heated air around the product. The moving air strips away the insulating layer of moisture on the products allowing heat to penetrate faster and for more efficient baking and roasting.

Due to the differences in cooking methods, procedures and techniques for convection oven cooking may require modification for successful results. A general rule to remember is that standard recipe cooking times will be shorter and temperatures should be 25-75 degrees F lower in a convection oven.

NOTE: For convection oven cooking, reduce temperature 25-75 degrees F from those given in standard conventional oven recipes.

The following controls are used for operation of the oven.

1. Fan Switch
 - a. Fan (Top Position): Circulates air in oven.
 - b. Off (Center Position): Turns fan off.
 - c. Cool Down (Bottom Position): Provides continuous fan operation for cooling oven at the End of the work period, operates with doors opened or closed. Cools with doors open.
2. Thermostat: Sets temperature between 200-500°F (93-260°C).
3. Pilot Safety Valve: Ignites pilot and shuts down gas supply to pilot and burner in the event of pilot outage.
4. Main Burner Valve: Shuts off main burner.
5. Piezo Igniter: Provides spark to ignite pilot.

OPERATION

LIGHTING VT26 & VT60

1. Turn oven burner valve clockwise to “OFF” position. (VT26)
2. Open main shutoff valve in the rear of the unit to supply gas to the equipment.
3. Remove burner compartment access panel below the oven doors.
4. Press and hold the red button of the pilot safety valve while applying a flame to the pilot burner. If unit has a piezo igniter option, repeatedly depress the button on the piezo igniter until the pilot burner ignites. Hold pilot safety button depressed for 30-45 seconds or until pilot remains lit when button is released.
5. Replace burner compartment access panel.
6. Set thermostat to desired temperature.
7. Turn oven burner valve counter-clockwise to “ON” position. (VT26)
8. Turn on fan, which should be on at all times during cooking operation.

OVEN OPERATION (VT26 & VT60)

1. Turn on convection motor by pushing rocker switch to the “fan” position. In fan position, motor will shut off when door is opened. Motor should be on at all times or damage may occur. “Cool Down” position on switch will allow the motor to run with doors open. This position is used to cool the unit after use. When using the convection oven, Temperatures for recipes that are typically cooked in a conventional oven should be adjusted down by about 50 degrees.
2. Turn thermostat to desired set temperature
3. Turn main gas valve to the on position (For VT26 models)

SHUT DOWN

STAND BY

1. Turn oven thermostat to “OFF” position.
2. Turn fan control to “OFF” position.

COMPLETE

1. Turn all gas valves to “OFF” position.
2. Turn fan control to “OFF” position.
3. Turn electrical service off or disconnect electrical supply cord from wall outlet.
4. Shut down gas supply to unit by turning off Main gas valve.

MAINTENANCE



CAUTION

DISCONNECT POWER BEFORE CLEANING OR SERVICING. EACH OVEN SECTION HAS A SEPARATE ELECTRICAL SUPPLY CONNECTION.

GENERAL CLEANING

The complete range should be given a periodic cleaning. Lint and grease suspended in the air tend to collect in air passages. Therefore, all flueways, air passages and openings, burner ports, primary air openings, etc. should be periodically cleaned to prevent clogging.

Interior (Standard Porcelain Enamel Finish)

Frequent cleaning is required. Spillovers should be cleaned as soon as possible to prevent carbonization. Wait until oven is cool for complete cleaning. Usually a soap or detergent solution is strong enough to remove any grease residue. A combination of a (non-abrasive) commercial cleanser and nylon cleaning pad may be used for stubborn spillovers or stains. **Do not allow cleansers to come in contact with temperature probe.**

Exterior

PAINTED SURFACE

Allow equipment to cool before cleaning exterior surfaces. Painted surfaces should be cleaned using a mild soap and warm water solution on a sponge or soft cloth.

Powder coated, copper, and other such painted or plated finishes are not covered under warranty. These finishes are subject to wear and may begin to discolor and/or chip within a short period of time. Caution should be taken when cleaning. Using a mild soap and water solution will help to maintain the look and finish.

STAINLESS STEEL SURFACES

Stainless steel is an alloy of iron which contains chromium. In the process of manufacturing stainless steel, chromium in the alloy is used to form the hard oxide coating on the surface. If this is taken off through corrosion or wear, it will rust like regular steel. To remove dirt, grease or product residue from stainless steel, use water and a mild detergent if needed, applied with a sponge or lint-free cloth. Dry thoroughly with a lint-free cloth to remove grease and food splatter, or condensed vapors that have baked on the equipment, you can use a (non-abrasive) commercial cream cleanser or baking soda and water, applied with a damp lint-free cloth or sponge. Rub cleanser as gently as possible (with grain) in the direction of the polished lines. **Do not rub in a circular motion**, it will damage the finish. Rinse surface after cleaning with a damp lint-free cloth and clean water. Dry thoroughly with a clean lint-free cloth. Drying thoroughly will prevent water spots which are harmful to the finish.

MAINTENANCE



CAUTION

NEVER USE ABRASIVES, POWDERS, HARSH LIQUIDS, CAUSTICS, OR DYES AS THEY MAY LEAVE A FILM OR RESIDUE THAT WILL CLOG THE PORES OF THE SPECIAL COATING.

Precautions

- Strong bleaches tend to corrode many materials and should not come in contact with stainless steel sinks or utensils longer than 30 minutes. When these chemicals are used, the stainless should be rinsed thoroughly.

Tincture of iodine or iron should not remain in contact with stainless surfaces. These solutions which cause stainless to discolor, should be rinsed off immediately after contact.

Some foods, such as mustard, mayonnaise, lemon juice, vinegar, salt or dressings containing these, will attack and corrode stainless. You should never store them in stainless containers.

- Ordinary steel wool pads should be not used to clean stainless; particles may lodge in the surface and rust. Allowing the steel wool pad to rest on a stainless surface may cause a rusty appearance. For difficult cleaning jobs such as removing burned-on foods, nylon “sponges” or pads are recommended. When cleaning a highly polished, mirror finish, a nylon pad should be used to avoid scratching the finish.
- Gritty, hard abrasives will mar a stainless finish and are not recommended.
- Sharp knives or choppers usually have hard carbon steel edges and will leave their mark on stainless surfaces.

With only a little care, your stainless steel equipment and utensils will remain clean and bright for years to come. Stainless is hard, rust-resisting metal that adds beauty and luster to countless household products.

Helpful Hints

- To remove streaks, rub stainless steel surface with olive oil.
- To clean and polish, simply moisten a lint-free cloth with undiluted white or cider vinegar and wipe clean. Vinegar can also be used to remove heat stains.
- Oil from fingerprints can etch or tarnish stainless steel, especially mirror-polished finishes. Wherever stainless steel is visible, use a glass cleaner to remove fingerprints at the end of the day, before the finish is permanently damaged.

MAINTENANCE

Open Top Section

DAILY

Wash with warm water and mild detergent. Dry thoroughly before applying a very light coat of food grade oil to prevent rusting.

WEEKLY

Open Top Section should be washed in a solution of washing soda and water (after they are entirely cooled) Remove and wash drip pan under burners. Brush burner head weekly with a stiff wire brush and clean clogged ports with stiff wire or ice pick. Excessive grease build up may be removed from burners by soaking in a solution of washing soda. Dry burners by inverting on oven rack in a low temperature oven.

Hot Top Section

DAILY

Use scraper or griddle stone to clean excessive baked on debris wash with warm water and mild detergent dry thoroughly. Apply light coating of food grade oil. Lift rings and plates to clean all flanges and under lid. **Never pour water on a hot top section.**

Fry Top Section

- After each use, scrape griddle clean with a griddle scraper when cooked food is removed to keep surface free of encrusted material and to prevent flavor transfer.
- After each day, while griddle is warm, clean surface with a griddle stone using a back and forth motion. For stainless steel, rub in the direction of the grain to not damage the surface. Clean grease trough thoroughly and empty grease container.
- Weekly, allow griddle to cool completely and clean plate with a foodservice grade degreaser. Re-season griddle as needed, or apply a coating of cooking oil to prevent rust.
- A mixture of lemon juice and carbonated (soda) water can also be used while the griddle is warm. After applying mixture, rub griddle stone back and forth to clean surface. Dry thoroughly and re-season if needed, or apply a coating of cooking oil to prevent rust.

NOTE: To oil the griddle, use a hydrogenated shortening. Never use salad oils, margarine, or butter, as these shortenings cannot withstand temperatures exceeding 300 degrees F

MAINTENANCE

ELECTRIC MOTOR

The electric motor has been specially manufactured for this blower application and should give years of trouble-free service under normal conditions.

The motor is supplied with permanently lubricated sealed bearings which require no additional lubrication. High temperature grease has been used to increase bearing life and should only be replaced by an authorized service agent.

The motor is of an open drip-proof type construction, and as such, care should be taken to see that the ventilation openings remain clear.

The motor is equipped with built-in automatic thermal overload protection to prevent damage from overheating.

If problems do develop with the motor, contact your nearest authorized service agent.

NOTE: The motor should be periodically cleaned of grease debris and lint. Keep vent clean for peak performance.

NOTE: The fan blade should be periodically cleaned of debris to achieve peak performance for even heating.



CARE SHOULD BE USED WHEN WASHING DOWN EQUIPMENT TO KEEP WATER AND CLEANING SOLUTIONS OUT OF THE MOTOR OR DAMAGE WILL OCCUR.

NOTE: Lack of maintenance may result in premature failure of components.

MAINTENANCE SCHEDULE

Technostar Maintenance Schedule												
Components	Jan	Feb	Mar	Apr	May	June	July	Aug	Sept	Oct	Nov	Dec
Motor	1,2			1,2			1,2			1,2		
Thermostat						1,3						1,3
Door Switch	1,3			1,3			1,3			1,3		
Blower Wheel	1,2	1,2	1,2	1,2	1,2	1,2	1,2	1,2	1,2	1,2	1,2	1,2
Top Burner Pilots	1,2			1,2			1,2			1,2		
Oven Pilots	1,2			1,2			1,2			1,2		
Top Burner	2	2	2	2	2	2	2	2	2	2	2	2
Burner Grates*	2	2	2	2	2	2	2	2	2	2	2	2
Burner Valve	1,5			1,5			1,5			1,5		
Rocker Switches	1			1			1			1		
Safety Valve						1,2						1,2
Thermocouple						1,2						1,2
Grease Container*	2	2	2	2	2	2	2	2	2	2	2	2
Air Mixers	2	2	2	2	2	2	2	2	2	2	2	2

(1) Inspect (2) Clean (3) Adjust (4) Replace (As needed) (5) Lubricate

*NOTE: Lack of maintenance may result in pre-mature failure of components.

*NOTE: Parts marked with * should be cleaned daily.

*NOTE: Maintenance schedule may vary due to the gas heating value per country.

SERVICE

WHEN SERVICE IS NEEDED, CONTACT A LOCAL SERVICE COMPANY, DEALER, OR FACTORY TO PERFORM MECHANICAL MAINTENANCE AND REPAIRS. THESE INSTRUCTIONS ARE INTENDED FOR USE BY COMPETENT SERVICE PERSONNEL.

CAUTION

DISCONNECT POWER BEFORE DOING ANY SERVICE WORK. EACH SECTION HAS SEPARATE ELECTRICAL SUPPLY CONNECTION. TURN OFF GAS SUPPLY WHEN SERVICING GAS CONTROL SYSTEM.



PILOT SAFETY VALVE

The Baso Pilot Safety is an automatic 100% safety pilot which provides complete gas shut off in event of pilot failure. The safety valve is held closed by spring pressure. When red button is pushed by hand, gas flows to pilot. Pilot heats thermocouple creating a very small amount of electricity. This energizes a magnetic coil under the red button and holds the valve open, permitting gas to flow to main burner and pilot without holding pressure on red button. In the event of pilot failure, the flow of electricity will stop and spring will stop flow of gas to both pilot and oven burner.



PIEZO IGNITER

The PIEZO IGNITER creates an ignition spark at the pilot burner when the red button is depressed until it clicks. The spark is generated at the tip of the OVEN ELECTRODE, which is positioned inside of the pilot burner hood. The spark jumps from the OVEN ELECTRODE to the pilot burner hood, across the pilot gas exit.

SERVICE

OVEN PILOT BURNER:

Pilot Service In The Event Of Pilot Failure:

1. If pilot flame burns yellow, clean pilot orifice and pilot burner to insure a steady blue flame. The orifice can be cleaned by washing in a solvent and/or blowing out with air.
2. Flame must surround the thermocouple tip for approximately 1/2 Inch.
3. Thermocouple lead connections must be tight, clean and free of grease. The thermocouple nut should be started and turned all the way by hand. An additional quarter turn with a small wrench will then be sufficient.
4. Correct gas pressure is critical for maintaining proper pilot flame size.

CAUTION

**OVERTIGHTENING MAY CAUSE DAMAGE TO THE THERMOCOUPLE OR MAGNET AND IS UNNECESSARY SINCE THIS IS AN ELECTRIC CONNECTION.
DO NOT GRASP HEAD WITH TOOLS WHILE CHANGING COMPONENT.**

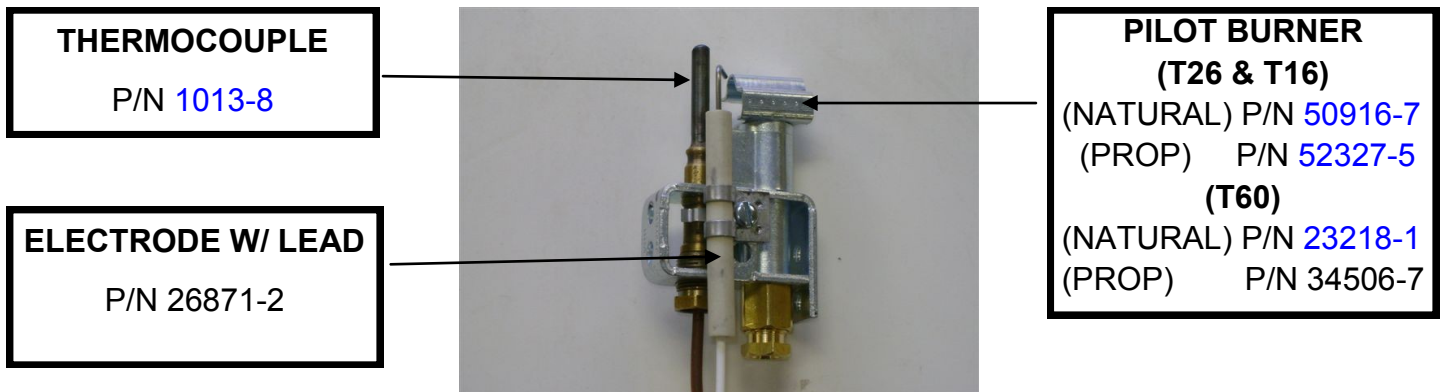

THERMOCOUPLE OUTPUT

OPEN CIRCUIT MILLIVOLT RANGE	
NORMAL	NOT LESS THAN
15-25	8

If the closed circuit check shows thermocouple output is greater than 8 millivolts and pilot will not remain lit when reset button is released, replace pilot safety valve.

SERVICE

FRYTOP THERMOSTAT: (T26 & VT26) & (T60 & VT60)

The model BJ Robertshaw is a combination thermostat and gas valve. The gas is turned on and the temperature setting made by a single rotation of the dial. This valve automatically locks itself in the "OFF" position. To use, push dial inward, rotate counter-clockwise to the desired temperature. To shut gas off, rotate clockwise to the "OFF" position.

This thermostat is a precision instrument carefully made and properly calibrated (i.e. the dial is properly set) at the factory to control temperatures accurately. It should control temperatures for the proper cooking of food without recalibration. The calibration of the thermostat should not be changed until considerable experience with cooking results have definitely proved that the thermostat is not maintaining the proper temperature.

CAUTION

THE RECALIBRATION SHOULD NOT BE MADE UNTIL THE BYPASS (MINIMUM BURNER) FLAME HAS BEEN PROPERLY ADJUSTED.

FRYTOP THERMOSTAT (INSTALLATION)

With front of the griddle plate raised, slide the thermostat bulb assembly into the support brackets attached to the underside of the Fry Top plate. Tighten the two holding screws. The excess capillary tube should be pulled forward out of the heat zone so that there is no chance of it coming in contact with the burner flame. Push the sleeving up against the bulb holder. A loose fit between the bulb holder and plate may damage the thermostat so that it will not control the temperature of the Fry Top plate accurately.

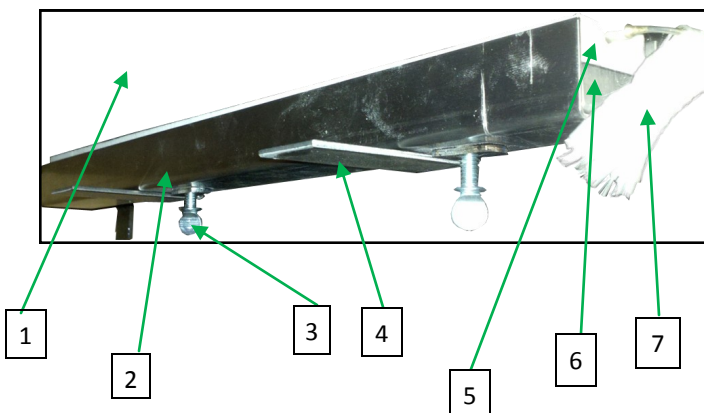

1	Fry Top Plate
2	Shield
3	Screw, Holding
4	Bracket, Support
5	Insulated Block
6	Backing Plate
7	Sleeving

SERVICE

ADJUSTMENT OF BYPASS (MINIMUM BURNER) FLAME: (T26 & VT26) & (T60 & VT60)

This is the flame which must be maintained on the burners when the Fry Top has reached the temperature set on the dial. Enough gas must be bypassed by the control to keep the entire burner lit. The thermostat regulates the flame from high to low in accordance with the Fry Top temperature and will automatically turn down to this bypass flame when the temperature set on dial is attained.

Special care should be taken to see that the thermostat bulb is in its proper place and no part of the capillary tube is in any flame or heat zone. The Fry Top plate should never be removed without first removing the thermostat bulb(s) from beneath the plate. Never allow capillary tube to be kinked or crushed.

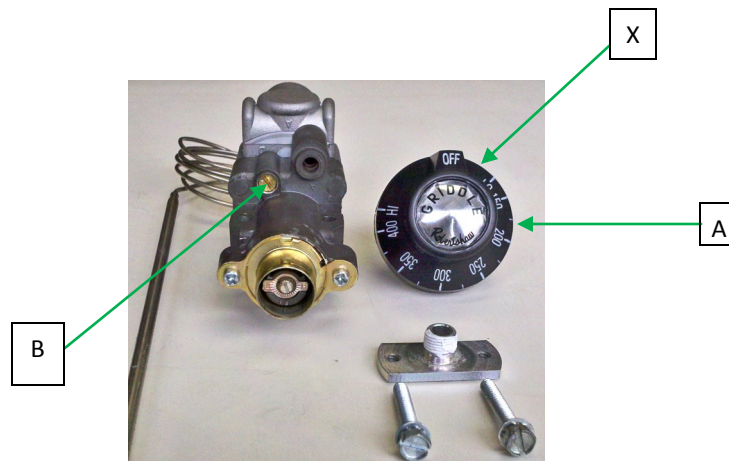

THE BYPASS MUST BE SET CAREFULLY AND ACCURATELY AS FOLLOWS:

1. Light burners and turn Dial (A) counter-clockwise and to a point midway between the "GAS ON" mark and the next graduation to the right of it (shown by "X"). If the burner goes out entirely, the bypass is closed.
2. Slip off Dial (A). Remove the valve panel from the front of the range.
3. With a screwdriver, turn bypass adjuster (B). Turning it out counter-clockwise increases the bypass flame; turning it in clockwise decreases the bypass flame. Adjust until there is a flame approximately 1/8" high over the entire burner.
4. Replace dial, rotating dial clockwise until it snaps into its original position.
5. Reinstall the valve panel on front of the range.

SERVICE

FRY TOP THERMOSTAT CALIBRATION CHECK:

The Fry Top temperature should be checked or recalibrated with the Fry Top hot. **NOTE:** See “Adjustment of Bypass (Minimum Burner) Flame” before recalibrating this thermostat.

HOT CHECK METHOD:

1. Place reliable thermometer in center of the top of the Fry Top over the thermal bulb.
2. Set dial (A) to 350 degrees F.
3. Wait until temperature rises and remains constant.
4. If dial does not agree with thermometer readings, slip off dial (A) and push out metal insert.
5. Replace dial, turn to 350 degree F mark.
6. Hold dial firmly, insert screwdriver through center of dial and push calibration stem inward.
DO NOT TURN THIS STEM.
7. While holding calibration stem in firmly with screwdriver, turn dial until it is set at the actual Fry Top temperature as it is shown by the thermometer. Release pressure on calibration stem. Replace dial insert.

OVEN THERMOSTAT: (T60 & VT60)

The T60 & VT 60 model ovens are controlled with the BJ Invensys Thermostat. This is a combination thermostat and gas valve. The gas is turned on and the temperature setting is made by a single rotation of the dial. This valve automatically locks itself in the “ **OFF** ” position. To use, push dial inward, rotate counter-clockwise to the desired temperature. To shut gas off, rotate clockwise to “ **OFF** ” position.

This thermostat is a precision instrument carefully made and properly calibrated (i.e. the dial is properly set) at the factory to control temperatures accurately. It should control temperatures for the proper cooking of food without recalibration. The calibration of this thermostat should not be changed until considerable experience with cooking results has definitely proved that the thermostat is not maintaining the proper temperature.

CAUTION

THE RECALIBRATION SHOULD NOT BE MADE UNTIL THE BYPASS (MINIMUM BURNER) FLAME HAS BEEN PROPERLY ADJUSTED.

SERVICE

ADJUSTMENT OF BYPASS (MINIMUM BURNER) FLAME:(T60 & VT60)

This is the flame that must be maintained on the burners when the oven has come up to the temperature set on the dial. Enough gas must be bypassed by the control to keep the entire burner lit. The thermostat regulates the flame from high to low in accordance with the oven temperature and will automatically turn down to this bypass flame when the temperatures set on the dial is attained in the oven.

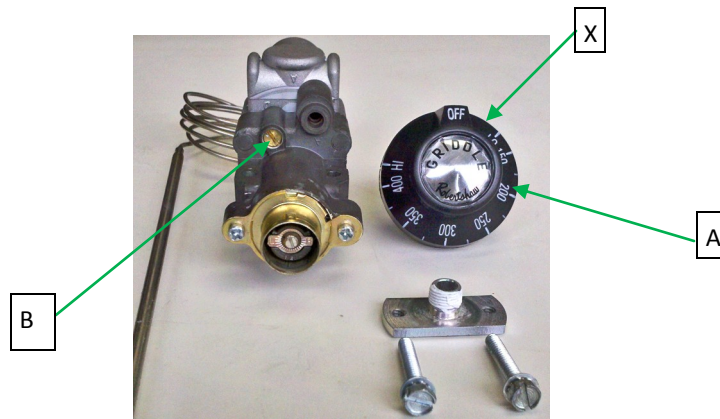

THE BYPASS MUST BE SET CAREFULLY AND ACCURATELY AS FOLLOWS :

1. Light burners and turn dial (A) counter-clockwise and to a point midway between the “ Gas On “ mark and next graduation to the right of it (shown by “ X “). If the burner goes out entirely, the bypass is closed.
2. Slip off dial (A). Remove valve panel from front of range.
3. With a screw driver, turn Bypass adjuster (B). Turning it out counter-clockwise increases the bypass flame; turning it in clockwise decreases the bypass flame. Adjust until there is a flame approximately 1/8” high over the entire burner.
4. Replace dial, rotating dial clockwise until it snaps into its original position.
5. Reinstall valve panel on front of range.

SERVICE

OVEN THERMOSTAT: (T26 & VT26)

Field recalibration is seldom necessary, and should not be resorted to unless experience with cooking results definitely proves that the control is not maintaining the temperature to which the dial is set. To check oven temperatures when recalibrating, use a calibrated Test Instrument or a reliable oven thermometer.

CAUTION:

THE RECALIBRATION SHOULD NOT BE MADE UNTIL THE BYPASS (MINIMUM BURNER) FLAME HAS BEEN PROPERLY ADJUSTED

ADJUSTMENT OF BYPASS (MINIMUM BURNER FLAME) : (T26 & VT26)

Enough gas must be bypassed through the heat control to keep the entire burner lit while in use. The control regulates the flame from high to low.

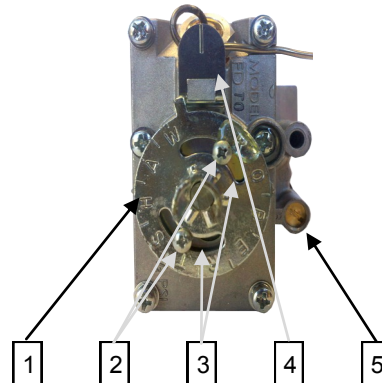

1	Calibration Plate
2	Calibration Screws
3	Screw Clearance
4	Dial Stop
5	Bypass Adjustor

PROCEDURE:

1. Turn dial to 300 degrees F.
2. Light main burner.
3. After oven temperature rises and remains constant, turn dial back to low. This closes main valve and permits only the bypass gas to the burner.
4. Remove dial.
5. With a screwdriver, turn the bypass flame adjuster screw counter-clockwise to increase the bypass flame or clockwise to decrease it until the flame over the entire burner is approximately 1/8" high. Replace dial.

SERVICE

THERMOSTAT CALIBRATION CHECK:

1. Place the thermocouple of test instrument or thermometer in the middle of the oven.
2. Light the main burner.
3. Turn the dial so that the 400 degree mark lines up with the indicator mark on the dial stop.
4. Allow the oven to heat until thermostat throttles down to bypass. After sufficient time, check temperature. If the temperature does not read within 15 degrees of dial setting, recalibrate as follows:
 - A.) Pull dial straight off without turning.
 - B.) Hold calibration plate and loosen the two calibration lock screws until the plate can be moved independently of the control.
 - C.) Turn calibration plate so that the instrument or thermometer reading is in line with the indicator mark. Hold plate and tighten screws firmly. On controls where the plate has no temperature markings, use a chart to determine the temperature degrees between letters. Turn the calibration plate counter-clockwise if the test reading is higher than the dial setting, or clockwise if the reading is lower than the dial setting.
 - D.) Replace dial.

NOTE: If the above adjustment is prevented by the two loosened calibration lock screws being in contact with the ends of the screw clearance slots in the calibration plate, remove the screws and after turning the calibration plate to the proper location, reassemble screws in the other tapped holes designed for them.

RECALIBRATION CHART		
DIAL RANGE	DEGREES BETWEEN MARKS	CALIBRATION MARK
200 TO 500	50 DEGREES	400

SERVICE

OPERATIONAL DIFFICULTIES & PROBABLE CAUSES:

Oven Pilot Goes Out:

1. Gas shut off.
2. Poor exhaust conditions in flue snuffs out flame.
3. Too much draft pulls flame away from thermocouple.
4. Pilot flame too low.
5. Thermocouple defective.
6. Thermocouple connection on safety valve loose.
7. Pilot orifice dirty.
8. Pilot safety valve defective.
9. Gas leak at pilot orifice fitting.
10. Restricted or plugged vent on gas pressure regulator.
11. Incorrect gas pressure setting on pressure regulator.
12. Make up air blowing at flue outlet.

Oven burner Fails To Come On:

1. Burner valve is off. (models T26 & VT26 only)
2. Burner orifice plugged.
3. Thermostat out of calibration.
4. Minimum flame adjustment closed and thermostat setting too low.

Oven Temperature Is Higher Than Dial Setting:

1. Oven thermostat out of calibration.
2. Minimum flame too high. (Do not lower under 1/8").
3. Broken capillary tube on thermostat.
4. Dirt under thermostat valve seat.

Temperature Is Incorrect:

1. Adjustments, see service pages 22 thru 30.

MONTAGUE TECHNOSTAR T26 OPEN TOP OPTION - EXPLODED VIEW

ITEM NO.	PART NUMBER	DESCRIPTION
1	45182-7	CASTING, GROUND
2	50244-8	BURNER ASSY
3	50242-1	BURNER ASSY
4	50795-4	MANIFOLD ASSY
5	50869-1	DEFLECTOR, DRIP
6	50875-6	GRATE SUPPORT
7	50876-4	SHEET MTL - ALZD - P/F
8	51049-1	SHEET MTL - CR - P/F
9	51050-5	SHEET MTL - ALZD - P/F
10	51051-3	CONTAINER, DRIP, W/SS TRIM
11	51055-6	PANEL, CONTROL
12	51088-2	SHEET MTL - SS - P/F
13	50689-3	HANDLE, VALVE
14	28263-4	ORIFICE, HOOD
15	02570-4	VALVE ASSY, BURNER
16	54026-9	VALVE ASSY, BURNER (PROPANE, NOT SHOWN)
17	51044-0	SUPPORT, FRONT - BURNER ASSY
18	59470-9	SUPPORT ASSY
19	52877-3	GUARD RAIL ASSY
20	52841-2	SHEET MTL - SS - P/F
21	01125-8	COUPLING, PIPE
22	01055-3	VALVE, PILOT
23	59436-9	LIGHTER, PILOT
24	59179-3	PILOT, FLASH TUBE
24	17613-3	NIPPLE, PIPE (NOT SHOWN)

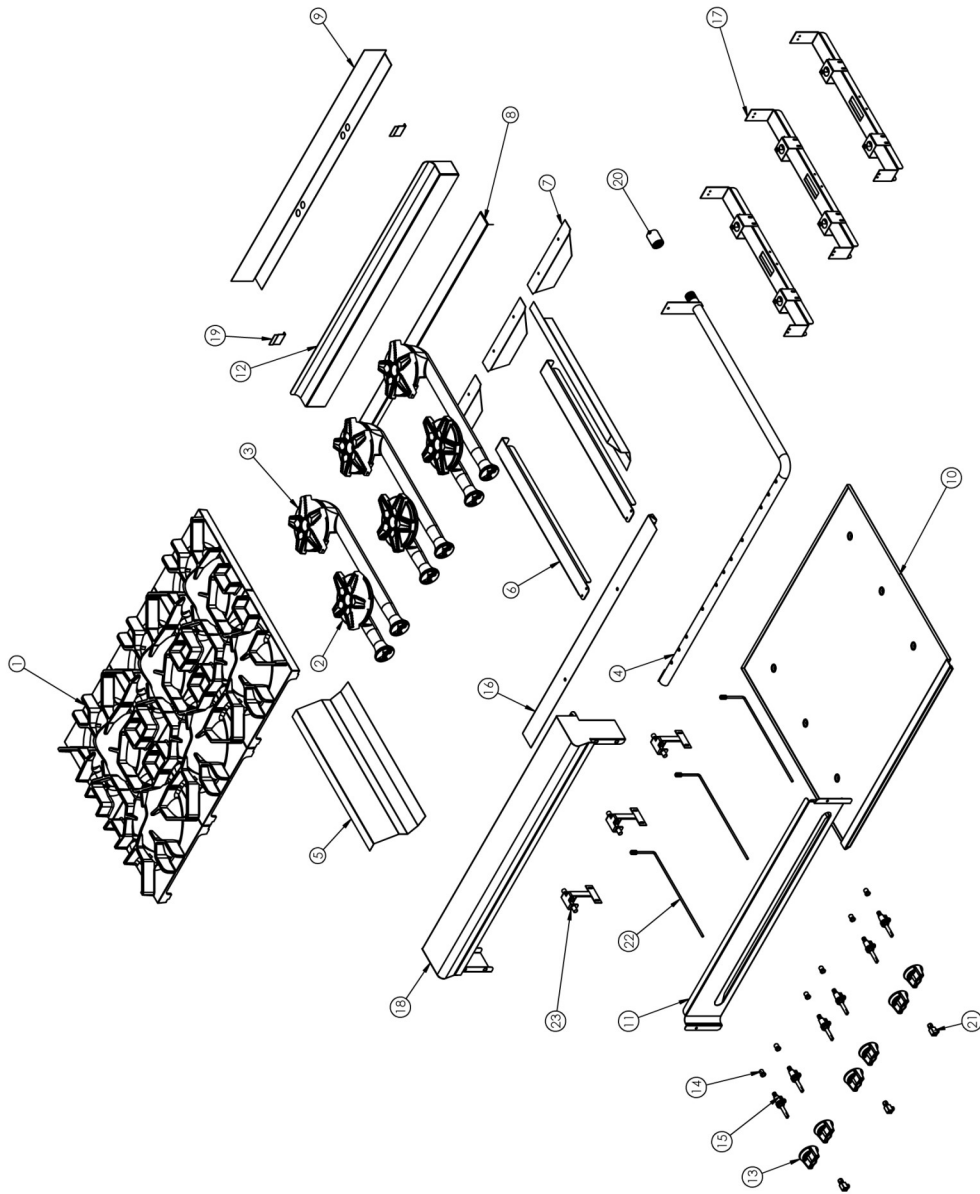

MONTAGUE TECHNOSTAR T60 OPEN TOP - EXPLODED VIEW

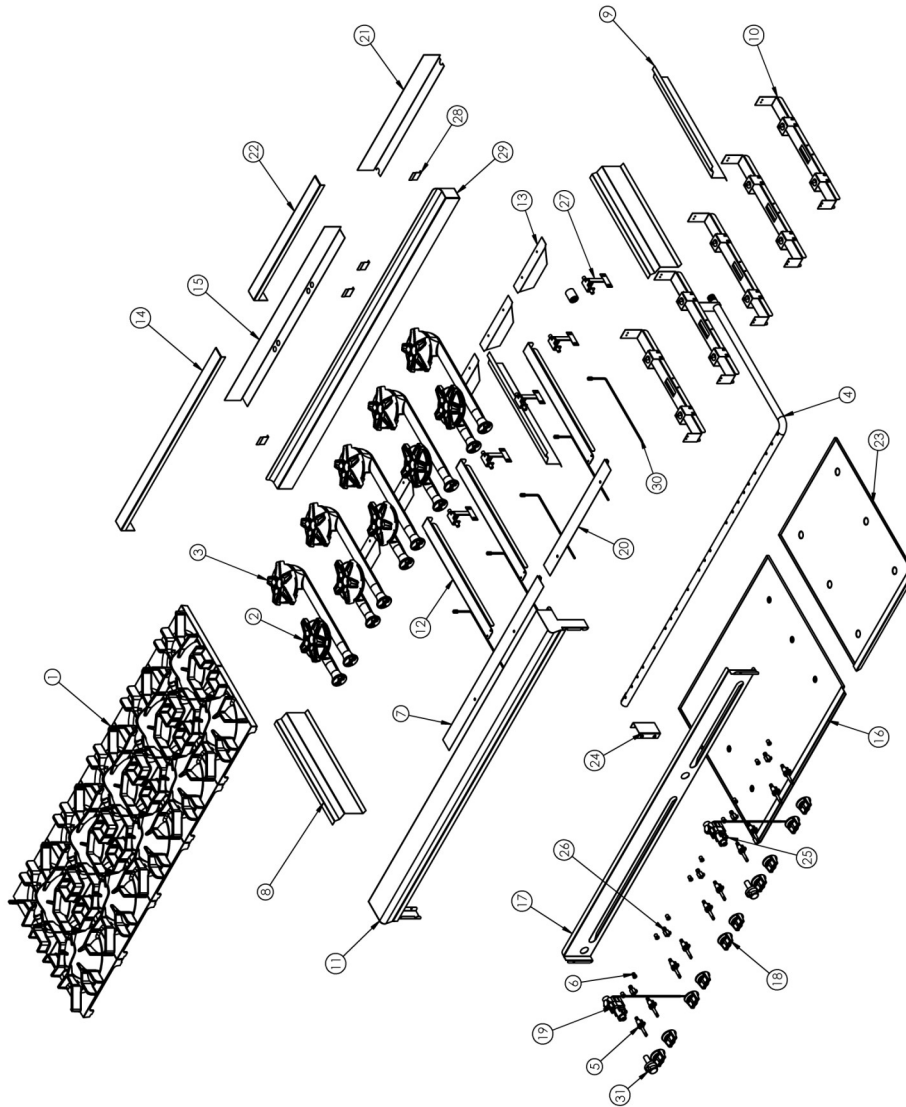

ITEM NO.	PART NUMBER	DESCRIPTION
1	45182-7	CASTING, GROUND
2	50244-8	BURNER ASSY
3	50242-1	BURNER ASSY
4	50798-9	MANIFOLD ASSY
5	02570-4	VALVE ASSY, BURNER
6	02567-4	ORIFICE, HOOD
7	16151-9	ORIFICE, HOOD (PROPANE)
8	51133-1	SUPPORT, FRONT - BURNER ASSY
9	50896-9	DEFLECTOR, DRIP
10	60286-8	DEFLECTOR, DRIP
11	59470-9	SUPPORT ASSY
12	52918-4	GUARD RAIL ASSY
13	50875-6	GRATE SUPPORT
14	50876-4	SHEET MTL - ALZD - P/F
15	51049-1	SHEET MTL - CR - P/F
16	51050-5	SHEET MTL - ALZD - P/F
17	51060-2	CONTAINER, DRIP W/ SS TRIM
18	51223-0	PANEL, CONTROL
19	50689-3	HANDLE, VALVE
20	11810-9	THERMOSTAT
21	51116-1	SUPPORT, FRONT - BURNER ASSY
22	50888-8	SHEET MTL-ALZD-P/F
23	50878-0	SHEET MTL - ALZD - P/F
24	50845-4	CONTAINER, DRIP W/ SS TRIM
25	27574-3	SHEET MTL - SS - P/F
26	02346-9	NIPPLE, W/ FLANGE MTG ASSY.
27	01055-3	VALVE, PILOT
28	59179-3	PILOT, FLASH TUBE
29	52841-2	SHEET MTL - SS - P/F
30	52919-2	SHEET MTL - SS - P/F
31	59436-9	LIGHTER, PILOT
32	26789-9	DIAL, THERMOSTAT
33	01125-8	COUPLING, PIPE
34	17613-3	NIPPLE, PIPE (NOT SHOWN)

MONTAGUE TECHNOSTAR T26 OVEN - EXPLODED VIEW

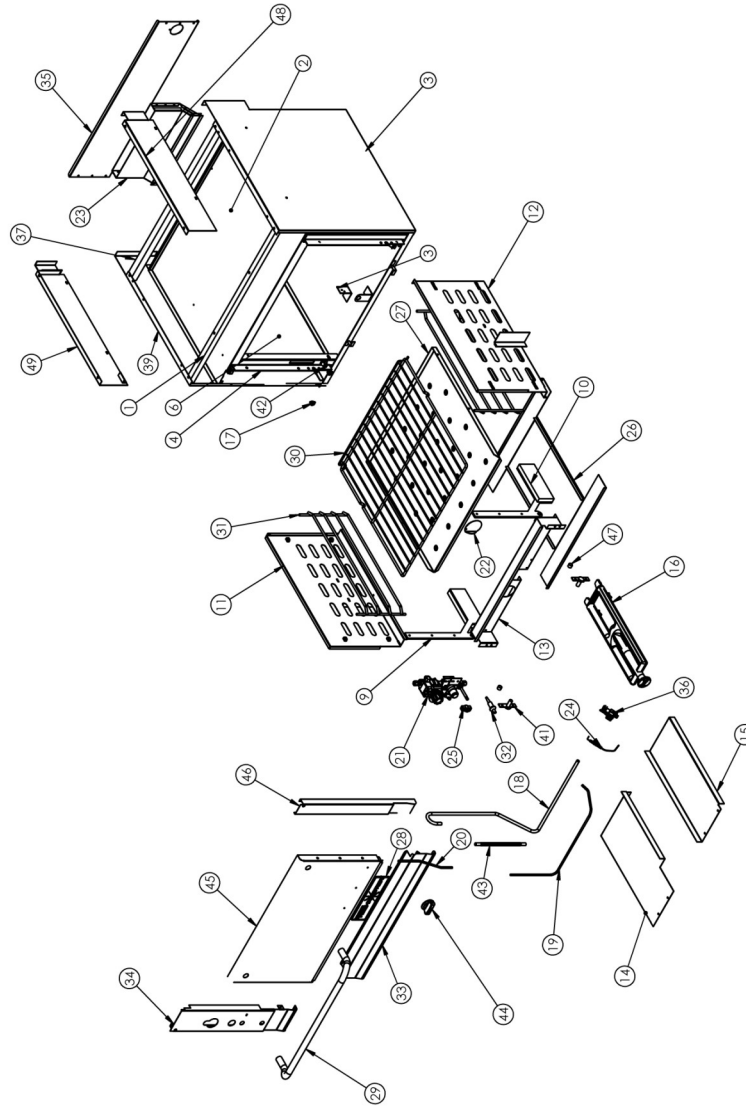

ITEM NO.	PART NUMBER	DESCRIPTION	ITEM NO.	PART NUMBER	DESCRIPTION
1	51045-9	ANGLE, FRONT ASSY.	33	51059-9	PANEL, BURNER ACCESS
2	51035-1	BURNER BOX, BOTTOM	34	51061-0	MULLION - LT ASSY
3	51018-1	BASE FRAME	35	51065-3	PANEL, BACK BURNER BOX
4	51024-6	FRAME, DOOR ASSY	36	50917-5	PILOT, OVEN ASSY
5	51348-2	PANEL, BACK ASSY (NOT SHOWN)	37	51047-5	ANGLE - HR - STRUCT - PUNCH
6	11687-4	LINER-REAR & SIDES ASSY	38	14605-6	REGULATOR (NOT SHOWN)
7	51033-5	LINER - TOP, OVEN IN (NOT SHOWN)	39	52854-4	PANEL, SIDE - LT ASSY
8	50847-0	SHEET MTL - CR - P/F (NOT SHOWN)	40	52754-8	PANEL, SIDE - RT
9	06079-8	TRUNNION ASSY - LT	41	60029-6	PIN ASSY, DOOR
10	06077-1	TRUNNION ASSY - RT	42	02204-7	CATCH, SPRING (FEMALE)
11	11608-4	LINER-SIDE LT, OVEN IN	43	46420-1	TUBING, SS/FLEX
12	11609-2	LINER-SIDE RT, OVEN IN	44	38485-2	HANDLE, VALVE w/HEX SCREW
13	51037-8	BURNER BOX - FRONT ASSEMBLY	45	55465-0	DOOR ASSY
14	51039-4	BAFFLE - AIR	46	51064-5	SHEET MTL - SS - P/F
15	51040-8	BAFFLE - AIR	47	01260-2	SPACER
16	03447-9	BURNER ASSY	48	59252-8	BURNER BOX - SIDE - RT ASSY
17	01942-9	CLIP	49	59254-4	BURNER BOX-SIDE; LT ASSY
18	51350-4	TUBING-AL-FORMED			
19	51352-0	TUBING-AL-FORMED			
20	51353-9	TUBING-AL-FORMED			
21	51041-6	TSTAT/SAFETY-CONTROL ASSY			
22	50945-0	DOOR, PILOT ACCESS			
23	50852-7	FLUE EXTENTION ASSY			
24	26871-2	ELECTRODE, OVEN			
25	22818-4	VALVE, PILOT			
26	03572-6	BAFFLE - FLAME ASSY			
27	11602-5	LINER-BOTTOM, OVEN IN			
28	51178-1	NAMEPLATE			
29	11776-5	HANDLE			
30	29099-8	RACK, WIRE			
31	07223-0	GUIDE, RT/LT - RACK			
32	25716-8	IGNITER W/ NUT PIEZO			

MONTAGUE TECHNOSTAR T60 OVEN - EXPLODED VIEW

ITEM NO.	PART NUMBER	DESCRIPTION	ITEM NO.	PART NUMBER	DESCRIPTION
1	16319-8	BASE FRAME	45	59265-2	BURNER BOX SIDE: LT ASSY
2	51237-0	LINER - REAR + SIDES	46	59257-9	BURNER BOX SIDE: LT ASSY
3	51239-7	LINER - REAR + SIDES ASSY - RT	47	59268-7	BURNER BOX SIDE: RT ASSY
4	51241-9	BURNER BOX - BOTTOM	48	59266-0	BURNER BOX SIDE: RT ASSY
5	51242-7	PANEL BACK (NOT SHOWN)	49	51045-9	ANGLE, FRONT ASSY.
6	01942-9	CLIP	50	50870-5	ANGLE, FRONT ASSY.
7	11852-9	SHEET MTL - ALZD - P/F	51	13534-8	PANEL SIDE - INNER LT
8	11854-0	DOOR - PILOT ACCESS	52	13532-1	PANEL SIDE - INNER RT
9	51245-1	TRUNNION ASSY - LT	53	06926-4	CATCH SPRING, FEMALE
10	51244-3	TRUNNION ASSY - RT	54	50872-1	ANGLE - HR - STRUCT - PUNCH
11	23855-4	LINER - SIDE LT, OVEN IN	55	51047-5	PUNCH
12	23856-2	LINER - SIDE RT, OVEN IN			
13	03447-9	BURNER ASSY			
14	23283-1	BAFFLE - AIR			
15	23282-3	BAFFLE - AIR			
16	50852-7	FLUE EXTENSION ASSY			
17	22499-5	SHEET MTL - ALZD - P/F			
18	26871-2	ELECTRODE, OVEN			
19	51243-5	SHEET MTL - CR - P/F			
20	03572-6	BAFFLE - FLAME ASSY			
21	11602-5	LINER-BOTTOM, OVEN IN			
22	07223-0	GUIDE- RT/LT - RACK			
23	29099-8	RACK, WIRE			
24	51178-1	NAMEPLATE			
25	11776-5	HANDLE			
26	25716-8	IGNITER W/ NUT PIEZO			
27	22514-2	SHEET MTL - SS - P/F			
28	51256-7	PANEL BACK - BURNER BOX			
29	06375-4	ORIFICE, ELBOW ASSY			
30	24084-2	PILOT, OVEN ASSY			
31	14607-2	REGULATOR PRESSURE (NOT SHOWN)			
32	51225-7	FRAME, DOOR ASSY			
33	22481-2	LINER - TOP, OVEN IN (NOT SHOWN)			
34	55223-9	PIN ASSY, DOOR			
35	54025-0	PIN ASSY, DOOR			
36	55749-8	VALVE ASSY, SAFETY			
37	59839-9	INSULATION PANEL - LT			
38	59838-0	INSULATION PANEL - RT			
39	59891-7	INSULATION - CUT TO SIZE			
40	59890-9	INSULATION - CUT TO SIZE			
41	52785-8	PANEL SIDE - LT			
42	52783-1	PANEL SIDE - RT			
43	52807-2	PANEL BURNER ACCESS			
44	55465-0	DOOR ASSY			

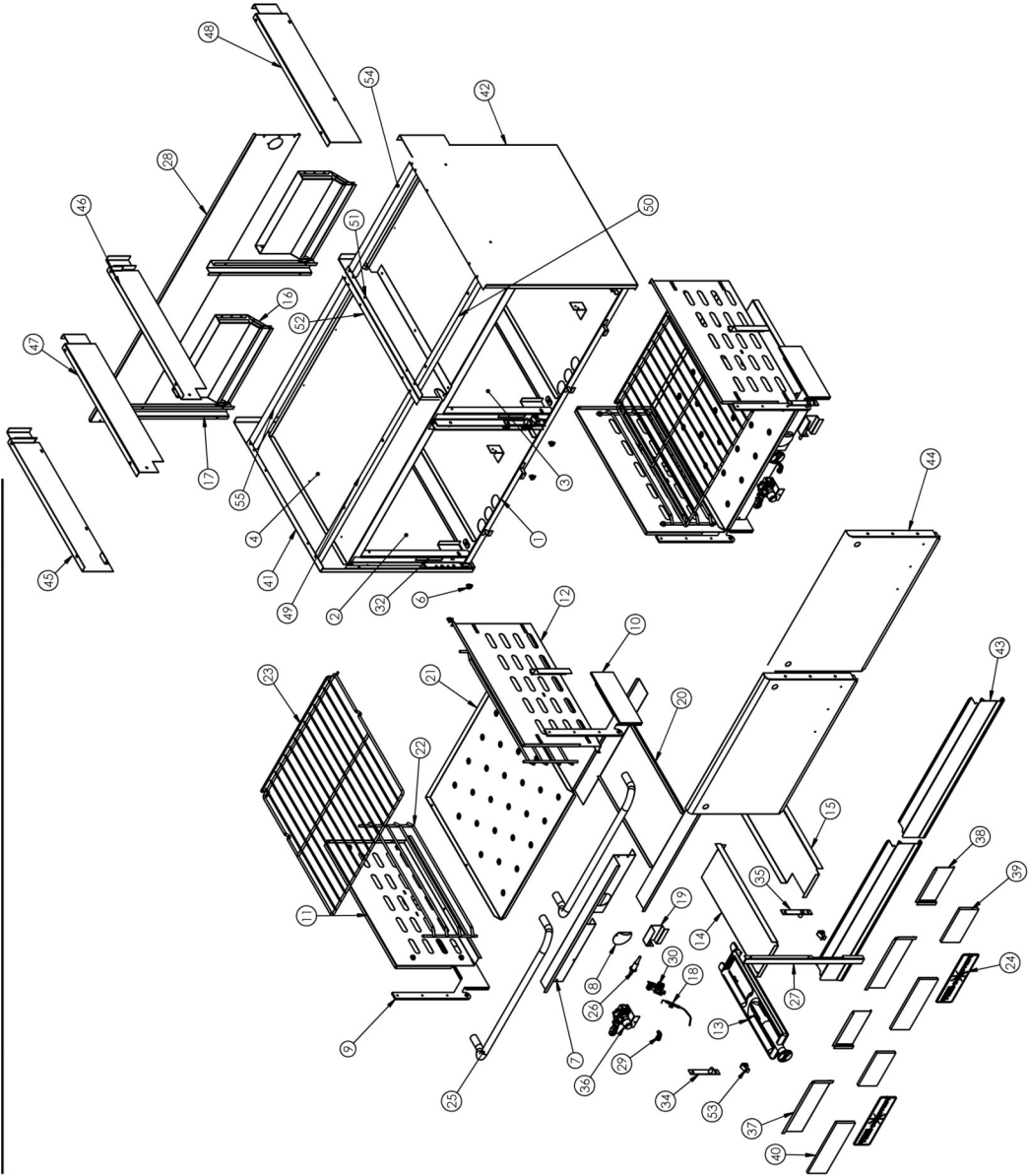

MONTAGUE TECHNOSTAR VT SERIES - VT26 OVEN
EXPLODED VIEW

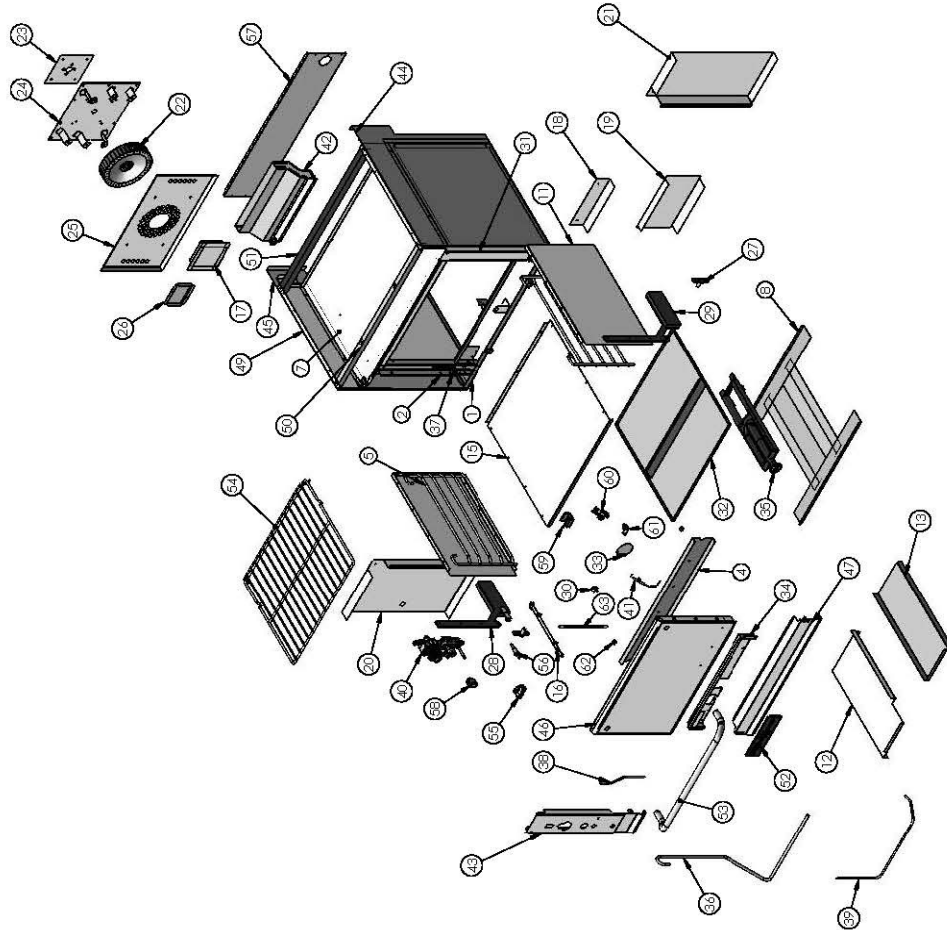

ITEM NO.	PART NUMBER	DESCRIPTION	ITEM NO.	PART NUMBER	DESCRIPTION
1	52082-9	BASE FRAME	37	11350-6	WASHER, FLAT-PLT
2	52079-9	FRAME, DOOR ASSY	38	51353-9	TUBING-AL-FORMED
3	52078-0	PANEL, BACK (NOT SHOWN)	39	51352-0	TUBING-AL-FORMED
4	09130-3	SHEET MTL - CR - P/F	40	51041-6	1STAT/SAFETY-CONTROL ASSY
5	02345-5	GUIDE-RT/LT, RACK	41	24671-2	ELECTRODE, OVEN
6	09098-0	LINER, TOP, OVEN IN (NOT SHOWN)	42	52089-6	FLUE DEFLECTOR ASSY
7	52096-9	BURNER BOX - BOTTOM	43	52131-0	MILLION - LT ASSY
8	09095-6	BAFFLE - FLAME	44	52954-0	PANEL, SIDE - RT ASSY
9	52098-5	LINER - INSULATION (NOT SHOWN)	45	52955-9	PANEL, SIDE - LT ASSY
10	24672-7	LINER - INSULATION (NOT SHOWN)	46	55465-0	DOOR ASSY
11	09118-9	LINER - SIDE LT /RT - OVEN	47	51059-9	PANEL, BURNER ACCESS
12	52111-6	BAFFLE - AIR	48	59252-8	BURNER BOX - SIDE - RT ASSY (NOT SHOWN)
13	52109-4	BAFFLE - AIR	49	59254-4	BURNER BOX-SIDE: LT ASSY
14	52085-3	LINER, TOP - FLUE (NOT SHOWN)	50	51045-9	ANGLE, FRONT ASSY.
15	02426-0	LINER, BOTTOM - OVEN IN	51	51047-5	ANGLE - HR - STRUCT - PUNCH
16	18476-4	HOLDER ASSY, RT D SENSOR	52	51178-1	NAMEPLATE
17	09346-9	JUNCTION BOX ASSY	53	11776-5	HANDLE
18	11009-4	PANEL, REAR-TOP CENTER	54	02344-7	BACK WIRE
19	11010-8	PANEL, REAR-LOWER CENTER	55	38485-2	HANDLE, VALVE W/HEX SCREW
20	52134-5	PANEL, REAR - LEFT	56	25716-8	IGNITER W/ NUT PIEZO
21	52132-9	PANEL, REAR - RT	57	51065-3	PANEL, BACK, BURNER BOX
22	02123-7	BLOWER WHEEL	58	46429-5	SWITCH, ROCKER
23	06333-9	SHEET MTL-CR-P/F	59	52117-5	SWITCH ASSY
24	09086-7	PLATE ASSY, MOTOR MITG - REAR	60	50917-5	PILOT, OVEN ASSY (NATURAL)
25	09082-4	BAFFLE - REAR, FAN	61	24083-4	PILOT, OVEN ASSY (PROPANE)
26	17515-3	COVER, ELEC ENCL	62	02666-2	ORIFICE, ELBOW ASSY (NATURAL)
27	60029-6	PIN ASSY, DOOR	63	09312-2	ORIFICE, ELBOW ASSY (PROPANE)
28	52108-6	TRUNNION ASSY, LT W/ BRACKET	64	01260-2	SPACER
29	06077-1	TRUNNION ASSY - RT	65	46420-1	TUBING - SS/FLEX
30	02284-7	CATCH, SPRING (FEMALE)	66	01395-1	BUSHING, STRAIN RELIEF (NOT SHOWN)
31	51064-5	SHEET MTL - SS - P/F	67	09106-5	CONDUIT, FLEX-CUT TO SIZE (NOT SHOWN)
32	06138-7	BAFFLE - HEAT ASSY	68	15902-6	CONDUIT, FLEX-CUT TO SIZE (NOT SHOWN)
33	50946-0	DOOR, PILOT ACCESS	69	06265-0	MOTOR (HOWELL) (NOT SHOWN)
34	52101-9	BURNER BOX - FRONT	70	01389-7	CLAMP, RACK, GUIDE (NOT SHOWN)
35	03447-9	BURNER ASSY	71	34980-1	CORD, ELECTRIC-6 (NOT SHOWN)
36	51350-4	SHEET MTL - SS - P/F	72	15904-2	WIRE ASSY VT26 (NOT SHOWN)
			73	14605-6	REGULATOR, PRESSURE, (NOT SHOWN)
			74	01040-5	REGULATOR, PRESSURE (PROPANE) (NOT SHOWN)

**MONTAGUE TECHNOSTAR - FRY TOP SECTION, MANUAL CONTROL
EXPLODED VIEW**

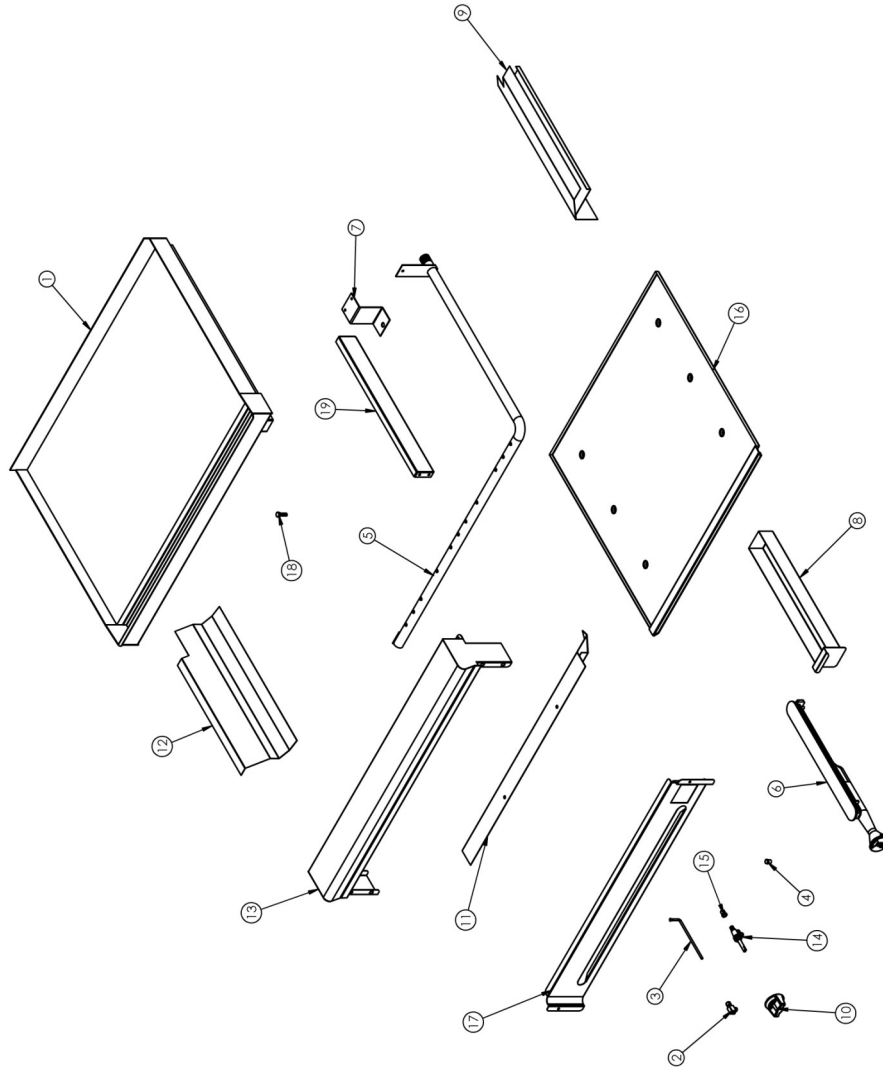

ITEM NO.	PART NUMBER	DESCRIPTION
1	51838-7	FRYTOP-1FT
	51783-6	FRYTOP-2FT
	51788-7	FRYTOP-3FT
	51789-5	FRYTOP-4FT
	51799-2	FRYTOP-5FT
	51796-8	FRYTOP-6FT
2	01055-3	VALVE, PILOT
3	03415-0	LIGHTER, PILOT: 3/16 OD X 1 1/4 X 6
4	01279-3	PLUG (BR), PIPE ASSY
5	50795-4	MANIFOLD ASSY
6	03361-8	BURNER ASSY
7	14146-1	SUPPORT, BURNER
8	51647-3	CONTAINER, GREASE - T - FT
9	51672-4	DEFLECTOR, DRIP
10	50472-6	HANDLE, VALVE
11	51753-4	SUPPORT, FRONT - BURNER ASSY
12	52405-0	DEFLECTOR, DRIP
13	52877-3	GUARD RAIL ASSY
14	02570-4	VALVE ASSY, BURNER
	01006-5	VALVE ASSY, BURNER (PROPANE)
15	06381-9	ORIFICE, HOOD
16	51051-3	CONTAINER, DRIP w/SS TRIM
17	51748-8	PANEL, CONTROL
18	01869-4	SCREW, CAP - PLIN
19	14144-5	SHEET MTL - CR - P/F
20	01920-8	NUT, RETAINER (NOT SHOWN)

MONTAGUE TECHNOSTAR - FRY TOP SECTION, THERMOSTAT CONTROL
EXPLODED VIEW

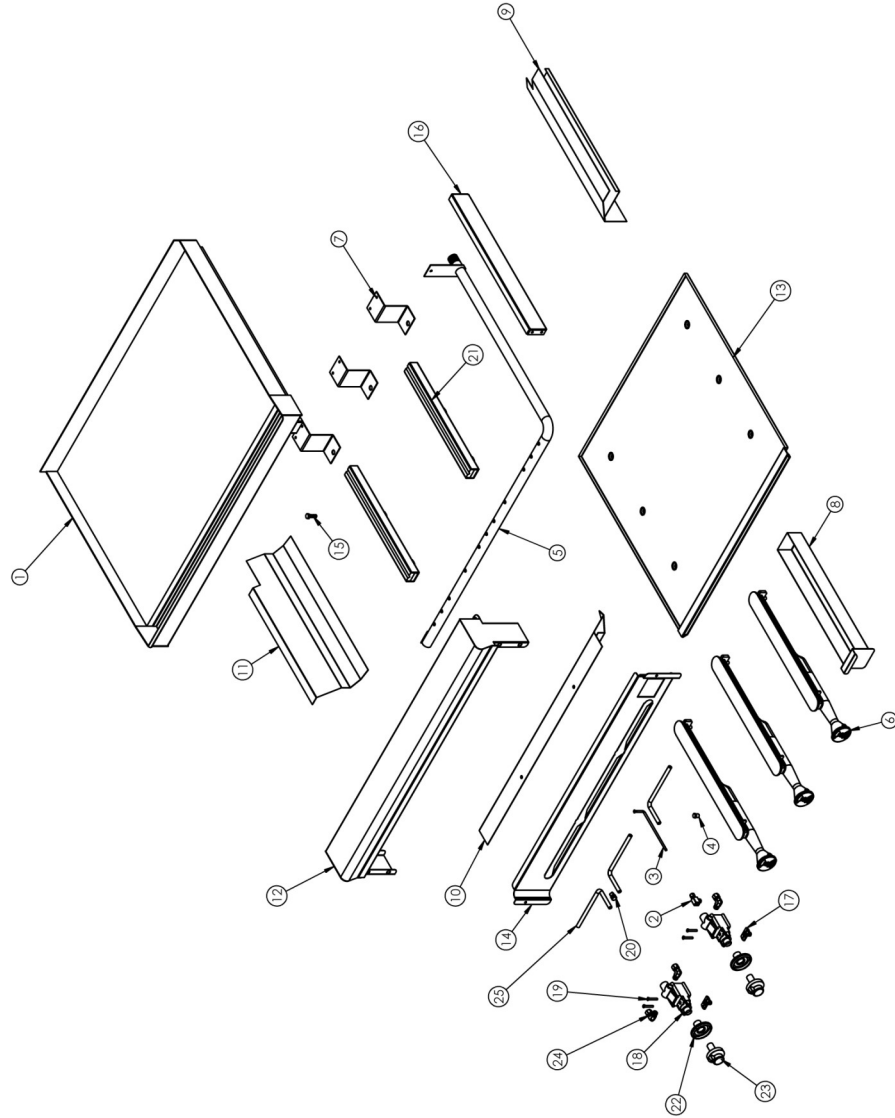

ITEM NO.	PART NUMBER	DESCRIPTION
1	51843-3	FRYTOP-36IN W/ 3/4" PLATE
2	01055-3	VALVE, PILOT
3	03415-0	LIGHTER, PILOT; 3/16 OD X 1 1/4 X 6
4	01279-3	PLUG (BR), PIPE ASSY
5	50795-4	MANIFOLD ASSY
6	03361-8	BURNER ASSY
7	14146-1	SUPPORT, BURNER
8	51647-3	CONTAINER, GREASE - T - FT
9	51672-4	DEFLECTOR, DRIP
10	51753-4	SUPPORT, FRONT - BURNER ASSY
11	52405-0	DEFLECTOR, DRIP
12	52877-3	GUARD RAIL ASSY
13	51051-3	CONTAINER, DRIP w/SS TRIM
14	53796-9	PANEL, CONTROL
15	01869-4	SCREW, CAP - PLN
16	14144-5	SHEET MTL - CR - P/F
17	02336-1	NIPPLE, w/FLANGE MTG.
18	01067-7	THERMOSTAT
19	16893-9	SCREW, CAP w/WASHER - PLT
20	01173-8	PLUG, SQUARE
21	03386-3	HOLDER ASSY, SENSING BULB
22	26870-4	BEZEL
23	26869-0	DIAL, THERMOSTAT
24	01285-8	ELBOW-MALE, PXT
25	08566-9	TUBING - AL - FORMED
26	01920-8	NUT, RETAINER (NOT SHOWN)
27	14612-9	ORIFICE, ELBOW ASSY (NOT SHOWN)
	03385-5	ORIFICE, ELBOW ASSY (PROPANE)

NOTES

NOTES

WARNING

If not installed, operated and maintained in accordance with the manufacturer's instructions, this product could expose you to substances in fuel or in fuel combustion which can cause death or serious illness and which are known to the State of California to cause cancer, birth defects

The State of California enacted the California Safe Drinking Water and Toxic Enforcement Act of 1986, (Prop. 65), which "prohibits any person in the course of doing business from knowingly and intentionally exposing any individual to a chemical known to the State of California to cause cancer or reproductive toxicity without first giving clear and reasonable warning to such individuals." The Governor's Scientific Advisory Panel added carbon monoxide to the list of hazardous chemicals known to cause reproductive harm.

In order to establish full compliance with Proposition 65, we attached a yellow warning label to each gas fired unit manufactured by the Montague Company.

Carbon monoxide would not be present in concentrations that would pose a "significant risk" to the consumer when the equipment is installed, operated and maintained as follows:

1. Installed in accordance with all local codes, or in the absence of local codes, with the current National Fuel Gas Code Z223.1.
2. Installed under a properly designed and operating exhaust hood.
3. Connected to the type of gas for which the unit is equipped.
4. Proper appliance pressure regulator installed on the gas supply line and adjusted for the manifold pressure marked on the rating plate.
5. Adequate air supply to the unit.
6. The equipment is operated in the manner intended using the proper utensil for that type of appliance.
7. Keep the equipment clean and have it checked periodically.
8. Burner air adjustments, mechanical maintenance and repairs should be performed by qualified service personnel.

If the equipment is not installed, operated and maintained in accordance with the above, concentrations of carbon monoxide in excess of the established limits could present in the kitchen environment.

ALL PERSONNEL IN THE WORKPLACE WHO MAY BE SUBJECT TO ANY EXPOSURE OF CARBON MONOXIDE MUST BE WARNED OF SUCH POSSIBLE EXPOSURE. THIS WARNING SHOULD BE CONVEYED IN A MANNER SO THAT IT IS CLEARLY UNDERSTOOD BY THE EMPLOYEE, AND THE EMPLOYEE SHOULD BE ASKED IF IN FACT HE OR SHE UNDERSTANDS THE CORRECT METHOD OF OPERATION OF THE EQUIPMENT AND THAT A RISK OF EXPOSURE EXISTS IF THE EQUIPMENT IS OPERATED IMPROPERLY.



The MONTAGUE Company

1830 Stearman Ave. • P.O. Box 4954 • Hayward, CA 94540-4954

Tel: 510/785-8822 • Fax: 510/785-3342

REV. B P/N 52455-7 4/15