

Mars Air Systems

Typical Air Curtain Wiring Diagrams

Table of Contents

Unheated Wiring Diagrams

Typical Wiring Diagrams.....	3
LPV2/LPN2 115v Motor.....	4
LPV2/LPN2 208/230v Motor.....	5
Door Limit Switches.....	6
Three Speed Switch and Cord.....	7
VFD with Variable Speed Control.....	8
RIB ½ HP with No Time Delay.....	9
RIB ½ HP with Time Delay.....	10
RIB 1 HP with No Time Delay	11
RIB 1 HP with Time Delay	12
RIB 1 HP with Time Delay and 2 Speed Switch.....	13
RIB ½ HP with Two Door Switches.....	14
Typical Motor Control Panel (MCPA-1UA)	15
Typical Motor Control Panel with Time Delay and Three Speed (MCPA-1UA-TD-3S)	16
Typical Motor Control Panel with BMS Control & Monitor (MCPA-3UH-303)	17
SimpleLink 2 Controller with TRIAC for LPV2 (MCPS-2UA-SK2)	18
SimpleLink 2 Controller with Remote VFD for STD2 (MCPA-2UG-SK2-VR)	19

Hot Water/Steam Heated Wiring Diagrams

Typical HW/S (1 Ph, 1Hp max)	20
LPV2 HW/S with Heat on Demand	21
Typical HW/S with RIB.....	22



HW/S Motor Control Panel (MCPB-2VD)	23
HW/S Motor Control Panel with Heat on Demand (MCPB-2VD-HD)	24
HW/S Motor Control Panel with BMS Monitor & Control (MCPB-3VH-306)	25

Electric Heated Wiring Diagrams

Electric Heated LPV2, 1 Mtr, 208/230v, 3ph	26
Electric Heated LPV2, 1 Mtr, 460v, 3ph Heater, 115v, 1ph Motor	27
Electric Heated LPV2, 1 Mtr, 460v, 3ph Heater, 115v, 1ph Motor, SimpleLink 2 Controller.....	28
Electric Heated STD2, 2 Mtr, 208/230v, 3ph	29
Electric Heated STD2, 2 Mtr, 460v, 3ph, Adj TD	30
Electric Heated STD2, 2 Mtr, 460v, 3ph, SimpleLink 2 Controller	31

Typical Wiring Diagrams

SINGLE PHASE

TYPICAL UNHEATED DIAGRAMS

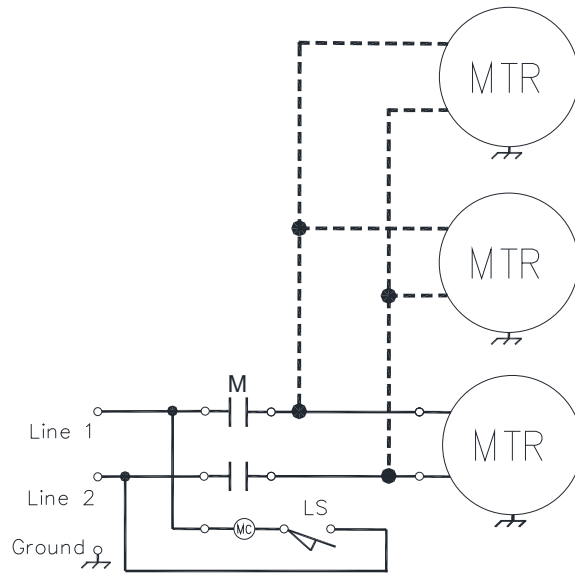
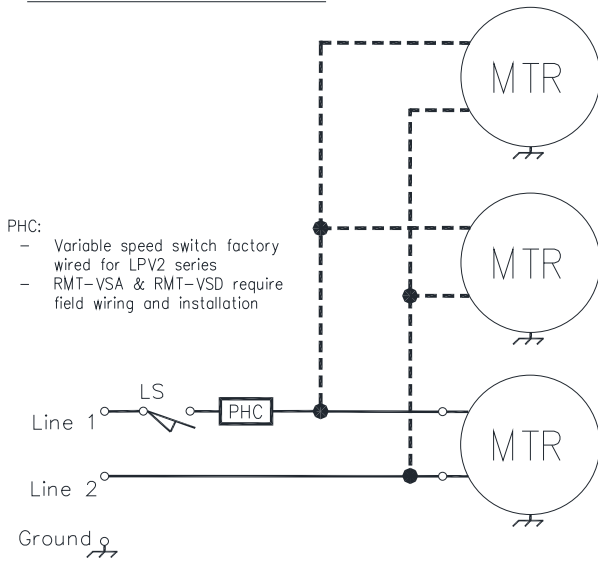

120/208-240/277v Single Phase Motor

- 1/6 H.P. Use 15A Micro Switch
- 1/2 H.P. Use 15A Micro Switch
- 1 H.P. Use 20A Micro Switch

LS: Limit Switch. Wire as Normally Closed (COM & NC)
 Max Rating: Upto 1 HP, 250VAC, 1PH

120/208-240/277v Single Phase Motor

Larger than 1 H.P. Use Contactor and 15A Micro Switch

THREE PHASE

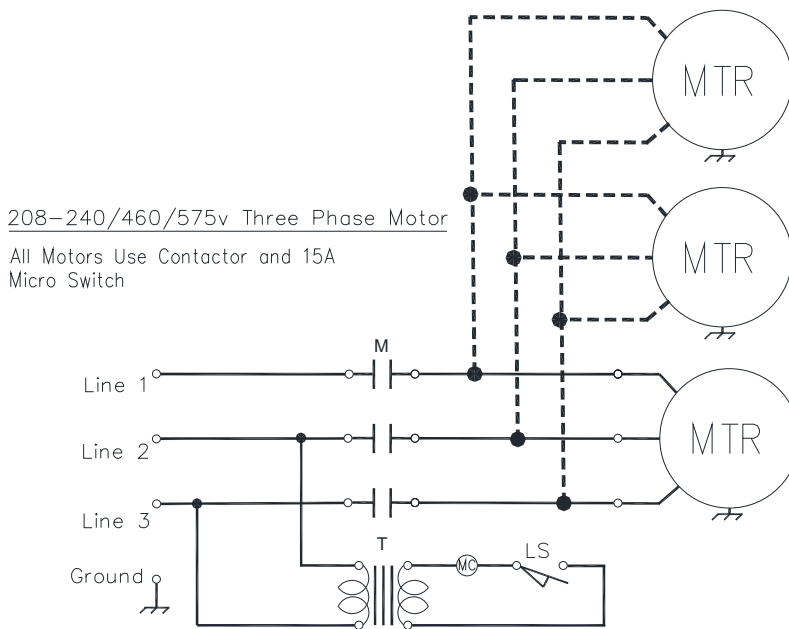

208-240/460/575v Three Phase Motor

All Motors Use Contactor and 15A Micro Switch

Typical Single Phase Motor Terminal Connections:

For 1/2 HP: <1> is Common for 115V

<1> is Hot for 208/230V

<2> is Low Speed

<3> is High Speed

<4> is Ground

<5> is Medium Speed

For 1 HP: <1> is Common for 115V, 208/230V

<2> is High Speed

<3> is Low Speed

<4> is Ground

Notes: This wiring diagram is applicable for Single Phase motors as follows:

LPV2: Up to 3 motors

STD2: Up to 2 motors

HV2: 1 motor

*See Door Limit Switch submittal for additional switch info

S Y M B O L S

LS - Micro Switch

M - Contactor or Motor Starter

MC - Contactor Coil

T - Control Transformer

PHC - Speed Controller (LPV series only)

LPV2/LPN2 115v Motor

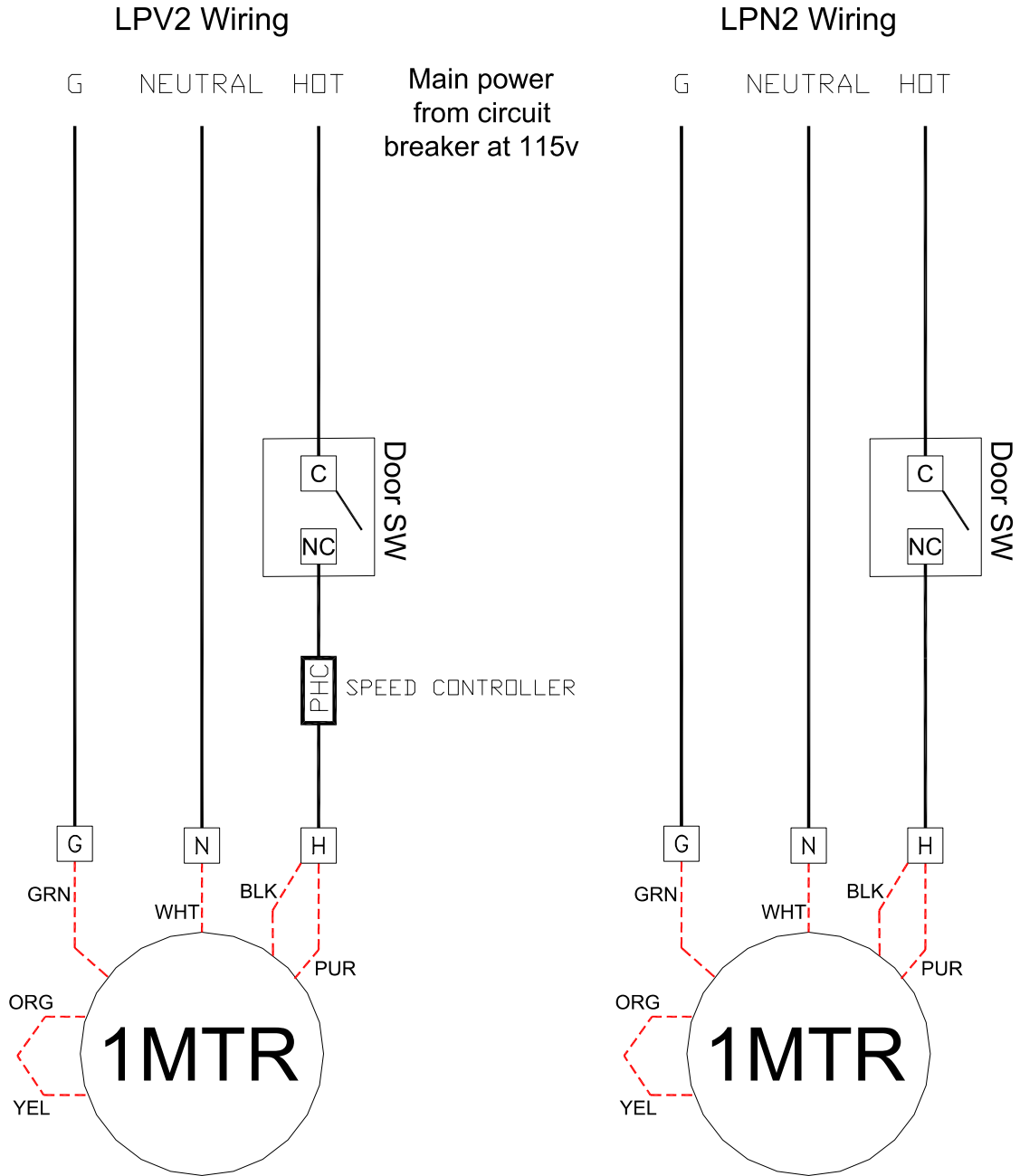

LPV2/LPN2 208/230v Motor

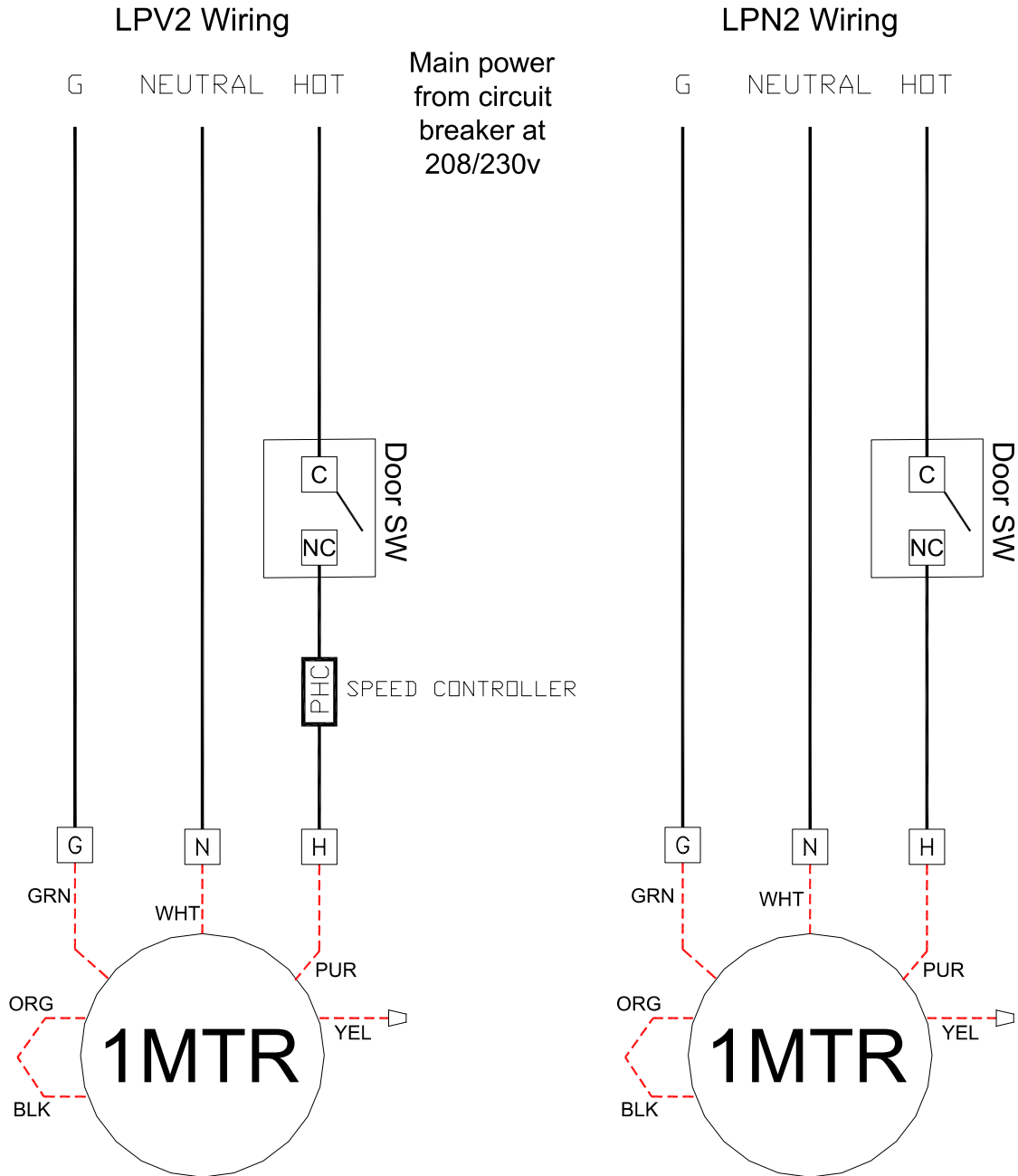

Door Limit Switches

How to Properly Wire Mechanical Door Limit Switches

Note: Please follow the wiring diagram included with the optional door limit switch purchased.

For the Mechanical types: (99-012, 99-013, 99-014, 99-015, 99-016, 99-267)

DO NOT GROUND the "COM" terminal

Damage caused by grounding the COM will not be covered under warranty.

There is a marked and/or green ground terminal provided.

COM is defined as the common terminal that supplies power to the N/C (Normally Closed) and N/O (Normally Open) terminals. Grounding the COM terminal will short the breaker and/or burn fuses, transformers and possibly motors. Typically, only 2 terminals, the COM and either the N/C or N/O, are used for standard applications.



atmosphere is everything

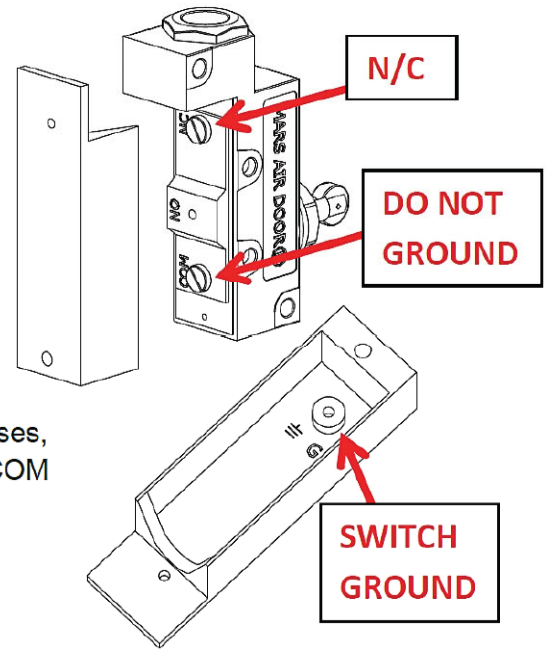

How to Properly Wire Magnetic Door Limit Switches

Note: Please follow the wiring diagram included with the optional door limit switch purchased.

For the Magnetic types: (99-018, 99-118, 99-124, 99-125, 99-275)

DO NOT GROUND the Green or White wires or COM (24V) terminals

Damage caused by grounding them will not be covered under warranty. The switch is grounded (except 24V) when the shielded cable provided is connected to a j-box.

COM is defined as the common terminal wire that supplies power to the N/C (Normally Closed) and N/O (Normally Open) terminal wires. Grounding the green or white terminal wires will short the breaker and burn the magnetic switches. Typically, only 2 terminals wires, either the N/C or N/O, are used for standard applications.



atmosphere is everything

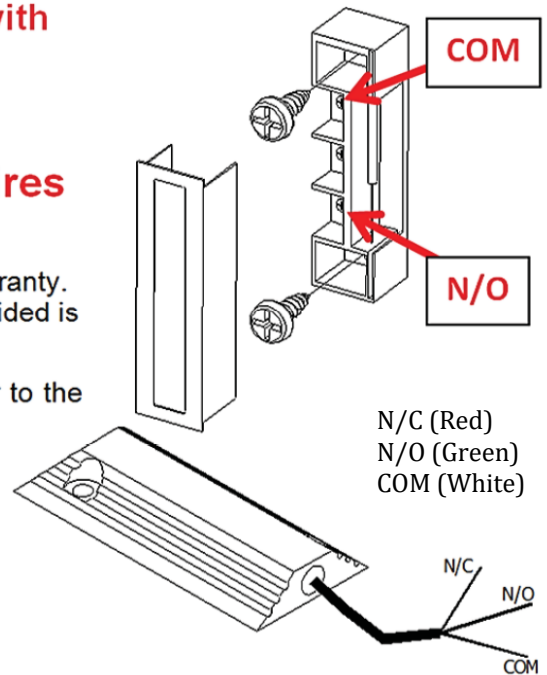

Three Speed Switch and Cord

Three Speed, (2) Single Phase, 1/2 HP Motor Plug and Switch Connection.
(FIELD WIRING - - - - -)

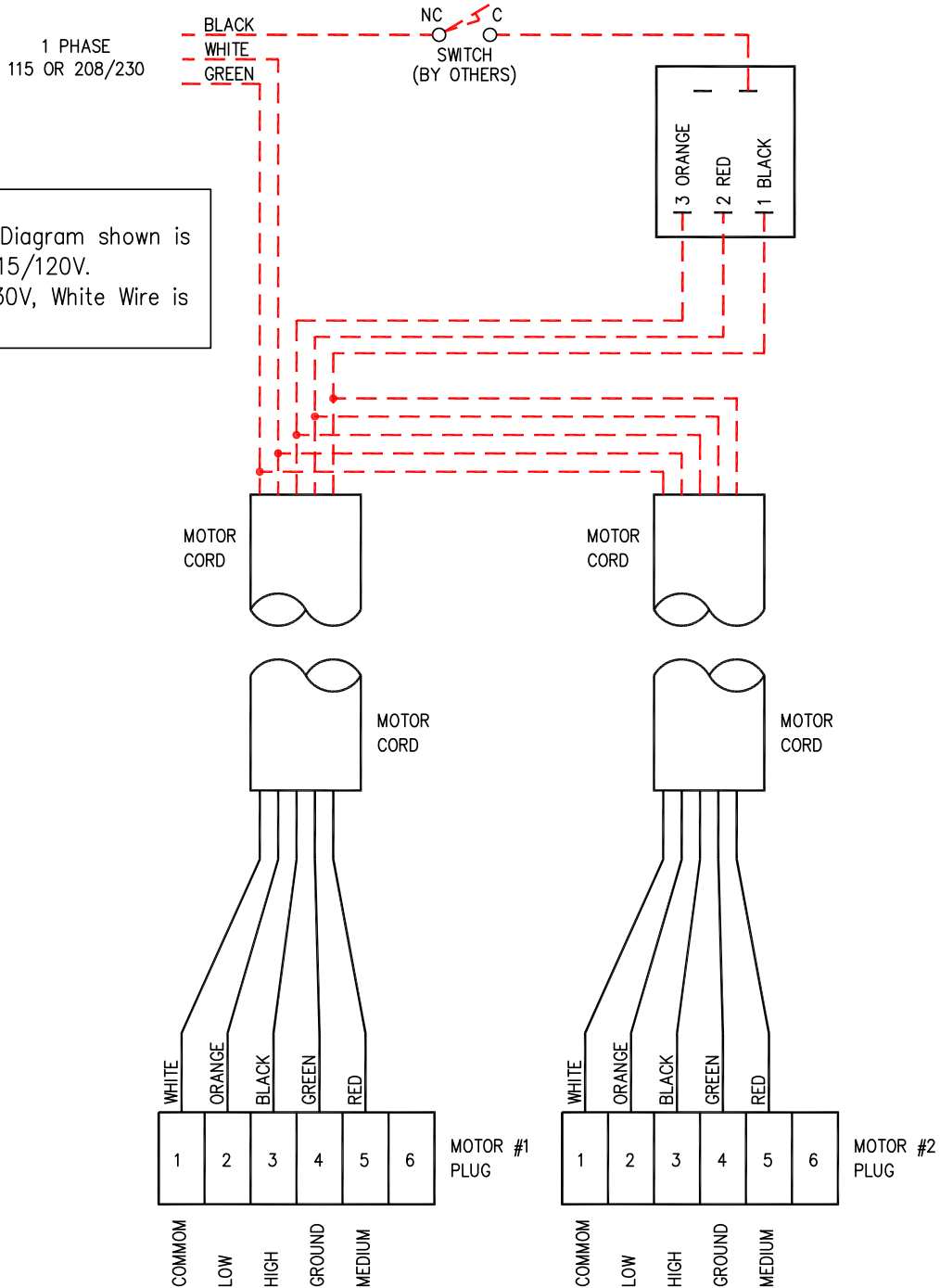

NOTE:
The Wiring Diagram shown is
wired for 115/120V.
For 208/230V, White Wire is
Hot.

COMBI-WIRE-2MTR 10/17/14 NT

VFD with Variable Speed Control

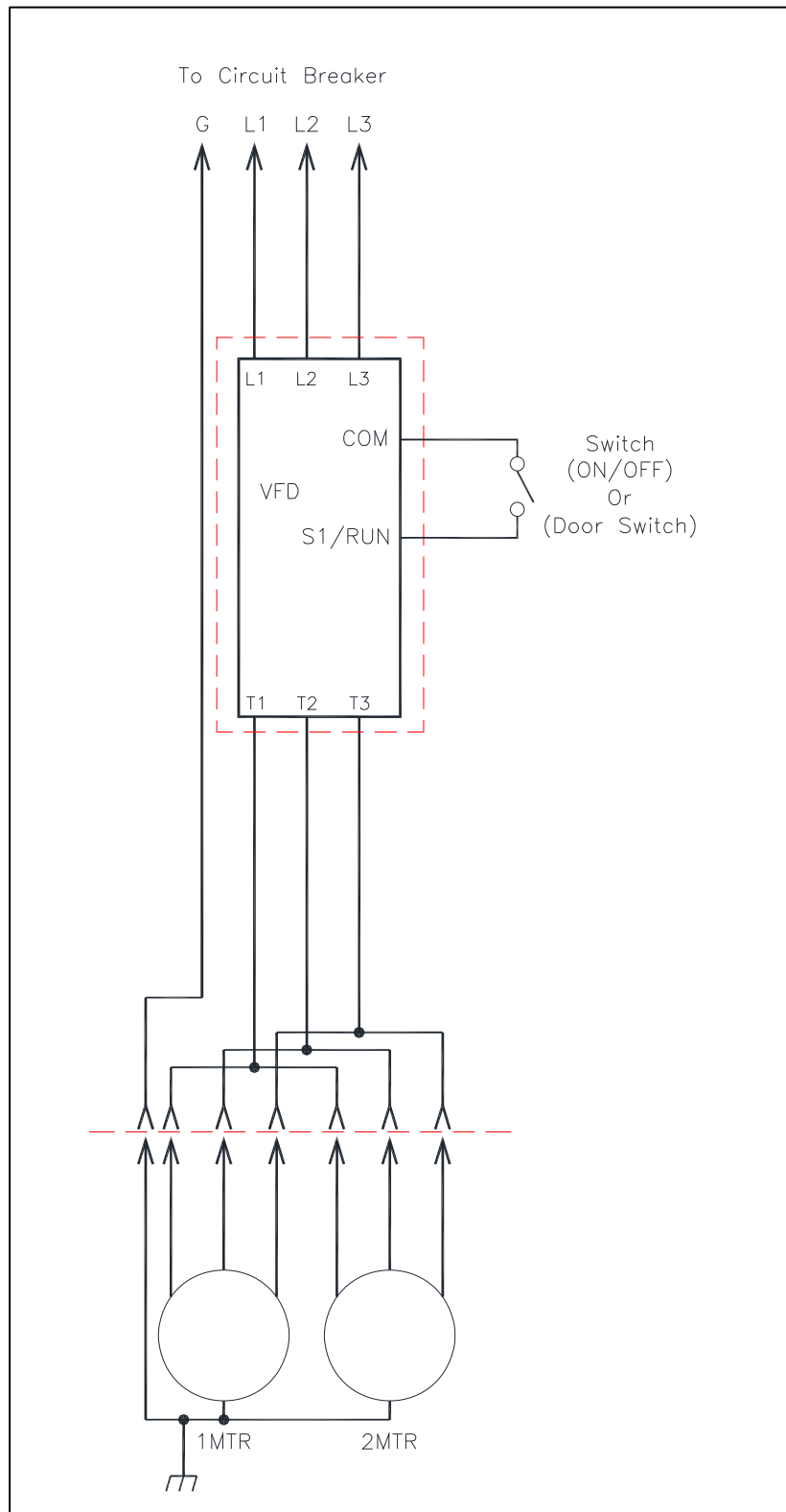

RIB, ½ HP with No Time Delay

RIB Kit Rating:

- 115v or 208-230v
- 1/2 HP Max

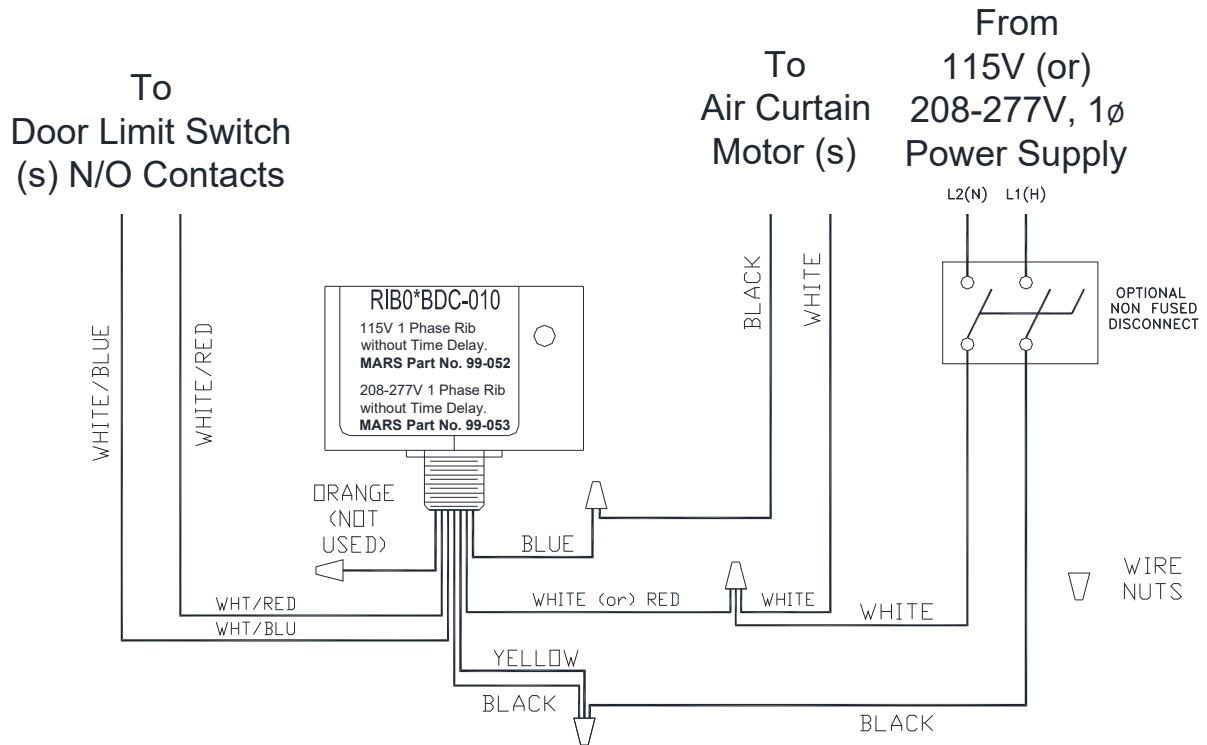

RIB Kit Part Numbers:

- 115v/1Ø
- [J0023](#), J0036, J0100
- 208-230v/1Ø
- [J0024](#), J0037, J0104

Note:
The controllers are wired the same, but are not interchangeable.

RIB, 1/2 HP with Time Delay

RIB Kit Rating:

- 115v or 208-230v
- 1/2 HP Max
- Adjustable Time Delay

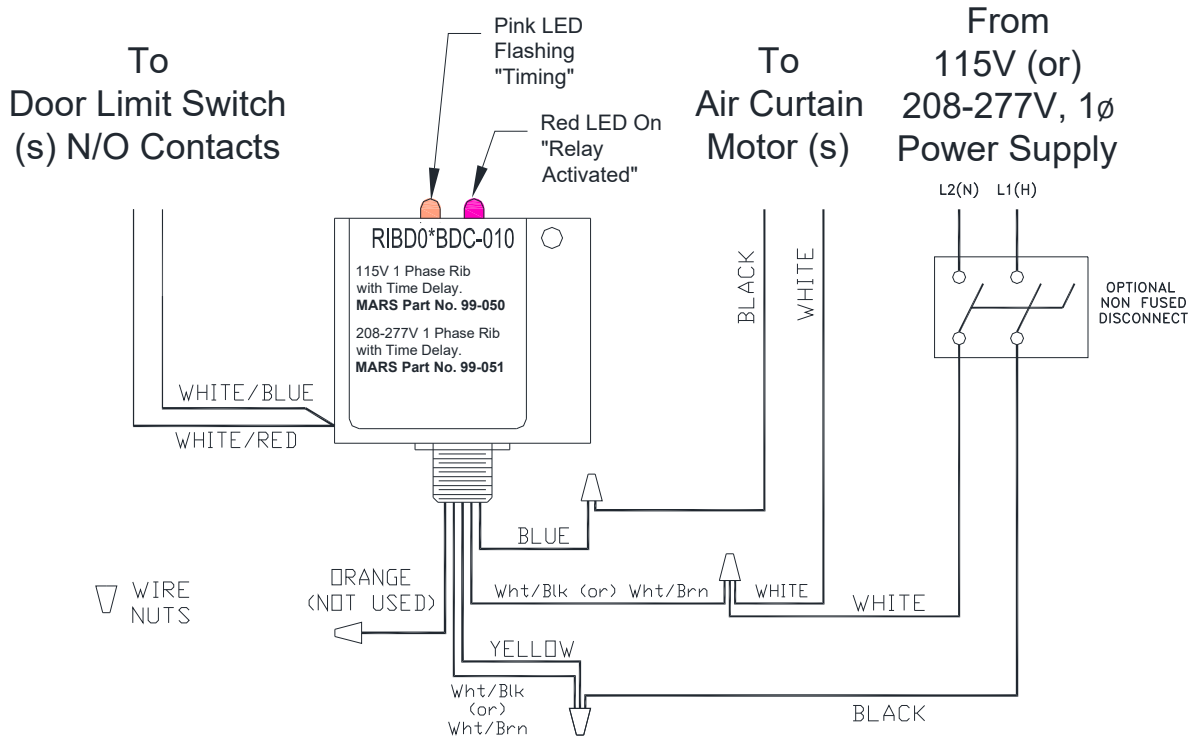

RIB Kit Part Numbers:

- 115v/1Ø
 - J0021, J0028, J0038, J0102
- 208-230v/1Ø
 - J0022, J0029, J0042, J0106

Note:
The controllers are wired the same, but are not interchangeable.

RIB, 1 HP with No Time Delay

RIB Kit Rating:

- 115v or 208-230v
- 1 HP Max (1.5HP for 208-230v)

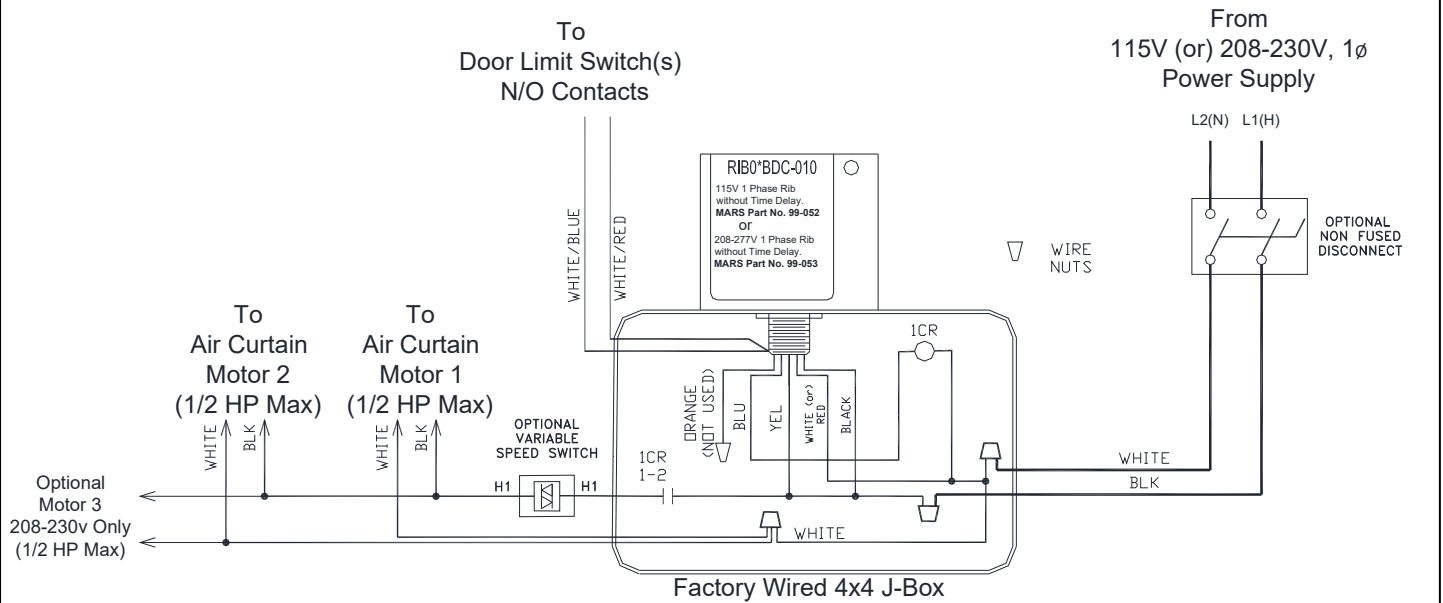

RIB Kit Part Numbers:

- 115v/1 ϕ
- [J0705](#), [J0722](#), [J0726](#)
- 208-230v/1 ϕ
- [J0706](#), [J0723](#), [J0727](#)

Note:

The controllers are wired the same, but are not interchangeable.

RIB, 1 HP with Time Delay and 2 Speed Switch

RIB Kit Rating:

- 115v or 208-230v
- 1 HP Max (1.5HP for 208-230v)
- Adjustable Time Delay
- Two Speed Switch

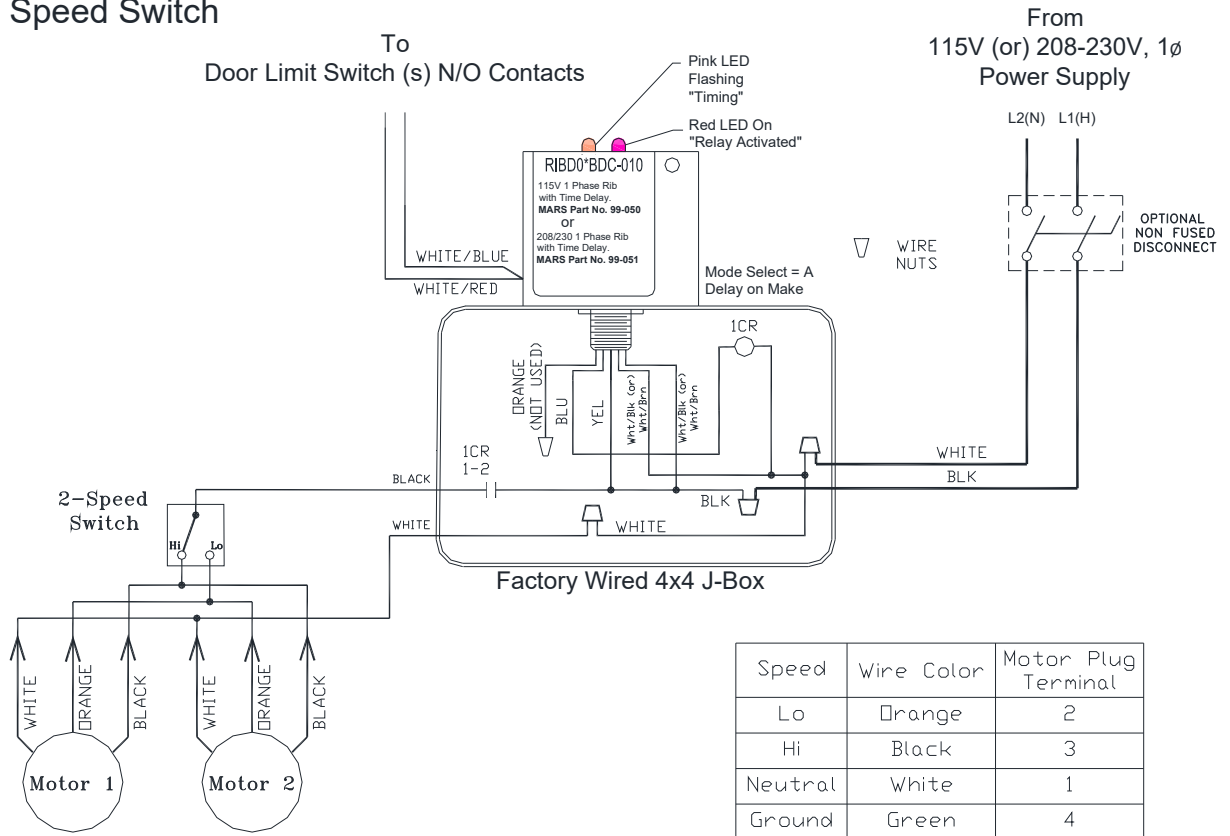

RIB Kit Part Numbers:

- 115v/1φ
 - [J0703](#), [J0708](#), [J0720](#), [J0724](#)
- 208-230v/1φ
 - [J0704](#), [J0709](#), [J0721](#), [J0725](#)

Note:

The controllers are wired the same, but are not interchangeable.

RIB ½ Hp with Two Door Switches

RIB Kit Rating:

- 115v or 208-230v
- 1/2 HP Max
- Two Door Switches

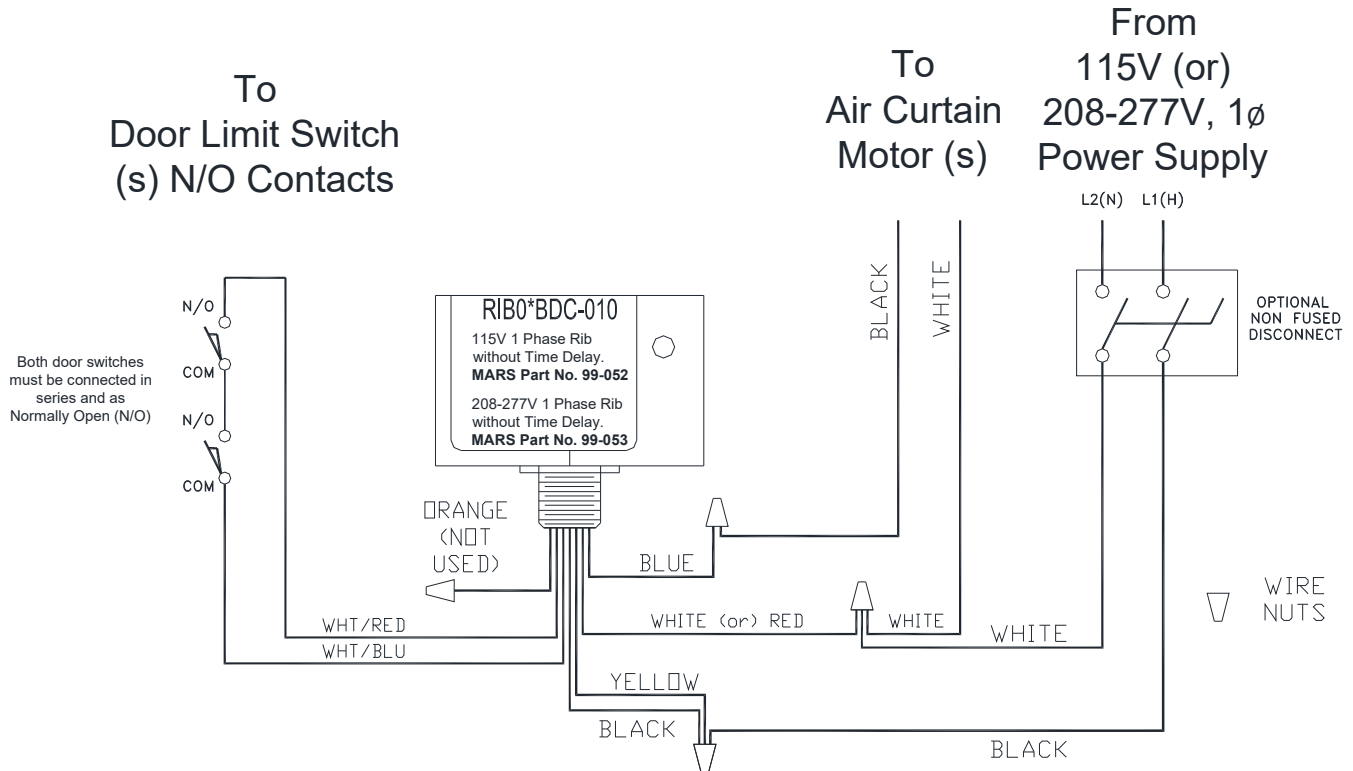

RIB Kit Part Numbers:

- 115v/1Ø
- **J0023**, J0036, J0100
- 208-230v/1Ø
- **J0024**, J0037, J0104

Note:
 The controllers are wired the same, but are not interchangeable.

Typical Motor Control Panel (MCPA-1UA)

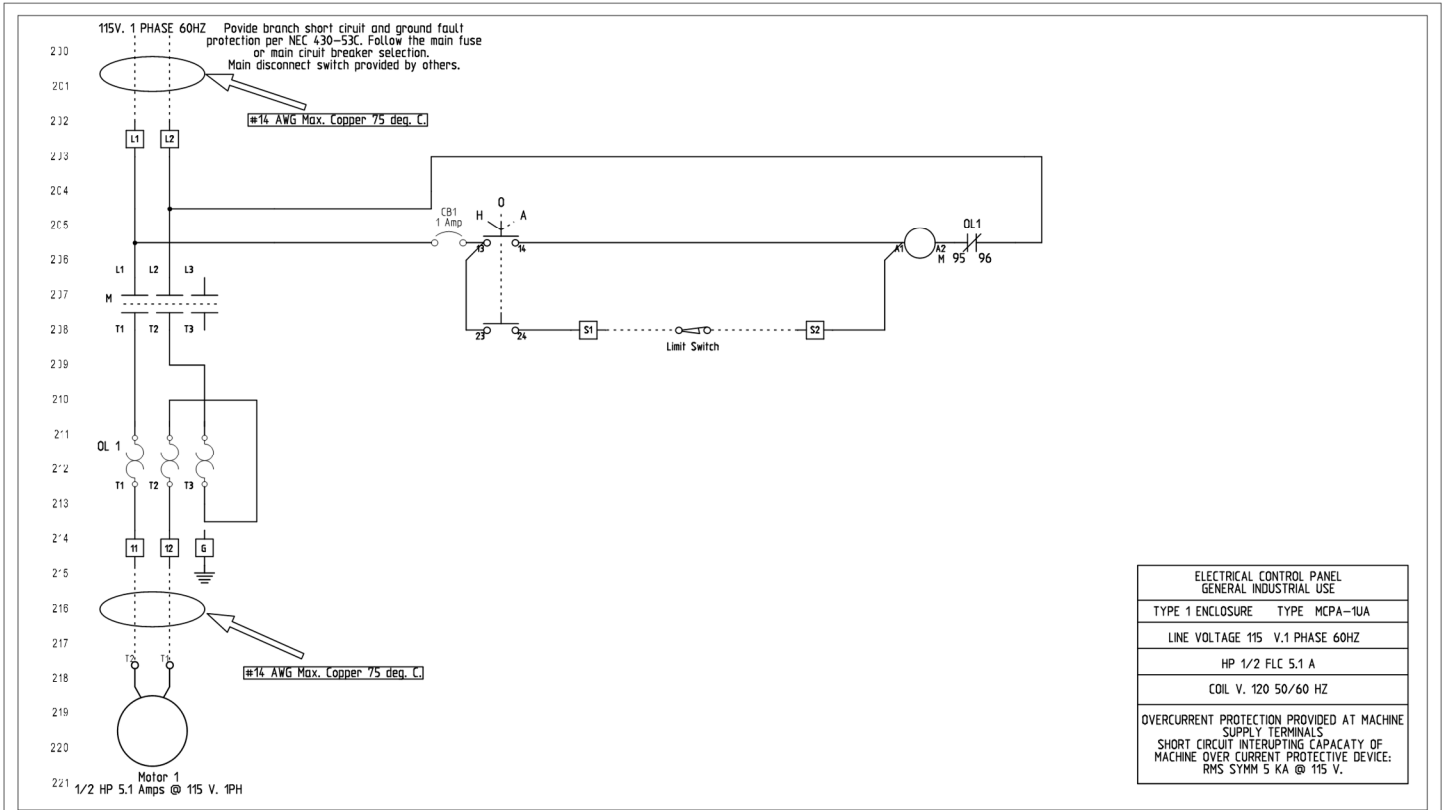

ELECTRICAL CONTROL PANEL GENERAL INDUSTRIAL USE	
TYPE 1 ENCLOSURE	TYPE MCPA-1UA
LINE VOLTAGE 115 V.1 PHASE 60HZ	
HP 1/2 FLC 5.1 A	
COIL V. 120 50/60 HZ	
OVERCURRENT PROTECTION PROVIDED AT MACHINE SUPPLY TERMINALS SHORT CIRCUIT INTERRUPTING CAPACITY OF MACHINE OVER CURRENT PROTECTIVE DEVICE: RMS SYMM 5 KA @ 115 V.	

Modification #	Modification Description
Modification #1	
Modification #2	
Modification #3	

MCPA-1UA
mars

Document Number	Sheet: 2 of 2	Rev. Date: 3/16/2015 1:24:30 PM	Rev.:
		Cre. Date: 3/16/2015	
		Sheet Created by	

Typical Motor Control Panel with Time Delay and Three Speed (MCPA-1UA-TD-3S)

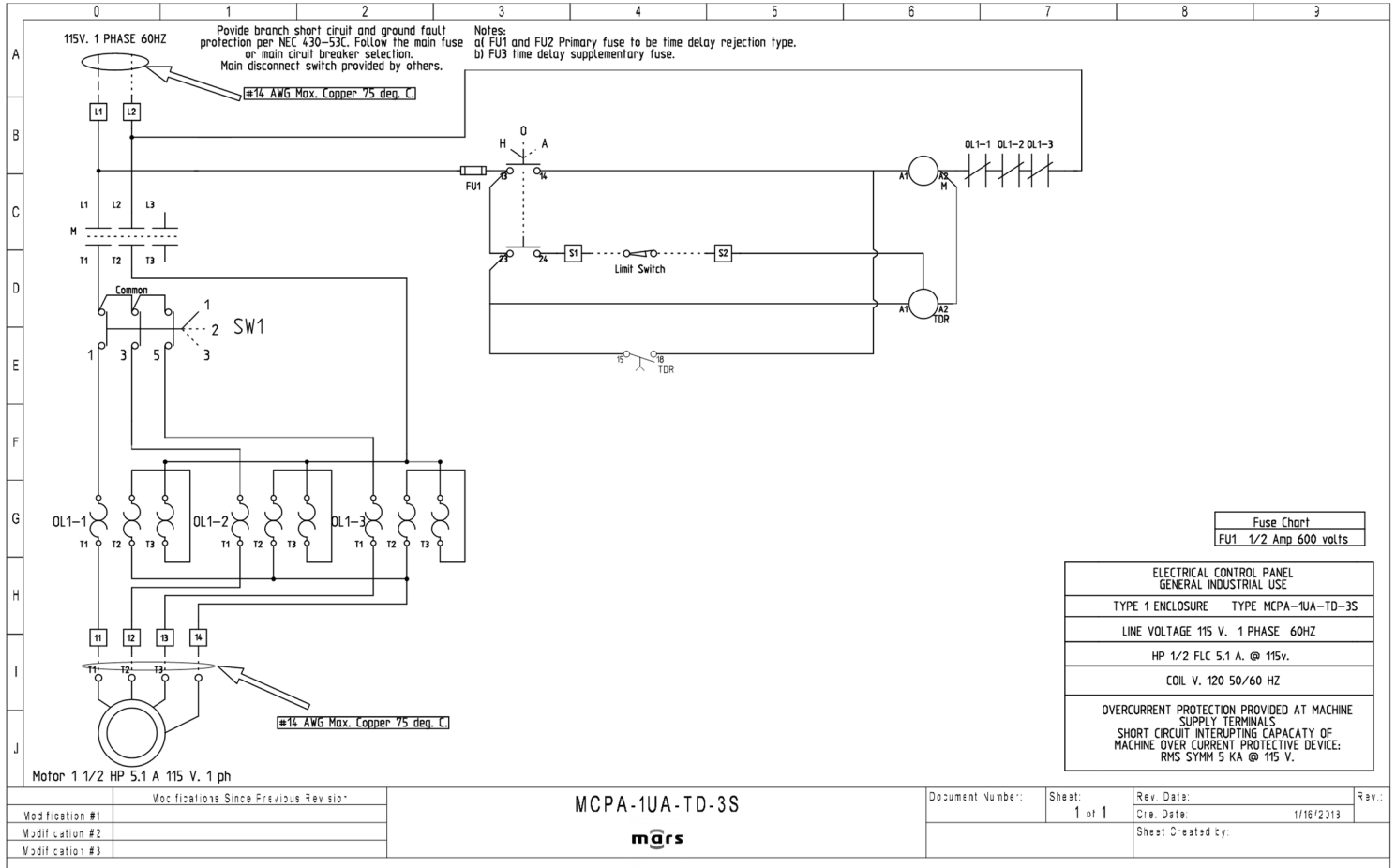

Typical Motor Control Panel with BMS Monitor & Control (MCPA-3UH-303)

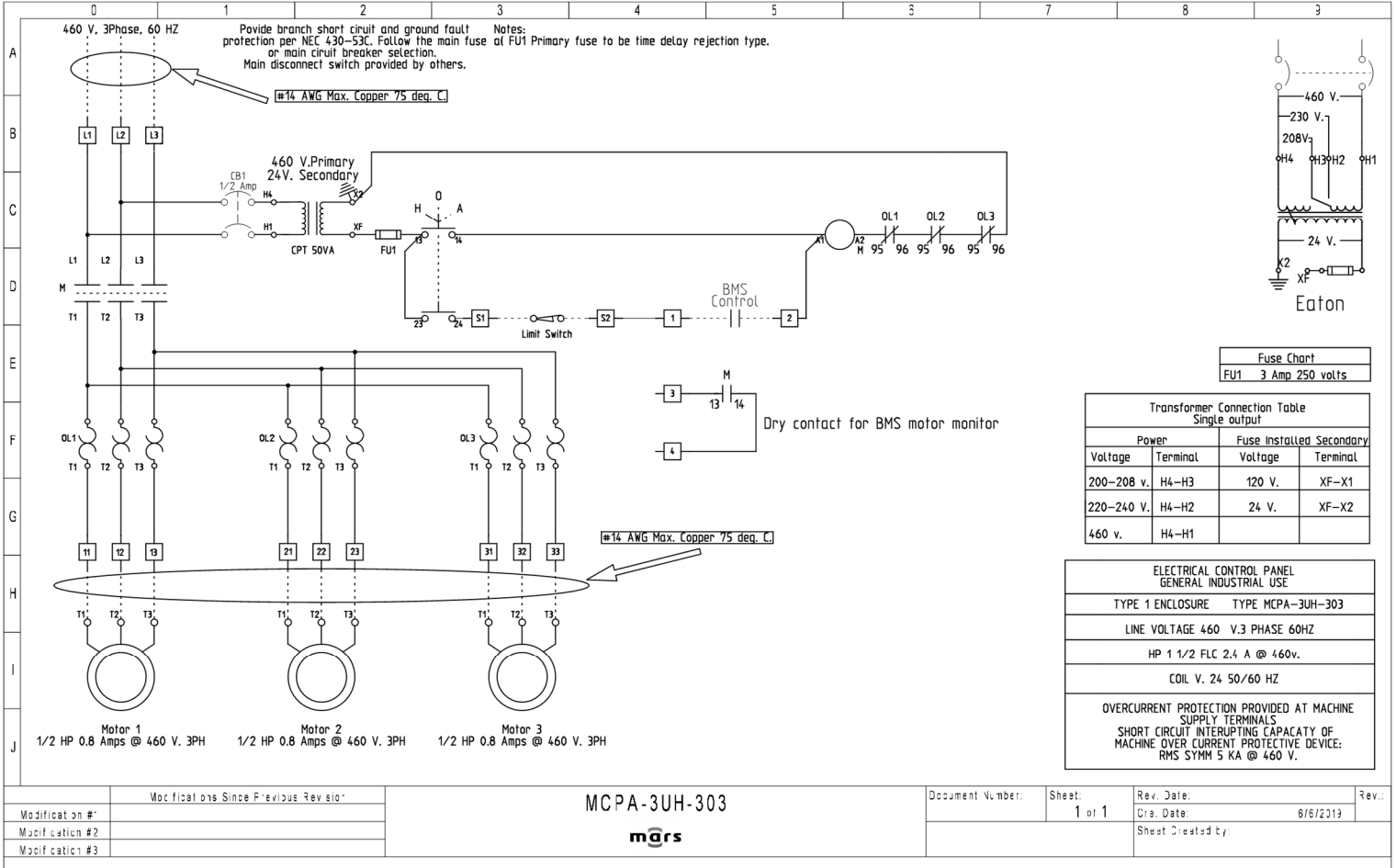

MCPA-3UH-303



Document Number: Sheet: 1 of 1 Rev. Date: 6/6/2013 Rev. Date: 6/6/2013 Sheet Created by:

SimpleLink 2 Controller with TRIAC for LPV2 (MCPS-1UA-SK2)

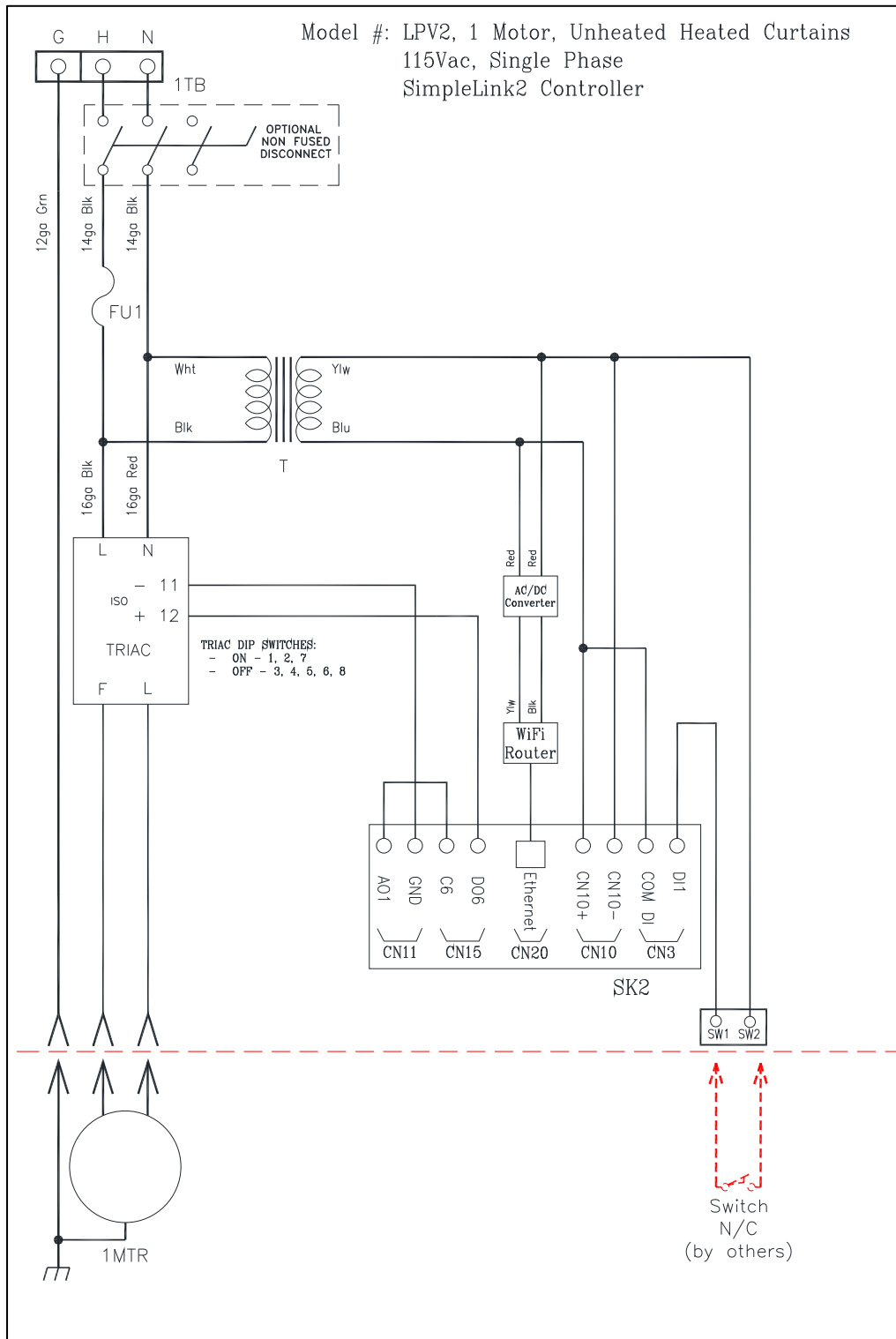

SimpleLink 2 Controller with Remote VFD for STD2 (MCPA-2UG-SK2-VR)

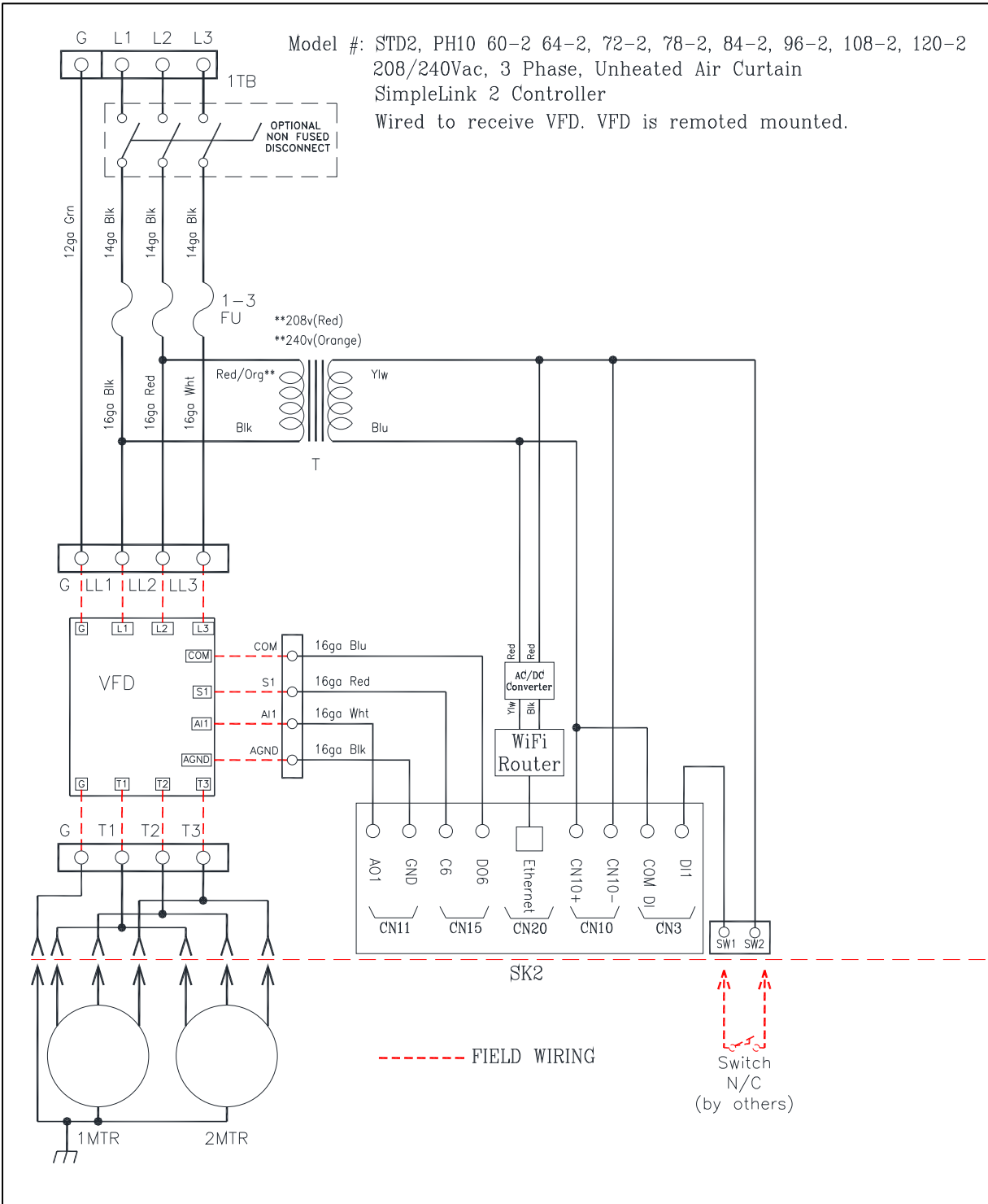

Typical HW/S Heated (1Ph, 1Hp max)

TYPICAL Hot Water/Steam HEATED DIAGRAMS

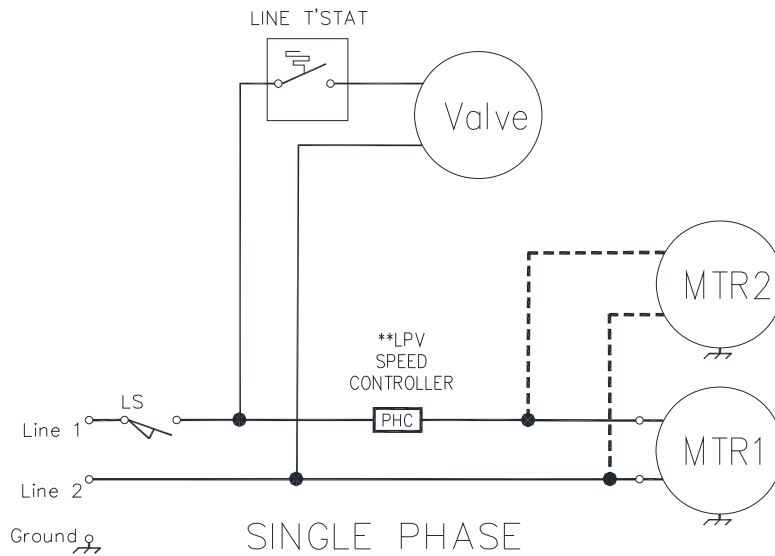

**Speed Controller applicable only for LP series

120/208-240/277v Single Phase Motor

1/6 H.P. Use 15A Micro Switch
 1/2 H.P. Use 15A Micro Switch
 1 H.P. Use 20A Micro Switch

120/208-240/277v Single Phase Motor

Larger than 1 H.P. Use Contactor and
 15A Micro Switch

Typical Single Phase Motor Terminal Connections:

For 1/2 HP: <1> is Common for 115V

<1> is Hot for 208/230V

<2> is Low Speed

<3> is High Speed

<4> is Ground

<5> is Medium Speed

For 1 HP: <1> is Common for 115V, 208/230V

<2> is High Speed

<3> is Low Speed

<4> is Ground

Notes: This wiring diagram is applicable for
 Single Phase motors as follows:

LPV2: Up to 3 motors

STD2: Up to 2 motors

HV2: 1 motor

*See Door Limit Switch submittal for
 additional switch info

S Y M B O L S

LS - Micro Switch

M - Contactor or Motor Starter

MC - Contactor Coil

T - Control Transformer

PHC - Speed Controller (LPV series only)

LPV2 HW/S Heated with Heat on Demand (99-064 Thermostat)

AIR CURTAIN LO PRO HOT WATER W/ HEAT ON DEMAND WIRING DIAGRAM

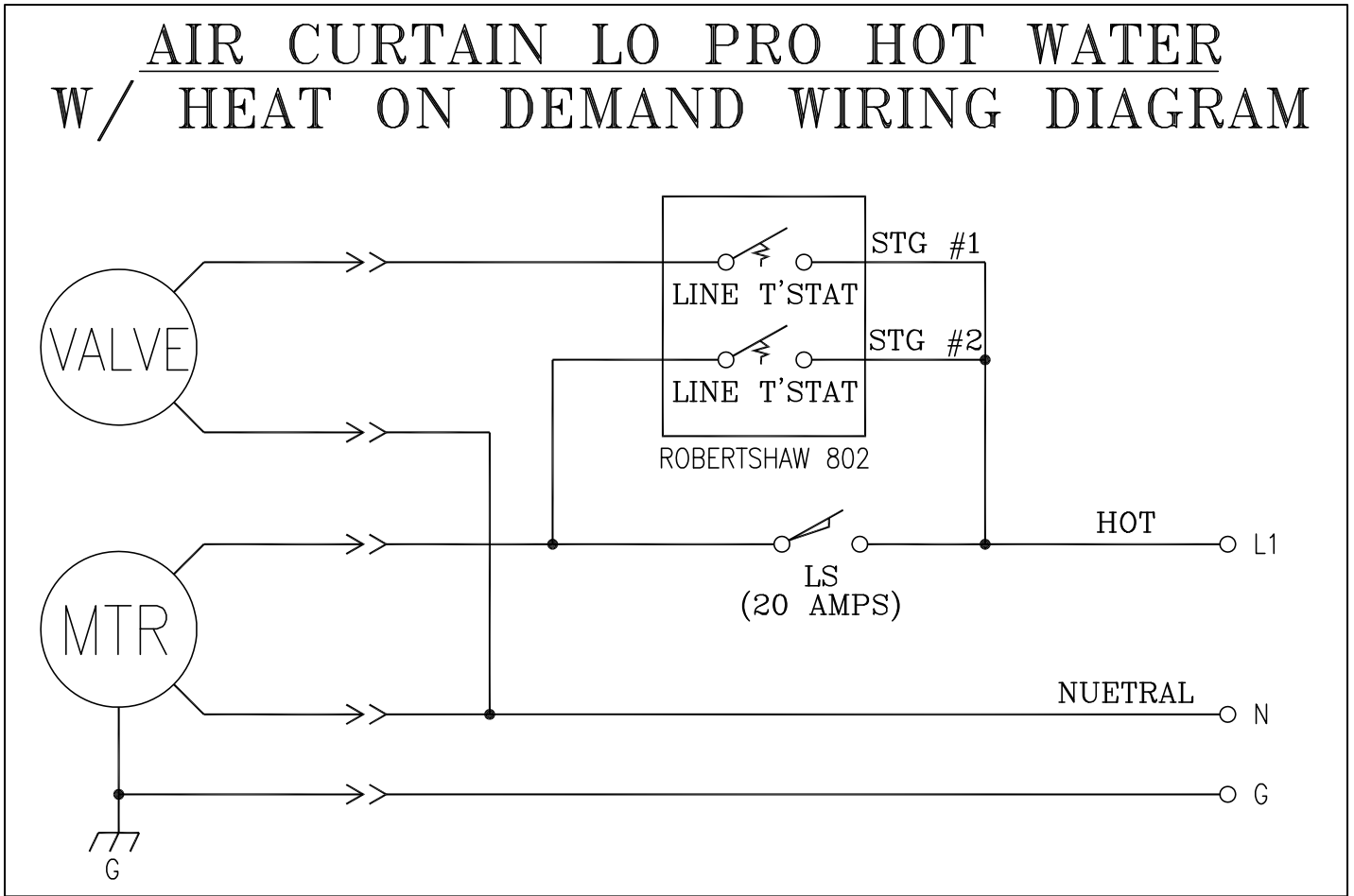

Typical HW/S Heated with RIB

RIB Kit Rating:

- 115v or 208-230v
- 1/2 HP Max
- Adjustable Time Delay
- Hot Water/Steam Heat

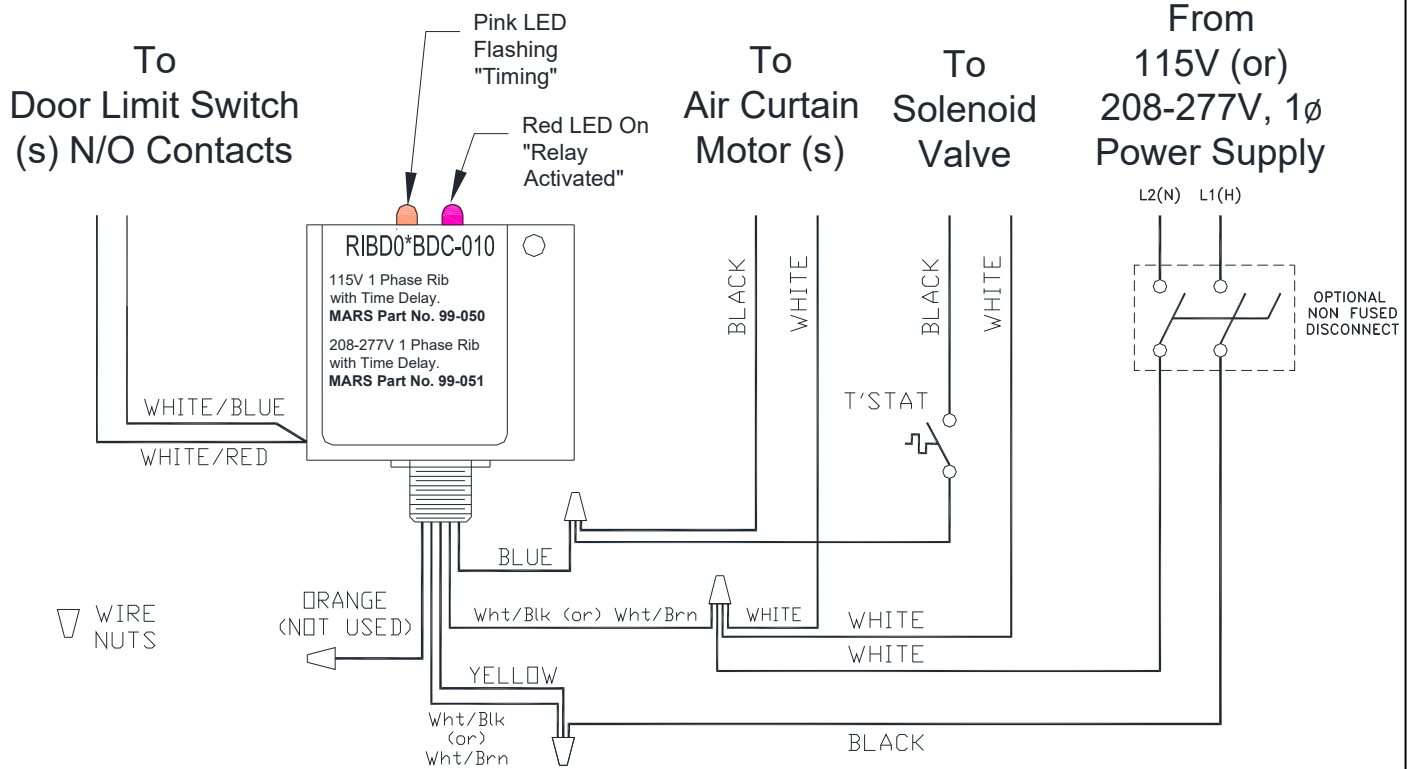

RIB Kit Part Numbers:

- 115v/1Ø
- **J0021, J0028, J0038, J0102**
- 208-230v/1Ø
- **J0022, J0029, J0042, J0106**

Note:
 The controllers are wired the same, but are not interchangeable.

HW/S Motor Control Panel (MCPB-2VD, 1 Hp, 2 Mtr, 208/230v/1ph/60Hz)

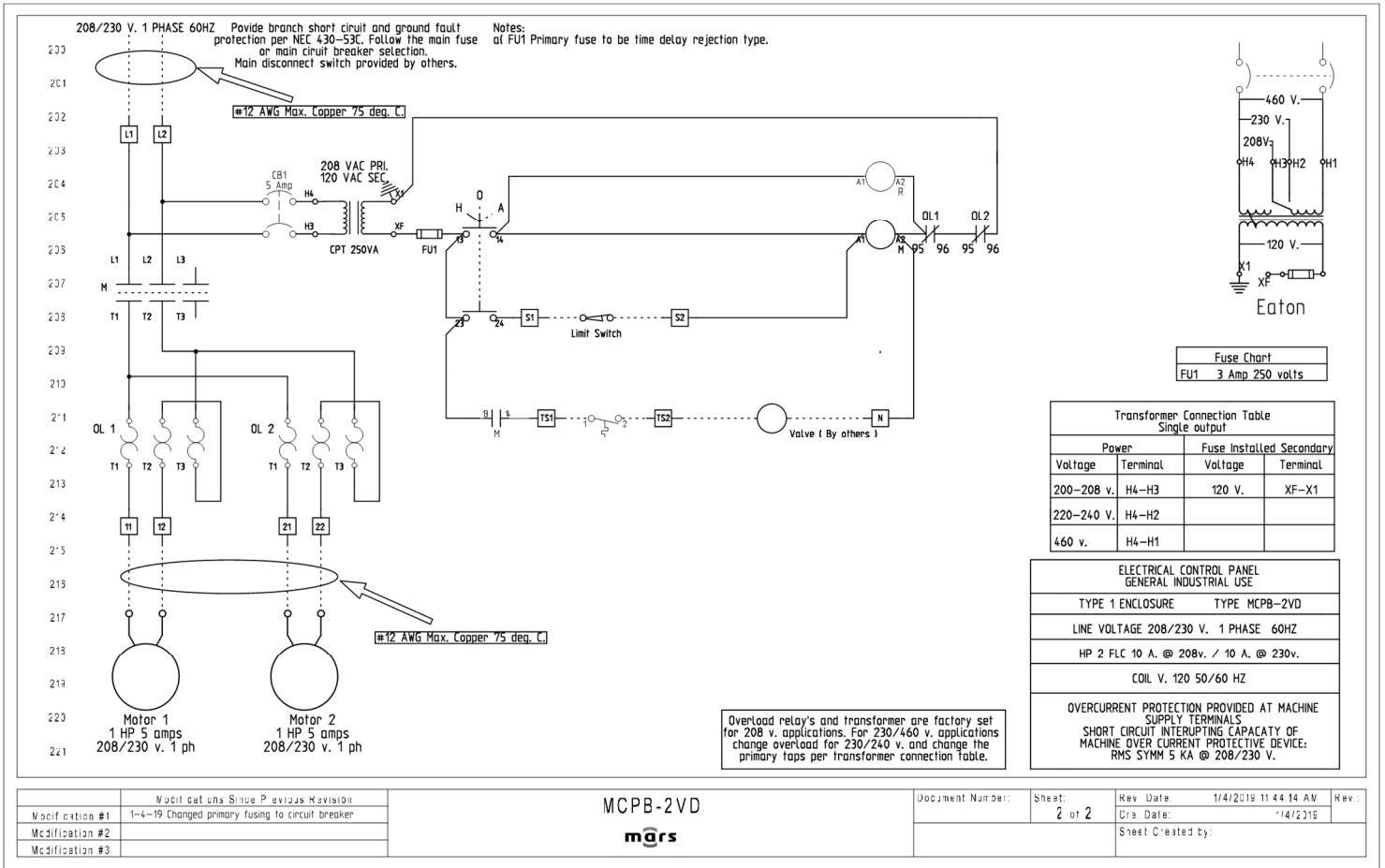

HW/S Motor Control Panel with Heat on Demand (MCPB-2VD-HD, 1Hp, 2 Mtr, 208/230v, 1ph, 60Hz, Heat on Demand with 2 pole Tstat)

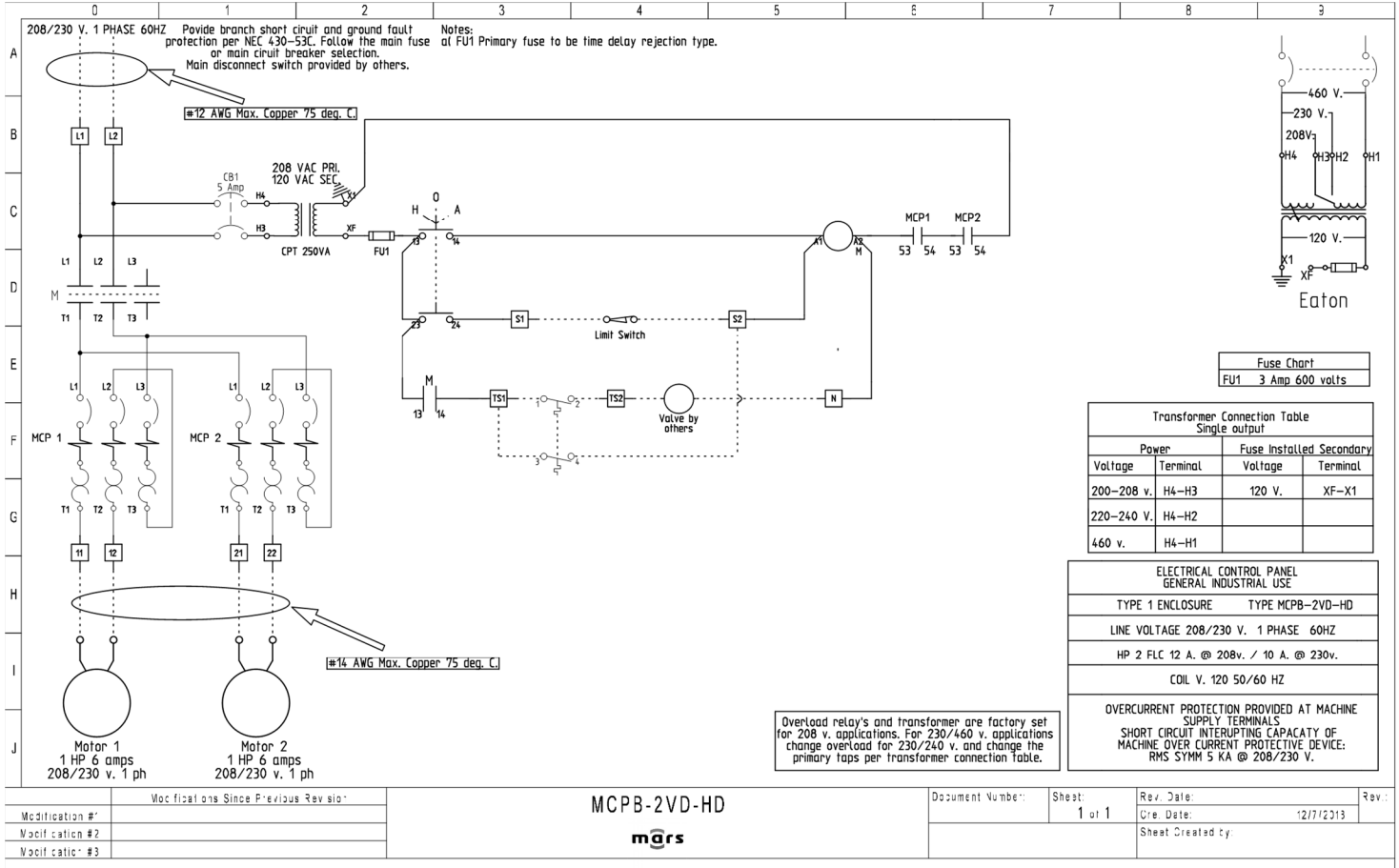

HW/S Motor Control Panel with BMS Monitor & Control (MCPB-3VH-306, 1 Hp, 3 Mtr, 460v, 3ph)

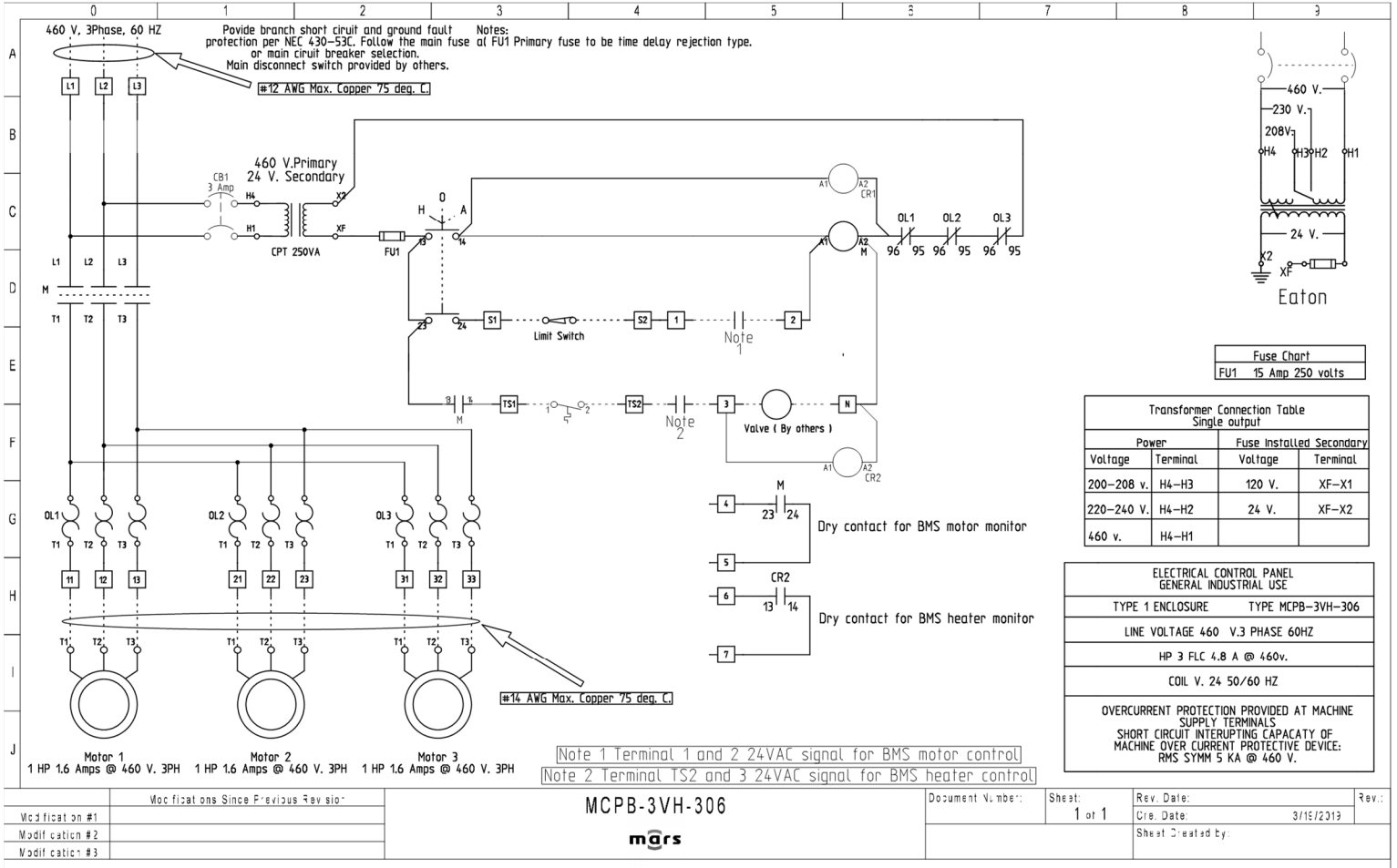

Modification #	Modification Description
Modifcation #1	
Modifcation #2	
Modifcation #3	

MCPB-3VH-306
mars

Document No.:	Sheet: 1 of 1	Rev. Date:	Rev.:
		Cre. Date:	3/15/2313
		Sheet Created by:	

Electric Heated LPV2, 1 Mtr, 460v/3ph Heater, 115v/1ph Motor

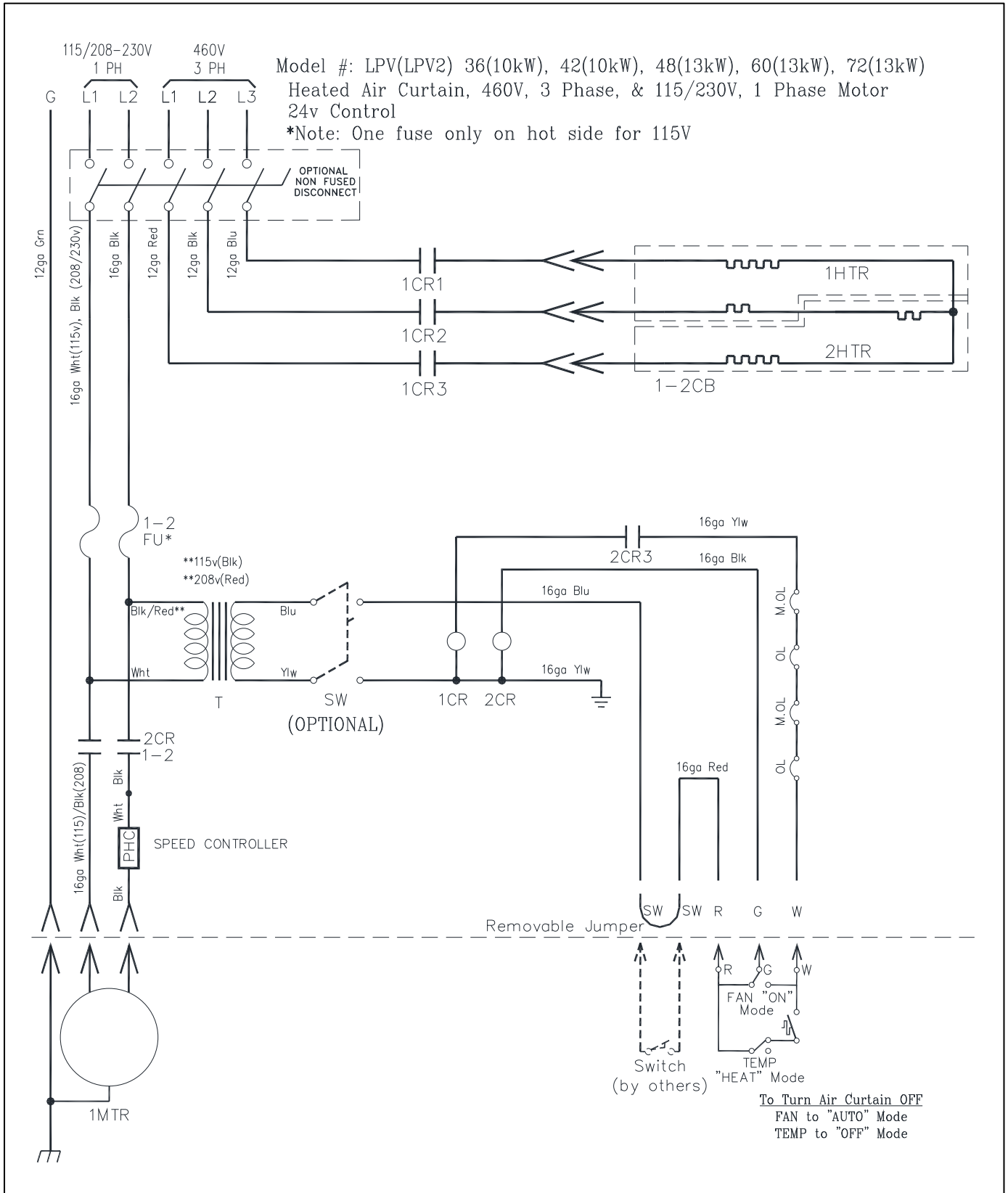

Electric Heated LPV2, 1 Mtr, 460v/3ph Heater, 115v/1ph Motor, SimpleLink Controller

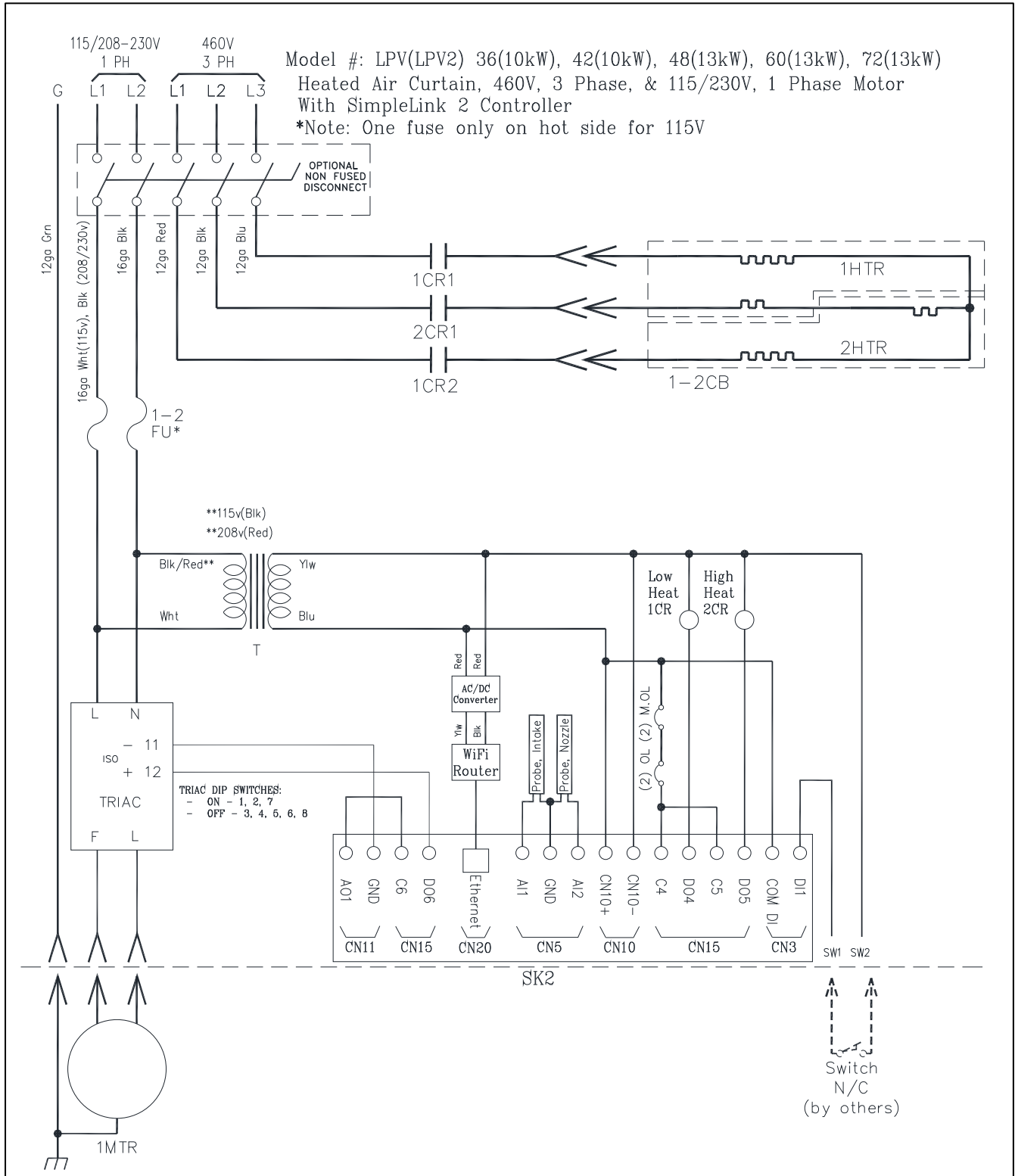

Electric Heated STD2, 2 Mtr, 460v, 3ph, Time Delay

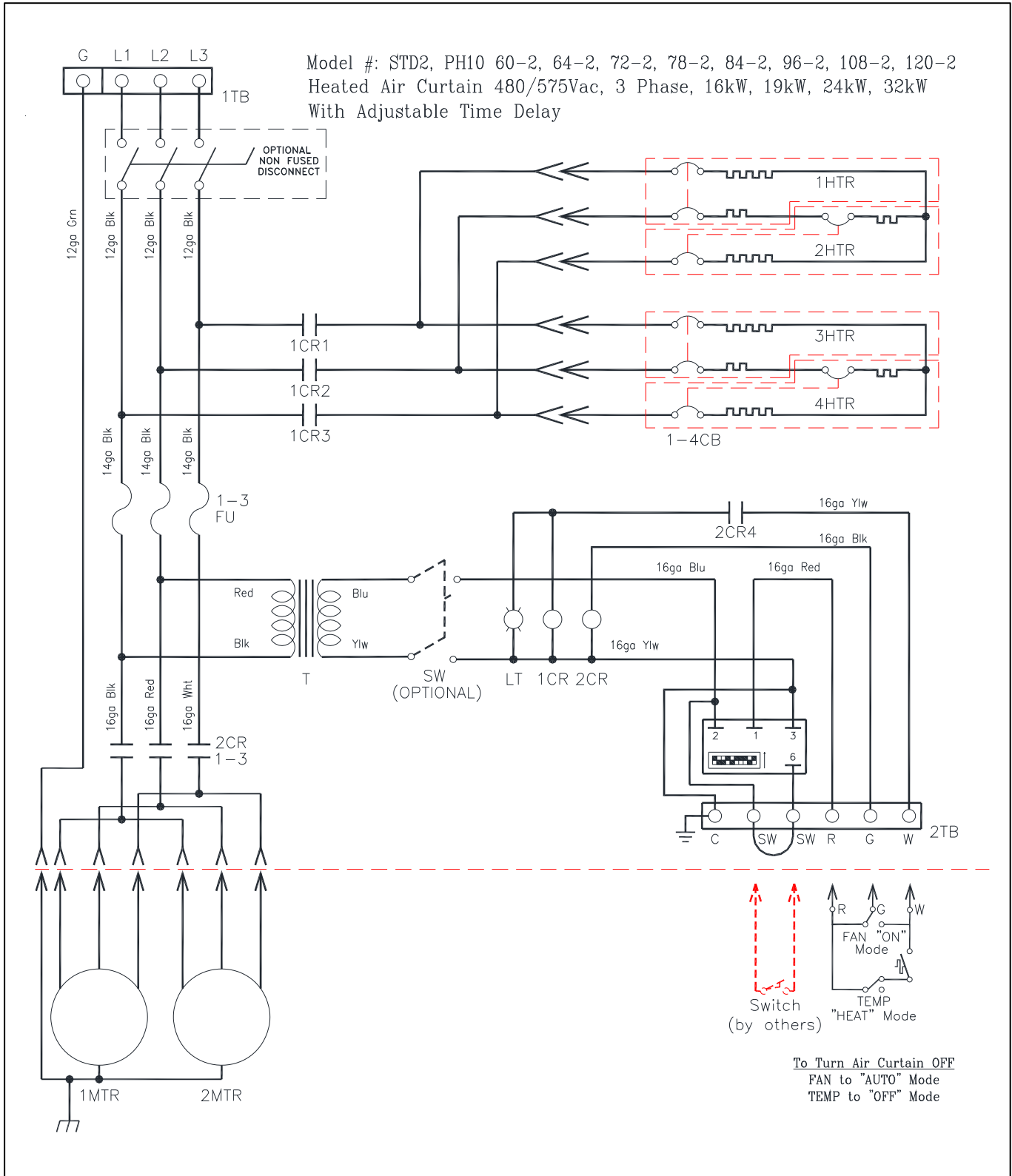

Electric Heated STD2, 2 Mtr, 460v, 3ph, SimpleLink 2 Controller

