

Parts List			
ITEM	PART NO.	DESCRIPTION	QTY
1	189274	WRAP, STAND	1
2	189275	WRAP, STAND SIDE	2
3	189276	BRACKET, REAR LEFT	1
4	189277	BRACK. REAR RIGHT	1
5	189278	BRACKET, FRONT RIGHT	1
6	189279	BRACKET, FRONT LEFT	1
7	189693	WRAP, STAND FRONT W/ C/O	1
8	500183	NUTSERT, 1/4-20 STEWART	8
9	502122	SCR: #10 -24 X .375"(TAPTITE)TRS PH S	20
10	502566	SCR:1/4 -20 X .375"(M)TRS PH S	8

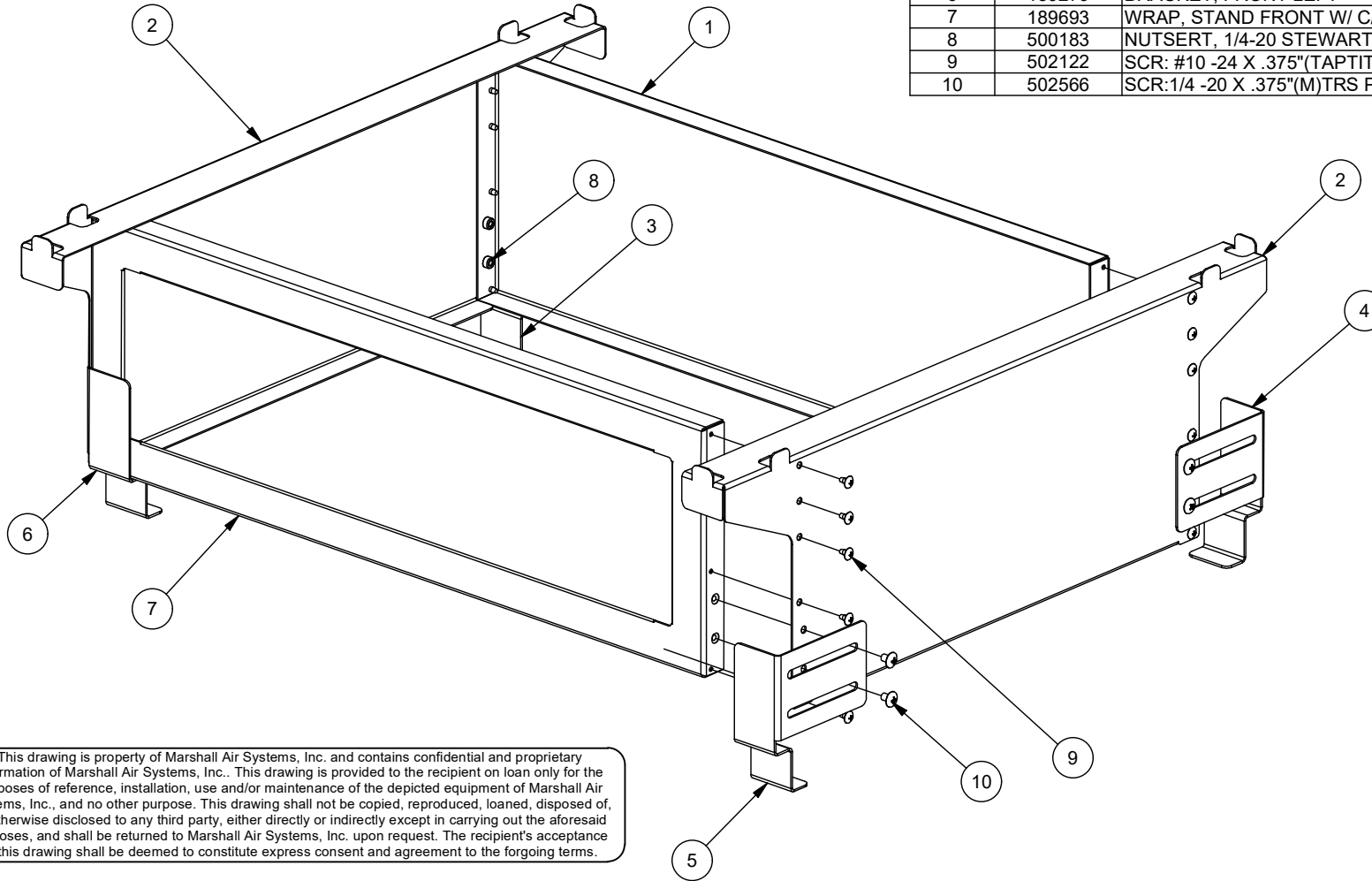

This drawing is property of Marshall Air Systems, Inc. and contains confidential and proprietary information of Marshall Air Systems, Inc.. This drawing is provided to the recipient on loan only for the purposes of reference, installation, use and/or maintenance of the depicted equipment of Marshall Air Systems, Inc., and no other purpose. This drawing shall not be copied, reproduced, loaned, disposed of, or otherwise disclosed to any third party, either directly or indirectly except in carrying out the aforesaid purposes, and shall be returned to Marshall Air Systems, Inc. upon request. The recipient's acceptance of this drawing shall be deemed to constitute express consent and agreement to the forgoing terms.

REVISION HISTORY				DRAWN BY: MT	DATE: 3/28/2022	<b>MARSHALL AIR SYSTEMS, INC.</b>					
REV	DESCRIPTION	DATE	BY	GENERIC NAME: STAND						<b>STAND, ASBY FOR DH5D2-6BAC</b>	
				PRODUCT LINE: FAB	PRODUCT CLASS: HHC						
				MATERIAL: REFERENCE		SIZE: A	ROUTING: ASBY	DWG. NO.: 189694	REV.: 0		
				X		SCALE: 1:6	IMAGE MAY BE REDUCED NTS	CODE: BM184911			