



EASY CHEESER™ - MOZZARELLA SLICER
55300A-516D

OPERATING AND MAINTENANCE INSTRUCTIONS

IMPORTANT

1. To get the best operation and life from your machine, please read and comply with these instructions.
2. Clean machine thoroughly before and after each use using cleaning instructions below.
3. Minimize the use of alkaline cleaners as they may cause pitting and dulling of the finish.

OPERATION

1. Set unit on a flat, sturdy surface when cutting cheese.
2. Prepare the block of cheese to be cut. Since cheese is produced in different sized loaves, the size of the prepared block must be convenient to the preparer. The EASY CHEESER™ will easily handle 1/3 of many 5 pound loaves.
3. Raise the CUTTING BOW ASSEMBLY to the full upward position and place the prepared cheese block against the guide at the right of the SUPPORT BLOCK ASSEMBLY. **NOTE:** We recommend that the longest dimension of the prepared block be pointed toward the CUTTING BOW WIRES for the first and second cuts when it can be done to produce the desired size and shapes of cheese.
4. Gently and steadily, press the CUTTING BOW through the prepared cheese block. This has now produced slices of cheese.
5. To cut sticks of cheese, set the sliced block of cheese aside and again raise the CUTTING BOW ASSEMBLY. (Change the CUTTING BOW ASSEMBLY if it is desired to cut rectangular sticks rather than square sticks.) Turn the sliced block ¼ turn (90 degrees) and again place the block on the SUPPORT BLOCK ASSEMBLY in the same position as in line number (3) above. Gently and steadily press the CUTTING BOW through the sliced block. This has now produced sticks of cheese.
6. To cut cubes– set the “sticked” block of cheese aside and again raise the CUTTING BOW. Place the “sticked” block on the SUPPORT BLOCK ASSEMBLY so that the sticks lie across the slots in the frame. Be sure the “sticked” block is against the guide at the right end of the FRAME to get uniform cuts. Gently and steadily, press the CUTTING BOW through the “sticked” block. This has produced cubes.
7. If unit fails to operate properly when first used call NEMCO customer service at 1-800-782-6761.

IMPORTANT:

Store in a place to protect the EASY CHEESER from being bumped. Accidental notches in the wires may cause premature failure.

CLEANING

NOTE: Proper maintenance plays an important part in the life span and functioning of the unit.

1. For easiest cleaning, wash the unit soon after each use to prevent cheese from hardening prior to washing.
2. Wash with a pressure spray or conventional sink cleaning methods. It is dishwasher safe but strong alkaline cleaners will dull the surface and eventually pit the metal. **MINIMIZE THE USE ALKALINE CLEANERS.**
3. Remove the PIVOT PIN ASSEMBLY and release the CUTTING BOW.
4. Wash the PIVOT PIN ASSEMBLY and the FRAME and V-BLOCK ASSEMBLY by conventional methods. Notice that the V-BLOCK ASSEMBLY may be removed from the FRAME for cleaning by removing screws and then can be disassembled. When reassembling the unit, be sure parts are aligned.
5. Wash the CUTTING BOW by either of the following methods, as deemed necessary.
 - a) **With the cutting wire installed** wash thoroughly by conventional methods. Pay particular attention to where the wire wraps around the posts and screws. A BRUSH is provided for cleaning in this area.
 - b) **To wash with cutting wire removed**, remove the CUTTING WIRE by loosening SCREWS to fully expose the posts and screws. Wash thoroughly with the BRUSH provided. New wire must be installed to achieve necessary tension. Notice that the POSTS can be removed for cleaning by removing the screws. Be sure the screws are tight when the CUTTING BOW is reassembled.

SERVICE INSTRUCTIONS

TO CHANGE CUTTING BOWS

1. Release CUTTING BOW by pulling the knob on the PIVOT PIN ASSEMBLY.
2. Position the alternate CUTTING BOW on the FRAME and SUPPORT ASSEMBLY so that the PIVOT PIN holes are aligned and insert the PIVOT PIN ASSEMBLY from either side of the FRAME.

TO REPLACE CUTTING WIRE

The REPLACEMENT WIRE KIT contains REPLACEMENT WIRE, a TENSIONER, spare SCREWS and complete instructions for easy re-wiring of the CUTTING BOW.

If you prefer, the CUTTING BOW can be returned to NEMCO for wire replacement.

EXPLODED PARTS DIAGRAM:

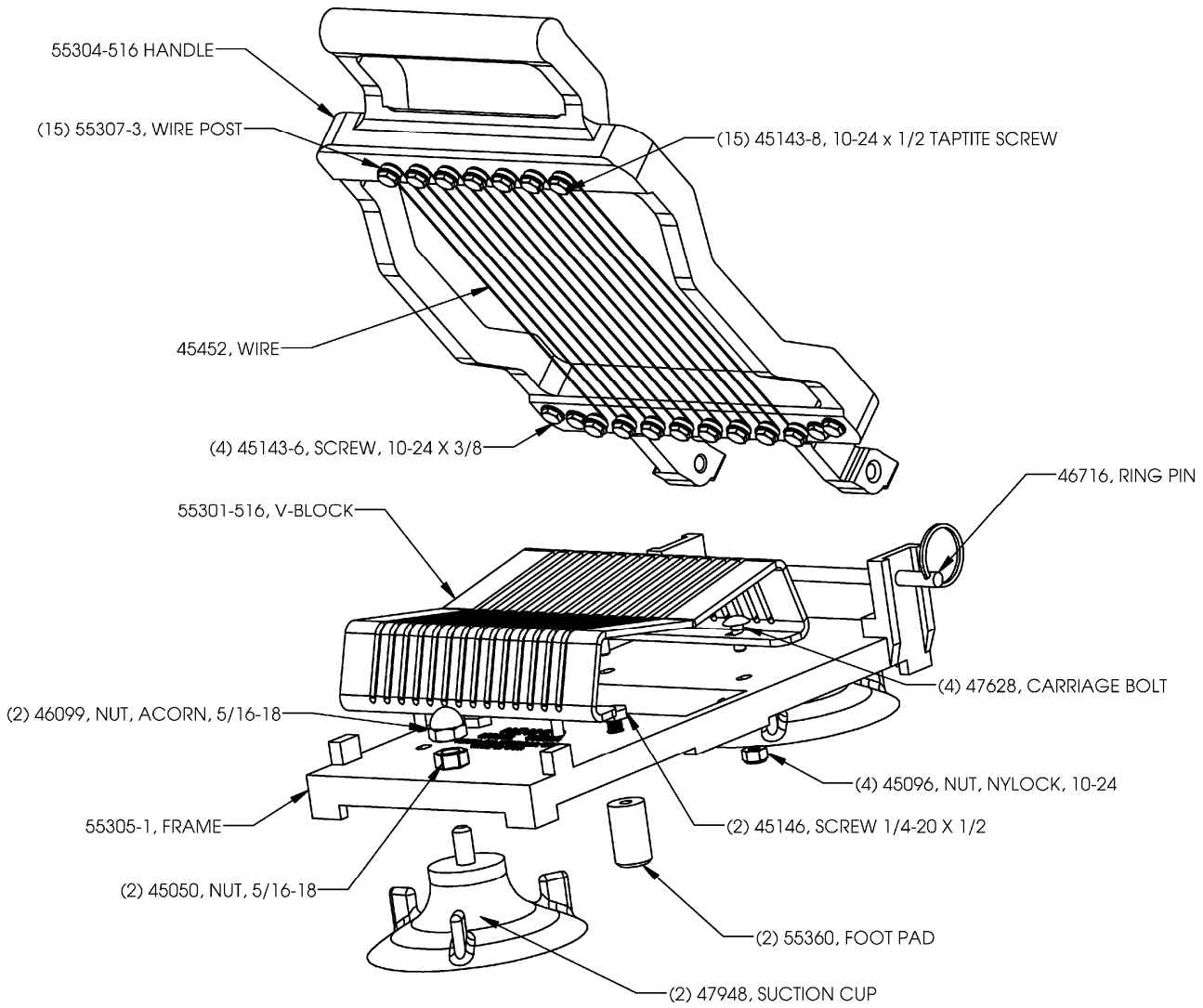

NEMCO FOOD EQUIPMENT 301 Meuse Argonne, Hicksville, OH 43526
 1-800-782-6761 Toll Free 419-542-6690 Fax
www.nemcofoodequip.com

46018-1
 4/13/11