



FOOD EQUIPMENT

Operating and Maintenance Instructions

Model: **6152-24** Bar Heater On A Stand

INTRODUCTION

1. Please read instructions before using this appliance.
2. When using electrical appliances, basic precautions should always be followed to reduce the risk of fire, electric shock and injury.
3. Clean machine thoroughly before and after all uses following cleaning instructions below.

ELECTRICAL REQUIREMENTS

1. Plug warmer into a grounded outlet with correct voltage and sufficient power capacity. Refer to the product label (serial plate) on the warmer for voltage and wattage requirements.

SAFETY INSTRUCTIONS

1. **Warning!** All power must be disconnected at power source before any service procedure is performed.
2. This appliance is hot when in use. To avoid burns, do not let bare skin touch hot surfaces. Keep combustible materials, such as drapes and other furnishings, away from appliance.
3. Extreme caution is necessary when any appliance is used by or near children and whenever the appliance is left unattended.
4. Always unplug appliance when not in use and before cleaning, adjusting or maintaining this machine. To disconnect appliance, turn controls off and remove plug from power source.
5. Do not operate any appliance with a damaged cord or plug, after the appliance malfunctions, has been dropped, or damaged. Return appliance to an authorized service facility for examination, electrical or mechanical adjustment, or repair.
6. Do not use outdoors. This appliance is not intended for use in wet or moist locations. Never locate appliance where it may fall into water.
7. Connect to properly grounded outlets only. Avoid the use of extension cords. Do not run cord under carpeting, runners, or the like. Arrange cord away from traffic area and where it will not be tripped over.
8. This appliance is equipped with a power cord with a three-blade plug. Plug ONLY into a matching three-blade outlet. DO NOT cut or break off the third blade or attempt to use with a two-blade extension cord.
9. To prevent a possible fire, it is recommended that the unit is placed on a non-combustible surface.
10. This appliance has electrical parts. Do not use it in areas where gasoline, paint, or flammable liquids are used or stored.

INSTALLATION

1. Place warmer on Base and tighten Thumb Screw.
2. Set warmer on a flat, stable surface near the power source.
3. This unit radiates heat when in use therefore we recommend that the unit be placed on a non-combustible surface.
4. If warmer fails to work properly when first operated call NEMCO customer service at 1-800-782-6761.

OPERATION

1. Place food products in a pan located directly under the warmer for best results.
2. Turn warmer off and remove plug from power source when not in use.

CLEANING

NOTE: Proper maintenance plays an important part in the life span and functioning of the warmer.

1. Unplug the power cord before cleaning.
2. Do not immerse in water or other liquid. Avoid splashing water into unit.
3. The housing and reflectors are made of anodized aluminum and aluminized steel, which can be kept clean by use of a damp sponge and soap solution.

TROUBLESHOOTING

No Heat	Check that power switch is turned "ON".
	Check power at heater.
Unit Blows Fuse or Circuit Breaker	Check to make sure circuit is not overloaded.

Service Part List

Model: 6152-24 Bar Heater On A Stand

PARTS DRAWING AND WIRING DIAGRAMS FOR 6152-24 BAR HEATERS

NOTE: BAR WARMER IS DRAWN UPSIDE DOWN

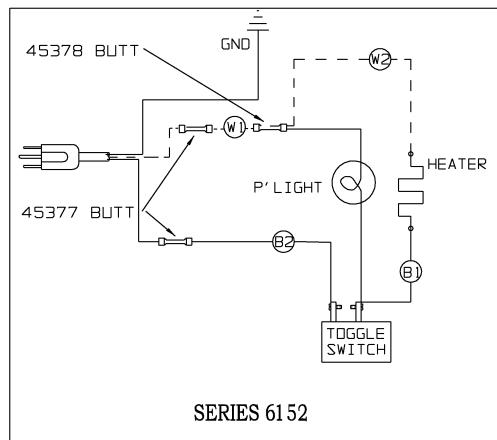
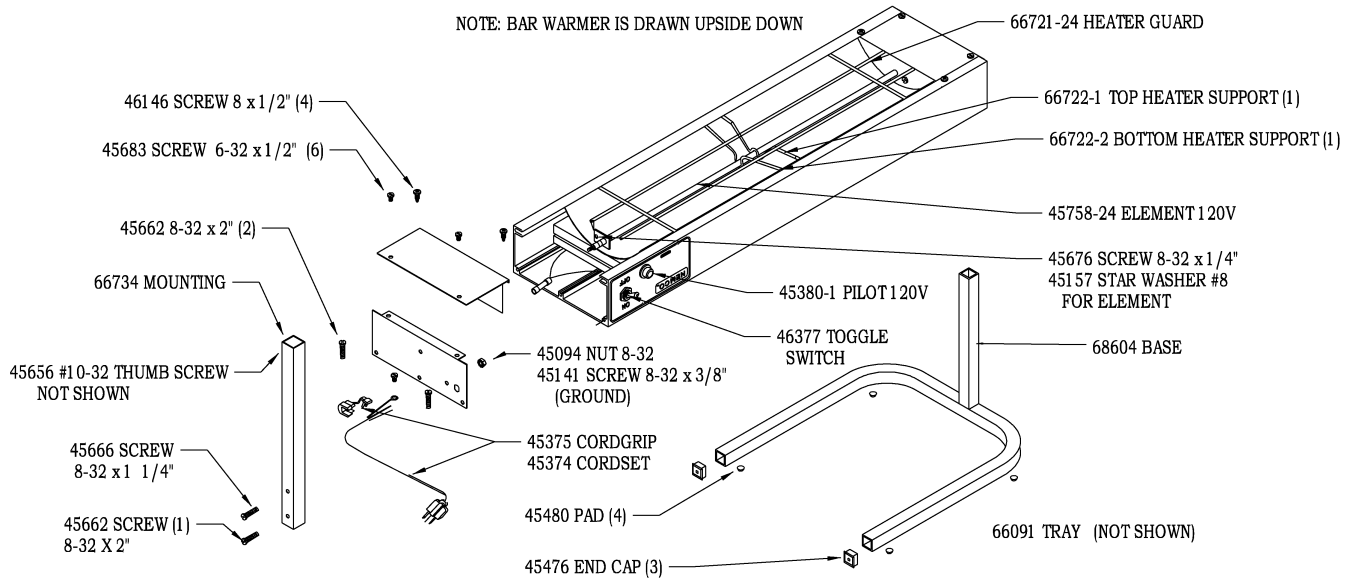

WIRE SCHEMATIC



NEMCO FOOD EQUIPMENT 301 Meuse Argonne, Hicksville, OH 43526
 Phone: (419) 542-7751 Fax: (419) 542-6690 Toll free: 1-800-782-6761
www.nemcofoodequip.com

