

Popper Model

GS1508

USER MANUAL



GS1508







Table of Contents



SAFETY PRECAUTIONS	3
INSTALLATION INSTRUCTIONS	5
Inspection of Shipment	5
Manual	5
Items Included with this Unit	5
Setup	6
Electrical Requirements	7
Before You Plug In Machine	7
OPERATING INSTRUCTIONS	8
Controls and Their Functions	8
Popping Corn Instructions	9
Care and Cleaning	10
Daily Kettle Cleaning Instructions	10
Daily Unit Cleaning Instructions	11
Troubleshooting	12
AGITATOR SET COLLAR ADJUSTMENT	13
MAINTENANCE INSTRUCTIONS	14
ORDERING SPARE PARTS	15
Replacing Broken Glass	16
Cabinet Exterior – Rear View	17
Wiring Diagram	18
Model No. GS1508	18
PRODUCT WARRANTY	19
PRODUCT SERVICE	19
TERMS & CONDITIONS	19



SAFETY PRECAUTIONS



	 DANGER
	<p>Machine must be properly grounded to prevent electrical shock to personnel. Failure to do so could result in serious injury, or death. DO NOT immerse any part of this equipment in water. DO NOT use excessive water when cleaning. Keep cord and plug off the ground and away from moisture. Always unplug the equipment before cleaning or servicing. Make sure all machine switches are in the OFF position before plugging the equipment into the receptacle.</p> <p>008_051514</p>



	 DANGER
	<p>Improper installation, adjustment, alteration, service, or maintenance can cause property damage, injury, or death. Any alterations to this equipment will void the warranty and may cause a dangerous condition. This appliance is not intended to be operated by means of an external timer or separate remote-control system. NEVER make alterations to this equipment. Read the Installation, Operating, and Maintenance Instructions thoroughly before installing, servicing, or operating this equipment.</p> <p>014_020416</p>



	 WARNING
	<p>To avoid burns, DO NOT touch the kettle or any heated surface. DO NOT place or leave objects in contact with heated surfaces.</p> <p>013_092414</p>

	 WARNING
	<p>ALWAYS wear safety glasses when servicing this equipment.</p> <p>010_010914</p>

	 WARNING
	<p>No user serviceable parts inside. Refer servicing to qualified service personnel.</p> <p>011_051514</p>

	 WARNING
	<p>Read and understand operator's manual and all other safety instructions before using this equipment. To order copies of the operator's manual go to www.nemcofoodequip.com or call 800.782.6761.</p> <p>022_060215</p>

	 WARNING
	DO NOT allow direct contact of this equipment by the public when used in food service locations. Only personnel trained and experienced in the equipment operation may operate this equipment. Carefully read all instructions before operation. 012_010914

	 WARNING
	This machine is NOT to be operated by minors. 007_010914

INSTALLATION INSTRUCTIONS

Inspection of Shipment

After unpacking, check thoroughly for any damage which may have occurred in shipment. Purchaser should make claim directly to carrier for any damages to merchandise that occur in transit. The warranty does not cover damage that occurs in transit, or damage caused by abuse, or consequential damage due to the operation of this machine, since it is beyond our control (reference warranty in back of manual).

Manual

Read and understand the operator's manual and all other safety instructions before using this equipment. To order copies of the operator's manual contact Global Solutions, 301 Meuse Argonne Hicksville, OH 43526, 800.782.6761, or go to www.nemcofoodequip.com.

Items Included with this Unit

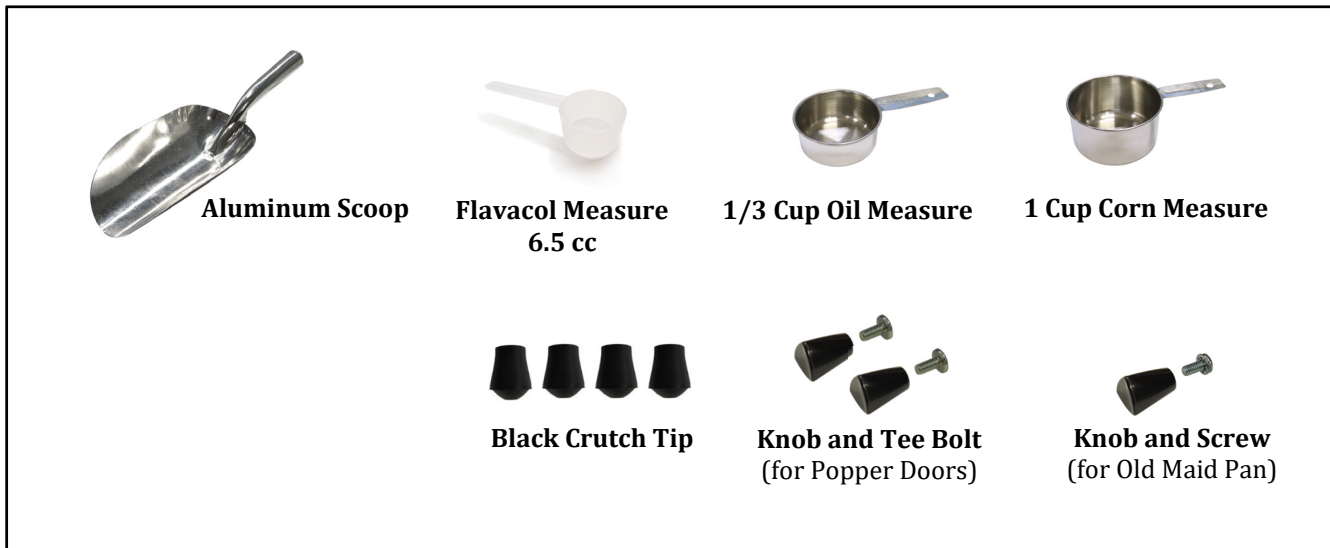

Setup

This unit has been tested at the factory.



1. Remove all packaging and tape prior to operation. Remove accessories and carefully remove kettle packed in cabinet interior.
2. Place unit on a sturdy, level base.
3. Unit has 4 glide feet preinstalled at the factory (see image below). Install a Black Crutch Tip on each foot. Firmly push crutch tip over glide until it covers glide entirely.
4. Tilt kettle and insert into hanger arms, then allow kettle to return naturally to an upright position (see image below).
5. Plug kettle lead into receptacle located on ceiling of cabinet interior. Align keyed or hook shaped prong with the correct opening, then push plug all the way in and twist or rotate to lock in place. To unplug, untwist kettle plug before attempting to pull from receptacle.
6. Door knobs are shipped in accessories pack. Install a door knob with tee bolt on each popper door; install knob with screw on old maid pan.
7. After setup, unit should be cleaned prior to use (see Care and Cleaning section).



Electrical Requirements

The following power supply must be provided:

GS1508: 120 V~, 12.7 A, 1525 W, 60 Hz

	 DANGER
	<p>Machine must be properly grounded to prevent electrical shock to personnel. Failure to do so could result in serious injury, or death. DO NOT immerse any part of this equipment in water. DO NOT use excessive water when cleaning. Keep cord and plug off the ground and away from moisture. Always unplug the equipment before cleaning or servicing. Make sure all machine switches are in the OFF position before plugging the equipment into the receptacle.</p> <p>008 051514</p>

A certified electrician must furnish sufficient power for proper machine operation and install any supplied receptacle. We recommend this equipment be on a dedicated and protected circuit. Failure to wire properly will void the warranty and may result in damage to the machine. It is Global Solutions' recommendation that this machine be plugged directly into a wall outlet. The use of extension cords is not recommended due to safety concerns, and may cause sacrificed and/or reduced performance. Make sure cord is located to prevent a trip hazard or unit upset.

Before You Plug In Machine

1. Make sure all machine switches are OFF before plugging equipment into receptacle.
2. Make sure wall outlet can accept the grounded plugs (where applicable) on the power supply cord.
3. The wall outlet must have the proper polarity. If in doubt, have a competent electrician inspect the outlet and correct if necessary.
4. **DO NOT** use a grounded to un-grounded receptacle adapter (where applicable).
5. Install unit in a level position.

	 CAUTION
	<p>If the supply cord is damaged, it must be replaced by Global Solutions, its service agent or similarly qualified persons in order to avoid a hazard.</p> <p>039 080614</p>

OPERATING INSTRUCTIONS

Controls and Their Functions

KETTLE HEAT SWITCH

Two position, ON/OFF lighted rocker switch - supplies power to the heating element in the kettle. The green switch light ON indicates there is power to the kettle heating element.

KETTLE MOTOR SWITCH

Two position, ON/OFF lighted rocker switch - supplies power to the kettle agitator motor. The Kettle Motor Switch **MUST** be ON at all times when there is popcorn (popped or un-popped) in the kettle.

LIGHTS/WARMER SWITCH

Two position, ON/OFF lighted rocker switch - supplies power to the interior cabinet light and corn pan heat element.

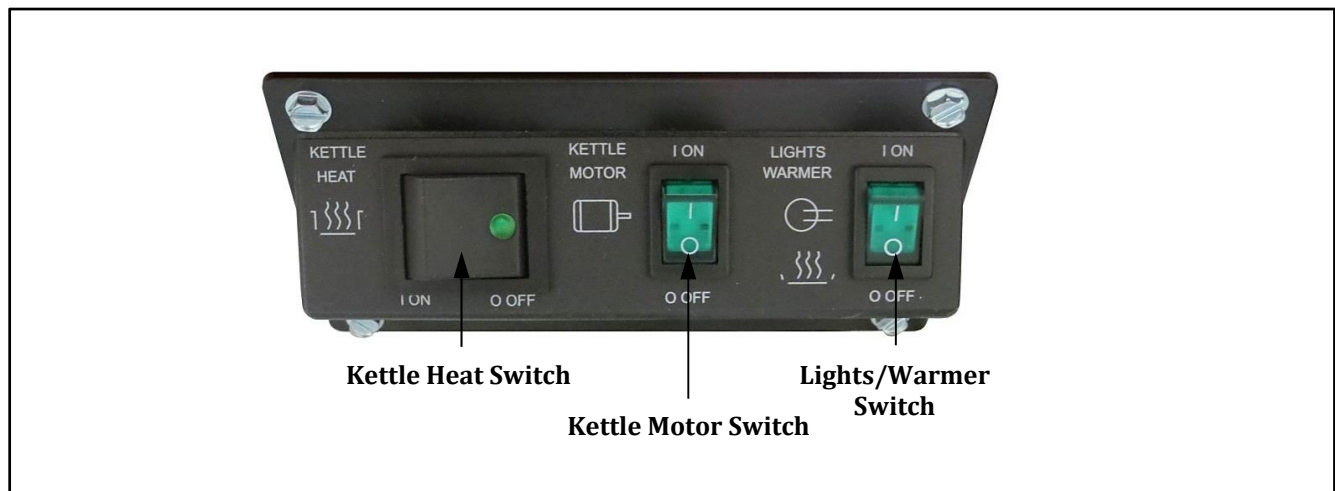

Popping Corn Instructions

This section describes instructions for popping Salted Popcorn.

The popper is equipped with a corn, salt, and oil measure. We recommend flavored and colored coconut oil. Popcorn popped in coconut oil stays fresh longer and does not leave black deposits in the kettle like other oils. Use only top quality, fresh popcorn from reputable suppliers.

Popping Salted (Standard) Popcorn

Raw Popcorn Charge:	Use corn measure provided (ex: for 6 oz. Kettle, use 6 oz. corn)
Recommended Oil Volume:	Oil volume is approx. 30% of corn amount (ex: for 6 oz. corn, use 2 oz. oil)
Flavacol (Salt) Amount:	Use small Flavacol scoop provided

Premeasure all ingredients (adjust as needed for desired taste), or for best results use Mega-Pop® premeasured popcorn and oil pouch made for your kettle size.

1. Turn all switches ON.
2. To determine when kettle is ready to pop corn (about 4 minutes), test pop three kernels of corn in one ounce (30 ml) of popping oil. When kernels pop, kettle is ready.
3. Lift kettle lid, pour in popcorn and Flavacol, then add oil; close lid.
4. When corn has finished popping, gently dump the popcorn.

Popping Tip: On final batch, turn Kettle Heat Switch OFF just as lids are forced open by the popping corn (kettle has plenty of heat to finish popping). This helps eliminate smoke/odor from any oil residue remaining in kettle.

5. When finished popping, turn KETTLE HEAT and KETTLE MOTOR switches OFF.
NEVER LEAVE THE HEAT ON WHEN YOU ARE NOT POPPING CORN!

Care and Cleaning

	⚠ DANGER
	Machine must be properly grounded to prevent electrical shock to personnel. DO NOT immerse in water. DO NOT clean appliance with a water jet. Always unplug the equipment before cleaning or servicing. 025_111616

	⚠ WARNING
	To avoid serious burns, DO NOT touch the kettle while it is hot! 028_082715

Good sanitation practice demands that all food preparation equipment be cleaned regularly (only use non-toxic, food grade cleaners). A clean looking, well-kept machine is one of the best ways of advertising your product.

Note: It is extremely important to follow all of the cleaning procedures, otherwise parts damage and equipment failure will result. The warranty does not cover parts that are damaged due to improper cleaning.

Daily Kettle Cleaning Instructions

CAUTION: A hot kettle will cause burns if you touch it with your hand. Allow kettle to cool at least 1 hour before attempting to clean. **DO NOT** use ice or water to cool down a hot kettle! Severe kettle damage will result!

1. When cool, wipe the **outside** of the kettle with a clean, soft cloth. **DO NOT** use oven cleaners or abrasive materials as they will damage the kettle.
2. Every night, mix Heat'n Kleen solution, 2 tablespoons per gallon of water. It is not necessary to use the entire gallon at once; only use enough to fill the kettle 1/2 inch deep.
3. Turn the kettle heat ON. When the water starts to boil, turn the kettle heat OFF.
4. Allow to cool for at least 1 hour, then dump the solution into a bucket and wipe the inside of the kettle with a clean cloth. Make sure all of the solution goes into the bucket; do not spill any in the interior of the machine.

For extra dirty kettles, the process may be repeated; or, after turning the kettle heat OFF, allow solution to sit in the kettle overnight. The next morning, dump the solution into a bucket and wipe the inside of the kettle with a clean cloth.

5. With the unit OFF and unplugged, wipe the kettle lead cord with a clean **SLIGHTLY** damp cloth. **DO NOT get moisture into the kettle lead-in cord, severe damage will result.**

Daily Unit Cleaning Instructions

1. With the machine OFF, unplug the unit and allow it to cool before attempting to clean.
2. Make sure to clean all pans/accessories in order to sanitize them before each use.
3. Take a clean, SLIGHTLY damp cloth and wipe excess grease from the glass and cabinet.
4. Wipe the stainless steel parts with a clean cloth and cleaner designed for stainless steel, such as Watchdog Stainless Cleaner.

DO NOT use oven cleaners or abrasive materials as they will damage parts of the machine.

5. Clean the glass panels with glass cleaner. Watchdog Glass Cleaner is recommended.

Ammonia cleaners will damage the plastic doors. Use only non-ammonia cleaners, such as Watchdog Glass Cleaner.

Troubleshooting

Issue	Possible Cause	Solution
No Power to the Unit	A. No Power to the Unit	A. Make sure the unit's power cord is plugged in.
Kettle Does Not Heat	A. Power to the Kettle B. Kettle Heat Switch C. Heating Element	A. Make sure kettle lead-in cord is plugged in and twisted to lock into the kettle receptacle. B. Have a qualified service person check the voltage to and from the Kettle Heat Switch; if switch is defective, replace it. C. Heating element in the kettle may be burned out. Check with a qualified service person for inspection/repair.
Long Popping Cycles (Longer than 4 minutes for Salt Popcorn)	A. Low Voltage B. Inadequate Supply Lines C. Inferior Corn	A. If the machine is operated on low voltage, this could cause the kettle not to reach the proper operating temperature. Check with a qualified electrician. B. Inadequately sized electrical supply lines or use of extension cord, in addition to being a fire hazard, would also prevent the kettle from reaching the proper operating temperature. Check with a qualified electrician. C. Inferior quality corn would result in longer popping cycles. Use only top quality hybrid popcorn from reputable suppliers. Even then, if you let your corn pick up moisture or dry out, your popping cycles will be slow.
Kettle Agitator Shaft not Rotating If the kettle agitator shaft is not rotating, DO NOT pop corn.	A. Kettle Motor Switch B. Kettle Agitator Shaft/Stir Blade not rotating. (Unit must be OFF, unplugged and cool prior to checking or adjusting the agitator assembly.)	A. Make sure the Kettle Motor Switch is ON. If the switch is ON, and the shaft is not rotating, the switch or motor may be faulty, contact qualified service personnel for inspection/repair. B. Kettles with a FLOATING Stir Rod – lift the agitator weight and check the clearance between the shaft and the kettle bottom; it should be a minimum of 1/32" (thickness of a dime). To make shaft adjustments, reference the Agitator Set Collar Adjustment section.

Agitator Set Collar Adjustment

The following instructions describe how to properly adjust set collars on an agitator assembly with a floating stir rod.

Agitator Assembly with a FLOATING Stir Rod

Steps to Adjust Set Collars

Step 1: Turn machine OFF, unplug unit, and allow it to cool completely before attempting to adjust the agitator height.

Step 2: Loosen the set screw in each set collar to be adjusted.

Step 3: With the kettle mounted in the popper, adjust the shaft so the Spur Gears are halfway engaged, and the Needle Bearing is at least halfway engaged in the gear block (reference image at right).

DO NOT set spur gears at full gear contact; it can cause binding as the kettle is dumped.

Step 4: Snug tighten only, the set screw in set collar above the crossbar to hold position. Then, lift the agitator weight and check the clearance between the shaft and the kettle bottom. If there is adequate clearance, fully tighten the set screw to secure set collar in place.

Step 5: Adjust clearance between the bottom of the crossbar and the lower set collar to $1/32$ " (thickness of a dime); then re-tighten set screw to secure in place (reference image).

Step 6: Adjust set collar for agitator weight to be between $3/16$ " to $1/4$ " above the agitator weight. Once adjusted, re-tighten set screw to secure in place.

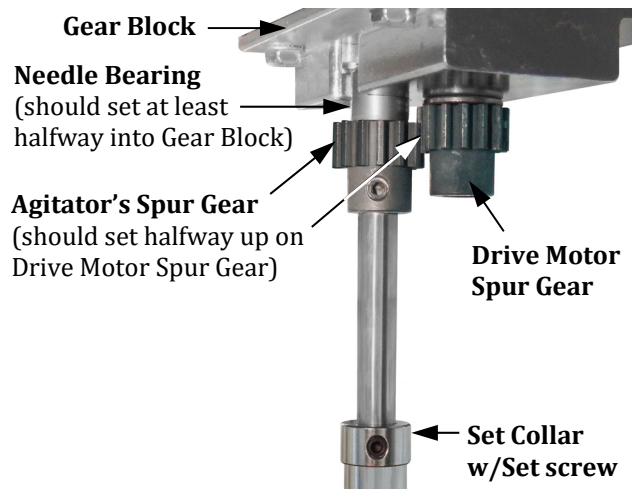

Agitator shown for general image reference only (lids not shown for clarity).



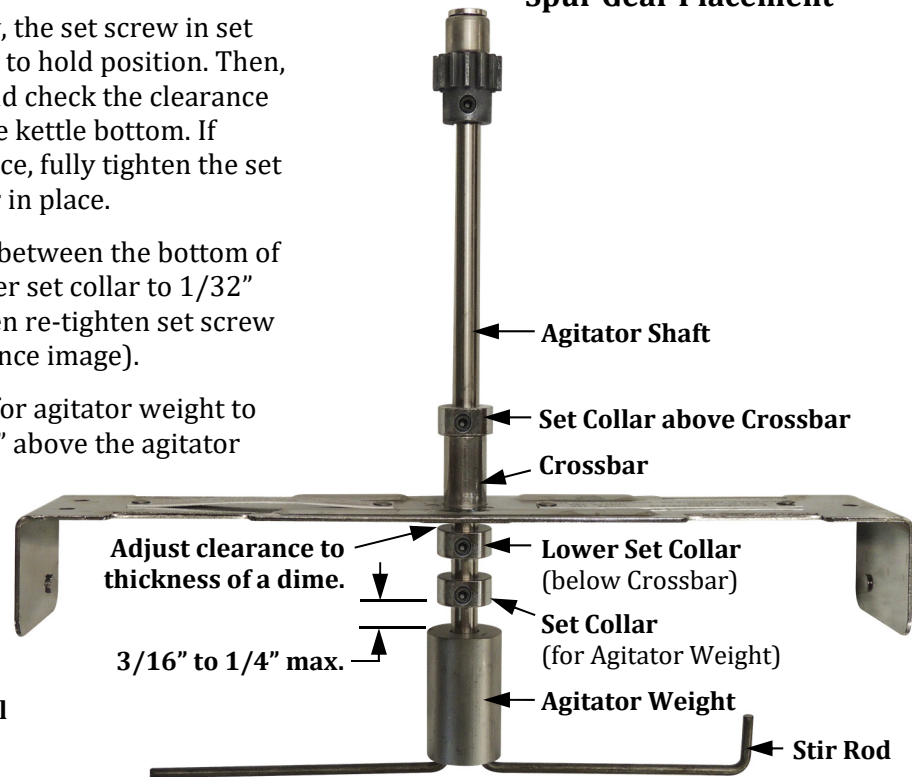

Spur Gear Placement





MAINTENANCE INSTRUCTIONS

	 DANGER
	<p>Machine must be properly grounded to prevent electrical shock to personnel. Failure to do so could result in serious injury, or death. DO NOT immerse any part of this equipment in water. DO NOT use excessive water when cleaning. Keep cord and plug off the ground and away from moisture. Always unplug the equipment before cleaning or servicing. Make sure all machine switches are in the OFF position before plugging the equipment into the receptacle.</p> <p>008_051514</p>

	 DANGER
	<p>Improper installation, adjustment, alteration, service, or maintenance can cause property damage, injury, or death. Any alterations to this equipment will void the warranty and may cause a dangerous condition. This appliance is not intended to be operated by means of an external timer or separate remote-control system. NEVER make alterations to this equipment. Read the Installation, Operating, and Maintenance Instructions thoroughly before installing, servicing, or operating this equipment.</p> <p>014_020416</p>

	 WARNING
	<p>No user serviceable parts inside. Refer servicing to qualified service personnel.</p> <p>011_051514</p>

	 CAUTION
	<p>THE FOLLOWING SECTIONS OF THIS MANUAL ARE INTENDED ONLY FOR QUALIFIED SERVICE PERSONNEL WHO ARE FAMILIAR WITH ELECTRICAL EQUIPMENT. THESE ARE NOT INTENDED FOR THE OPERATOR.</p> <p>027_010914</p>

ORDERING SPARE PARTS

1. Identify the needed part by checking it against the photos, illustrations, and/or parts list. (General images may be used in manual for reference only.)
2. Use only approved replacement parts when servicing this unit.
3. When ordering, please include part number, part name, and quantity needed.
4. Please include your model number, serial number, and date of manufacture (located on the machine nameplate/data plate) with your order.
5. Place orders by phone or online:

Phone: 800.782.6761

Fax: 419.542.6690

Web Page: www.nemcofoodequip.com

Replacing Broken Glass

GLASS DIMENSIONS (Height x Width x Thickness)

Front Glass: 22 3/8" X 16 15/16" X 1/8" (1 Piece)

Side Glass: 22 3/8" X 14 15/16" X 1/8" (2 Pieces)

1. Turn machine OFF, unplug unit and allow it to cool before attempting to replace glass.
2. Remove all loose pieces of glass (popper units: kettle may be removed to change glass).
3. Place a bungee (or large rubber band) around the unit to help hold the corner posts in place, then remove dome.
4. Remove all rigid glass channels from around glass to be replaced, set channels aside for reuse.
Note: The rigid channels may be wedged in the corner posts or top and bottom glass extrusions, and must be removed before new glass can be installed.
5. Carefully remove the rest of the broken glass.
6. Apply decals (if desired) to new glass panel.
7. Slide rigid glass channels over exposed sides and bottom of new glass panel.
8. Lift motor plate just enough to allow the new glass panel to slide into the corner posts and down into the bottom glass extrusion.
9. Carefully lower the motor plate until the top glass extrusion secures glass in place.
10. Reinstall dome, and remove bungee (popper units: reinstall kettle if removed).

Cabinet Exterior – Rear View



Item	Part Description	Part Number
		GS1508
1	GREEN LIGHTED ROCKER SWITCH	10405
2	DPST ROCKER SWITCH	10411
3	KNOB LID LIFT	10408
4	TEE BOLT	10410
5	PLEXIGLASS DOOR	10407
6	FEMALE HINGE LEFT HAND	10412
7	FEMALE HINGE RIGHT HAND	10413
8	OLD MAID PAN	10409
	MANUAL	10432

PRODUCT WARRANTY

Except as otherwise provided below, Nemco Food Equipment, Ltd. ("Nemco") warrants, to the original user, its electrical/pneumatic products (other than blades and light bulbs) to be free of electrical and mechanical defects in material and workmanship under "normal use" (defined below) for the shorter of the following periods: (a) one (1) year from the date placed in service by the original user, or (b) 18 months from the date of shipment from its factory. Nemco also warrants its food preparation products (other than blades) to be free of mechanical defects in material and workmanship under normal use for two (2) years from the date placed in service by the original user. In addition, Nemco warrants its Global Solutions food preparation and electrical products (other than blades) to be free of mechanical defects in material and workmanship under normal use for one (1) year from the date placed in service by the original user. The warranty provided for herein shall be limited to parts and labor. Any determination that a product is defective or covered by this warranty, shall be made by Nemco, in its sole discretion. The determination of whether to repair or replace a defective, covered product, or to refund the purchase price for the product, will be at Nemco's sole discretion. This warranty does not cover products used outside the United States, or damages caused by accident, misuse, negligence of any person other than Nemco, current or voltage other than stated on the appliance, fire, flood or other casualty. Any alteration to the product or unauthorized repair voids this warranty. For purposes of this warranty, the phrase, "normal use" shall mean the use of the product in connection with food in accordance with the product manual accompanying the product.

Nemco shall be responsible only for repairs or replacements of defective parts performed by Nemco's authorized service personnel. Authorized service agencies are located in principal cities throughout the continental United States, Alaska and Hawaii.

THE FOREGOING WARRANTY IS EXCLUSIVE AND IN LIEU OF ALL OTHER WARRANTIES, EXPRESS OR IMPLIED. NEMCO EXPRESSLY DISCLAIMS ANY IMPLIED WARRANTY THAT ANY OF ITS PRODUCTS IS MERCHANTABLE, FIT FOR A PARTICULAR PURPOSE, OR DOES NOT INFRINGE ON THE RIGHTS OF ANY THIRD PARTY. THE FOREGOING WARRANTY SHALL BE NEMCO'S SOLE AND EXCLUSIVE OBLIGATION. ANY PERSON'S (BUYER, USER OR OTHERWISE) EXCLUSIVE REMEDY AGAINST NEMCO, AND NEMCO'S SOLE OBLIGATION, FOR ANY AND ALL CLAIMS, WHETHER FOR BREACH OF CONTRACT, WARRANTY, TORT (INCLUDING WITHOUT LIMITATION NEGLIGENCE), OR OTHERWISE, SHALL BE LIMITED TO NEMCO REPAIRING OR REPLACING THE PRODUCT, OR, AT NEMCO'S OPTION, REFUNDING THE PURCHASE PRICE THEREFOR. IN NO EVENT SHALL NEMCO HAVE ANY LIABILITY FOR DAMAGES IN AN AMOUNT EXCEEDING THE PURCHASE PRICE OF THE PRODUCT, NOR SHALL NEMCO HAVE ANY LIABILITY FOR INCIDENTAL, SPECIAL OR CONSEQUENTIAL DAMAGES. Any person desiring to make any claim against Nemco must do so within six (6) months after expiration of the applicable warranty period, or such claim shall be forever barred.

NOTE: WARRANTY DOES NOT COVER DAMAGE TO THE GRID OR GRID COATING. IT IS NEMCO'S SOLE DISCRETION TO DETERMINE IF A GRID OR GRID COATING CLAIM IS WARRANTED.

NOTE: WARRANTY DOES NOT COVER DAMAGE TO THE ROLLERS OR ROLLER COATING. IT IS NEMCO'S SOLE DISCRETION TO DETERMINE IF A ROLLER OR ROLLER COATING CLAIM IS WARRANTED.

NOTE: PLEASE REVIEW YOUR PRODUCT MANUAL FOR SPECIFIC WATER REQUIREMENTS. DISTILLED OR TREATED WATER MAY BE REQUIRED. PRODUCT FAILURE DUE TO SEDIMENT AND LIME BUILDUP IS NOT COVERED UNDER WARRANTY.

PRODUCT SERVICE

Nemco has a staffed service department, and we believe prompt service is extremely important to our customers. Therefore, we request all product service inquiries be handled in the following manner:

- (1) The end user should call Nemco Customer Service with the company name, address, phone number, model number, serial number (if applicable), Nemco Sales Order number or Dealer Purchase Order number and the nature of the problem (the "Claim Information").
- (2) The Nemco Customer Service Department will decide on the most appropriate course of action. If Nemco determines that it must inspect a product, the following procedure will be followed:

The end user will obtain a Return Goods Authorization number from Nemco Customer Service to return the product to Nemco for inspection. Please be sure to use this number on the box and on paperwork sent with the unit. Return the unit to Nemco. The Nemco Service Department will determine if the problem is covered by the foregoing warranty. If so, Nemco will repair the unit and return it to the end user. If the unit is determined not to be covered by the foregoing warranty, the dealer will be contacted to determine the next course of action. If the unit weighs less than 70 lbs., it will be considered a carry-in warranty. The service agent performing the service must call Nemco Customer Service to obtain a Service Authorization number and provide the Claim Information. If the unit weighs 70 lbs. or more, it will be considered an on-site warranty, and the service agent performing the service must call Nemco Customer Service to obtain a Service Authorization number and provide the Claim Information.

TERMS & CONDITIONS

- No merchandise shall be returned without prior written authorization.
- All returned merchandise must be unused, in original carton and shipped prepaid.
- All returned merchandise is subject to a 25% restocking charge.
- No returns will be accepted after 90 days of shipping date.
- Purchaser should make claim directly to carrier for any damages to merchandise that occur in transit.
- This Price List supersedes all previous price lists.
- Orders with an invoice value of \$2,100 net or more will be shipped freight prepaid to one destination in the continental United States.
- Terms are COD, CIA or Net 30 days with approved credit.
- Buyer shall pay all applicable federal, state and municipal sales or use tax.
- No minimum order charge.
- Prices subject to change without notification.



nemco® | FOOD EQUIPMENT

301 Meuse Argonne Hicksville, OH 43526 • P:800.782.6761 • F:419.542.6690

Visit us at www.nemcofoodequip.com for more information



MODEL NUMBER CROSS REFERENCE

Global Solutions	Gold Medal Products Co.
GS1508	2388-00-015

Approvals / Listings for Global Solutions Poppers:

Our popcorn poppers are manufactured to Global Solutions (a Nemco Food Equipment Company) specifications by Gold Medal Products Co., USA.

Unit is UL Listed for US and Canada, and NSF approved.

The above mentioned certifications are listed under the unit manufacturer, Gold Medal Products Co.