

INSTALLATION INSTRUCTIONS**Single Package Heat Pump - Single Stage, R-410A****IMPORTANT****ATTENTION INSTALLERS:**

It is your responsibility to know this product better than your customer. This includes being able to install the product according to strict safety guidelines and instructing the customer on how to operate and maintain the equipment for the life of the product. Safety should always be the deciding factor when installing this product and using common sense plays an important role as well. Pay attention to all safety warnings and any other special notes highlighted in the manual. Improper installation of the furnace or failure to follow safety warnings could result in serious injury, death, or property damage.

These instructions are primarily intended to assist qualified individuals experienced in the proper installation of this appliance. Some local codes require licensed installation/service personnel for this type of equipment. Please read all instructions carefully before starting the installation. Return these instructions to the customer's package for future reference.

DO NOT DESTROY. PLEASE READ CAREFULLY AND KEEP IN A SAFE PLACE FOR FUTURE REFERENCE.

TABLE OF CONTENTS

Important Safety Information	3	Anti Short Cycle Timer Test	11
Requirements & Codes	4	Heating Mode	11
General Information	4	Cooling Mode	11
Before You Install this Unit	4	Adjustment of Refrigerant Charge	11
Locating the Heat pump	4	Charging the Unit in AC Mode with Outdoor	
Minimum Clearances	5	Temperatures above 65° F	12
Service Access Clearance	5	Charging the Unit in Heat Mode	12
Clearances to Combustibles	5	Unit Maintenance	12
Air Duct System	5	Component Functions	12
Unconditioned Spaces	5	Figures & Tables	13
Heat Pump Installation	5	Figure 8 - Physical Data & Dimensions	13
Unpacking the Unit	5	Charging Tables - Cooling Mode	14
Installing Return & Supply Air Collars	5	Table 3 - 2 Ton Models (024K Series)	14
Supply Duct	6	Table 4 - 2.5 Ton Models (030K Series)	14
Return Duct	6	Table 5 - 3 Ton Models (036K / 36KA Series)	15
Connecting Return & Supply Air		Table 6 - 3.5 Ton Models (042K Series)	15
Flexible Ducts	6	Table 7 - 4 Ton Models (048K Series)	16
Locating & Installing the Return Air		Figure 9 - 4 Ton Models (048KA Series)	16
Assembly	6	Table 8 - 5 Ton Models (060K Series)	16
Locating & Installing the Supply		Charging Tables - Heating Mode	17
Dampers	7	Table 9 - 2 Ton Models (024K Series)	17
Condensate Drainage	7	Table 10 - 2.5 Ton Models (030K Series)	17
Electrical Connections	7	Table 11 - 3 Ton Models (036K / KA Series)	18
Pre - Electrical Checklist	7	Table 12 - 3.5 Ton Models (042K Series)	19
Line Voltage	7	Table 13 - 4 Ton Models (048K Series)	19
Overcurrent Protection	8	Table 14 - 4 Ton Models (048KA Series)	20
Grounding	8	Table 15 - 5 Ton Models (060K Series)	20
Thermostat Connections	8	Electrical Diagrams	21
Defrost Cycle Control	8	Figure 10 - 2, 2.5, 3, & 4 Ton Models	21
Defrost Control Board	9	Figure 11 - 3.5 & 5 Ton Models	22
Operational Information	9	Figure 12 - Typical T-stat Connections	23
Normal Mode	9	Installation / Performance Checklist	24
Speed Up Mode (Testing Procedure)	9		
Electric Heat Package	9		
Blower Speed	10		
Startup & Adjustments	11		
Pre - Start Checklist	11		
Start - Up Procedure	11		
Air Circulation	11		
System Heating	11		
System Cooling	11		
Short Cycle Protection	11		
Emergency Heat	11		

IMPORTANT SAFETY INFORMATION

Please read all instructions before servicing this equipment. Pay attention to all safety warnings and any other special notes highlighted in the manual. Safety markings are used frequently throughout this manual to designate a degree or level of seriousness and should not be ignored. **WARNING** indicates a potentially hazardous situation that if not avoided, could result in personal injury or death. **CAUTION** indicates a potentially hazardous situation that if not avoided, may result in minor or moderate injury or property damage.

WARNING:

ELECTRICAL SHOCK, FIRE OR EXPLOSION HAZARD

Failure to follow safety warnings exactly could result in serious injury or property damage.

Improper servicing could result in dangerous operation, serious injury, death or property damage.

- Before servicing, disconnect all electrical power to the indoor blower.
 - When servicing controls, label all wires prior to disconnecting. Reconnect wires correctly.
 - Verify proper operation after servicing.
-

WARNING:

These units are fully charged with R-410A refrigerant and ready for installation. When a system is installed according to these instructions, no refrigerant charging is required. If repairs make it necessary for evacuation and charging, it should only be attempted by qualified, trained personnel thoroughly familiar with this equipment. Some local codes require licensed installation service personnel to service this type of equipment. Under no circumstances should the homeowner attempt to install and/or service this equipment. Failure to comply with this warning could result in equipment damage, personal injury, or death.

WARNING:

Do not place combustible material on or against the unit cabinet. Do not place combustible materials, including gasoline and any other flammable vapors and liquids, in the vicinity of the unit.

WARNING:

PROPOSITION 65 WARNING: This product contains fiberglass wool, a product known to the state of California to cause cancer. Disturbing the insulation of this product during installation, maintenance, or repair will expose you to fiberglass wool.

- Breathing this material may cause respiratory irritations or may cause lung cancer.
 - Fiberglass wool may also cause eye irritation, skin sensitization, or other allergic responses in susceptible individuals.
 - Always wear goggles, disposable gloves, long sleeved shirt, and appropriate breathing protection when working near this insulation. If contact with skin occurs, wash immediately with soap and water. In case of contact with eyes, flush immediately with water for at least 15 minutes. Contact a physician if needed.
-

WARNING:

The information listed below and on the next page must be followed during the installation, service, and operation of this unit. Unqualified individuals should not attempt to interpret these instructions or install this equipment. Failure to follow safety recommendations could result in possible damage to the equipment, serious personal injury or death.

- Before beginning the installation, verify that the unit model is correct for the job. The unit model number is printed on the data label.
- This equipment contains liquid and gaseous refrigerant under high pressure. Installation or servicing should only be performed by qualified trained personnel thoroughly familiar with this type equipment.
- Installation of equipment may require brazing operations. Installer must comply with safety codes and wear appropriate safety equipment (safety glasses, work gloves, fire extinguisher, etc.) when performing brazing operations.
- The installer should become familiar with the units wiring diagram before making any electrical connections to the unit. See the unit wiring label or Figures 10 & 11 (pages 21 & 22).
- Follow all precautions in the literature, on tags, and on labels provided with the equipment. Read and

thoroughly understand the instructions provided with the equipment prior to performing the installation and operational checkout of the equipment.

- Use caution when handling this appliance or removing components. Personal injury can occur from sharp metal edges present in all sheet metal constructed equipment.

REQUIREMENTS & CODES

- All electrical wiring must be completed in accordance with local, state & national codes and regulations and with the National Electric Code (ANSI/NFPA 70) or in Canada the Canadian Electric Code Part 1 CSA C.22.1.
- The installer must comply with all local codes and regulations which govern the installation of this type of equipment. Local codes and regulations take precedence over any recommendations contained in these instructions. Consult local building codes and the National Electrical Code (ANSI C1) for special installation requirements.
- Air Ducts must be installed in accordance with the standards of the National Fire Protection Association “Standards for Installation of Air Conditioning and Ventilation Systems” (NFPA 90A), “Standard for Installation of Residence Type Warm Air Heating and Air Conditioning Systems” (NFPA 90B), these instructions, and all applicable local codes.
- Consult Table 2 (page 10), and the rating plate for the proper circulating air flow and temperature rise. It is important that the duct system be designed to provide the correct flow rates and external pressure rise. An improperly designed duct system can result in nuisance shutdowns, and comfort or noise issues.
- This unit is designed for outdoor installations only and should be positioned as described in Locating the Heat Pump.

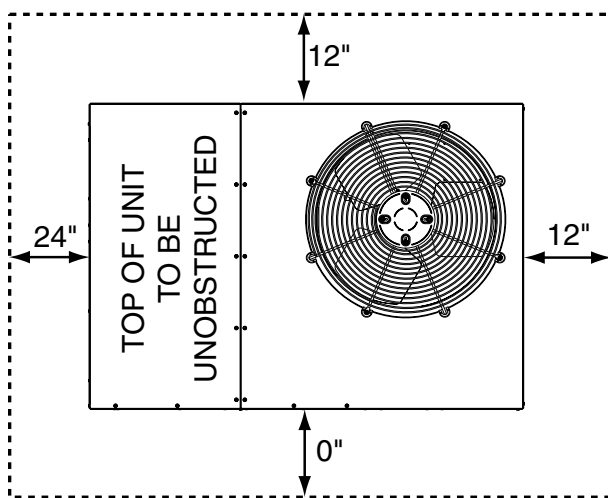

Figure 1. Minimum Unit Clearances

GENERAL INFORMATION

Single packaged heat pumps are ready for easy and immediate installation and can be readily connected into the high static duct system of a home. This unit is completely assembled, wired, and run tested at the factory. **This heat pump is designed for outdoor installation only.** The only connections needed for installation are the supply and return ducts, the line voltage, and thermostat wiring. Use of components other than those specified may invalidate AHRI Certification, Code Agency Listing, and limited warranty on the air conditioner.

Before You Install this Unit

- ✓ The cooling load of the area to be conditioned must be calculated and a system of the proper capacity selected. It is recommended that the area to be conditioned be completely insulated and vapor sealed.
- ✓ Check the electrical supply and verify the power supply is adequate for unit operation. If there is any question concerning the power supply, contact the local power company.
- ✓ All units are securely packed at the time of shipment and upon arrival should be carefully inspected for damage prior to installing the equipment at the job site. Verify coil fins are straight. If necessary, comb fins to remove flattened or bent fins. Claims for damage should be filed immediately with the carrier.
- ✓ Please consult your dealer for maintenance information and availability of maintenance contracts. Please read all instructions before installing the unit.

Locating the Heat Pump

- Survey the job site to determine the best location for mounting the outdoor unit. Select a solid, level position, preferably on a concrete slab, slightly above the grade level, and parallel to the home. If possible, select a site for the unit that is as close as possible to the proposed return grille location. **DO NOT PLACE UNIT UNDER THE HOME.**
- The unit should be located with consideration of minimizing the length of the supply and return ducts with no sharp radius bends. If practical, place the heat pump and its ducts in an area where they will be shaded from the afternoon sun, when the heat load is greatest.
- Consideration should also be given to availability of electric power, service access, noise, and shade.
- Overhead obstructions, poorly ventilated areas, and areas subject to accumulation of debris should be avoided. The hot condenser air must be discharged up and away from the home, and if possible, in a direction with the prevailing wind. Do not place the unit in a confined space. See Figure 8 (page 13) for unit dimensions.
- Sufficient clearance for unobstructed airflow through the outdoor coil must be maintained in order to achieve rated performance. For minimum clearances to obstructions, see Figure 1.

Minimum Clearances

Minimum clearances MUST be maintained from adjacent structures to provide room for proper servicing and air circulation. DO NOT install unit in a confined or recessed area that will allow discharge air from the unit to re-circulate into the condenser air inlet, through the coil. See Figure 1.

Service Access Clearance:

Blower access panel side	24"
Electrical compartment access panel side	12"
Clearance between overhang and top of unit	72"
Clearance around condenser coil area to wall or shrubs (excludes duct panel side).....	12"

Clearances to Combustibles:

Combustible base - wood or Class A, B, or C roof covering material	0"
Supply & return air ducts	0"
Duct connection side	0"

Air Duct System

Air ducts should be installed in accordance with the standards of the National Fire Protection Association "Standard for Installation of Air Conditioning and Ventilation Systems" (NFPA 90A), "Standard for Installation of Residence Type Warm Air Heating and Air Conditioning Systems" (NFPA 90B), these instructions, and all applicable codes. NFPA publications are available by writing to: National Fire Protection Association, Batterymarch Park, Quincy, ME 02269 or visit www.NFPA.org on the web.

- Design the duct work according to methods described by the Air Conditioning Contractors of America (ACCA).
- The supply duct system (Figure 3, page 6), including the number and type of registers, will have much more effect on the performance of the system than any other factor. The duct must be sufficiently large to conduct an adequate amount of air to each register.
- Duct work should be attached directly to the unit flanges for horizontal applications.
- For highly resistive duct systems it may be necessary to add an additional return air duct and or supply to achieve maximum performance and prevent coil icing and refrigerant flood back.
- **The heat pump system will not cool or heat the home if air is lost to the outside through leaks in the duct system. Ducts that are collapsed or restricted by foreign objects will also prevent adequate air flow.**
- All duct work passing through unconditioned space must be properly insulated to minimize duct losses and prevent condensation. Use insulation with an outer vapor barrier. Refer to local codes for insulation material requirements.

Unconditioned Spaces

All duct work passing through unconditioned space must be properly insulated to minimize duct losses and prevent condensation. Use insulation with an outer vapor barrier. Refer to local codes for insulation material requirements.

The heat pump system will not cool or heat the home if air is lost to the outside through leaks in the duct system. Ducts that are collapsed or restricted by foreign objects will also prevent adequate air flow.

HEAT PUMP INSTALLATION

Unpacking the Unit

It is recommended that the unit be unpacked at the installation site to minimize damage due to handling.

CAUTION:

Do not tip the unit on its side. Oil may enter the compressor cylinders and cause starting trouble. If unit has been set on its side, restore to upright position and do not run for several hours. Then run unit for a few seconds. Do this three or four times with five minutes between runs.

1. Remove the bands from around the unit.
2. Unfold the top and bottom cap flanges.
3. Carefully remove the top cap and tube.

Installing Return & Supply Air Collars

If the supply and return collars are supplied with the unit, they will be located in the supply duct. They can be easily positioned over the unit openings (Figure 2) and secured with sheet metal screws.

- The diameter of the return duct collar is 14".
- **NOTE:** 2 ton units are designed with 12" returns.
- The diameter of the supply duct collar is 12".
- Before permanently installing the collars, it is recommended you pre-fit them over the openings first to determine best fit and alignment.

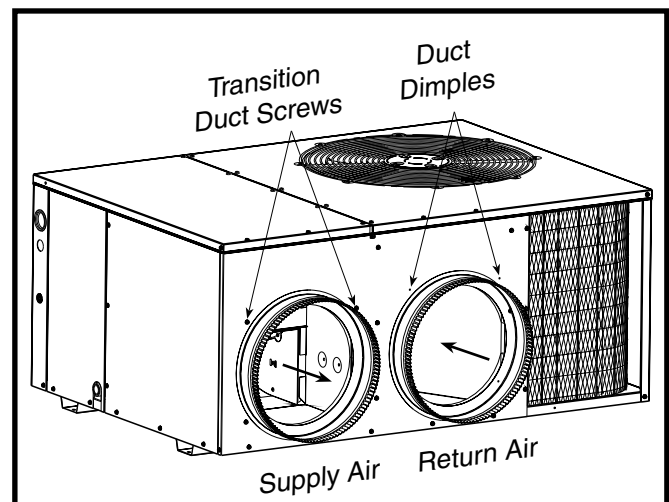

Figure 2. Return & Supply Air Collars

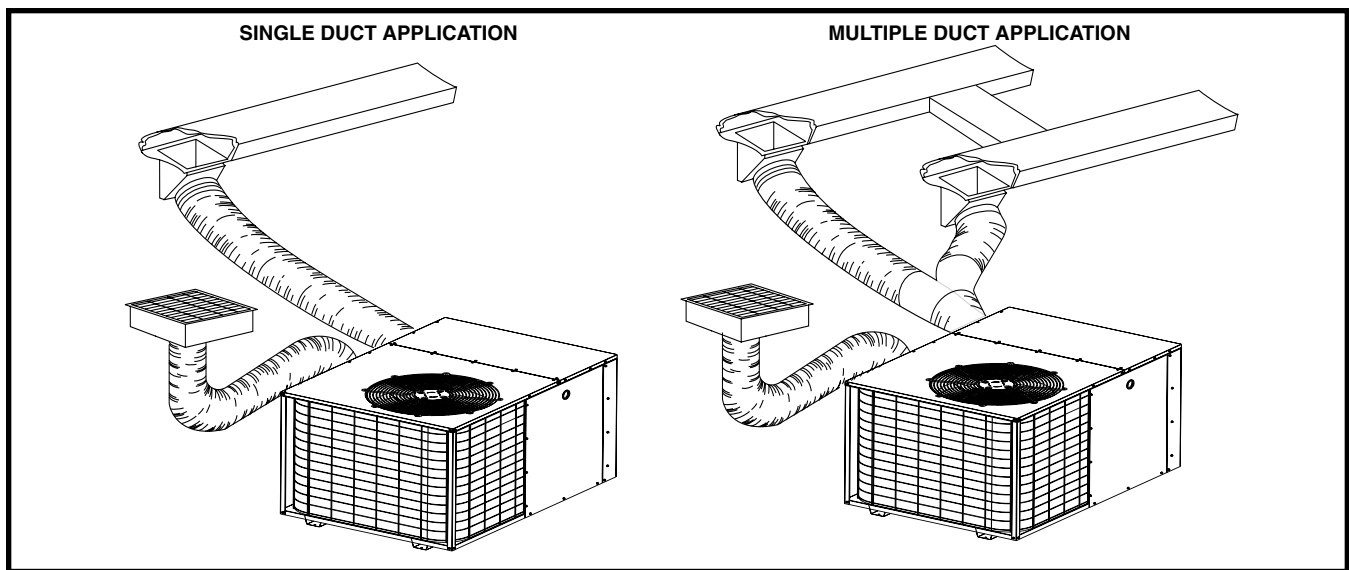

Figure 3. Typical Duct Applications

Supply Duct

1. Assemble the collar by overlapping the two ends.
NOTE: One end of the collar is slotted and the opposite end has two small holes. Position the end with small screw holes underneath the slotted end.
2. Fasten the collar ends with two self drilling sheet metal screws.
3. Position the collar over the opening and align the 4 holes in the collar with the 4 holes (or dimples depending on model) in the rear panel.
4. Using self-drilling screws (10-16x.5), secure the collar to the rear panel.

Return Duct

1. Assemble the collar by overlapping the two ends.
NOTE: One end of the collar is slotted and the opposite end has two small holes. Position the end with small screw holes underneath the slotted end.
2. Fasten the collar ends with two self drilling sheet metal screws.
3. Position the collar over the opening. Align the four holes in the collar with the four dimples or holes (depending on unit model) in the panel.
4. Secure the collar to the rear panel using self tapping screws (10-16x.5).

Connecting Return & Supply Air Flexible Ducts

- Flexible ducts may be cut to the required length and spliced with sheet metal sleeves and clamps. **Keep all ducts as short and straight as possible. Avoid sharp bends.** Please follow all instructions packed with duct.
- Flexible ducts can be secured to the corresponding collars with the provided clamps. After the inner duct is connected to the collar, pull the insulation and plastic sleeve over the connection and clamp. **NOTE:** To prevent a loss in cooling capacity, make sure all connections are tight.

- Homes with multiple supply ducts (or special applications), a Y fitting is available for dividing the supply air to different areas of the home for more efficient cooling. **NOTE:** For maximum performance, insulate the Y fitting.

Locating & Installing the Return Air Assembly

To simplify installation, locate and install the return air assembly first. If desired, the return opening can be located inside a closet with louvered doors that has an open area equal to or greater than a 12" x 20" grille. The return air grille can be placed in the wall of a closet and the ducted into the filter box through a boxed-in area at the closet floor level. **Make sure the filter is readily accessible.**

NOTE: The return air box with grille and filter (Figure 4, page 7) should not be located in heavy traffic areas like hallways or center of rooms. A good spot is in a corner or under a table, if a minimum two inch clearance is available.

1. Start the installation from under the home by cutting a small hole in the sub-floor. Determine how the floor joist location will affect cutting the opening needed for the return air box. **NOTE:** Floor joists are generally located on 16" centers, leaving 14-3/8" between joists.
2. After measuring the return air box (approximately 12-1/4" x 20-1/4"), cut the hole through the floor so that the box will fit between the floor joists. Care should be taken when cutting through carpeting to avoid snags. **NOTE:** In most installations it will be necessary to cut a similar hole in the fiberboard directly under the hole in the floor. However, if the floor is more than ten inches deep, it will only be necessary to cut a hole for the collar on the return air box or for the insulated duct.
3. Set the box into the opening and fasten with screws or nails.
4. Install the filter and return air grille in place.

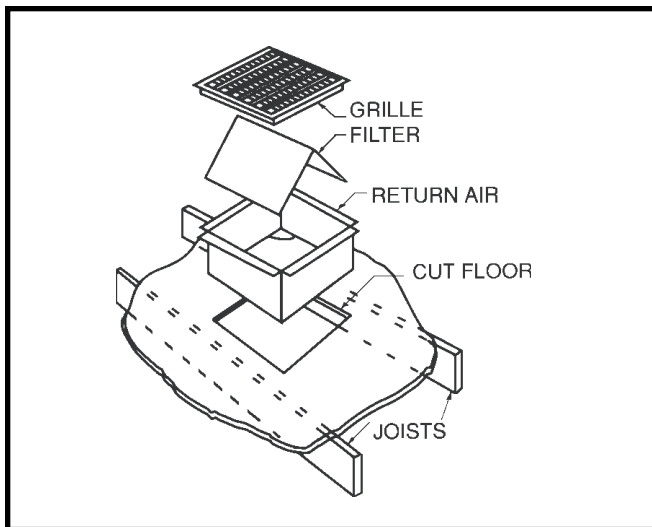

Figure 4. Return Air Box

Locating & Installing the Supply Damper(s)

When locating the supply damper(s), carefully check floor joists and frame members that could interfere with the installation of the damper or flexible duct. Ideally, the damper (Figure 5) should be located in the bottom of the main duct, forward of center of the home, at least three feet from the nearest register. The round supply opening in the slanted side of the damper should face the side of the home where the heat pump is located.

1. Locate the center of the heat duct by cutting a small hole in the fiberboard below the duct at the desired location.
2. Cut a hole approximately 3/4" larger than the damper opening in the fiberboard.
3. Cut a 9-1/8" x 13-1/8" hole in the duct and bend over all tabs flat on the inside of the heat duct.
4. Insert the damper into the duct and bend over all tabs flat on the inside of the heat duct.
5. Seal the opening between the fiberboard and damper or flexible duct.

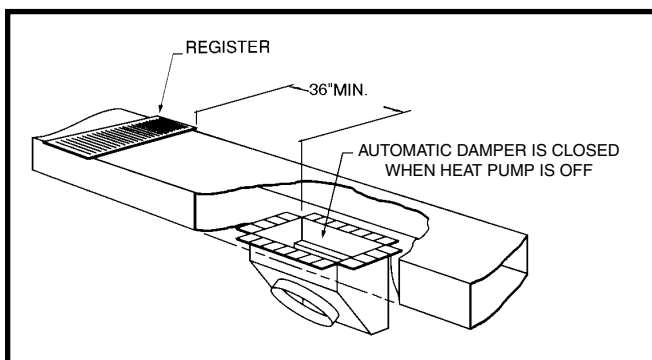

Figure 5. Supply Damper

Condensate Drainage

A 3/4" condensate fitting extends out of the side of the unit as shown in Figure 6. The drain trap, shipped in the electrical compartment, must be installed to prevent water from collecting inside the unit.

1. Thread the elbow provided with the unit into the drain connection until hand tight.
2. Connect the condensate tubing onto the fitting, forming a trap (Figure 6) near the drain connection.
3. Route the condensate tube from the trap to a suitable drain. **NOTE:** For proper drainage, make sure the trap is level to the ground and tubing outlet is below trap level.

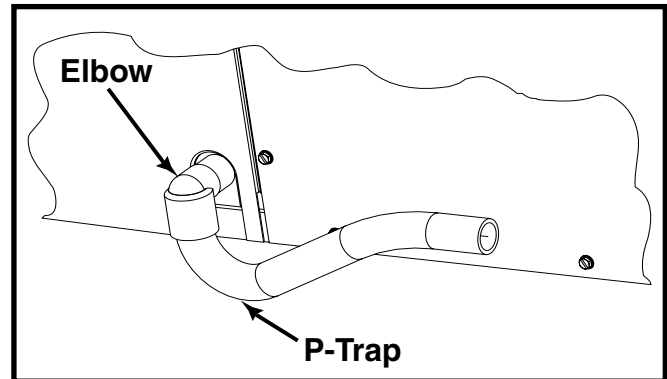

Figure 6. Drain Trap

ELECTRICAL CONNECTIONS

⚠ WARNING:

To avoid electric shock, personal injury, or death, turn off the electric power at the disconnect or the main service panel before making any electrical connections.

- Electrical connections must be in compliance with all applicable local codes and ordinances, and with the current revision of the National Electric Code (ANSI/NFPA 70).
- For Canadian installations the electrical connections and grounding shall comply with the current Canadian Electrical Code (CSA C22.1 and/or local codes).

Pre-Electrical Checklist:

- ✓ Verify that the voltage, frequency, and phase of the supply source match the specifications on the unit rating plate.
- ✓ Verify that the service provided by the utility is sufficient to handle the additional load imposed by this equipment. Refer to the unit wiring label for proper high and low voltage wiring.
- ✓ Verify factory wiring is in accordance with the unit wiring diagram (Figures 10 & 11, pages 21 & 22). Inspect for loose connections.

Line Voltage

- It is recommended that the line voltage to the unit be supplied from a dedicated branch circuit containing the correct fuse or circuit breaker for the unit.
- **An electrical disconnect must be located within sight of and readily accessible to the unit.** This switch shall

be capable of electrically de-energizing the outdoor unit. See unit data label for proper incoming field wiring. Any other wiring methods must be acceptable to authority having jurisdiction.

- Provide power supply for the unit in accordance with the unit wiring diagram, and the unit rating plate.
- Connect the line-voltage leads to the terminals on the contactor inside the control compartment. Extend leads through power wiring hole (Figure 7). Connect **L1 & L2** directly to the contactor.
- Use only copper wire for the line voltage power supply to this unit as listed in Table 1. Use proper code agency listed conduit and a conduit connector for connecting the supply wires to the unit. Use of rain tight conduit is recommended.
- See the unit wiring label for proper high and low voltage wiring. Make all electrical connections in accordance with all applicable codes and ordinances. See Figures 10 & 11 (pages 21 & 22).

⚠ CAUTION:

Label all wires prior to disconnection when servicing controls. Wiring errors can cause improper and dangerous operation. Verify proper operation after servicing.

Supply Wire Length (Feet)				Supply Circuit Ampacity
200	150	100	50	
6	8	10	14	15
4	6	8	12	20
4	6	8	10	25
4	4	6	10	30
3	4	6	8	35
3	4	6	8	40
2	3	4	6	45
2	3	4	6	50
2	3	4	6	55
1	2	3	4	60

Wire Size based on N.E.C. for 60° type copper conductors.

Table 1. Copper Wire Size AWG (1% voltage drop)

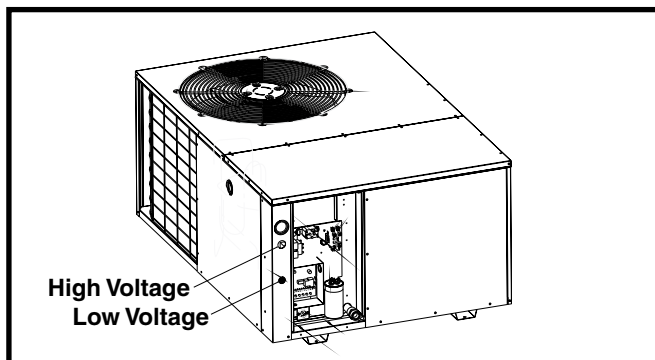

Figure 8. Power Entry

- Units are shipped from the factory wired for 240 volt transformer operation. For 208V operation, remove the lead from the transformer terminal marked 240V and connect it to the terminal marked 208V.

Overcurrent Protection

Overcurrent protection must be provided at the branch circuit distribution panel and sized as shown on the unit rating label and according to applicable local codes. Generally, the best fuse or breaker for any heat pump is the smallest size that will permit the equipment to run under normal usage and provide maximum equipment protection. Properly sized fuses and breakers also prevent nuisance trips during unit startup. **If a fuse blows or a breaker trips, always determine the reason. Do not arbitrarily install a larger fuse or breaker and do not, in any case, exceed the maximum size listed on the data label of the unit.**

Grounding

⚠ WARNING:

The unit cabinet must have an uninterrupted or unbroken electrical ground to minimize personal injury if an electrical fault should occur. Do not use gas piping as an electrical ground!

This unit must be electrically grounded in accordance with local codes or, in the absence of local codes, with the National Electrical Code (ANSI/NFPA 70) or the CSA C22.1 Electrical Code. Use the grounding lug provided in the control box for grounding the unit.

Thermostat Connections

- The heat-cool thermostat is equipped with a system HEAT-COOL switch, which provides a positive means of preventing simultaneous operation of the heating and cooling units. The thermostat is also equipped with an ON-AUTO fan switch which allows the home owner to operate the indoor blower when air circulation is desired.
- Connect the low voltage wires to the respective terminals on the thermostat base (Figure 12, page 23). See thermostat instruction sheet for more detailed wiring information.
- The thermostat should be mounted about 5 feet above the floor on an inside wall. **DO NOT** install the thermostat on an outside wall or any other location where its operation may be adversely affected by radiant heat from fireplaces, sunlight, or lighting fixtures, and convective heat from warm air registers or electrical appliances. Refer to the thermostat manufacturer's instruction sheet for detailed mounting information.

Defrost Cycle Control

The defrost cycle is initiated via a signal from the defrost sensor on the outdoor coil to the defrost control board inside the control panel. This indicates the coil temperature is low enough to start accumulating frost. The board has interval settings of 30, 60, and 90 minutes. These time intervals

represent the time elapsed before defrosting cycle starts and they are dependent on the climate conditions of the installation. A 30 minute setting would be recommended in a moist climate such as Seattle Washington. A 90 minute setting would be adequate in a dry climate such as southern Arizona. The factory time interval setting is 30 minutes.

Defrost Control Board

Operational Information

- Terminals **R - C** must have 24V present between them for the time delay and defrost sequences to be operational.
- **Defrost Thermostat (DFT) By-Pass** - Jumping the **T2 & DFT** test pins will communicate to the board that the defrost thermostat is closed (if the compressor is running). The defrost T-stat tells the board whether a defrost cycle needs to be started or terminated.

NOTE: The defrost T-stat is closed at 30° F or below and is open at 68° F or above, but its state is unknown if the temperature is between 30° F and 68° F.

- With the DFT closed, the unit will run for 30/60/90 minutes in heat mode and then defrost the outdoor coil. The defrost will turn off the outdoor fan, energize the reversing valve, and turn on the compressor raising the coil temperature to 68° F. This will open the DFT and terminate the defrost. If the DFT does not open, the defrost will end after 10 minutes.
- **Defrost Board Speed Up** - Jumping the **TEST** terminal to the **C** (common) terminal (while the compressor is in heat mode) will over-ride the defrost board and initiate a faster defrost test in 5, 10 or 15 seconds as determined by the 30, 60 or 90 minute defrost pin settings (factory setting is 30 minutes).
 - The compressor off delay is also bypassed when the unit goes into defrost test. If unit is kept in defrost test, the delay will be bypassed when the test is terminated by the processor.

NOTE: If the jumper is removed before the test is over, the processor will perform the remainder of a normal defrost as noted above.

- The delay/no-delay pin affects compressor operation during defrosts. The default setting is delay. To switch from delay to no-delay, remove the pin from the **delay** pin location and move it to the **no-delay** pin location.
 - Scroll compressors that have noise issues while going into or coming out of defrost should use this 30 second delay to reduce the defrost noise.

Normal Mode

To test normal defrost operation when the temperature is above 35° F, jumper **R** to **DFT** on the board and allow the unit to run for 30 minutes. Defrost will continue until the **R** to **DFT** jumper is removed or for 10 minutes. Remove the jumper.

The 5 minute time delay feature can be shortened 1 time to 1 second by jumping the **Test** to **C** terminal. Remove the jumper and repeat as desired. **NOTE:** If jumper is left on the **Test** to **common** pins permanently, the defrost cycle will be inoperable.

Speed Up Mode (Testing Procedure)

1. Jumper **T2** to **DFT** at the test terminals.
2. With unit running in heat mode, jump the **TEST** terminal to the **C** (common) terminal near it. The board will speed up and enter defrost mode in 5/10/15 seconds, depending on the defrost time selection. Compressor delay will not function during speed-up. **NOTE:** Manually initiating a defrost will cause the compressor to run continually when entering defrost.
3. This test will end in 5 seconds if the **TEST** - common short is not removed.
4. Remove both the short and the **T2** to **DFT** jumper to terminate the defrost cycle. The 30 second compressor delay should operate normally.
5. Test is complete, reset thermostat to the equipment owner's preference.

Electric Heat Package (optional)

This heat pump is shipped without an auxiliary electric heat kit installed. If electric heat is desired, an accessory heater kit must be field installed. Refer to Table 2 (page 10) for blower speeds.

- Select the correct size heat package for the installation. See specifications sheet for available kits and application. Install the heater kit according to the to the installation instructions provided with the kit.
- Installation is most easily accomplished before making duct or electrical connections.

Outdoor Thermostat (Factory Option)

The outdoor thermostat prevents the electrical auxiliary heat (if used) from operating above a desired set point. The factory temperature setting is 40° F.

Blower Speed

For optimum system performance and comfort, it may be necessary to change the factory speed setting. See Table 2 for factory settings.

WARNING:

To avoid electric shock, personal injury, or death, turn off the electric power at the disconnect or the main service panel before making any electrical connections.

CAUTION:

Label all wires prior to disconnection when servicing controls. Wiring errors can cause improper and dangerous operation. Verify proper operation after servicing.

CAUTION:

To avoid personal injury or property damage, make certain that the motor leads cannot come into contact with any metal components of the unit.

1. Disconnect all electrical power to the unit and remove the service panel.
2. Verify the required speed from the airflow data found in Table 2. Place appropriate wire on the appropriate motor speed tap for the required airflow.
3. Check all factory wiring per the unit wiring diagram and inspect the factory wiring connections make sure no wires loosened during shipping or installation.

Model Number	Motor Tap	External Static Pressure Drop (in WC)							
		0.1	0.2	0.3	0.4	0.5	0.6	0.7	0.8
024K	LOW	607	555	490	437	368	291	225	
	MED***	899	854	802	743	670	601	533	
	HIGH	1220	1178	1133	1091	1024	946	844	743
030K	LOW	847	808	770	726	664	562	460	
	HIGH***	1104	1114	1064	1010	935	846	710	536
036K	T1	1100	900	750	650	580	520	480	455
	T2**	1208	1080	1025	972	926	874	813	752
	T3*	1262	1199	1153	1110	1070	1027	965	906
	T4	1370	1333	1300	1260	1230	1180	1070	1010
	T5	1410	1340	1450	1320	1280	1240	1195	1150
036KA	LOW*	1318	1284	1248	1207	1160	1110	1043	957
	HIGH	1551	1521	1477	1434	1388	1342	1263	1180
042K	T1	1480	1455	1415	1390	1355	1320	1290	1255
	T2*	1575	1545	1515	1475	1440	1420	1385	1345
	T3**	1635	1505	1575	1545	1515	1485	1455	1425
	T4	1775	1740	1715	1695	1665	1635	1610	1580
	T5	2065	2040	2020	1985	1960	1940	1905	1850
048K	T1	1480	1455	1415	1390	1355	1320	1290	1255
	T2**	1575	1545	1515	1475	1440	1420	1385	1345
	T3*	1635	1505	1575	1545	1515	1485	1455	1425
	T4	1775	1740	1715	1695	1665	1635	1610	1580
	T5	2065	2040	2020	1985	1960	1940	1905	1850
048KA	LOW	1460	1440	1420	1390	1360	1325	1285	1235
	MED***	1840	1815	1790	1760	1715	1660	1605	1535
	HIGH	2155	2115	2065	2020	1955	1895	1830	1740
060K	T1	1370	1340	1310	1280	1260	1230	1195	1160
	T2	1470	1440	1410	1380	1360	1320	1290	1250
	T3**	1550	1520	1480	1450	1430	1400	1380	1350
	T4*	1810	1770	1740	1720	1690	1660	1610	1575
	T5	1890	1870	1840	1820	1800	1770	1710	1670

NOTES:

- * Denotes factory set cooling speed
- ** Denotes factory set electric heating speed
- *** Denotes factory set heating & cooling speed

Airflow performance is with a dry coil.

Table 2. Airflow Data

STARTUP & ADJUSTMENTS

Pre-Start Checklist

The following check list should be observed prior to starting the unit.

- √ Is the unit level? Unit should be level or slightly slanted toward the drain for proper condensate drainage.
- √ Is the unit installed with the proper clearances as listed on pages 4 - 5?
- √ Is the wiring correct according to the wiring diagram and electrical codes?
- √ Are all the wiring connections tight? Check the condenser fan to make sure it turns freely.
- √ Is the overcurrent protection properly sized?
- √ Is the thermostat wired correctly? Is it installed in a proper location?

Start-Up Procedure

The control circuit consists of an anti-short cycle timer that will not let the compressor re-start before 5 minutes have elapsed.

1. Set the system mode to OFF and the temperature mode to its highest setting.
2. Turn power on at the disconnect switch.
3. Set the system mode to ON or COOL.
4. Set the temperature mode below room temperature. Verify that the indoor blower, outdoor fan, and compressor energize and the cooling function starts.
5. Verify the discharge air grilles are adjusted and the system air is balanced.
6. Verify the duct work has no air leaks.
7. Verify the condensate drain is installed correctly and functions properly.
8. Set the temperature mode above room temperature. The unit should stop.
9. Instruct the homeowner on unit and thermostat operation and filter servicing.

Air Circulation

Leave the thermostat system mode on OFF, and set the fan mode to ON. Blower should run continuously. Check the air delivery at the supply registers and adjust register openings for balanced air distribution. Examine ducts for leaks or obstruction if insufficient air is detected.

Set the thermostat fan mode to AUTO. The blower should stop running.

System Heating

Set the thermostat system mode to HEAT and the fan mode to AUTO. Change the thermostat temperature selector above the existing room temperature and check for the discharge of warm air at the supply registers.

System Cooling

Set the thermostat's system mode to COOL and the fan mode to AUTO. Change the thermostat temperature selector below the existing room temperature. Allow the cooling system to operate for several minutes and check for the discharge of cool air at the supply registers.

Short Cycle Protection

The control circuit is equipped with a time-delay feature for protection against short cycling. With the system operating in the cooling mode, gradually raise the thermostat temperature setting until the whole system de-energizes. Immediately lower the thermostat temperature to the original setting and verify that the indoor blower is energized. After approximately 5 minutes the compressor and the outdoor fan will energize.

Emergency Heat

(Available only when Electric heat is supplied) Set the thermostat's system mode to EM HT and the fan mode to either AUTO (intermittent air) or to ON (continuous air). Change the thermostat's temperature selector above the existing room temperature and check the following:

1. The thermostat auxiliary heat light (RED) should be on.
2. The heat pump compressor and the fan should not run; low voltage circuit remains energized.
3. The blower will run according to the thermostat's fan mode setting.

Anti Short Cycle Timer Test

The 5 minute time delay feature can be bypassed by shorting the TEST pins together.

Heating Mode

When the TEST pins are shorted together for more than 1 second, the control will switch between defrost mode and heating mode.

Cooling Mode

When the TEST pins are shorted together for more than 1 second, the Anti Short Cycle Timer will be bypassed.

Adjustment of Refrigerant Charge

CAUTION:

This heat pump contains liquid and gaseous refrigerant under pressure. Adjustment of refrigerant charge should only be attempted by qualified, trained personnel thoroughly familiar with the equipment and safe responsible refrigerant handling procedures. Under no circumstances should the homeowner attempt to install and/or service this equipment. Failure to comply with this warning could result in equipment damage, personal injury, or death.

- The unit must be charged while both first and second stages are operating.
- To achieve rated capacity and efficiency the compressor must be exposed to refrigerant for at least 24 hours prior to running and then must be run for a minimum of 12 hours.

Charging the Unit in AC Mode with Outdoor Temperatures Above 65° F

1. With the system operating at steady-state, measure the liquid refrigerant pressure in psig at the service valve.
 2. Measure the liquid refrigerant temperature (° F) at the service valve.
 3. For the temperature measured, determine the required liquid refrigerant pressure from the appropriate charging charts. For cooling operation, see Tables 3 - 8 or Figure 9 (pages 14 - 16).
- If the pressure measured in step 1 is greater than the required liquid refrigerant pressure determined in step 3, then there is too much charge in the system. Remove refrigerant and repeat steps 1 through 3 until the system is correctly charged.
 - If the pressure measured in step 1 is less than the required liquid refrigerant pressure determined in step 3, then there is too little charge in the system. Add refrigerant and repeat steps 1 through 3 until the system is correctly charged.

Charging the Unit in Heating Mode

1. Evacuate the refrigerant system.
2. Weigh in the proper charge as shown on the unit rating plate. Use the charging charts for heating mode of operation as a guide (Tables 9 - 15, pages 17 - 20). Tables reflect conditions at high speed operation. Unit charge **MUST** be verified in cooling season.
3. Verify the unit is operating properly according to the System Heating section on page 11.

UNIT MAINTENANCE

WARNING:

To prevent electrical shock, personal injury, or death, disconnect all electrical power to the unit before performing any maintenance or service. The unit may have more than one electrical supply.

Proper maintenance is important to achieve optimum performance from the heat pump. The ability to properly perform maintenance on this equipment requires certain mechanical skills and tools. If you do not possess these skills, contact your dealer for maintenance. Consult your local dealer about the availability of maintenance contracts. Routine maintenance should include the following:

- Inspect and clean or replace air filters at the beginning of each heating and cooling season, or more frequently if required.
- Inspect the condensate drain and outdoor coil at the beginning of each cooling season. Remove any debris. Clean the outdoor coil and louvers as necessary using a mild detergent and water. Rinse thoroughly with water.
- Inspect the electrical connections for tightness at the beginning of each heating and cooling season. Service as necessary.

CAUTION:

The unit should never be operated without a filter in the return air system. Replace disposable filters with the same type and size.

- Do not attempt to add additional oil to motors unequipped with oil tubes. The compressor is hermetically sealed at the factory and does not require lubrication.

COMPONENT FUNCTIONS

Low Pressure Switch - This switch is factory installed and located in the suction line internal to the unit. The switch is designed to protect the compressor if a loss of charge occurs. Under normal conditions, the switch is closed.

If the suction pressure falls below 5 psig, then the switch will open and de-energize the unit. The switch will close again once the suction pressure increases above 20 psig. The low pressure switch interrupts the thermostat inputs to the unit. **NOTE:** When the switch opens and then closes, there will be a 5 minute short cycling delay before the unit can energize.

High Pressure Switch - This switch is factory installed and located in the compressor discharge line internal to the unit. The switch is designed to de-energize the system when very high pressures occur during abnormal conditions. Under normal conditions, the switch is closed.

If the discharge pressure rises above 650 psig, the switch will open and de-energize the unit. The switch will close again once the discharge pressure decreases to 460 psig. The high pressure switch interrupts the thermostat inputs to the unit. **NOTE:** When the switch opens and then closes, there will be a 5 minute short cycling delay before the unit can energize.

FIGURES & TABLES

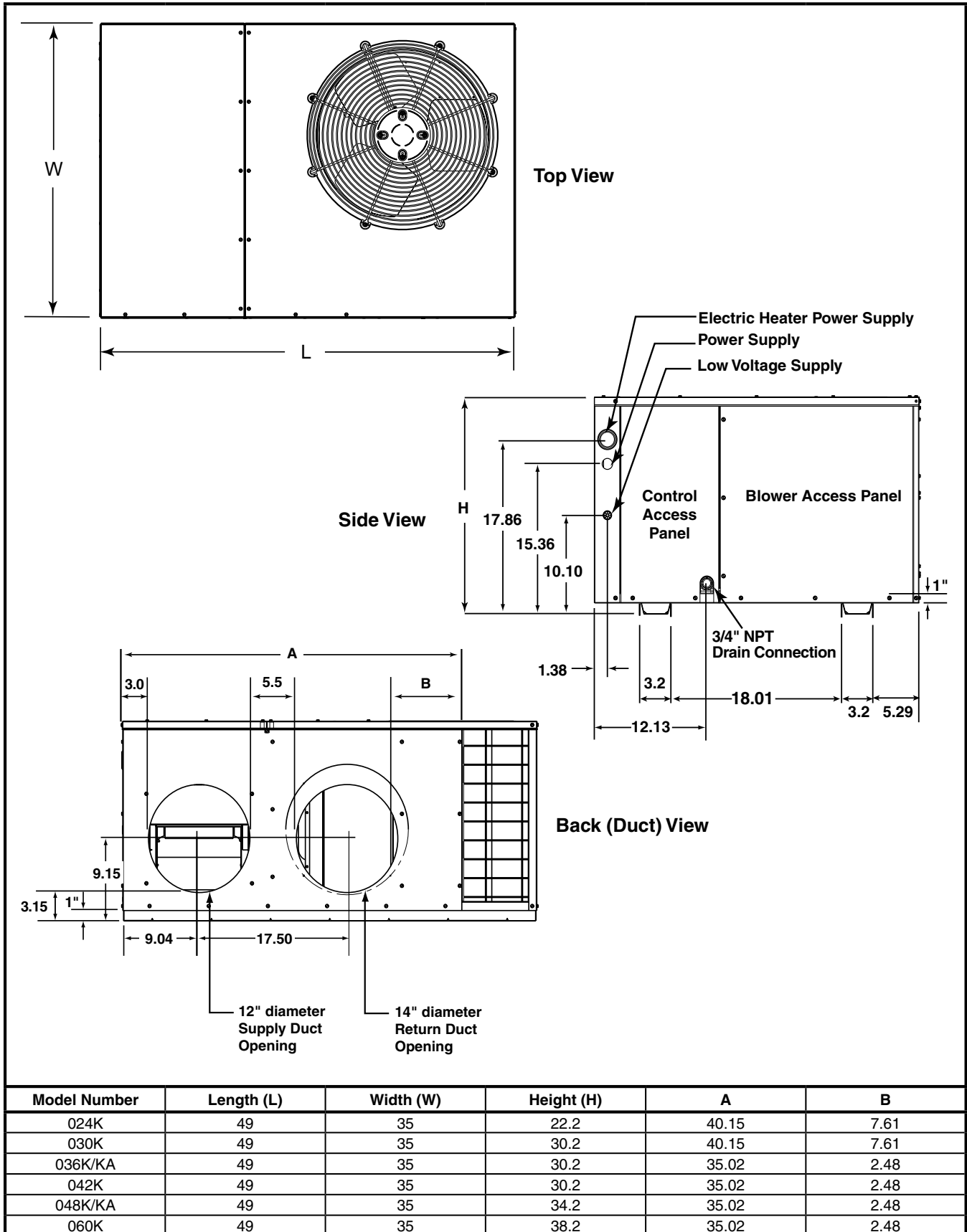



Figure 8. Physical Data & Unit Dimensions

REFRIGERANT CHARGING TABLES - COOLING MODE

 Shaded boxes indicate flooded conditions.

 Rated design values. The suction pressure will be lower than design value if indoor air flow, entering dry bulb, or entering wet bulb temperature are lower than design.

1. All pressures are listed psig and all temperatures in °F
2. Discharge temperatures greater than charted values indicate an undercharged system.

2 TON MODELS																
SUCT. PRESS.	OUTDOOR TEMPERATURE (° F)															
	70		75		80		85		90		95		100		105	
	Liq. PRESS.	Dis. TEMP.	Liq. PRESS.	Dis. TEMP.	Liq. PRESS.	Dis. TEMP.	Liq. PRESS.	Dis. TEMP.	Liq. PRESS.	Dis. TEMP.	Liq. PRESS.	Dis. TEMP.	Liq. PRESS.	Dis. TEMP.	Liq. PRESS.	Dis. TEMP.
136	260	136														
138	262	142	283	140												
140	265	147	285	145	306	143										
142	270	146	288	150	309	148	330	147								
144	274	148	293	150	311	153	332	152	353	151						
146			296	154	315	155	334	156	355	155	376	155				
148					319	158	338	159	357	160	378	159	399	159		
150							342	163	361	163	380	163	401	163	422	163
152							345	167	364	167	383	167	403	167	424	167
154									368	171	387	171	406	171	426	170
156											390	175	410	175	429	175
158													413	179	432	179
160															436	183
162																

Table 3. Charging Table for 2 Ton Models (024K Series)

2.5 TON MODELS																
SUCT. PRESS.	OUTDOOR TEMPERATURE (° F)															
	70		75		80		85		90		95		100		105	
	Liq. PRESS.	Dis. TEMP.	Liq. PRESS.	Dis. TEMP.	Liq. PRESS.	Dis. TEMP.	Liq. PRESS.	Dis. TEMP.	Liq. PRESS.	Dis. TEMP.	Liq. PRESS.	Dis. TEMP.	Liq. PRESS.	Dis. TEMP.	Liq. PRESS.	Dis. TEMP.
139	258	115														
141	260	121	281	121												
143	262	126	283	126	304	126										
145	266	129	285	131	306	131	327	132								
147	269	131	289	134	308	136	329	136	350	137						
149			292	137	312	139	331	141	352	142	373	143				
151					315	143	334	145	354	146	375	147	396	148		
153							338	148	357	150	377	151	398	152	419	154
155							341	152	361	154	380	155	400	156	421	157
157									364	158	384	159	403	161	423	161
159											387	163	407	165	426	166
161													410	169	430	170
163															433	175
165																

Table 4. Charging Table for 2.5 Ton Models (030K Series)

3 TON MODELS (WITH ECM MOTOR)																	
SUCT. PRESS.	OUTDOOR TEMPERATURE (° F)																
	70		75		80		85		90		95		100		105		
	Liq. PRESS.	Dis. TEMP.	Liq. PRESS.	Dis. TEMP.	Liq. PRESS.	Dis. TEMP.	Liq. PRESS.	Dis. TEMP.	Liq. PRESS.	Dis. TEMP.	Liq. PRESS.	Dis. TEMP.	Liq. PRESS.	Dis. TEMP.	Liq. PRESS.	Dis. TEMP.	
138	267	113															
140	269	118	290	119													
142	271	123	292	124	314	125											
144	272	131	294	129	316	130	337	131									
146	276	133	296	135	318	135	339	136	360	137							
148			300	138	320	140	341	141	362	142	384	143					
150					323	143	344	145	364	146	386	147	407	148			
152							347	148	367	150	388	151	409	152	430	154	
154							351	152	371	154	391	155	411	156	432	157	
156									374	158	395	159	415	161	434	161	
158											398	163	418	165	439	166	
160													422	169	442	171	
162															445	175	
164																	

3 TON MODELS (WITH PSC MOTOR)																	
135	258	119															
137	260	125	282	125													
139	262	130	284	130	305	131											
141	265	134	286	135	308	135	329	136									
143	269	136	289	139	310	140	331	141	353	142							
145			293	142	313	144	333	145	355	146	377	147					
147					316	147	337	149	357	150	379	151	401	152			
149							340	153	361	154	391	155	403	156	424	158	
151							344	156	364	158	384	159	405	160	426	162	
153									367	162	388	164	408	165	428	165	
155											391	168	412	169	432	170	
157													415	173	435	174	
159															439	179	
161																	

Table 5. Charging Table for 3 Ton Models (036K / 036KA Series)

3.5 TON MODELS																	
SUCT. PRESS.	OUTDOOR TEMPERATURE (° F)																
	70		75		80		85		90		95		100		105		
	Liq. PRESS.	Dis. TEMP.	Liq. PRESS.	Dis. TEMP.	Liq. PRESS.	Dis. TEMP.	Liq. PRESS.	Dis. TEMP.	Liq. PRESS.	Dis. TEMP.	Liq. PRESS.	Dis. TEMP.	Liq. PRESS.	Dis. TEMP.	Liq. PRESS.	Dis. TEMP.	
134	269	129															
136	271	135	293	134													
138	274	140	295	139	316	138											
140	279	139	297	144	318	143	340	143									
142	282	142	302	145	320	148	342	148	363	148							
144			305	148	325	150	344	152	365	152	387	153					
146					328	154	348	155	367	156	389	157	410	157			
148							351	159	371	160	391	161	412	161	434	162	
150							355	163	374	164	394	165	414	165	436	166	
152									378	168	398	169	417	170	438	170	
154											401	173	421	174	440	174	
156													424	178	444	179	
158															447	183	
160																	

Table 6. Charging Table for 3.5 Ton Models (042K Series)

4 TON MODELS (WITH RESTRICTOR)																
SUCT. PRESS.	OUTDOOR TEMPERATURE (° F)															
	70		75		80		85		90		95		100		105	
	Liq. PRESS.	Dis. TEMP.	Liq. PRESS.	Dis. TEMP.	Liq. PRESS.	Dis. TEMP.	Liq. PRESS.	Dis. TEMP.	Liq. PRESS.	Dis. TEMP.	Liq. PRESS.	Dis. TEMP.	Liq. PRESS.	Dis. TEMP.	Liq. PRESS.	Dis. TEMP.
133	280	143														
135	282	149	305	147												
137	285	154	307	152	330	151										
139	290	153	309	157	332	156	355	155								
141	293	156	314	158	334	160	357	159	380	158						
143			318	161	339	163	359	164	382	163	405	163				
145					342	166	363	167	384	167	407	167	430	167		
147							367	170	388	171	409	171	432	171	455	171
149							370	174	391	175	412	175	434	175	457	175
151									395	179	416	179	437	179	459	178
153											419	183	440	183	461	183
155													444	187	465	187
157															468	191
159																

Table 7. Charging Table for 4 Ton Models (048K Series)

4 Ton Models With TXV (048KA Series)

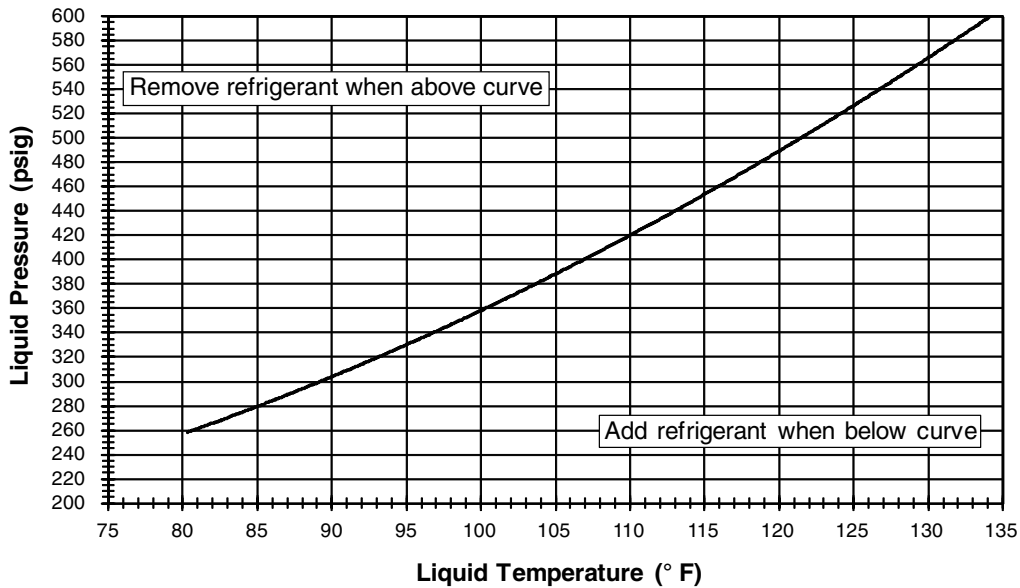

Figure 9. Charging Chart for 4 Ton Models with TXV (048KA Series)

5 TON MODELS																
SUCT. PRESS.	OUTDOOR TEMPERATURE (° F)															
	70		75		80		85		90		95		100		105	
	Liq. PRESS.	Dis. TEMP.	Liq. PRESS.	Dis. TEMP.	Liq. PRESS.	Dis. TEMP.	Liq. PRESS.	Dis. TEMP.	Liq. PRESS.	Dis. TEMP.	Liq. PRESS.	Dis. TEMP.	Liq. PRESS.	Dis. TEMP.	Liq. PRESS.	Dis. TEMP.
124																
126	274	101														
128	276	112	295	111												
130	277	124	298	121	318	119										
132	279	129	300	131	320	128	340	128	360	130						
134	280	146	303	136	326	128	344	134	363	137	383	136				
136			304	150	327	141	350	133	367	145	387	142	406	141		
138					329	155	352	145	374	145	391	149	410	148	430	148
140							354	159	376	153	398	148	415	154	434	153
142									378	164	401	158	423	153	439	159
144											403	168	425	163	447	158
146													428	172	450	167
148															452	176
150																

Table 8. Charging Table for 5 Ton Models (060K Series)

REFRIGERANT CHARGING TABLES - HEATING MODE

Shaded boxes indicate flooded conditions.

Rated design values. Suction pressure will vary from design value if outdoor air flow, entering dry bulb, or entering wet bulb temperatures vary.

1. All pressures are listed psig and all temperatures in °F

2. Discharge temperatures greater than charted values indicate an undercharged system.

2 TON MODELS																					
OUTDOOR TEMPERATURE (° F)																					
Suc. Press.	0			10			20			30			40			50			60		
	Liq. Press.	Dis. Temp.	Suc. Press.	Liq. Press.	Dis. Temp.	Suc. Press.	Liq. Press.	Dis. Temp.	Suc. Press.	Liq. Press.	Dis. Temp.	Suc. Press.	Liq. Press.	Dis. Temp.	Suc. Press.	Liq. Press.	Dis. Temp.	Suc. Press.	Liq. Press.	Dis. Temp.	
37	209	114	51	232	121	65	254	127	78	277	133	94	292	142	110	322	154	127	353	165	
38	216	112	52	238	119	66	259	125	79	281	131	95	299	140	111	329	149	128	360	159	
39	223	110	53	244	117	67	264	123	80	284	129	96	306	137	112	336	145	129	367	153	
40	230	108	54	250	115	68	269	121	81	288	127	97	313	134	113	343	140	130	374	147	
41	237	106	55	255	113	69	274	119	82	292	125	98	320	131	114	350	136	131	381	140	
42	244	104	56	261	111	70	278	117	83	295	123	99	327	128	115	357	131	132	388	134	
43	251	102	57	267	109	71	283	115	84	299	121	100	334	125	116	364	127	133	395	128	

Table 9. Charging Table for 2 Ton Models (024K Series)

2.5 TON MODELS																					
OUTDOOR TEMPERATURE (° F)																					
Suc. Press.	0			10			20			30			40			50			60		
	Liq. Press.	Dis. Temp.	Suc. Press.	Liq. Press.	Dis. Temp.	Suc. Press.	Liq. Press.	Dis. Temp.	Suc. Press.	Liq. Press.	Dis. Temp.	Suc. Press.	Liq. Press.	Dis. Temp.	Suc. Press.	Liq. Press.	Dis. Temp.	Suc. Press.	Liq. Press.	Dis. Temp.	
47	226	137	55	235	134	62	245	130	69	254	126	85	260	131	109	286	143	134	313	155	
48	233	135	56	241	132	63	250	128	70	258	124	86	267	128	110	293	138	135	320	149	
49	240	133	57	247	130	64	254	126	71	262	122	87	274	125	111	300	134	136	327	143	
50	247	131	58	253	128	65	259	124	72	265	120	88	281	122	112	307	129	137	334	137	
51	254	129	59	259	126	66	264	122	73	269	118	89	288	119	113	314	125	138	341	130	
52	261	127	60	265	124	67	269	120	74	273	116	90	295	117	114	321	120	139	348	124	
53	268	125	61	271	122	68	274	118	75	276	114	91	302	114	115	328	116	140	355	118	

Table 10. Charging Table for 2.5 Ton Models (030K Series)

REFRIGERANT CHARGING TABLES - HEATING MODE

Shaded boxes indicate flooded conditions.

Rated design values. Suction pressure will vary from design value if outdoor air flow, entering dry bulb, or entering wet bulb temperatures vary.

1. All pressures are listed psig and all temperatures in °F

2. Discharge temperatures greater than charted values indicate an undercharged system.

3 TON MODELS																					
OUTDOOR TEMPERATURE (° F)																					
Suc. Press	0			10			20			30			40			50			60		
	Liq. Press.	Dis. Temp.	Suc. Press.	Liq. Press.	Dis. Temp.	Suc. Press.	Liq. Press.	Dis. Temp.	Suc. Press.	Liq. Press.	Dis. Temp.	Suc. Press.	Liq. Press.	Dis. Temp.	Suc. Press.	Liq. Press.	Dis. Temp.	Suc. Press.	Liq. Press.	Dis. Temp.	
34	216	127	49	234	128	63	251	129	78	269	130	93	275	135	109	294	145	124	313	154	
35	223	125	50	240	126	64	256	127	79	272	128	94	282	133	110	301	140	125	320	148	
36	230	123	51	246	124	65	261	125	80	276	126	95	289	130	111	308	136	126	327	142	
37	237	121	52	251	122	66	266	123	81	280	124	96	296	127	112	315	131	127	334	136	
38	244	119	53	257	120	67	270	121	82	283	122	97	303	124	113	322	127	128	341	129	
39	251	117	54	263	118	68	275	119	83	287	120	98	310	121	114	329	122	129	348	123	
40	258	115	55	269	116	69	280	117	84	291	118	99	317	118	115	336	118	130	355	117	
3 TON MODELS (KA SERIES)																					
OUTDOOR TEMPERATURE (° F)																					
Suc. Press	0			10			20			30			40			50			60		
	Liq. Press.	Dis. Temp.	Suc. Press.	Liq. Press.	Dis. Temp.	Suc. Press.	Liq. Press.	Dis. Temp.	Suc. Press.	Liq. Press.	Dis. Temp.	Suc. Press.	Liq. Press.	Dis. Temp.	Suc. Press.	Liq. Press.	Dis. Temp.	Suc. Press.	Liq. Press.	Dis. Temp.	
32	216	129	47	234	130	62	252	131	76	270	132	92	278	137	108	297	147	124	317	157	
33	223	127	48	240	128	63	257	129	77	274	130	93	285	135	109	304	143	125	324	151	
34	230	125	49	246	126	64	262	127	78	278	128	94	292	132	110	311	138	126	331	145	
35	237	123	50	252	124	65	267	125	79	281	126	95	299	129	111	318	134	127	338	138	
36	244	121	51	258	122	66	271	123	80	285	124	96	306	126	112	325	129	128	345	132	
37	251	119	52	264	120	67	276	121	81	289	122	97	313	123	113	332	125	129	352	126	
38	258	117	53	269	118	68	281	119	82	292	120	98	320	120	114	339	120	130	359	120	

Table 11. Charging Table for 3 Ton Models (036K & KA Series)

REFRIGERANT CHARGING TABLES - HEATING MODE

Shaded boxes indicate flooded conditions.

Rated design values. Suction pressure will vary from design value if outdoor air flow, entering dry bulb, or entering wet bulb temperatures vary.

1. All pressures are listed psig and all temperatures in °F

2. Discharge temperatures greater than charted values indicate an undercharged system.

3.5 TON MODELS

OUTDOOR TEMPERATURE (° F)

0	10			20			30			40			50			60		
	Suc. Press.	Liq. Press.	Dis. Temp.	Suc. Press.	Liq. Press.	Dis. Temp.	Suc. Press.	Liq. Press.	Dis. Temp.	Suc. Press.	Liq. Press.	Dis. Temp.	Suc. Press.	Liq. Press.	Dis. Temp.	Suc. Press.	Liq. Press.	Dis. Temp.
33	217	136	137	63	261	138	78	283	139	92	295	144	107	319	154	121	343	163
34	224	134	135	64	266	136	79	287	137	93	302	141	108	326	149	122	350	157
35	231	132	133	65	271	134	80	290	135	94	309	139	109	333	145	123	357	151
36	238	130	131	66	275	132	81	294	133	95	316	136	110	340	140	124	364	145
37	245	128	129	67	280	130	82	298	131	96	323	133	111	347	136	125	371	139
38	252	126	127	68	285	128	83	301	129	97	330	130	112	354	131	126	378	133
39	259	124	125	69	290	126	84	305	127	98	337	127	113	361	127	127	385	126

Table 12. Charging Table for 3.5 Ton Models (042K Series)

4 TON MODELS

OUTDOOR TEMPERATURE (° F)

0	10			20			30			40			50			60		
	Suc. Press.	Liq. Press.	Dis. Temp.	Suc. Press.	Liq. Press.	Dis. Temp.	Suc. Press.	Liq. Press.	Dis. Temp.	Suc. Press.	Liq. Press.	Dis. Temp.	Suc. Press.	Liq. Press.	Dis. Temp.	Suc. Press.	Liq. Press.	Dis. Temp.
33	218	127	129	59	254	131	72	272	133	87	285	139	105	315	148	122	346	158
34	225	125	127	60	259	129	73	276	131	88	292	136	106	322	144	123	353	151
35	232	123	125	61	264	127	74	279	129	89	299	133	107	329	139	124	360	145
36	239	121	123	62	268	125	75	283	127	90	306	131	108	336	135	125	367	139
37	246	119	121	63	273	123	76	287	125	91	313	128	109	343	130	126	374	133
38	253	117	119	64	278	121	77	290	123	92	320	125	110	350	126	127	381	127
39	260	115	117	65	283	119	78	294	121	93	327	122	111	357	121	128	388	121

Table 13. Charging Table for 4 Ton Models (048K Series)

REFRIGERANT CHARGING TABLES - HEATING MODE

Shaded boxes indicate flooded conditions.

Rated design values. Suction pressure will vary from design value if outdoor air flow, entering dry bulb, or entering wet bulb temperatures vary.

1. All pressures are listed psig and all temperatures in °F

2. Discharge temperatures greater than charted values indicate an undercharged system.

4 TON MODELS (KA SERIES)

OUTDOOR TEMPERATURE (° F)

Suc. Press	0			10			20			30			40			50			60		
	Liq. Press.	Dis. Temp.	Suc. Press.	Liq. Press.	Dis. Temp.	Suc. Press.	Liq. Press.	Dis. Temp.	Suc. Press.	Liq. Press.	Dis. Temp.	Suc. Press.	Liq. Press.	Dis. Temp.	Suc. Press.	Liq. Press.	Dis. Temp.	Suc. Press.	Liq. Press.	Dis. Temp.	
33	218	137	47	236	137	60	254	137	74	273	137	89	284	142	106	311	151	123	338	161	
34	225	135	48	242	135	61	259	135	75	276	135	90	291	139	107	318	147	124	345	155	
35	232	133	49	248	133	62	264	133	76	280	133	91	298	136	108	325	142	125	352	148	
36	239	131	50	254	131	63	269	131	77	284	131	92	305	133	109	332	138	126	359	142	
37	246	129	51	260	129	64	274	129	78	287	129	93	312	131	110	339	133	127	366	136	
38	253	127	52	266	127	65	278	127	79	291	127	94	319	128	111	346	129	128	373	130	
39	260	125	53	271	125	66	283	125	80	295	125	95	326	125	112	357	124	129	380	124	

Table 14. Charging Table for 4 Ton Models (048KA Series)

5 TON MODELS

OUTDOOR TEMPERATURE (° F)

Suc. Press	0			10			20			30			40			50			60		
	Liq. Press.	Dis. Temp.	Suc. Press.	Liq. Press.	Dis. Temp.	Suc. Press.	Liq. Press.	Dis. Temp.	Suc. Press.	Liq. Press.	Dis. Temp.	Suc. Press.	Liq. Press.	Dis. Temp.	Suc. Press.	Liq. Press.	Dis. Temp.	Suc. Press.	Liq. Press.	Dis. Temp.	
31	203	134	44	233	139	57	264	143	70	294	148	84	313	162	100	344	186	116	375	210	
32	210	132	45	239	137	58	269	141	71	298	146	85	320	159	101	351	182	117	382	204	
33	217	130	46	245	135	59	273	139	72	302	144	86	327	156	102	358	177	118	389	198	
34	224	128	47	251	133	60	278	137	73	305	142	87	334	154	103	365	173	119	396	192	
35	231	126	48	257	131	61	283	135	74	309	140	88	341	151	104	372	168	120	403	186	
36	238	124	49	263	129	62	288	133	75	313	138	89	348	148	105	379	164	121	410	180	
37	245	122	50	269	127	63	293	131	76	316	136	90	355	145	106	386	159	122	417	173	

Table 15. Charging Table for 5 Ton Models (060K Series)

ELECTRICAL DIAGRAMS

WIRING DIAGRAM

SMALL PACKAGE HEAT PUMP Q5RD/GQ5RD/PPH2RD WITH PSC INDOOR MOTOR

208/230 VOLT

60HZ/SINGLE PHASE

1. Couper le courant avant de faire letrefine.
2. Employez uniquement des conducteurs en cuivre.
9. Ne convient pas aux installations de plus de 150V a la terre.

- NOTES:
1. Disconnect all power before servicing.
 2. For supply connections use copper conductors only.
 3. Not suitable on systems that exceed 150V to ground.

4. For replacement wires use conductors suitable for 105°C.

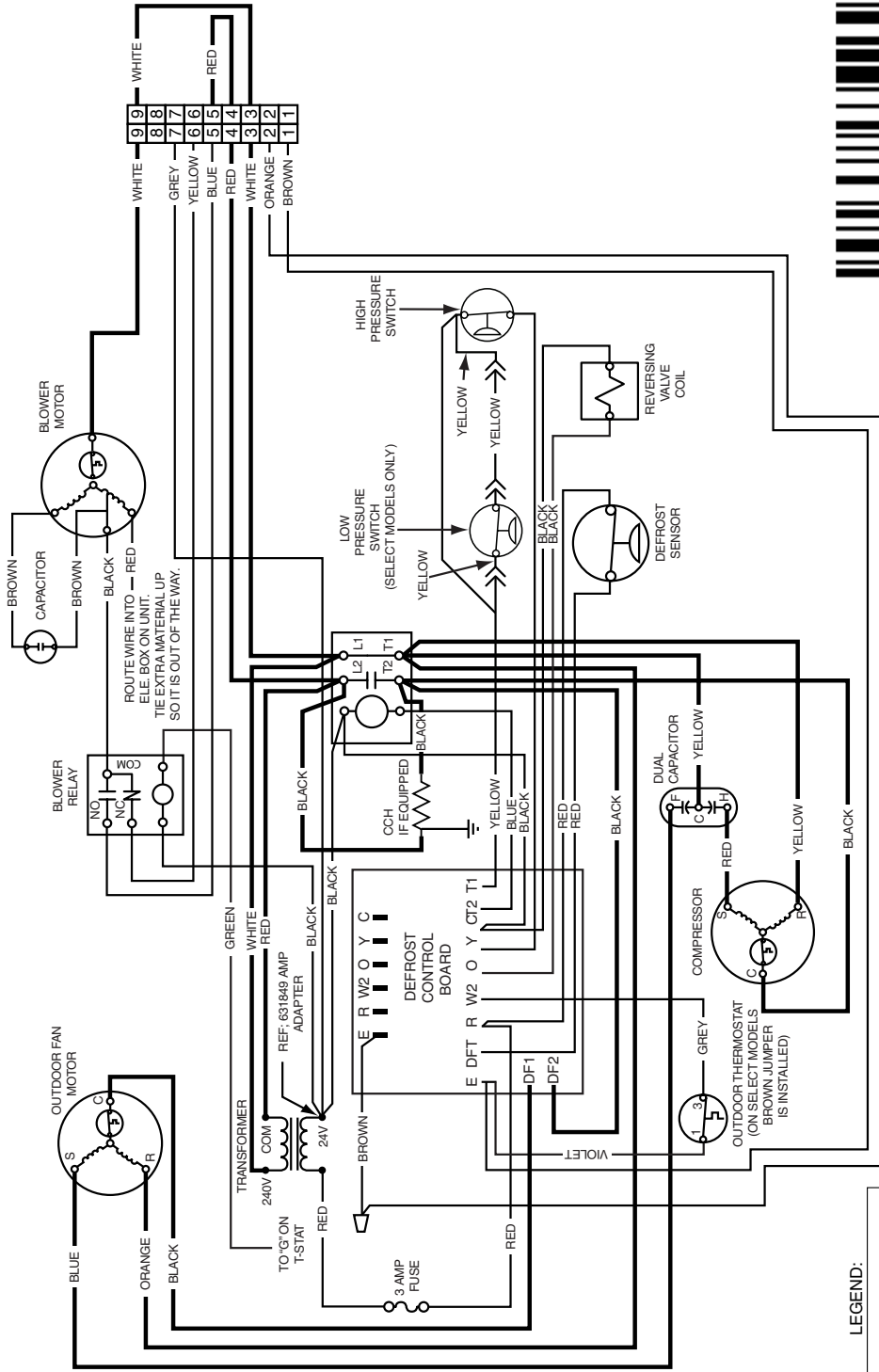

7111360
(Replaces 7108380)
09/10

Figure 10. Wiring Diagram - 2, 2.5, 3, & 4 Ton Models

WIRING DIAGRAM

3.5 & 5 TON PACKAGED HEAT PUMP- SINGLE PHASE 208/230 VOLT

60HZ

7. Couper le courant avant de faire le retrait.
8. Employez uniquement des conducteurs en cuivre.
9. Ne convient pas aux installations de plus de 150V a la terre.

4. For replacement wires use conductors suitable for 105° C.
5. On models w/no pressure switch, Yellow Jumper connects "Y" & "T1" on Defrost Board.

6. Disconnect all power before servicing.
7. For replacement wires use copper conductors suitable for 105° C.
8. On models w/no pressure switch, Yellow Jumper connects "Y" & "T1" on Defrost Board.
9. Do not use on systems that exceed 150V to ground.

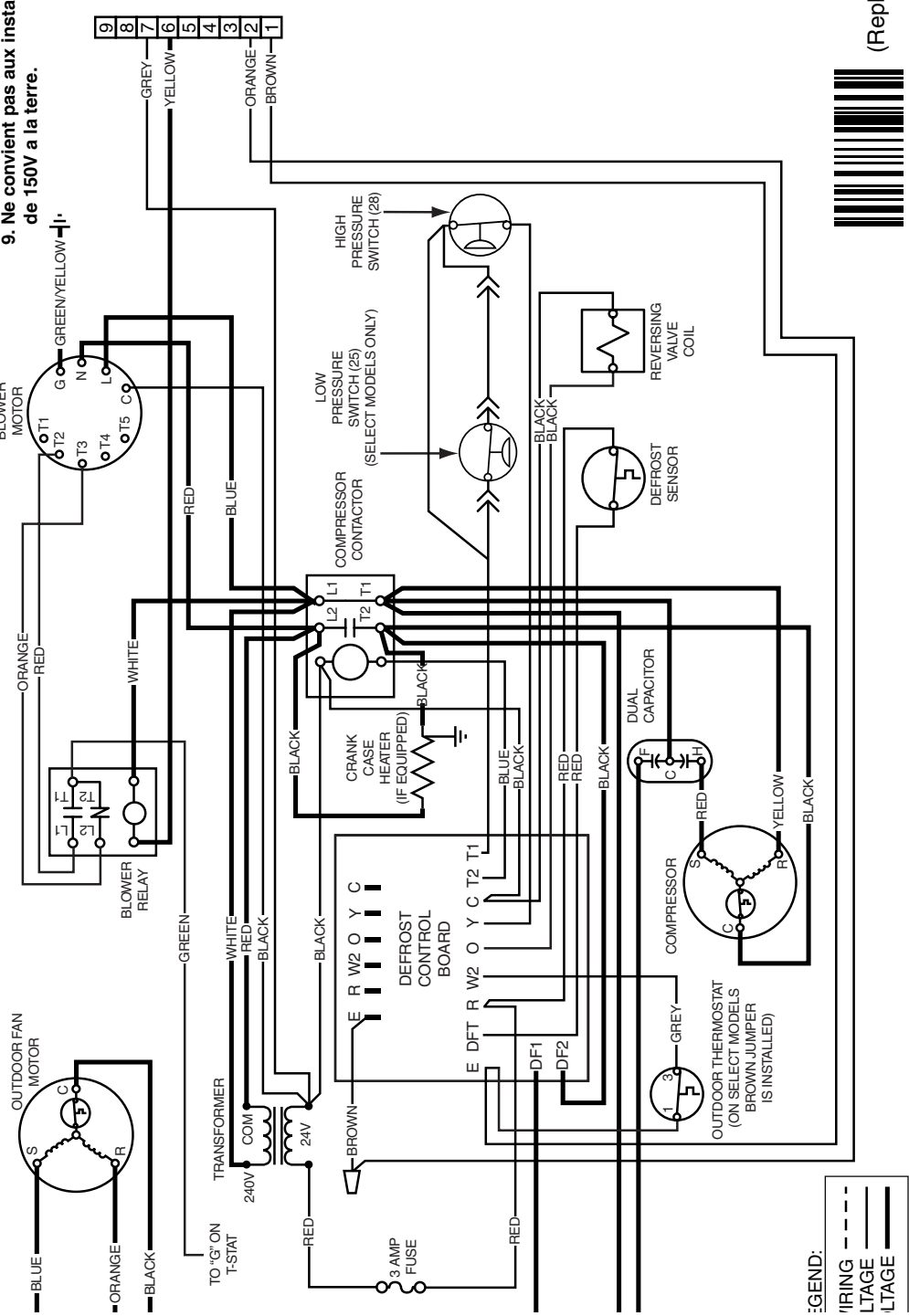

711135A
(Replaces 7111350)
10/12

Figure 11. Wiring Diagram - 3.5 & 5 Ton Models

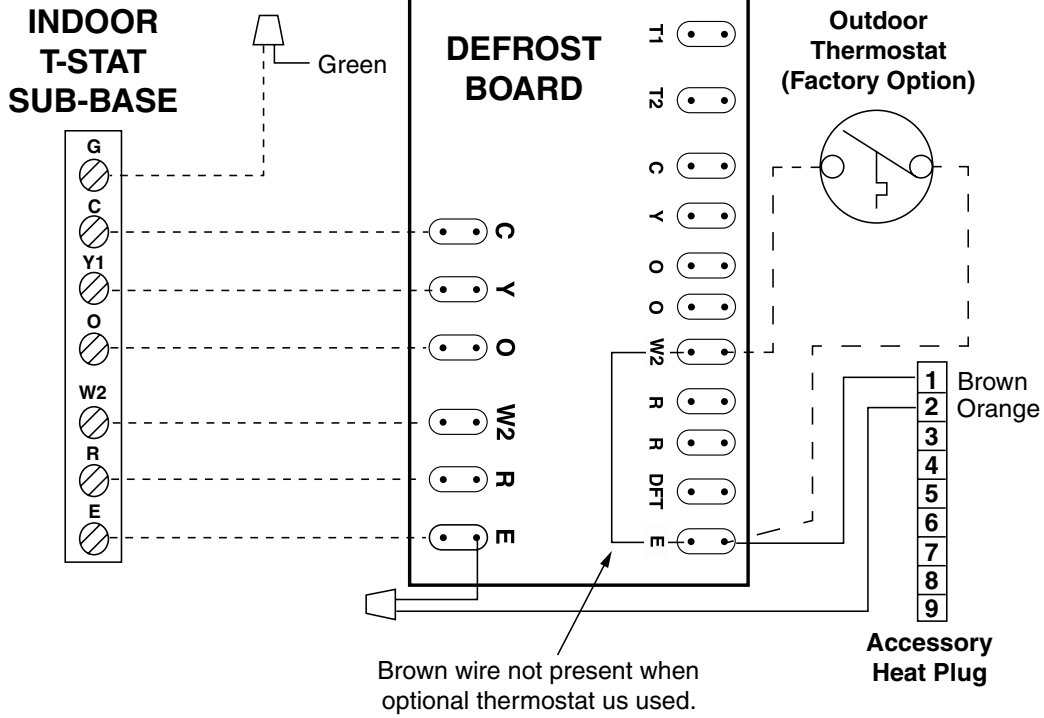

Typical Wiring (Field Supplied) for 1-Stage Cool, 1 Stage Electric Heat

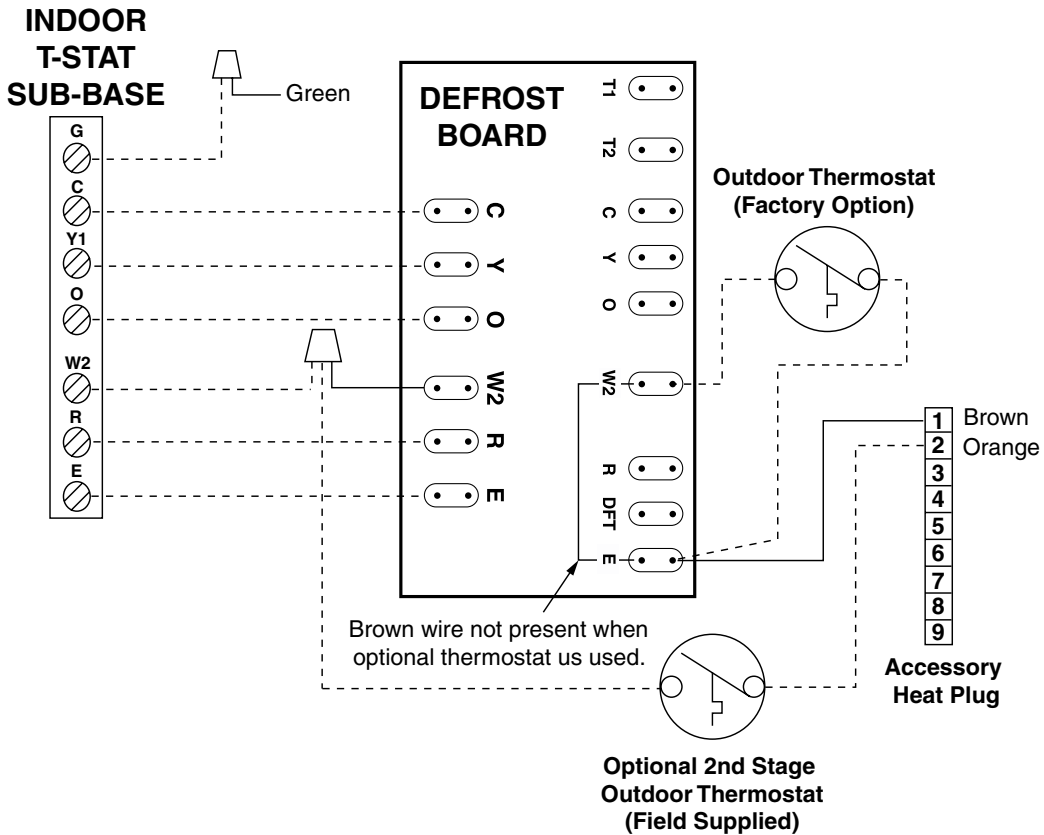

Typical Wiring (Field Supplied) for 1-Stage Cool, 2 Stage Electric Heat

Figure 12. Typical Thermostat Connections

INSTALLATION / PERFORMANCE CHECK LIST

INSTALLATION ADDRESS:		
CITY _____	STATE _____	
UNIT MODEL # _____		
UNIT SERIAL # _____		
Unit Installed Minimum clearances per Figure 2 (page 5)?	YES	NO
INSTALLER NAME:		
CITY _____	STATE _____	

ELECTRICAL SYSTEM:		
Electrical connections tight?	YES	NO
Line voltage polarity correct?	YES	NO
Rated Voltage: _____ VOLTS		
L1-L2 Volts: _____ VOLTS		
Has the thermostat been calibrated?	YES	NO
Is the thermostat level?	YES	NO
Is the heat anticipator setting correct?(If Applicable)	YES	NO

REFRIGERATION SYSTEM:		
Was unit given 24 hr warm up period for crankcase heaters (if applicable)?	YES	NO
Stage-1 Liquid Pressure (high side) _____		
Stage-1 Suction Pressure (low side) _____		
Has the owner's information been reviewed with the customer?	YES	NO
Has the Literature Package been left with the unit?	YES	NO

INSTALLER: PLEASE LEAVE THESE INSTRUCTIONS WITH THE OWNER.

