

## INSTALLATION INSTRUCTIONS

### Single Package Gas Heating / Electric Cooling



Premium Model Shown

#### **⚠ WARNING:**

##### FIRE OR EXPLOSION HAZARD

- Failure to follow safety warnings exactly could result in serious injury or property damage.
- Installation and service must be performed by a qualified installer, service agency or the gas supplier.
- Do not store or use gasoline or other flammable vapors and liquids in the vicinity of this or any other appliance.

##### WHAT TO DO IF YOU SMELL GAS

- Do not try to light any appliance.
- Do not touch any electrical switch; do not use any phone in your building.
- Leave the building immediately.
- Immediately call your gas supplier from a neighbor's phone. Follow the gas supplier's instructions.
- If you cannot reach your gas supplier, call the fire department.

#### **⚠ AVERTISSEMENT**

##### RISQUE D'INCENDIE OU D'EXPLOSION

- Le non-respect des avertissements de sécurité pourrait entraîner des blessures graves, la mort ou des dommages matériels.
- L'installation et l'entretien doivent être effectués par un installateur qualifié, un organisme de service ou le fournisseur de gazstaller, service agency or the gas supplier.
- Ne pas entreposer ni utiliser de l'essence ni d'autres vapeurs ou liquides inflammables dans le voisinage de cet appareil, ni de tout autre appareil.

##### QUE FAIRE S'IL Y A UNE ODEUR DE GAZ

- Ne pas tenter d'allumer aucun appareil.
- Ne toucher à aucun interrupteur électrique; n'utiliser aucun téléphone dans le bâtiment.
- Évacuer l'immeuble immédiatement.
- Appeler immédiatement le fournisseur de gaz en employant le téléphone d'un voisin. Respecter à la lettre les instructions du fournisseur de gaz.
- Si personne ne répond, appeler le service des incendies.

## TABLE OF CONTENTS

<b>IMPORTANT SAFETY INFORMATION .....</b>	<b>3</b>	<b>STARTUP &amp; ADJUSTMENTS .....</b>	<b>16</b>
<b>REQUIREMENTS &amp; CODES .....</b>	<b>4</b>	Pre - Start Checklist .....	16
<b>GENERAL INFORMATION .....</b>	<b>5</b>	Start-up Procedure .....	16
Before You Install this Unit .....	5	Air Circulation.....	16
Locating the Equipment.....	5	System Cooling.....	16
Combustion Air Requirements .....	5	System Heating.....	16
Heating Load .....	5	Verifying & Adjusting Temperature Rise.....	16
<b>COMBUSTION AIR &amp; VENTING REQUIREMENTS ...</b>	<b>6</b>	Verifying & Adjusting Firing Rate.....	17
General Information .....	7	Manifold Pressure Adjustment .....	17
Vent Termination .....	7	Verifying Operation of Over-Temperature	
<b>CIRCULATING AIR SUPPLY .....</b>	<b>8</b>	Limit Control .....	17
Air Ducts .....	8	Verifying Burner Operation.....	18
Air Filter Requirements .....	8	Refrigerant Charging.....	18
Unconditioned Spaces.....	8	<b>OPERATING SEQUENCE .....</b>	<b>18</b>
Acoustical Duct Work.....	8	Heating Mode.....	18
<b>UNIT INSTALLATION .....</b>	<b>9</b>	Cooling Mode .....	19
Packaging Removal .....	9	Fan Mode .....	19
Rigging & Hoisting .....	9	<b>REPLACEMENT PARTS.....</b>	<b>19</b>
Clearances to Combustible Materials.....	9	<b>EQUIPMENT MAINTENANCE.....</b>	<b>19</b>
Rooftop .....	9	Cleaning of Heat Exchanger .....	20
Ground Level.....	9	Cleaning of Burners.....	20
Condensate Drain .....	9	<b>COMPONENT FUNCTIONS .....</b>	<b>21</b>
Horizontal to Downflow Conversion.....	9	<b>TROUBLESHOOTING .....</b>	<b>21</b>
<b>ELECTRICAL WIRING.....</b>	<b>10</b>	<b>FIGURES &amp; TABLES .....</b>	<b>22</b>
Pre - Electrical Checklist .....	11	Figure 9. Unit Dimensions.....	22
Grounding.....	11	Table 7. Center of Gravity & Shipping Weights.....	22
Line Voltage.....	11	Airflow Information.....	23
Thermostat / Low Voltage Connections .....	11	Table 8. Nominal Airflow Rates & Temp Rises .....	23
Checking Heat Anticipator Settings.....	11	Gas Information.....	24
Blower Speed .....	12	Table 9. Gas Pipe Capacities .....	24
5-Speed ECM Motor .....	12	Table 10. Gas Flow Rates .....	24
PSC Motor .....	12	Figure 10. Unit Gas Valve Label.....	25
Optional Furnace Control Board Connections .....	12	Electrical Data & Diagrams .....	26
Electronic Air Cleaner .....	12	Table 11. Electrical Data.....	26
Humidifier.....	12	Figure 11. Wiring Diagram (ECM Motor).....	27
<b>GAS SUPPLY &amp; PIPING .....</b>	<b>13</b>	Figure 12. Wiring Diagram (PSC Motor) .....	28
Leak Check.....	13	Charging Tables & Charts .....	29
High Altitude Conversion - Natural Gas .....	14	Table 12. Charging Table for 2 Ton Units .....	29
Lp / Propane Gas Conversion .....	14	Table 13. Charging Table for 2.5 Ton Units .....	29
		Table 14. Charging Table for 3 Ton Units .....	30
		Table 15. Charging Table for 3.5 Ton Units .....	30
		Table 16. Charging Table for 4 Ton Units .....	31
		Figure 13. Charging Chart for 5 Ton Units.....	31
		<b>INSTALLATION/PERFORMANCE CHECKLIST .....</b>	<b>32</b>

## IMPORTANT SAFETY INFORMATION

Please read all instructions before servicing this equipment. Pay attention to all safety warnings and any other special notes highlighted in the manual. Safety markings are used frequently throughout this manual to designate a degree or level of seriousness and should not be ignored. **WARNING** indicates a potentially hazardous situation that if not avoided, could result in personal injury or death. **CAUTION** indicates a potentially hazardous situation that if not avoided, may result in minor or moderate injury or property damage.

---

### **WARNING:**

---

#### **ELECTRICAL SHOCK, FIRE OR EXPLOSION HAZARD**

Failure to follow safety warnings exactly could result in serious injury or property damage.

Improper servicing could result in dangerous operation, serious injury, death or property damage.

- Before servicing, disconnect all electrical power to the unit.
- When servicing controls, label all wires prior to disconnecting. Reconnect wires correctly.
- Verify proper operation after servicing.

---

### **WARNING:**

---

These units are fully charged with R-410A refrigerant and ready for installation. When a system is installed according to these instructions, no refrigerant charging is required. If repairs make it necessary for evacuation and charging, it should only be attempted by qualified, trained personnel thoroughly familiar with this equipment. Some local codes require licensed installation service personnel to service this type of equipment. Under no circumstances should the homeowner attempt to install and/or service this equipment. Failure to comply with this warning could result in equipment damage, personal injury, or death.

---

### **WARNING:**

---

**Do not place combustible material on or against the unit cabinet. Do not place combustible materials, including gasoline and any other flammable vapors and liquids, in the vicinity of the unit.**

---

---

### **WARNING:**

---

**PROPOSITION 65 WARNING: This product contains fiberglass wool, a product known to the state of California to cause cancer. Disturbing the insulation of this product during installation, maintenance, or repair will expose you to fiberglass wool.**

- **Breathing this material may cause respiratory irritations or may cause lung cancer.**
- **Fiberglass wool may also cause eye irritation, skin sensitization, or other allergic responses in susceptible individuals.**
- **Always wear goggles, disposable gloves, long sleeved shirt, and appropriate breathing protection when working near this insulation. If contact with skin occurs, wash immediately with soap and water. In case of contact with eyes, flush immediately with water for at least 15 minutes. Contact a physician if needed.**

---

### **WARNING:**

---

The information listed below and on the next page must be followed during the installation, service, and operation of this unit. Unqualified individuals should not attempt to interpret these instructions or install this equipment. Failure to follow safety recommendations could result in possible damage to the equipment, serious personal injury or death.

- Before beginning the installation, verify that the unit model is correct for the job. The unit model number is printed on the data label. Follow all precautions in the literature, on tags, and on labels provided with the equipment. Read and thoroughly understand the instructions provided with the equipment prior to performing the installation and operational checkout of the equipment.
- Never test for gas leaks with an open flame. Use a commercially available soap solution to check all connections. See page 13.
- Installation of equipment may require brazing operations. Installer must comply with safety codes and wear appropriate safety equipment (safety glasses, work gloves, fire extinguisher, etc.) when performing brazing operations.
- This equipment is **NOT** to be used for temporary heating of buildings or structures under construction.
- Use caution when handling this appliance or removing components. Personal injury can occur from sharp metal edges present in all sheet metal constructed equipment.
- Follow all precautions in the literature, on tags, and on labels provided with the equipment. Read and

thoroughly understand the instructions provided with the equipment prior to performing the installation and operational checkout of the equipment.

- The installer should become familiar with the units wiring diagram before making any electrical connections to the unit. See the unit wiring label or Figures 11 & 12 (pages 27 & 28).

## REQUIREMENTS & CODES

- **This equipment must be installed in accordance with instructions outlined in this manual, all applicable local building codes, and the current revision of the National Fuel Gas Code (NFPA54/ANSI Z223.1) or the Natural Gas and Propane Installation Code, CAN/CGA B149.1.**
- All electrical wiring must be completed in accordance with local, state and national codes and regulations and with the National Electric Code (ANSI/NFPA 70) or in Canada the Canadian Electric Code Part 1 CSA C.22.1.
- The installer must comply with all local codes and regulations which govern the installation of this type of equipment. Local codes and regulations take precedence over any recommendations contained in these instructions. Consult local building codes and the National Electrical Code (ANSI C1) for special installation requirements.
- This equipment contains liquid and gaseous refrigerant under high pressure. Installation or servicing should only be performed by qualified trained personnel thoroughly familiar with this type equipment.
- Install this unit only in a location and position as specified on page 5. This unit is designed only for outdoor installations and should be located with consideration of minimizing the length of the supply and return ducts. Consideration should also be given to the accessibility of fuel, electric power, service access, noise, and shade.
- Air Ducts must be installed in accordance with the standards of the National Fire Protection Association “Standards for Installation of Air Conditioning and Ventilation Systems” (NFPA 90A), “Standard for Installation of Residence Type Warm Air Heating and Air Conditioning Systems” (NFPA 90B), these instructions, and all applicable local codes.
- Consult Table 10 (page 23), and the rating plate for the proper circulating air flow and temperature rise. It is important that the duct system be designed to provide the correct flow rates and external pressure rise. An improperly designed duct system can result in nuisance shutdowns, and comfort or noise issues.

- Use only with the type of gas approved for this unit. Refer to the unit rating plate.
- Provide adequate combustion and ventilation air to the unit. See pages 6 - 7.
- Provide adequate clearances around the combustion air intake louvers. See Figure 1 (page 5).
- Combustion products must be discharged outdoors. Connect this unit to an approved vent system only, as specified on page 7.
- The information listed below is for reference purposes only and does not necessarily have jurisdiction over local or state codes. Always consult with local authorities before installing any gas appliance.

### Combustion & Ventilation Air

- US: National Fuel Gas Code (NFGC), Air for Combustion and Ventilation
- CANADA: Natural Gas and Propane Installation Codes (NSCNGPIC), Venting Systems and Air Supply for Appliances

### Duct Systems

- US and CANADA: Air Conditioning Contractors Association (ACCA) Manual D, Sheet Metal and Air Conditioning Contractors National Association (SMACNA), or American Society of Heating, Refrigeration, and Air Conditioning Engineers (ASHRAE) Fundamentals Handbook

### Electrical Connections

- US: National Electrical Code (NEC) ANSI/NFPA 70
- CANADA: Canadian Electrical Code CSA C22.1

### Gas Piping & Gas Pipe Pressure Testing

- US: NFGC and National Plumbing Codes
- CANADA: NSCNGPIC

### General Installation

- US: Current edition of the NFGC and the NFPA 90B. For copies, contact the National Fire Protection Association Inc., Batterymarch Park, Quincy, MA 02269; or American Gas Association, 400 N. Capitol, N.W., Washington DC 20001 or [www.NFPA.org](http://www.NFPA.org)
- CANADA: NSCNGPIC. For a copy, contact Standard Sales, CSA International, 178 Rexdale Boulevard, Etobicoke (Toronto), Ontario, M9W 1R3 Canada

### Safety

- US: (NFGC) NFPA 54–1999/ANSI Z223.1 and the Installation Standards, Warm Air Heating and Air Conditioning Systems ANSI/NFPA 90B.
- CANADA: CAN/CGA-B149.1 and .2–M00 National Standard of Canada. (NSCNGPIC)

## GENERAL INFORMATION

This Single Package Gas Heating / Electric Cooling Unit is designed only for outdoor rooftop or ground level slab installations and can be readily connected to the high static duct system of a home. This unit has been tested for capacity and efficiency in accordance with AHRI standards and will provide many years of safe and dependable comfort, providing it is properly installed and maintained. With regular maintenance, this unit will operate satisfactorily year after year. Abuse, improper use, and/or improper maintenance can shorten the life of the appliance and create unsafe hazards.

To achieve optimum performance and minimize equipment failure, it is recommended that periodic maintenance be performed on this unit. The ability to properly perform maintenance on this equipment requires certain tools and mechanical skills.

### Before you install this unit

- ✓ The cooling load of the area to be conditioned must be calculated and a system of the proper capacity selected. It is recommended that the area to be conditioned be completely insulated and vapor sealed.
- ✓ Check the electrical supply and verify the power supply is adequate for unit operation. Consideration should be given to availability of electric power, service access, noise, and shade. If there is any question concerning the power supply, contact the local power company.
- ✓ All units are securely packed at the time of shipment and upon arrival should be carefully inspected for damage prior to installing the equipment at the job site. Verify coil fins are straight. If necessary, comb fins to remove flattened or bent fins. Claims for damage (apparent or concealed) should be filed immediately with the carrier.
- ✓ Survey the job site to determine the best location for setting the unit. Choose an appropriate location that minimizes the length of the supply and return air ducts.
- ✓ Please consult your dealer for maintenance information and availability of maintenance contracts. Please read all instructions before installing the unit.

## Locating the Equipment

- Select a solid, level position, preferably on a concrete slab, slightly above the grade level, and parallel to the home. **DO NOT PLACE UNIT UNDER THE HOME.**
- Overhead obstructions, poorly ventilated areas, and areas subject to accumulation of debris should be avoided. Do not place the unit in a confined space or recessed area where discharge air from the unit to re-circulate into the condenser air inlet, through the coil.
- Sufficient clearance for unobstructed airflow through the louvered control access panel and outdoor coil must be maintained in order to achieve rated performance. See Figure 1 for minimum clearances to obstructions.
- A clearance of at least 36 inches from the blower access panel and from the louvered control access panel is recommended for servicing and maintenance. **Where accessibility to combustibles clearances are greater than minimum clearances, accessibility clearances must take preference.**
- The hot condenser air must be discharged up and away from the home, and if possible, in a direction with the prevailing wind.
- If practical, place the air conditioner and its ducts in an area where they will be shaded from the afternoon sun, when the heat load is greatest.

## Heating Load

This unit should be sized to provide the design heating load requirement. Heating load estimates can be made using approved methods available from Air Conditioning Contractors of America (Manual J); American Society of Heating, Refrigerating, and Air Conditioning Engineers; or other approved engineering methods. For installations above 2,000 ft., the unit should have a sea level input rating large enough that it will meet the heating load after deration for altitude.

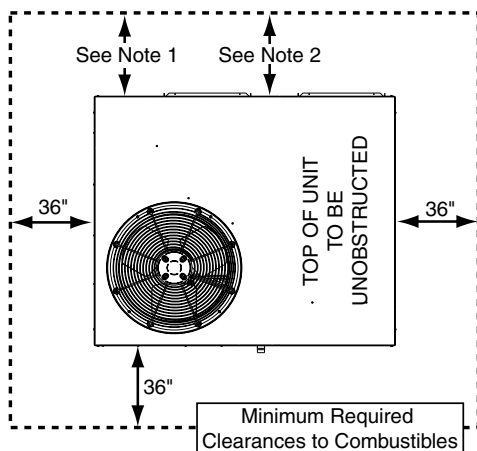

**NOTE 1:** 6" When coil is present on duct side.

**NOTE 2:** 1" When no coil is present on duct side.

**Figure 1. Clearance Requirements**

## COMBUSTION AIR & VENTING REQUIREMENTS

### **WARNING:**

#### **CARBON MONOXIDE POISONING HAZARD**

Failure to follow the steps outlined below for each appliance connected to the venting system being placed into operation could result in carbon monoxide poisoning or death. The following steps shall be followed with each individual appliance connected to the venting system being placed in operation, while all other appliances connected to the venting system are not in operation:

1. Seal any unused openings in the venting system.
2. Inspect the venting system for proper size and horizontal pitch, as required in the National Fuel Gas Code, ANSI Z223.1/NFPA 54 or the CSA B149.1, Natural Gas and Propane Installation Codes and these instructions. Determine that there is no blockage or restriction, leakage, corrosion and other deficiencies which could cause an unsafe condition.
3. As far as practical, close all building doors and windows and all doors between the space in which the appliance(s) connected to the venting system are located and other spaces of the building.
4. Close fireplace dampers.
5. Turn on clothes dryers and any appliance not connected to the venting system. Turn on any exhaust fans, such as range hoods and bathroom exhausts, so they are operating at maximum speed. Do not operate a summer exhaust fan.
6. Follow the lighting instructions. Place the appliance being inspected into operation. Adjust the thermostat so appliance is operating continuously.
7. Test for spillage from draft hood equipped appliances at the draft hood relief opening after 5 minutes of main burner operation. Use the flame of a match or candle.
8. If improper venting is observed during any of the above tests, the venting system must be corrected in accordance with the National Fuel Gas Code, ANSI Z223.1/NFPA 54 and/or CSA B149.1, Natural Gas and Propane Installation Codes.
9. After it has been determined that each appliance connected to the venting system properly vents when tested as outlined above, return doors, windows, exhaust fans, fireplace dampers and any other gas-fired burning appliance to their previous conditions of use.

### **AVERTISSEMENT:**

#### **RISQUE D'EMPOISONNEMENT AU MONOXYDE DE CARBONE**

Le non-respect des consignes suivantes portant sur chacun des appareils raccordés au système d'évacuation mis en service pourrait entraîner l'empoisonnement au monoxyde de carbone ou la mort. Les consignes suivantes doivent être observées pour chaque appareil raccordé au système d'évacuation mis en service si les autres appareils raccordés au système ne sont pas en service:

1. Sceller toute ouverture non utilisée de la système d'évacuation;
2. S'assurer que la système d'évacuation présente des dimensions et une pente horizontale conformes à la norme ANSI Z223.1/NFPA 54, intitulée National Fuel Gas Code ou aux codes d'installation CSA-B149.1, ainsi qu'aux présentes instructions. S'assurer que la système d'évacuation n'est pas bloquée, restreinte, corrodée, qu'elle ne fuit pas et qu'elle ne présente aucun autre défaut potentiellement dangereux;
3. Dans la mesure du possible, fermer toutes les portes et fenêtres du bâtiment, et toutes les portes entre la pièce où se trouve l'appareil raccordé à la système d'évacuation et les autres pièces du bâtiment.
4. Fermer les registres des foyers;
5. Mettre en service les sècheuses et tout autre appareil qui n'est pas raccordé à la système d'évacuation. Faire fonctionner à régime maximal tout ventilateur d'évacuation, tel que les hottes de cuisinière et les ventilateurs de salles de bains. Ne pas mettre en service les ventilateurs d'été.
6. Respecter les instructions d'allumage. Mettre en service l'appareil à l'essai. Régler le thermostat de manière à ce que l'appareil fonctionne sans interruption;
7. Vérifier s'il y a débordement à l'orifice d'évacuation du coupe tirage des appareils dotés d'un coupe tirage 5 minutes après l'allumage du brûleur principal. Utiliser la flamme d'une allumette ou d'une chandelle.
8. Si l'on constate, au cours de l'un des essais qui précèdent, que l'évacuation est déficiente, corriger le système d'évacuation conformément à la norm ANSI Z223.1/NFPA 54, National Fuel Gas Code, et (ou) aux codes d'installation CSA B149.1.
9. Après avoir déterminé que tous les appareils raccordés à la système d'évacuation évacuent correctement tel que prescrit ci-dessus, rouvrir les portes et les fenêtres et remettre les ventilateurs d'évacuation, les registres de foyers et tout autre appareil fonctionnant au gaz à leur état de fonctionnement initial.

## General Information

### **WARNING:**

**Installation methods other than those described in the following sections must comply with the National Fuel Gas Code and all applicable local codes for providing sufficient combustion air to the unit.**

- Provisions must be made during the installation of this unit that provide an adequate supply of air for combustion.
- Instructions for determining the adequacy of an installation can be found in the current revision of the NFGC (ANSI Z223.1 / NFPA54). **Consult local codes for special requirements.** These requirements are for US installations as found in the NFGC.
- The requirements in Canada (B149.1) are structured differently. Consult with B149.1 and local code officials for Canadian installations.

### **WARNING:**

**Combustible air must not be drawn from a contaminated atmosphere. Excessive exposure to contaminated combustion air will result in safety and performance related problems.**

- To maximize heat exchanger life, the combustion air must be free of chemicals that can form corrosive acidic compounds in the combustion gases. The recommended source of combustion air is to use clean air from outside. **DO NOT place any chemicals with flammable or caustic vapors or these other corrosive chemicals near the vent termination:**
  - Gasoline/Kerosene
  - Permanent wave solutions
  - Chlorinated waxes and cleaners
  - Chlorine based swimming pool chemicals
  - Water softening chemicals
  - De-icing salts or chemicals
  - Carbon tetrachloride
  - Halogen type refrigerants
  - Cleaning solvents
  - Cements, glues, paint removers, varnishes, etc.
  - Hydrochloric acid
  - Masonry acid washing materials
  - Plumbing Stack

### **Vent Termination**

This unit has been equipped with an integral venting system and designed to operate only with this venting system. No additional venting shall be used. This unit must be vented to the outdoors.

### **WARNING:**

**This unit is intended for outdoor installation only. Do not vent the unit through a conventional venting system.**

A vent cover assembly has been supplied with the unit and can be found secured to the gas controls within the control area of this unit. **The vent cover assembly must be installed to assure proper operation of the unit.** Figure 2 shows the proper installation of the vent cover assembly over the vent outlet on the exterior of the corner panel. The fasteners used to secure the vent cover assembly have been included in the owner's package. The following list summarizes the requirements for the location of the vent system termination:

- The location of the vent termination must be consistent with the National Fuel Gas Code (ANSI Z223.1) or CAN/CGA-B149 Installation Codes.
- The vent termination must be located at least 4 feet horizontally from any electric meters, gas meters, regulators, and relief equipment.
- The vent termination must be located at least 3 feet above any forced air inlet located within 10 feet.
- The vent termination must be located at least 4 feet below, 4 feet horizontally from, or 1 foot above any door, window, or gravity air inlet into any building.
- The vent termination must be located at least 1 foot above grade.
- The unit should be installed in a way that prevents any obstruction of the vent termination during accumulating snow.
- The unit installation shall avoid areas where condensate drainage may cause problems by dropping on planters or patios, etc. Also verify exhaust gases will not impinge on windows or building surfaces, which may be compromised or damaged by condensation.
- Do not install the unit such that exhaust from the vent termination is directed into window wells, stairwells, under decks, or in alcoves or similarly recessed areas. The vent termination must not be located above any public walkways.

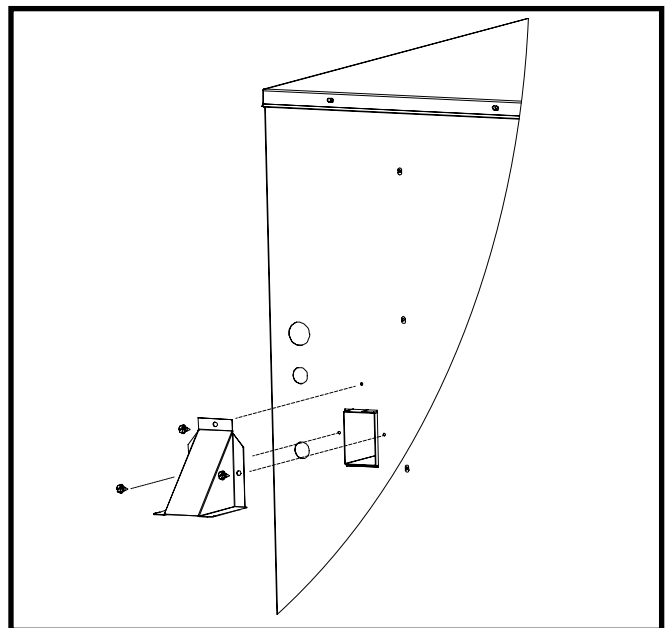

**Figure 2. Vent Assembly**

## CIRCULATING AIR SUPPLY

### **WARNING:**

Products of combustion must not be allowed to enter the return air ductwork or the circulating air supply. Failure to prevent products of combustion from being circulated into the living space can create potentially hazardous conditions including carbon monoxide poisoning that could result in personal injury or death.

All return ductwork must be adequately sealed, all joints must be taped, and the ductwork must be secured to the unit with sheet metal screws. When return air is provided through the bottom of the unit, the joint between the unit and the return air plenum must be air tight.

The roof curb or cement pad on which the unit is mounted must provide sound physical support of the unit with no gaps, cracks, or sagging between the unit and the curb or pad.

Return air and circulating air ductwork must not be connected to any other heat producing device such as a fireplace insert, stove, etc. Doing so may result in fire, explosion, carbon monoxide poisoning, personal injury, or property damage.

### Air Ducts

This unit is designed only for use with a supply and return duct. Air ducts should be installed in accordance with the standards of the National Fire Protection Association "Standard for Installation of Air Conditioning Systems" (NFPA 90A), "Standard for Installation of Residence Type Warm Air Heating and Air Conditioning Systems" (NFPA 90B), and all applicable local codes. NFPA publications are available by writing to: National Fire Protection Association, Batterymarch Park, Quincy, ME 02269 or visit [www.NFPA.org](http://www.NFPA.org) on the web.

- Design the duct work according to Manual D by the Air Conditioning Contractors of America (ACCA).
- The ducts must be properly sized not to exceed 0.30 inches WC pressure drop per 100 feet of equivalent duct at 400 SCFM per nominal ton of cooling capacity.
- Duct work should be attached directly to the unit flanges for horizontal applications.
- If roof curb is installed, the ducts must be attached to the curb duct supports, not the unit.
- It is recommended that the outlet duct be provided with a removable access panel. The opening should be accessible when the unit is installed in service and shall be sized so that smoke or reflected light may be observed inside the casing to indicate the presence of leaks in the heat exchanger. The cover for the opening shall be attached in a way that will prevent leaks.
- If outside air is utilized as return air to the unit for ventilation or to improve indoor air quality, the system

must be designed so that the return air to the unit is not less than 50° F (10° C) during heating operation.

### Air Filter Requirements

### **WARNING:**

Never operate the unit without a filter in place. Dust and lint could accumulate on internal parts, resulting in loss of efficiency, equipment damage and possible fire.

**NOTE TO INSTALLER:** After installing or replacing the filtration system for this unit, add the following statement on or adjacent to the filter service panel: "**Replace filter(s) installed in your system only with the same dimensional size filters that are being replaced.**"

- A suitable air filter must be installed upstream of the evaporator coil of the return air system. Refer to Table 1 for recommended external filter sizes.
- All return air must pass through the filters before entering the evaporator coil. It is important that all filters be kept clean and replaced frequently to ensure proper operation of unit. Dirty or clogged filters will reduce the efficiency of the unit and result in unit shutdowns.
- Air filter pressure drop must not exceed 0.08 inches WC.

Nominal Cooling (Tonnage)	Approximate Air Flow Range (CFM)	Approximate Filter Area (Sq. In.)*	Recommended Filter Size (In. x In.)
2.0	600-900	450	20 x 25
2.5	750-1200	550	20 x 30
3.0	1100-1300	625	25 x 25
3.5	1200-1600	750	24 x 30
4.0	1400-1800	850	18 x 24 (2 required)
5.0	1700-2200	1000	20 x 25 (2 required)

\* Based on velocity of 300 ft/min for disposable filters.

**Table 1. Recommended External Air Filter Sizes**

### Unconditioned Spaces

All duct work passing through unconditioned space must be properly insulated to minimize duct losses and prevent condensation. Use insulation with an outer vapor barrier. Refer to local codes for insulation material requirements.

### Acoustical Duct Work

Certain installations may require the use of acoustical lining inside the supply duct work.

- Acoustical insulation must be in accordance with the current revision of the Sheet Metal and Air Conditioning Contractors National Association (SMACNA) application standard for duct liners.
- Duct lining must be UL classified batts or blankets with a fire hazard classification of FHC-25/50 or less.
- Fiber duct work may be used in place of internal duct liners if the fiber duct work is in accordance with the current revision of the SMACNA construction standard on fibrous glass ducts. Fibrous duct work and internal acoustical lining must be NFPA Class 1 air ducts when tested per UL Standard 181 for Class 1 ducts.

## UNIT INSTALLATION

### Packaging Removal

Remove the shipping carton and User's Manual from the equipment. For rooftop installations, remove and discard the two supports attached beneath the unit.

### Rigging & Hoisting

---

#### **WARNING:**

---

**To avoid the risk of property damage, personal injury, or death, it is the rigger's responsibility to ensure that whatever means are used to hoist the unit are safe and adequate:**

- **The lifting equipment must be adequate for the load. Refer to Table 7 (page 22) for unit weights.**
  - **The unit must be lifted from the holes in the base rails using cables or chains.**
  - **Spreader bars are required to protect the unit and ensure even loading.**
  - **Keep the unit in an upright position at all times. The rigging must be located outside the units center of gravity. Refer to Figure 9 (page 22) for locating the center of gravity.**
  - **All panels must be securely in place during rigging and hoisting.**
- 

### Clearances to Combustible Materials

These units are certified as combination heating and cooling equipment for outdoor rooftop or ground level installations. Units may be installed on combustible flooring or Class A, B, or C roofing material when used with bottom supply and return air ducts as long as the following requirements are met:

- If using bottom discharge with return air ducts a roof curb must be installed prior to unit installation. See Rigging and Hoisting section for setting of the unit.
- Sufficient clearance for unobstructed airflow through the outdoor coil must also be maintained in order to achieve rated performance. See page 5 for information about locating the equipment.

### Rooftop

Rooftop installations must be located according to local building codes or ordinances and these requirements:

- The roof must be capable of handling the weight of the unit. For unit weights, see Table 7. Reinforce the roof if necessary.
- The appropriate accessory roof curb (Figure 3, page 10) must be installed prior to unit installation. The roof curb must be square and level to ensure proper condensate drainage. **Please follow all instructions provided with the kit.**
- Secure roof curb or frame to roof using acceptable mechanical methods per local codes. **NOTE:** Make sure the two supports beneath the unit have been removed.

### Ground Level

Ground level installations must be located according to local building codes or ordinances and these requirements:

- Clearances must be in accordance with those shown in Figure 1 (page 5).
- A suitable mounting pad must be provided and be separate from the building foundation. The pad must be level to ensure proper condensate disposal and strong enough to support the unit's weight. The slab height must be a minimum of 2" (5cm) above grade and with adequate drainage. See Figure 4 (page 10).
- Remove and discard the horizontal Supply and Return duct covers located on the rear of the unit. Form duct attachment flanges by bending the sheet metal outward 90 degrees along the perforated lines.
- Firmly attach ductwork directly to these flanges with screws or other approved mechanical connections and not to the Supply/Return air panels to avoid damage to internal components of the equipment. Once completed use approved duct sealing methods to ensure an air and watertight seal is achieved.

### Horizontal to Downflow Conversion

The unit is shipped ready for horizontal duct connections. If down flow ducts are required, the unit must be converted following the steps below for both the supply and return ducts.

1. Remove the horizontal duct cap.
2. Locate the duct cap inside the duct openings and remove the screw holding it in place.
3. Lift the cap out of the unit. (**Hint:** The cap can be pushed up from the bottom by reaching through the fork slot).
4. Cover the horizontal duct opening with the horizontal duct cap. The insulation will be on the indoor side.
5. Fasten the cover with screws to seal.
6. Remove and discard the two wood supports beneath the unit.

### Condensate Drain

Condensate is removed from the unit through the 3/4" female pipe fitting located on the front side of the unit. See Figure 5 on page 10.

Install a 2 inch condensate trap in the drain line of the same size and prime with water. When connecting rigid drain line, hold the female fitting with a wrench to prevent twisting. **Do not over tighten!** Refer to local codes and restrictions for proper condensate disposal requirements.

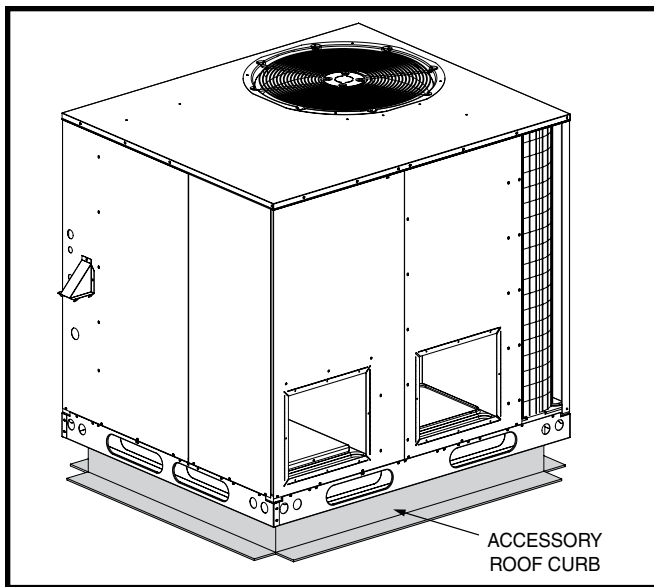

Figure 3. Roof Top Installation

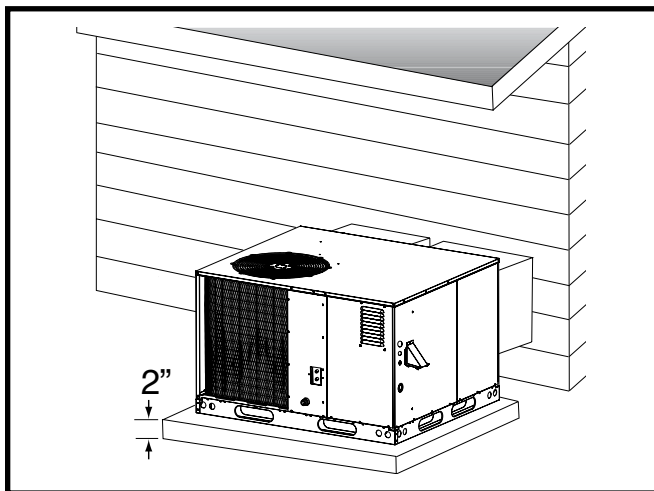

Figure 4. Ground Level Installation

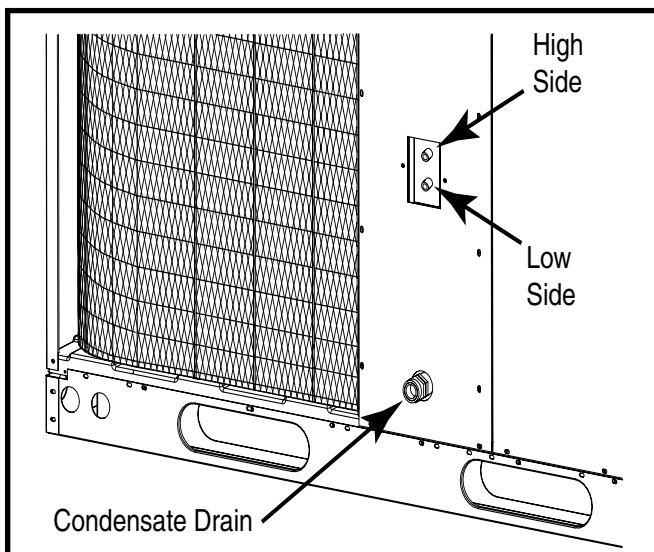

Figure 5. Refrigerant Service Ports & Condensate Drain Locations

## ELECTRICAL WIRING

### ⚠ WARNING:

#### ELECTRICAL SHOCK, FIRE OR EXPLOSION HAZARD

Failure to follow safety warnings exactly could result in serious injury or property damage.

Improper servicing could result in dangerous operation, serious injury, death or property damage.

- Before servicing, disconnect all electrical power to furnace.
- When servicing controls, label all wires prior to disconnecting. Reconnect wires correctly.
- Verify proper operation after servicing.”

### ⚠ AVERTISSEMENT:

#### RISQUE DE CHOC ÉLECTRIQUE, D'INCENDIE OU D'EXPLOSION

Le non-respect des avertissements de sécurité pourrait entraîner un fonctionnement dangereux de l'appareil, des blessures graves, la mort ou des dommages matériels.

Un entretien incorrect pourrait entraîner un fonctionnement dangereux de l'appareil, des blessures graves, la mort ou des dommages matériels

- Couper toute alimentation électrique au générateur d'air chaud avant de prodéder aux travaux d'entretien.
- Au moment de l'entretien des commandes, étiquetez tous les fils avant de les débrancher. S'assurer de les raccorder correctement.
- S'assurer que l'appareil fonctionne adéquatement après l'entretien.

- Electrical connections must be in compliance with all applicable local codes with the current revision of the National Electric Code (ANSI/NFPA 70).
- For Canadian installations the electrical connections and grounding shall comply with the current Canadian Electrical Code (CSA C22.1 and/or local codes).

**IMPORTANT NOTE:** If replacing any of the original wires supplied with the furnace, the replacement wire must be copper wiring having the same gauge, voltage, and temperature rating.

## Pre-Electrical Checklist

- √ Verify the voltage, frequency, and phase of the supply source match the specifications on the unit rating plate.
- √ Verify that the service provided by the utility is sufficient to handle the additional load imposed by this equipment. See Table 2 and Table 11 (page 26) (or the unit rating label) for proper high voltage wiring requirements.
- √ Verify factory wiring is in accordance with the unit wiring diagram (Figures 11 & 12, pages 27 & 28). Make sure the connections didn't loosen during shipping or installation.

## Grounding

### **WARNING:**

**The unit cabinet must have an uninterrupted or unbroken electrical ground to minimize personal injury if an electrical fault should occur. Do not use gas piping as an electrical ground!**

This unit must be electrically grounded in accordance with local codes or, in the absence of local codes, with the National Electrical Code (ANSI/NFPA 70) or the CSA C22.1 Electrical Code. Grounding of the unit is accomplished by using the grounding lug provided in the control box.

## Line Voltage

- The line voltage to the unit should be supplied from a dedicated branch circuit containing the correct fuse or circuit breaker for the unit.
- **An electrical disconnect must be located within sight of and readily accessible to the unit.** This switch shall be capable of electrically de-energizing the outdoor unit. See unit data label for proper incoming field wiring. Any other wiring methods must be acceptable to authority having jurisdiction.
- Use only copper wire for the line voltage power supply to this unit (Table 2). Use proper code agency listed conduit and a conduit connector for connecting the supply wires to the unit. Use of rain tight conduit is recommended.
- Provide power supply for the unit in accordance with the unit wiring diagram and the unit rating plate.
- Overcurrent protection must be provided at the branch circuit distribution panel and sized as shown on the unit rating label and according to applicable local codes. See Table 11 (or the unit rating plate) for minimum circuit ampacity and maximum overcurrent protection limits.
- A wiring diagram is located on the inside cover of the control access panel of the outdoor unit. The installer should become familiar with the wiring diagram before making any electrical connections to the outdoor unit. See Figures 11 & 12.
- Units are shipped from the factory wired for 240 volt transformer operation. For 208V operation, remove the lead from the transformer terminal marked 240V and connect it to the terminal marked 208V.
- Connect the line-voltage leads to the terminals on the contactor inside the control compartment.

## Thermostat / Low Voltage Connections

- This unit is designed to operate from a 24 VAC Class II control circuit. A single stage cooling / single stage heating thermostat should be used with this unit. A 2-stage cooling / 2-stage heating thermostat is recommended for economizer operation. See Figure 6 (page 12) for typical thermostat connection.
- The control circuit wiring must comply with the current provisions of the NEC (ANSI/NFPA 70) and with applicable local codes having jurisdiction. Thermostat connections should be made in accordance with the instructions supplied with the thermostat and the indoor equipment.
- The low voltage wires must be properly connected. Route 24V control wires through the sealing grommet near the power entrance. Recommended wire gauge and wire lengths for typical thermostat connections are listed in Table 3 (page 12).
- Several thermostat options are available depending on the accessories installed with the unit. Select a thermostat that operates in conjunction with the installed accessories.
- The thermostat should be mounted about 5 feet above the floor on an inside wall. **DO NOT** install the thermostat on an outside wall or any other location where its operation may be adversely affected by radiant heat from fireplaces, sunlight, or lighting fixtures, and convective heat from warm air registers or electrical appliances. Refer to the thermostat manufacturer's instruction sheet for detailed mounting information.

## Checking Heat Anticipator Settings

- Add the current draw of the system heating components.  
OR
- Measure the current flow on the thermostat **R-W** circuit after the circulating blower motor has started. Set the heat anticipator according to the thermostat manufacturer's instructions for heat anticipator settings.

COPPER WIRE SIZE — AWG (1% Voltage Drop)				
Supply Wire Length-Feet				Supply Circuit Ampacity
200	150	100	50	
6	8	10	14	15
4	6	8	12	20
4	6	8	10	25
4	4	6	10	30
3	4	6	8	35
3	4	6	8	40
2	3	4	6	45
2	3	4	6	50
2	3	4	6	55
1	2	3	4	60

Wire Size based on N.E.C. for 60° type copper conductors.

**Table 2. Copper Wire Size**

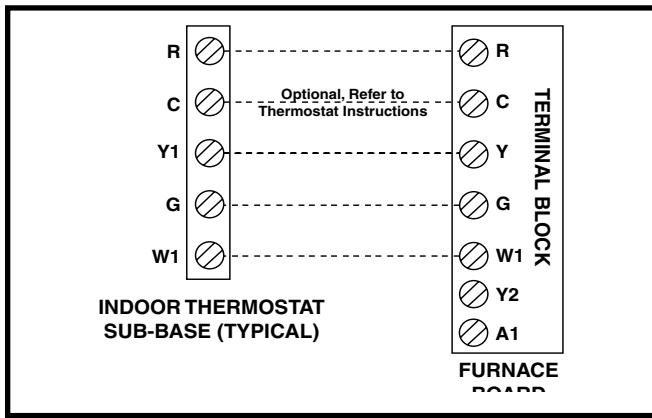

**Figure 6. Typical Thermostat Connection (Field Supplied) for 1-Stage Cool / 1-Stage Heat**

Thermostat Wire Gauge	Recommended T-Stat Wire Length (Unit to T-Stat)	
	2-Wire (Heating)	5-Wire (Heating / Cooling)
24	55	25
22	90	45
20	140	70
18	225	110

**Table 3. Thermostat Wire Gauge**

### Blower Speed

The blower speed is preset at the factory for proper fan only, heating, and cooling operation. These factory settings are listed in Table 8 (page 23). For optimum system performance and comfort, it may be necessary to change the factory set speed.

## ⚠ CAUTION:

**To avoid personal injury or property damage, make sure the motor leads do not come into contact with any uninsulated metal components of the unit.**

### 5-Speed ECM Motor

1. Shut off all electrical power to the unit and remove the blower panel. Locate the orange, red and blue wires terminated to the blower motor. **NOTE:** The orange wire controls cooling operation while the red wire controls heating operation. The blue wire controls fan-only operation.
2. Verify the required speed from the airflow data found in Table 8. Place appropriate wire on the correct motor speed tap for the required airflow point.
3. The integrated furnace control can be set to a 2 or 3 speed mode.

**NOTE 1:** When a **G** only call is received from the thermostat (indicating a continuous fan mode), the blower will run the HEAT speed when the **2-SPD** mode

is selected using the jumper on the control board (factory setting).

**NOTE 2:** When **3-SPD** mode is selected, the FAN speed is energized and may be different than the heating or cooling speed. If no jumper is present, the control defaults to the **2-SPD** HEAT speed mode of operation. A call for heating or cooling takes priority over fan only mode.

### PSC Motor

1. Disconnect all electrical power to the unit and remove the control panel cover.
2. Place the desired blower lead (for cooling) on the furnace board terminal marked COOL.
3. Place the desired blower lead (for heating) on the furnace board marked HEAT. The unused leads can be placed on M1, M2, or M3 on the furnace control board. These are dead terminals.

**NOTE 1:** RED = Low Speed, BLUE = Medium Speed, BLACK = High Speed.

**NOTE 2:** Factory settings require the 024K045 and 030K072 models to have the same cooling and heating speed. These units will have a jumper from heat to cool with the factory setting motor speed tap placed on the jumper.

**NOTE 3:** When a call for the fan (**G**) is made, the furnace board initiates the heat terminal. If heat and cool are jumpered, the fan, heat and cool will have the same blower speed.

## Optional Furnace Control Board Connections

### Electronic Air Cleaner

The furnace control board provides output terminals for an optional electronic air cleaner (EAC) that can be installed in the return air duct of your system. THE EAC output is energized any time the HEAT or COOL blower speed is energized. Control ratings are 1.0 Amp. @ 240 VAC. Output connections are made via board terminals labeled EAC and NEUTRAL.

### Humidifier

The furnace control board provides output terminals for an optional humidifier (HUM) that can be installed on your system. The HUM output is energized any time the furnace inducer motor is energized. Control ratings are 1.0 Amp. @ 240 VAC. Output connections are made via board terminals labeled HUM and NEUTRAL.

Check all factory wiring to the units wiring diagram. Inspect the factory wiring connections to be sure none loosened during shipping or installation.

## GAS SUPPLY & PIPING

### **WARNING:**

#### FIRE OR EXPLOSION HAZARD

- Failure to follow safety warnings exactly could result in serious injury or property damage.
- Installation and service must be performed by a qualified installer, service agency or the gas supplier.
- Do not store or use gasoline or other flammable vapors and liquids in the vicinity of this or any other appliance.

#### WHAT TO DO IF YOU SMELL GAS

- Do not try to light any appliance.
- Do not touch any electrical switch; do not use any phone in your building.
- Leave the building immediately.
- Immediately call your gas supplier from a neighbor's phone. Follow the gas supplier's instructions.
- If you cannot reach your gas supplier, call the fire department.

### **AVERTISSEMENT:**

#### RISQUE D'INCENDIE OU D'EXPLOSION

- Le non-respect des avertissements de sécurité pourrait entraîner des blessures graves, la mort ou des dommages matériels.
- L'installation et l'entretien doivent être effectués par un installateur qualifié, un organisme de service ou le fournisseur de gazstaller, service agency or the gas supplier.
- Ne pas entreposer ni utiliser de l'essence ni d'autres vapeurs ou liquides inflammables dans le voisinage de cet appareil, ni de tout autre appareil.

#### QUE FAIRE S'IL Y A UNE ODEUR DE GAZ

- Ne pas tenter d'allumer aucun appareil.
- Ne toucher à aucun interrupteur électrique; n'utiliser aucun téléphone dans le bâtiment.
- Évacuer l'immeuble immédiatement.
- Appeler immédiatement le fournisseur de gaz en employant le téléphone d'un voisin. Respecter à la lettre les instructions du fournisseur de gaz.
- Si personne ne répond, appeler le service des incendies.

- All gas piping must be installed in compliance with local codes and utility regulations. In the absence of local codes the gas line installation must comply with the latest edition of the National Fuel Gas Code ANSI Z223.1 or CAN/CGA B149 Installation Codes.
- Some local codes require the installation of a manual main shut-off valve and ground joint union external to the unit. The shut-off valve should be readily accessible for service and/or emergency use. Consult the local utility or gas supplier for additional requirements regarding placement of the manual main gas shut-off. See Figure 7 (page 15).
- The manifold pressure must be set to the appropriate value for your installation. Refer to the Manifold Pressure Adjustment section (page 17) for adjustment instructions.
- Gas piping must never run in or through air ducts, chimneys, gas vents, or elevator shafts.
- Compounds used to seal joints on gas piping must be resistant to the actions of LP propane gas.
- The main gas shutoff valve and main power disconnect to the unit must be properly labeled by the installer in case emergency shutdown is required.
- An 1/8 inch NPT plugged tap must be installed in the gas line immediately upstream of the gas supply connection to the unit for use when measuring the gas supply pressure. The plug should be readily accessible for service use.
- A drip leg should be installed in the vertical pipe run to the unit. See Figure 7.

This unit only has right side gas entry. When connecting the gas, provide clearance between the gas supply line and the entry hole in the unit's casing to avoid unwanted noise and/or damage to the unit. A typical gas service hookup is shown in Figure 7.

Table 9 (page 24) lists gas pipe capacities for standard pipe sizes as a function of length in typical applications based on nominal pressure drop in the line.

### **Leak Check**

### **WARNING:**

#### **FIRE OR EXPLOSION HAZARD**

**Never test for gas leaks with an open flame. Check all connections using a commercially available soap solution. A fire or explosion may result causing property damage, personal injury or loss of life. Failure to follow the safety warnings exactly could result in serious injury, death or property damage.**

After the gas piping to the unit is complete, all connections must be tested for gas leaks. This includes pipe connections at the main gas valve, emergency shutoff valve and other gas connectors. A soap and water solution can be applied on each joint or union using a small paintbrush. If any bubbling is observed, the connection is not sealed

adequately and must be retightened. Repeat the tightening and soap check process until bubbling ceases.

- If pressure testing the gas supply lines at pressures greater than 1/2 psig (14 inches WC), the unit must be disconnected from the gas supply piping system to prevent damage to the gas valve.
- If the test pressure is less than or equal to 1/2 psig (14 inches WC), the unit must be isolated from the gas supply line by closing the manual shut-off valve.

### High Altitude Conversion - Natural Gas

Conversion of this unit must be performed by qualified service personnel, using only approved parts. All installations must be made in accordance with the National Fuel Gas Code and/or local jurisdiction codes.

---

## WARNING:

**The reduction of input rating necessary for high altitude installation may only be accomplished with factory supplied orifices. Do not attempt to drill out orifices in the field. Improperly drilled orifices may cause fire, explosion, carbon monoxide poisoning, personal injury or death.**

High altitude conversion can be field performed by a simple adjustment of manifold pressure or a change of the orifices (if necessary) as described on page 17. The changes required depend on the installation altitude and the heating value of the gas (based on sea level) which can be obtained from your local gas utility. The heating value of gas at high altitude is always lower than the sea level heating value. Natural Gas heating values listed in Table 4 (page 15) are based on sea level values.

All factory shipped furnaces are ready to operate using Natural Gas between zero and 4999 ft. above sea level. For altitudes between 5,000 and 10,000 feet above sea level, the unit can be converted by adjusting the unit's manifold pressure. See Table 4 for the correct manifold pressure settings.

**NOTE:** If installing this unit above 2,000 feet, the input rate must be reduced 4% per 1,000 feet of altitude (Example: 12% at 3,000 feet, 16% at 4,000 feet, etc). Deration is necessary to compensate for low atmospheric pressure at high altitudes.

## LP / Propane Gas Conversion

---

## WARNING:

**This unit was equipped at the factory for use with natural gas only. A special kit, supplied by the manufacturer, is required to convert the unit to operate on LP/propane gas. Failure to use the proper conversion kit can cause fire, explosion, property damage, carbon monoxide poisoning, personal injury, or death.**

---

**IMPORTANT NOTE:** When converting a low NOx unit from natural gas to propane (LP) gas, it is necessary to remove the NOx baffles.

Conversion of this equipment to LP/Propane gas must be made by qualified service personnel, using approved factory parts. Conversion to LP can be accomplished by replacing the natural gas orifices with the appropriate LP/Propane orifices and then adjusting the manifold pressure (page 17). Conversion to LP/Propane (sea level and high altitude) is detailed in the installation instructions provided with the conversion kit. **Please follow the instructions provided in each kit.** Approved conversion kits are listed below:

- The United States LP/Propane Gas Sea Level and High Altitude Conversion Kit (P/N [904404A](#)) is for LP/propane conversion in the United States at altitudes between zero and 10,000 ft. above sea level.
- The Canadian LP/Propane Gas Sea Level and High Altitude Conversion Kit (P/N [904405A](#)) is for LP/propane conversions in Canada at altitudes between zero and 4,500 ft. above sea level.

For installations between zero and 4,999 ft. above sea level, a #54 drill size orifice should be used. Installations 5,000 ft. above sea level require a #55 drill size orifice. Table 5 (page 15) lists the correct orifice size to use at different altitudes.

After changing the orifices, it is required that you measure the gas input rate by clocking the gas meter and using the local gas heating value. See Verifying & Adjusting the Firing Rate section on page 17.

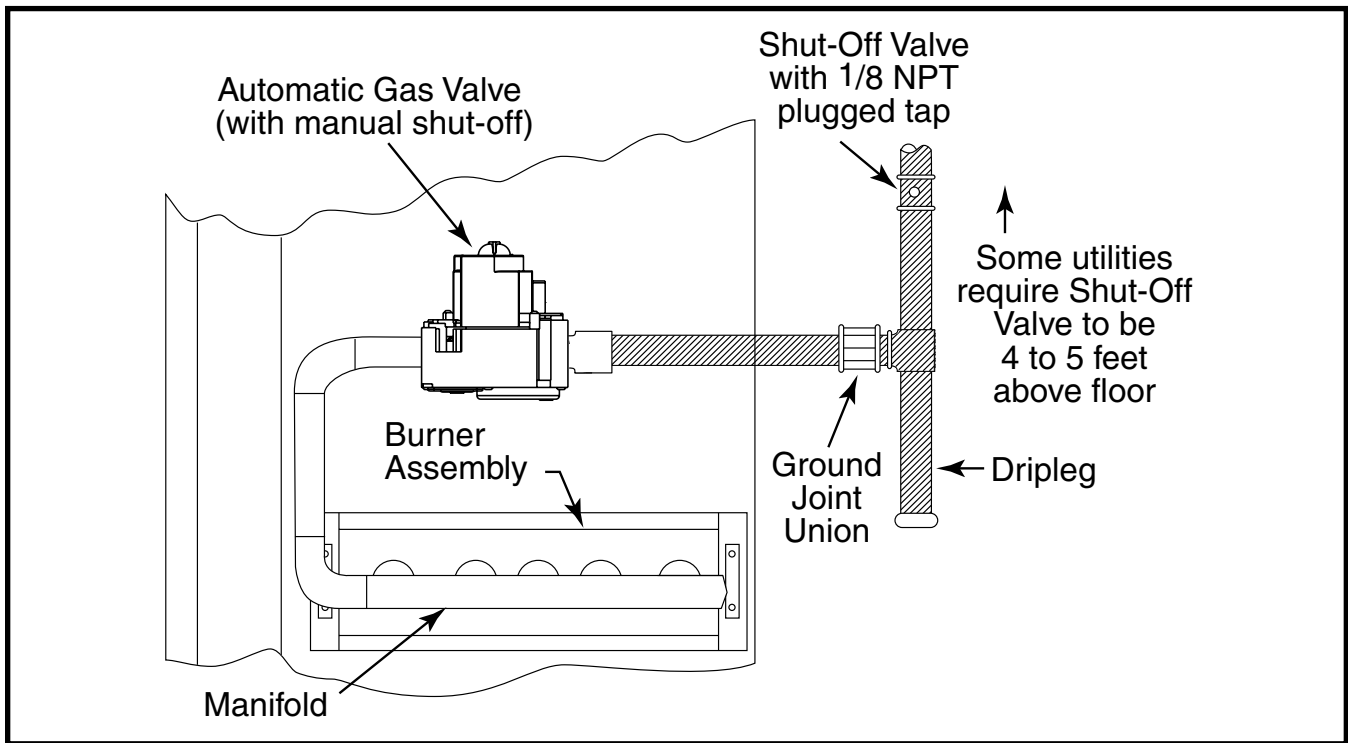

Figure 7. Typical Gas Hookup - Right Side Entry

Natural Gas Heating Value of 800 to 899 Btu/ cu.ft.	ALTITUDE ABOVE SEA LEVEL				
	zero to 1,999	2,000 to 4,999	5,000 to 5,999	6,000 to 7,999	8,000 to 10,000
	3.5	3.5	3.5	3.5	3
Natural Gas Heating Value of 900 to 999 Btu/ cu.ft.	ALTITUDE ABOVE SEA LEVEL				
	zero to 1,999	2,000 to 4,999	5,000 to 5,999	6,000 to 7,999	8,000 to 10,000
	3.5	3.5	3.5	3.2	2.8
Natural Gas Heating Value of 1,000 to 1,100 Btu/ cu.ft.	ALTITUDE ABOVE SEA LEVEL				
	zero to 1,999	2,000 to 4,999	5,000 to 5,999	6,000 to 7,999	8,000 to 10,000
	3.5	3.5	3	2.8	2.5

Table 4. Manifold Pressure Setting (in WC) for Natural Gas

LP Heating Value of 2,500 Btu/ft.3	ALTITUDE ABOVE SEA LEVEL					
	zero to 1,999	2,000 to 2,999	3,000 to 4,999	5,000 to 5,999	6,000 to 7,999	8,000 to 10,000
Manifold Pressure	9.8 - 10	8.8 - 9.0	8.3 - 8.5	9.8 - 10	8.8 - 9.0	8.3 - 8.5
Orifice Size	54	54	54	55	55	55

NOTE: Manifold pressure based on sea level LP heating value of 2,500 Btu/cu. ft.<sup>3</sup>

Table 5. Manifold Pressure Setting (in WC) & Orifice Size for LP Gas

## START UP & ADJUSTMENTS

### Pre-Start Check List

- √ Verify the unit is level and allows condensate to drain.
- √ Verify all clearance requirements are met and there is free airflow to and from the outdoor coil.
- √ Verify that the duct work is sealed to prevent air leakage and air filter is installed.
- √ Verify that the line voltage power leads are securely connected and the unit is properly grounded.
- √ Verify that the low voltage wires are securely connected to the correct terminals in the low voltage area of the control box.
- √ Verify that the gas line service pressure does not exceed 10.0 inches WC (0.36 psig), and is not less than 4.5 inches WC (0.16 psig) for natural gas. For LP gas the line service pressure must not exceed 14 inches WC (0.51 psig) and must not be less than 11.0 inches WC (0.40 psig).
- √ Verify that the flame roll-out control is closed. If necessary, press the red button to reset the control. **DO NOT** install a jumper wire across the control to defeat its function. If the control reopens upon start-up, **DO NOT** reset the control without identifying and correcting the fault condition which caused the control to trip.
- √ Verify that the gas line has been purged and all connections are leak tight.
- √ Verify that all exterior panels are replaced and securely fastened.
- √ Verify that the outdoor fan turns freely.
- √ Verify that the power supply branch circuit overcurrent protection is sized properly.
- √ Verify that the thermostat is wired correctly. The thermostat function switch should be set to OFF and the thermostat fan switch should be set to AUTO.

### Start-Up Procedure

#### **WARNING:**

**If this unit is equipped with crankcase heaters, allow 24 hrs for heating of the refrigerant compressor crankcase prior to start up or anytime the power has been removed for more than 12 hrs. Failure to comply may result in damage or cause premature failure of the system.**

#### Air Circulation

Leave the thermostat system mode on OFF, and set the fan mode to ON. Blower should run continuously. Check the air delivery at the supply registers and adjust register openings for balanced air distribution. Examine ductwork for leaks or obstruction if insufficient air is detected. Set the thermostat fan mode to AUTO. The blower should stop running.

#### System Cooling

1. Set the thermostat's system mode to COOL and the fan mode to AUTO. Gradually lower the thermostat temperature setpoint below room temperature and verify the compressor, fan and indoor blower energize.
2. Feel the air being circulated by the indoor blower and verify that it is cooler than ambient temperature. Listen for any unusual noises. If unusual sounds occur, determine the source of the noise and correct as necessary.
3. Allow the cooling system to operate for several minutes and then set the temperature selector above room temperature. Verify the fan and compressor cycle off with the thermostat. **NOTE:** The blower will also stop after a 40 second delay.

#### System Heating

1. Set the thermostat to the lowest setting.
2. Follow the procedures given on the operating instruction label, this manual or attached inside the louvered control access panel.
3. Set the thermostat above room temperature and verify the Operating Sequence. See page 18.
4. Verify that the compressor and outdoor fan motor are not energized.
5. After the unit has run for approximately five minutes, set the thermostat below room temperature and verify the shutdown sequence; steps 10 -12 in the Operating Sequence section (pages 18-19).

#### **Verifying & Adjusting Temperature Rise**

Verify the temperature rise through the unit is within the range specified on the unit data label. Temperature rises outside the specified range could result in premature heat exchanger failure.

1. Place thermometers in the return and supply air stream as close to the unit as possible. The thermometer on the supply air side must be shielded against direct radiation from the heat exchanger to avoid false readings.
2. Adjust all registers and duct dampers to the desired position. Run the unit for 10 to 15 minutes before taking any temperature readings. The temperature rise is the difference between the supply and return air temperatures.

**NOTE:** For typical duct systems, the temperature rise will fall within the range specified on the data label (with the blower speed at the factory recommended setting) shown in Table 8 (page 23). If the measured temperature rise falls outside the specified range, it may be necessary to change the blower speed. Lowering the blower speed increases the temperature rise and a higher speed decreases the temperature rise.

The unit is equipped with a multi speed motor. On units with ECM type motors, speed selection is made by moving the leads on the blower motor terminal block. If the unit is equipped with a PSC type motor, speed selection is made by moving the leads on the furnace control board. The speed taps for adjusting the motor speed are shown in the unit wiring diagram or Figures 11 & 12 (pages 27 & 28). Refer to the Blower Speed section (page 12) for additional information.

The integrated control starts the circulating air blower 30 seconds after the gas valve is opened. The control is factory wired to turn the blower motor off 90 - 135 seconds after the gas valve is closed.

**ECM Motors:** The heating blower off delay is factory set at 90 seconds. An additional 45 second off delay is programmed into the ECM blower motor for a total of 135 seconds.

**PSC Motors:** A moveable jumper is provided to select between four heat blower off delay times - 60, 90, 120, and 180 seconds. The control is shipped with the jumpers in the 120 second position. The control defaults to 90 seconds if the jumper is not attached.

## Verifying & Adjusting Firing Rate

### **CAUTION:**

**Do not re-drill the burner orifices. If the orifice size must be changed, use only new orifices.**

The firing rate must be verified for each installation to prevent over-firing of the unit. **The firing rate must not exceed the rate shown on the unit data label.** To determine the firing rate, follow the steps below:

1. Obtain the gas heating value (HHV) from the gas supplier.
2. Shut off all other gas fired appliances.
3. Start the unit in heating mode and allow it to run for at least 3 minutes.
4. Measure the time (in seconds) required for the gas meter to complete one revolution.
5. Convert the time per revolution to cubic feet of gas per hour using Table 10 (page 24).
6. Multiply the gas flow rate in cubic feet per hour by the heating value of the gas in Btu per cubic foot to obtain the firing rate in Btu per hour. See Example.

#### **Example:**

- Time for 1 revolution of a gas meter with a 1 cubic foot dial = 40 seconds.
- From Table 10, read 90 cubic feet gas per hour.
- Local heating value of the gas (obtained from gas supplier) = 1,040 Btu per cubic foot.
- Input rate =  $1,040 \times 90 = 93,600$  Btuh.

7. Adjust the manifold pressure if necessary. See Manifold Pressure Adjustment above. For additional information about elevations above 2,000 feet, see page 14.

## Manifold Pressure Adjustment

The manifold pressure must be set to the appropriate value for your installation. To adjust the manifold pressure:

1. Obtain the required manifold pressure setting. Use Table 4 (page 15) for natural gas or Table 5 for LP/propane gas.

**NOTE:** The values listed in the tables are based on sea level values. At higher altitudes, the heating value of gas is lower than the sea level heating value.

2. Remove the regulator capscrew (Figure 8) from the INLET side of the regulator.
3. Slowly turn the adjustment screw inside the regulator to obtain the appropriate manifold pressure.

**NOTE:** Turning the screw clockwise increases the pressure and turning the screw counter-clockwise decreases the pressure. To prevent backing the screw all the way out from the valve, turn the screw slowly.

4. Replace and tighten the regulator capscrew over the adjustment screw.

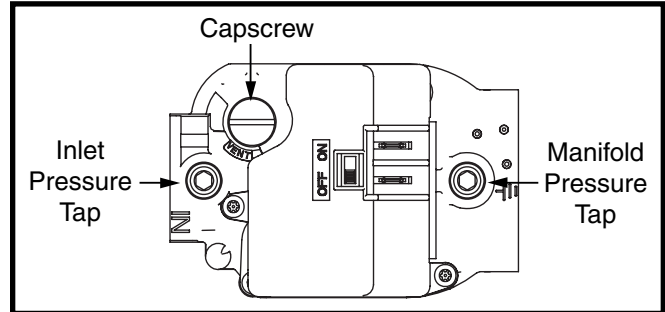

**Figure 8. Regulator Capscrew & Tap Locations**

## Verifying Over-Temperature Limit Control Operation

1. Verify the louvered control access panel is in place and that there is power to the unit.
2. Block the return airflow to the unit by installing a close-off plate in place of or upstream of the filter.
3. Set the thermostat above room temperature and verify the units operating sequence (pages 18 - 19).

**NOTE:** The over-temperature limit control should turn off the gas valve within approximately four minutes (exact time depends on the efficiency of the close-off when blocking the return air). The circulating air and combustion blowers should continue to run when the over-temperature limit control switch opens.

4. Remove the close-off plate immediately after the over-temperature limit control opens. If the unit operates for more than four minutes with no return air, set the thermostat below room temperature, shut off power to the unit, and replace the over-temperature limit control.

## Verifying Burner Operation

### **WARNING:**

**Uninsulated live components are exposed when louvered control access panel is removed.**

1. Remove the louvered control access panel and verify there is power to the unit.
2. Set thermostat above room temperature and observe the ignition sequence. **NOTE:** The burner flame should carry over immediately between all burners without lifting off, curling, or floating. The flames should be blue, without yellow tips. Make sure the flame is drawn into the center of the heat exchanger tube. In a properly adjusted burner assembly, the flame bends down and to the right at the end of the heat exchanger tube. The end of the flame will be out of sight around the bend.
3. After validating flame characteristics, set the thermostat below room temperature and verify the burner flame extinguishes completely.

## Refrigerant Charging

### **WARNING:**

**These units are shipped fully charged with R-410A refrigerant and ready for installation. When a system is installed according to these instructions, no refrigerant charging is required. If repairs make it necessary for evacuation and charging, it should only be done by qualified, trained personnel thoroughly familiar with this equipment. Some local codes require licensed installation/service personnel to service this type of equipment. Under no circumstances should the owner attempt to install and/or service this equipment. Failure to comply with this warning could result in property damage, personal injury, or death.**

### **CAUTION:**

**This unit uses R-410A refrigerant. DO NOT use any other refrigerant in this unit. Use of another refrigerant will damage the unit.**

The system refrigerant charge can be checked and adjusted through the service ports provided at the front panel. Use only gauge lines which have a "Schrader" depression device present to actuate the valve. Draw a vacuum on gauge lines to remove air before attaching them to the service ports on the unit. Refrigerant charging must be done by qualified personnel familiar with safe and environmentally responsible refrigerant handling procedures.

## OPERATING SEQUENCE

The operating sequences for the heating, cooling, and fan modes are described below. Refer to the field and unit wiring diagrams (Figures 11 & 12, pages 27 & 28).

### Heating Mode

1. On a call for heat, the thermostat closes and applies 24 VAC to the **W** terminal of the control board.
2. The control board checks for continuity on the 24 VAC limit control circuit through the over-temperature limit switch and flame rollout switch in series. If an open limit is detected, the control board will energize the inducer blower. All other system functions will be inoperable until the limit circuit closes. While the limit is open, the red LED will pulse at a rate of 1 blink per unit time.
3. The furnace control checks for continuity (24 VAC) across the pressure switch. If the pressure switch is closed, the heat mode sequence will not continue. If it remains closed for 10 seconds, the red LED will flash 3 times repetitively until the fault condition clears.
4. The inducer energizes (if pressure switch is open).
5. The pressure switch will close. If the pressure switch does not close after 10 seconds, the fault LED will flash 2 times and the inducer will continue to run until the switch is closed.
6. The inducer will pre-purge for 30 seconds and then the igniter will start its warm-up as follows:
  - Initial Power up:* After 30 seconds of igniter warm-up, the gas valves (24 VAC) will open. The igniter circuit will stay energized for 3 seconds after the gas valve opens.
  - After Initial Power up:* The control has a programmed adaptive ignition feature which varies the warm-up period as follows: If ignition is successful the warm-up is reduced by 3 seconds on each subsequent call for heat until ignition failure occurs. Upon ignition failure, the warm-up is increased by 3 seconds on the next try. If successful, the timing remains fixed at this level. In general, whenever ignition failure occurs the warm-up interval is increased by 3 seconds on the next try. And if successful, it remains there. Minimum and maximum warm-up time limits are set at 6 and 54 seconds.
7. The furnace control must prove flame via the flame sensor 5 seconds after the gas valves open. If flame is sensed, burners are on and the igniter cools off. If no flame is sensed, the gas valve closes immediately and the inducer continues to run. A second trial for ignition (step 6) begins. If no flame is sensed on the fifth try for ignition, the furnace control is locked and the red LED will blink 4 times repetitively. The thermostat must be opened for at least ten seconds to reset the furnace control after a lock out. Otherwise, the furnace will attempt another ignition sequence in 1 hour.
8. After the gas valve opens (30 seconds), the blower will ramp to the selected airflow and continues to run.
9. When the thermostat has been satisfied, the **W** terminal on the integrated control is de-energized.
10. The gas valve circuit is de-energized and the gas valve closes.

11. The inducer motor will continue to run for the post purge period of 25 seconds.
12. The main blower will continue to run for the BLOWER OFF delay of 90 - 135 seconds.
13. After the BLOWER OFF timer has been satisfied, the integrated control de-energizes the main circulating blower circuit.

### Cooling Mode

1. On a call for cooling, the thermostat closes applying 24 VAC to the **G** & **Y** terminals on the low voltage terminal strip.
2. The **G** terminal applies 24VAC to the **G** terminal of the integrated control, energizing the main circulating blower circuit at the cooling speed.
3. The **Y** terminal applies 24VAC to the contactor.
4. When the thermostat is satisfied, the contactor and integrated control de-energize. Compressor and outdoor fan will stop running.
5. The circulating blower motor de-energizes after a 40 second delay.

### Fan Mode

1. On a call for fan only operation, the thermostat applies 24 VAC to the **G** terminal connected to the **G** terminal of the integrated control.
- 2a. *ECM Motors:* The circulating blower is energized immediately at the heating speed if 2-SPD is selected or fan only speed if 3-SPD is selected on the control.
- 2b. *PSC Motors:* The circulating blower is energized immediately on the heat speed.

**NOTE:** If a call for heat occurs, the circulating blower de-energizes prior to normal heating cycle.

## REPLACEMENT PARTS

Replacement parts are available through all Nordyne distributors. Please have the complete model and serial number of the unit when ordering replacement parts.

#### Electrical:

- |                          |                              |
|--------------------------|------------------------------|
| • Capacitors             | • Pressure Switches          |
| • Compressors            | • Relays                     |
| • Contactors             | • Temperature Limit Switches |
| • Gas Valves             | • Thermostats                |
| • Ignition Controls      | • Time Delay Relays          |
| • Ignitors/Flame Sensors | • Transformers               |

#### Motors:

- Blower Motor
- Fan Motor
- Inducer Blower Motor

#### Components:

- |                    |                  |
|--------------------|------------------|
| • Blower Assembly  | • Fan Grille     |
| • Burner Manifold  | • Filter/Driers  |
| • Burners/Orifices | • Gaskets        |
| • Cabinet Panels   | • Heat Exchanger |
| • Expansion Valves |                  |

## EQUIPMENT MAINTENANCE

### **WARNING:**

#### **ELECTRICAL SHOCK, FIRE OR EXPLOSION HAZARD**

Failure to follow safety warnings exactly could result in serious injury or property damage.

Improper servicing could result in dangerous operation, serious injury, death or property damage.

- Before servicing, disconnect all electrical power to furnace.
- When servicing controls, label all wires prior to disconnecting. Reconnect wires correctly.
- Verify proper operation after servicing.

### **AVERTISSEMENT:**

#### **RISQUE DE CHOC ÉLECTRIQUE, D'INCENDIE OU D'EXPLOSION**

Le non-respect des avertissements de sécurité pourrait entraîner un fonctionnement dangereux de l'appareil, des blessures graves, la mort ou des dommages matériels.

Un entreteint incorrect pourrait entraîner un fonctionnement dangereux de l'appareil, des blessures graves, la mort ou des dommages matériels

- Couper toute alimentation électrique au générateur d'air chaud avant de prodéder aux travaux d'entretein.
- Au moment de l'entretien des commandes, étiquetez tous les fils avant de les débrancher. S'assurer de les raccorder correctement.
- S'assurer que l'appareil fonctionne adéquatement après l'entretien.

### **CAUTION:**

Use care when removing parts from this unit. Personal injury can result from sharp metal edges present in all equipment of sheet metal construction.

Proper maintenance is important to achieve optimum performance from the system. The ability to properly perform maintenance on this equipment requires certain mechanical skills and tools. If you do not possess these skills, contact your dealer for maintenance. Consult your local dealer about the availability of maintenance contracts. Routine maintenance should include the following:

---

**⚠ CAUTION:**

---

**The unit should never be operated without a filter in the return air system. Replace disposable filters with the same type and size.**

---

- Inspect, clean or replace air filters at the beginning of each heating and cooling season, or more frequently if required.
- Inspect the condensate drain and outdoor coil at the beginning of each cooling season. Remove any debris. Clean the outdoor coil and louvers as necessary using a mild detergent and water. Rinse thoroughly with water.
- Inspect the electrical connections for tightness at the beginning of each heating and cooling season.
- The blower compartment should be cleaned monthly during the heating and cooling seasons to remove any dirt and lint that may have accumulated in the compartment or on the blower and motor. Buildup of dirt and lint on the blower and motor can create excessive loads on the motor resulting in higher than normal operating temperatures and possible shortened service life.
- Maintain heat exchanger and burners. The unit should operate for many years without excessive scale buildup in the heat exchanger, however, the heat exchanger, the vent system, and the burners should be inspected and cleaned (if required) by a qualified serviceman annually to ensure continued safe operation. Particular attention must be given to identify deterioration from corrosion or other sources.
- The motors for the circulating air blower, outdoor fan, and combustion blower are pre-lubricated at the factory. No further oiling is required for the life of this product.
- Inspect and clean the screen of the vent cover assembly at the beginning of each heating and cooling season.

### **Cleaning of Heat Exchanger**

---

**⚠ WARNING:**

---

**Holes in the heat exchanger can cause products of combustion to enter the home. Replace the heat exchanger if leaks are found. Failure to prevent products of combustion from being circulated into the living space can create potentially hazardous conditions including carbon monoxide poisoning that could result in personal injury or death.**

---

If the heat exchanger must be cleaned due to soot or scale build up, follow the steps below.

1. Shut off the gas supply to the unit at the meter or at the manual valve in the gas supply piping.
2. Turn off all power to the unit and set the thermostat to the lowest temperature setting.
3. Remove the louvered access panel from the unit.
4. Turn the gas control knob (gas valve) to the OFF position. See Figure 10 (page 25) for gas valve shut off instructions.

5. Disconnect the wires from the gas valve, ignitor, flame sensor, combustion air motor, flame roll-out control, over-temperature limit switch, and pressure switch.
  6. Remove the silicone rubber tube from the collector pan to the pressure switch.
  7. Remove 4 nuts securing the combustion blower to the collector pan. Remove the combustion blower.
  8. Remove all screws securing the collector pan to the unit. Remove the collector pan from the unit.
- 

**⚠ CAUTION:**

---

**To prevent damage to the unit or internal components, it is recommended that two wrenches be used when loosening or tightening nuts. Do not over tighten!**

---

9. Using 2 wrenches, separate the ground-joint union in the gas supply piping at the unit.
10. Remove the piping between the gas valve and the ground-joint union, if necessary.
11. Remove the screws that secure the burner assembly in place and the burner assembly. **BE EXTREMELY CAREFUL NOT TO DAMAGE THE IGNITOR WHILE REMOVING THE BURNER ASSEMBLY.**
12. Attach a round wire brush to a length of high grade stainless steel cable, such as drain clean-out cable. Attach the other end of the spring cable to a variable speed reversible drill. Slowly insert and rotate the cable into the top portion of the heat exchanger. Operate the drill alternating between forward and reverse, working the cable in and out several times to obtain sufficient cleaning. Repeat this process at each exchanger tube.
13. Remove all loosened debris from the heat exchanger tubes using high pressure air and vacuum cleaner.
14. Using a light, check the condition of the upper and lower sections of the heat exchanger tube.
15. Inspect the burners and if necessary, clean them carefully with a soft wire brush and/or the nozzle of a vacuum cleaner. **DO NOT DAMAGE THE IGNITOR OR FLAME SENSOR WHILE CLEANING THE BURNER.**
16. Replace all the parts in reverse order from which they were removed.
17. Follow the operating instructions found on the right side door and the User's Information Manual to return the unit to operation.

### **Cleaning of Burners**

If the burners must be cleaned, follow the steps below.

1. Shut off the gas supply to the unit either at the meter or at a manual valve in the supply piping.
2. Turn off all power to the unit and set the thermostat to the lowest temperature setting.
3. Remove the louvered control access panel from the unit.
4. Turn the gas control knob to the OFF position. See Figure 10 (page 25) for gas valve shut off instructions.
5. Disconnect the wires from the gas valve, ignitor, and flame sensor.

## ⚠ CAUTION:

**To prevent damage to the unit or internal components, it is recommended that two wrenches be used when loosening or tightening nuts. Do not over tighten!**

6. Using two wrenches, separate the ground-joint union in the gas supply piping at the unit.
7. Remove the piping between the gas valve and the ground-joint union (if applicable).
8. Remove all screws securing the burner assembly to the unit.
9. Carefully remove the burner assembly from the unit. **DO NOT DAMAGE THE IGNITER WHILE REMOVING THE BURNER ASSEMBLY.**
10. Inspect the burners for accumulated dust or debris. If necessary carefully clean them with a soft wire brush and a vacuum cleaner. **DO NOT DAMAGE THE IGNITER WHILE CLEANING THE BURNER.**
11. Replace all the parts in reverse order from which they were removed.
12. Follow the lighting instructions found on the lower unit door to return the unit to operation.
13. Verify proper operation after servicing.

### COMPONENT FUNCTIONS

**Flame Roll-Out Control** - The flame roll-out control acts to verify that the burner flame is being drawn into the heat exchanger tubes. If the burner flame is not being drawn into the heat exchanger tubes, the roll-out control will open within several seconds and the integrated control diagnostic light will flash one time. The circulating air blower and combustion blower will continue to operate if the flame roll-out control opens.

**Flame Sensor** - The flame sensor acts to prove that flame has carried over from the ignitor to the right-most burner. If no flame is sensed, the unit will be shut down automatically.

**Gas Valve** - The gas valve controls the flow of gas to the burners. When the gas valve is energized it automatically opens and regulates the gas pressure in the manifold.

**Pressure Switch** - The pressure switch verifies that the inducer motor is drawing the combustion gases through the heat exchanger tubes and venting the gases through the vent system.

**Over-Temperature Limit Control** - The over-temperature limit control prevents the air temperature leaving the unit from exceeding the maximum outlet air temperature. If the limit opens, the integrated control diagnostic will flash one time. The circulating air blower and combustion blower will continue to operate if the over-temperature limit control opens.

## TROUBLESHOOTING

If the unit does not operate in the cooling mode, check the following:

- The thermostat is operating properly
- Electrical power to the unit is turned on
- The filters are not dirty
- The service doors are in place
- The 3 amp fuse is operational
- The anti-short cycle timer's 5 minute cycle has finished.

If the unit does not operate in the heating mode, check the following:

- The thermostat is operating properly
- Electrical power to the unit is turned on
- The filters are not dirty
- The gas is turned on and the manual shut-off valve is open
- The service doors are in place
- The flame roll-out control is closed
- The diagnostic codes listed in Table 6 or on the wiring diagrams (Figures 11 & 12, pages 27 & 28).
- The 3 amp fuse is operational

STATUS LIGHT (Red LED)	FAULT CONDITION
On	Power On
1 Flash	Limit Circuit Open
2 Flashes	Pressure Switch Stuck Open with Inducer ON
3 Flashes	Pressure Switch Stuck Closed with Inducer OFF
4 Flashes	Ignition Failure (Check Ground)
5 Flashes	230 VAC & Neutral Reversed or no ground
Continuous Flash	False Flame or Gas Relay Shorted
Off	Power Off

STATUS LIGHT (Yellow LED)	FAULT CONDITION
Continuous Flash	Low Flame Sensor Signal
On	Flame Present

**Table 6. Diagnostic Codes**

## FIGURES & TABLES

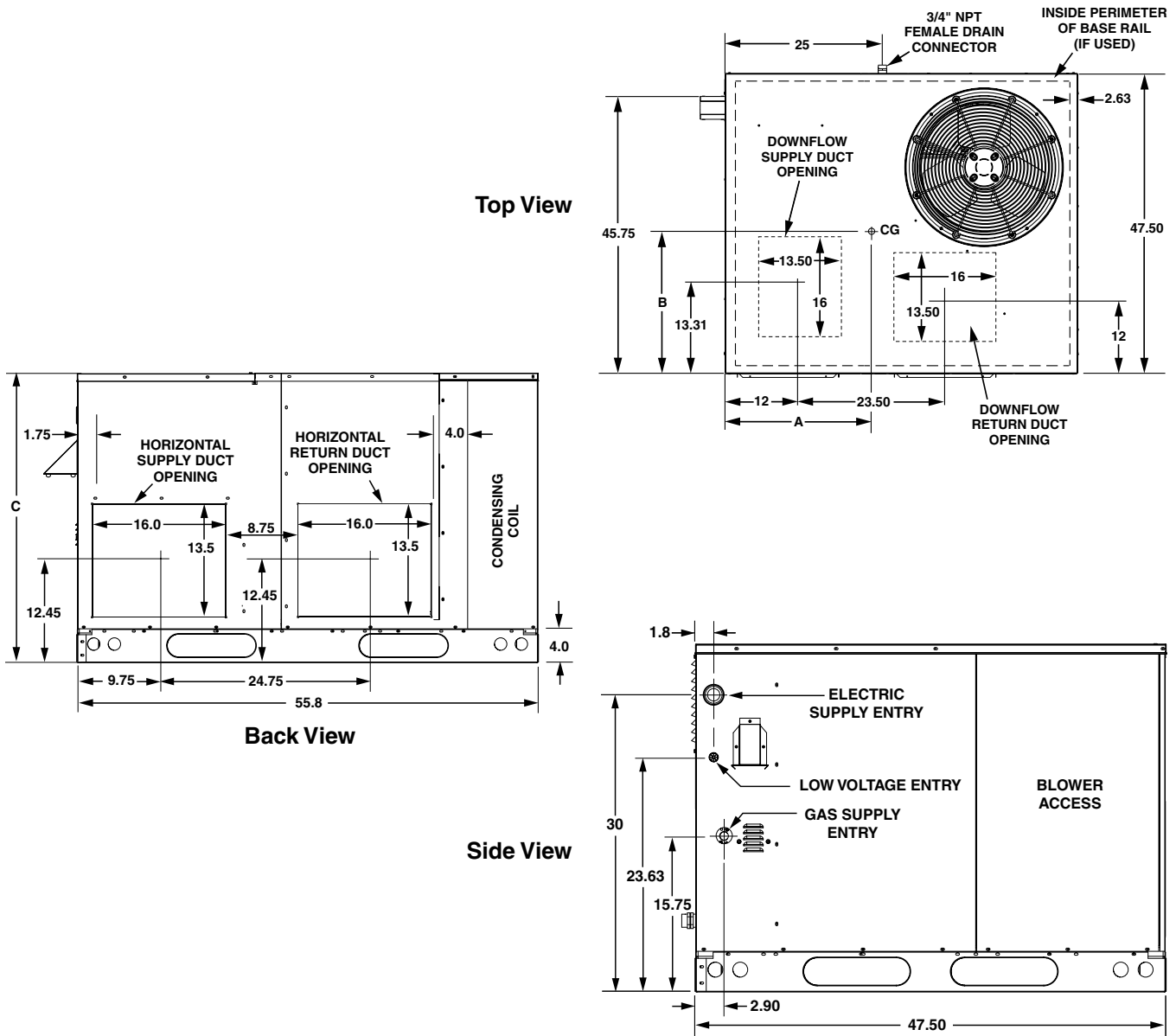

**Figure 9. Unit Dimensions**

Model Number	Unit Weight	Shipping Weight	Center of Gravity		Height in inches (C)	
			A	B	with base rails	without base rails
024K045†	397	413	26.5	26.5	35.0	31.3
024K072†	405	421	26.0	26.5	35.0	31.3
030K045†	398	414	26.5	26.5	35.0	31.3
030K072†	406	422	26.0	26.5	35.0	31.3
036K072†	403	419	26.5	26.5	35.0	31.3
036K096†	411	427	26.5	26.5	35.0	31.3
042K072†	435	453	27.0	26.5	39.0	35.3
042K096†	443	461	27.0	26.5	39.0	35.3
048K096†	453	470	27.5	26.5	39.0	35.3
048K120†	461	478	27.5	26.5	39.0	35.3
X60K096†	472	489	27.5	26.5	43.0	39.3
X60K120†	480	497	27.5	26.5	43.0	39.3

† Denotes "C" or "X"

**Table 7. Center of Gravity & Unit Shipping Weights**

# AIRFLOW INFORMATION

Model Number	Heating Input (Btu/h)	Heating Output (Btu/h)	Heating Rise Range (Btu/h)	Blower Size	Motor HP	Motor Tap	External Static Pressure Drop - inches water column																
							0.1		0.2		0.3		0.4		0.5		0.6		0.7		0.8		
							(cfm)	(°F) Rise	(cfm)	(°F) Rise	(cfm)	(°F) Rise	(cfm)	(°F) Rise	(cfm)	(°F) Rise	(cfm)	(°F) Rise	(cfm)	(°F) Rise	(cfm)	(°F) Rise	
024K045(t)	45,000	36,000	30-60	10 x 10	1/4	LOW ***	1015	34	955	36	880	39	805	43	715	48	635	54	545	63	485	71	
							MED	1255	28	1190	29	1125	31	1055	33	965	40	765	45	680	51	600	51
							HIGH	1460	24	1385	25	1315	26	1240	28	1160	30	1050	33	935	37	830	42
024K072(t)	72,000	57,600	40-70	10 x 10	1/4	MED **	1015	55	955	58	880	63	805	69	715	77	635	87	545	102	485	114	
							MED **	1255	44	1190	46	1125	49	1055	52	965	57	860	64	765	72	680	81
							HIGH	1460	38	1385	40	1315	42	1240	45	1160	48	1050	53	935	59	830	67
030K045(t)	45,000	36,000	30-60	10 x 10	1/4	MED **	1015	34	955	36	880	39	805	43	715	48	635	54	545	63	485	71	
							MED **	1255	28	1190	29	1125	31	1055	33	965	36	860	40	765	45	680	51
							HIGH	1460	24	1385	25	1315	26	1240	28	1160	30	1050	33	935	37	830	42
030K072(t)	72,000	57,600	40-70	10 x 10	1/4	LOW ***	1015	55	955	58	880	63	805	69	715	77	635	87	545	102	485	114	
							MED ***	1255	44	1190	46	1125	49	1055	52	965	57	860	64	765	72	680	81
							HIGH	1460	38	1385	40	1315	42	1240	45	1160	48	1050	53	935	59	830	67
036K072(t)	72,000	57,600	40-70	10 x 10	1/2	Tap T1	1085	51	1025	54	975	57	925	60	850	65	790	70	745	74	695	80	
							Tap T2 **	1249	44	1178	47	1123	49	1065	52	979	57	908	61	858	64	800	69
							Tap T3 **	1390	40	1310	42	1250	44	1185	47	1090	51	1010	55	955	58	890	62
042K072(t)	72,000	57,600	35-65	11 x 10	1/2	Tap T4 *	1495	37	1445	38	1400	40	1355	41	1305	42	1260	44	1210	46	1155	48	
							Tap T5	1560	35	1515	37	1470	38	1420	39	1370	40	1325	42	1280	43	1225	45
							Tap T1	1140	49	1075	51	1110	50	940	59	850	65	770	72	715	77	640	86
042K096(t)	96,000	76,800	45-75	10 x 10	1/2	Tap T2 **	1310	42	1250	44	1180	47	1130	49	1050	53	975	57	895	62	830	67	
							Tap T3 **	1490	37	1440	38	1380	40	1320	42	1255	44	1175	47	1090	51	1020	54
							Tap T4	1621	34	1571	35	1511	37	1466	38	1409	39	1336	41	1255	44	1185	47
048K096(t)	96,000	76,800	40-70	11 x 10	3/4	Tap T5	1665	33	1615	34	1555	36	1515	37	1460	38	1390	40	1310	42	1240	45	
							Tap T1	1270	58	1205	61	1140	65	1050	70	980	75	920	80	830	89	770	96
							Tap T2 **	1490	50	1440	53	1380	53	1320	56	1255	59	1175	63	1090	68	1020	72
060K096(t)	120,000	96,000	45-75	11 x 10	3/4	Tap T3 *	1556	47	1506	49	1446	51	1393	53	1332	55	1256	59	1173	63	1103	67	
							Tap T4	1621	46	1571	47	1511	49	1466	50	1409	52	1336	55	1255	59	1185	62
							Tap T5	1665	44	1615	46	1555	47	1515	49	1460	51	1390	53	1310	56	1240	59
060K120(t)	120,000	96,000	45-75	11 x 10	1	Tap T1	1405	66	1335	69	1270	73	1200	77	1125	82	1065	87	990	93	925	100	
							Tap T2 **	1640	56	1565	59	1500	61	1445	64	1375	67	1310	70	1250	74	1185	78
							Tap T3 *	1775	52	1710	54	1650	56	1600	58	1540	60	1485	62	1425	65	1365	68
060K120(t)	120,000	96,000	45-75	11 x 10	1	Tap T4	1878	49	1821	51	1764	52	1716	54	1654	56	1594	58	1534	60	1479	62	
							Tap T5	2015	46	1970	47	1915	48	1870	49	1805	51	1740	53	1680	55	1630	57
							Tap T1	1240	59	1185	62	1130	65	1085	69	1010	73	940	78	880	84	820	90
060K120(t)	120,000	96,000	45-75	11 x 10	1	Tap T2 **	1635	45	1595	46	1510	49	1485	50	1425	52	1365	54	1305	57	1245	59	
							Tap T3 *	1900	39	1855	40	1795	41	1750	42	1700	43	1650	45	1595	46	1535	48
							Tap T4	2045	36	2010	37	1955	38	1890	39	1835	40	1790	41	1740	42	1695	44
060K120(t)	120,000	96,000	45-75	11 x 10	1	Tap T5	2250	33	2235	33	2180	34	2150	34	2120	35	2080	35	2025	36	2005	37	
							Tap T1	1240	74	1185	78	1130	82	1085	87	1010	91	940	98	880	105	820	112
							Tap T2 **	1635	56	1595	58	1510	61	1485	62	1425	65	1365	68	1305	71	1245	74
060K120(t)	120,000	96,000	45-75	11 x 10	1	Tap T3 *	1900	49	1855	50	1795	51	1750	53	1700	54	1650	56	1595	58	1535	60	
							Tap T4	2045	45	2010	46	1955	47	1890	49	1835	50	1790	52	1740	53	1695	54
							Tap T5	2250	41	2235	41	2180	42	2150	43	2120	44	2080	44	2025	46	2005	46

**Table 8. Nominal Airflow Rates & Temperature Rises (° F)**

\* Denotes factory set cooling speed  
 \*\* Denotes factory set heating speed  
 \*\*\* Denotes factory set cooling and heating speed  
 (t) Part number may contain a C or X.

Heat rise: Btu/h (Input) = CFM \* Δ T \* 1.08  
 Δ T = (Btu/h \* 0.83) / (CFM \* 1.08)

## GAS INFORMATION

GAS PIPE CAPACITIES								
Nominal Pipe Diameter (IN.)	Length of Pipe Run (Feet)							
	10	20	30	40	50	60	70	80
1/2	130	90	75	65	55	50	45	40
3/4	280	190	150	130	115	105	95	90
1	520	350	285	245	215	195	180	170
1 1/4	1,050	730	590	500	440	400	370	350
1 1/2	1,600	1,100	890	760	670	610		

$$\text{Cubic Feet Per Hour Required} = \frac{\text{Input To Furnace (Btu/hr)}}{\text{Heating Value of Gas (Btu/Cu. Ft.)}}$$

**NOTE:** The cubic feet per hour listed in the table above must be greater than the cubic feet per hour of gas flow required by the unit. To determine the cubic feet per hour of gas flow required by the unit, divide the input rate of the unit by the heating value (from gas supplier) of the gas.

**Table 9. Capacity of Black Iron Gas Pipe (cu. ft. per hour)  
for Natural Gas w/ Specific Gravity = 0.60**

GAS FLOW RATES			
TIME FOR ONE REVOLUTION (SECONDS)	CUBIC FEET PER REVOLUTION OF GAS METER		
	1	5	10
10	360	1,800	3,600
12	300	1,500	3,000
14	257	1,286	2,571
16	225	1,125	2,250
18	200	1,000	2,000
20	180	900	1,800
22	164	818	1,636
24	150	750	1,500
26	138	692	1,385
28	129	643	1,286
30	120	600	1,200
32	113	563	1,125
34	106	529	1,059
36	100	500	1,000
38	95	474	947
40	90	450	900
42	86	429	857
44	82	409	818
46	78	391	783
48	75	375	750
50	72	360	720
52	69	346	692
54	67	333	667
56	64	321	643
58	62	310	621
60	60	300	600
62	58	290	581
64	56	281	563

GAS FLOW RATES			
TIME FOR ONE REVOLUTION (SECONDS)	CUBIC FEET PER REVOLUTION OF GAS METER		
	1	5	10
66	55	273	545
68	53	265	529
70	51	257	514
72	50	250	500
74	49	243	486
76	47	237	474
78	46	231	462
80	45	225	450
82	44	220	439
84	43	214	429
86	42	209	419
88	41	205	409
90	40	200	400
92	39	196	391
94	38	191	383
96	38	188	375
98	37	184	367
100	36	180	360
102	35	176	353
104	35	173	346
106	34	170	340
108	33	167	333
110	33	164	327
112	32	161	321
114	32	158	316
116	31	155	310
118	31	153	305
120	30	150	300

**Table 10. Gas Flow Rates (Cubic Feet per Hour)**

## FOR YOUR SAFETY READ BEFORE OPERATING

**WARNING:** If you do not follow these instructions exactly, a fire or explosion may result causing property damage, personal injury, or loss of life.

- A. This appliance does not have a pilot. It is equipped with an ignition device which automatically lights the burner. Do not try to light the burner by hand.
- B. BEFORE OPERATING smell all around the appliance area for gas. Be sure to smell next to the floor because some gas is heavier than air and will settle on the floor.
- WHAT TO DO IF YOU SMELL GAS**
- Do not try to light any appliance.
  - Do not touch any electrical switch; do not use any phone in your building.
  - Immediately call your gas supplier from a neighbor's phone. Follow the gas supplier's instructions.
  - If you cannot reach your gas supplier, call the fire department.
- C. Use only your hand to push in or turn the gas control knob. Never use tools. If the knob will not push in or move by hand, do not try to repair it, call a qualified service technician. Force or attempted repair may result in a fire or explosion.
- D. Do not use this appliance if any part has been under water. Immediately call a qualified service technician to inspect the appliance and to replace any part of the control system and any gas control which has been under water.

## POUR VOTRE SÉCURITÉ. À LIRE AVANT L'EMPLOI

**ATTENTION!** L'inobservation de ces instructions peut entraîner un incendie ou une explosion pouvant causer des dommages à votre propriété à votre personne, ou la mort.

- A. Cet appareil ménager n'a pas de veilleuse. Il est doté d'un système d'allumage automatique. Ne pas essayer d'allumer le brûleur manuellement.
- B. AVANT L'USAGE. Attention à une possible odeur de gaz surtout au niveau du plancher où les gaz les plus lourds ont la tendance de se concentrer.
- EN CAS D'ODEUR DE GAZ.**
- Ne mettre en marche aucun appareil électrique.
  - Ne toucher à aucun commutateur électrique, ne pas employer le téléphone.
  - Quitter le bâtiment immédiatement et avvertir la compagnie du gaz en utilisant le téléphone d'un voisin.
  - A défaut de la compagnie du gaz, avvertir le service des pompiers.
- C. Enfoncer ou faire tourner le robinet à gaz à la main seulement. Ne jamais utiliser d'outils. S'il n'est pas possible de faire tourner ou d'enfoncer le robinet à la main, ne pas essayer de le réparer. Faire appel à un spécialiste. Forcer ou tenter de réparer le robinet pourrait être à l'origine d'une explosion ou d'un incendie.
- D. Il est déconseillé d'utiliser cet appareil en contact prolongé avec l'eau. Faire inspecter ou remplacer toute commande par un technicien qualifié si un des systèmes de contrôle du gaz s'est trouvé sous l'eau.

## OPERATING INSTRUCTIONS

1. **STOP!** Read the safety information above on this label.
2. Set the thermostat to the lowest setting.
3. Turn off all electrical power to the appliance.
4. The appliance's ignition device automatically lights the burner. Do not try to light burner by hand.
5. Remove the control access door/panel (upper door if two-door model).
6. Move the gas control switch to the "OFF" position. (See Figure 1)
7. Wait five (5) minutes to clear out any gas. Then smell for gas, including near the floor. If you smell gas, STOP! Follow "B" in above information. If you don't smell gas, go to the next step.
8. Move the gas control switch to the "ON" position. (See Figure 1)
9. Replace the control access door/panel (upper door if two-door model).
10. Turn on all electrical power to the appliance.
11. Turn the thermostat to a desired setting.
12. If the appliance will not operate, follow the instructions "To Turn Off Gas To Appliance" and call your service technician or gas supplier.

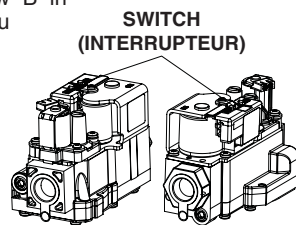

Figure 1

## MODE D'EMPLOI

1. **ATTENTION!** Lire d'abord la liste des mesures de sécurité ci-dessus.
2. Mettre le thermostat à la position minimale.
3. Couper le courant électrique qui mène à l'appareil.
4. Cet appareil ménager étant doté d'un système d'allumage automatique, ne pas essayer d'allumer le brûleur manuellement.
5. Retirer le panneau/volet d'accès de commande (panneau supérieur s'il s'agit d'un modèle à deux panneaux).
6. Réglez l'interrupteur de commande du gaz à la position "OFF". (voir Figure 1).
7. Attendre cinq (5) minutes pour s'assurer de la dissipation du gaz. En cas d'odeur, ARRÊTER LE PROCÉDÉ. Suivre les instructions ci-dessus (Section B). En l'absence de toute odeur de gaz, avancer à l'étape suivante.
8. Réglez l'interrupteur de commande du gaz à la position "ON". (voir Figure 1).
9. Remettre le panneau/volet d'accès de commande en place (panneau supérieur s'il s'agit d'un modèle à deux panneaux).
10. Rebrancher l'appareil sur le réseau électrique.
11. Ajuster le thermostat à la position désirée.
12. Si l'appareil ne fonctionne pas, suivre les "Directives d'arrêt" cidessous et appeler le technicien de service.

## TO TURN OFF GAS TO APPLIANCE

1. Set the thermostat to the lowest setting.
2. Turn off all electrical power to the appliance if service is to be performed.
3. Remove the control access door/panel (upper door if two-door model).
4. Move the gas control switch to the "OFF" position. Do not use force. (See Figure 1)

## DIRECTIVES D'ARRÊT

1. Mettre le thermostat à la position minimale.
2. Débrancher l'appareil en prévision de la réparation.
3. Retirer le panneau/volet d'accès de commande (panneau supérieur s'il s'agit d'un modèle à deux panneaux).
4. Réglez l'interrupteur de commande du gaz à la position "OFF". Ne forcez pas. (voir Figure 1).

Figure 10. Gas Valve Label

## ELECTRICAL DATA & DIAGRAMS

Model Number	Heating Input (BTUh)	Nominal Electrical Supply	Voltage Range		Compressor		Fan Amps	Blower Motor Amps	Minimum Circuit Ampacity	Maximum Over-current Protection
			Min.	Max.	RLA	LRA				
024K	45,000	208/230-60-1	187	253	12.8	58.3	1.0	1.3	18.3	30
	72,000	208/230-60-1	187	253	12.8	58.3	1.0	1.3	18.3	30
030K	45,000	208/230-60-1	187	253	15.7	73.0	1.46	1.3	22.4	35
	72,000	208/230-60-1	187	253	15.7	73.0	1.46	1.3	22.4	35
036K	72,000	208/230-60-1	187	253	18.6	79.0	1.46	3.6	28.3	45
	96,000	208/230-60-1	187	253	18.6	79.0	1.46	3.6	28.3	45
042K	72,000	208/230-60-1	187	253	22.1	109.0	1.46	3.6	32.7	50
	96,000	208/230-60-1	187	253	22.1	109.0	1.46	3.6	32.7	50
048K	96,000	208/230-60-1	187	253	24.3	117.0	1.46	5.0	36.8	60
	120,000	208/230-60-1	187	253	24.3	117.0	1.46	5.0	36.8	60
X60K	96,000	208/230-60-1	187	253	29.3	134.0	1.5	6.5	44.6	70
	120,000	208/230-60-1	187	253	29.3	134.0	1.5	6.5	44.6	70

**NOTE:** FLA = Full Load Amps; LRA = Lock Rotor amps; RLA = Rated Load Amps.

**Table 11. Electrical Data.**

# WIRING DIAGRAM

## Packaged Single Stage Gas Heat/Electric Air Conditioner

208/230 Volt

Single Phase

60Hz

### NOTES:

1. Disconnect all power before servicing.
2. For supply connections use copper conductors only.
3. Not suitable on systems that exceed 150V to ground.
4. If any of the original wire as supplied with the furnace must be replaced, it must be replaced with wiring material having a temperature rating of at least 105 C.
5. For supply wire ampacities and overcurrent protection, see unit rating plate.

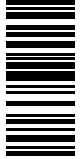
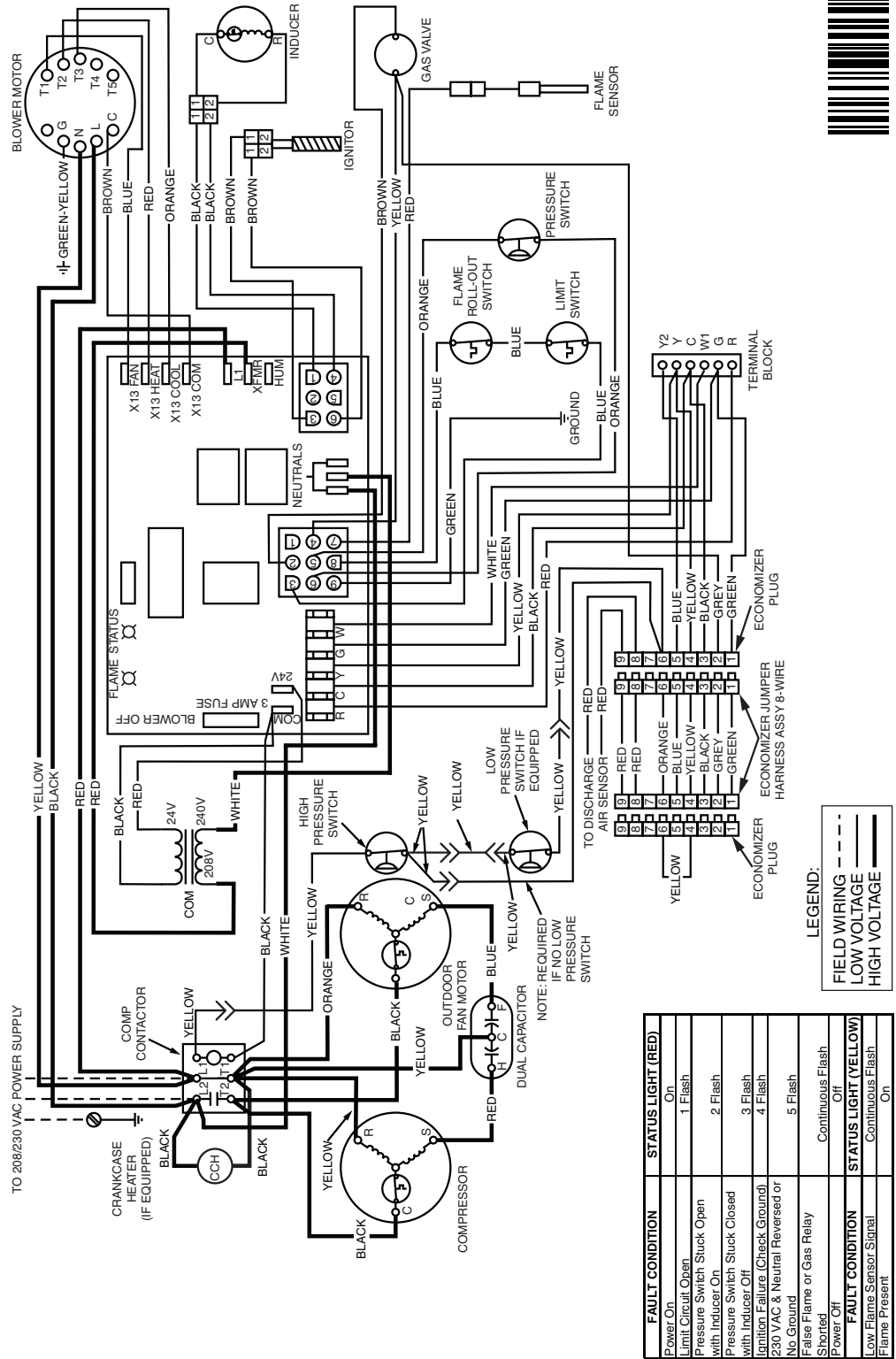

7111770  
12/11

Figure 11. Wiring Diagram for 208/230V / 60 Hz Unit with ECM Motor

# WIRING DIAGRAM

## Packaged Single Stage Gas Heat/Electric Air Conditioner

208/230 Volt

Single Phase 60Hz

- NOTES:**
1. Disconnect all power before servicing.
  2. For supply connections use copper conductors only.
  3. Not suitable on systems that exceed 150V to ground.
  4. If any of the original wire as supplied with the furnace must be replaced, it must be replaced with wiring material having a temperature rating of at least 105 C.

5. For supply wire ampacities and overcurrent protection, see unit rating plate.
6. Factory jumper wire is installed across HEAT and COOL when one blower speed is selected from both modes of operation.

1. Couper le courant avantaire letretien.
2. Employez uniquement des conducteurs en cuivre.
3. Ne convient pas aux installations de plus de 150V a la terre.

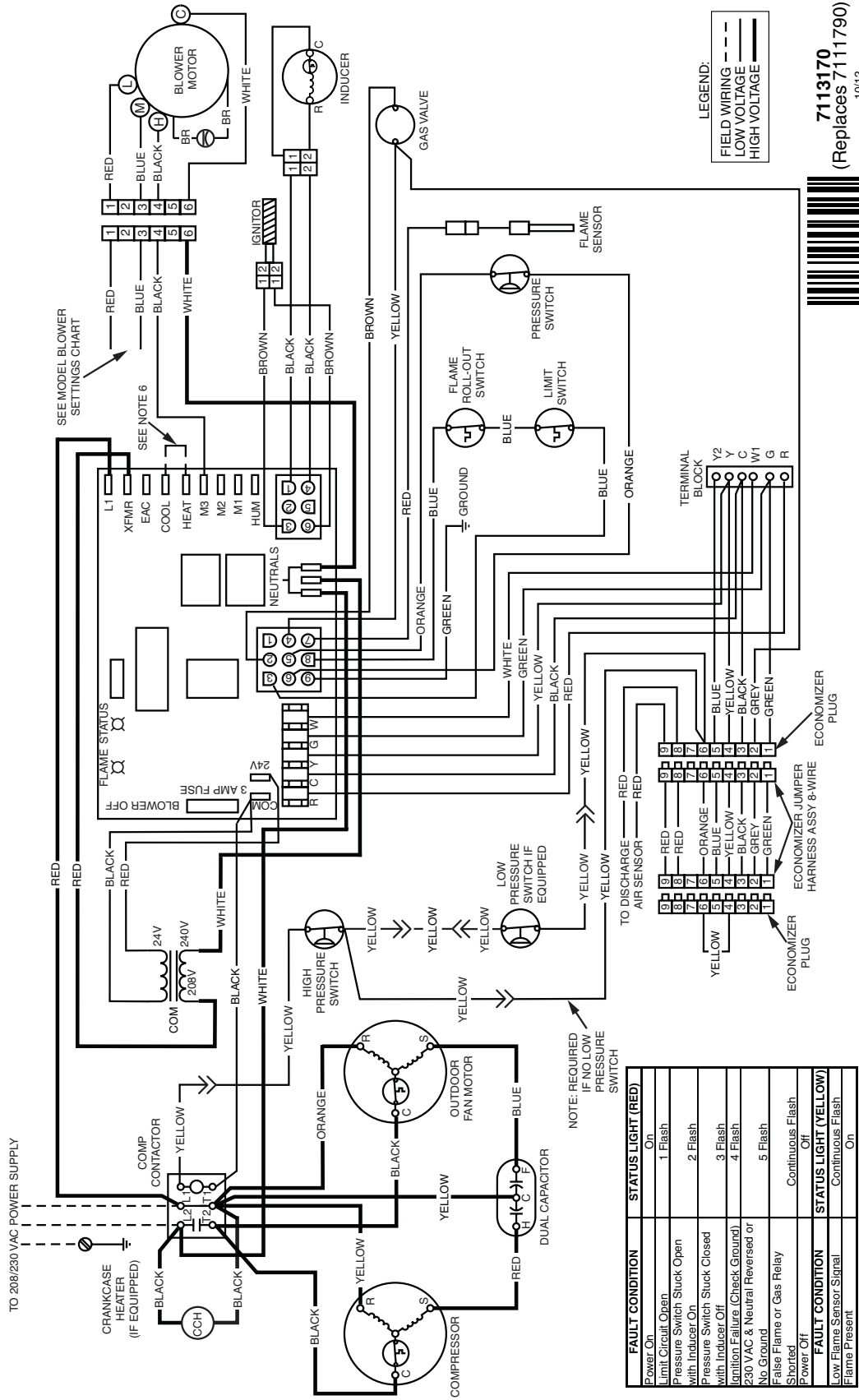

7113170  
(Replaces 7111790)  
10/12

Figure 12. Wiring Diagram for 208/230V / 60 Hz Unit with PSC Motor

**REFRIGERANT CHARGING TABLES - COOLING MODE**

 Shaded boxes indicate flooded conditions.

 Rated design values. The suction pressure will be lower than design value if indoor air flow, entering dry bulb, or entering wet bulb temperature are lower than design.

1. All pressures are listed psig and all temperatures in °F
2. Discharge temperatures greater than charted values indicate an undercharged system.

<b>2 TON MODELS</b>																
SUCT. PRESS.	OUTDOOR TEMPERATURE (°F)															
	70		75		80		85		90		95		100		105	
	Liq. PRESS.	Dis. TEMP.	Liq. PRESS.	Dis. TEMP.	Liq. PRESS.	Dis. TEMP.	Liq. PRESS.	Dis. TEMP.	Liq. PRESS.	Dis. TEMP.	Liq. PRESS.	Dis. TEMP.	Liq. PRESS.	Dis. TEMP.	Liq. PRESS.	Dis. TEMP.
134	236	130														
136	238	135	259	132												
138	240	140	261	137	282	135										
140	245	141	263	142	284	140	305	138								
142	249	143	268	144	286	145	307	143	328	141						
144			271	147	290	147	309	147	330	145	351	144				
146					294	151	313	151	332	150	353	148	374	147		
148							316	154	336	154	355	153	376	151	397	150
150							320	158	339	158	358	157	378	155	399	154
152									343	161	362	161	381	159	401	158
154											365	165	384	164	404	162
156													388	168	407	167
158															411	171
160																

**Table 12. Charging Table for 2 Ton Models (024K Series)**

<b>2.5 TON MODELS</b>																
SUCT. PRESS.	OUTDOOR TEMPERATURE (°F)															
	70		75		80		85		90		95		100		105	
	Liq. PRESS.	Dis. TEMP.	Liq. PRESS.	Dis. TEMP.	Liq. PRESS.	Dis. TEMP.	Liq. PRESS.	Dis. TEMP.	Liq. PRESS.	Dis. TEMP.	Liq. PRESS.	Dis. TEMP.	Liq. PRESS.	Dis. TEMP.	Liq. PRESS.	Dis. TEMP.
137	251	130														
139	253	135	272	134												
141	256	140	275	139	293	139										
143	260	142	277	144	296	143	315	143								
145	263	144	281	146	298	148	317	148	336	148						
147			284	149	302	151	319	152	338	152	357	152				
149					305	155	323	156	340	157	359	157	378	157		
151							326	159	344	160	361	161	380	161	399	162
153							330	163	347	164	364	165	382	165	401	165
155									350	168	368	169	385	169	403	169
157											371	173	389	173	406	174
159													392	178	410	178
161															413	182
163																

**Table 13. Charging Table for 2.5 Ton Models (030K Series)**

**REFRIGERANT CHARGING TABLES - COOLING MODE**

 Shaded boxes indicate flooded conditions.

 Rated design values. The suction pressure will be lower than design value if indoor air flow, entering dry bulb, or entering wet bulb temperature are lower than design.

1. All pressures are listed psig and all temperatures in °F
2. Discharge temperatures greater than charted values indicate an undercharged system.

<b>3 TON MODELS</b>																
SUCT. PRESS.	OUTDOOR TEMPERATURE (°F)															
	70		75		80		85		90		95		100		105	
	Liq. PRESS.	Dis. TEMP.	Liq. PRESS.	Dis. TEMP.	Liq. PRESS.	Dis. TEMP.	Liq. PRESS.	Dis. TEMP.	Liq. PRESS.	Dis. TEMP.	Liq. PRESS.	Dis. TEMP.	Liq. PRESS.	Dis. TEMP.	Liq. PRESS.	Dis. TEMP.
130	241	128														
132	243	134	265	132												
134	246	139	267	137	288	135										
136	250	140	269	142	291	140	312	138								
138	253	143	273	144	293	145	314	143	336	142						
140			277	147	297	147	316	147	338	146	360	145				
142					300	151	320	151	340	150	362	149	383	148		
144							324	154	344	154	364	153	385	152	407	152
146							327	158	347	158	367	157	387	156	409	156
148									350	162	370	162	390	161	411	160
150											374	166	394	165	414	164
152													397	169	417	168
154															421	173
156																

**Table 14. Charging Table for 3 Ton Models (036 Series)**

<b>3.5 TON MODELS</b>																
SUCT. PRESS.	OUTDOOR TEMPERATURE (°F)															
	70		75		80		85		90		95		100		105	
	Liq. PRESS.	Dis. TEMP.	Liq. PRESS.	Dis. TEMP.	Liq. PRESS.	Dis. TEMP.	Liq. PRESS.	Dis. TEMP.	Liq. PRESS.	Dis. TEMP.	Liq. PRESS.	Dis. TEMP.	Liq. PRESS.	Dis. TEMP.	Liq. PRESS.	Dis. TEMP.
123	249	136														
125	252	141	274	139												
127	254	146	276	144	298	143										
129	259	147	278	149	300	148	322	147								
131	262	149	282	151	302	153	324	151	346	150						
133			286	154	306	155	326	156	348	155	371	154				
135					310	158	330	159	350	159	373	159	395	158		
137							334	163	354	163	375	163	397	162	419	162
139							337	166	358	167	378	167	399	166	421	166
141									361	171	381	171	402	170	423	170
143											385	175	405	175	426	174
145													409	179	429	179
147															433	183
149																

**Table 15. Charging Table for 3.5 Ton Models (042 Series)**

**REFRIGERANT CHARGING TABLES - COOLING MODE**

 Shaded boxes indicate flooded conditions.

 Rated design values. The suction pressure will be lower than design value if indoor air flow, entering dry bulb, or entering wet bulb temperature are lower than design.

1. All pressures are listed psig and all temperatures in °F
2. Discharge temperatures greater than charted values indicate an undercharged system.

**4 TON MODELS**

SUCT. PRESS.	OUTDOOR TEMPERATURE (°F)																
	70		75		80		85		90		95		100		105		
	Liq. PRESS.	Dis. TEMP.	Liq. PRESS.	Dis. TEMP.	Liq. PRESS.	Dis. TEMP.	Liq. PRESS.	Dis. TEMP.	Liq. PRESS.	Dis. TEMP.	Liq. PRESS.	Dis. TEMP.	Liq. PRESS.	Dis. TEMP.	Liq. PRESS.	Dis. TEMP.	
124	253	142															
126	255	147	277	144													
128	257	152	279	149	301	147											
130	263	152	281	154	303	152	325	150									
132	266	154	286	155	305	157	327	155	349	153							
134			290	158	310	159	329	159	351	157	373	156					
136					313	162	333	162	353	162	375	160	397	159			
138							337	166	357	165	377	164	399	163	422	162	
140							340	169	361	169	381	168	401	167	423	166	
142									364	173	384	172	404	171	425	170	
144											388	177	408	176	428	174	
146													411	180	431	178	
148															435	183	
150																	

**Table 16. Charging Table for 4 Ton Models (048 Series)**

**5 Ton Charging Chart**

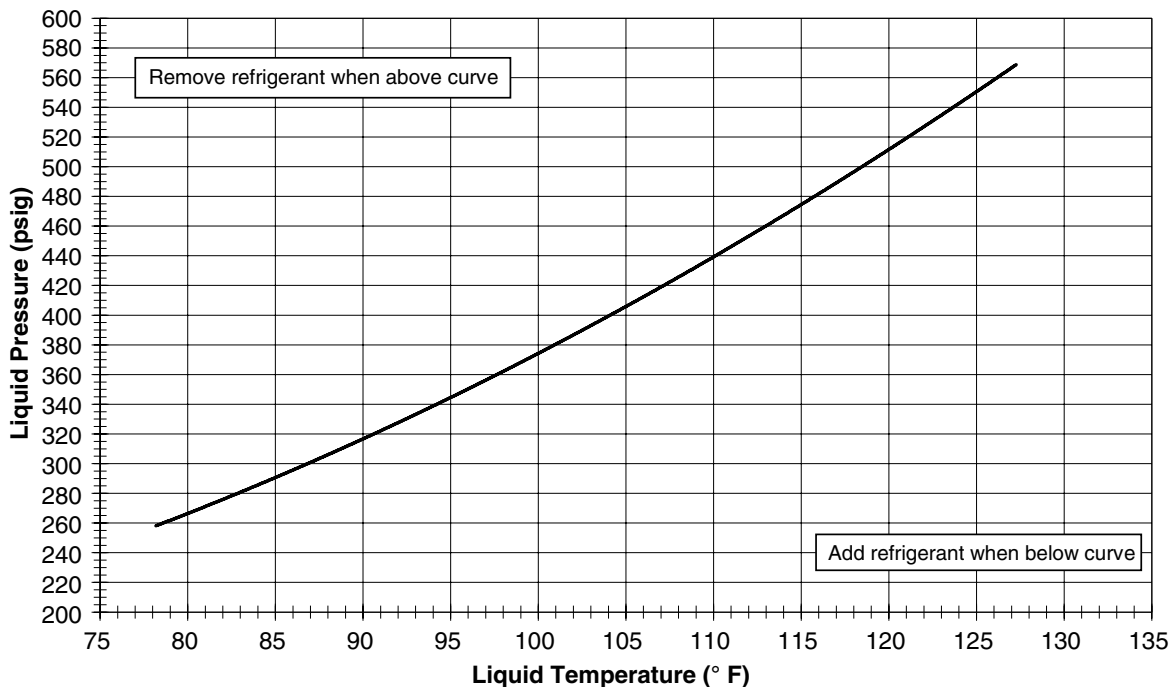

**Figure 13. Charging Chart for 5 Ton Models (X60K Series)**

## INSTALLATION / PERFORMANCE CHECK LIST

<b>INSTALLATION ADDRESS:</b>		
CITY _____	STATE _____	
UNIT MODEL # _____		
UNIT SERIAL # _____		
Unit Installed Minimum clearances per Figure 1 (page 5)?	YES	NO
<b>INSTALLER NAME:</b>		
CITY _____	STATE _____	
Has the owner's information been reviewed with the customer?	YES	NO
Has the Literature Package been left with the unit?	YES	NO

<b>ELECTRICAL SYSTEM</b>		
Electrical connections tight?	YES	NO
Line voltage polarity correct?	YES	NO
Rated Voltage: _____ VOLTS		
L1-L2 Volts: _____ VOLTS		
Has the thermostat been calibrated?	YES	NO
Is the thermostat level?	YES	NO
Is the heat anticipator setting correct?	YES	NO

<b>VENTING SYSTEM</b>		
Is the vent hood installed?	YES	NO
Is vent hood free from restrictions	YES	NO
Filter(s) secured in place?	YES	NO
Filter(s) clean?	YES	NO

<b>GAS SYSTEM</b>		
Gas Type: (circle one)	Natural Gas	Propane
Gas pipe connections leak-tested?	YES	NO
Gas Line Pressure: _____ (in - W.C.)		
Is there adequate fresh air supply for combustion and ventilation?	YES	NO
Installation Altitude: _____ (FT.)		
Deration Percentage: _____ (%)		
Unit Input: _____ (Btuh)		
Supply Air Temperature: _____ (° F)		
Return Air Temperature: _____ (° F)		
Temperature Rise: _____ (° F)		
<b>During Unit Operation:</b>		
Manifold pressure: _____ (in - W.C.)		

<b>REFRIGERATION SYSTEM</b>		
Was unit given 24 hr warm up period for crankcase heaters (if equipped)?	YES	NO
Stage-1 Liquid Pressure (high side) _____		
Stage-1 Suction Pressure (low side) _____		

### ATTENTION INSTALLERS:

It is your responsibility to know this product better than your customer. This includes being able to install the product according to strict safety guidelines and instructing the customer on how to operate and maintain the equipment for the life of the product. Safety should always be the deciding factor when installing this product and using common sense plays an important role as well. Pay attention to all safety warnings and any other special notes highlighted in the manual. Improper installation of the unit or failure to follow safety warnings could result in serious injury, death, or property damage. These instructions are primarily intended to assist qualified individuals experienced in the proper installation of this appliance. Some local codes require licensed installation/service personnel for this type of equipment.

