

# INSTALLATION INSTRUCTIONS

**\*SA(1,2)QD4M1 - (S,R)N24KA, (S,R)N30K, (S,R)N36K, SN42K, SN48K, & SN60K (2, 2.5, 3, 3.5, 4, & 5 TON) SERIES - SINGLE PHASE MODELS WITH QUICK CONNECT COUPLINGS**

<b>IMPORTANT SAFETY INFORMATION</b> .....	<b>2</b>
<b>AIR CONDITIONER INSTALLATION</b> .....	<b>3</b>
General Information .....	3
Before You Install this Unit.....	3
Locating the Air Conditioner.....	3
Packaging Removal.....	3
Ground Level .....	3
Roof Mount .....	3
Connecting Refrigerant Tubing Between the Indoor & Outdoor Unit.....	4
<b>ELECTRICAL WIRING</b> .....	<b>4</b>
Pre-Electrical Checklist.....	4
Line Voltage.....	4
Grounding.....	5
Thermostat / Low Voltage Connections .....	5
<b>START UP &amp; ADJUSTMENTS</b> .....	<b>5</b>
Pre-Start Check List.....	5
Start-Up Procedures .....	5
Air Circulation - Indoor Blower.....	5
System Cooling .....	5
System Heating (optional) .....	5
<b>AIR CONDITIONER MAINTENANCE</b> .....	<b>6</b>
Panel Removal.....	6
Panel Installation.....	6
<b>REFRIGERANT CHARGING</b> .....	<b>6</b>
Charging the Unit in AC mode .....	7
If the outdoor temperature is 65 degrees F or higher: .....	7
If the outdoor temperature is below 65 degrees F:.....	7
<b>COMPONENT FUNCTIONS</b> .....	<b>7</b>
<b>WIRING DIAGRAMS</b> .....	<b>8</b>
Figure 4. Wiring Diagram for *SA(1,2)QD4M1SN (2, 2.5, 3, 3.5, 4, & 5 Ton Units) .....	8
Figure 5. Wiring Diagram for *SA(1,2)QD4M1RN (2, 2.5, & 3 Ton Units) .....	9
<b>INSTALLATION CHECKLIST</b> .....	<b>12</b>
<b>REPLACEMENT PARTS</b> .....	<b>12</b>

## IMPORTANT

**ATTENTION INSTALLERS:**

It is your responsibility to know this product better than your customer. This includes being able to install the product according to strict safety guidelines and instructing the customer on how to operate and maintain the equipment for the life of the product. Safety should always be the deciding factor when installing this product and using common sense plays an important role as well. Pay attention to all safety warnings and any other special notes highlighted in the manual. Improper installation of the unit or failure to follow safety warnings could result in serious injury, death, or property damage.

These instructions are primarily intended to assist qualified individuals experienced in the proper installation of this appliance. Some local codes require licensed installation/service personnel for this type of equipment. Please read all instructions carefully before starting the installation. Return these instructions to the customer's package for future reference.

**DO NOT DESTROY. PLEASE READ CAREFULLY & KEEP IN A SAFE PLACE FOR FUTURE REFERENCE.**

## IMPORTANT SAFETY INFORMATION

**INSTALLER:** Please read all instructions before servicing this equipment. Pay attention to all safety warnings and any other special notes highlighted in the manual. Safety markings are used frequently throughout this manual to designate a degree or level of seriousness and should not be ignored. **WARNING** indicates a potentially hazardous situation that if not avoided, could result in personal injury or death. **CAUTION** indicates a potentially hazardous situation that if not avoided, may result in minor or moderate injury or property damage.

### **WARNING:**

#### **ELECTRICAL SHOCK OR FIRE HAZARD**

To avoid risk of electrical shock, personal injury, or death, disconnect all electrical power to the unit before performing any maintenance or service. The unit may have more than one electrical supply.

Label all wires prior to disconnection when servicing the unit. Wiring errors can cause improper and dangerous operation

### **WARNING:**

Unless noted otherwise in these instructions, only factory authorized parts or accessory kits may be used with this product. Improper installation, service, adjustment, or maintenance may cause explosion, fire, electrical shock or other hazardous conditions which may result in personal injury or property damage.

### **WARNING:**

SA1QD4M1SN split system air conditioners are shipped fully charged with R410A refrigerant and ready for installation. When system is installed according to these instructions, no refrigerant charging is required. If repairs make it necessary for evacuation and charging, it should only be attempted by qualified trained personnel thoroughly familiar with this equipment. Under no circumstances should the owner attempt to install and/or service this equipment. Failure to comply with this warning could result in property damage, personal injury, or death.

### **CAUTION:**

**This unit uses refrigerant R-410A. DO NOT use any other refrigerant in this unit. Use of another refrigerant will damage the unit.**

### **WARNING:**

The information listed below must be followed during the installation, service, and operation of this unit. Unqualified individuals should not attempt to interpret these instructions or install this equipment. Failure to follow safety recommendations could result in possible damage to the equipment, serious personal injury or death.

- The installer must comply with all local codes and regulations which govern the installation of this type of equipment. Local codes and regulations take precedence over any recommendations contained in these instructions. Consult local building codes and the National Electrical Code (ANSI C1) for special installation requirements.
- All electrical wiring must be completed in accordance with local, state and national codes and regulations and with the National Electric Code (ANSI/NFPA 70) or in Canada the Canadian Electric Code Part 1 CSA C.22.1.
- This equipment contains liquid and gaseous refrigerant under high pressure. **DO NOT USE ANY PORTION OF THE CHARGE FOR PURGING OR LEAK TESTING.** Installation or servicing should only be performed by qualified trained personnel thoroughly familiar with this type equipment.
- Refrigerant suction line tubing should be fully insulated.
- Installation of equipment should not require brazing operations. However, if brazing does become necessary, the installer should comply with safety codes and wear appropriate safety equipment (safety glasses, work gloves, fire extinguisher, etc.) when performing brazing operations.
- Follow all precautions in the literature, on tags, and on labels provided with the equipment. Read and thoroughly understand the instructions provided with the equipment prior to performing the installation and operational checkout of the equipment.
- This unit is designed for outdoor installations only and should be positioned as shown on [page 3](#).
- Refrigerant and electrical line should be routed through suitably waterproofed openings to prevent water from leaking into the structure.
- Use caution when handling this appliance or removing components. Personal injury can occur from sharp metal edges present in all sheet metal constructed equipment.

## AIR CONDITIONER INSTALLATION

### General Information

The SA(1,2)QD4M series air conditioner is designed only for outdoor rooftop or ground level installations. This unit has been tested for capacity and efficiency in accordance with AHRI Standards and will provide many years of safe and dependable comfort, providing it is properly installed and maintained. Abuse, improper use, and/or improper maintenance can shorten the life of the appliance and create unsafe hazards.

To achieve optimum performance and minimize equipment failure, it is recommended that periodic maintenance be performed on this unit. The ability to properly perform maintenance on this equipment requires certain mechanical skills and tools.

### Before You Install this Unit

- ✓ The cooling load of the area to be conditioned must be calculated and a system of the proper capacity selected. It is recommended that the area to be conditioned be completely insulated and vapor sealed.
- ✓ Check the electrical supply and verify the power supply is adequate for unit operation. The system must be wired and provided with circuit protection in accordance with local building codes. If there is any question concerning the power supply, contact the local power company.
- ✓ The indoor section (air handler, furnace, etc) should be installed before routing the refrigerant tubing. Refer to the indoor unit's installation instructions for installation details.
- ✓ All units are securely packed at the time of shipment and upon arrival should be carefully inspected for damage prior to installing the equipment at the job site. Verify coil fins are straight. Claims for damage (apparent or concealed) should be filed immediately with the carrier.
- ✓ Please consult your dealer for maintenance information and availability of maintenance contracts. Please read all instructions before installing the unit.

### Locating the Air Conditioner

- Survey the job site to determine the best location for mounting the outdoor unit.
- The outdoor unit should be installed no closer than 18 inches from the outside walls of the facility and in an area free from overhead obstructions to ensure unrestricted airflow through the outdoor unit.
- Sufficient clearance for unobstructed airflow through the outdoor coil must be maintained in order to achieve rated performance. For minimum clearances to obstructions, see Figure 1.
- Overhead obstructions (Figure 1), poorly ventilated areas, and areas subject to accumulation of debris should be avoided.
- Consideration should be given to availability of electric power, service access, noise, and shade.

### Packaging Removal

**NOTE:** To prevent damage to the tubing connections, carefully remove the carton and user's manual from the equipment. Discard the shipping carton.

### Ground Level

Ground level installations must be located according to local building codes or ordinances and these requirements:

- Clearances must be in accordance with those shown in Figure 1.
- A suitable mounting pad must be provided and separate from the building foundation. The pad must be level and strong enough to support the weight of the unit. The slab height must be a minimum of 2" (5 cm) above grade and with adequate drainage. See Figure 1.

### Roof Mount

- The method of mounting should be designed so that it does not overload roof structures or transmit noise to the interior of the structure. The roof must be structurally capable of handling the weight of the unit.
- Full perimeter support is required under the unit. Support must be made of weather resistant materials and installed prior to unit installation.
- The support must be built to raise the unit 6" above the roof.

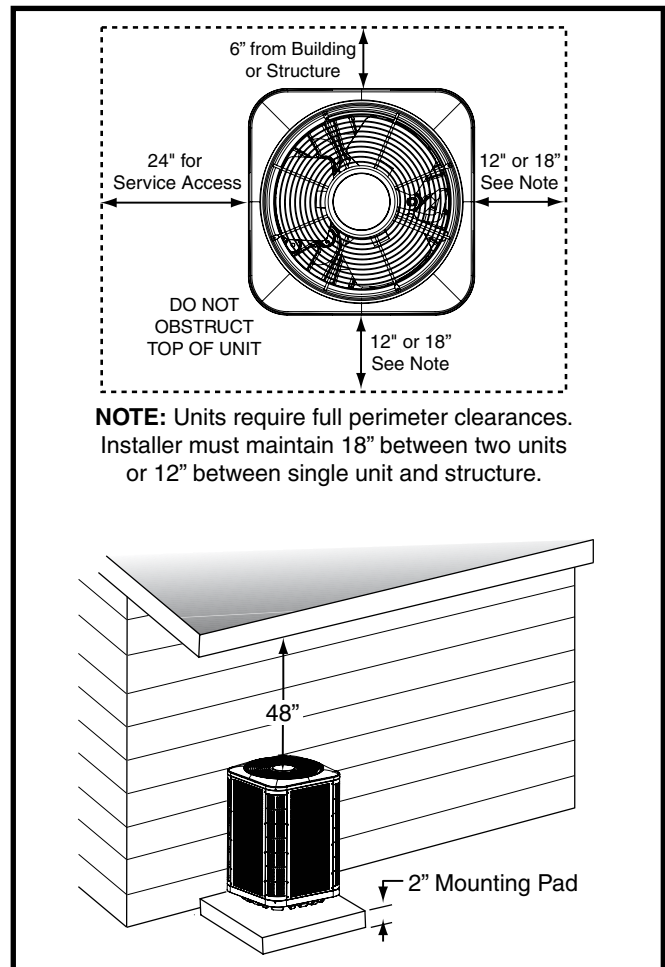

Figure 1. Clearance Requirements

## Connecting Refrigerant Tubing Between the Indoor & Outdoor Unit

### **CAUTION:**

**When servicing, cover or seal openings to minimize the exposure of the refrigerant system to air to prevent accumulation of moisture and other contaminants.**

After outdoor and indoor unit placement has been determined, route refrigerant tubing between the equipment in accordance with sound installation practices.

- Refrigerant tubing should be routed in a manner that minimizes the length of tubing and the number of bends in the tubing. If precise forming of refrigerant lines is required, a copper tubing bender is recommended. Avoid sharp bends and contact of the refrigerant lines with metal surfaces.
  - Refrigerant tubing should be supported in a manner that the tubing will not vibrate or abrade during system operation.
  - Tubing should be kept clean of foreign debris during installation.
  - A filter dryer is factory installed in the outdoor unit.
  - Every effort should be made by the installer to ensure that the field installed refrigerant containing components of the system have been installed in accordance with these instructions and sound installation practices to insure reliable system operation and longevity.
  - The maximum recommended interconnecting refrigerant line lengths is 75 ft. and the vertical elevation difference between the indoor and outdoor sections should not exceed 20 ft.
  - Optional equipment such as liquid line solenoid valves, low ambient, etc., should be installed in strict accordance with the manufacturer's installation instructions.
  - These units are equipped with single shot quick connect couplings. Together with the indoor section and line set, only four coupling connections are required to provide a 100% sealed system.
1. Route the suction line and liquid line between indoor and outdoor sections, remove protector caps and plugs.
  2. With a soft, dust-free cloth, carefully wipe clean all coupling threads and seals to remove any dust or material which could contaminate the refrigerant system.
  3. Using refrigerant oil, lightly lubricate the diaphragm, o-ring, and mating threads.
  4. Connect the couplings as follows:
    - a.) Line up the refrigerant line with the coil coupling and thread together by hand for 2-3 turns of the union nut (or until a sharp increase in torque is felt), to ensure proper thread mating.
    - b.) With the appropriate sized wrenches, tighten the union nut while preventing rotation of the female body with respect to the male half. Tighten the nut to the appropriate value in [Table 1](#).
  5. Using a marker, mark a line from the coupling union nut to the bulkhead then tighten an additional wrench flat (60°). Repeat for all couplings.
  6. Check the system for leaks.

COUPLING SIZE	TORQUE	MALE COUPLING	FEMALE COUPLING NUT	FEMALE COUPLING BODY
3/8" (10mm)	10-12 Ft-Lbs (14-16 Nm)	3/4"	13/16"	5/8"
3/4" (19mm)	35-45 Ft-Lbs (47-61 Nm)	1-1/16"	1-5/16"	1"
7/8" (22mm)	35-45 Ft-Lbs (47-61 Nm)	1-1/8"	1-5/16"	1"

**Table 1. Torque Values**

## ELECTRICAL WIRING

### **WARNING:**

#### **ELECTRICAL SHOCK OR FIRE HAZARD**

**To avoid risk of electrical shock, personal injury, or death, disconnect all electrical power to the unit before performing any maintenance or service. The unit may have more than one electrical supply.**

**Label all wires prior to disconnection when servicing the unit. Wiring errors can cause improper and dangerous operation**

- All electrical connections must be in compliance with all applicable local codes and ordinances, and with the current revision of the National Electric Code (ANSI/NFPA 70).
- For Canadian installations the electrical connections and grounding shall comply with the current Canadian Electrical Code (CSA C22.1 and/or local codes).

#### **Pre-Electrical Checklist**

- ✓ Verify that the voltage, frequency, and phase of the supply source match the specifications on the unit rating plate.
- ✓ Verify that the service provided by the utility is sufficient to handle the additional load imposed by this equipment. Refer to the unit wiring label for proper voltage wiring.
- ✓ Verify factory wiring is in accordance with the unit wiring diagram. Inspect for loose connections. See [Figure 4 \(page 8\)](#) and [Figure 5 \(page 9\)](#).

#### **Line Voltage**

- A wiring diagram is located on the inside cover of the electrical box of the outdoor unit. The installer should become familiar with the wiring diagram before making any electrical connections to the outdoor unit.
- **An electrical disconnect must be located within sight of and readily accessible to the unit.** This switch shall be capable of electrically de-energizing the outdoor unit.
- Line voltage to the unit should be supplied from a dedicated branch circuit containing the correct fuse or circuit breaker for the unit. Incoming field wiring and minimum size of electrical conductors and circuit protection must be in compliance with information listed on the outdoor unit data label. Any other wiring methods must be acceptable to authority having jurisdiction.
- The outdoor unit requires both power and control circuit electrical connections. Refer to the wiring diagram [Figure 4 \(page 8\)](#) and [Figure 5 \(page 9\)](#) for identification and location of outdoor unit field wiring interfaces. Make

all electrical connections in accordance with all applicable codes and ordinances.

- Overcurrent protection must be provided at the branch circuit distribution panel and sized as shown on the unit rating label and according to applicable local codes. See the unit rating plate for minimum circuit ampacity and maximum overcurrent protection limits.
- Provide power supply for the unit in accordance with the unit wiring diagram, and the unit rating plate. Connect the line-voltage leads to the terminals on the contactor inside the control compartment.
- Use only copper wire for the line voltage power supply to this unit in strict accordance of the NEC (ANSI/NFPA 70), applicable local codes, and the instructions provided with the equipment. Use proper code agency listed conduit and a conduit connector for connecting the supply wires to the unit. Use of rain tight conduit is recommended.
- 208/230 Volt units are shipped from the factory wired for 230 volt operation. For 208V operation, remove the lead from the transformer terminal marked 240V and connect it to the terminal marked 208V.
- Optional equipment requiring connection to the power or control circuits must be wired in strict accordance of the NEC (ANSI/NFPA 70), applicable local codes, and the instructions provided with the equipment.

## Grounding

---

### **WARNING:**

---

**The unit cabinet must have an uninterrupted or unbroken electrical ground to minimize personal injury if an electrical fault should occur. Do not use gas piping as an electrical ground!**

---

This unit must be electrically grounded in accordance with local codes or, in the absence of local codes, with the National Electrical Code (ANSI/NFPA 70) or the CSA C22.1 Electrical Code. Use the grounding lug provided in the control box for grounding the unit.

## Thermostat / Low Voltage Connections

- Thermostat connections should be made in accordance with the instructions supplied with the thermostat and the indoor equipment.
- The outdoor unit is designed to operate from a 24 VAC Class II control circuit. The control circuit wiring must comply with the current provisions of the NEC (ANSI/NFPA 70) and with applicable local codes having jurisdiction.
- The low voltage wires must be properly connected to the units low voltage terminal block.
- The thermostat should be mounted about 5 feet above the floor on an inside wall. DO NOT install the thermostat on an outside wall or any other location where its operation may be adversely affected by radiant heat from fireplaces, sunlight, or lighting fixtures, and convective heat from warm air registers or electrical appliances. Refer to the thermostat manufacturer's instruction sheet for detailed mounting and installation information.

## START UP & ADJUSTMENTS

### Pre-Start Check List

- ✓ Verify the indoor unit is level and allows proper condensate drainage.
- ✓ Verify the outdoor coil and top of the unit are free from obstructions and debris, and all equipment access/control panels are in place.
- ✓ Verify air filters are cleaned and properly installed.
- ✓ Verify duct work is sealed to prevent air leakage.
- ✓ Verify line voltage power leads are securely connected and the unit is properly grounded.
- ✓ Verify low voltage wires are securely connected to the correct leads on the low voltage terminal strip.
- ✓ Verify power supply branch circuit overcurrent protection is sized properly.
- ✓ Verify the thermostat is wired correctly.

### Start-Up Procedures

The thermostat's function mode should be set to OFF and the fan mode should be set to AUTO. Close all electrical disconnects to energize the system.

#### *Air Circulation - Indoor Blower*

1. Set the thermostat system mode on OFF and the fan mode to ON.
2. Verify the blower runs continuously. Check the air delivery at the supply registers and adjust register openings for balanced air distribution. If insufficient air is detected, examine ductwork for leaks or obstructions.
3. Set the thermostat fan mode to AUTO and verify the blower stops running.

#### *System Cooling*

1. Set the thermostat's system mode to COOL and the fan mode to AUTO. Gradually lower the thermostat temperature setpoint below room temperature and verify the outdoor unit and indoor blower energize.
  2. Verify blower wheel is spinning in direction indicated by arrow. Feel the air being circulated by the indoor blower and verify that it is cooler than ambient temperature. Listen for any unusual noises. If unusual sounds occur, determine the source of the noise and correct as necessary.
  3. Verify HI and LO refrigerant pressures.
  4. Allow the system to operate for several minutes and then set the temperature selector above room temperature. Verify the fan and compressor cycle off with the thermostat.
- NOTE:** The blower should also stop unless fan mode is set to the ON position.

#### *System Heating (optional)*

1. Set the thermostat's system mode to HEAT and the temperature mode above room temperature.
2. Verify the optional heating equipment (furnace or electric heat) and indoor blower energize. Feel the air being circulated by the indoor blower and verify that it is warmer than ambient temperature. Listen for any unusual noises. If unusual sounds occur, determine the source of the noise and correct as necessary.

## AIR CONDITIONER MAINTENANCE

### **WARNING:**

To prevent electrical shock, personal injury, or death, disconnect all electrical power to the unit before performing any maintenance or service. The unit may have more than one electrical supply.

Proper maintenance is important to achieve optimum performance from the air conditioner. The ability to properly perform maintenance on this equipment requires certain mechanical skills and tools. If you do not possess these skills, contact your dealer for maintenance. Consult your local dealer about the availability of maintenance contracts. Routine maintenance should include the following:

- Inspect and clean or replace air filters at the beginning of each heating and cooling season, or more frequently if required.
- Inspect the condensate drain and outdoor coil at the beginning of each cooling season. Remove any debris. Clean the outdoor coil and louvers as necessary using a mild detergent and water. Rinse thoroughly with water.
- Inspect the electrical connections for tightness at the beginning of each heating and cooling season. Service as necessary.

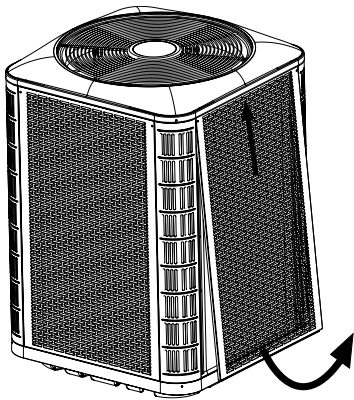

Figure 2. Panel Removal

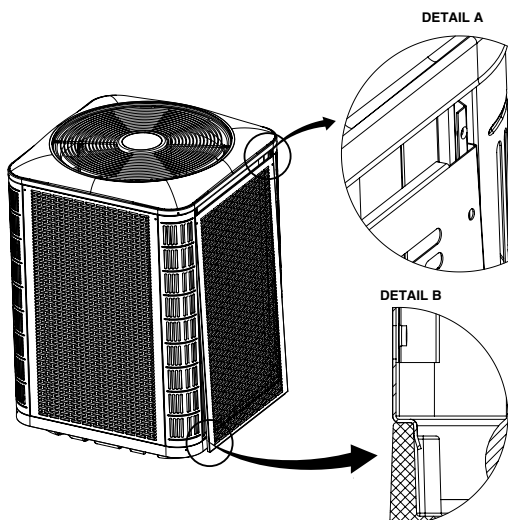

Figure 3. Panel Installation

### **CAUTION:**

The unit should never be operated without a filter in the return air system. Replace disposable filters with the same type and size.

- Do not add additional oil to motors unequipped with oil tubes. The compressor is hermetically sealed at the factory and does not require lubrication.

#### Panel Removal

1. Remove screws securing the panel.
2. Slide the panel up towards the top pan in order to clear the bottom flange from the base pan. See [Figure 2](#).
3. Swing the bottom of the panel out and pull the panel down to remove it from the unit.

#### Panel Installation

1. Insert the top corners of side panel flanges into the corner post channels as shown in [Detail A](#) in [Figure 3](#).
2. Slide the panel up into the top pan. (You may need to push on the center of the panel at the top in order to clear the top pan edge).
3. Swing the panel in and push down until the panel is resting on the top edge of the base pan wall as shown in [Detail B](#).
4. Install screws into the panel to secure it to the unit.

## REFRIGERANT CHARGING

### **WARNING:**

SA(1,2)QD4M split system air conditioners are shipped fully charged with R410A refrigerant and ready for installation. When system is installed according to these instructions, no refrigerant charging is required. If repairs make it necessary for evacuation and charging, it should only be attempted by qualified trained personnel thoroughly familiar with this equipment. Under no circumstances should the owner attempt to install and/or service this equipment. Failure to comply with this warning could result in property damage, personal injury, or death.

- After refrigerant line connections are completed, it is required that you leak check all line connections (using proper methods) before finalizing the full system refrigerant charge.
- To achieve rated capacity and efficiency, the compressor must be exposed to refrigerant for at least 24 hours prior to running and then the compressor must be run for a minimum of 12 hours.
- Refer to the unit's Quick Reference Data sheet to determine if additional refrigerant will need to be weighed-in to attain the base refrigerant amount for the system match that is being installed. Please note that the charge additions provided in the QRD are estimates based on test data and should only be used as a starting point. Complete the steps in the charging procedure to obtain the final system charge.
- Use of SA1QD4M1SN outdoor units with non-AHRI listed indoor coils is not recommended. Deviations from

rated airflows or non-listed combinations may require modification to the expansion device and refrigerant charging procedures for proper and efficient system operation.

- The refrigerant charge can be checked and adjusted through the service ports provided external to the outdoor unit. Use only gage line sets which have a “Schrader” depression device present to actuate the valve.
- A high-pressure switch is factory-installed and located in the compressor discharge line internal to the outdoor unit. The switch is designed to de-energize the system when very high pressures occur during abnormal conditions. Under normal conditions, the switch is closed. If the discharge pressure rises above 575 psig, then the switch will open and de-energize the outdoor unit. The switch will close again once the liquid pressure decreases to 460 psig. Please note that the switch interrupts the thermostat inputs to the unit. When the switch opens and then closes, there will be a 5 minute short cycling delay before the outdoor unit will energize.

### Charging the Unit in AC mode

**NOTE:** Quick connect air conditioners are shipped fully charged with R410A refrigerant and ready for installation and in normal circumstances no refrigerant charging is required. The instructions below are for use if refrigerant charging is necessary during later service calls.

*If the outdoor temperature is 65 degrees F or higher:*

After completing the refrigerant line connections, leak checking the system, and evacuating the indoor section and all line connections (using proper methods), perform the following steps:

1. Determine the recommended charge addition (if applicable) for the system being installed. This information is in the unit’s QRD (Quick Reference Data sheet).
2. Calculate the amount of additional refrigerant needed for the line set length of the actual installation. This information is on the first page of the unit’s QRD (Quick Reference Data sheet).
3. Weigh in the additional charge amounts determined by step 1 and 2 above.
4. Adjust the charge to match the superheat (for fixed orifice systems) or subcooling (for TXV systems). There are three different resources for doing this:
  - a.) The [chargecalculator.com](http://chargecalculator.com) website. This will walk you through the charging process step by step.
  - b.) The charging tables on the inside of the outdoor unit’s electrical box cover panel. These tables provide superheat targets for fixed orifice systems and subcooling targets for TXV systems. The system should be charged so that the measured superheat/subcooling are within 1 degree F of the target listed in the table.

### For fixed orifice systems:

- If your measured superheat at the suction valve is **LESS THAN** the recommended superheat value in the table then **REMOVE** refrigerant.
- If your measured superheat at the suction valve is **GREATER THAN** the recommended superheat value in the table then **ADD** refrigerant.

### For TXV systems:

- If your measured subcooling at the liquid valve is **LESS THAN** the recommended subcooling value in the table then **ADD** refrigerant.
  - If your measured subcooling at the liquid valve is **GREATER THAN** the recommended subcooling value in the table then **REMOVE** refrigerant.
- c.) The charging tables in the Supplemental Charging Information, can be found online in the literature library. The tables can also be accessed by scanning the QR code on the unit’s electrical panel. The pressures listed in these tables are for reference only and are to be used in troubleshooting a system. **The system should be charged to match the superheat or subcooling targets as previously noted and not to match the system pressures.** Follow the same procedure described in 4b above.

*If the outdoor temperature is below 65 degrees F:*

After completing the refrigerant line connections, leak checking the system, and evacuating the indoor section and all line connections (using proper methods), perform the following steps:

1. Determine the recommended charge addition (if applicable) for the system being installed. This information is in the unit’s QRD (Quick Reference Data sheet).
2. Calculate the amount of additional refrigerant needed for the line set length of the actual installation. This information is on the first page of the unit’s QRD (Quick Reference Data sheet).
3. Weigh in the additional charge amounts determined by steps 1 and 2 above.
4. Return to the system when the outdoor temperature is 65 degrees F or higher and follow the steps defined in step 4 of the “If the outdoor temperature is 65 degrees F or higher” section above.

## COMPONENT FUNCTIONS

**High Pressure Switch (HPS)** - A high-pressure switch is factory-installed and located in the liquid line internal to the outdoor unit. The switch is designed to protect the system when very high pressures occur during abnormal conditions. Under normal conditions, the switch is closed. If the liquid pressure rises above 575 psig, then the switch will open and de-energize the outdoor unit. The switch will close again once the liquid pressure decreases to 460 psig. Please note that the switch interrupts the thermostat inputs to the unit. Thus, when the switch opens and then closes, there may be a 5 minute short cycling delay before the outdoor unit will energize.

**Low-Pressure Switch** - (Select Models) A low-pressure switch is factory-installed and located in the suction line internal to the outdoor unit. The switch is designed to protect the compressor from a loss of charge. Under normal conditions, the switch is closed. If the suction pressure falls below 5 psig, then the switch will open and de-energize the outdoor unit. The switch will close again once the suction pressure increases above 20 psig. Please note that the switch interrupts the thermostat inputs to the unit. When the switch opens and then closes, there will be a 5 minute short cycling delay before the outdoor unit will energize.

WIRING DIAGRAMS

# WIRING DIAGRAM

## Split System Air Conditioner (Outdoor Section)

## Single Phase

**NOTES:**

1. Disconnect all power before servicing.
2. For supply connections use copper conductors only.
3. Not suitable on systems that exceed 150 volts to ground.
4. For replacement wires use conductors suitable for 105 deg C.
5. For ampacities and overcurrent protection, see unit rating plate.
6. Connect to 24 vac/40ca/class 2 circuit. See furnace/airhandler installation instructions for control circuit and optional relay/transformer kits.
7. Anti-Short Cycle Timer (ASCT) may or may not be installed in the unit. If desired, ASCT is factory installed on select models only or may be field installed as shown using manufacturer's approved kit. If not present, connect Yellow and Black wires per Note 6.

1. Couper le courant avant de faire letretien.
2. Employez uniquement des conducteurs en cuivre.
3. Ne convient pas aux installations de plus de 150 volt a la terre.

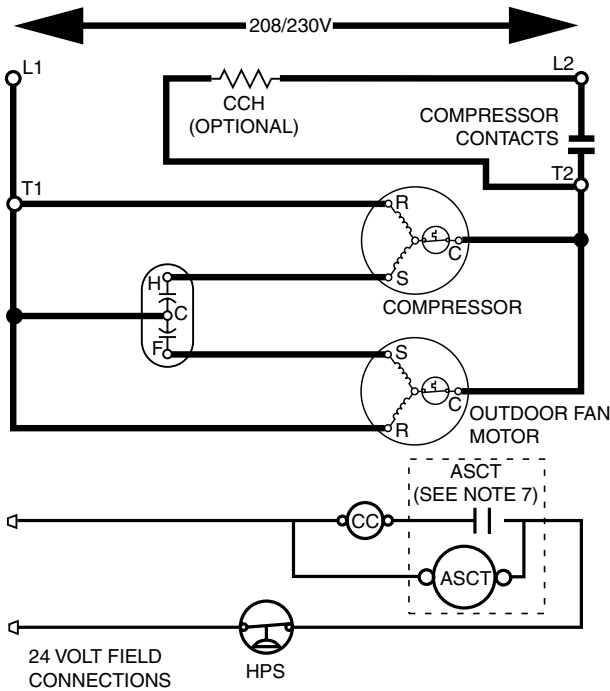

LEGEND:

CC - Contactor Coil	FIELD WIRING	---
CCH - Crankcase Heater	LOW VOLTAGE	----
HPS - High Pressure Switch	HIGH VOLTAGE	_____

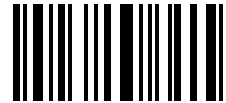
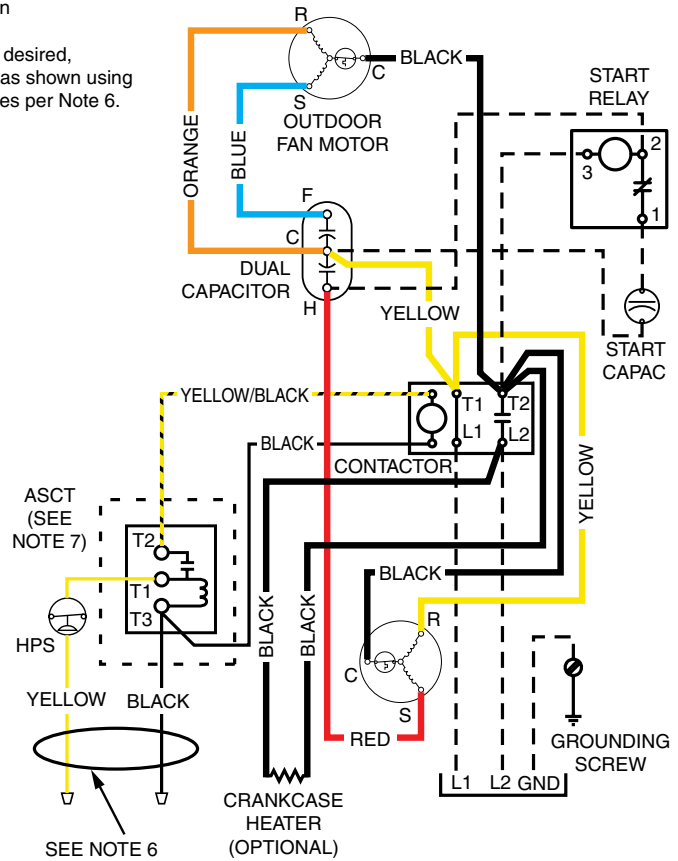

**710388C**  
(Replaces 710388B)

7/19

Figure 4. Wiring Diagram for \*SA(1,2)QD4M1SN (2, 2.5, 3, 3.5, 4, & 5 Ton Units)

# WIRING DIAGRAM

## Split System Air Conditioner (Outdoor Section)

## Single Phase

### NOTES:

1. Disconnect all power before servicing.
2. For supply connections use copper conductors only.
3. Not suitable on systems that exceed 150 volts to ground.
4. For replacement wires use conductors suitable for 105 deg C.
5. For ampacities and overcurrent protection, see unit rating plate.
6. Connect to 24 vac/40ca/class 2 circuit. See furnace/airhandler installation instructions for control circuit and optional relay/transformer kits.
7. Anti-Short Cycle Timer (ASCT) may or may not be installed in the unit. If desired, ASCT is factory installed on select models only or may be field installed as shown using manufacturer's approved kit. If not present, connect Yellow and Black wires per Note 6.
8. DO NOT use a Hard Start Kit on a model with a PTCR installed.

1. Couper le courant avant de faire le r tretien.
2. Employez uniquement des conducteurs en cuivre.
3. Ne convient pas aux installations de plus de 150 volt a la terre.

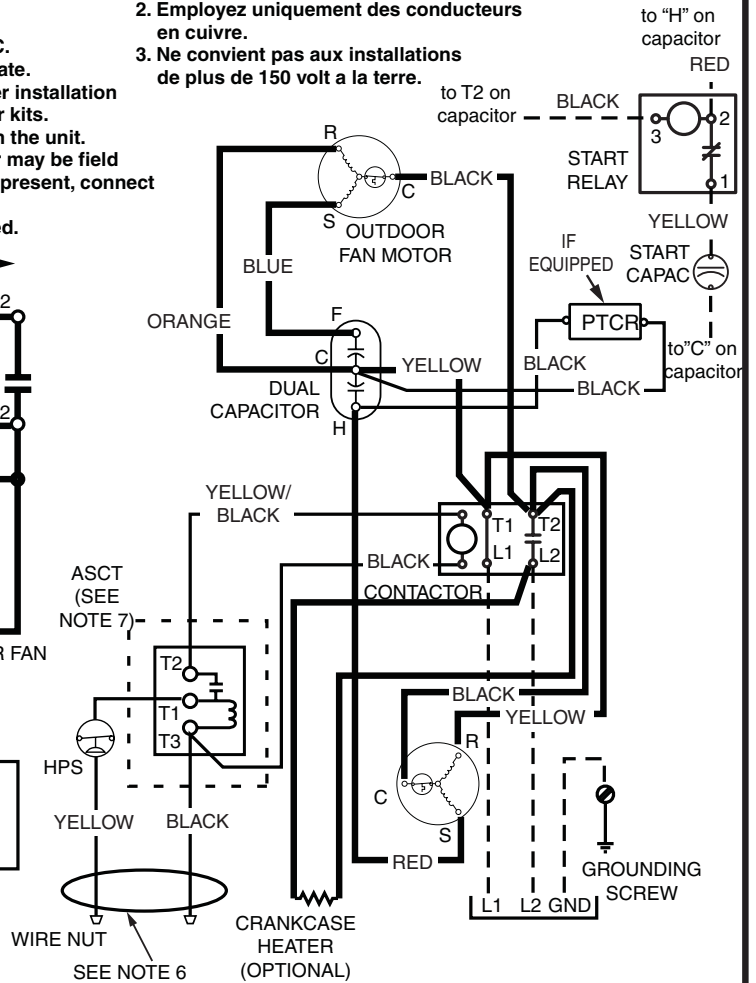
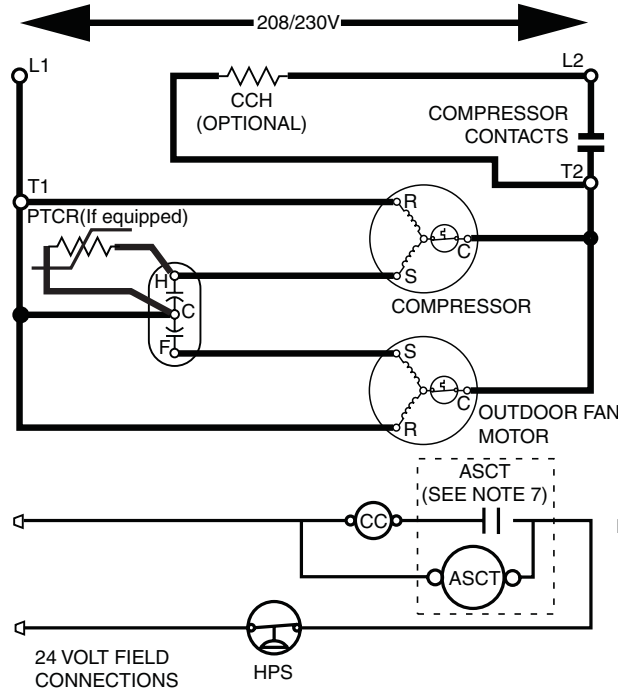

CC - Contactor Coil  
 CCH - Crankcase Heater  
 HPS - High Pressure Switch

**LEGEND:**

FIELD WIRING	----
LOW VOLTAGE	————
HIGH VOLTAGE	————

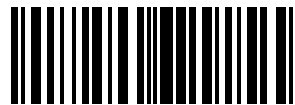

**10215960**  
 (Replaces 7110050)  
 5/18

Figure 5. Wiring Diagram for \*SA(1,2)QD4M1RN (2, 2.5, & 3 Ton Units)





## INSTALLATION CHECKLIST

<b>INSTALLATION ADDRESS:</b>		
CITY:	STATE:	
UNIT MODEL #		
UNIT SERIAL #		
<b>INSTALLER NAME:</b>		
CITY:	STATE:	
Unit installed minimum clearances shown on <a href="#">page 3</a> ?	YES	NO
Has the owner's information been reviewed with the customer?	YES	NO
Has the literature package been left with the unit?	YES	NO

ELECTRICAL SYSTEM		
Electrical connections tight?	YES	NO
Line voltage polarity correct?	YES	NO
Rated Voltage:		
Max. deviation of voltage from avg. volts:		
Has the thermostat been calibrated?	YES	NO
Is the thermostat level?	YES	NO
Is the heat anticipator setting correct? (If Applicable)	YES	NO

REFRIGERATION SYSTEM		
Was unit given 24 hr warm up period for crankcase heaters?	YES	NO
Stage-1 Liquid Pressure (high side):		
Stage-1 Suction Pressure (low side):		



### REPLACEMENT PARTS

Replacement parts are available through your distributor. Please have the complete model and serial number of the unit when ordering replacement parts.

#### ELECTRICAL:

Capacitors	Temperature Limit Switches
Compressors	Thermostats
Contactors	Time Delay Relays
Pressure Switches	Transformers
Relays	

#### MOTORS:

Blower Motor  
Fan Motor

#### COMPONENTS:

Blower Assembly	Fan Grille
Cabinet Panels	Filter/Driers
Expansion Valves	

