

Troubleshooting

Technical Manual AG220



Change Log

Revision	Date	Proof of Change	Initials
A	2017-07-07	New edition, machine type separate	ZV
B	2022-03-01	Various changes	ZV

Table of Contents

1	Access to Service Menu.....	5
1.1	Overview of the Button Functions in the "Input Test" and "Output Test" Menus	6
2	Service Menu: Input and Output Test.....	7
2.1	OUTPUT TEST	7
2.2	INPUT TEST.....	10
3	Chassis.....	12
3.1	Front View.....	12
3.2	Rear View.....	13
3.3	Left View	14
3.4	Right View.....	15
3.5	View from Above	16
3.6	View from Below/Drain System.....	17
4	Coffee/Water Part.....	18
4.1	Possible Problems	18
4.2	Water Channel to the Pump.....	19
4.3	Detailed View of Pressure Gauge/Bypass	19
4.4	Components	20
4.5	Flow Coffee Channel.....	21
4.6	Tea Channel	22
5	Brewing Unit	23
5.1	Possible Problems	23
5.2	Brewing Unit Overview	25
5.3	View of Brewing Unit from Behind	25
5.4	Detailed View of Brewing Unit Cross Section	26
6	Milk Component.....	27
6.1	Possible Problems	27
6.2	Tea/Milk Boiler	29
6.3	RF Box Refrigerator.....	30
6.4	Milk Pump and Proportional Valve	31
6.5	Cold Milk Channel	32
6.6	Hot Milk Channel.....	33
6.7	Cold Milk Channel View II.....	34
6.8	Hot Milk Channel View II	35
6.9	Cold Milk Channel View II.....	36
6.10	Hot Milk Channel View III.....	37
7	Cleaning.....	38
7.1	Possible Errors	38

7.2	Cleaning Channel View I	39
7.3	Cleaning Channel View II	40
8	Electronics	41
8.1	Possible Problems	41
8.2	Electronics Overview	43
8.3	Connector Overview of Control Board (CPU).....	44
8.4	Connector Overview of Power Board (power PCB)	46
8.5	LED Overview of Control Board (CPU).....	48
8.6	LED Overview of Power Board (power PCB)	50
8.7	Display Messages.....	51

1 Access to Service Menu

The input and output tests help when searching for an error source. The functionality of all valves, sensors etc. installed in the coffee machine can be tested.

If the part concerned is not a valve, the status of the selected part can be seen on the display or its function is activated (e.g. the heater).

To call up the input and output test in the service menu, proceed as follows:

- ▶ Remove capsule container.

- ▶ Insert programming key in the rear area of the drawer and turn clockwise.
 - ⇒ Service menu was entered as technician and the water valve was opened. Upon exiting the technician menu, the water inlet valve is closed again.

- ▶ In the service menu, navigate to the menu item "Input test" or "Output test".

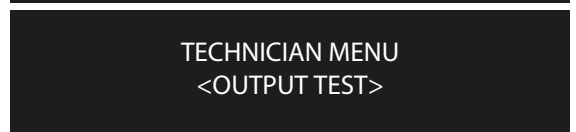
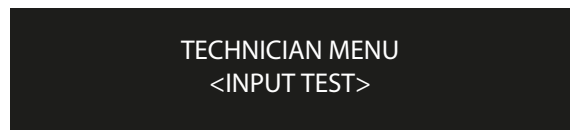
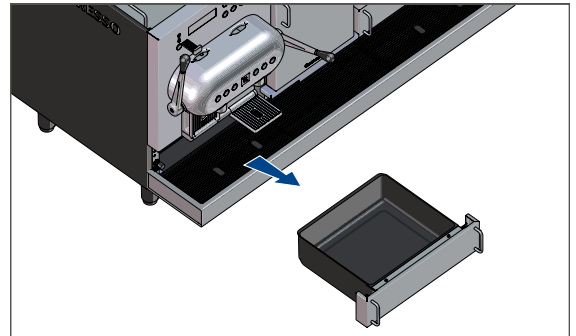

- ▶ Turn programming key anticlockwise and remove.
 - ⇒ Start display ("Ready") appears again.
 - ⇒ Service menu was exited as technician.

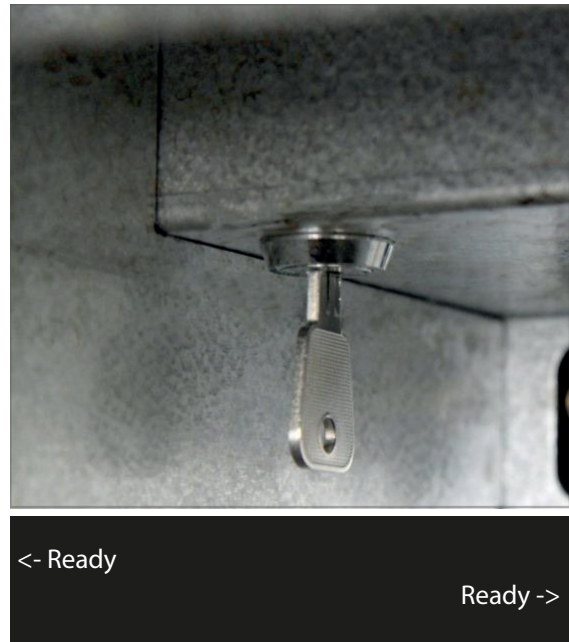

1.1 Overview of the Button Functions in the "Input Test" and "Output Test" Menus

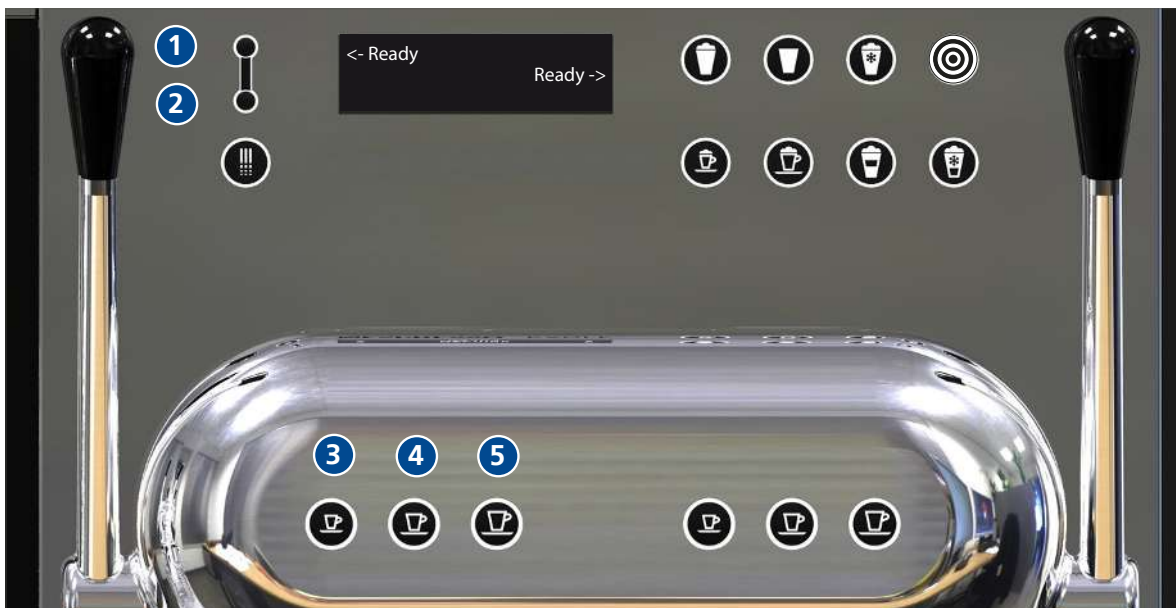

- | | |
|--|--|
| 1 Up (Cleaning button): next menu | 4 Input (Espresso button): non-return valve/
check status/activate function |
| 2 Down (rinse button): Previous menu | 5 Cancel button |
| 3 Standard (Ristretto button): No function | |

2 Service Menu: Input and Output Test

2.1 OUTPUT TEST

In this menu the functionality of all electrical components in the machine can be tested.

- ▶ Press input button.
 - ⇒ Water inlet valve is closed.
 - If a "click" sound can be heard when releasing the button, the valve works.
- ▶ Press input button.
 - ⇒ Brewing chamber valve 1 is opened.
 - If the brewing chamber is closed, a "click" sound should be heard.
- ▶ Press input button.
 - ⇒ Brewing chamber valve 2 is opened.
 - If the brewing chamber is closed, a "click" sound should be heard.
- ▶ Press input button.
 - ⇒ Brewing valve 1 is opened.
 - If the brewing chamber is closed, a "click" sound should be heard.
- ▶ Press input button.
 - ⇒ Brewing valve 2 is opened.
 - If the brewing chamber is closed, a "click" sound should be heard.
- ▶ Press input button.
 - ⇒ Tea valve on the boiler is opened.
 - If a "click" sound can be heard, the valve works.
- ▶ Press input button.
 - ⇒ Venting valve is opened.
 - If a "click" sound can be heard, the valve works.
- ▶ Press input button.
 - ⇒ Milk cleaning valve is opened.
 - If a "click" sound can be heard, the valve works.
- ▶ Press input button.
 - ⇒ Milk rinsing valve is opened.
 - If a "click" sound can be heard, the valve works.

OUTPUT TEST
Water Inlet Valve

OUTPUT TEST
Chamber Release Valve 1

OUTPUT TEST LEFT / RIGHT
Chamber Release Valve 2

OUTPUT TEST
Brew Valve 1

OUTPUT TEST
Brew Valve 2

OUTPUT TEST
Tea Valve

OUTPUT TEST
Venting valve

OUTPUT TEST
Milk Clean Valve

OUTPUT TEST
Milk Rinse Valve

- ▶ Press input button.
 - ⇒ Cold milk valve is opened.
- If a "click" sound can be heard, the valve works.

OUTPUT TEST
Cold Milk Valve

- ▶ Press input button.
 - ⇒ Milk discharge valve is opened.
- If a "click" sound can be heard, the valve works.

OUTPUT TEST
Milk Outlet Valve

- ▶ Press input button.
- ▶ Milk outlet valve is opened.
- If a "click" sound can be heard, the valve works.

OUTPUT TEST
Milk Drain Valve

- ▶ Press input button.
 - ⇒ Milk air valve is opened.

OUTPUT TEST
Milk Air Valve

- ▶ Press input button.
 - ⇒ Cleaning tablet valve is opened.
- If a "click" sound can be heard, the valve works.

OUTPUT TEST
Cleaning Tablet Valve

- ▶ Press and hold down the input button to test the water pump.
 - ⇒ The LED "LD2" illuminates on the Power PCB.

OUTPUT TEST
Water Pump

- ▶ Press and hold down the input button to test the milk pump.
 - ⇒ Fresh water runs through the pump/milk outlet.
- ▶ Start internal rinsing sequence by briefly pressing the input button (5 min).

OUTPUT TEST
Milk Pump

- ▶ Press and hold down the input button to test the fan in the refrigerator.

OUTPUT TEST
Refrigerator fan

- Displays the current temperature of coffee boiler 1.
- ▶ Press input button.
 - ⇒ Boiler heater is switched on.
 - ⇒ The LED "LD5" illuminates on the Power PCB.
- ATTENTION: The controller is not active, the boiler could overheat!
- Displays the current temperature of coffee boiler 2.
- ▶ Press input button.
 - ⇒ Boiler heater is switched on.
 - ⇒ The LED "LD6" illuminates on the Power PCB.

OUTPUT TEST
Coffee boiler 1 = xx.x °C

OUTPUT TEST
Coffee boiler 2 = xx.x °C

- ATTENTION: The controller is not active, the boiler could overheat!
- Displays the current temperature of the tea/milk boiler.
- ▶ Press input button.
 - ⇒ Boiler heater is switched on.
 - ⇒ The LED "LD4" illuminates on the Power PCB.
- ATTENTION: The controller is not active, the boiler could overheat!
- ▶ Press input button to switch on the cup heater.
- ▶ Check cup heater on the Power PCB by means of the LED.
 - ⇒ The LED "LD1" illuminates on the Power PCB.

OUTPUT TEST
Tea/Milk boiler = xx.x °C

OUTPUT TEST
Cup Heater

2.2 INPUT TEST

In this menu the functionality of all inputs (sensors) in the machine can be tested.

- Displays the current status of the grounds drawer.

INPUT TEST
Satzschublade = offen

- Displays the current status of the cleaning key.
- "closed" Cleaning key present and inserted/locked correctly.
- "open": Cleaning key not present.

INPUT TEST
Cleaning key = closed

- Displays whether a cleaning tablet is in the cleaning key.
- "No": No tablet is present in the key (reed switch closed).
- "Yes": Tablet is present in the key (reed switch open).

INPUT TEST
Cleaning tablet = No

- Displays the current status of brewing chamber 1.
- "open": Brewing chamber is opened (microswitch is open).
- "closed": Brewing chamber is closed (microswitch is pressed).

INPUT TEST
Brew Chamber 1 = open

- Displays the current temperature of coffee boiler 1.
- If a temperature of 3276.8 °C is displayed, either a cable break or short-circuit at the NTC has occurred.

INPUT TEST
NTC Boiler 1 = xx.x °C

- Displays the current temperature of coffee boiler 2.
- If a temperature of 3276.8 °C is displayed, either a cable break or short-circuit at the NTC has occurred.

INPUT TEST
NTC Boiler 2 = xx.x °C

- Displays the current temperature of the tea/milk boiler.
- If a temperature of 3276.8 °C is displayed, either a cable break or short-circuit at the NTC has occurred.

INPUT TEST
NTC Boiler 3 = xx.x °C

- Displays the current temperature inside the refrigerator.
- If a temperature of 3276.8 °C is displayed, either a cable break or short-circuit at the NTC has occurred.

INPUT TEST
NTC Refrigerator = x.x °C

- Displays the impulses of flowmeter 1.

- ▶ Press and hold down the input button to test the flowmeter.

INPUT TEST
Flowmeter 1 = x ticks

- ⇒ The number of ticks is displayed (brewing chamber must be closed).
- Displays the current milk temperature in the refrigerator.
- If the temperature is above 12 °C, the preparation of milk products is blocked.
- If a temperature of 3276.8 °C is displayed, either a cable break or short-circuit at the NTC has occurred.
- Displays the status of the upper milk level sensor.
- "Off": "Milk level low" not reached (continuity exists), there is still sufficient milk in the container.
- "On": "Milk level low" reached, milk level is below the sensor (no continuity), milk almost empty.
- Displays the status of the lower milk level sensor.
- "Off": "there is still milk in the container (continuity exists).
- "On": Milk level is below the sensor (no continuity), there is no more milk left.
- Displays the current status of the energy standby button.
- ▶ Press energy standby button.
 - ⇒ Display changes to "On".
- "Off": Button is not pressed, standby mode is not activated.
- "On": Button is pressed, standby mode is activated.

INPUT TEST
Milk temperature = x.x °C

INPUT TEST
Milk Level Low = Off

INPUT TEST
Milk Container Empty = Off

INPUT TEST
Energy Save Button = Off

3 Chassis

3.1 Front View

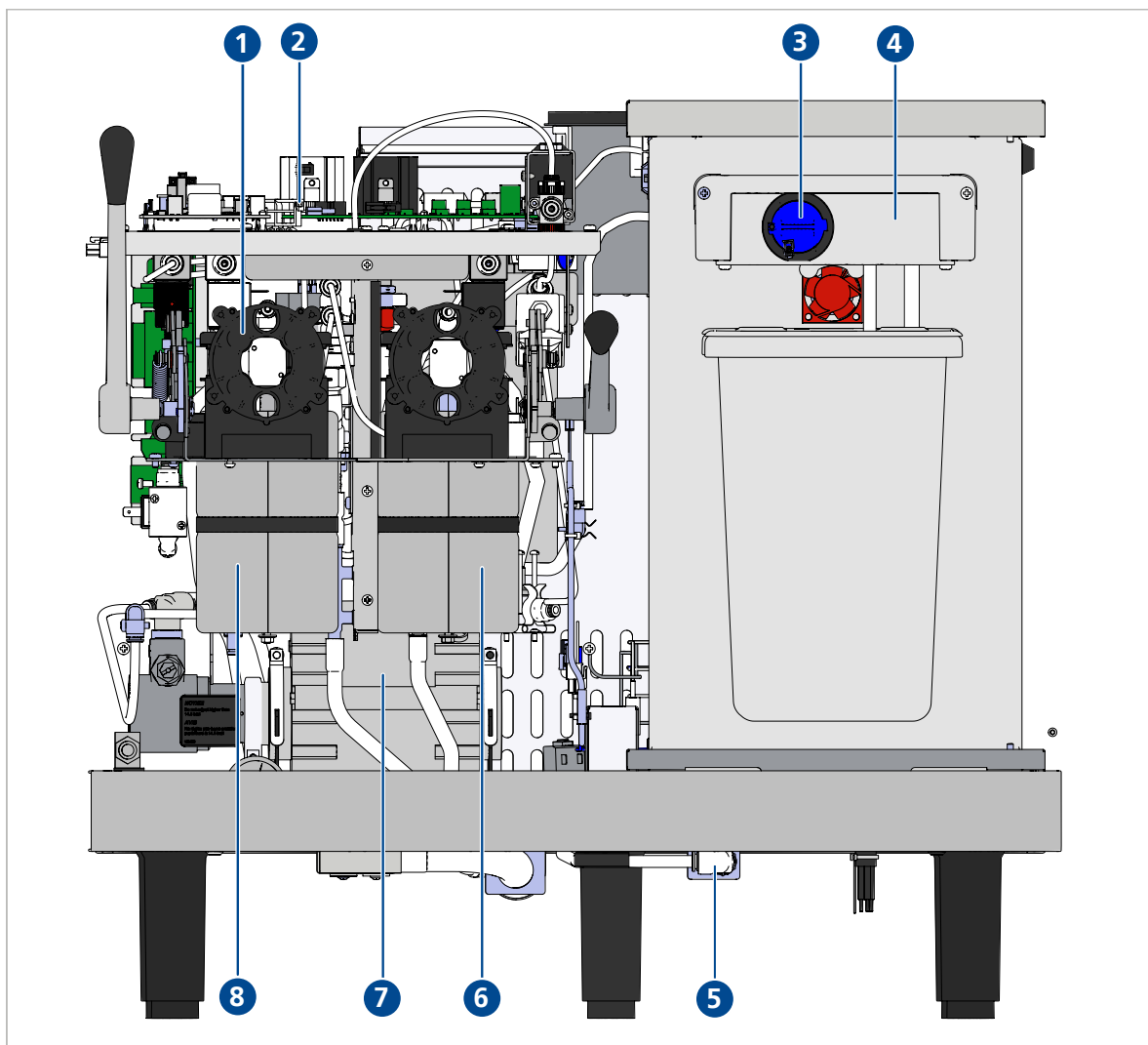

- 1 Brewing Unit
- 2 CPU/power PCB
- 3 Milk cleaning key
- 4 RF-Box

- 5 Water inlet
- 6 Coffee boiler 2
- 7 Water pump unit
- 8 Coffee boiler 1

3.2 Rear View

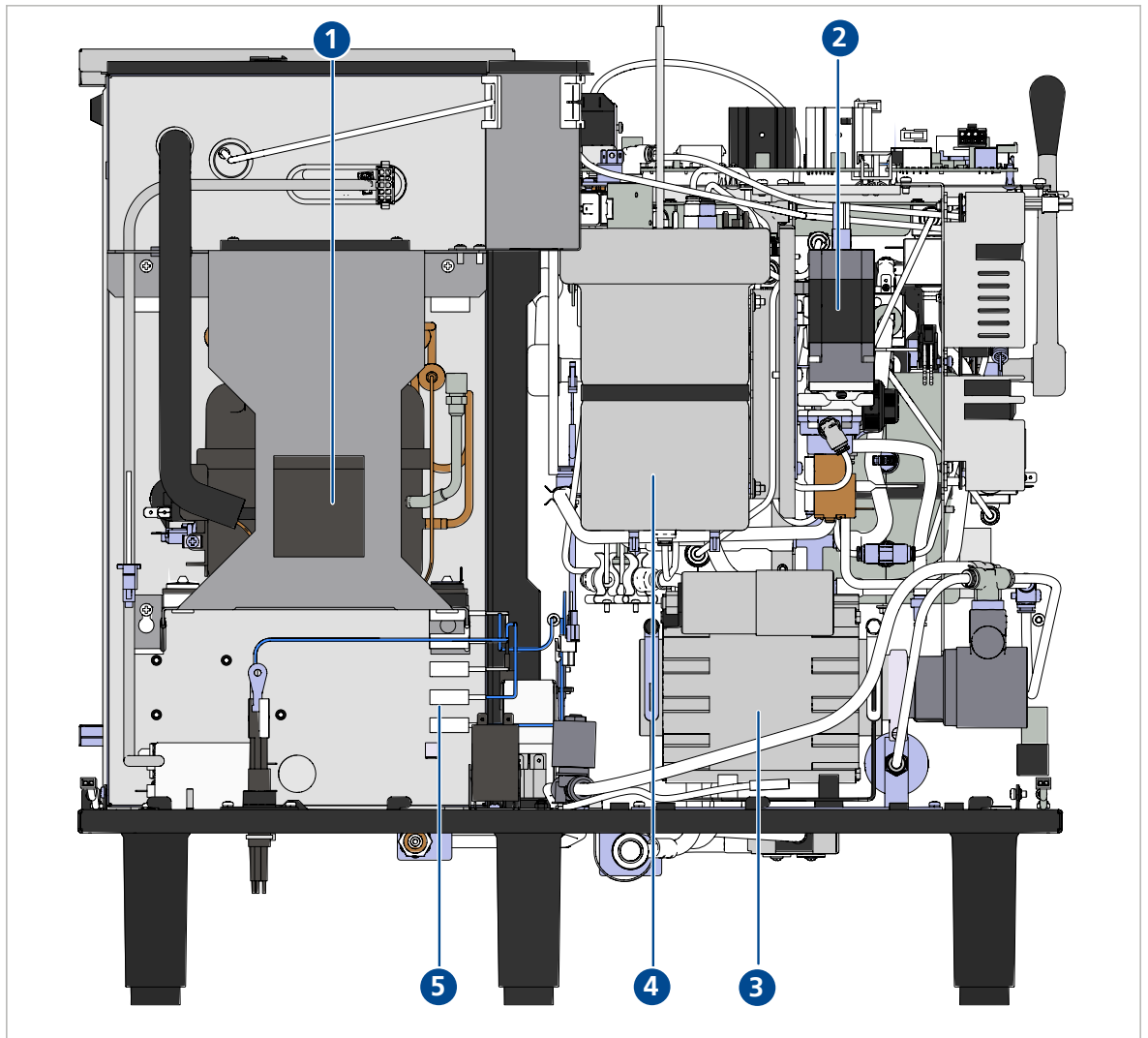

1 Refrigerator compressor

2 Milk pump unit

3 Water pump unit

4 Tea/Milk Boiler

5 Power supply terminals

3.3 Left View

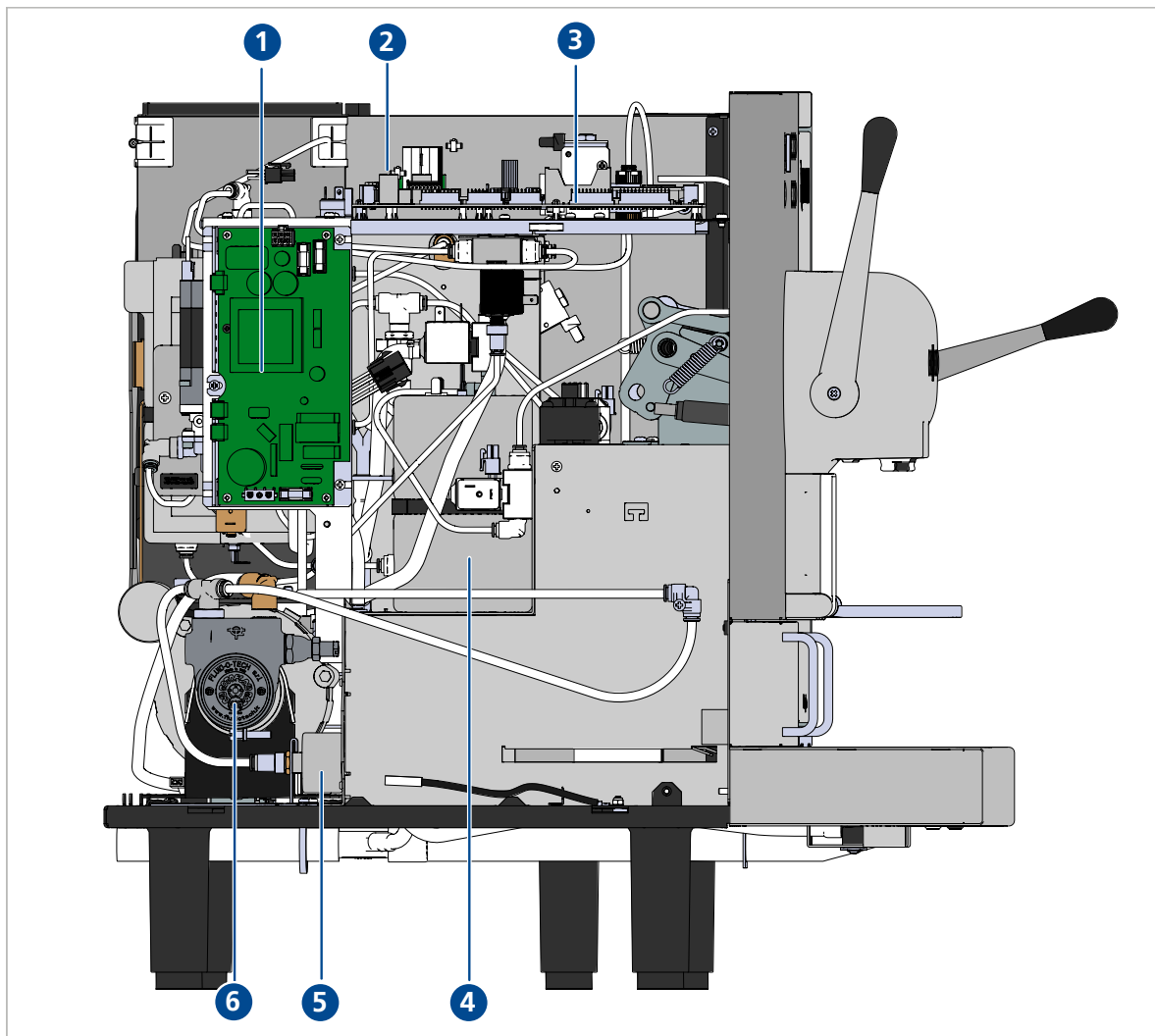

1 Switching power supply

2 Power PCB

3 CPU

4 Coffee boiler

5 Pressure gauge

6 Water pump unit

3.4 Right View

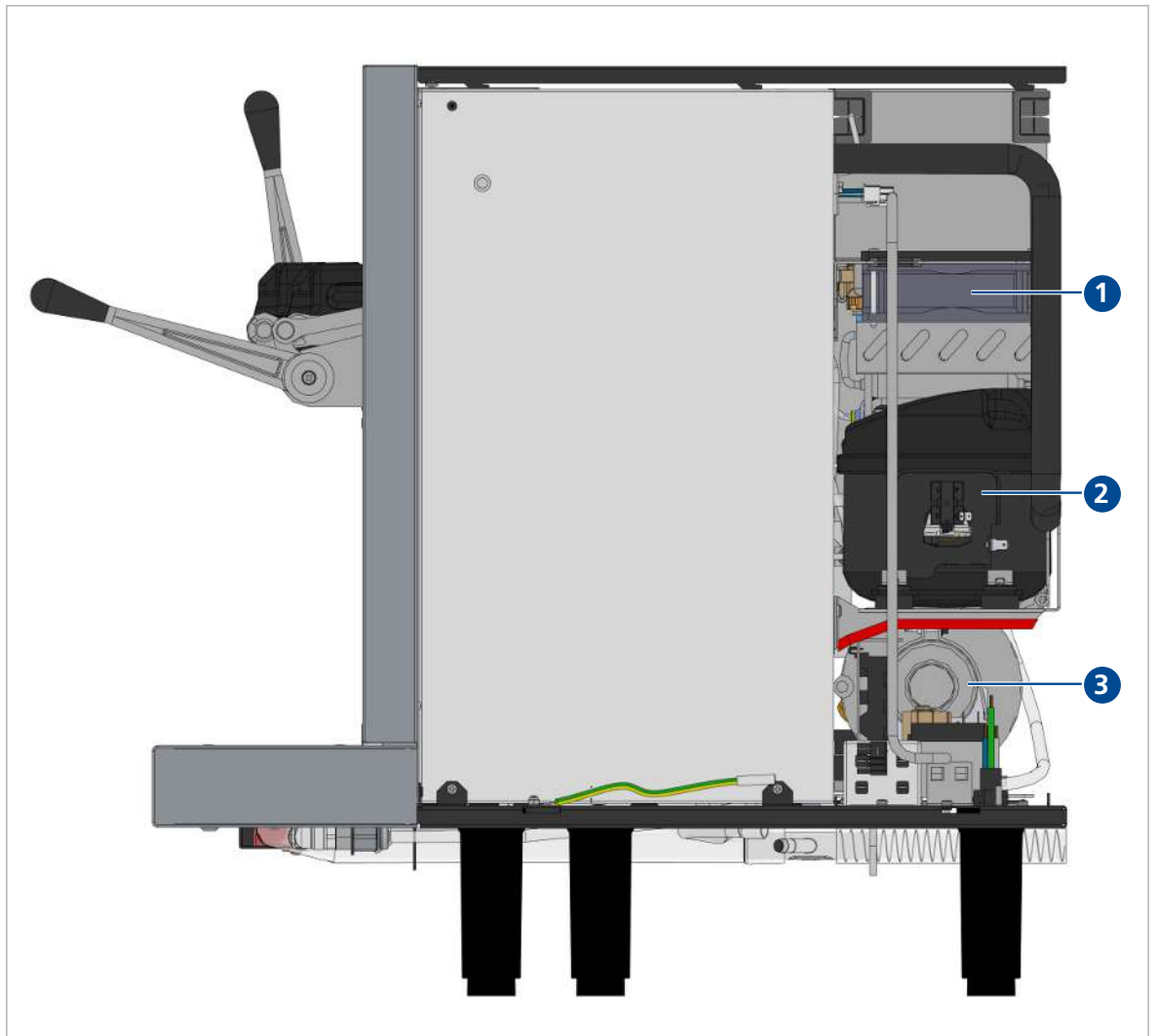

1 Compressor fan

3 Water pump unit

2 Refrigerator compressor

3.5 View from Above

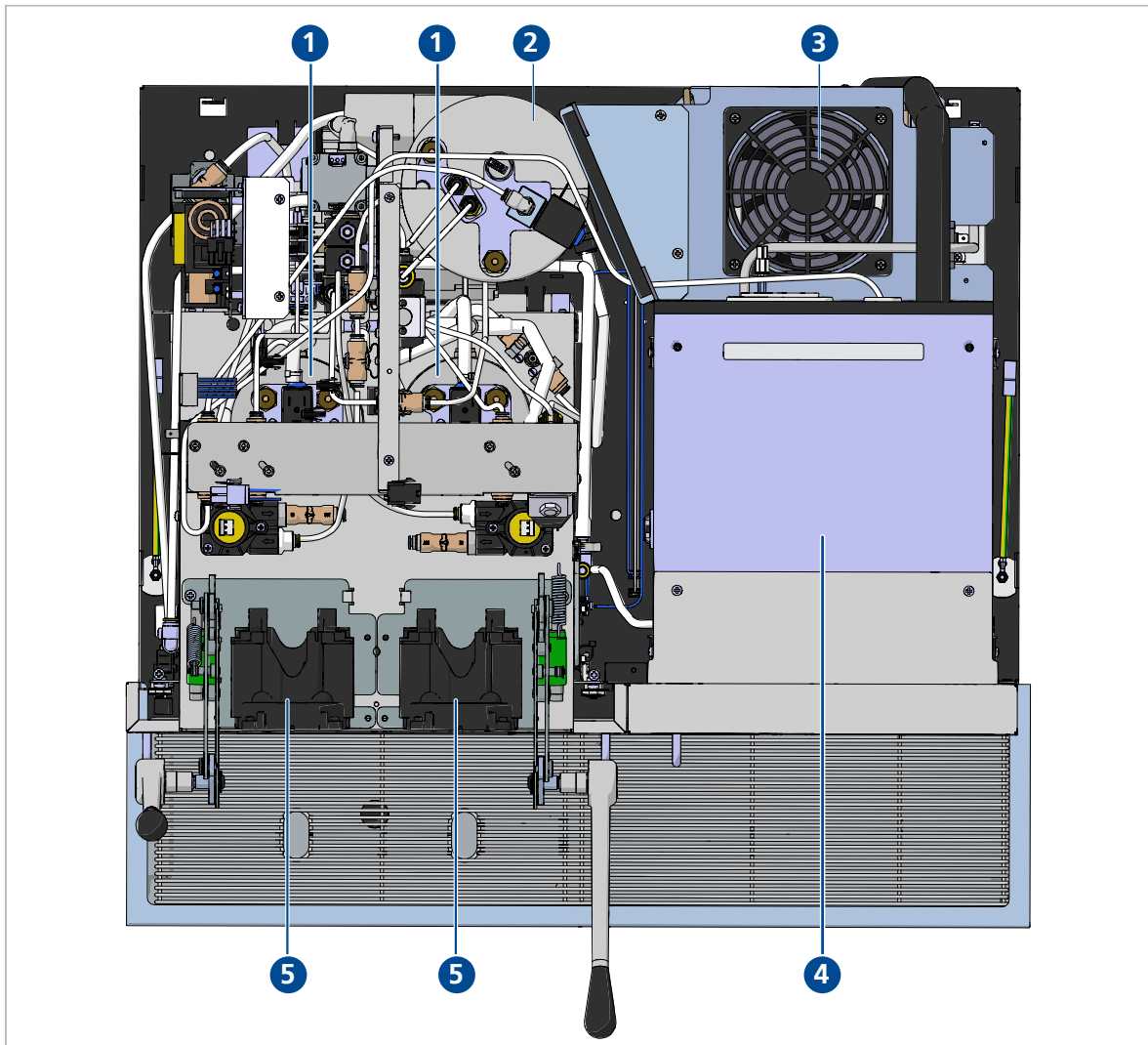

1 Coffee boiler

2 Tea/Milk Boiler

3 Compressor fan

4 Refrigerator

5 Brewing Unit

3.6 View from Below/Drain System

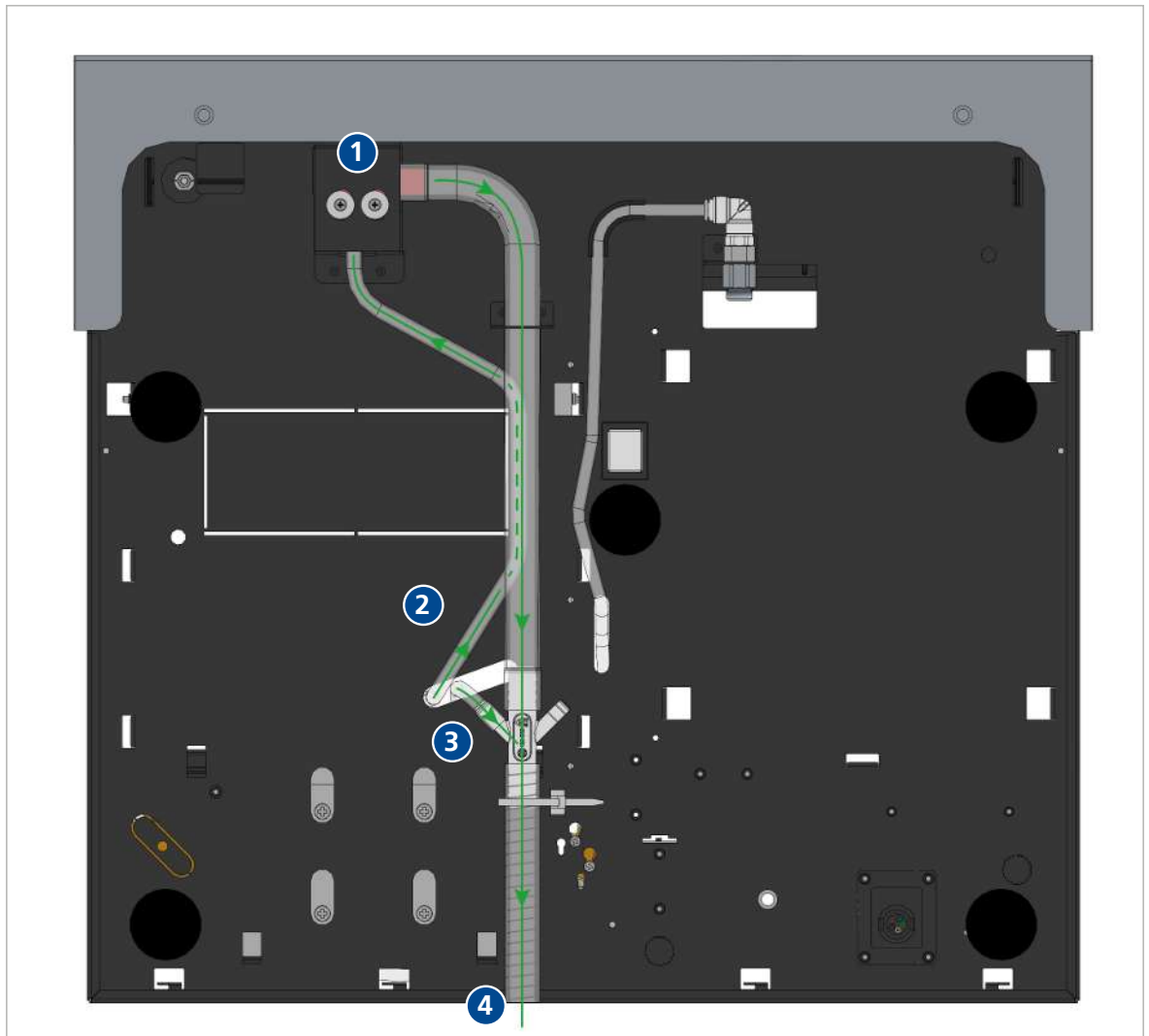

1 Drip tray outlet

2 Milk outlet

3 Outlet of overpressure valves

4 Into the drain

4 Coffee/Water Part

4.1 Possible Problems

Messages	Possible Cause	Solution
No product/display message "Flowmeter # error"	<ul style="list-style-type: none"> • Hoses of the water circuit or brewing unit not connected correctly. • Flowmeter plug oxidised. • Microswitch inserted in reverse on the brewing unit. • No water supply. • Filter in the water inlet/flowmeter blocked. • Water flow too low or interrupted. • Electrical circuit interrupted. 	<ul style="list-style-type: none"> ▶ Connect hoses of the water circuit or brewing unit correctly. ▶ Check everything and replace if necessary. ▶ Connect microswitch correctly. ▶ Check water inlet valve. ▶ Check filter. ▶ Check water flow to brewing group. ▶ Check electrical circuit until the flowmeter.
Display message "Error: NTC # short-circuit"	<ul style="list-style-type: none"> • # = 1: Coffee boiler 1. • # = 2: Coffee boiler 2. • # = 3: Tea/milk boiler. • NTC short-circuit. • Short-circuit in the NTC circuit. 	<ul style="list-style-type: none"> ▶ Check NTC of the corresponding coffee boiler. Measured value: 10 kΩ at 25 °C. ▶ Check electrical circuit of the NTC.
Display message "Error: NTC # breakage"	<ul style="list-style-type: none"> • # = 1: Coffee boiler 1. • # = 2: Coffee boiler 2. • # = 3: Tea/milk boiler. • Interruption of the NTC from boiler. • Interruption in the NTC circuit. 	<ul style="list-style-type: none"> ▶ Check brewing unit for water leakage. ▶ Hoses from the 3rd channel "outlet" not connected to module; cracks in the hose; check all hose connections. ▶ When after cold start rinsing: Clean coffee outlet.
Water under the machine	<ul style="list-style-type: none"> • Leak. 	<ul style="list-style-type: none"> ▶ Check brewing unit for water leakage. ▶ Hoses from the 3rd channel "outlet" not connected to module; cracks in the hose; check all hose connections. ▶ When after cold start rinsing: Clean coffee outlet.
Long heating up time/Display message "Heating up"/ "Please wait"	<ul style="list-style-type: none"> • The corresponding boiler has not yet reached the operating temperature. • Defective NTC on the boiler. • Defective component in the corresponding heating circuit. • Boiler has limescale. 	<ul style="list-style-type: none"> ▶ Wait until operating temperature is reached ("Ready"). ▶ In the "Input test" service menu check the NTC. ▶ Check complete heating circuit: CPU/Powerprint/Triac; temperature fuses; heating element.

Messages	Possible Cause	Solution
		▶ Check boiler.

4.2 Water Channel to the Pump

Water channel until pump and detailed view of water connection with non-return valve:

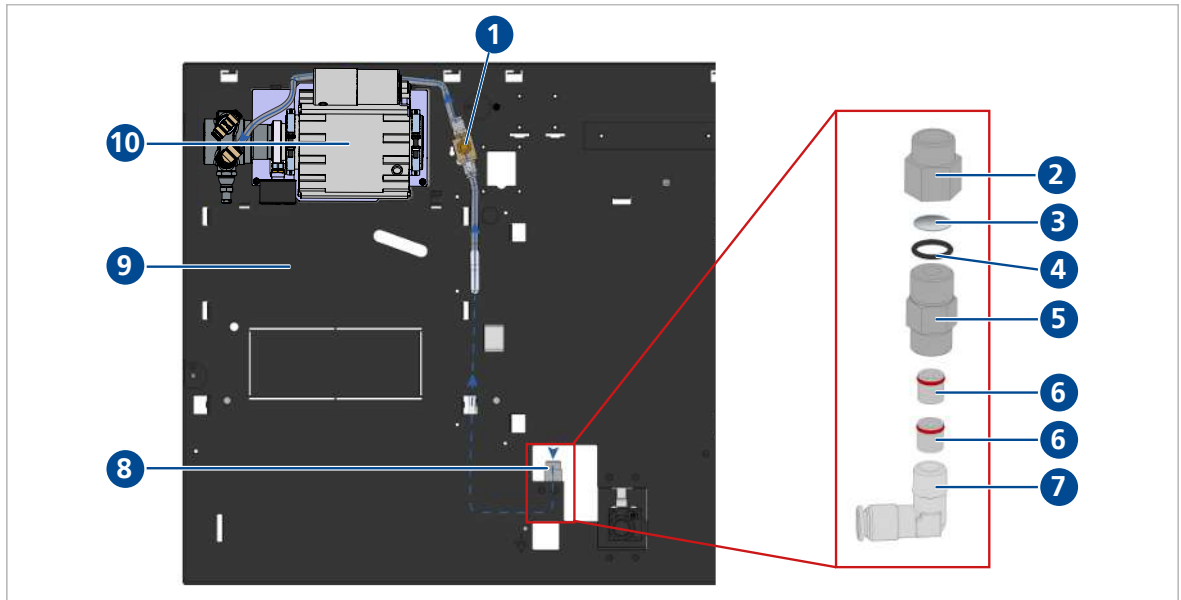

1	Water inlet valve	2	Reducing nipple
3	Filter	4	O-ring 12x2
5	Reduction MW	6	Check valves
7	Elbow fitting	8	Water connection
9	Bottom plate	10	Water pump unit

4.3 Detailed View of Pressure Gauge/Bypass

The water inlet pressure must be between 2-4 bar when the machine is switched on.

During preparation of a coffee product and a correspondingly activated water pump, the brewing pressure must increase to 14.5 bar.

To check the pressure during preparation of the product: Remove the capsule container on the left module and dispense a product on the right module.

If the brewing pressure does not match the required values, the bypass can be adjusted as follows:

- ▶ Loosen hexagon nut to adjust bypass.
- ▶ Adjust bypass:
 - clockwise: increase pressure
 - anticlockwise clockwise: decrease pressure
- ▶ Tighten hexagon nut again.

4.4 Components

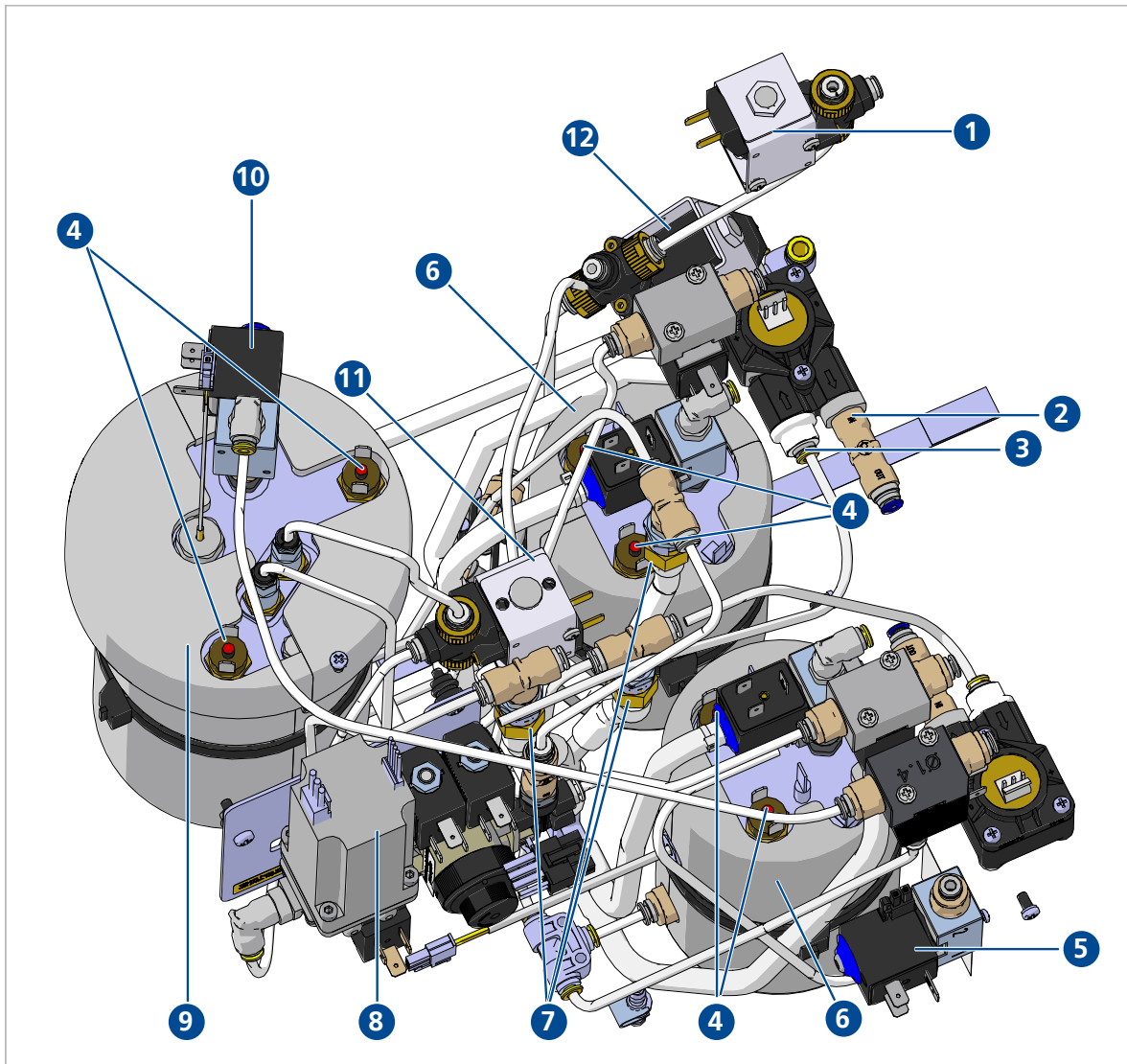

- | | |
|----------------------------|---|
| 1 Venting valve | 7 Overpressure valve (16.5 bar \pm 1 bar) |
| 2 Output flowmeter | 8 Milk pump |
| 3 Input flowmeter | 9 Tea/Milk Boiler |
| 4 Overheating fuse (125°C) | 10 Tea valve |
| 5 Tea Valve 2 | 11 Cold milk valve |
| 6 Coffee boiler | 12 Milk outlet valve |

4.5 Flow Coffee Channel

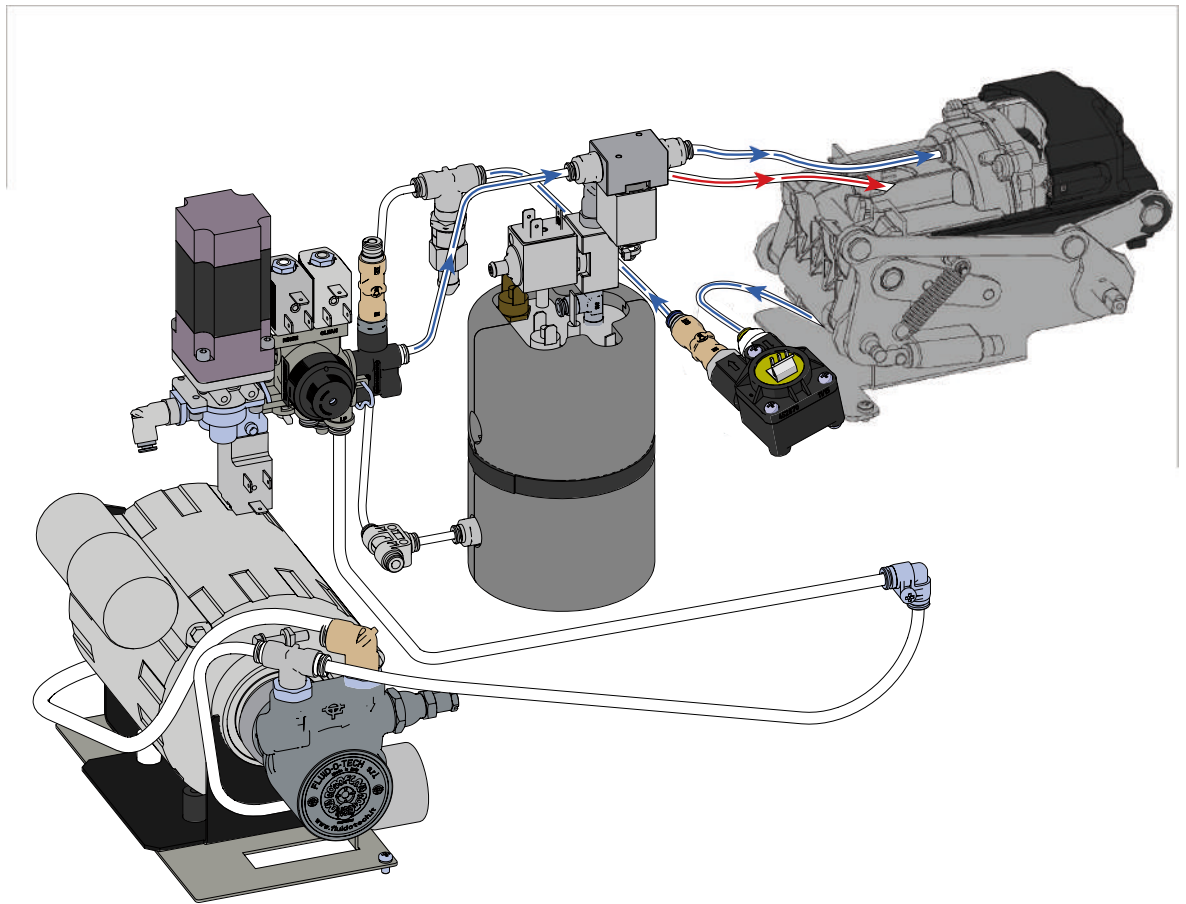

- | | |
|-------------------------|----------------------|
| 1 Water inlet | 6 Flowmeter |
| 2 Water pump | 7 Overpressure valve |
| 3 Cleaning block | 8 Coffee boiler |
| 4 Brewing chamber valve | 9 Brewing valve |
| 5 Brewing Unit | 10 Coffee outlet |

4.6 Tea Channel

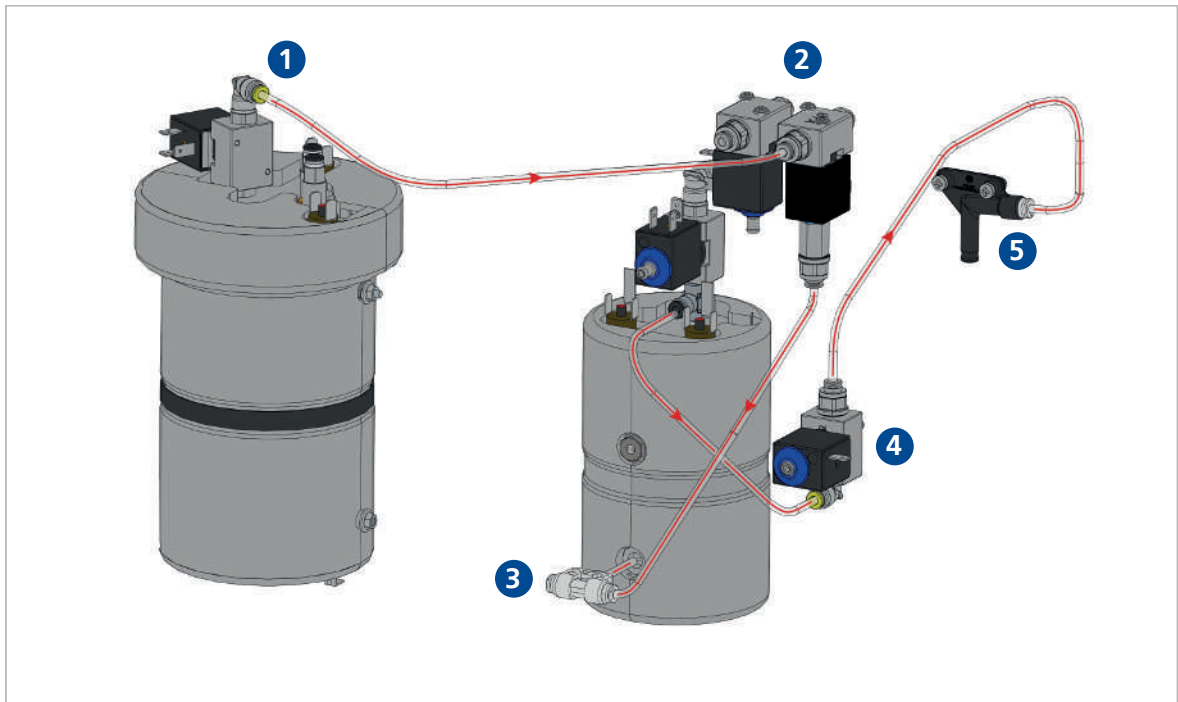

1 Tea valve

2 Cleaning tablet valve

3 Coffee boiler

4 Tea Valve 2

5 Tea outlet

5 Brewing Unit

5.1 Possible Problems

Messages	Possible Cause	Solution
Capsule does not fall through/ cannot be inserted	<ul style="list-style-type: none"> • Lever not in starting position. • Capsule is blocking the channel. 	<ul style="list-style-type: none"> ▶ Try again. ▶ Check parts, replace.
Display message "Preparation too short"	<ul style="list-style-type: none"> • Flowmeter detects too much water flow during a specific time. • No capsule in the brewing unit. • Water leak in the brewing circuit. • Brewing valve or brewing chamber valves leaky. • Non-return valve on the flowmeter defective. • Brewing unit is leaky. 	<ul style="list-style-type: none"> ▶ Insert capsule correctly. ▶ Check water circuit (flowmeter until brewing chamber). ▶ Check brewing valves/brewing chamber valves and replace if necessary. ▶ Check non-return valve on the flowmeter and replace if necessary. ▶ Check brewing unit.
Display message "Preparation too long"	<ul style="list-style-type: none"> • Flowmeter detects too little water flow during a specific time. • Brewing pressure too low. • Water inflow interrupted. • Water pump is not running. • Coffee capsule defective. 	<ul style="list-style-type: none"> ▶ Check the brewing pressure using pressure gauge. It must be 14.5 bar ([see Detailed View of Pressure Gauge/ Bypass ▶ 19]). ▶ Check water pump. ▶ Use other coffee capsules.
Display message "Flowmeter x error"	<ul style="list-style-type: none"> • Water inflow interrupted. 	<ul style="list-style-type: none"> ▶ Check flowmeter
Display message "Open the lever" or "Close the lever"	<ul style="list-style-type: none"> • Brewing chamber closed/open. • Microswitch defective. • Microswitch not inserted or interchanged with another brewing chamber. 	<ul style="list-style-type: none"> ▶ Open/close lever. ▶ Check microswitch in the input test (brewing chamber) and replace if necessary. ▶ Check cabling and insert correctly.
Display message "Wait until pressure is relieved"	<ul style="list-style-type: none"> • Brewing chamber was opened during product preparation. • Brewing chamber locking plate too weak. 	<ul style="list-style-type: none"> ▶ First press lever after product preparation. Wait until message disappears. ▶ Adjust locking plate.
Lever broken/not in original position	<ul style="list-style-type: none"> • Too much force applied. 	<ul style="list-style-type: none"> ▶ Replace lever.
Coffee outlet squirts	<ul style="list-style-type: none"> • Coffee outlet dirty • Coffee outlet broken/lost. 	<ul style="list-style-type: none"> ▶ Clean coffee outlet ▶ Fit new coffee outlet.
No coffee at the touch of a button	<ul style="list-style-type: none"> • Keyboard print defective. • Lever not closed. • Microswitch no contact. 	<ul style="list-style-type: none"> ▶ Replace keyboard print. ▶ Check lever and close.

Messages	Possible Cause	Solution
		<ul style="list-style-type: none"> ▶ Check microswitch and replace if necessary.
Drip grid for small cups does not hold in top position	<ul style="list-style-type: none"> • Magnet fallen out. 	<ul style="list-style-type: none"> ▶ Stick on magnet again/replace.
No coffee	<ul style="list-style-type: none"> • Capsule does not break: • Brewing pressure too low. • Brewing valve/brewing chamber valve defective or leaky. • Overpressure valve defective. 	<ul style="list-style-type: none"> ▶ Check the brewing pressure using pressure gauge. It must be 14.5 bar ([see Detailed View of Pressure Gauge/ Bypass ▶ 19]). ▶ Check brewing valve/brewing chamber valve and replace if necessary. ▶ Replace overpressure valve.
Much water in the capsule container	<ul style="list-style-type: none"> • Leaking water cold: • Leaky brewing unit. • Hose connection not tight. • Piston seal not tight. • Leaking water warm: • Seal of ejector pin: Hose connection not tight. • Capsule seal not tight or fallen off. • Brewing valves leaky. 	<ul style="list-style-type: none"> ▶ Check brewing unit and replace if necessary. ▶ Check brewing unit/brewing valve and replace if necessary. ▶ Check anchor.
Display message "BU Service required!"	<ul style="list-style-type: none"> • The number of capsules of the brewing unit defined in the service menu "BU Max. products" was not reached. 	<ul style="list-style-type: none"> ▶ Replace brewing unit (arrow direction of the message indicates which BU must be replaced). ▶ Reset the corresponding counter "BU left/right reset" in the service menu under "Statistics".

5.2 Brewing Unit Overview

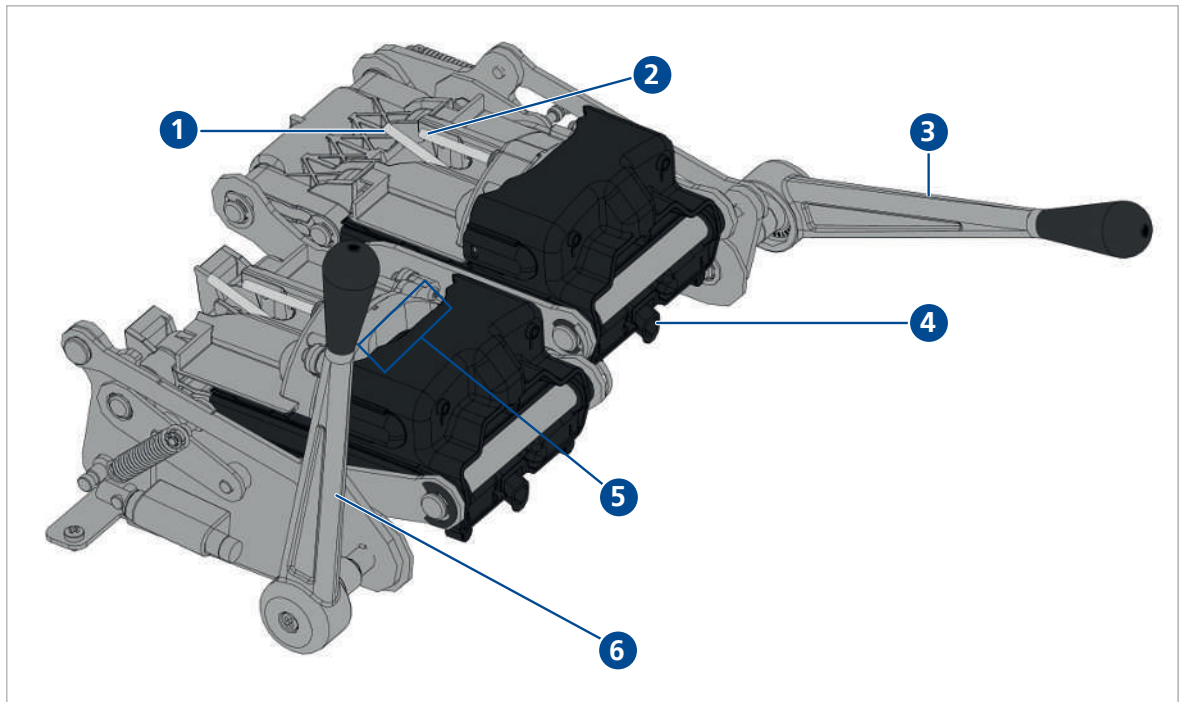

- | | |
|---|---------------------------------------|
| 1 Hot water inlet | 4 Coffee outlet |
| 2 Cold water inlet | 5 Position of the capsule slot |
| 3 Lever position of brewing unit closed | 6 Lever position of brewing unit open |

5.3 View of Brewing Unit from Behind

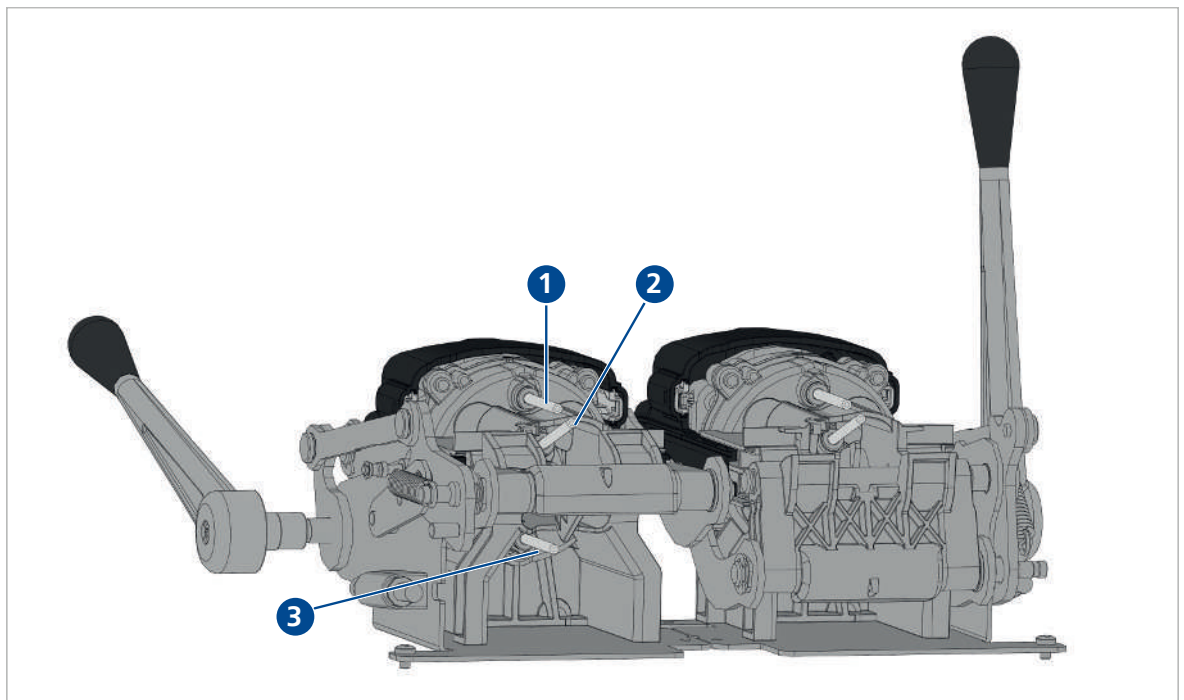

- | | |
|--------------------|---------------------|
| 1 Cold water inlet | 3 Cold water outlet |
| 2 Hot water inlet | |

5.4 Detailed View of Brewing Unit Cross Section

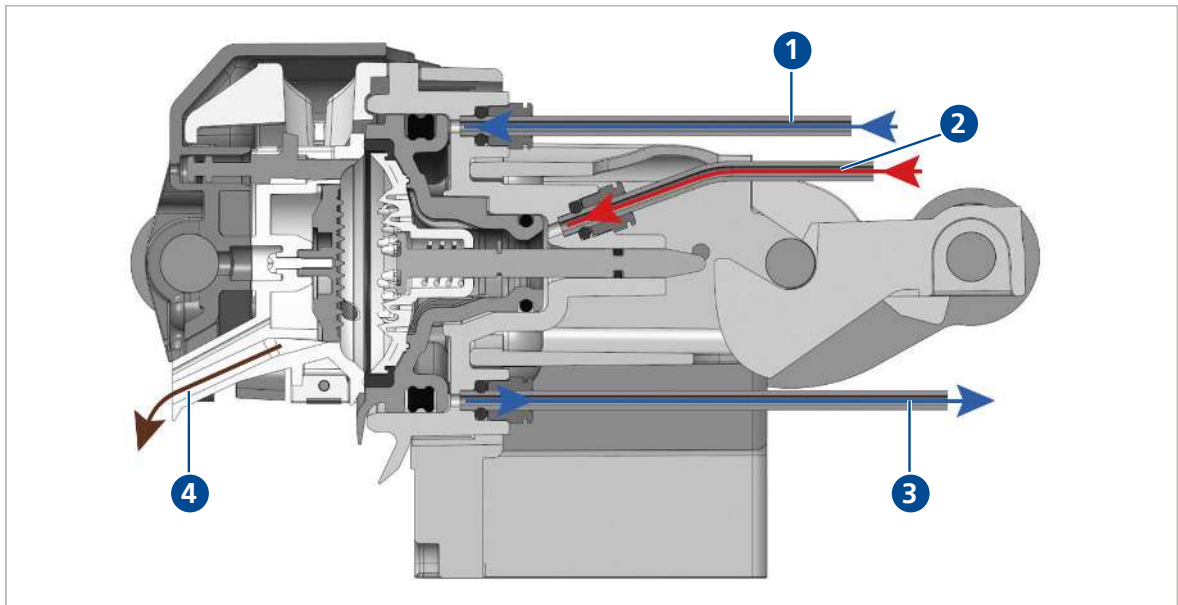

1 Cold water inlet

3 Cold water outlet

2 Hot water inlet

4 Coffee outlet

6 Milk Component

6.1 Possible Problems

Messages	Possible Cause	Solution
None or poor milk foam	<ul style="list-style-type: none"> • Warm milk used. • Impurities in the milk system. • Lip valve of the proportional valve is stuck. • Nozzle at the milk pump outlet clogged (also causes a reduced quantity of milk). • Milk air valve defective. • Watery milk. • Air supply set incorrectly in the service menu. 	<ul style="list-style-type: none"> ▶ Use cold milk (<5°C). ▶ Check complete milk system, including the milk outlet and milk outlet valve. ▶ Remove and clean lip valve, replace if necessary. ▶ Clean nozzle. ▶ Check valve and replace if necessary. ▶ See problem "watery milk in the container". ▶ Adjust the air supply for "Hot foam" and "Cold foam" in the service menu under "Milk settings".
Refrigerator too cold/warm	<ul style="list-style-type: none"> • Wrong temperature set. • Door seal not tight. • NTC of the refrigerator is defective. 	<ul style="list-style-type: none"> ▶ In the service menu adjust the "refrigerator temperature" under "Milk settings". ▶ Check door seal. ▶ Check NTC of the refrigerator and replace if necessary. ▶ Measured value: 10 kΩ at 25 °C.
"Milk temperature high"	<ul style="list-style-type: none"> • The temperature of the milk is slightly too high (between 6 and 12 °C). 	<ul style="list-style-type: none"> ▶ The milk temperature is slightly too high but milk products can still be prepared.
Display message "Milk temperature too high Replace with cold milk"	<ul style="list-style-type: none"> • The temperature of the milk in the refrigerator is too high (above 12°C). • Door seal of the refrigerator is not tight. • NTC of the refrigerator is defective. • Refrigerator does not cool. 	<ul style="list-style-type: none"> ▶ Milk products are blocked; check milk temperature, fill milk with max. temp from 5 °C. ▶ Check door seal. ▶ Check NTC of the refrigerator and replace if necessary. Measured value: 10 kΩ at 25 °C. ▶ Check cooling unit (check LED on CPU/compressors).
"Rinsing in progress"	<ul style="list-style-type: none"> • Machine is performing an automatic milk rinse (outlet 2 and 4). 	<ul style="list-style-type: none"> ▶ No product preparation possible, wait until rinsing has ended.

Refrigerator does not cool	<ul style="list-style-type: none"> • Compressor defective. • NTC of the refrigerator is defective. 	<ul style="list-style-type: none"> ▶ Check compressor (compressor first starts 5 minutes after switching on the machine for reasons of safety). ▶ Check NTC of the refrigerator and replace if necessary. Measured value: 10 kΩ at 25 °C.
Watery milk in the container	<ul style="list-style-type: none"> • Milk non-return valve defective. 	<ul style="list-style-type: none"> ▶ Test milk non-return valve: Trigger milk rinsing. Water must not run back into the milk container.
Display message "Milk level low, top up milk"	<ul style="list-style-type: none"> • Milk is almost empty. • Cable break of the Milk Level detector or the Minus detector in the milk suction tube. 	<ul style="list-style-type: none"> ▶ Top up milk. ▶ Check electrical "Milk level" circuit: Voltage between Milk level detector and Minus detector must be at 3.5 VAC.
Display message "Milk container empty. Top up milk"	<ul style="list-style-type: none"> • Milk is empty. • Cable break of the Milk Empty detector or the Minus detector in the milk suction tube. 	<ul style="list-style-type: none"> ▶ Top up milk. ▶ Check level temperature sensor in the input test [INPUT TEST ▶ 10] ▶ Check electrical "Milk empty" circuit: Voltage between Milk empty detector and Minus detector must be at 3.5 VAC.
Display message "Error: NTC R short-circuit"	<ul style="list-style-type: none"> • Short-circuit in the NTC circuit. • Short-circuit in the electrical circuit of the refrigerator. 	<ul style="list-style-type: none"> ▶ Check NTC of the refrigerator and replace if necessary. Measured value: 10 kΩ at 25 °C. ▶ Check electrical circuit of the refrigerator.
Display message "Error: NTC R breakage"	<ul style="list-style-type: none"> • Interruption of the NTC circuit. • Interruption in the electrical circuit of the refrigerator. 	<ul style="list-style-type: none"> ▶ Check NTC of the refrigerator and replace if necessary. Measured value: 10 kΩ at 25 °C. ▶ Check electrical circuit of the refrigerator.
Display message "Milk pump error"	<ul style="list-style-type: none"> • Milk pump does not reach the required speed. • Electrical circuit of the milk pump interrupted or short-circuit occurred. • Milk pump is blocked. 	<ul style="list-style-type: none"> ▶ Check milk pump in the service menu "Output test" and replace if necessary. ▶ Check electrical circuit. ▶ Check/clean the milk system ▶ Replace milk pump.

6.2 Tea/Milk Boiler

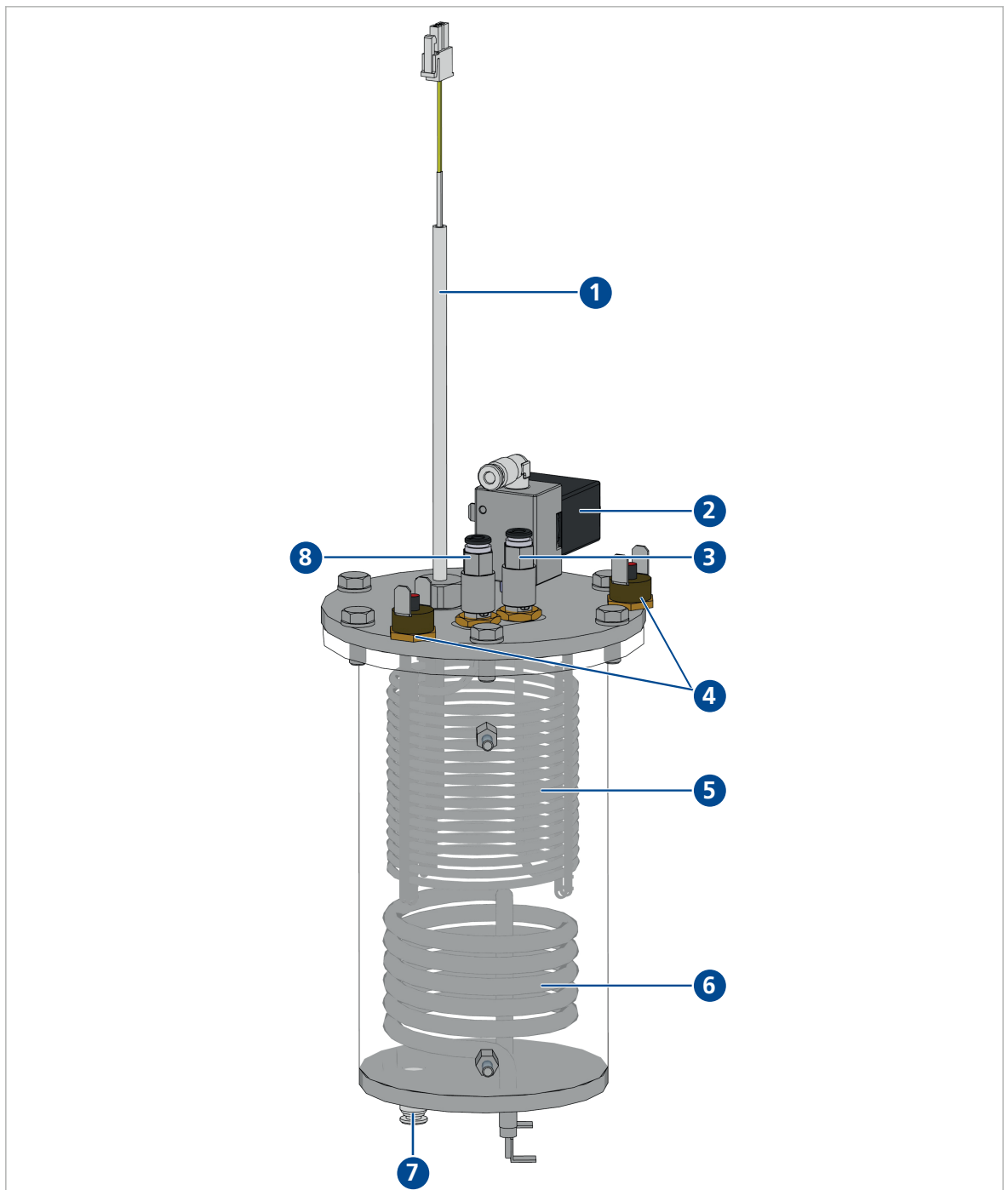

1 NTC

2 Tea valve

3 Coil input

4 Overtemperature fuses

5 Milk heating coil

6 Heater

7 Water inlet

8 Coil output

6.3 RF Box Refrigerator

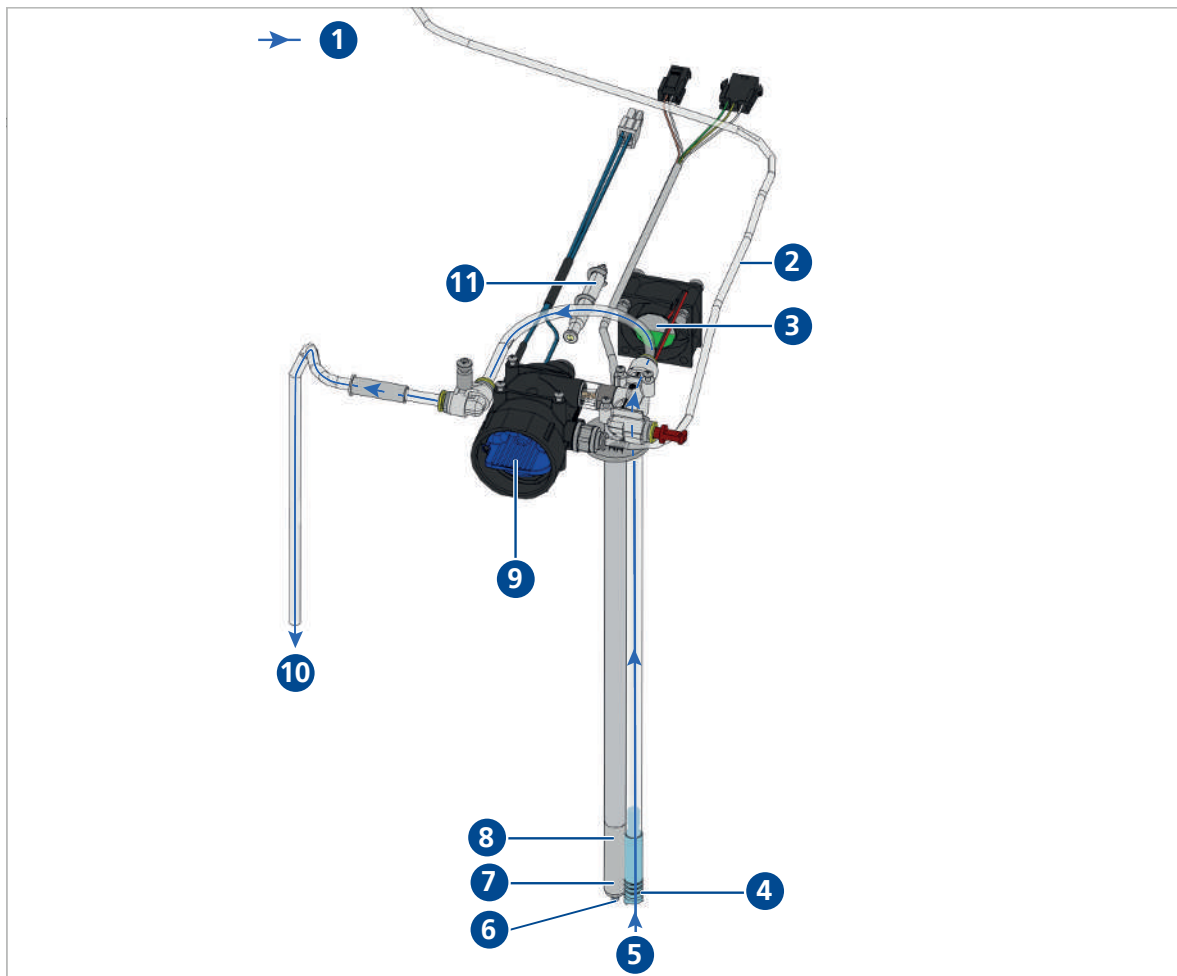

- | | |
|-----------------------------|-----------------------------|
| 1 Cold milk | 7 Sensor "Milk level empty" |
| 2 Water supply cleaning key | 8 Sensor "Milk level low" |
| 3 Fan refrigerator | 9 Milk cleaning key |
| 4 Suction filter | 10 to the module |
| 5 Milk inlet | 11 NTC refrigerator |
| 6 Sensor "milk temperature" | |

6.4 Milk Pump and Proportional Valve

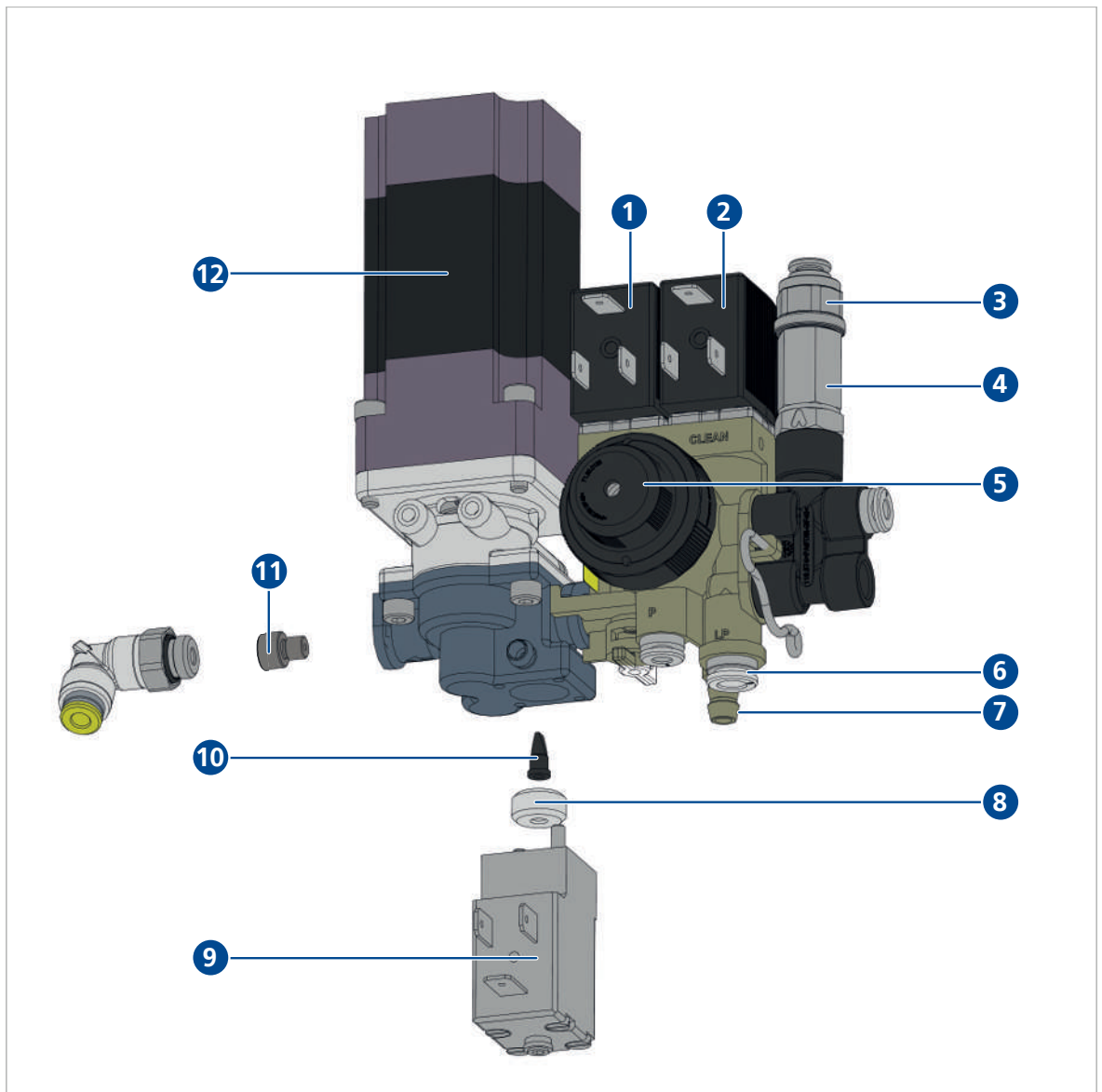

- | | |
|------------------------------------|------------------------------------|
| 1 Milk rinsing valve | 7 Milk inlet |
| 2 Milk cleaning valve | 8 Valve seat |
| 3 Water outlet milk/tea boiler | 9 Proportional valve |
| 4 Non-return valve with tea nozzle | 10 Lip valve of proportional valve |
| 5 Pressure reducing valve | 11 Outlet nozzle |
| 6 Water inlet | 12 DC motor of the milk pump |

6.5 Cold Milk Channel

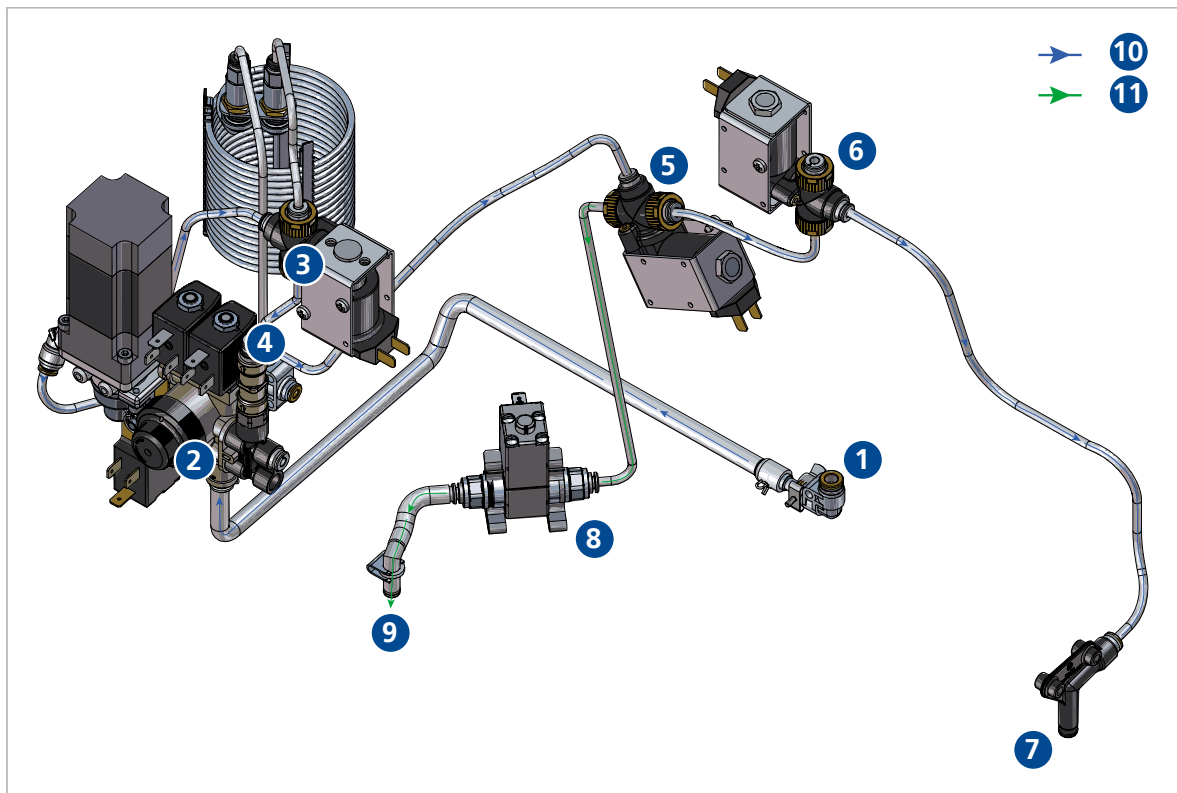

- | | |
|---------------------------------|---------------------|
| 1 Milk supply from refrigerator | 7 Milk outlet |
| 2 Cleaning block milk pump | 8 Milk outlet valve |
| 3 Cold milk valve | 9 Outlet |
| 4 Merging of hot and cold milk | 10 Cold milk |
| 5 Milk outlet valve | 11 Outlet |
| 6 Venting valve | |

6.6 Hot Milk Channel

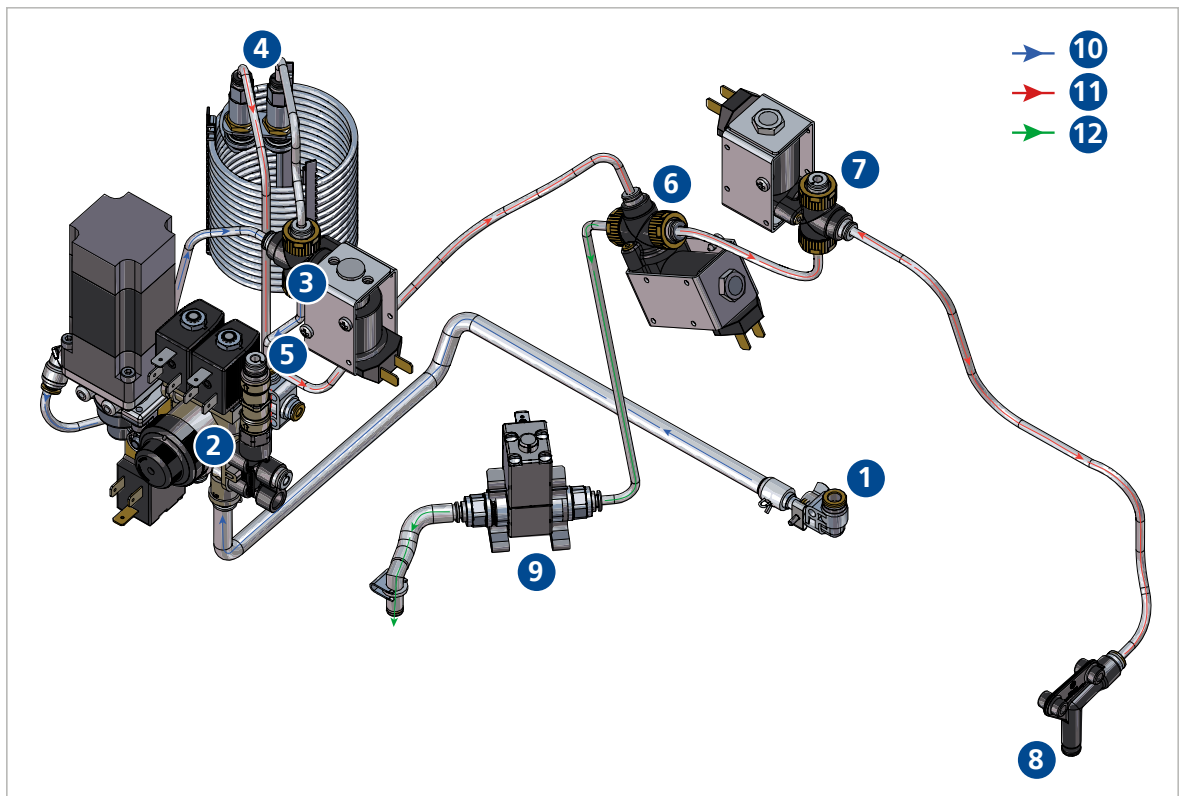

- 1 Milk supply from refrigerator
- 2 Cleaning block milk pump
- 3 Cold milk valve
- 4 Milk heating coil
- 5 Merging of hot and cold milk
- 6 Milk outlet valve

- 7 Venting valve
- 8 Milk outlet
- 9 Milk outlet valve
- 10 Cold milk
- 11 Hot milk
- 12 Outlet

6.7 Cold Milk Channel View II

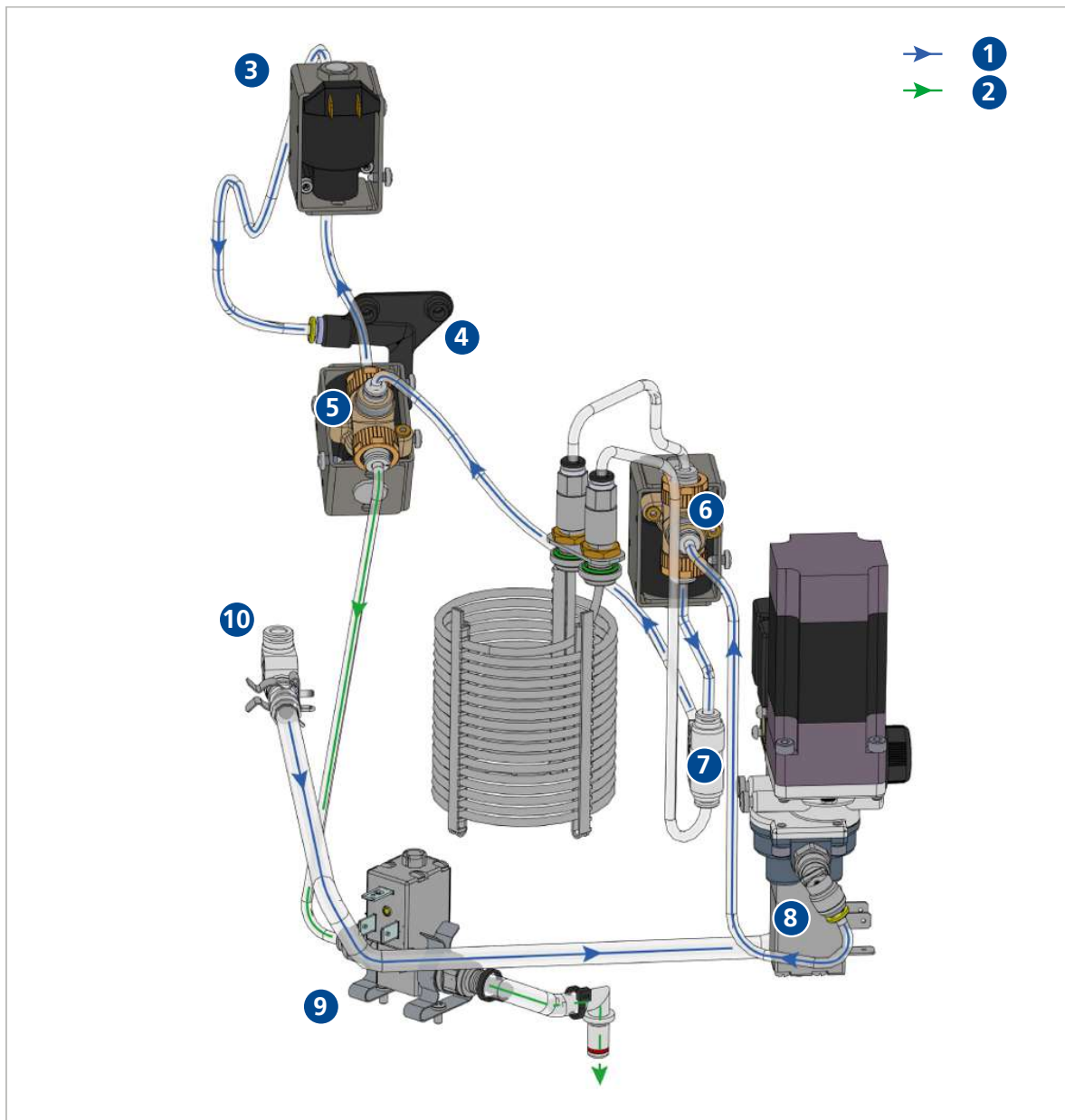

1 Cold milk

2 Outlet

3 Venting valve

4 Milk outlet

5 Milk outlet valve

6 Cold milk valve

7 Plug connection

8 Cleaning block milk pump unit

9 Milk outlet valve

10 Milk supply from refrigerator

6.8 Hot Milk Channel View II

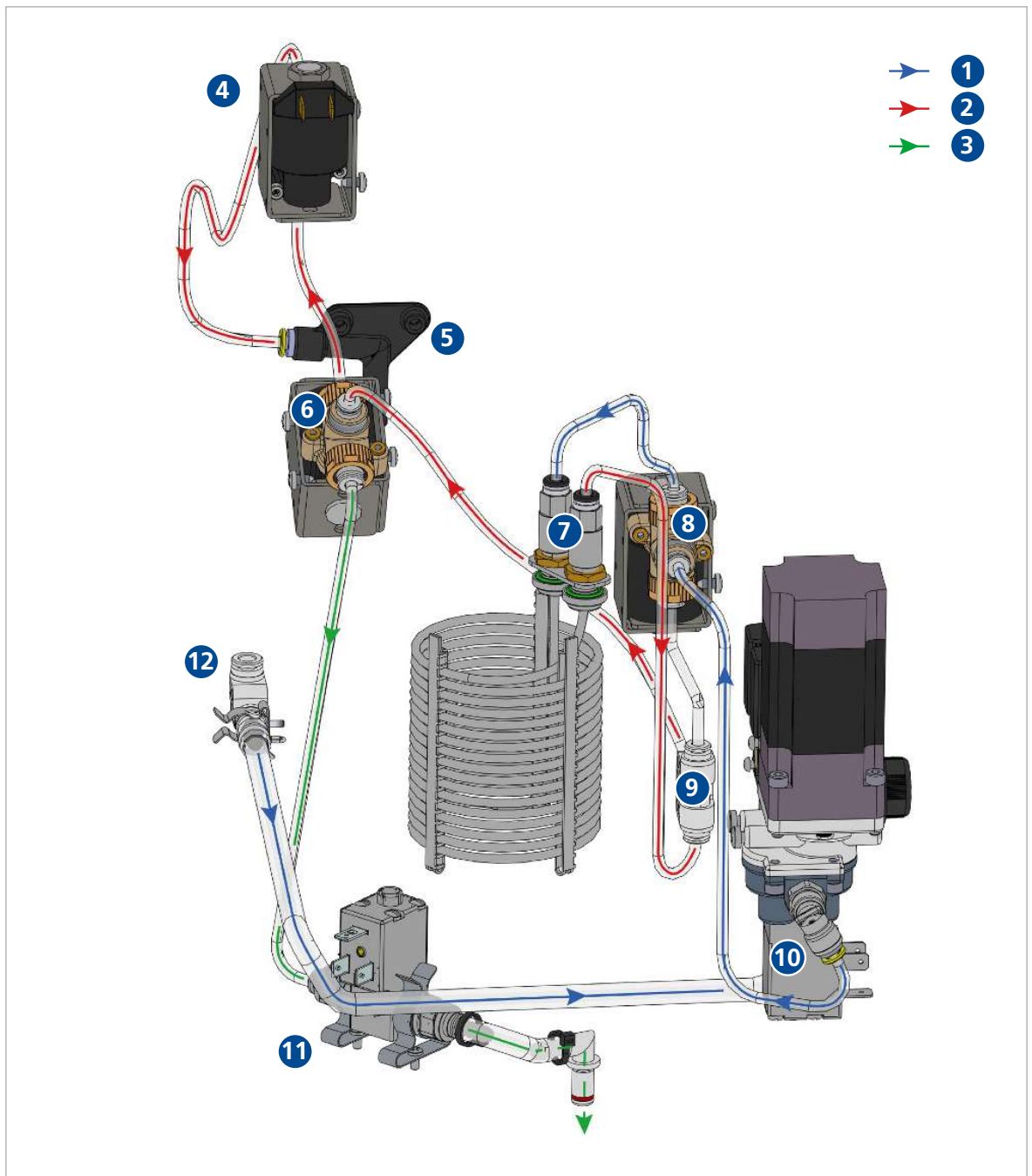

- | | |
|---------------------|---------------------------------|
| 1 Cold milk | 7 Milk heating coil |
| 2 Hot milk | 8 Cold milk valve |
| 3 Outlet | 9 Plug connection |
| 4 Venting valve | 10 Cleaning block milk pump |
| 5 Milk outlet | 11 Milk outlet valve |
| 6 Milk outlet valve | 12 Milk inlet from refrigerator |

6.9 Cold Milk Channel View II

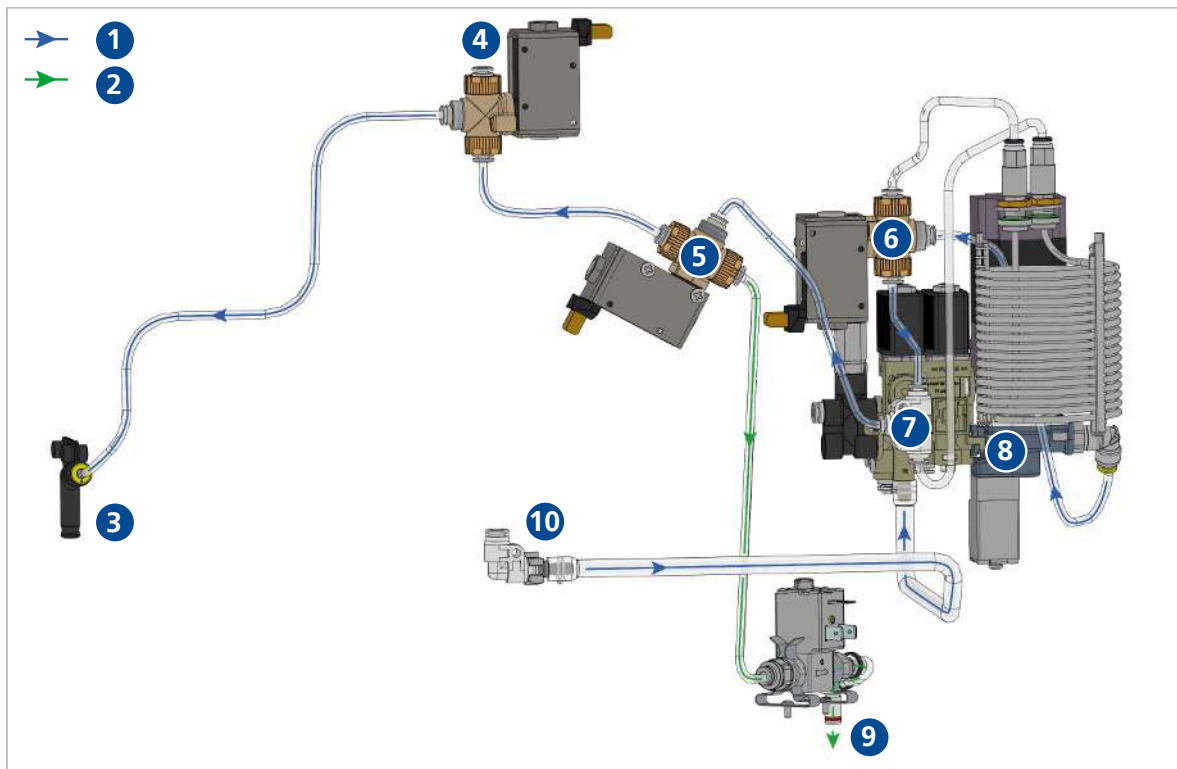

- | | |
|---------------------|----------------------------------|
| 1 Cold milk | 6 Cold milk valve |
| 2 Outlet | 7 Plug connection |
| 3 Milk outlet | 8 Cleaning block milk pump unit |
| 4 Venting valve | 9 Milk outlet valve |
| 5 Milk outlet valve | 10 Milk supply from refrigerator |

6.10 Hot Milk Channel View III

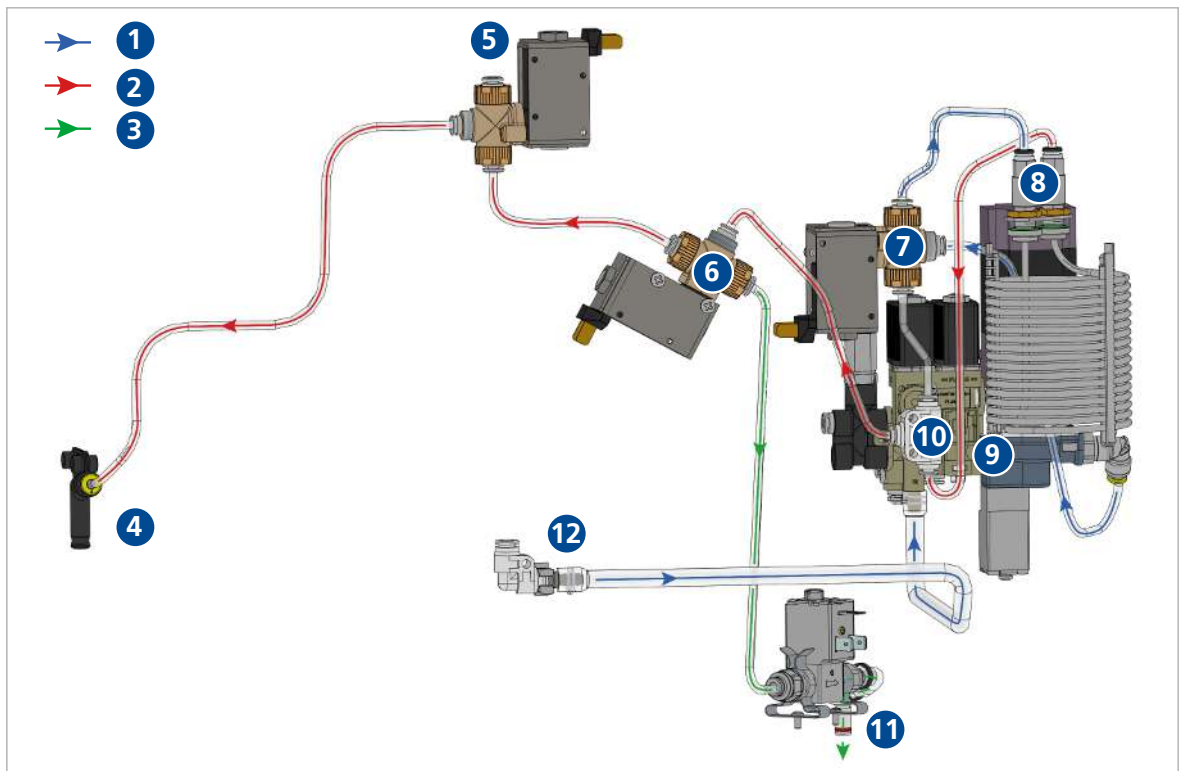

1 Cold milk

2 Hot milk

3 Outlet

4 Milk outlet

5 Venting valve

6 Milk outlet valve

7 Cold milk valve

8 Milk heating coil

9 Cleaning block milk pump unit

10 Plug connection

11 Milk outlet valve

12 Milk supply from refrigerator

7 Cleaning

7.1 Possible Errors

Messages	Possible Cause	Solution
Display message "Cleaning required in x:xx"	<ul style="list-style-type: none"> • Notice that the coffee machine will be blocked in x hours/minutes if this is not cleaned. • Coffee machine must be cleaned no later than 24 hours after preparing the first milk product. 	<ul style="list-style-type: none"> ▶ Start cleaning before the time has elapsed in order to prevent a blocking of the machine.
Display message "Cleaning required!"	<ul style="list-style-type: none"> • The machine was not cleaned despite the notice (see "Cleaning necessary in x:xx" display message). The coffee machine is blocked and must be cleaned before milk products can be prepared again. 	<ul style="list-style-type: none"> ▶ Clean the machine.
Display message "Cleaning in progress"	<ul style="list-style-type: none"> • Automatic cleaning is in progress. 	<ul style="list-style-type: none"> ▶ Wait until cleaning has been completed.
Display message "Cleaning interrupted!"	<ul style="list-style-type: none"> • Cleaning key was removed during cleaning. • Milk level hose was not in the milk container during cleaning. • Water flow interrupted. • Power interruption during cleaning. • Cleaning tablet valve defective or connected incorrectly. • Filter at the cleaning housing blocked. • The two 2.5 litre milk containers are in the refrigerator instead of the 5 litre cleaning containers. 	<ul style="list-style-type: none"> ▶ Do not remove cleaning key. Repeat cleaning. ▶ Milk level hose must be in the milk container during cleaning. Repeat cleaning. ▶ Check water channel. Repeat cleaning. ▶ Repeat cleaning. ▶ Check cleaning tablet valve in the service menu "Output test", check connections. ▶ Clean filter or replace if necessary.
Tablets have not dissolved	<ul style="list-style-type: none"> • The tablets used have exceeded the expiry date. • Cleaning tablet valve defective. • Water flow to cleaning tablets interrupted. 	<ul style="list-style-type: none"> ▶ Check expiry date of the tablets. Do not use any expired tablets. ▶ Check cleaning tablet valve in the service menu "Output test" and replace if necessary. ▶ Check water channel.

7.2 Cleaning Channel View I

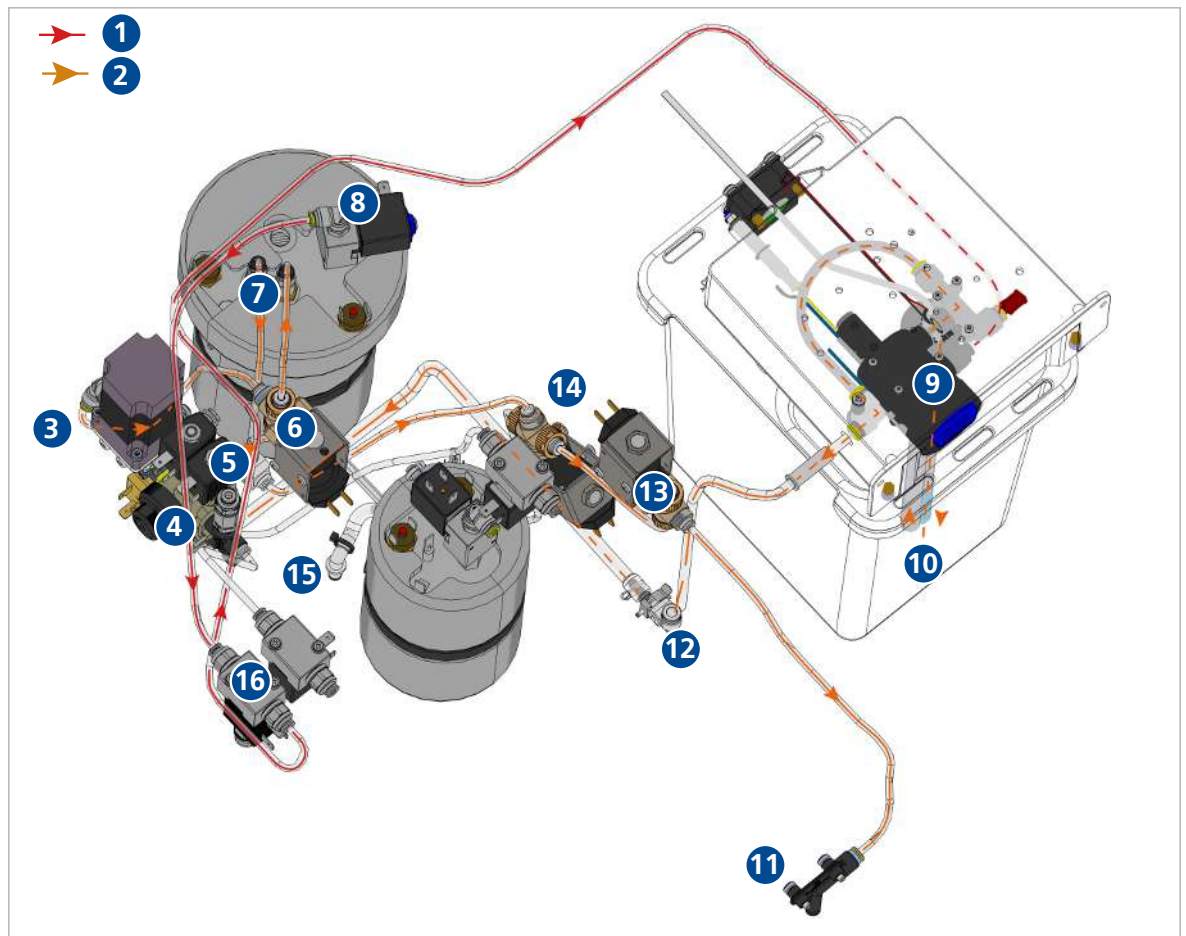

- | | |
|----------------------------|---------------------------|
| 1 Hot water | 9 Inlet milk cleaning key |
| 2 Cleaning mixture | 10 Water/tablet mixture |
| 3 Outlet milk pump | 11 Milk outlet |
| 4 Cleaning block milk pump | 12 Plug connection |
| 5 Plug connection | 13 Venting valve |
| 6 Cold milk valve | 14 Milk outlet valve |
| 7 Milk heating coil | 15 Outlet |
| 8 Tea valve | 16 Cleaning tablet valve |

7.3 Cleaning Channel View II

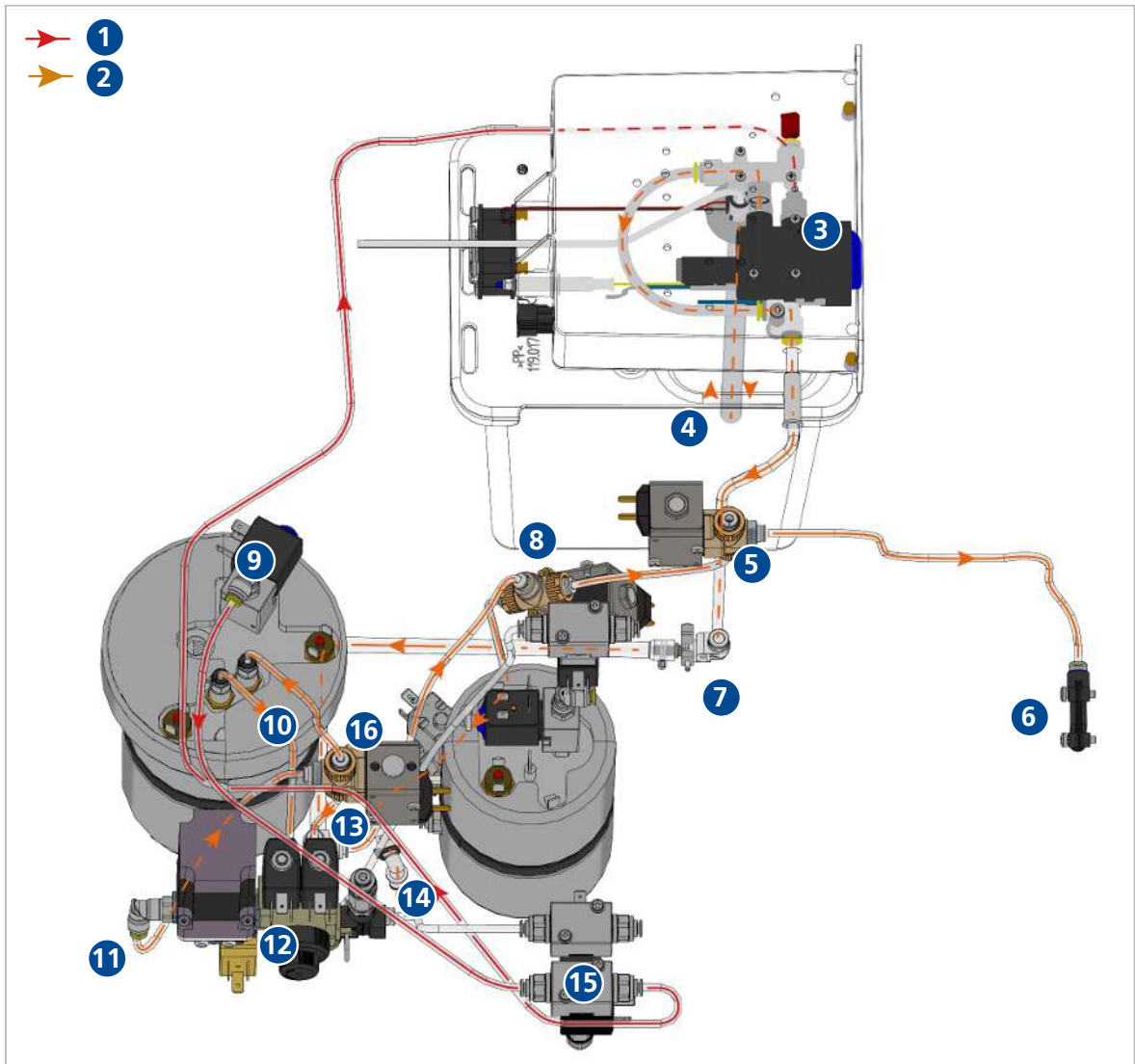

- | | |
|---------------------------|-----------------------------|
| 1 Hot water | 9 Tea valve |
| 2 Cleaning mixture | 10 Milk heating coil |
| 3 Inlet milk cleaning key | 11 Outlet milk pump |
| 4 Water/tablet mixture | 12 Cleaning block milk pump |
| 5 Venting valve | 13 Plug connection |
| 6 Milk outlet | 14 Outlet |
| 7 Plug connection | 15 Cleaning tablet valve |
| 8 Milk outlet valve | 16 Cold milk valve |

8 Electronics

8.1 Possible Problems

Messages	Possible Cause	Solution
Date no longer current	<ul style="list-style-type: none"> • 3V battery on CPU is empty. 	<ul style="list-style-type: none"> ▶ Replace battery.
Values are always rest to default	<ul style="list-style-type: none"> • CF card was left in. 	<ul style="list-style-type: none"> ▶ Switch off machine, remove CF card and switch machine on again.
Hieroglyphics on the display	<ul style="list-style-type: none"> • Intermediate print (only machines of the 1st production series) defective. • Cable connections between modules not OK. • Display defective. 	<ul style="list-style-type: none"> ▶ Replace intermediate print. ▶ Check connection, plug in again. ▶ If still not OK: Replace display.
No voltage main switch illuminates	<ul style="list-style-type: none"> • Connection cable not connected/loose contact. • Relay does not switch: stuck or defective. 	<ul style="list-style-type: none"> ▶ Check plug. ▶ Check/replace relay.
No 24V main switch illuminates	<ul style="list-style-type: none"> • 24V short-circuit. • Switching power supply/fuse on switching power supply defective. 	<ul style="list-style-type: none"> ▶ Eliminate 24V short-circuit. ▶ Check switching power supply/fuse and replace if necessary.
LEDs do not illuminate sometimes	<ul style="list-style-type: none"> • Cable connection or LED defective. 	<ul style="list-style-type: none"> ▶ Check cable (ribbon cable), replace cable or print.
Keyboard without function	<ul style="list-style-type: none"> • Software problem. • Keyboard cable not plugged in. • Capsule not tight, squirts on print. • Short-circuit. • Humidity too high. 	<ul style="list-style-type: none"> ▶ Update software. ▶ Check cable keyboard and cable print connection. Perform keyboard test: Press any key for 3s, perform keyboard test, test and check buttons. wait 3s to end the test. Replace print. ▶ Replace print. ▶ Remove keyboard, clean/dry thoroughly and reinstall. Check whether keyboard works, otherwise replace.
Display and keyboard dark, Main switch illuminates	<ul style="list-style-type: none"> • In standby mode. • Relay 4+1 defective. • Switching power supply/fuse on switching power supply defective. 	<ul style="list-style-type: none"> ▶ Press standby button. ▶ Check relay and replace if necessary. ▶ Check switching power supply/fuse and replace if necessary.
Display message "Powerboard error!"		

Messages	Possible Cause	Solution
Display message "No CompactFlash!"	<ul style="list-style-type: none"> • In the service menu "Save configuration" selected, but without CF card in the card slot. • CF card is not detected (defective?). 	<ul style="list-style-type: none"> ▶ Insert CF card into card slot. ▶ Try out another CF card.
Display message "CONFIG.BIN not found" Display message "EACBMAIN.BIN not found"	<ul style="list-style-type: none"> • No machine software found on CF card. • Machine software not loaded correctly to CF card. • CF card defective. 	<ul style="list-style-type: none"> ▶ Load software to CF card. ▶ Load machine software correctly to CF card (see Software Update Instructions). ▶ Try out another CF card.
Display message "Read error"	<ul style="list-style-type: none"> • No data on CF card that can be saved on machine. • File with backup data missing. • Data on CF card is defective or corrupted. • No communication with CF card. 	<ul style="list-style-type: none"> ▶ Copy machine software data to CF card. ▶ Save data again to CF card. ▶ Load machine software correctly to CF card (see Software Update Instructions). ▶ Check plug socket, use CF card from Thermoplan.
Display message "Write error"	<ul style="list-style-type: none"> • CF card improperly formatted. • No communication with CF card. 	<ul style="list-style-type: none"> ▶ Format CF card in FAT format. ▶ Check plug socket, use CF card from Thermoplan.
Display message "Machine resetted"	<ul style="list-style-type: none"> • Machine is in reset mode (it is reset to the default settings). 	<ul style="list-style-type: none"> ▶ Wait until reset has been fully implemented and "Heating up" or "Ready" appears on the display. ▶ Switch off the machine for 10 sec. ▶ Attention: customer-specific data will be lost!
Display message "Invalid file version!"		
Display message "CCI not connected!"	<ul style="list-style-type: none"> • CCI interface has been activated but not connected correctly or not connected. 	<ul style="list-style-type: none"> ▶ Connect interface correctly to machine.
Display message "No credit!"	<ul style="list-style-type: none"> • No product has been released by the cash register system for purchase. • Another product was selected than that which was released by the cash register system. 	<ul style="list-style-type: none"> ▶ Select the desired product for purchase. ▶ Select the product released for purchase.

8.2 Electronics Overview

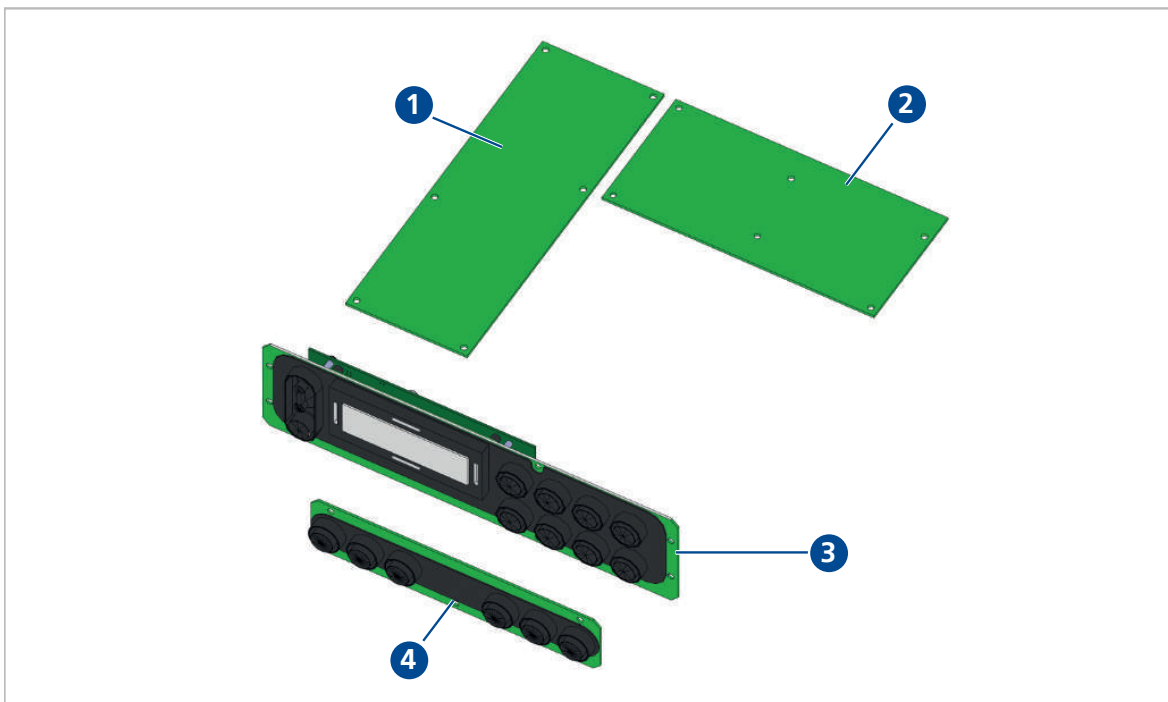

1 CPU

2 Power PCB

3 Keyboard with display (test/milk products)

4 Double outlet button (coffee products)

8.3 Connector Overview of Control Board (CPU)

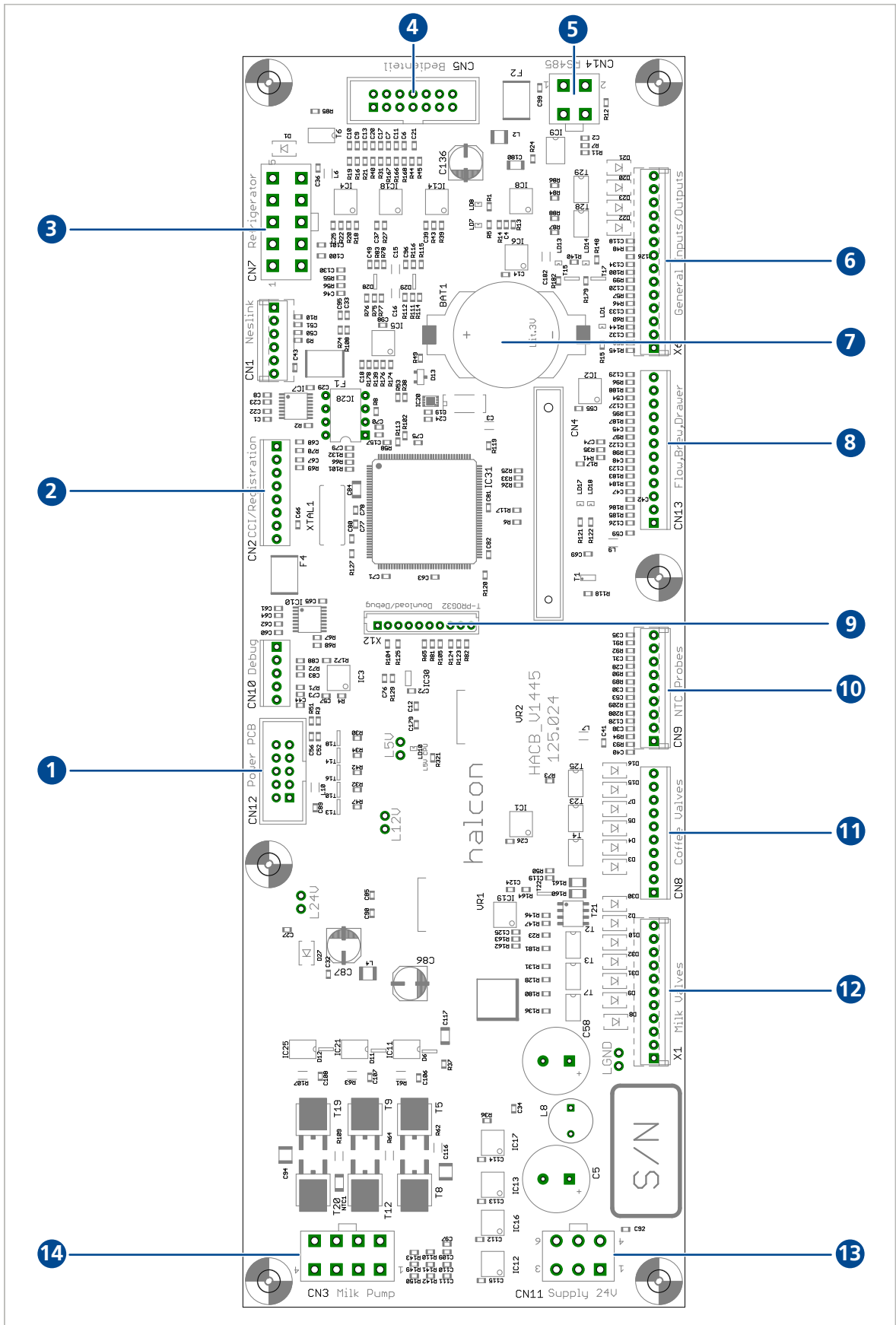

1 CN12, Supply 24VDC (HAPB)

8 CN13, Flow, Brew, Drawer

- 24 V Power supply from CUP via HAPB
- 2 CN2, CCI interface
- Connection for cash register system
- 3 CN7, refrigerator
- Level detector milk is empty
 - Level detector milk is almost empty
 - NTC Milk
 - 24V Fan
- Milk cleaning key
- 4 CN5, control panel
- Keyboard print
- 5 CN14 RS485 (external)
- Programming box
- 6 X6, General Inputs/Outputs
- Programming key for service menu
 - Energy saving mode button
 - Cleaning valve
 - Tea Valve 2
 - Venting valve
- 7 BAT1, 3V battery
- Real-time clock
- Flowmeter inlet coffee 1
 - Flowmeter inlet coffee 2
 - Detection of capsule collecting container
 - Brewing unit 1 microswitch
 - Brewing unit 2 microswitch
- 9 CN1, CF card slot
- CF card (software update)
- 10 CN9, NTC Probes (NTC probe)
- NTC Coffee boiler 1
 - NTC Coffee boiler 2
 - NTC tea/milk boiler
- 11 CN8 Coffee Valves
- Water inlet valve
 - Brewing valve 1
 - Brewing valve 2
 - Brewing chamber valve 1
 - Brewing chamber valve 2
 - Tea valve
- 12 X1, Milk Valves
- Milk outlet valve
 - Milk drain valve
 - Milk selection valve
 - Milk rinse valve
- 13 CN11, Power Supply 24V
- 24 V Power supply (switching power supply)
- 14 CN3, Milk Pump
- Milk pump control
 - (Hall sensors)

8.4 Connector Overview of Power Board (power PCB)

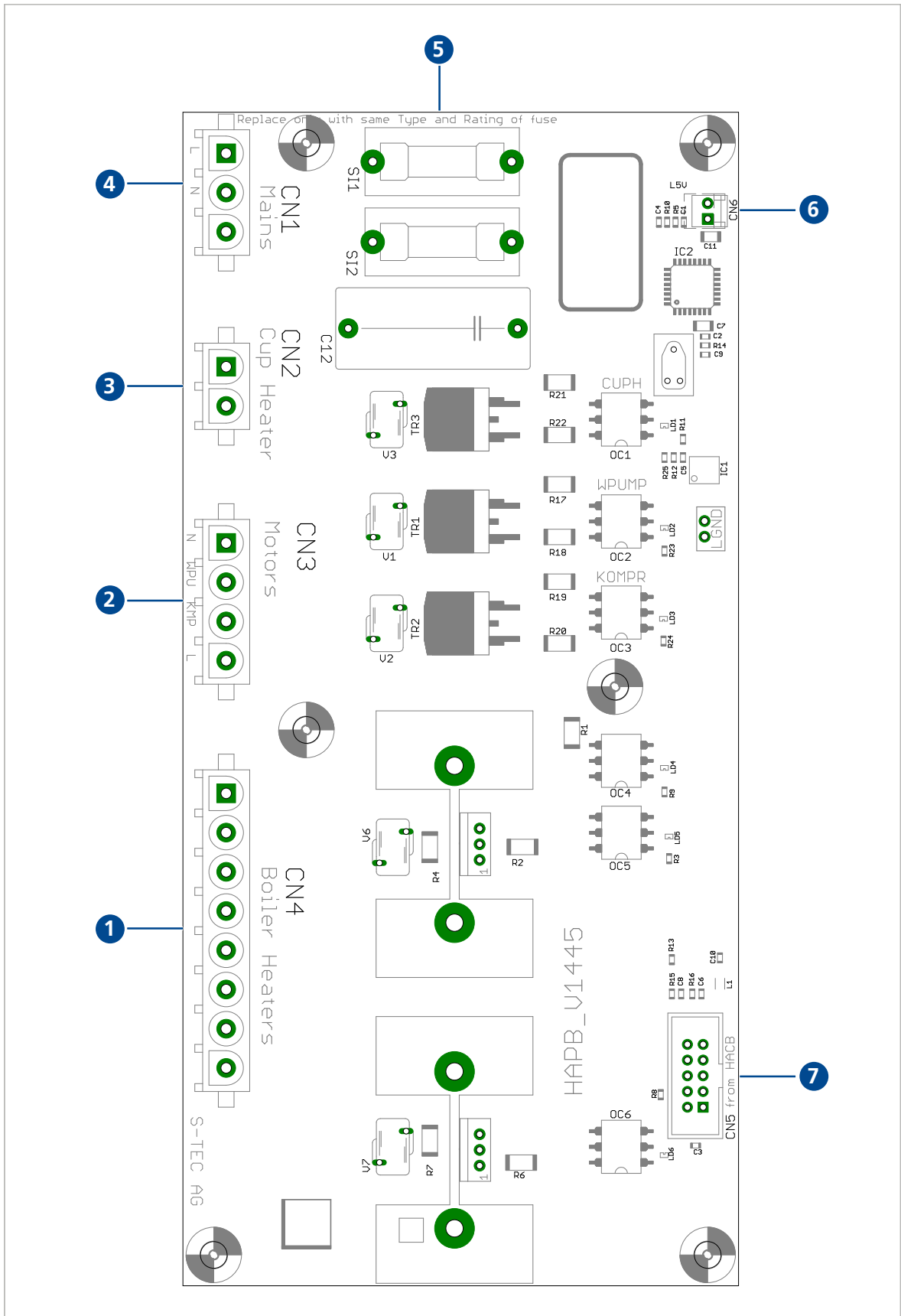

1 CN4, boiler heaters

5 SI1/SI2, fuses

- Heating control coffee boiler 1+2
 - Heating control tea/milk boiler
- 2 CN3, Motors
- Refrigerator fan 230V
 - Refrigerator compressor 230V
 - Water pump 230V
- 3 CN2, Cup heater
- Control for the cup heater
- 4 CN1, mains
- 230 V Power supply
- 6 CN6, refrigerator
- NTC refrigerator (inside temperature)
- 7 CN5, Supply 24VDC (HAPB)
- 24V Power supply (HAPB - HACB)

8.5 LED Overview of Control Board (CPU)

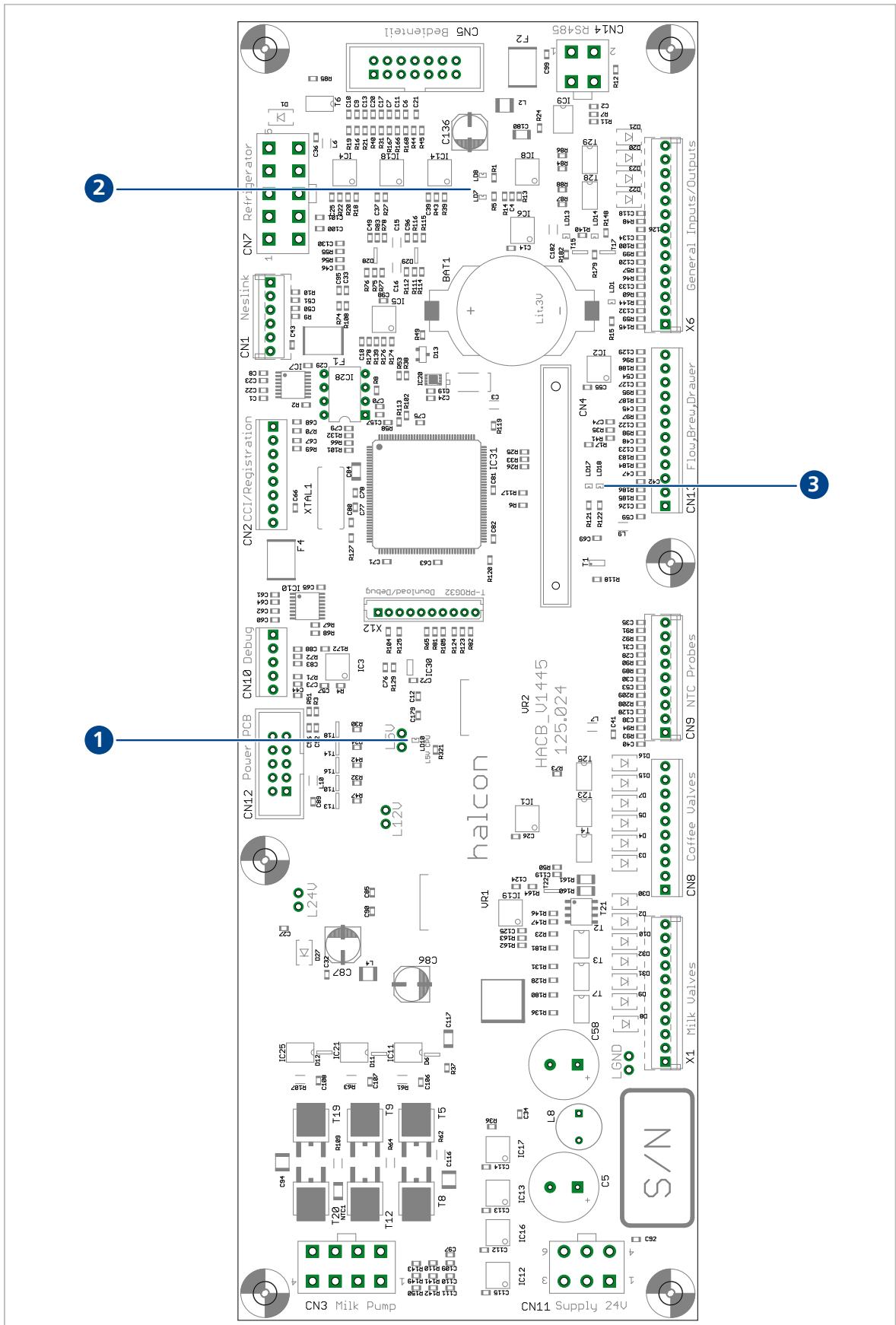

1 LD10: +5V Power Supply

3 LD17: CF card busy
LD18: CF card power

2 LD7/LD8: RS485 Rx/Tx

8.6 LED Overview of Power Board (power PCB)

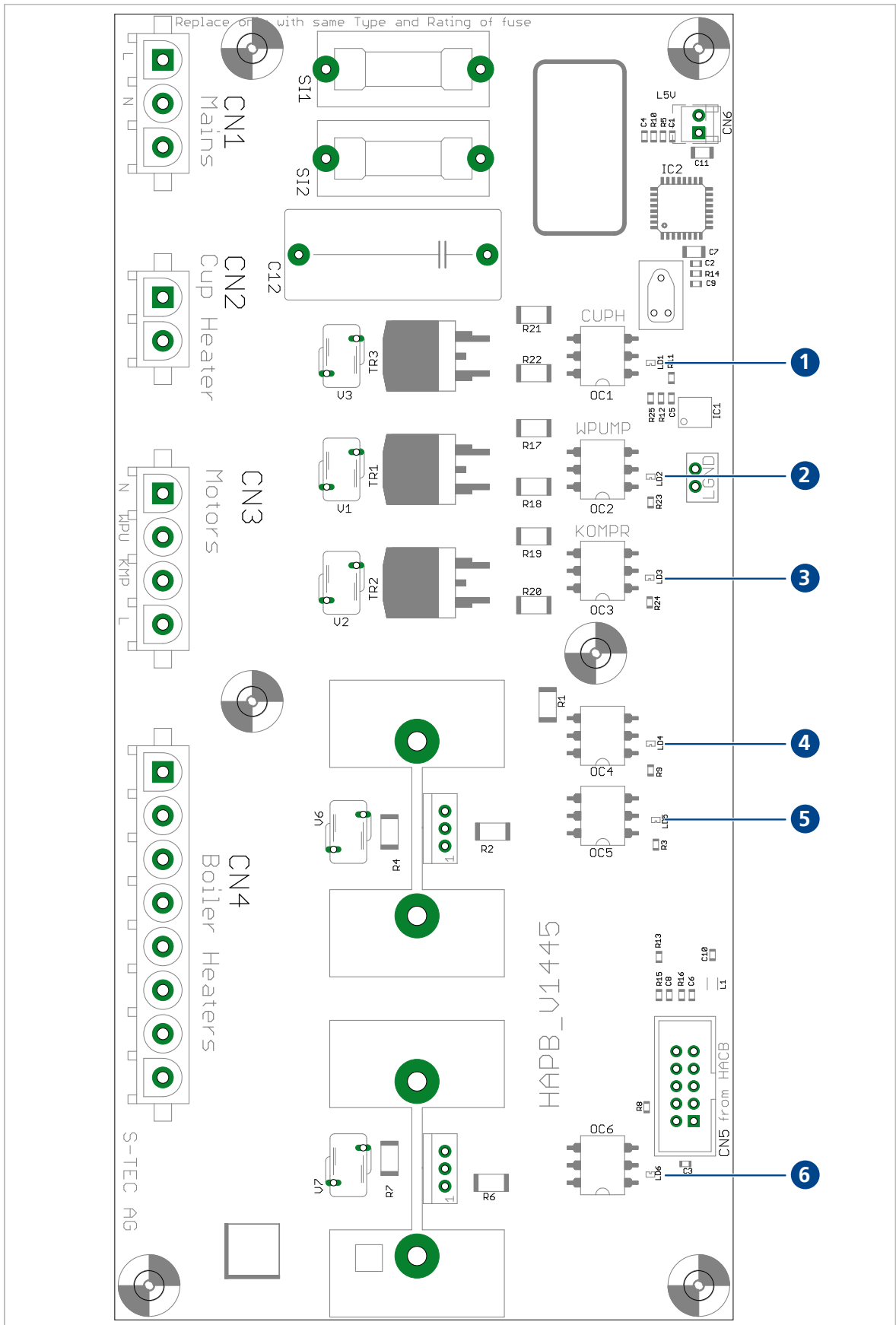

1 LD1: Cup heater

4 LD4: Tea/milk boiler

2 LD2: Water pump

5 LD5: Coffee boiler 1

3 LD3: Compressor

6 LD6: Coffee boiler 2

8.7 Display Messages

Messages	Possible Cause	Solution
Insert capsule drawer!	<ul style="list-style-type: none"> • Capsule container not inserted or not inserted correctly. • Reed contact defective. • Magnet on drawer missing. 	<ul style="list-style-type: none"> ▶ Insert capsule container correctly. ▶ Check reed with input test. ▶ Replace magnet.
Empty capsule drawer!	<ul style="list-style-type: none"> • Maximum number of capsules in capsule container reached. 	<ul style="list-style-type: none"> ▶ Empty capsule container and insert again.
Energy saving mode Press any key	<ul style="list-style-type: none"> • Coffee machine is in energy saving mode. 	<ul style="list-style-type: none"> ▶ Press any button to return to the operating mode.
	<ul style="list-style-type: none"> • Maximum Energy Saving Mode active • Machine is switched off (main switch in "OFF" position). 	<ul style="list-style-type: none"> ▶ Press energy saving button 3x to restart coffee machine. ▶ Switch on main switch.
Change water filter	<ul style="list-style-type: none"> • Filter cartridge is exhausted. 	<ul style="list-style-type: none"> ▶ Replace filter cartridge and reset water counter (service menu "Statistics" ▶ "Water volume Reset").
Service required	<ul style="list-style-type: none"> • Coffee machine has reached max. number of brews; 12 months since installation/last PM. 	<ul style="list-style-type: none"> ▶ Carry out PM and reset service counter.
Call technician	<ul style="list-style-type: none"> • Displayed to the user if NTC milk pump or flowmeter errors occur. • Repeated technical fault. 	<ul style="list-style-type: none"> ▶ Switch machine off and on again. Prepare product anew. ▶ Examine error trace and eliminate any recently occurred errors. ▶ Carry out irregular PM. Do not reset service counter!

thermoplan
Swiss Quality Coffee Equipment

Thermoplan AG
Thermoplan-Platz 1
6353 Weggis, Switzerland
Tel. +41 41 392 12 00
thermoplan@thermoplan.ch
www.thermoplan.ch