

# Service Menu

Technical Manual AG440



## Change Log

Revision	Date	Proof of Change	Initials
A	2017-07-07	First release, basic document	ZV
B	2022-03-01	Various changes	ZV

# Table of Contents

1	Access to Service Menu.....	4
2	Navigation/Making settings .....	6
2.1	Overview of the Programming Buttons .....	6
2.2	Making Parameter Settings .....	6
2.3	Example: Changing the Refrigerator Temperature .....	7
3	Listing of menu items.....	8
4	User Level.....	12
4.1	GENERAL SETTINGS.....	12
4.2	STATISTICS .....	12
4.3	MACHINE PARAMETERS .....	13
4.4	MILK SETTINGS.....	13
5	Technician Level.....	14
5.1	GENERAL SETTINGS.....	14
5.2	STATISTICS .....	23
5.3	MACHINE PARAMETERS .....	25
5.4	ENERGY SAVING MODE.....	25
5.5	MILK SETTINGS.....	26
5.6	COFFEE BOILER .....	27
5.7	TEA/MILK BOILER .....	28
5.8	CLEANING PARAMETERS.....	28
5.9	OUTPUT TEST .....	29
5.10	INPUT TEST.....	31
5.11	Products .....	33
5.12	ERROR TRACE .....	36

# 1 Access to Service Menu

The Aguila coffee machine provides two different software menu levels. At the user level, only very few settings can be changed, e.g. the language.

At the technician level, all setting options are available. The programming key required for entering the menu may only be in the possession of the technician!

## User Level



- ▶ Keep the rinse button pressed for approx. 3 seconds.
- ⇒ Service menu is entered as user.



- ▶ Press cancel button (Lungo button) repeatedly until the start display ("Ready") appears.
- ⇒ Service menu is exited as user.

## Technician Level

- ▶ Remove capsule container on the left module.

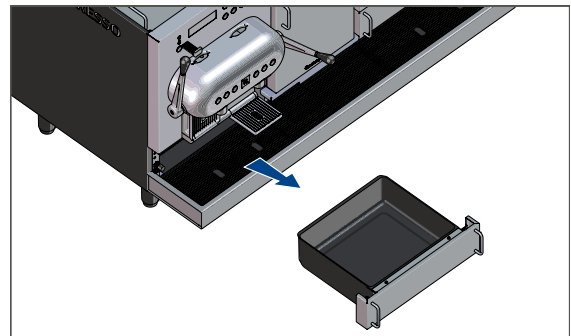

- ▶ Insert programming key in the rear area of the drawer and turn clockwise.
- ⇒ Service menu was entered as technician and the water inlet valve was opened. Upon exiting the technician menu, the water inlet valve is closed again.



- ▶ In the service menu, navigate to the menu item "Input test left/right" or "Output test left/right".



TECHNICIAN MENU  
<INPUT TEST LEFT>



TECHNICIAN MENU  
<OUTPUT TEST LEFT>

- ▶ Turn programming key anticlockwise and remove.
  - ⇒ Start display ("Ready") appears again.
  - ⇒ Service menu was exited as technician.

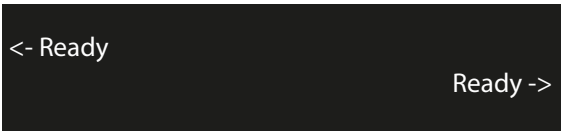

<- Ready

Ready ->

## 2 Navigation/Making settings

The left side of the device module is always used to navigate in the service menu. All settings carried out on the machine (master module) to the left always affect the entire machine.

### 2.1 Overview of the Programming Buttons

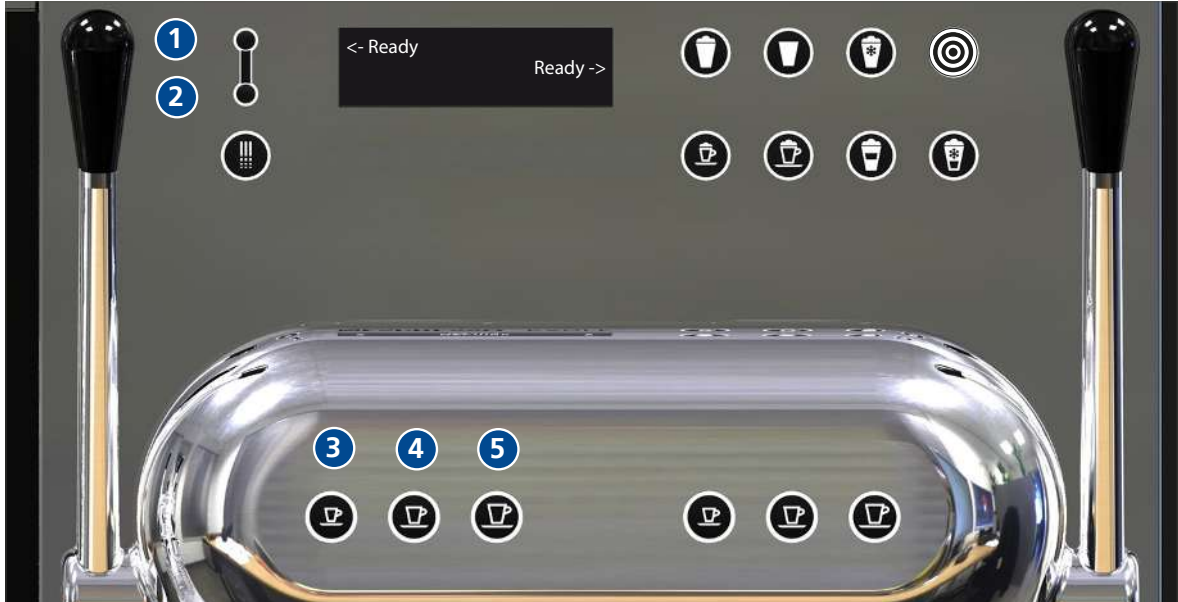



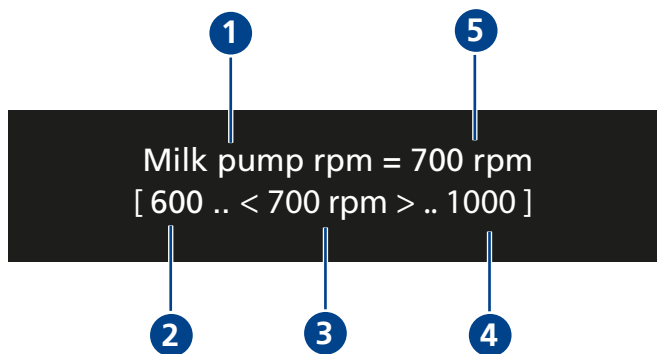

- 1 Up (Cleaning button): next menu/increase value
- 2 Down (rinse button): Previous menu/decrease value
- 3 Standard (Ristretto button): Set default value
- 4 Input (Espresso button): Edit/Confirm
- 5 Cancel (Lungo button): exit menu/cancel







### 2.2 Making Parameter Settings

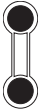

- 1 Parameter name
- 2 Min value
- 3 Current value
- 4 Max value
- 5 Value before entering the menu

-  ▶ Press button to increase or decrease the value.
-  ▶ Press red flashing Ristretto button.  
⇒ Default value is loaded from the CPU.
-  ▶ Press white flashing Espresso button.  
⇒ The new setting is saved.
-  ▶ Press red flashing Lungo button.  
⇒ Menu is exited without saving.

### 2.3 Example: Changing the Refrigerator Temperature

<ul style="list-style-type: none"> <li>▶ Enter user or technician level (see <a href="#">[Access to Service Menu ▶ 4]</a>).</li> </ul>	TECHNICIAN MENU < GENERAL SETTINGS >
<ul style="list-style-type: none"> <li> ▶ Switch to the "MILK SETTINGS" menu with the Up or Down button (cleaning or rinsing button).</li> </ul>	TECHNICIAN MENU < MILK SETTINGS >
<ul style="list-style-type: none"> <li> ▶ Press input button (Espresso button). ⇒ "MILK SETTINGS" menu opens.</li> </ul>	MILK SETTINGS Milkpump RPM = 700 RPM
<ul style="list-style-type: none"> <li> ▶ Switch to the "Refrigerator temperature" menu with the Up or Down button (cleaning or rinsing button).</li> </ul>	TECHNICIAN MENU Refrigerator temp. = 5.0°C
<ul style="list-style-type: none"> <li> ▶ Press input button (Espresso button). ⇒ "Refrigerator temperature" menu opens.</li> </ul>	Refrigerator temp. = 5.0 °C [ 4.0 .. < 5.0 °C > .. 8.0 ]
<ul style="list-style-type: none"> <li> ▶ Use the Up or Down button (cleaning or rinsing button) to adjust the value as required.</li> </ul>	
<ul style="list-style-type: none"> <li> ▶ If the set value is changed, the default button (Ristretto button) starts flashing.</li> <li>▶ Press default button. ⇒ Value is reset to the default value.</li> </ul>	Refrigerator temp. = 5.0 °C [ 4.0 .. < 5.0 °C > .. 8.0 ]
<ul style="list-style-type: none"> <li> ▶ Press input button (Espresso button) to confirm the selection. ⇒ The new selection is applied and the higher menu level appears again.</li> </ul>	TECHNICIAN MENU Refrigerator temp. = 4.0°C
<ul style="list-style-type: none"> <li>▶ Exit user or technician level (see <a href="#">[Access to Service Menu ▶ 4]</a>).</li> </ul>	<- Ready <span style="float: right;">Ready -&gt;</span>

### 3 Listing of menu items

Main menu	Submenu
GENERAL SETTINGS	<ol style="list-style-type: none"> <li>1. Language</li> <li>2. &lt;- Aguila+</li> <li>3. Aguila+ -&gt;</li> <li>4. Time</li> <li>5. Date</li> <li>6. Global reset</li> <li>7. Save configuration</li> <li>8. Load configuration</li> <li>9. Load firmware</li> <li>10. Milk temp. indicator</li> <li>11. Emptying sequence</li> <li>12. Demo mode</li> <li>13. Display boiler temp</li> <li>14. Display flowmeter</li> </ol>
STATISTICS	<ol style="list-style-type: none"> <li>1. User product counter</li> <li>2. User capsule counter</li> <li>3. User counter reset</li> <li>4. Service product counter</li> <li>5. Service counter reset</li> <li>6. Products total</li> <li>7. Capsule counter</li> <li>8. Water quantity</li> <li>9. Water quantity reset</li> <li>10. Cleaning procedures</li> <li>11. Cancel. Cleaning procedures</li> <li>12. Brewing unit 1</li> <li>13. Brewing unit 2</li> <li>14. Brewing unit 3</li> <li>15. Brewing unit 4</li> <li>16. Brewing unit 1 reset</li> <li>17. Brewing unit 2 reset</li> <li>18. Brewing unit 3 reset</li> <li>19. Brewing unit 4 reset</li> </ol>
MACHINE PARAMETERS	<ol style="list-style-type: none"> <li>1. Filter change</li> <li>2. Products max.</li> <li>3. Service interval</li> <li>4. BU max. products</li> <li>5. Valve delay</li> </ol>

Main menu	Submenu
	<ul style="list-style-type: none"> <li>6. Power Manager</li> <li>7. Capsule capacity</li> <li>8. Drawer reset time</li> <li>9. Min. coffee flow</li> <li>10. Max. coffee flow</li> <li>11. Cup heater</li> <li>12. Cup heater</li> </ul>
ENERGY SAVING MODE	<ul style="list-style-type: none"> <li>1. Time until mode 1</li> <li>2. Time until mode 2</li> <li>3. Enter after cleaning</li> </ul>
MILK SETTINGS	<ul style="list-style-type: none"> <li>1. Milk pump rpm</li> <li>2. Foam pump rpm left</li> <li>3. Foam pump rpm right</li> <li>4. Rinse pump rpm</li> <li>5. Cooling temperature</li> <li>6. Hot foam left</li> <li>7. Hot foam right</li> <li>8. Cold foam left</li> <li>9. Cold foam right</li> </ul>
COFFEE BOILER	<ul style="list-style-type: none"> <li>1. Set temperature left</li> <li>2. Set temperature right</li> <li>3. Temp. tolerance</li> </ul>
TEA/MILK BOILER	<ul style="list-style-type: none"> <li>1. Set temperature left</li> <li>2. Set temperature right</li> <li>3. Temp. tolerance</li> </ul>
CLEANING PARAMETERS	<ul style="list-style-type: none"> <li>1. Locktime</li> </ul>
OUTPUT TEST LEFT	<ul style="list-style-type: none"> <li>1. Water inlet valve</li> <li>2. Chamber release valve 1</li> <li>3. Chamber release valve 2</li> <li>4. Brew valve 1</li> <li>5. Brew valve 2</li> <li>6. Tea valve1</li> <li>7. Tea valve2</li> <li>8. Exhaust valve</li> <li>9. Milk cleaning valve</li> <li>10. Milk rinse valve</li> <li>11. Cold milk valve</li> <li>12. Milk outlet valve</li> <li>13. Milk drain valve</li> <li>14. Milk air Valve</li> </ul>

Main menu	Submenu
	15. Water pump 16. Milk pump 17. Coffee boiler 1 18. Coffee boiler 2 19. Tea/milk boiler 20. Cup heater
OUTPUT TEST RIGHT	1. Cleaning-tablet valve 2. Chamber release valve 1 3. Chamber release valve 2 4. Brew valve 1 5. Brew valve 2 6. Tea valve1 7. Tea valve2 8. Exhaust valve 9. Milk cleaning valve 10. Milk rinse valve 11. Cold milk valve 12. Milk outlet valve 13. Milk drain valve 14. Milk air valve 15. Water pump 16. Milk pump 17. Fridge Fan 18. Coffee boiler 1 19. Coffee boiler 2 20. Tea/milk boiler 21. Cup heater
INPUT TEST LEFT	1. Drawer 2. Cleaning key 3. Cleaning tablet 4. Brew chamber 1 5. Brew chamber 2 6. NTC boiler 1 7. NTC boiler 2 8. NTC boiler 3 9. NTC cooling 10. Flow 1 11. Flow 2 12. Milk temperature 13. Milk level low

Main menu	Submenu
	<ul style="list-style-type: none"> <li>14. Milk container empty</li> <li>15. Standby button</li> </ul>
INPUT TEST RIGHT	<ul style="list-style-type: none"> <li>1. Drawer</li> <li>2. Brew chamber 1</li> <li>3. Brew chamber 2</li> <li>4. NTC boiler 1</li> <li>5. NTC boiler 2</li> <li>6. NTC boiler 3</li> <li>7. Flow 1</li> <li>8. Flow 2</li> <li>9. Milk temperature</li> <li>10. Milk level low</li> <li>11. Milk container empty</li> </ul>
PRODUCTS	<ul style="list-style-type: none"> <li>1. Coffee ticks</li> <li>2. Hot water</li> <li>3. Hot water right</li> <li>4. Hot water left</li> <li>5. Pre-brewing time</li> <li>6. Sleep mode</li> <li>7. Milk type</li> <li>8. Milk time</li> <li>9. Milk time left</li> <li>10. Milk time right</li> <li>11. Foam type</li> <li>12. Foam time</li> <li>13. Foam time left</li> <li>14. Foam time right</li> <li>15. Air hot</li> <li>16. Air cold</li> <li>17. Add milk</li> <li>18. Add foam</li> <li>19. Coffee supply</li> </ul>
ERROR TRACE	<ul style="list-style-type: none"> <li>1. Clear error history</li> <li>2. #1 =dd.mm.yyyy</li> </ul>
INSTALLATION	<ul style="list-style-type: none"> <li>1. CCI</li> <li>2. Software Version</li> <li>3. Powerboard left</li> <li>4. Powerboard right</li> <li>5. Bootloader</li> <li>6. Textfile</li> </ul>

## 4 User Level

The user level only allows a limited selection of settings. All user level settings are also included in the technician level.

### 4.1 GENERAL SETTINGS

If the service menu is entered at the user level, it is possible under "GEN. SETTINGS" to change the language, for example.

- ▶ Change the language to display all display texts in the selected language.

Language = English  
< English >

- ▶ Select the product which is output when pressing the left or right Aguila+ button.

- ⇒ Selection: Cortado Lungo, Cortado, Flat White, Cappuccino Lungo, Cappuccino Chiaro, Cappuccino Freddo, Iced Cappuccino, Latte Grande, Latte, Latte Piccolo, Iced Latte, Macchiatissimo, Cold Milk.

AGUILA+  
< LATTE >

### 4.2 STATISTICS

Under "STATISTICS" the counters of the individual products can be queried and reset.

- ▶ Query user counters of the individual products.

STATISTICS  
User product counter

- ▶ Press product.

- ⇒ Counter is displayed.

- ⇒ The current counter reading of the corresponding module appears on both displays.

User product counter  
< Choose a product >

- Display above: name and quantity of the product.
- Display bottom left: prepared quantity of the selected product from the left outlet.
- Display bottom right: prepared quantity of the selected product from the right outlet.
- ▶ Displays the total prepared capsule products.

Espresso = 57  
<-- 31 26 -->

- ▶ Reset user counter to 0.

- ▶ Change the value to "Yes" with the Up/Down button.

- ▶ Confirm with the entry button.

STATISTICS  
Capsulecounter user =

STATISTICS  
User counter reset

- The total number of all prepared products is displayed.
- The total number of all prepared capsule products is displayed.

STATISTICS  
Product counter =

STATISTICS  
Capsule products counter =

### 4.3 MACHINE PARAMETERS

In this menu the cup heater can be switched on or off.

- ▶ Set cup heater.
  - ⇒ "On": Cup heater of the machine is activated.
  - ⇒ "Off": Cup heater of the machine is deactivated.

Cup heater = On  
< On >

### 4.4 MILK SETTINGS

In the "MILK SETTINGS" menu the refrigerator temperature can be adjusted.

- ▶ Enter value that determines the temperature inside the refrigerator.
- ▶ Adjust the percentage of air content required to change the fluidity of the hot milk foam.
  - ⇒ A lower value results in more fluid foam.
  - ⇒ A higher value results in more solid foam.
- This value is reset to 0.0 % as soon as the settings for "hot air" in the technician level under "Products" are adjusted.
- The foam setting can be adjusted differently on the right and left.
- ▶ Adjust the percentage of air content required to change the fluidity of the cold milk foam.
  - ⇒ A lower value results in more fluid foam.
  - ⇒ A higher value results in more solid foam.
- This value is reset to 0.0 % as soon as the settings for "cold air" in the technician level under "Products" are adjusted.
- The foam setting can be adjusted differently on the right and left.

Refrigerator temp. = 5.0 °C  
[ 4.0 .. < 5.0 °C > .. 8.0 ]

Hot foam left = 0.0 %  
[ -10.0 .. < 0.0 % > .. 10.0 ]

Hot foam right = 0.0 %  
[ -10.0 .. < 0.0 % > .. 10.0 ]

Cold foam left = 0.0 %  
[ -10.0 .. < 0.0 % > .. 10.0 ]

Cold foam right = 0.0 %  
[ -10.0 .. < 0.0 % > .. 10.0 ]

## 5 Technician Level

In the service menu at technician level all settings can be adjusted, such as the products and machine parameters.

### 5.1 GENERAL SETTINGS

In this menu, for example, the language and date can be adjusted, and a new software version can be installed.

- ▶ Change the language to display all display texts in the selected language.

Language = English  
< English >

- ▶ Set time.
- ▶ Press input button to change the input of minutes.
- ▶ Press input button to confirm.

Time = 12:00  
<12>:00

- ▶ Set date.
- ▶ Press input button to switch between day, month and year.
- ▶ Press input button to confirm.
- ▶ Change temperature unit between °C (Celsius) and °F (Fahrenheit).

Date = 26.08.2014  
<26>.08.2014

- ▶ Empty all boilers.
- ▶ Change value to "Yes" with the Up/Down button.
- ▶ Confirm with the entry button.
- ▶ Follow instructions on the display.
- ▶ For demonstration purposes: the machine is inoperable, all heaters are switched off.
  - ⇒ The display is enabled and displays "Ready".
  - ⇒ All product buttons illuminate but do not function.

Emptying Sequence  
< No >

- ▶ Enable to display the temperature of the boiler on the display (only in "Ready" mode).

Show boiler temp. = No  
< No >

- ▶ Enable to display speed of the flowmeter on the display (only in "Ready" mode).

Show flowmeter = No  
< No >

### 5.1.1 Formatting CF cards

- ▶ Check compact flash card from Thermoplan.
  - Art. No. 117.072

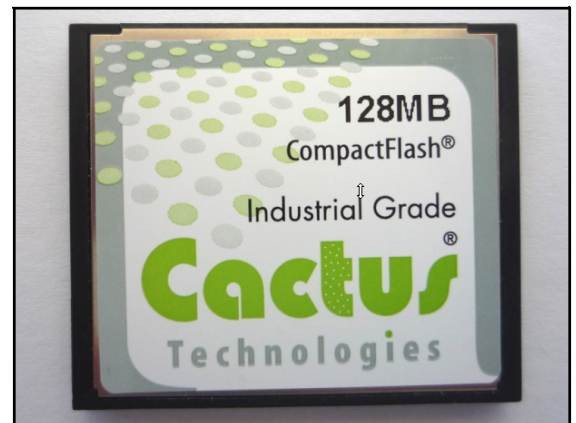

- ▶ Insert CF card in card reader.
  - ⇒ «Automatic playback» window appears.

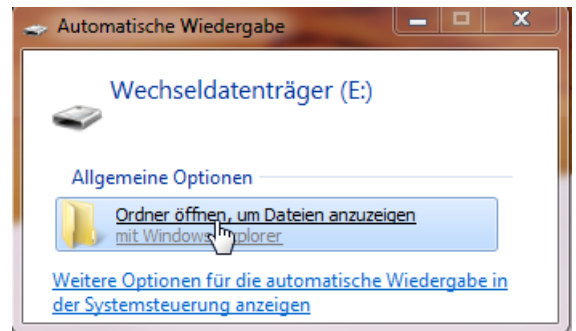

- ▶ «Click on open folder to display files».
  - ⇒ Windows Explorer opens.
  - ⇒ Removable storage device or CF card is displayed.

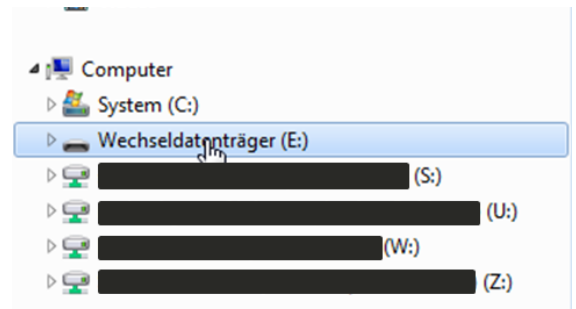

- ▶ Select removable storage device with right mouse button.
- ▶ Click on format.
  - ⇒ A window with automatically set formatting options appears.

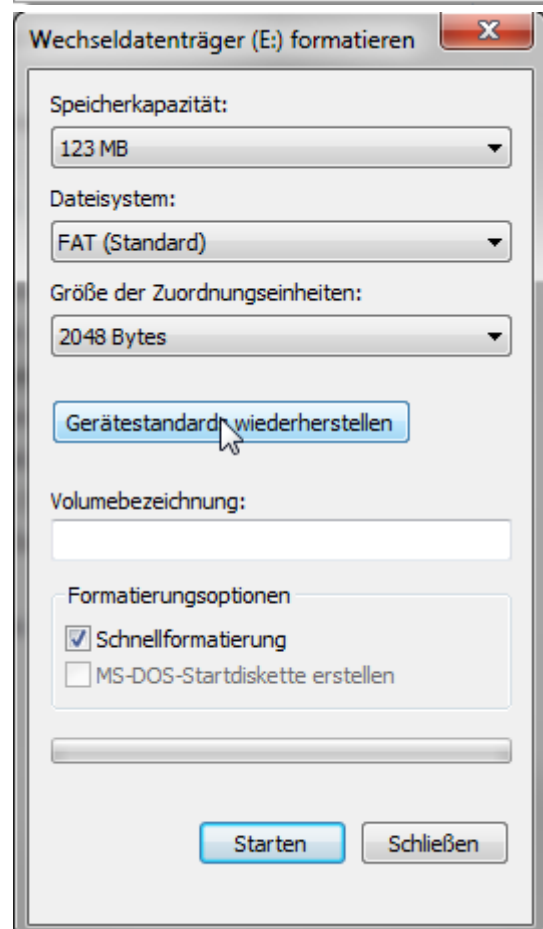
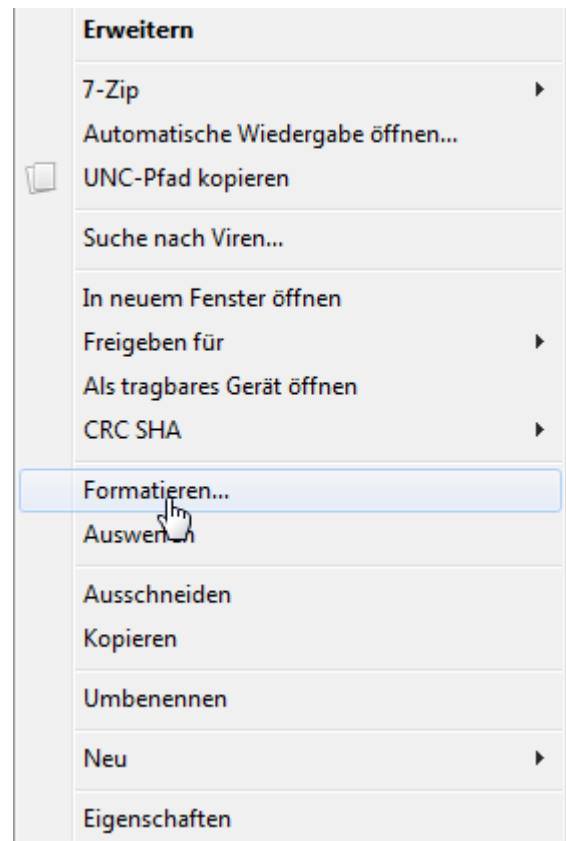

- ▶ Remove checkmark at quick formatting.
- ▶ Click on «Restore device standards».
  - ⇒ «Size of allocation units» changes from 2048 bytes to standard size.
- ▶ Click on «Start».
  - ⇒ Window with a warning appears.

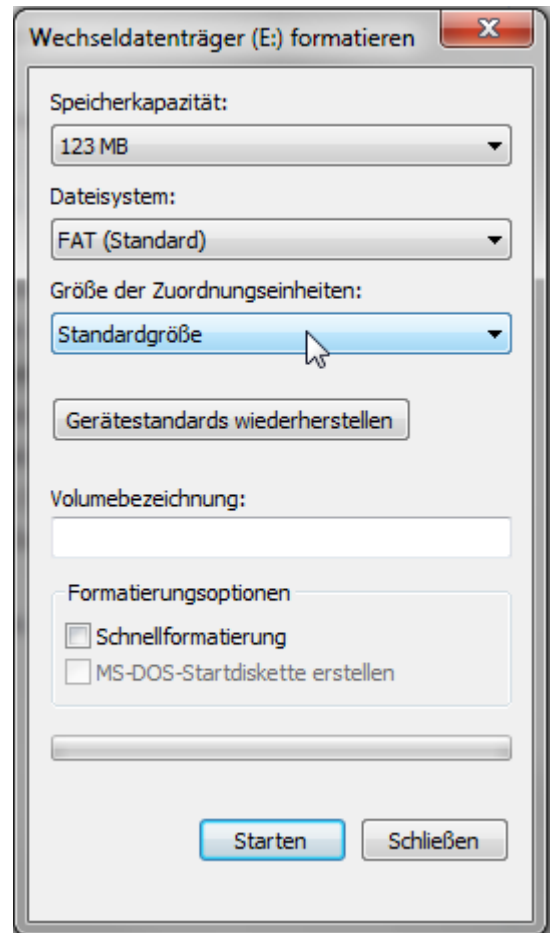

- ▶ Confirm with OK.
  - ⇒ Formatting runs.
  - ⇒ «Formatting completed» window appears.
- ▶ Confirm with OK.

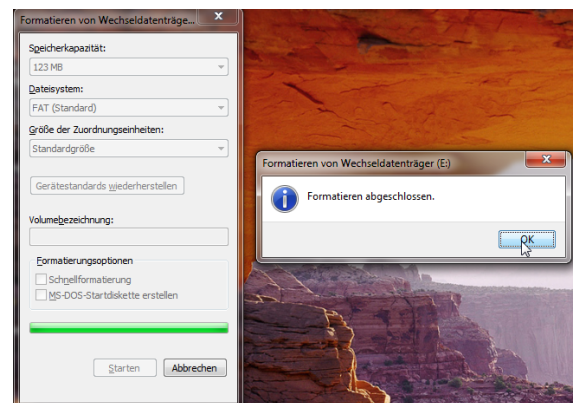
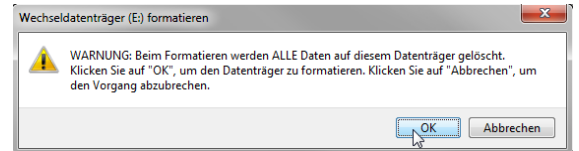

- ▶ Close «formatting options» window.  
⇒ Formatting is completed.

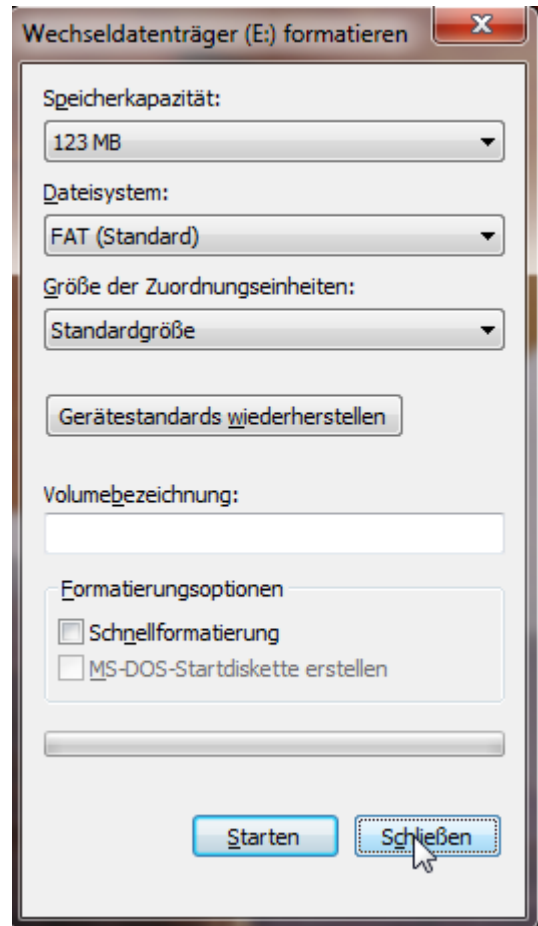

- ▶ Click on arrow for the hidden symbols.  
• Desktop bottom right.



- ▶ Click on USB connection symbol.  
⇒ Window with connected storage media appears.

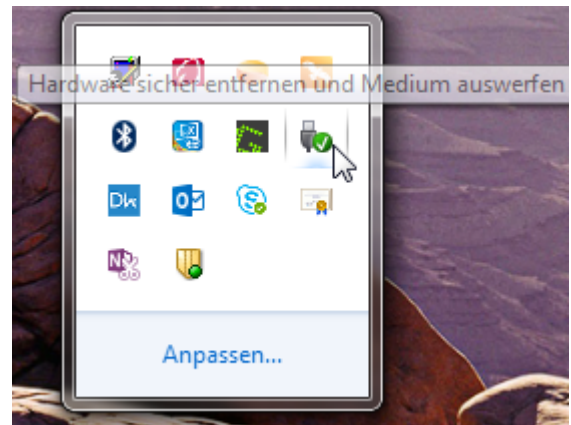

- ▶ Click on the storage media to be removed.
- ▶ This process has successfully been completed when the window with the message «Hardware can now be removed» appears.

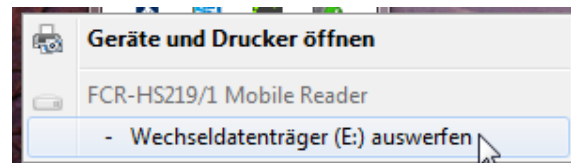

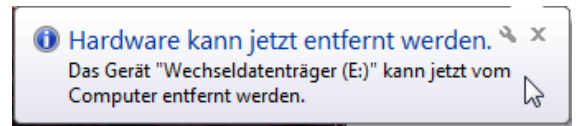

- ▶ Remove CF card.
  - ⇒ The CF card can now be used to save new software or the configuration of the AG440 on it.

### 5.1.2 Saving software

- ▶ Check formatted compact flash card from Thermoplan.
  - Art. No. 117.072
- ▶ Use the latest software.
  - Art. No. 129.452

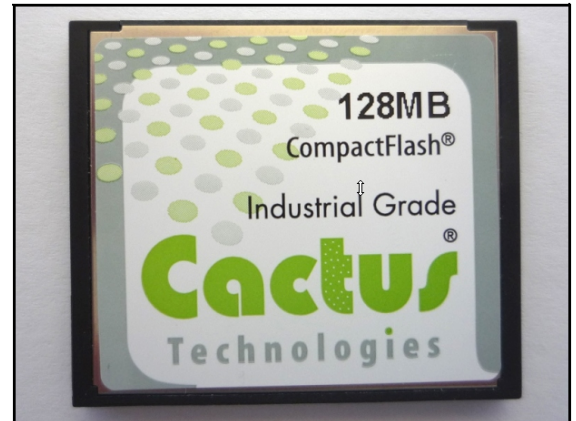

- ▶ Download and save the latest software from Thermoplan.
  - ⇒ Zip folder is saved.
- ▶ Click the right mouse button on the software folder to extract the folder.
  - ⇒ A window appears.
- ▶ Click on «Extract all».
  - ⇒ A window appears with the storage location for the file to be extracted.

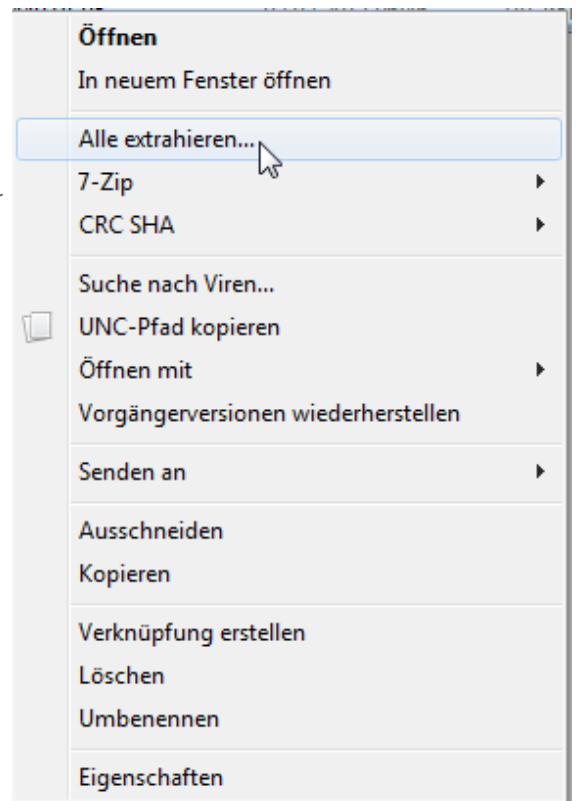

- ▶ Select storage location.
- ▶ Click on «Extract».

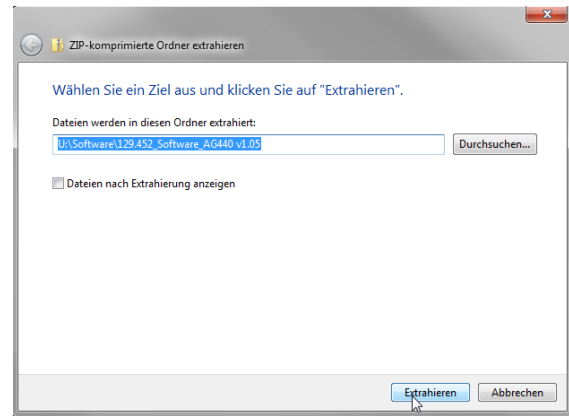

- The «FIRMWARE» folder containing the actual software is located in the extracted folder.
- ▶ Click on the «FIRMWARE» folder with the right mouse button.
- ▶ Click on Copy.

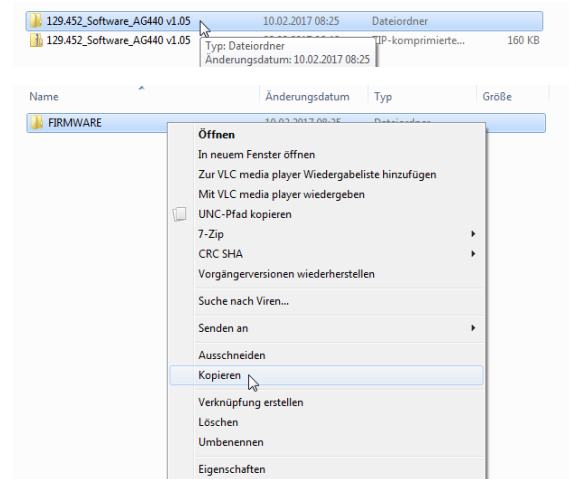

- ▶ Click on formatted removable storage device or CF card.
  - ⇒ An empty file folder of the CF card appears.

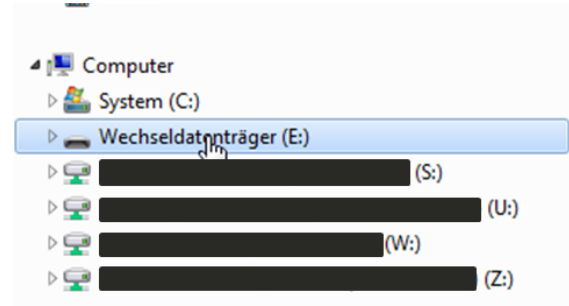

- ▶ Click on the empty area with the right mouse button.
- ▶ Click on «Insert» to insert the «FIRMWARE» folder on the CF card.
  - ⇒ The «FIRMWARE» folder is on the CF card.
- ▶ Check the folder structure on the CF card.
  - Only the «FIRMWARE» folder on the CF card (everything in capital letters).
- ▶ Click on "FIRMWARE".
  - There are 4 files are in the folder (HACB1432.BIN, HACB1432.BOL, HACBREG1.BIN, HACBREG2.BIN).
  - Software correctly saved.

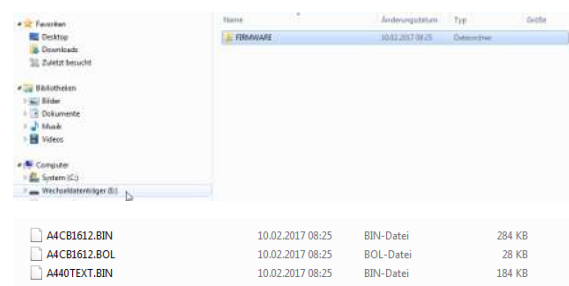

- ▶ Click on arrow for the hidden symbols.
  - Desktop bottom right.
  
- ▶ Click on USB connection symbol.
  - ⇒ Window with connected storage media appears.

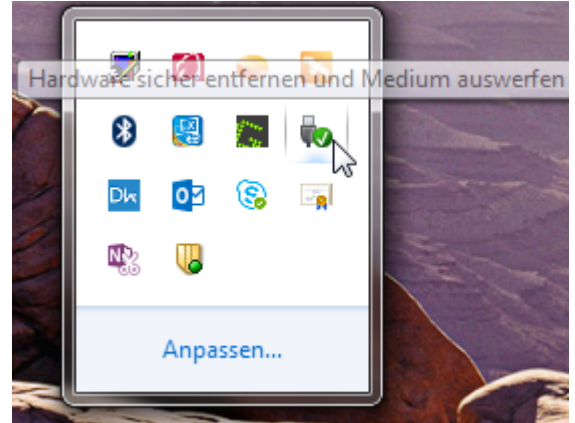

- ▶ Click on the storage media to be removed.
  - This process has successfully been completed when the window with the message «Hardware can now be removed» appears.
  - Software can be used to update the firmware on the AG440 according to user manual.

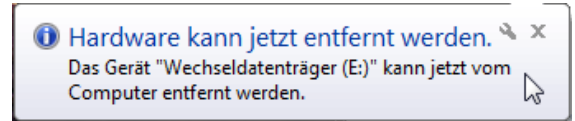

### 5.1.3 Updating software

These messages only appear on the left display.

- ▶ Update software.
- ▶ In the "Load firmware" menu, change the value to "Yes" with the UP/Down button.
- ▶ Confirm with the entry button.
  - ATTENTION: All user-specific settings will be lost! Save settings to a CF card beforehand.

The Please wait display message appears.

- From this point on the display messages are only in English.

Display is cleared.

Machine type AG440 and software version 1.05 appears.

Date, time and maximum power are displayed.

- ▶ Check information.
- Existing text files are deleted.

Message counts from 0%- 100% while new text file is installed.

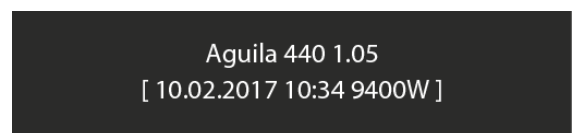
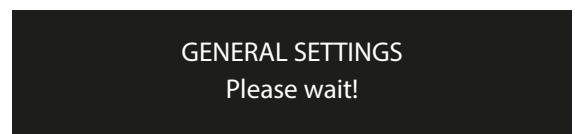
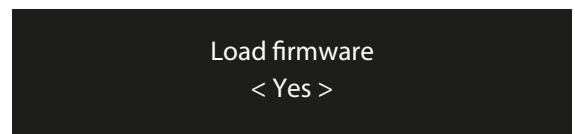

Fonts are installed.

General settings menu item is displayed.

- ▶ Proceed as described in the user manual.

Text will vary depending on the set language.

- ▶ Restore previously saved customer configuration.
  - ATTENTION: All current settings will be overwritten!
- ▶ Insert CF card with the saved data into the card slot on the CPU-Print.
- ▶ In the "Load configuration" menu, change the value to "Yes" with the UP/Down button.
- ▶ Confirm with the entry button.
  - ⇒ After a few seconds, the coffee machine switches back to the previous menu.
  - ⇒ Data was copied to the coffee machine.
- ▶ Remove CF card from the card slot.
- ▶ Exit service menu.
- ▶ Remove programming key.



TECHNICIAN MENU  
< GENERAL SETTINGS >

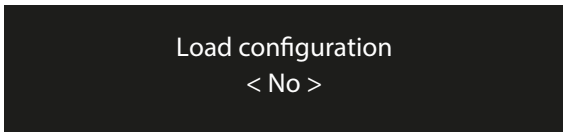

Load configuration  
< No >

## 5.2 STATISTICS

Under "STATISTICS" the counters of the individual products can be queried or reset.

- ▶ Query user counters of the individual products.

STATISTICS  
User product counter

- ▶ Press product.  
⇒ Counter is displayed.

User product counter  
< Choose a product >

- Displays the total prepared capsule products.

STATISTICS  
Capsulecounter user =

- ▶ Reset user counter to 0.
- ▶ Change the value to "Yes" with the Up/Down button.
- ▶ Confirm with the entry button.
- ▶ Query service counters of the individual products.

STATISTICS  
User counter reset

- ▶ Press product.  
⇒ Counter is displayed.

STATISTICS  
< Service product counter >

Service product counter  
< Choose a product >

- ▶ Reset service counter to 0.
  - This must be done after the service has been carried out so that the "Service required" message can be reset.
- ▶ Change the value to "Yes" with the Up/Down button.
- ▶ Confirm with the entry button.
- Displays the total number of all prepared products.

STATISTICS  
Service counter reset

- Displays total number of all prepared capsule products.

STATISTICS  
Capsule products counter =

- ▶ The total amount of water (in litres) that has flowed through the coffee machine is read.

STATISTICS  
Water counter = x l

- ▶ Reset water counter to 0.
- ▶ Change water filter.
- ▶ Confirm change.
- ▶ Reset "Change water filter" message.
- ▶ Change the value to "Yes" with the Up/Down button.
- ▶ Confirm with the entry button.
- Displays the total number of all operations carried out.

STATISTICS  
Water counter reset

- Displays the total number of all cleaning operations cancelled.

STATISTICS  
Cleaning counter = x

- Displays the total number of all prepared products from brewing unit 1

STATISTICS  
Brewing unit 1 = x

- Displays the total number of all prepared products from brewing unit 2

STATISTICS  
Brewing unit 2 = x

- Displays the total number of all prepared products from brewing unit 3

STATISTICS  
Brewing unit 3 = x

- Displays the total number of all prepared products from brewing unit 4

STATISTICS  
Brewing unit 4 = x

- Reset statistics of brewing unit 1.
- ▶ Change the value to "Yes" with the Up/Down button.

STATISTICS  
Brewing unit 1 reset = No

- ▶ Confirm with the entry button.
- Reset statistics of brewing unit 2.
- ▶ Change the value to "Yes" with the Up/Down button.

STATISTICS  
Brewing unit 2 reset = No

- ▶ Confirm with the entry button.
- Reset statistics of brewing unit 3.
- ▶ Change the value to "Yes" with the Up/Down button.

STATISTICS  
Brewing unit 3 reset = No

- ▶ Confirm with the entry button.
- Reset statistics of brewing unit 4.
- ▶ Change the value to "Yes" with the Up/Down button.

STATISTICS  
Brewing unit 4 reset = No

- ▶ Confirm with the entry button.

## 5.3 MACHINE PARAMETERS

In this menu, you can perform basic settings on the coffee machine, such as the service interval time when the water filter must be changed.

- ▶ Enter the number of litres, which correspond to the water filter used.

Filter change max = 8000 l  
[ 0 .. < 8000 l > .. 20000 ]

- If the counted water quantity (in litres) has reached the entered value, the "Change water filter" message appears on the display.

- ▶ Change water filter.

- ▶ In the "STATISTICS" menu, reset the water quantity (see menu item "Reset water quantity" STATISTICS).

- ▶ Enter the maximum number of products that can be prepared until the "Service required" message appears on the display.

Product counter max. = 48 x 1000  
[ 10 .. < 48 x1000 > .. 100 ]

- ▶ Set service interval time (in months).

- If the device has reached the selected time, the "Service required" message appears on the display.

Service interval = 12 m  
[ 3 .. < 12 m > .. 24 ]

- Displays the total output (in Watt) of the coffee machine.

Supply power = 3000 W  
[ 2500 .. < 3000 W > .. 9400 ]

- Indicates the capacity of the collecting container for used capsules.

- If the set number of capsules is reached, the "Empty grounds drawer!" message appears on the display.

Drawer capacity = 130  
[ 0 .. < 130 pads > .. 300 ]

- "Empty grounds drawer!" message is displayed.

- ▶ Empty the grounds drawer and keep it outside of the coffee machine for the set number of seconds.

Drawer reset time = 5 s  
[ 5 .. < 5 s > .. 10 ]

⇒ Message is reset.

- ▶ Set cup heater.

- ▶ "On": Cup heater of the coffee machine is activated.

Cup heater = On  
< On >

- ▶ "Off": Cup heater of the coffee machine is deactivated.

- ▶ Set heating interval of the cup heater in 5% steps.

- The duration in which the heater is actively set is in percent, since the heater is switched on and off in intervals.

Cupheater power = 75 %  
[ 0 .. < 75 % > .. 100 ]

## 5.4 ENERGY SAVING MODE

In this menu, you can adjust the energy saving modes of the device.

- ▶ After the set time has elapsed, the coffee machine changes to standby mode 1:
  - ⇒ The boiler cool down to 60 °C.
- ▶ Press any button to heat up the coffee machine again.
  - ⇒ Coffee machine is ready for operation again within one minute.
- ▶ After the set time has elapsed, the coffee machine changes to standby mode 2:
  - ⇒ Heaters are switched off.
  - ⇒ Refrigerator is still in operation.
- ▶ Press energy standby button to start up the coffee machine again.
- ▶ Select "On" value to switch the coffee machine to standby mode 2 immediately after cleaning.

Energysave for mode 1 = 30 min  
[ 0 .. < 30 min > .. 60 ]

Energysave for mode 2 = 240 min  
[ 0 .. < 240 min > .. 720 ]

Enter after cleaning = On  
< On >

## 5.5 MILK SETTINGS

In the "MILK SETTINGS" menu the rotation speeds for milk and milk foam as well as the refrigerator temperature can be adjusted.

- ▶ Set the rotation speed of the milk pump for preparing milk.
- ▶ Set the rotation speed of the milk pump for preparing milk.
- ▶ Set the rotation speed of the milk pump for preparing milk.

MILK PARAMETERS  
Milk pump rpm = 700 rpm

Milk pump rpm = 700 rpm  
[ 600 .. < 700 rpm > .. 1000 ]

MILK PARAMETERS  
Foam pump rpm left = 1900 rpm

Foam pump rpm left = 1900 rpm

MILK PARAMETERS  
Foam pump rpm right = 1900 rpm

Foam pump rpm right = 1900 rpm

MILK PARAMETERS  
Cooling temperature = 5.0 °C

- ▶ Enter value that determines the temperature inside the refrigerator.

Refrigerator temp. = 5.0 °C  
[ 4.0 .. < 5.0 °C > .. 8.0 ]

MILK PARAMETERS  
Hot foam left = 0.0 %

- ▶ Percentage of air content for user level.
  - ⇒ A lower value results in more fluid foam.
  - ⇒ A higher value results in more solid foam.
- The foam setting can be adjusted differently on the right and left.
- The full adjustment possibility of the hot milk foam from 0 to 100 % is described in the menu Products.

Hot foam left = 0.0 %  
[ -10.0 .. < 0.0 % > .. 10.0 ]

MILK PARAMETERS  
Hot foam right = 0.0 %

Hot foam right = 0.0 %  
[ -10.0 .. < 0.0 % > .. 10.0 ]

MILK PARAMETERS  
Cold foam left = 0.0 %

Cold foam left = 0.0 %  
[ -10.0 .. < 0.0 % > .. 10.0 ]

MILK PARAMETERS  
Cold foam right = 0.0 %

Cold foam right = 0.0 %  
[ -10.0 .. < 0.0 % > .. 10.0 ]

## 5.6 COFFEE BOILER

In this menu the temperature of the water can be set in the coffee boilers.

- ▶ Enter water temperature of the coffee products on the left module.

COFFEE BOILER  
Set temperature left = 92 °C

Nom. temperature left = 92 °C  
[ 60 .. < 92 °C > .. 95 ]

COFFEE BOILER  
Set temperature right = 92 °C

- ▶ Enter water temperature of the coffee products on the right module.

Nom. temperature right = 92 °C  
[ 60 .. < 92 °C > .. 95 ]

COFFEE BOILER  
Temp. tolerance = 5 °C

- ▶ Enter value specifying from when coffee products can be prepared.
  - As soon as the coffee boiler has reached the tolerance value setpoint temperature minus, the machine for preparing coffee products is ready.

Temp. tolerance = 5 °C  
[ 0 .. < 5 °C > .. 8 ]

## 5.7 TEA/MILK BOILER

In this menu the temperature of the water can be set in the tea/coffee boilers.

TEA/MILK BOILER  
Set temperature left = 80 °C

- ▶ Enter water temperature in the tea/milk boiler on the left module.

Nom. temperature left = 80 °C  
[ 75 .. < 80 °C > .. 85 ]

TEA/MILK BOILER  
Set temperature right = 80 °C

- ▶ Enter water temperature in the tea/milk boiler on the right module.

Nom. temperature right = 80 °C  
[ 75 .. < 80 °C > .. 85 ]

TEA/MILK BOILER  
Temp. tolerance = 5 °C

- ▶ Enter value specifying from when tea and milk products can be prepared.
  - As soon as the boiler has reached the tolerance value "setpoint temperature" minus, the machine for preparing milk products is ready.

Temp. tolerance = 5 °C  
[ 0 .. < 5 °C > .. 8 ]

## 5.8 CLEANING PARAMETERS

In this menu the blocking time can be set. The blocking time defines the period after preparing the first milk product until the blocking of the machine in order to force a cleaning operation. For reasons of hygiene, the coffee machine must be cleaned at least once within 24 hours as soon as a milk product has been prepared.

CLEANING PARAMETERS  
Locktime = 24 h

- ▶ Specify how many hours can elapse after preparing the first milk product until the coffee machine is blocked in order to carry out cleaning.

Lock time = 24 h  
[ 0 .. < 24 h > .. 24 ]

## 5.9 OUTPUT TEST

In this menu the functionality of all electrical components in the machine can be tested.

- ▶ Press input button.
  - ⇒ Water inlet valve is closed.
- If a "click" sound can be heard when releasing the button, the valve works.

OUTPUT TEST LEFT  
Water Inlet Valve

- ▶ Press input button.
  - ⇒ Brewing chamber valve 1 is opened.
- If the brewing chamber is closed, a "click" sound should be heard.

OUTPUT TEST LEFT / RIGHT  
Chamber Release Valve 1

- ▶ Press input button.
  - ⇒ Brewing chamber valve 2 is opened.
- If the brewing chamber is closed, a "click" sound should be heard.

OUTPUT TEST LEFT / RIGHT  
Chamber Release Valve 2

- ▶ Press input button.
  - ⇒ Brewing valve 1 is opened.
- If the brewing chamber is closed, a "click" sound should be heard.

OUTPUT TEST LEFT / RIGHT  
Brew Valve 1

- ▶ Press input button.
  - ⇒ Brewing valve 2 is opened.
- If the brewing chamber is closed, a "click" sound should be heard.

OUTPUT TEST LEFT / RIGHT  
Brew Valve 2

- ▶ Press input button.
  - ⇒ Tea valve on the boiler is opened.
- If a "click" sound can be heard, the valve works.

OUTPUT TEST LEFT / RIGHT  
Tea Valve 1

- ▶ Press input button.
  - ⇒ Tea valve 2 (on the machine module chassis at the front) is opened.
- If a "click" sound can be heard, the valve works.

OUTPUT TEST LEFT / RIGHT  
Tea Valve 2

- ▶ Press input button.
  - ⇒ Venting valve is opened.
- If a "click" sound can be heard, the valve works.

OUTPUT TEST LEFT / RIGHT  
Exhaust Valve

- ▶ Press input button.
  - ⇒ Milk cleaning valve is opened.
- If a "click" sound can be heard, the valve works.

OUTPUT TEST LEFT / RIGHT  
Milk Clean Valve

- ▶ Press input button.
  - ⇒ Milk rinsing valve is opened.
- If a "click" sound can be heard, the valve works.

OUTPUT TEST LEFT / RIGHT  
Milk Rinse Valve

- ▶ Press input button.
  - ⇒ Cold milk valve is opened.
- If a "click" sound can be heard, the valve works.

OUTPUT TEST LEFT / RIGHT  
Cold Milk Valve

- ▶ Press input button.
  - ⇒ Milk discharge valve is opened.
- If a "click" sound can be heard, the valve works.

OUTPUT TEST LEFT / RIGHT  
Milk Outlet Valve

- ▶ Press input button.
- ▶ Milk outlet valve is opened.
- If a "click" sound can be heard, the valve works.

OUTPUT TEST LEFT / RIGHT  
Milk Drain Valve

- ▶ Press input button.
  - ⇒ Milk air valve is opened.

OUTPUT TEST LEFT / RIGHT  
Milk Air Valve

- ▶ Press input button.
  - ⇒ Cleaning tablet valve is opened.
- If a "click" sound can be heard, the valve works.

OUTPUT TEST LEFT / RIGHT  
Cleaning Tablet Valve

- ▶ Press and hold down the input button to test the water pump.
  - ⇒ The LED "LD2" illuminates on the Power PCB.
  - ⇒ If the pump in the output test left is activated, water comes out of the left tea outlet. If the pump in the output test right is activated, water comes out of the right tea outlet.

OUTPUT TEST LEFT / RIGHT  
Water Pump

- ▶ Press and hold down the input button to test the milk pump.
  - ⇒ Fresh water runs through the pump/milk outlet.
- ▶ Start internal rinsing sequence by briefly pressing the input button (5 min).

OUTPUT TEST LEFT / RIGHT  
Milk Pump

- ▶ Press and hold down the input button to test the fan in the refrigerator.

OUTPUT TEST RIGHT  
Refrigerator fan

- Displays the current temperature of coffee boiler 1.
- ▶ Press input button.
  - ⇒ Boiler heater is switched on.
  - ⇒ The LED "LD5" illuminates on the Power PCB.

OUTPUT TEST LEFT / RIGHT  
Coffee boiler 1 = xx.x °C

- ATTENTION: The controller is not active, the boiler could overheat!
- Displays the current temperature of coffee boiler 2.
- ▶ Press input button.
  - ⇒ Boiler heater is switched on.
  - ⇒ The LED "LD6" illuminates on the Power PCB.

OUTPUT TEST LEFT / RIGHT  
Coffee boiler 2 = xx.x °C

- ATTENTION: The controller is not active, the boiler could overheat!
- Displays the current temperature of the tea/milk boiler.

OUTPUT TEST LEFT / RIGHT  
Tea/Milk boiler = xx.x °C

- ▶ Press input button.
  - ⇒ Boiler heater is switched on.
  - ⇒ The LED "LD4" illuminates on the Power PCB.
- ATTENTION: The controller is not active, the boiler could overheat!
- ▶ Press input button to switch on the cup heater.
- ▶ Check cup heater on the Power PCB by means of the LED.
  - ⇒ The LED "LD1" illuminates on the Power PCB.

OUTPUT TEST LEFT / RIGHT  
Cup Heater

## 5.10 INPUT TEST

In this menu the functionality of all inputs (sensors) in the machine can be tested.

- Displays the current status of the grounds drawer.

INPUT TEST LEFT / RIGHT  
Drawer = Open

- Displays the current status of the cleaning key.
- "closed" Cleaning key present and inserted/locked correctly.
- "open": Cleaning key not present.

INPUT TEST LEFT  
Cleaning key = closed

- Displays whether a cleaning tablet is in the cleaning key.
- "No": No tablet is present in the key (reed switch closed).
- "Yes": Tablet is present in the key (reed switch open).

INPUT TEST LEFT  
Cleaning tablet = No

- Displays the current status of brewing chamber 1.
- "open": Brewing chamber is opened (microswitch is open).
- "closed": Brewing chamber is closed (microswitch is pressed).

INPUT TEST LEFT / RIGHT  
Brew Chamber 1 = open

- Displays the current status of brewing chamber 2.
- "open": Brewing chamber is opened (microswitch is open).
- "closed": Brewing chamber is closed (microswitch is pressed).

INPUT TEST LEFT / RIGHT  
Brew Chamber 2 = open

- Displays the current temperature of coffee boiler 1.
- If a temperature of 3276.8 °C is displayed, either a cable break or short-circuit at the NTC has occurred.

INPUT TEST LEFT / RIGHT  
NTC Boiler 1 = xx.x °C

- Displays the current temperature of coffee boiler 2.
- If a temperature of 3276.8 °C is displayed, either a cable break or short-circuit at the NTC has occurred.

INPUT TEST LEFT / RIGHT  
NTC Boiler 2 = xx.x °C

- Displays the current temperature of the tea/milk boiler.
- If a temperature of 3276.8 °C is displayed, either a cable break or short-circuit at the NTC has occurred.

INPUT TEST LEFT / RIGHT  
NTC Boiler 3 = xx.x °C

- Displays the current temperature inside the refrigerator.
- If a temperature of 3276.8 °C is displayed, either a cable break or short-circuit at the NTC has occurred.

INPUT TEST LEFT  
NTC Refrigerator = x.x °C

- Displays the impulses of flowmeter 1.
- ▶ Press and hold down the input button to test the flowmeter.
  - ⇒ The number of ticks is displayed (brewing chamber must be closed).

INPUT TEST LEFT / RIGHT  
Flowmeter 1 = x ticks

- Displays the impulses of flowmeter 2.
- ▶ Press and hold down the input button to test the flowmeter.
  - ⇒ The number of ticks is displayed (brewing chamber must be closed).

INPUT TEST LEFT / RIGHT  
Flowmeter 2 = x ticks

- Displays the current milk temperature in the refrigerator.
- If the temperature is above 12 °C, the preparation of milk products is blocked.

INPUT TEST LEFT / RIGHT  
Milk temperature = x.x °C

- If a temperature of 3276.8 °C is displayed, either a cable break or short-circuit at the NTC has occurred.
- Displays the status of the upper milk level sensor.
- "Off": "Milk level low" not reached (continuity exists), there is still sufficient milk in the container.
- "On": "Milk level low" reached, milk level is below the sensor (no continuity), milk almost empty.
- Displays the status of the lower milk level sensor.
- "Off": "there is still milk in the container (continuity exists).
- "On": Milk level is below the sensor (no continuity), there is no more milk left.
- Displays the current status of the energy standby button.
- ▶ Press energy standby button.
  - ⇒ Display changes to "On".
- "Off": Button is not pressed, standby mode is not activated.
- "On": Button is pressed, standby mode is activated.

INPUT TEST LEFT / RIGHT  
Milk Level Low = Off

INPUT TEST LEFT / RIGHT  
Milk Container Empty = Off

INPUT TEST LEFT  
Energy Save Button = Off

## 5.11 Products

In this menu you can change all parameters of the individual products and adapt your own preferences.

Note: Not all parameters are available for all products, thus, for example "milk time" can only be set for products with milk or "hot water" can only be set for a tea product".

### Learn Mode

The Aguila coffee machine provides a learn mode in order to set the required preparation quantity for a product very easily. To do this, the product is prepared while the respective parameter is selected in the menu. The prepared quantity is saved and not value needs to be entered.

- ▶ Select product.
- ▶ Select parameters.
- ▶ Press and hold down the product button until the product preparation starts.
- ▶ Press the product button again as soon as the required quantity is reached.
  - ⇒ The preparation stops and the quantity is saved.

Note: The learn mode is only available with the parameters marked with "Learn mode".

- ▶ Press the product whose settings you want to changed.
- ▶ Change coffee quantity (in ticks).
  - Learn Mode

PRODUCTS  
< Choose a product >

Coffee ticks = x  
[ 0 .. < x > .. 900 ]

- ▶ The set value (in sec) determines how long hot water is output.
  - Learn Mode
- ▶ The set value (in sec) determines how long milk is added to the product.
  - Learn Mode
- The set value (in sec) determines how long foam is added to the product.
  - Learn Mode
- ▶ Adjust the foam quality during preparation.
- ▶ While preparing the foam time with the "Up" and "Down" button, increase or decrease the air supply until the desired foam quality is reached.
- ▶ Adjust pre-brewing time (in sec).
- ▶ Adjust idle time (in sec).
- ▶ Delay (in sec) the dispensing of coffee (necessary e.g. for Macchiato products so that the milk foam can set in the cup).
- ▶ Select when milk/foam should be added to the product:
  - ⇒ At the beginning: milk/foam is dispensed before coffee.
  - ⇒ During: Milk/foam is dispensed simultaneously with coffee.
  - ⇒ At the end: Milk/foam is dispensed after coffee.
- ▶ Select between hot or cold milk.
- ▶ Select between hot or cold milk foam.

Hot water = x.x s  
[ 0.0 .. < x.x s > .. 65.0 ]

Milk time = x.x s  
[ 0.0 .. < x.x s > .. 60.0 ]

Foam time = x.x s  
[ 0.0 .. < x.x s > .. 60.0 ]

Prebrew time = x.x s  
[ 0.0 .. < x.x s > .. 2.0 ]

Settling time = x.x s  
[ 0.0 .. < x.x s > .. 5.0 ]

Coffee delay = x s  
[ 0 .. < x s > .. 30 ]

Add milk = x  
< x >

Milk type = hot  
< hot >

Foam type = cold  
< cold >

MILK PARAMETERS  
Hot foam left = 0.0 %

- ▶ Adjust the percentage of air content required to change the fluidity of the hot milk foam.
  - ⇒ A lower value results in more fluid foam.
  - ⇒ A higher value results in more solid foam.
- The foam setting can be adjusted differently on the right and left.
- Full adjustment possibility of the hot milk foam from 0 to 100 %.

Hot foam left = x.x %  
[ 0.0 .. < x.x % > .. 100.0 ]

MILK PARAMETERS  
Hot foam right = 0.0 %

- ▶ Adjust the percentage of air content required to change the fluidity of the hot milk foam.
  - ⇒ A lower value results in more fluid foam.
  - ⇒ A higher value results in more solid foam.
- The foam setting can be adjusted differently on the right and left.
- Full adjustment possibility of the hot milk foam from 0 to 100 %.

Hot foam right = x.x %  
[ 0.0 .. < x.x % > .. 100.0 ]

MILK PARAMETERS  
Cold foam left = 0.0 %

- ▶ Adjust the percentage of air content required to change the fluidity of the cold milk foam.
  - ⇒ A lower value results in more fluid foam.
  - ⇒ A higher value results in more solid foam.
- The foam setting can be adjusted differently on the right and left.
- Full adjustment possibility of the cold milk foam from 0 to 100 %.

Cold foam left = x.x %  
[ 0.0 .. < x.x % > .. 100.0 ]

MILK PARAMETERS  
Cold foam right = 0.0 %

- ▶ Adjust the percentage of air content required to change the fluidity of the cold milk foam.
  - ⇒ A lower value results in more fluid foam.
  - ⇒ A higher value results in more solid foam.
- The foam setting can be adjusted differently on the right and left.
- Full adjustment possibility of the cold milk foam from 0 to 100 %.

Cold foam right = x.x %  
[ 0.0 .. < x.x % > .. 100.0 ]

## 5.12 ERROR TRACE

The error messages that occurred are logged. The different error messages can be reviewed with the Up/down button. There are 64 storage locations available. Upon reaching 64 error messages, the oldest error message is overwritten.

- ▶ Clear error trace.
- ▶ Change the value to "Yes" with the Up/Down button.
- ▶ Confirm with the entry button.
- ▶ Save error messages with time and date specification as well as with a brief description of the error.

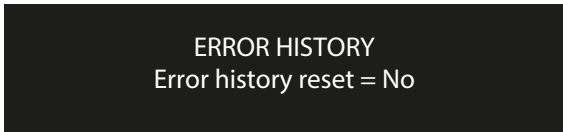

ERROR HISTORY  
Error history reset = No

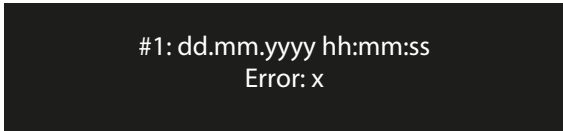

#1: dd.mm.yyyy hh:mm:ss  
Error: x







**thermoplan**  
Swiss Quality Coffee Equipment

Thermoplan AG  
Thermoplan-Platz 1  
6353 Weggis, Switzerland  
Tel. +41 41 392 12 00  
[thermoplan@thermoplan.ch](mailto:thermoplan@thermoplan.ch)  
[www.thermoplan.ch](http://www.thermoplan.ch)