



***Bandsaws***  
*Model BS-VE-3200-S, 3200-T*  
*Item 10272, 18943*  
***Instruction Manual***



*Revised - 02/05/2019*



Toll Free: 1-800-465-0234  
Fax: 905-607-0234  
Email: [service@omcan.com](mailto:service@omcan.com)  
[www.omcan.com](http://www.omcan.com)

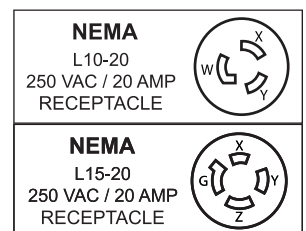

# ***Table of Contents***

Model BS-VE-3200-S / Model BS-VE-3200-T

---

<b>Section</b>	<b>Page</b>
General Information -----	3 - 4
Safety and Warranty -----	4 - 5
Technical Specifications -----	6
Installation -----	6
Operation -----	6 - 7
Maintenance -----	7 - 8
Parts Breakdown -----	9 - 17
Electrical Schematics -----	18 - 19
Notes -----	20 - 22
Warranty Registration -----	23



# General Information

---

Omcan Manufacturing and Distributing Company Inc., Food Machinery of America, Inc. dba Omcan and Omcan Inc. are not responsible for any harm or injury caused due to any person's improper or negligent use of this equipment. The product shall only be operated by someone over the age of 18, of sound mind, and not under the influence of any drugs or alcohol, who has been trained in the correct operation of this machine, and is wearing authorized, proper safety clothing. Any modification to the machine voids any warranty, and may cause harm to individuals using the machine or in the vicinity of the machine while in operation.

## CHECK PACKAGE UPON ARRIVAL

Upon receipt of an Omcan shipment please inspect for external damage. If no damage is evident on the external packaging, open carton to ensure all ordered items are within the box, and there is no concealed damage to the machine. If the package has suffered rough handling, bumps or damage (visible or concealed), please note it on the bill of lading before accepting the delivery and contact Omcan within 24 hours, so we may initiate a claim with the carrier. A detailed report on the extent of the damage caused to the machine must be filled out within three days, from the delivery date shown in the shipping documents. Omcan has no recourse for damaged products that were shipped collect or third party.

**Before operating any equipment, always read and familiarize yourself with all operation and safety instructions.**

Omcan would like to thank you for purchasing this machine. It's of the utmost importance to save these instructions for future reference. Also save the original box and packaging for shipping the equipment if servicing or returning of the machine is required.

---

Omcan Fabrication et distribution Compañie Limité et Food Machinery d'Amérique, dba Omcan et Omcan Inc. ne sont pas responsables de tout dommage ou blessure causé du fait que toute personne ait utilisé cet équipement de façon irrégulière. Le produit ne doit être exploité que par quelqu'un de plus de 18 ans, saine d'esprit, et pas sous l'influence d'une drogue ou d'alcool, qui a été formé pour utiliser cette machine correctement, et est vêtu de vêtements de sécurité approprié. Toute modification de la machine annule toute garantie, et peut causer un préjudice à des personnes utilisant la machine ou des personnes à proximité de la machine pendant son fonctionnement.

## VÉRIFIEZ LE COLIS DÈS RÉCEPTION

Dès réception d'une expédition d'Omcan veuillez inspecter pour dommages externes. Si aucun dommage n'est visible sur l'emballage externe, ouvrez le carton afin de s'assurer que tous les éléments commandés sont dans la boîte, et il n'y a aucun dommage dissimulé à la machine. Si le colis n'a subi aucune mauvaises manipulations, de bosses ou de dommages (visible ou cachée), notez-le sur le bond de livraison avant d'accepter la livraison et contactez Omcan dans les 24 heures qui suivent, pour que nous puissions engager une réclamation auprès du transporteur. Un rapport détaillé sur l'étendue des dommages causés à la machine doit être rempli dans un délai de trois jours, à compter de la date de livraison indiquée dans les documents d'expédition. Omcan n'a aucun droit de recours pour les produits endommagés qui ont été expédiés ou cueilli par un tiers transporteur.

# ***General Information***

---

**Avant d'utiliser n'importe quel équipement, toujours lire et vous familiariser avec toutes les opérations et les consignes de sécurité.**

**Omcan voudrais vous remercier d'avoir choisi cette machine. Il est primordial de conserver ces instructions pour une référence ultérieure. Également conservez la boîte originale et l'emballage pour l'expédition de l'équipement si l'entretien ou le retour de la machine est nécessaire.**

-----  
**Omcan Empresa De Fabricacion Y Distribucion Inc. Y Maquinaria De Alimentos De America, Inc. dba Omcan y Omcan Inc. no son responsables de ningun daño o perjuicio causado por cualquier persona inadecuada o el uso descuidado de este equipo. El producto solo podra ser operado por una persona mayor de 18 años, en su sano juicio y no bajo alguna influencia de droga o alcohol, y que este ha sido entrenado en el correcto funcionamiento de esta máquina, y ésta usando ropa apropiada y autorizada. Cualquier modificación a la máquina anula la garantía y puede causar daños a las personas usando la máquina mientras esta en el funcionamiento.**

## **REVISE EL PAQUETE A SU LLEGADA**

Tras la recepcion de un envio Omcan favor inspeccionar daños externos. Si no hay daños evidentes en el empaque exterior, Habra el carton para asegurarse que todos los articulos solicitados estén dentro de la caja y no encuentre daños ocultos en la máquina. Si el paquete ha sufrido un manejo de poco cuidado, golpes o daños (visible o oculto) por favor anote en la factura antes de aceptar la entrega y contacte Omcan dentro de las 24 horas, de modo que podamos iniciar una reclamación con la compañía. Un informe detallado sobre los daños causados a la máquina debe ser llenado en el plazo de tres días, desde la fecha de entrega que se muestra en los documentos de envío. Omcan no tiene ningun recurso por productos dañados que se enviaron a recoger por terceros.

**Antes de utilizar cualquier equipo, siempre lea y familiarizarse con todas las instrucciones de funcionamiento y seguridad.**

**Omcan le gustaría darle las gracias por la compra de esta máquina. Es de la mayor importancia para salvar estas instrucciones para futuras consultas. Además, guarda la caja original y el embalaje para el envío del equipo si servicio técnico o devolución de la máquina que se requiere.**

# ***Safety and Warranty***

---

**CAUTION - NOT MEANT FOR FROZEN PRODUCT**

## **MAIN PRECAUTIONS**

When incorrectly used, a bandsaw can be a potentially dangerous machine. Cleaning, maintenance or service must always be done by experienced operators, and with the machine disconnected from the electricity supply.

# *Safety and Warranty*

---

- NEVER use tools not belonging to the machine to help operation.
- KEEP hands off the moving parts of the machine.
- NEVER connect the power source with wet hands or wet clothes.
- ALWAYS ground the machine properly.
- NEVER touch the blade even when it is not in use because its edge is very sharp, it can cause serious cuttings.
- NEVER adjust the cutting regulator (optional) with the blade in motion.
- NEVER use clothes with loosen sleeves specially near the wrist during the cutting operation.
- USE steel gloves during the cutting operation.
- NEVER switch on the machine with one of its doors opened.
- NEVER spray water or other liquid substances directly at motor, power switch or any other electrical components.
- KEEP your working area clean and dry to prevent it from becoming slippery.
- ALWAYS install equipment in working area with adequate light and space away from CHILDREN and visitors.
- NEVER operate without all warning labels attached and owner/operator manual available to operator.
- NEVER leave unattended while operating.
- STOP the machine immediately if you hear abnormal noises, of fear that injuries may occur.
- CONTACT your Distributor if you have any problems with the installation and operation of this machine.

## **1 YEAR PARTS AND LABOUR WARRANTY**

**Within the warranty period, contact Omcan Inc. at 1-800-465-0234 to schedule an Omcan authorized service technician to repair the equipment locally.**

**Unauthorized maintenance will void the warranty. Warranty covers electrical and part failures, not improper use.**

**Please see <https://omcan.com/disclaimer> for complete info.**

### **WARNING:**

The packaging components are classified as normal solid urban waste and can therefore be disposed of without difficulty.

**In any case, for suitable recycling, we suggest disposing of the products separately (differentiated waste) according to the current norms.**

**DO NOT DISCARD ANY PACKAGING MATERIALS IN THE ENVIRONMENT!**

# Technical Specifications

Model	BS-VE-3200-S	BS-VE-3200-T
Power	3 HP / 2.24 kW	
Blade Length	126" / 3200mm	
Blade Saw Dimensions	0.8" x 12.6" / 20 x 320mm	
Cutting Capacity	15" x 18" / 381 x 457mm	
Electrical	220V / 60 Hz / 1 Ph	220V / 60 Hz / 3 Ph
Amps	11A	9A
Weight	374 lbs. / 170 kgs.	
Packaging Weight	415 lbs. / 188 kgs.	
Packaging Dimensions	40" x 54" x 96" / 1016 x 1372 x 2438mm	
Item Number	10272	18943

## Installation

Be sure to install the bandsaw in an easily accessible area with plenty of space.

Grounding wire must always be connected.

**IMPORTANT: Check the tension of the blade by turning the handle clockwise before operating it.**

## Operation

### BEFORE OPERATION

Check and make sure the machine is in a stable location. Wash with warm water and soap all the food-contact parts, and wipe dry. To do it proceed as follows:

1. Switch the machine off and disconnect it from the power source.
2. Open the upper door and lower door by pulling the handle.
3. Loosen the blade turning the handle or calibrator (optional) clockwise and take it out from the upper and lower wheels.
4. Take out the staples which are in front of the upper and lower wheels to be able to pull them out.
5. Assemble the components following the inverse steps.

**IMPORTANT: The blade must be well calibrated. Use the handle turning it clockwise to get the right tension of the blade. Keep the machine off to adjust the cutting regulator.**

## OPERATION

Switch on the machine pressing the on/off switch.

Put the product to be processed onto the table, pushing it to the direction of the blade lined up by the cutting regulator (optional), maintaining the thickness of the slice desired.

When pulling back the product do not touch the blade avoiding disconnecting it from the wheels.

Drop a little bit of water onto the fixed table to facilitate the slipping of the product.

## Maintenance

---

### COMPONENTS ADJUSTMENT

#### PULLEY BELT

- The belt must be firmly fixed to prevent it from skidding. Do not tighten it too much because it can wear out quickly.
- To have access to the belt remove the screws with a screwdriver from the inferior back lid and take it out.
- With a screw-wrench loosen the screws turning it counter-clockwise. To stretch out the belt you have to push the motor with the wood lever tightening the screws.

**IMPORTANT: The pulleys must be lined up.**

#### UPPER BEARING ADJUSTMENTS

- The purpose of this adjustment is to centralize the blade on the gear and avoid it falling down.
- First of all disconnect the machine from the electricity supply. Then loosen blade turning handle counter-clockwise.
- Take out upper back lid by removing screws using the screwdriver. Loosen the three screw-nuts using a 10mm screw-wrench.
- Using the screwdriver turn the screw-nut  $\frac{1}{4}$  counter-clockwise if the wheel is inclined towards the front or turn it  $\frac{1}{4}$  clockwise if it is inclined backwards. Tighten the three screw-nut previously loosen. Calibrate the blade according to pre-operation.
- Turn the wheels manually to check if the blade is centralized, if it is not keep turning the wheels until the blade is centralized.

#### CUTTING REGULATOR

- The cutting regulator (optional) was designed to provide cuts with the same thickness and also to protect the operator from getting injured.
- To adjust the cutting regulator proceed as follows:  
Turn locking knob counter-clockwise to be able to move the cutting regulator to the left and right according to the distance you want to leave from it to the blade.
- Then turn the locking knob clockwise to fix the cutting regulator in the desired position.

# Maintenance

---

## CLEANING

First of all disconnect the machine from power source.

- Remove the upper door by unscrewing the screws of the hinges.
- Remove the lower door doing as above.
- Remove the blade by turning blade calibrator knob counter-clockwise, then loosen the blade and pull it out.
- Take out upper and lower wheels by pulling staples out, which are located in front of the wheels.
- Never use hard tools such as: knives, forks, hooks, or others to remove stuck pieces of cut meat from the upper and lower doors. To do that use a plastic brush.
- Assemble the components following the inverse steps.

**NOTE: The sharp edge of the blade must be facing the front of the machine.**

All removable components must be washed with warm water and neutral soap. Be careful when washing the blade. It has a sharp edge that could cause serious irreparable injuries to the hands.

**CAUTION: The machine is not protected against water jets. Do not clean it with steam jets, or high pressure blasts or similar methods. Under no circumstances should the bandsaw be hose rinsed as this may result in short circuit or serious damage to the machine.**

Clean the body of the machine with a damp clean cloth and wipe dry.

## REFERENCE

Item Number	Model Number	Description	Manufacturer Model Number
10272	BS-VE-3200-S	Band Saw 126" / 3200mm Blade 3 HP / 2237 W 220V/60/1 cETLus ETL Sanitation	B40
18943	BS-VE-3200-T	Band Saw 126" / 3200mm Blade 3 HP / 2237 W 220V/60/3 cETLus ETL Sanitation	B40-3PH

# Parts Breakdown

**Model BS-VE-3200-S** 10272

**Model BS-VE-3200-T** 18943

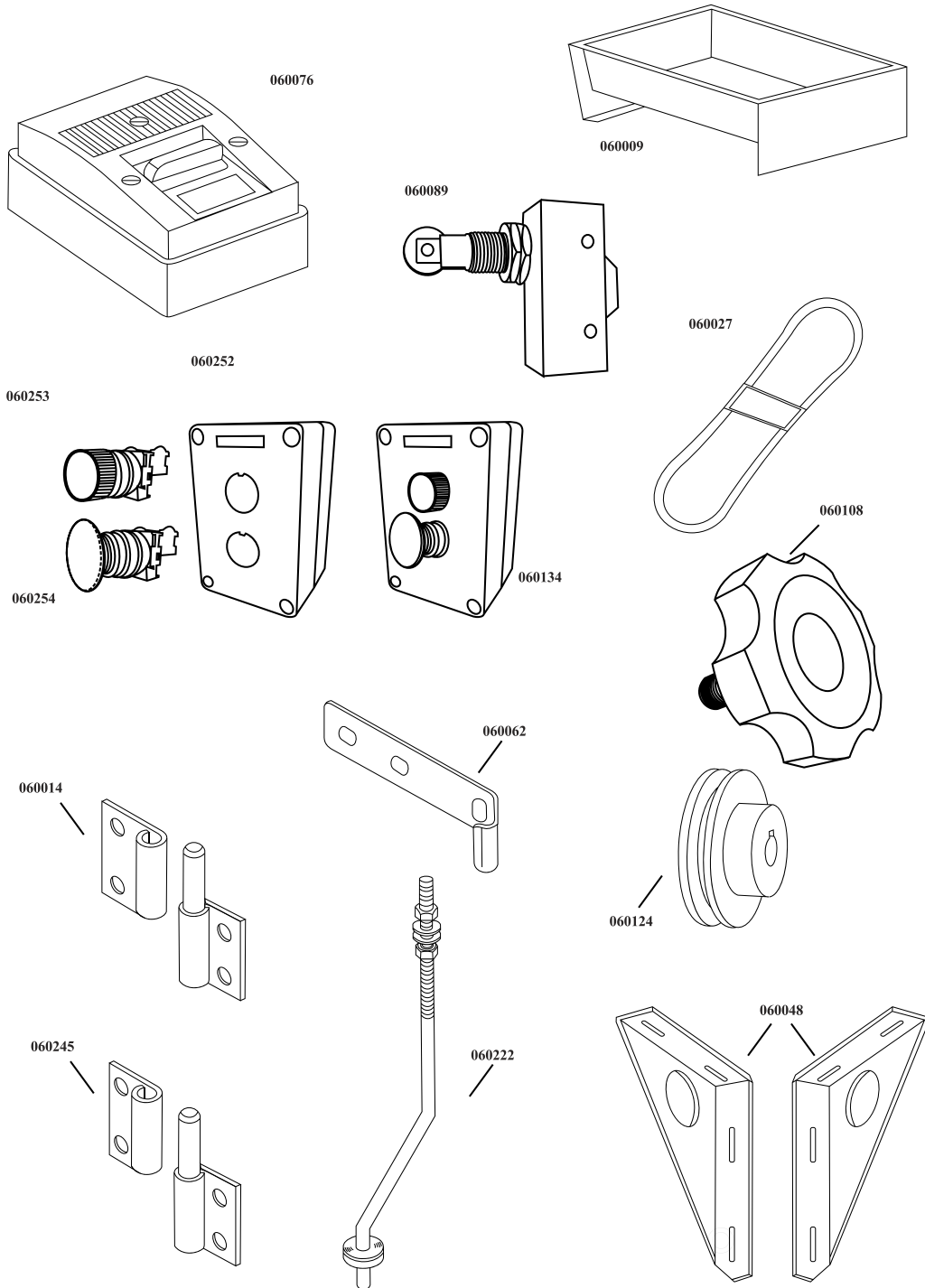

# Parts Breakdown

---

**Model BS-VE-3200-S** 10272

**Model BS-VE-3200-T** 18943

060098

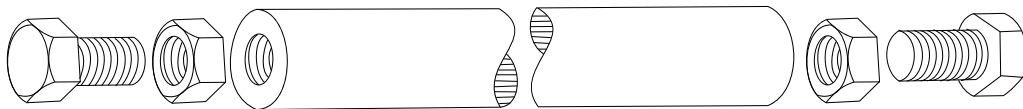
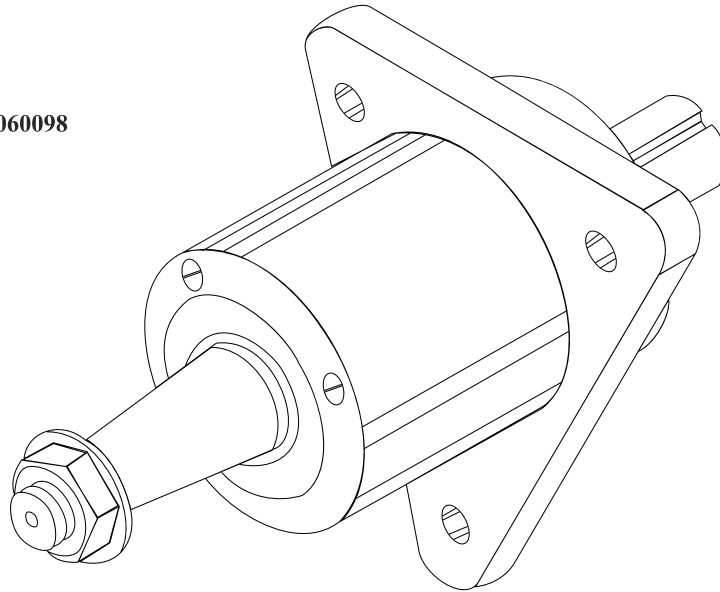

060035

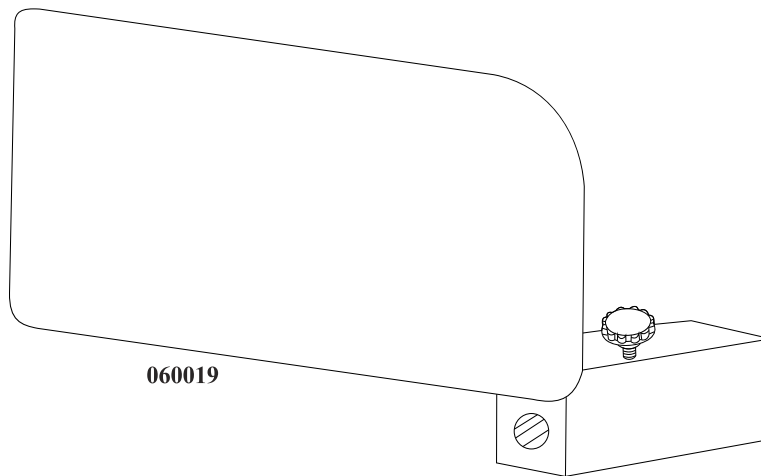

060019

# Parts Breakdown

**Model BS-VE-3200-S** 10272

**Model BS-VE-3200-T** 18943

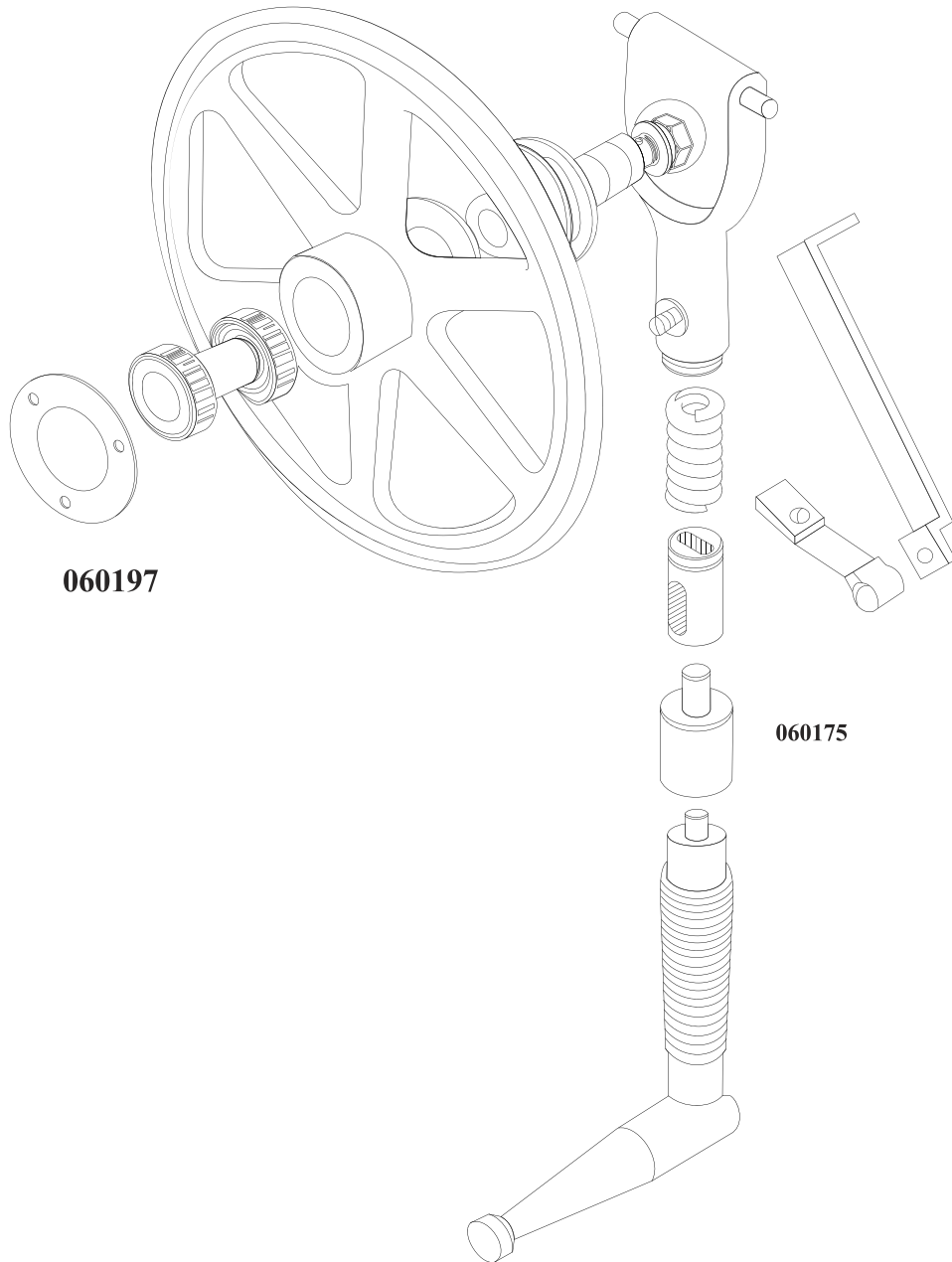

# Parts Breakdown

Model BS-VE-3200-S 10272

Model BS-VE-3200-T 18943

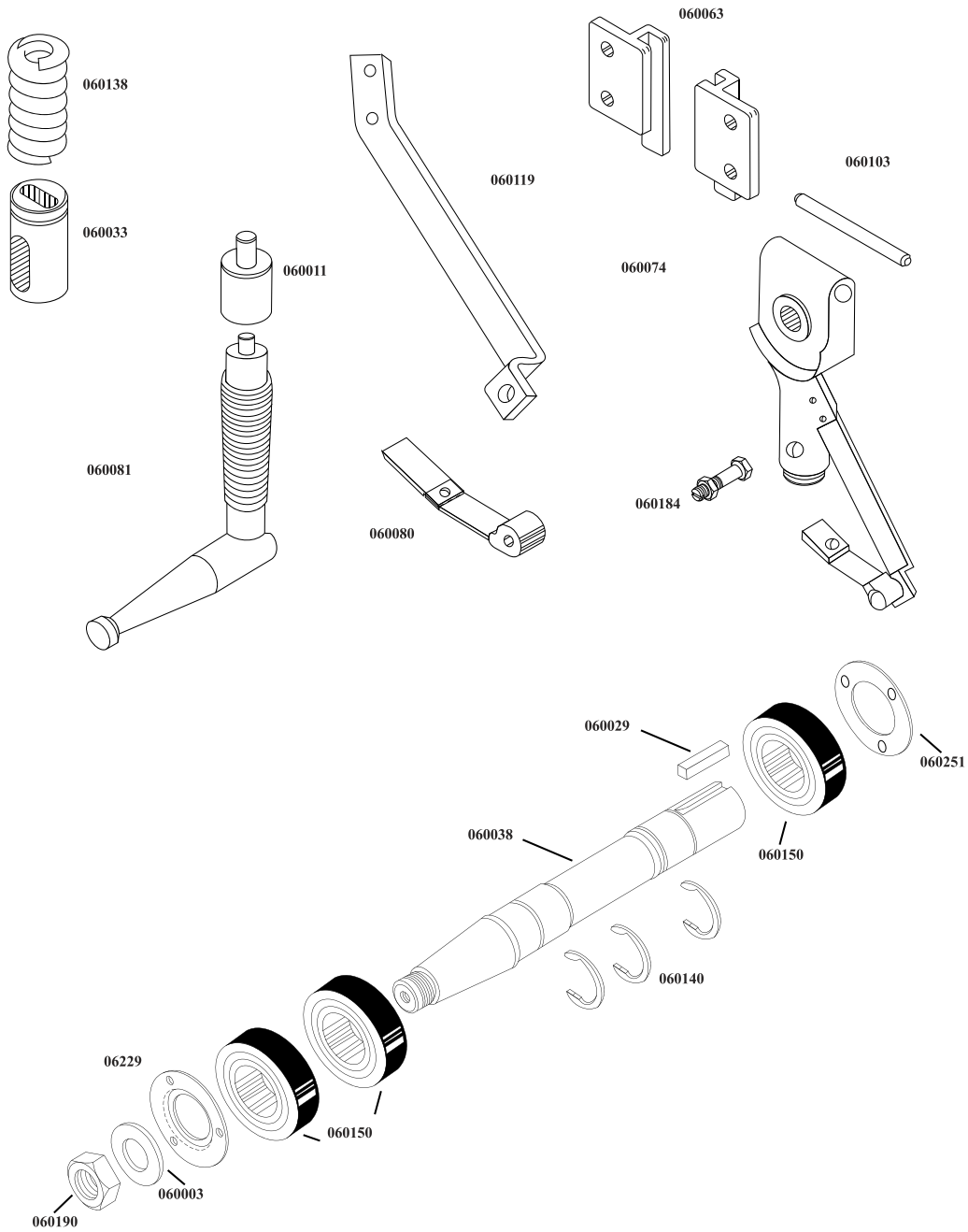

# Parts Breakdown

**Model BS-VE-3200-S** 10272

**Model BS-VE-3200-T** 18943

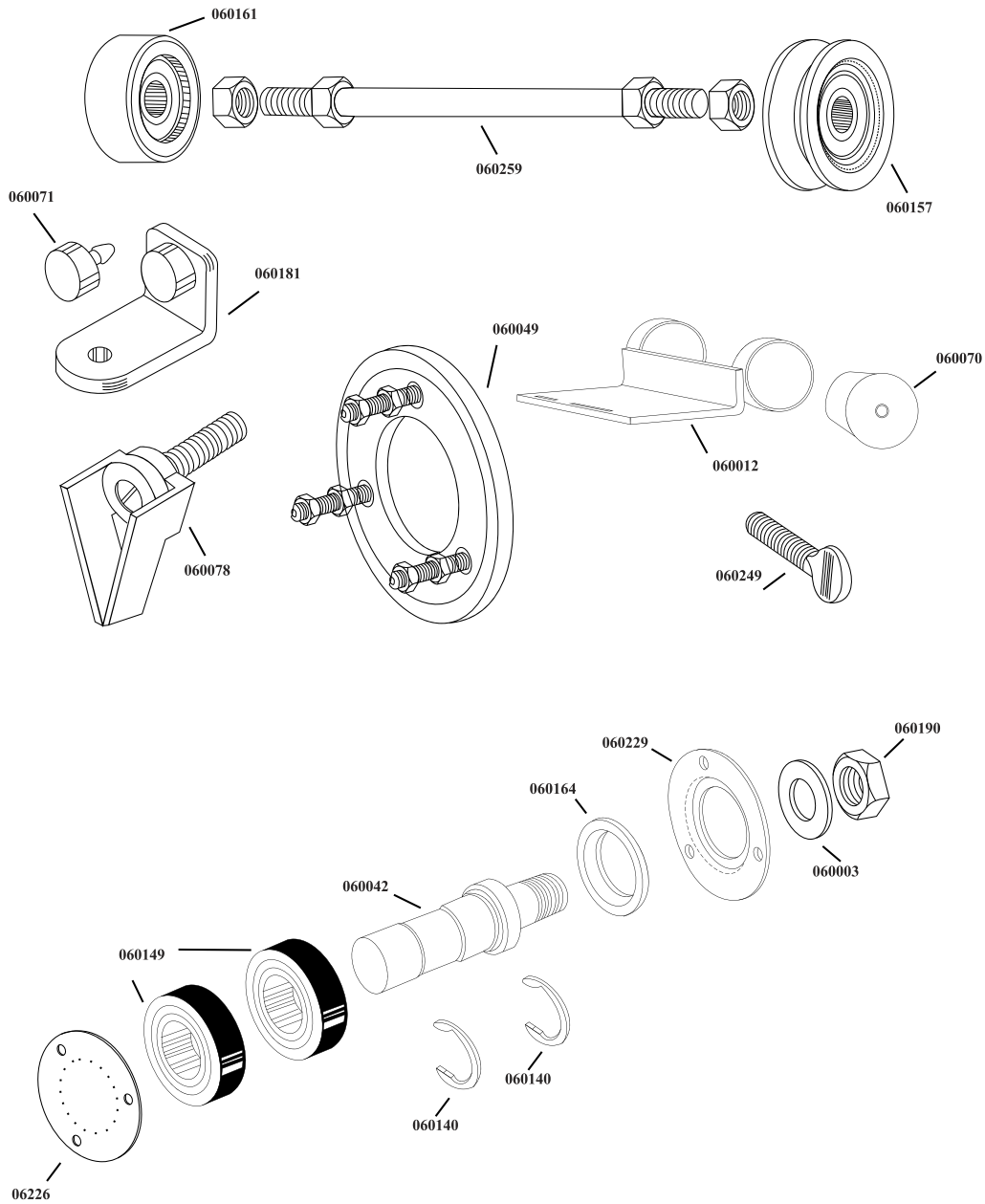

# Parts Breakdown

**Model BS-VE-3200-S** 10272

**Model BS-VE-3200-T** 18943

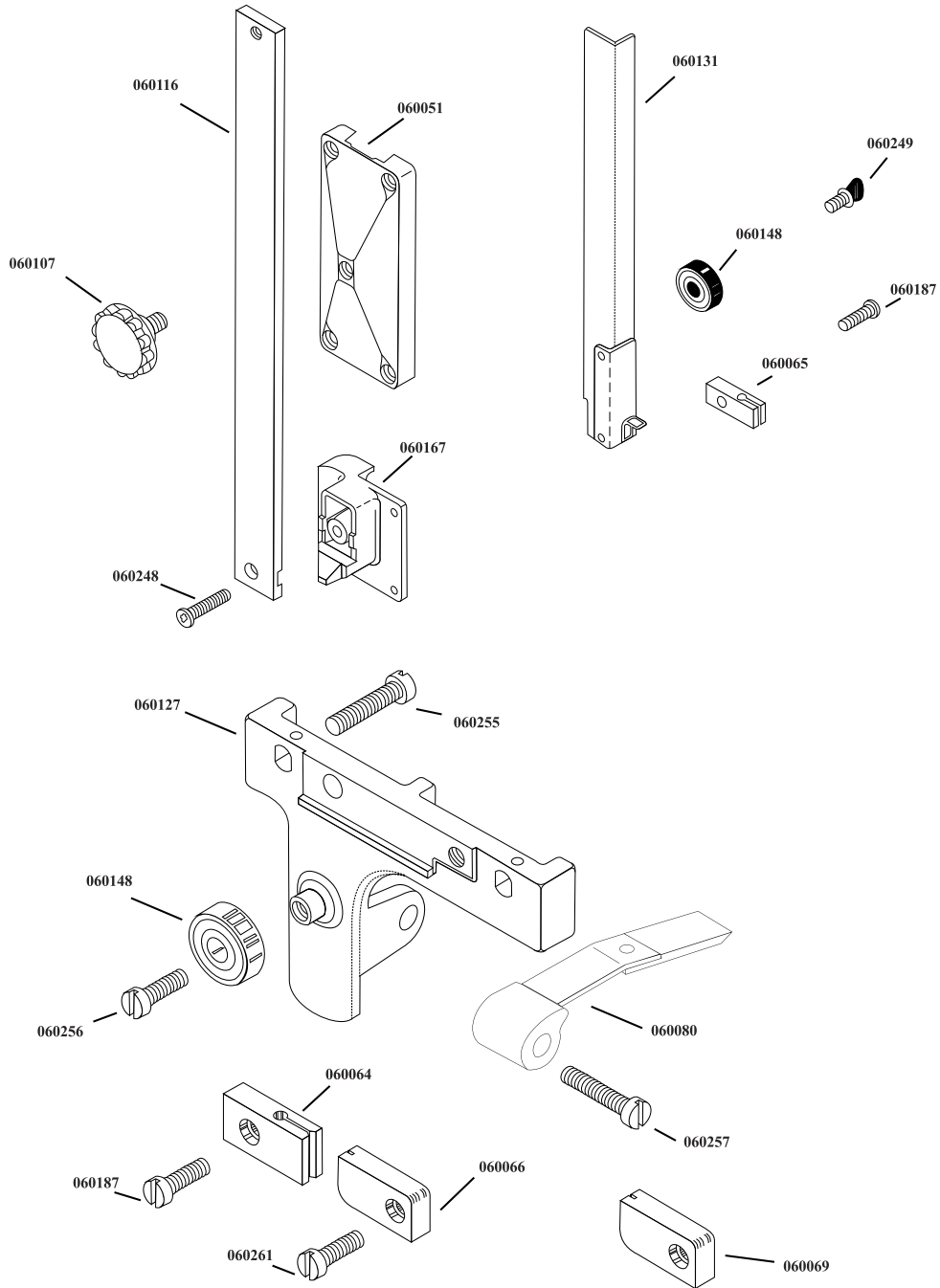

# Parts Breakdown

**Model BS-VE-3200-S** 10272

**Model BS-VE-3200-T** 18943

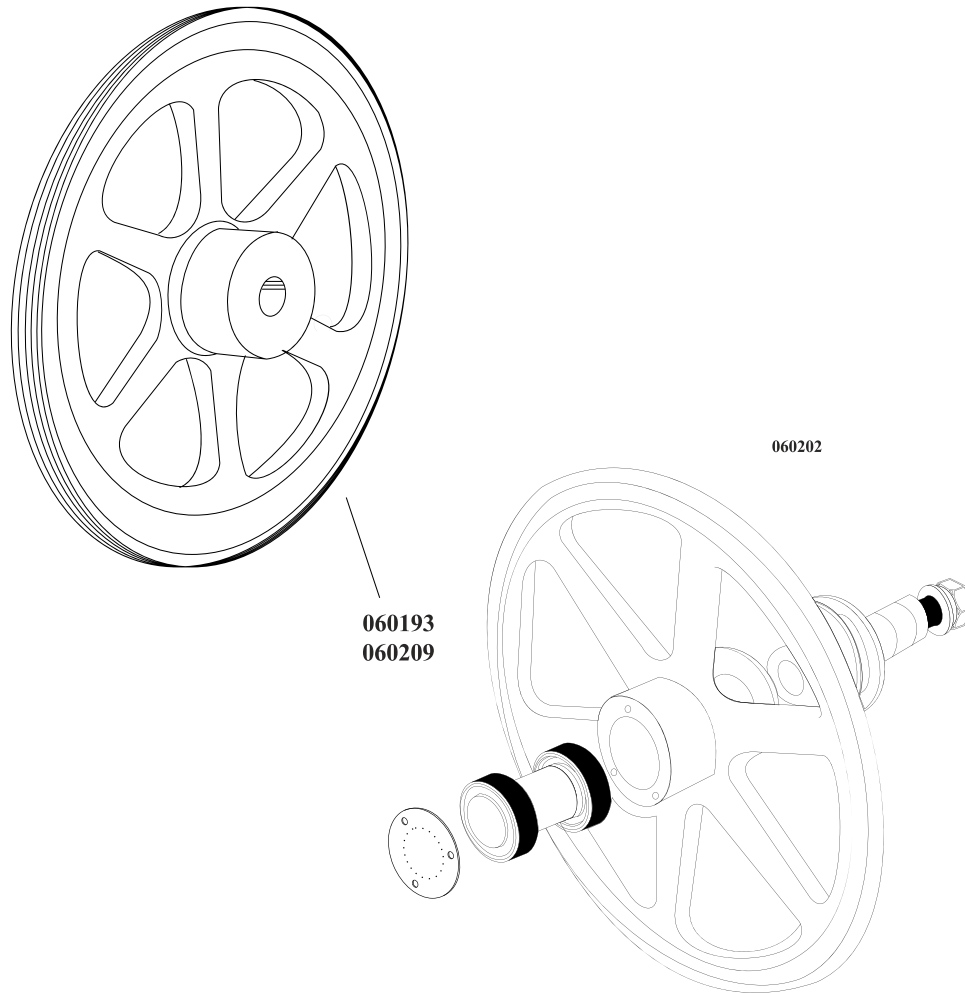

# Parts Breakdown

---

**Model BS-VE-3200-S** 10272

**Model BS-VE-3200-T** 18943

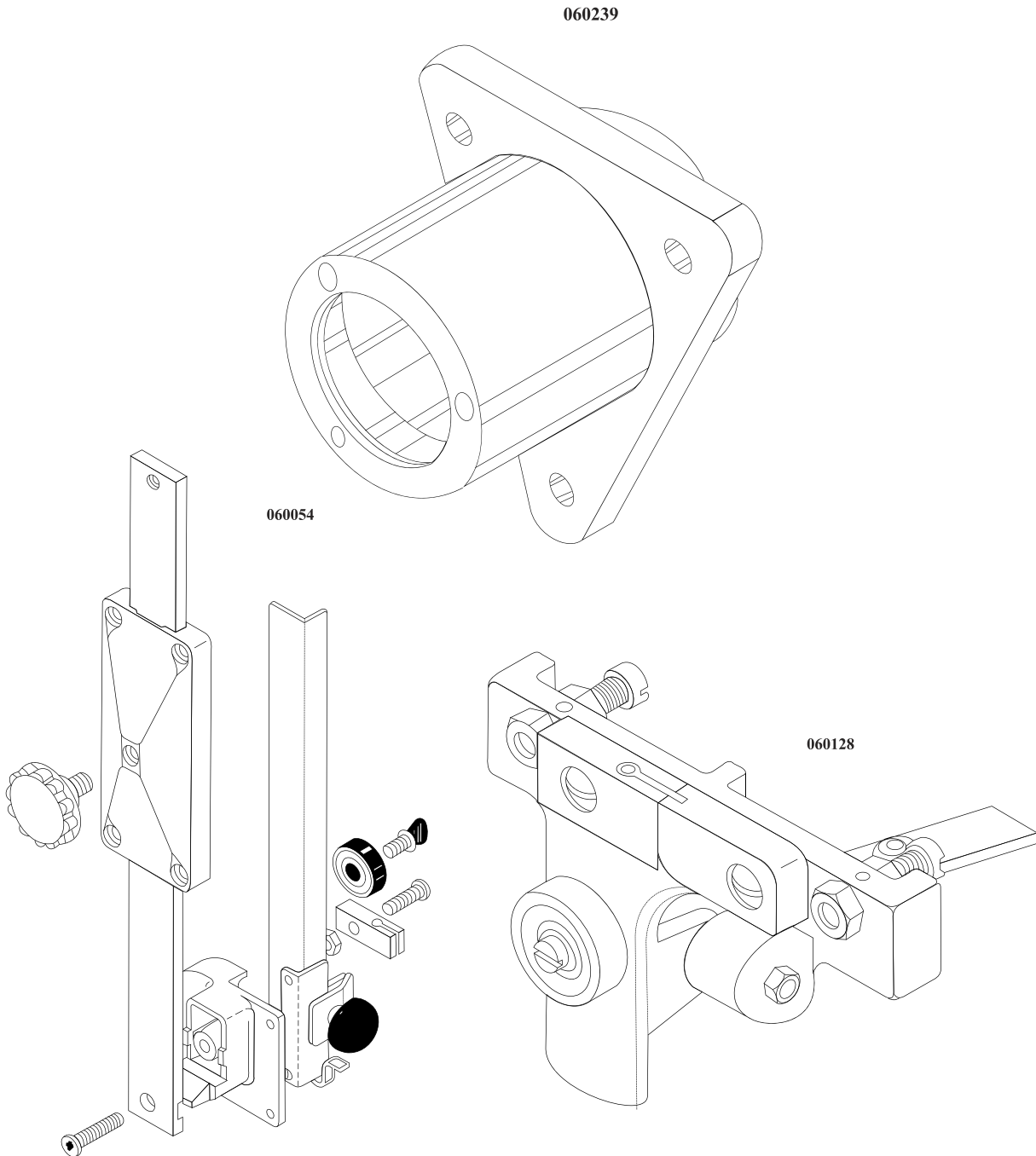



# Parts Breakdown

**Model BS-VE-3200-S** 10272

**Model BS-VE-3200-T** 18943

Item No.	Description	Position	Item No.	Description	Position	Item No.	Description	Position
62199	Front Cover for Steering Wheel for B40	06226	24156	Scraper Bracket for B40	060074	64827	Complete Strap with Iron Handle for B40	060175
64825	Steel Cover for Steering Shaft for B40	06229	62201	Switch	060076	62197	Complete Car Iron Wheel for B40	060181
45115	Washer for B40	060003	17707	Scraper for B40	060078	24155	Bolt for B40	060184
62202	Metal Tray for B40	060009	17708	Scraper for B40	060080	26129	Long Screw for Aluminum Guide for B40	060187
62185	Base with Facial Steel or Iron Roller for B40	060011	62186	Steel Handle for B40	060081	44012	Lower Shaft Nut for B40	060190
62152	Motor Base for B40	060012	44013	Micro Switch for B40	060089	24136	Pulley for B40	060193
62061	Long Door Hinge for B40	060014	62208	Complete Aluminum Housing for B40	060098	64826	Upper Flywheel Complete for B40	060197
62210	Full Arm Shield for B40	060019	24154	Pin for B40	060103	62206	Complete Upper Cylindrical Flywheel for B40	060202
23716	Belt for B40	060027	62078	Tightening Knob for B40	060107	24137	Pulley for B40	060209
45116	Pin for B40	060029	16869	Knob for B40	060108	62204	Motor Tension Screw for B40	060222
62184	Spacer for B40	060033	62192	Aluminum Front Plate for B40	060116	17717	Cover for B40	060229
62209	Arm Shaft for B40	060035	62188	Flywheel Scraper Holder for B40	060119	62200	Aluminum Housing for B40	060239
24135	Shaft for B40	060038	62203	Motor Pulley for B40	060124	62099	Door Hinge for B40	060245
24139	Shaft for B40	060042	45066	Guide for B40	060127	62102	Front Plate Screw for B40	060248
62205	Steel Square Brackets for B40	060048	23718	Guide Assembly for B40	060128	62103	Butterfly Screw for B40	060249
62065	Aluminum Flange for B40	060049	62193	Blade Protector for B40	060131	17719	Cover for B40	060251
62066	Aluminum Front for B40	060051	62164	Complete Control Box for B40	060134	31436	Housing Only for Switch for B40	060252
62207	Complete Front Plate for B40	060054	62132	Hairpin Spring for B40	060138	16873	Start Switch for B40	060253
62170	Steel Door Hook for B40	060062	17711	Clip for B40	060140	16874	Stop Switch for B40	060254
15587	Fluted Guide Pair for B40	060063	45067	Bearing 6200 for B40	060148	62143	Screw for Roller Port Guide for B40	060255
23714	Guide for B40	060064	16871	Bearing for B40	060149	45068	Screw for B40	060256
62070	Steel Guide Support for B40	060065	16872	Bearing for B40	060150	45069	Screw for B40	060257
26128	Aluminum Guide for B40	060066	62196	Complete Pulley for B40	060157	62195	Wheel Shaft for B40	060259
15590	Nylon Filler Black for B40	060069	62194	Complete Flat Wheel for B40	060161	26130	Short Screw for Aluminum Guide for B40	060261
62151	Motor Base Rubber for B40	060070	40168	Seal Model for B40	060164	39416	Motor 220/60/1 for B40	
62071	Rubber Stopper for B40	060071	62091	Aluminum Support for B40	060167	64814	Motor 220/60/3 for B40-3PH	

# Electrical Schematics

Model BS-VE-3200-S 10272

220V

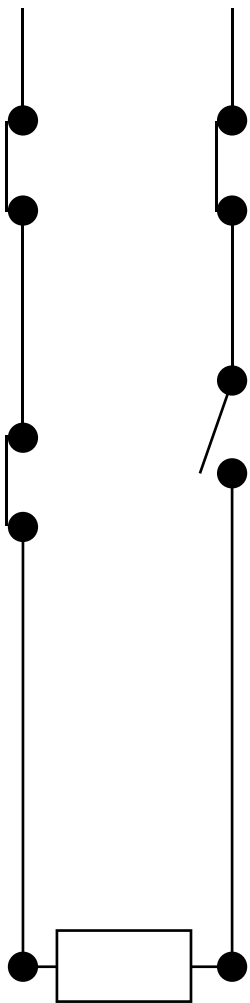

220V

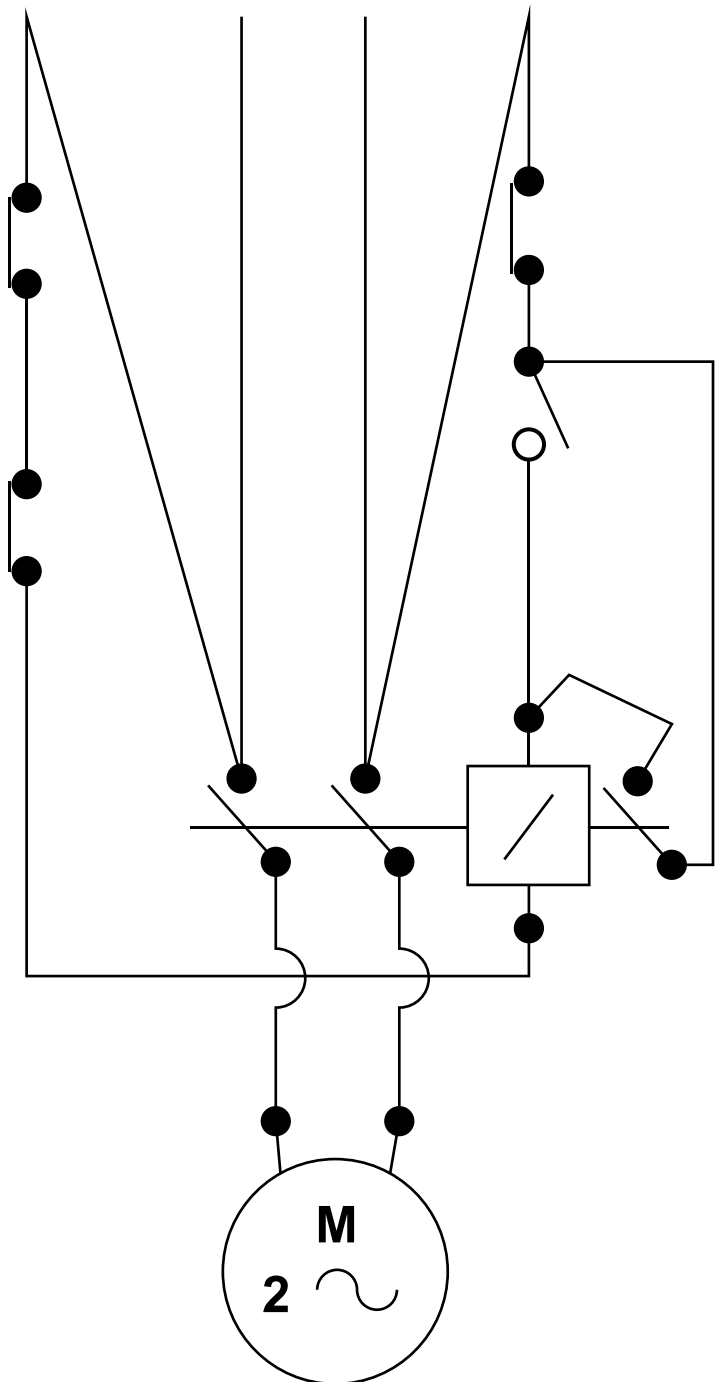

# Electrical Schematics

Model *BS-VE-3200-T* 18943

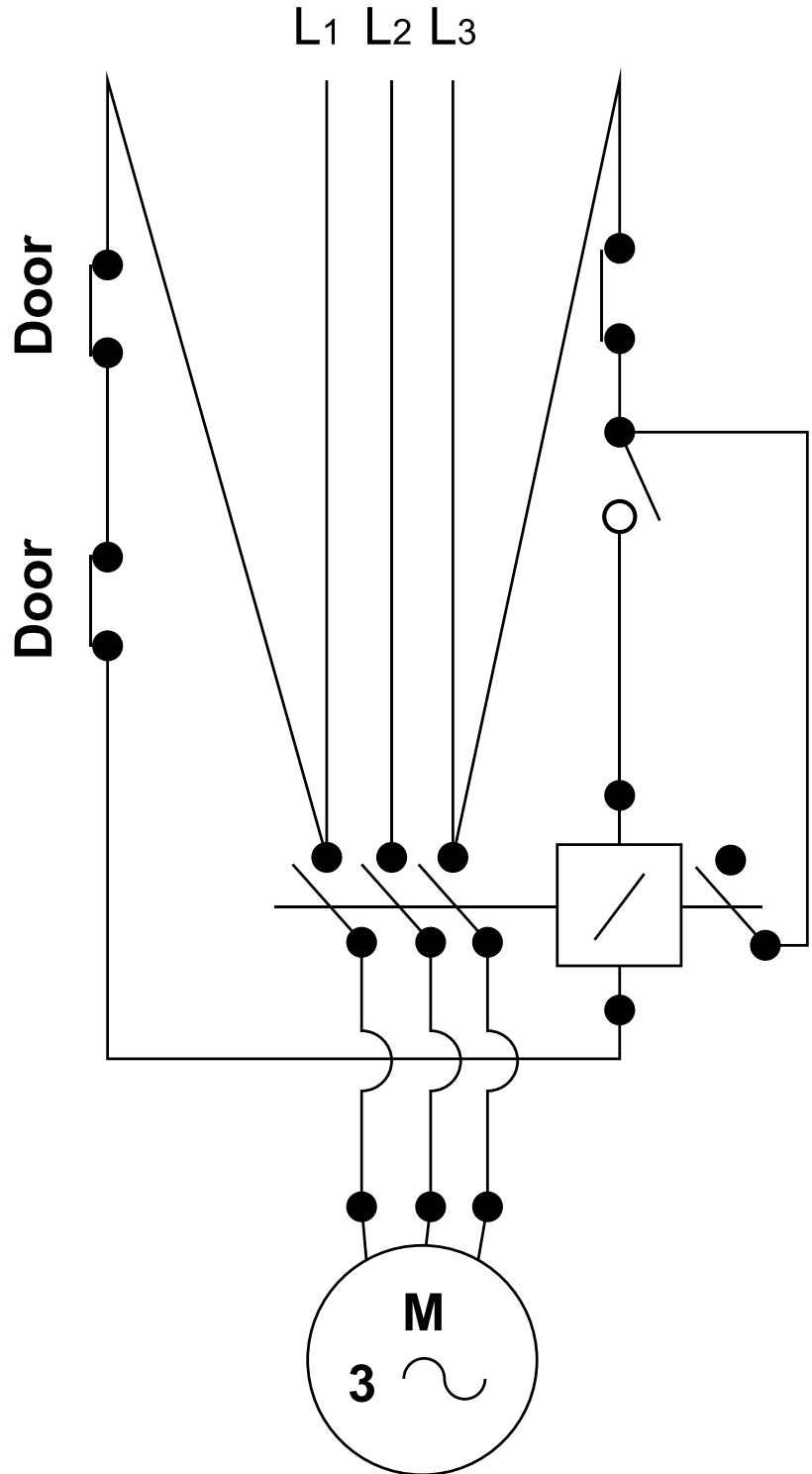
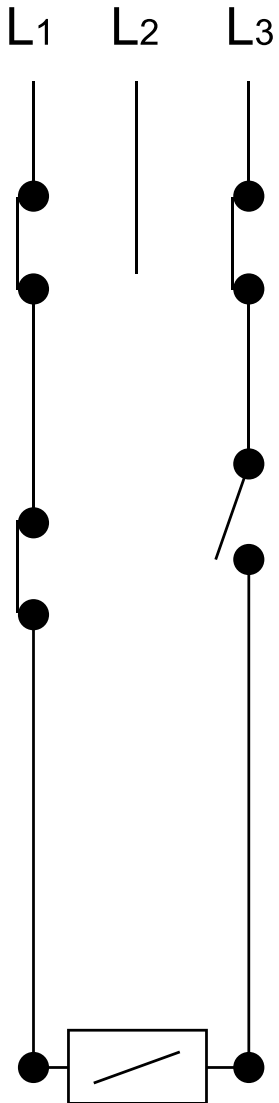









# Warranty Registration

Thank you for purchasing an Omcan product. To register your warranty for this product, complete the information below, tear off the card at the perforation and then send to the address specified below. You can also register online by visiting:

Merci d'avoir acheté un produit Omcan. Pour enregistrer votre garantie pour ce produit, complétez les informations ci-dessous, détachez la carte au niveau de la perforation, puis l'envoyer à l'adresse spécifiée ci-dessous. Vous pouvez également vous inscrire en ligne en visitant:

Gracias por comprar un producto Omcan usted. Para registrar su garantía para este producto, complete la información a continuación, cortar la tarjeta en la perforación y luego enviarlo a la dirección indicada a continuación. También puede registrarse en línea en:

<https://omcan.com/warranty-registration/>

For mailing in Canada

Pour postale au Canada

Por correo en Canadá

**OMCAN**

PRODUCT WARRANTY REGISTRATION

3115 Pepper Mill Court,

Mississauga, Ontario

Canada, L5L 4X5

For mailing in the US

Pour diffusion aux États-Unis

Por correo en los EE.UU.

**OMCAN**

PRODUCT WARRANTY REGISTRATION

4450 Witmer Industrial Estates, Unit 4,

Niagara Falls, New York

USA, 14305

*or email to: [service@omcan.com](mailto:service@omcan.com)*



Purchaser's Information

Name: \_\_\_\_\_

Address: \_\_\_\_\_

City: \_\_\_\_\_ Province or State: \_\_\_\_\_ Postal or Zip: \_\_\_\_\_

Country: \_\_\_\_\_

Dealer from which Purchased: \_\_\_\_\_

Dealer City: \_\_\_\_\_ Dealer Province or State: \_\_\_\_\_

Invoice: \_\_\_\_\_

Model Name: \_\_\_\_\_ Model Number: \_\_\_\_\_

Machine Description: \_\_\_\_\_

Date of Purchase (MM/DD/YYYY): \_\_\_\_\_

Would you like to extend the warranty?  Yes  No

Company Name: \_\_\_\_\_

Telephone: \_\_\_\_\_

Email Address: \_\_\_\_\_

Type of Company:

Restaurant  Bakery  Deli

Butcher  Supermarket  Caterer

Institution (specify): \_\_\_\_\_

Other (specify): \_\_\_\_\_

Serial Number: \_\_\_\_\_

Date of Installation (MM/DD/YYYY): \_\_\_\_\_

**Thank you for choosing Omcan | Merci d'avoir choisi Omcan | Gracias por elegir Omcan**



Since 1951 Omcan has grown to become a leading distributor of equipment and supplies to the North American food service industry. Our success over these many years can be attributed to our commitment to strengthen and develop new and existing relationships with our valued customers and manufacturers. Today with partners in North America, Europe, Asia and South America, we continually work to improve and grow the company. We strive to offer customers exceptional value through our qualified local sales and service representatives who provide convenient access to over 5,000 globally sourced products.

---

Depuis 1951 Omcan a grandi pour devenir un des “leaders” de la distribution des équipements et matériel pour l’industrie des services alimentaires en Amérique du Nord. Notre succès au cours de ces nombreuses années peut être attribué à notre engagement à renforcer et à développer de nouvelles et existantes relations avec nos clients et les fabricants de valeur. Aujourd’hui avec des partenaires en Amérique du Nord, Europe, Asie et Amérique du Sud, nous travaillons continuellement à améliorer et développer l’entreprise. Nous nous efforçons d’offrir à nos clients une valeur exceptionnelle grâce à nos ventes locales qualifiées et des représentants de service qui offrent un accès facile à plus de 5000 produits provenant du monde entier.

---

Desde 1951 Omcan ha crecido hasta convertirse en un líder en la distribución de equipos y suministros de alimentos en América del Norte industria de servicios. Nuestro éxito en estos años se puede atribuir a nuestro compromiso de fortalecer y desarrollar nuevas relaciones existentes con nuestros valiosos clientes y fabricantes. Hoy con socios de América del Norte, Europa, Asia y América del Sur, que trabajan continuamente para mejorar y crecer la empresa. Nos esforzamos por ofrecer a nuestros clientes valor excepcional a través de nuestro local de ventas y representantes de los servicios que proporcionan un fácil acceso a más de 5,000 productos con origen a nivel mundial.

