



Citrus Juicer
Model JE-IT-0900
Item 13660
Instruction Manual



Revised - 1/4/2016



Toll Free: 1-800-465-0234
Fax: 905-607-0234
Email: service@omcan.com
www.omcan.com

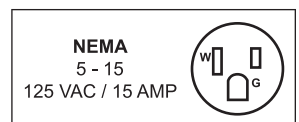

Table of Contents

Model JE-IT-0900

Section	Page
General Information -----	3 - 4
Safety and Warranty -----	4 - 6
Technical Specifications -----	6
Installation -----	7
Operation -----	7
Maintenance -----	7 - 8
Parts Breakdown -----	8 - 9
Electrical Schematics -----	10
Warranty Registration -----	11



General Information

Omcan Manufacturing and Distributing Company Inc., Food Machinery of America, Inc. dba Omcan and Omcan Inc. are not responsible for any harm or injury caused due to any person's improper or negligent use of this equipment. The product shall only be operated by someone over the age of 18, of sound mind, and not under the influence of any drugs or alcohol, who has been trained in the correct operation of this machine, and is wearing authorized, proper safety clothing. Any modification to the machine voids any warranty, and may cause harm to individuals using the machine or in the vicinity of the machine while in operation.

CHECK PACKAGE UPON ARRIVAL

Upon receipt of an Omcan shipment please inspect for external damage. If no damage is evident on the external packaging, open carton to ensure all ordered items are within the box, and there is no concealed damage to the machine. If the package has suffered rough handling, bumps or damage (visible or concealed), please note it on the bill of lading before accepting the delivery and contact Omcan within 24 hours, so we may initiate a claim with the carrier. A detailed report on the extent of the damage caused to the machine must be filled out within three days, from the delivery date shown in the shipping documents. Omcan has no recourse for damaged products that were shipped collect or third party.

Before operating any equipment, always read and familiarize yourself with all operation and safety instructions.

Omcan would like to thank you for purchasing this machine. It's of the utmost importance to save these instructions for future reference. Also save the original box and packaging for shipping the equipment if servicing or returning of the machine is required.

Omcan Fabrication et distribution Compañie Limité et Food Machinery d'Amérique, dba Omcan et Omcan Inc. ne sont pas responsables de tout dommage ou blessure causé du fait que toute personne ait utilisé cet équipement de façon irrégulière. Le produit ne doit être exploité que par quelqu'un de plus de 18 ans, saine d'esprit, et pas sous l'influence d'une drogue ou d'alcool, qui a été formé pour utiliser cette machine correctement, et est vêtu de vêtements de sécurité approprié. Toute modification de la machine annule toute garantie, et peut causer un préjudice à des personnes utilisant la machine ou des personnes à proximité de la machine pendant son fonctionnement.

VÉRIFIEZ LE COLIS DÈS RÉCEPTION

Dès réception d'une expédition d'Omcan veuillez inspecter pour dommages externes. Si aucun dommage n'est visible sur l'emballage externe, ouvrez le carton afin de s'assurer que tous les éléments commandés sont dans la boîte, et il n'y a aucun dommage dissimulé à la machine. Si le colis n'a subi aucune mauvaises manipulations, de bosses ou de dommages (visible ou cachée), notez-le sur le bond de livraison avant d'accepter la livraison et contactez Omcan dans les 24 heures qui suivent, pour que nous puissions engager une réclamation auprès du transporteur. Un rapport détaillé sur l'étendue des dommages causés à la machine doit être rempli dans un délai de trois jours, à compter de la date de livraison indiquée dans les documents d'expédition. Omcan n'a aucun droit de recours pour les produits endommagés qui ont été expédiés ou cueilli par un tiers transporteur.

General Information

Avant d'utiliser n'importe quel équipement, toujours lire et vous familiariser avec toutes les opérations et les consignes de sécurité.

Omcan voudrais vous remercier d'avoir choisi cette machine. Il est primordial de conserver ces instructions pour une référence ultérieure. Également conservez la boîte originale et l'emballage pour l'expédition de l'équipement si l'entretien ou le retour de la machine est nécessaire.

Omcan Empresa De Fabricacion Y Distribucion Inc. Y Maquinaria De Alimentos De America, Inc. dba Omcan y Omcan Inc. no son responsables de ningun daño o perjuicio causado por cualquier persona inadecuada o el uso descuidado de este equipo. El producto solo podra ser operado por una persona mayor de 18 años, en su sano juicio y no bajo alguna influencia de droga o alcohol, y que este ha sido entrenado en el correcto funcionamiento de esta máquina, y ésta usando ropa apropiada y autorizada. Cualquier modificación a la máquina anula la garantía y puede causar daños a las personas usando la máquina mientras esta en el funcionamiento.

REVISE EL PAQUETE A SU LLEGADA

Tras la recepcion de un envio Omcan favor inspeccionar daños externos. Si no hay daños evidentes en el empaque exterior, Habra el carton para asegurarse que todos los articulos solicitados estén dentro de la caja y no encuentre daños ocultos en la máquina. Si el paquete ha sufrido un manejo de poco cuidado, golpes o daños (visible o oculto) por favor anote en la factura antes de aceptar la entrega y contacte Omcan dentro de las 24 horas, de modo que podamos iniciar una reclamación con la compañía. Un informe detallado sobre los daños causados a la máquina debe ser llenado en el plazo de tres días, desde la fecha de entrega que se muestra en los documentos de envío. Omcan no tiene ningun recurso por productos dañados que se enviaron a recoger por terceros.

Antes de utilizar cualquier equipo, siempre lea y familiarizarse con todas las instrucciones de funcionamiento y seguridad.

Omcan le gustaría darle las gracias por la compra de esta máquina. Es de la mayor importancia para salvar estas instrucciones para futuras consultas. Además, guarda la caja original y el embalaje para el envío del equipo si servicio técnico o devolución de la máquina que se requiere.

Safety and Warranty

Thank you for choosing our appliance. The following are instructions for installation, use and maintenance which will ensure the long life and correct operation of your appliance. Follow these instructions carefully. We have designed and manufactured this appliance with the latest technological developments in mind.

READ THE INSTRUCTIONS CAREFULLY BEFORE INSTALLING THE MACHINE

WARNING: FAILURE TO COMPLY (EVEN PARTIALLY) WITH THE RULES GIVEN IN THIS MANUAL

Safety and Warranty

WILL INVALIDATE THE PRODUCT WARRANTY AND RELIEVES THE MANUFACTURER OF ANY RESPONSIBILITY.

WARNINGS

It is very important to keep this instruction manual near the appliance for future consultation. If the appliance is sold or transferred to another user, make sure this manual remains with the machine so that the new owner is informed about the warnings and operation of the appliance. These instructions are given for safety reasons. They must be read carefully before installing and using the appliance.

- If the appliance seems damaged after removing the packaging, contact the retailer before using it.
- Any changes made to the electric circuit when installing the appliance must be done by a qualified technician.
- Make sure that the electric circuit is properly grounded and conforms to the regulations in force.
- The appliance must be used by adults only.
- After the use it is suggested to disconnect the appliance from the electric supply by switching the machine off and unplugging the power cord from the socket.

The main wall switch must be of the multipolar type with a contact opening of at least 3 mm.

- Any intervention to repair the appliance is not allowed for the user. Please contact a qualified technician.
- Under no circumstances should the user attempt to carry out repairs. Contact a qualified and authorized technician.

Please use only original spare parts. Otherwise the product guarantee and the manufacturer's responsibility is forfeited.

- This appliance shall be used exclusively for the purpose for which it was designed. Any other use shall be considered improper and therefore dangerous. Do not use the appliance to mix dangerous liquids or any other non-organic liquid.
- When using this appliance, it is important to observe the following rules:
 1. Never touch the appliance with wet hands or feet;
 2. The appliance should never be used by persons with bare feet;
 3. Do not install the appliance in areas exposed to pressurised water spray;
 4. Never pull on the power cord to disconnect the appliance from the mains.
- This appliance can work until a maximum room temperature of 35°C.

The Manufacturer cannot be held responsible for damage or injury caused by failure to observe the above rules.

1 YEAR PART AND LABOUR BENCH WARRANTY

Within the warranty period, contact Omcan Inc. at 1-800-465-0234 to schedule a drop off to either an Omcan authorized service depot in the area, or to an Omcan Service warehouse to repair the equipment.

Safety and Warranty

Unauthorized maintenance will void the warranty. Warranty covers electrical and part failures, not improper use.

Please see www.omcan.com/warranty.html for complete info.

WARNING:

The packaging components are classified as normal solid urban waste and can therefore be disposed of without difficulty.

In any case, for suitable recycling, we suggest disposing of the products separately (differentiated waste) according to the current norms.

DO NOT DISCARD ANY PACKAGING MATERIALS IN THE ENVIRONMENT!

Technical Specifications

Model	JE-IT-0900
Power	250 Watts
Electrical	110V/60/1
Weight	17 lbs. / 7.7 kgs.
Dimensions	7" x 9.5" x 12.5" / 178 x 241 x 318mm
Item Number	13660

The packing consists of the following:

- A wooden pallet;
- A nylon (LDPE) bag;
- A multilayer cardboard box;
- A polystyrene foam (PS);
- Polypropylene (PP) straps.

Please dispose of the materials listed above, according to the current regulations.

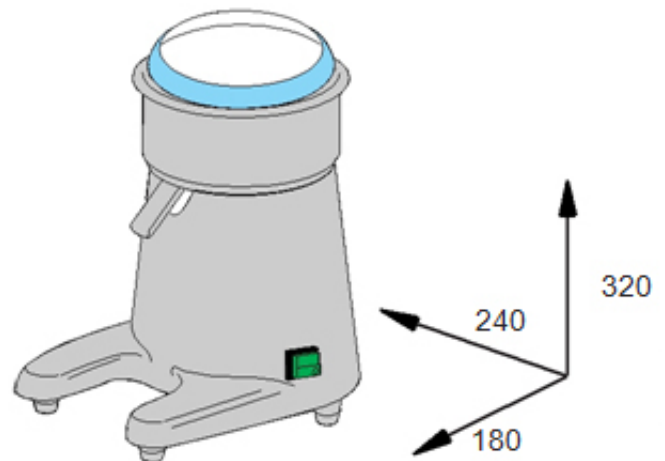

Installation

INSTALLATION TO BE DONE BY LICENSED PROFESSIONALS ONLY.

UNPACKING AND PREPARING THE APPLIANCE FOR USE

- Unpack the appliance and remove the packing material.
- Place the appliance on a surface which is not slippery.

CONNECTION TO THE MAINS

The connection to the electric supply have to be made by a magnetothermic omnipolar switch, with distance of 3 mm between any objects, fuses, or by a differential properly sized according to the electric norms in force. This socket must be dedicated to the appliance. Make sure that there is a proper grounded connection.

The appliance is equipped with a 110V/60 Hz connection.

Operation

Plug the juicer into a standard wall socket. Press switch 0-1 (A) to position (1) for operation.

When the switch has been pressed, cut the fruit to be squeezed in equal halves, take one of them and place it on the spinner, being careful not to turn it.

The juice will pass through the filter into the bowl where it runs into a drainage tube and is collected in the juice collector cup placed beneath the tube.

Useful advice

The juicer should only be used for the time period necessary to squeeze the fruit. Therefore, do not operate the appliance for long periods of time when it is empty. After using the appliance, it is advisable to disconnect it from the mains by means of the main wall switch. In case of prolonged work, the gear has a thermic switch which will temporarily turn off the gear to let it cool.

Maintenance

Before proceeding with maintenance or cleaning, make sure that the appliance is disconnected from the power main. No particular maintenance is required. It is advisable to always clean the appliance, the reamer, the filter and the bowl. To do so, use a damp cloth. The filter and the crown can be removed by extracting them up and rinsed under running water. It is suggested not to wash the appliance under water jets because the item is not protected against pressurized water sprays. Never use bleach or chlorine detergents to clean the appliance.

Maintenance

DISPOSAL

The use of the WEEE Symbol indicates that this product may not be treated as household waste. By ensuring this product is disposed of correctly you will help protect the environment. For more detailed information about the recycling of this product, please contact your local authority, your household waste disposal service provider or the shop where you purchased the product. For the disposal of the machine or one of its part, please follow the directives 2002/95/CE, 2002/96/CE and following changes and/or the legislative decrees of application. This product or parts of it cannot be disposed of as domestic waste but must be treated by means of separate collection (see barred waste container symbol on product). At the time of product disposal, the user must refer to the specific waste collection systems for electric and electronic appliances (WEEE). The manufacturer guarantees the absence of dangerous substances in the EEE's used in compliance with the 200/95/CE Directive. In the case of failure to comply with that prescribed, the user will be subject to the sanctions envisioned by the local government. Disconnect the machine from the electrical and water supply before disposal. Cut off the electrical cable in order to make any other use impossible. All the metal parts are recyclable as they are in stainless steel. Recyclable plastic parts are marked with the symbol of the plastic material.

REFERENCE

Item Number	Model Number	Description	Manufacturer Model Number
13660	JE-IT-0900	Juice Extractor Citrus 900 RPM 0.25 HP / 250 W 110V/60/1	S40

Parts Breakdown

Model JE-IT-0900 13660

Item No.	Description	Position	Item No.	Description	Position	Item No.	Description	Position
75403	Capacitor for S40	1300	75410	Large Spinner for S40	1335	75417	Protective Bottom for S40	1370
75404	Single Green Button Switch for S40	1305	75411	Stainless Steel Sieve for S40	1340	75418	Cable Terminal for S40	1375
75405	Power Cable for S40	1310	75412	Stainless Steel Tank for S40	1345	75419	V-Ring for S40	1380
75406	Rubber Foot for S40	1315	75413	Slot for Spinner for S40	1350	75420	Aluminum Frame for S40	1385
75407	Sauce Clip Holder for S40	1320	75414	Washer for S40	1355	75421	Terminal for S40	1390
75408	Motor for S40	1325	75415	O-Ring 16.64 x 3.53 for S40	1360	75422	Plastic Guard for S40	1395
75409	Small Spinner for S40	1330	75416	Support Tray for S40	1365			

Parts Breakdown

Model JE-IT-0900 13660

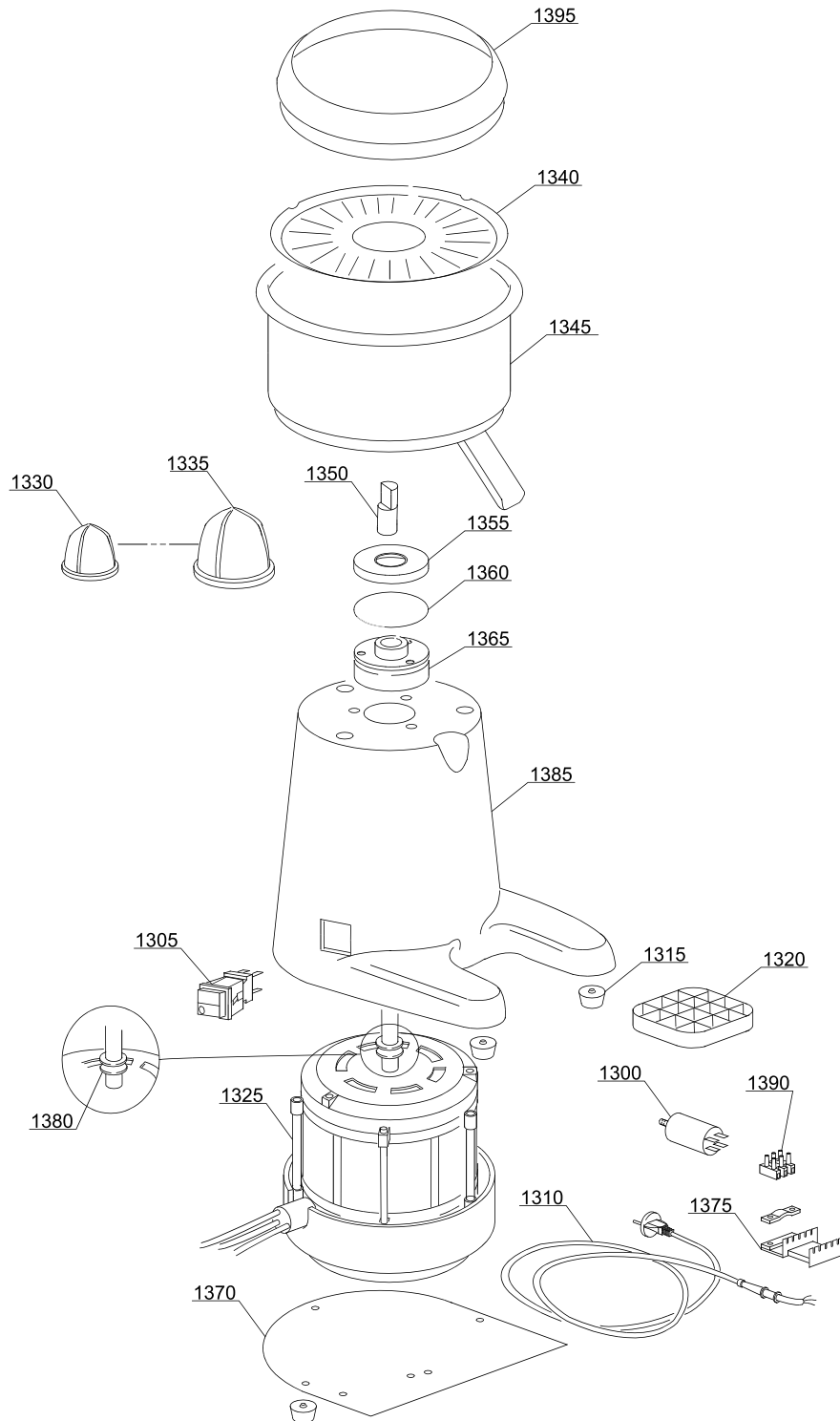

Electrical Schematics

Model JE-IT-0900 13660

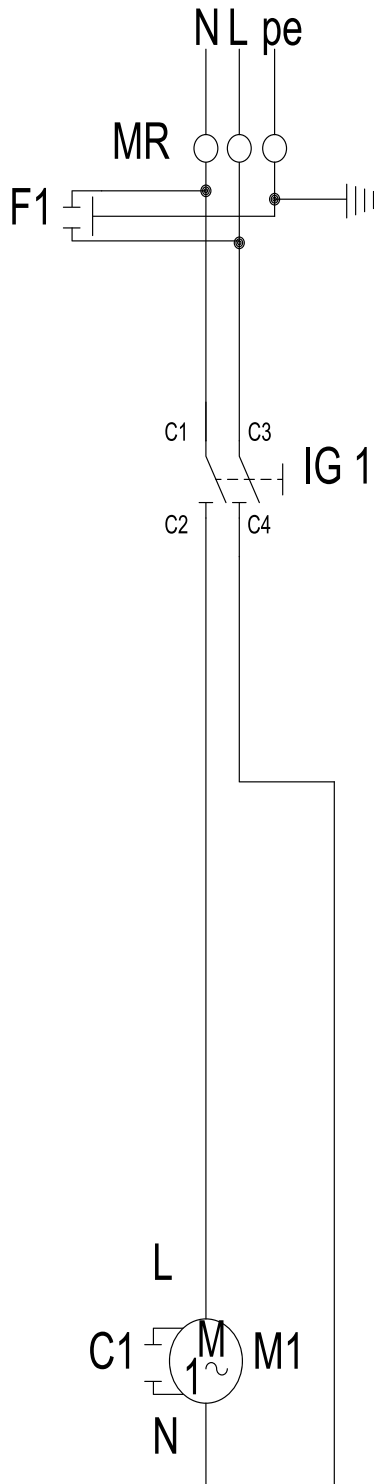

LEGEND

MR TERMINAL BOARD
 IG1 MAIN SWITCH
 MS SAFETY MICRO
 C1 CONDENSER
 F1 LOW NOISE FILTER
 MI MOTOR



Warranty Registration

Thank you for purchasing an Omcan product. To register your warranty for this product, complete the information below, tear off the card at the perforation and then send to the address specified below. You can also register online by visiting:

Merci d'avoir acheté un produit Omcan. Pour enregistrer votre garantie pour ce produit, complétez les informations ci-dessous, détachez la carte au niveau de la perforation, puis l'envoyer à l'adresse spécifiée ci-dessous. Vous pouvez également vous inscrire en ligne en visitant:

Gracias por comprar un producto Omcan usted. Para registrar su garantía para este producto, complete la información a continuación, cortar la tarjeta en la perforación y luego enviarlo a la dirección indicada a continuación. También puede registrarse en línea en:

www.omcan.com/warrantyregistration.html



For mailing in Canada
Pour postale au Canada
Por correo en Canadá

For mailing in the US
Pour diffusion aux États-Unis
Por correo en los EE.UU.

OMCAN INC.
PRODUCT WARRANTY REGISTRATION
3115 Pepper Mill Court,
Mississauga, Ontario
Canada, L5L 4X5

OMCAN
PRODUCT WARRANTY REGISTRATION
4450 Witmer Industrial Estates, Unit 4,
Niagara Falls, New York
USA, 14305



Purchaser's Information

Name: _____

Address: _____

City: _____ Province or State: _____ Postal or Zip: _____

Country: _____

Dealer from which Purchased: _____

Dealer City: _____ Dealer Province or State: _____

Invoice: _____

Company Name: _____

Telephone: _____

Email Address: _____

Type of Company:

Restaurant Bakery Deli

Butcher Supermarket Caterer

Institution (specify): _____

Other (specify): _____

Model Name: _____ Model Number: _____

Serial Number: _____

Machine Description: _____

Date of Purchase (MM/DD/YYYY): _____

Date of Installation (MM/DD/YYYY): _____

Thank you for choosing Omcan | Merci d'avoir choisi Omcan | Gracias por elegir Omcan



Since 1951 Omcan has grown to become a leading distributor of equipment and supplies to the North American food service industry. Our success over these many years can be attributed to our commitment to strengthen and develop new and existing relationships with our valued customers and manufacturers. Today with partners in North America, Europe, Asia and South America, we continually work to improve and grow the company. We strive to offer customers exceptional value through our qualified local sales and service representatives who provide convenient access to over 3,500 globally sourced products.

Depuis 1951 Omcan a grandi pour devenir un des “leaders” de la distribution des équipements et matériel pour l’industrie des services alimentaires en Amérique du Nord. Notre succès au cours de ces nombreuses années peut être attribué à notre engagement à renforcer et à développer de nouvelles et existantes relations avec nos clients et les fabricants de valeur. Aujourd’hui avec des partenaires en Amérique du Nord, Europe, Asie et Amérique du Sud, nous travaillons continuellement à améliorer et développer l’entreprise. Nous nous efforçons d’offrir à nos clients une valeur exceptionnelle grâce à nos ventes locales qualifiées et des représentants de service qui offrent un accès facile à plus de 3500 produits provenant du monde entier.

Desde 1951 Omcan ha crecido hasta convertirse en un líder en la distribución de equipos y suministros de alimentos en América del Norte industria de servicios. Nuestro éxito en estos años se puede atribuir a nuestro compromiso de fortalecer y desarrollar nuevas relaciones existentes con nuestros valiosos clientes y fabricantes. Hoy con socios de América del Norte, Europa, Asia y América del Sur, que trabajan continuamente para mejorar y crecer la empresa. Nos esforzamos por ofrecer a nuestros clientes valor excepcional a través de nuestro local de ventas y representantes de los servicios que proporcionan un fácil acceso a más de 3,500 productos con origen a nivel mundial.

