



Pizza Ovens
Models PE-IT-0019-S, 0038-D
Items 40635, 40636
Instruction Manual



Revised - 12/13/2019



Toll Free: 1-800-465-0234
Fax: 905-607-0234
Email: service@omcan.com
www.omcan.com



Table of Contents

Model PE-IT-0019-S / Model PE-IT-0038-D

Section	Page
General Information -----	3 - 4
Safety and Warranty -----	4 - 6
Technical Specifications -----	6
Installation -----	7
Operation -----	7 - 8
Maintenance -----	8 - 9
Troubleshooting -----	9 - 10
Parts Breakdown -----	11 - 14
Electrical Schematics -----	15 - 16
Notes -----	17 - 18
Warranty Registration -----	19



General Information

Omcan Manufacturing and Distributing Company Inc., Food Machinery of America, Inc. dba Omcan and Omcan Inc. are not responsible for any harm or injury caused due to any person's improper or negligent use of this equipment. The product shall only be operated by someone over the age of 18, of sound mind, and not under the influence of any drugs or alcohol, who has been trained in the correct operation of this machine, and is wearing authorized, proper safety clothing. Any modification to the machine voids any warranty, and may cause harm to individuals using the machine or in the vicinity of the machine while in operation.

CHECK PACKAGE UPON ARRIVAL

Upon receipt of an Omcan shipment please inspect for external damage. If no damage is evident on the external packaging, open carton to ensure all ordered items are within the box, and there is no concealed damage to the machine. If the package has suffered rough handling, bumps or damage (visible or concealed), please note it on the bill of lading before accepting the delivery and contact Omcan within 24 hours, so we may initiate a claim with the carrier. A detailed report on the extent of the damage caused to the machine must be filled out within three days, from the delivery date shown in the shipping documents. Omcan has no recourse for damaged products that were shipped collect or third party.

Before operating any equipment, always read and familiarize yourself with all operation and safety instructions.

Omcan would like to thank you for purchasing this machine. It's of the utmost importance to save these instructions for future reference. Also save the original box and packaging for shipping the equipment if servicing or returning of the machine is required.

Omcan Fabrication et distribution Compañie Limité et Food Machinery d'Amérique, dba Omcan et Omcan Inc. ne sont pas responsables de tout dommage ou blessure causé du fait que toute personne ait utilisé cet équipement de façon irrégulière. Le produit ne doit être exploité que par quelqu'un de plus de 18 ans, saine d'esprit, et pas sous l'influence d'une drogue ou d'alcool, qui a été formé pour utiliser cette machine correctement, et est vêtu de vêtements de sécurité approprié. Toute modification de la machine annule toute garantie, et peut causer un préjudice à des personnes utilisant la machine ou des personnes à proximité de la machine pendant son fonctionnement.

VÉRIFIEZ LE COLIS DÈS RÉCEPTION

Dès réception d'une expédition d'Omcan veuillez inspecter pour dommages externes. Si aucun dommage n'est visible sur l'emballage externe, ouvrez le carton afin de s'assurer que tous les éléments commandés sont dans la boîte, et il n'y a aucun dommage dissimulé à la machine. Si le colis n'a subi aucune mauvaises manipulations, de bosses ou de dommages (visible ou cachée), notez-le sur le bond de livraison avant d'accepter la livraison et contactez Omcan dans les 24 heures qui suivent, pour que nous puissions engager une réclamation auprès du transporteur. Un rapport détaillé sur l'étendue des dommages causés à la machine doit être rempli dans un délai de trois jours, à compter de la date de livraison indiquée dans les documents d'expédition. Omcan n'a aucun droit de recours pour les produits endommagés qui ont été expédiés ou cueilli par un tiers transporteur.

General Information

Avant d'utiliser n'importe quel équipement, toujours lire et vous familiariser avec toutes les opérations et les consignes de sécurité.

Omcan voudrais vous remercier d'avoir choisi cette machine. Il est primordial de conserver ces instructions pour une référence ultérieure. Également conservez la boîte originale et l'emballage pour l'expédition de l'équipement si l'entretien ou le retour de la machine est nécessaire.

Omcan Empresa De Fabricacion Y Distribucion Inc. Y Maquinaria De Alimentos De America, Inc. dba Omcan y Omcan Inc. no son responsables de ningun daño o perjuicio causado por cualquier persona inadecuada o el uso descuidado de este equipo. El producto solo podra ser operado por una persona mayor de 18 años, en su sano juicio y no bajo alguna influencia de droga o alcohol, y que este ha sido entrenado en el correcto funcionamiento de esta máquina, y ésta usando ropa apropiada y autorizada. Cualquier modificación a la máquina anula la garantía y puede causar daños a las personas usando la máquina mientras esta en el funcionamiento.

REVISE EL PAQUETE A SU LLEGADA

Tras la recepcion de un envio Omcan favor inspeccionar daños externos. Si no hay daños evidentes en el empaque exterior, Habra el carton para asegurarse que todos los articulos solicitados estén dentro de la caja y no encuentre daños ocultos en la máquina. Si el paquete ha sufrido un manejo de poco cuidado, golpes o daños (visible o oculto) por favor anote en la factura antes de aceptar la entrega y contacte Omcan dentro de las 24 horas, de modo que podamos iniciar una reclamación con la compañía. Un informe detallado sobre los daños causados a la máquina debe ser llenado en el plazo de tres días, desde la fecha de entrega que se muestra en los documentos de envío. Omcan no tiene ningun recurso por productos dañados que se enviaron a recoger por terceros.

Antes de utilizar cualquier equipo, siempre lea y familiarizarse con todas las instrucciones de funcionamiento y seguridad.

Omcan le gustaría darle las gracias por la compra de esta máquina. Es de la mayor importancia para salvar estas instrucciones para futuras consultas. Además, guarda la caja original y el embalaje para el envío del equipo si servicio técnico o devolución de la máquina que se requiere.

Safety and Warranty

WARNINGS FOR THE INSTALLER

Check that the location of the oven is in compliance with local regulations.

- Adhere to the instructions in this manual.
- Do not execute electrical connections using temporary or uninsulated cables.
- Check that the ground connection of the electrical system is functioning properly.
- Always use individual safety devices and other means of protection in compliance with the law.

Safety and Warranty

WARNING FOR THE USER

The conditions in the surrounding area where the machine will be installed must have the following characteristics:

- The area must be dry.
- The area must have water and heat sources at an adequate distance.
- Ventilation and lighting must be suitable and comply with the hygiene and safety standards foreseen by current laws.
- The floor must be flat and compact to facilitate thorough cleaning.
- There must be no obstacles of any kind in the immediate vicinity of the machine that could effect the machine's normal ventilation.

In addition, the user must:

- Make certain to keep children away from the machine when it is operating.
- Adhere to the instructions in this manual.
- Not remove or tamper with the safety devices on the machine.
- Always pay careful attention to the work at hand and not use the machine when in a distracted state.
- Perform all operations with maximum safety and calm.
- Respect the instructions and warnings displayed on the machine labels.

The labels are accident prevention devices, and therefore must always be perfectly legible. If these should be damaged and illegible, it is mandatory to replace them by requesting replacements from the Manufacturer.

- At the end of each working shift, before cleaning, maintenance or transfer operations, disconnect electrical power.

WARNINGS FOR THE MAINTENANCE OPERATOR

Observe the instructions indicated in this manual.

- Always use individual safety devices and other protection means.
- Before starting any maintenance operations, make sure that the oven, it was used, is cooled down.
- If any of the safety devices is worn or faulty, the oven is also considered faulty and not to be used.
- Disconnect electrical power before intervening on electrical or electronic parts and connectors.

1 YEAR PARTS AND LABOUR WARRANTY

Within the warranty period, contact Omcan Inc. at 1-800-465-0234 to schedule an Omcan authorized service technician to repair the equipment locally.

Unauthorized maintenance will void the warranty. Warranty covers electrical and part failures, not improper use.

Please see <https://omcan.com/disclaimer> for complete info.

Safety and Warranty

WARNING:

The packaging components are classified as normal solid urban waste and can therefore be disposed of without difficulty.

In any case, for suitable recycling, we suggest disposing of the products separately (differentiated waste) according to the current norms.

DO NOT DISCARD ANY PACKAGING MATERIALS IN THE ENVIRONMENT!

Technical Specifications

Model	PE-IT-0019-S	PE-IT-0038-D
Maximum Temperature	450°C / 842°F	
Electrical	220V / 60Hz / 3Ph	
Power	5600 W	11200 W
Pizza per Hour (14" Pizza)	48	96
Bake Time for 13"-14" Pizza*	4-6 mins	
Chamber Dimensions	27.6" x 27.6" x 5.9" 701 x 701 x 150mm	(27.6" x 27.6" x 5.9") x 2 (701 x 701 x 150mm) x 2
Chamber Dimensions with Full Refractory Stone	26.4" x 27" x 5.3" 671 x 686 x 135mm	(26.4" x 27" x 5.3") x 2 (671 x 686 x 135mm) x 2
External Dimensions	39" x 36.2" x 14.9" 991 x 919 x 378mm	39" x 36.2" x 26.7" 991 x 919 x 678mm
Weight	163 lbs. / 73.9 kgs.	328.5 lbs. / 149 kgs.
Weight with Full Refractory Stone	211 lbs. / 95.7 kgs.	425 lbs. / 192.8 kgs.
Item Number	40635	40636

**Bake time may vary depending on the toppings and dough consistency.*

Installation

Installation must be executed by qualified personnel in compliance with local regulations.

EQUIPMENT HOOK-UP

The oven is not provided with power supply cable. When connecting the appliance electrically, an automatic RCD must be interposed with an opening distance between contacts of at least 3 mm. To connect the appliance electrically it is essential to proceed in the following way:

- Raise the cover of the terminal block.
- Connect to the terminal block the power cable.

The power supply cable must be of H07-RNF type, with approved minimum cross section as prescribed by the specific directive.

The electrical outlet must be easy to access, no moving should be necessary.

It is mandatory that the electrical system is equipped with a ground connection.

The appliance must be part of an equipotential system. The connection is done on terminal marked with symbol which you will find near the cable clamp. The section of the equipotential wire must be at least 10 mm².

The equipotential symbol is showed in the following figure.



Operation

COMMAND PANEL DESCRIPTION

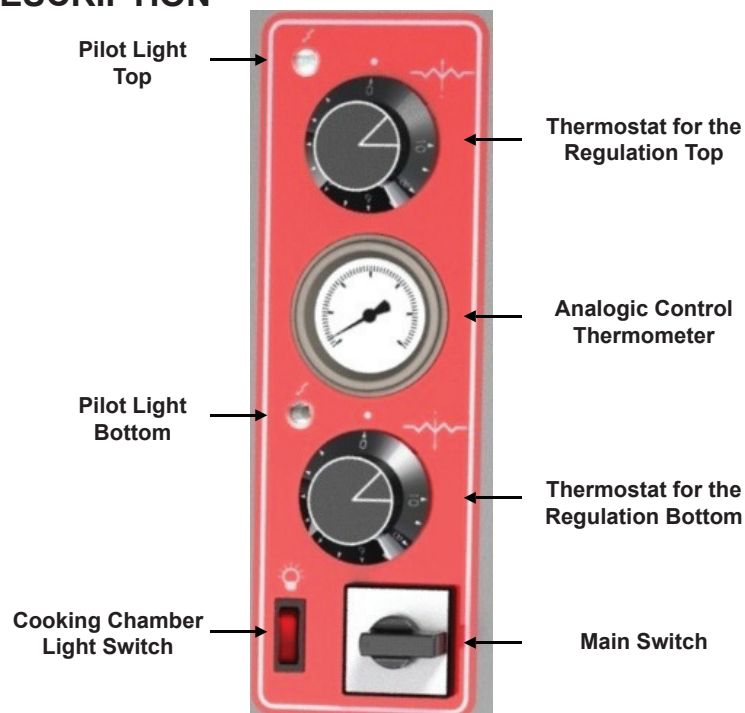

Operation

FIRST LIGHTING OF THE OVEN

At the first use of the appliance it is advisable to heat the empty oven to eliminate bad smells caused by the refractory stones evaporation and the inner metallic parts.

Procedure:

- Fully open the exhauster valve.
- Turn the main switch in position "1".
- Leave the oven working (empty) for at least 8 hours at the temperature of 300° before proceeding to the first baking.

START UP PHASE

The analogical thermometer display shows the actual average temperature of the baking chamber. Rotate the thermostat knobs and until the expected temperature. In this way top and bottom heating elements are under working and the relevant light signals switch on.

USE OF EXHAUSTER VALVE

While baking regulate the valve according to the exigencies. Oven is under heating; so, the set temperature is reached in shortest possible time. By the exhauster valve the operator can regulate the baking steams and fumes flow out from the baking chamber, while in the same the heat is kept.

SHUT DOWN PHASE

To shut down the oven turn the thermostat to the position "0".

Maintenance

SAFETY PRECAUTIONS

Before performing any maintenance operations, including cleaning, take the following precautions:

- Ensure that the oven is not working and completely cold.
- Ensure that the electrical power is not present.
- Make certain that the electrical power cannot be accidentally reinserted. Disconnect the plug from the electrical power socket.
- Use individual protection devices in compliance with the directive 89/391/CEE.
- Always operate using appropriate maintenance tools.
- Once maintenance and repairs are finished, before starting up the oven, reinstall all of the protection devices and reactivate all of the safety devices.

Maintenance

ORDINARY MAINTENANCE FOR THE USER

As any equipment also our ovens requires simple, frequent and careful cleaning to ensure efficient, regular functioning. It is recommended to never use chemical products which are not specific for food preparation areas, abrasives or corrosives for any reason. Avoid by all means using water jets, tools, rough or abrasive instruments, such as steel wool, brillo sponges or any other item which could damage the surface of the machine, and especially those that could compromise health safety. Oven external areas cleaning, external parts in stainless steel, door glass, and switch panel, must be carried out at cold oven and at disconnected electric power supply. Use a sponge or a soft cloth, not abrasive, slightly humidified with water or possibly with a neutral detergent not corrosive. In any case, do not use water jets which can penetrate through the electric parts and heavily damage them, as well as bring a possible danger for people.

Troubleshooting

SYMPTOM	POSSIBLE CAUSE	SUGGESTED REMEDY
The oven does not heat even though the temperatures are set correctly. The pilot lights are off.	Main switch in position "0".	Turn the main switch in position "1".
The oven doesn't heat despite the main switch is on (position 1) and the temperatures are correctly set. The function pilot lights of the heating elements are off.	No electric Energy in the net.	Check the general contactor, the socket, the plug, and the supply cable.
The analogical thermometer doesn't notice the increase of the temperature despite the heating elements are correctly functioning.	Analogical thermometer defect.	Check and if necessary replace the thermometer.
Inner light bulb does not switch on.	Burned inner light bulb.	Replace inner light bulb.
	Inner light bulb switch defected.	Replace light bulb switch.
	No electric supply power on the light bulb.	Check electric connection with the light bulb.
The door is closed, but fume comes out.	Exhauster butterfly valve closed.	Open more the valve and check the right functioning.
The baking chamber does not heat suitably.	The set temperature are too low.	Set the right temperature.
The baking chamber does not heat suitably in spite of the temperature being set rightly.	One or more heating elements are defected.	Replace the defecate heating elements.

Troubleshooting

The temperature continues going up over the set by thermostats.	Thermostat probe or thermostat contacts defected.	Check and if necessary replace the thermostats.
The door does not keep right closed.	The door closing spring has subsiding.	Disassemble the left side panel and replace the spring.

REFERENCE

Item Number	Model Number	Description	Manufacturer Model Number
40635	PE-IT-0019-S	Pizza Oven Entry Max Series Single Chamber 27.5" x 27.5" x 5.9" 220/60/3 cQPSus	ENTRY MAX 4
40636	PE-IT-0038-D	Pizza Oven Entry Max Series Double Chamber 27.5" x 27.5" x 5.9" 220/60/3 cQPSus	ENTRY MAX 8

Parts Breakdown

Model PE-IT-0019-S 40635

Model PE-IT-0038-D 40636

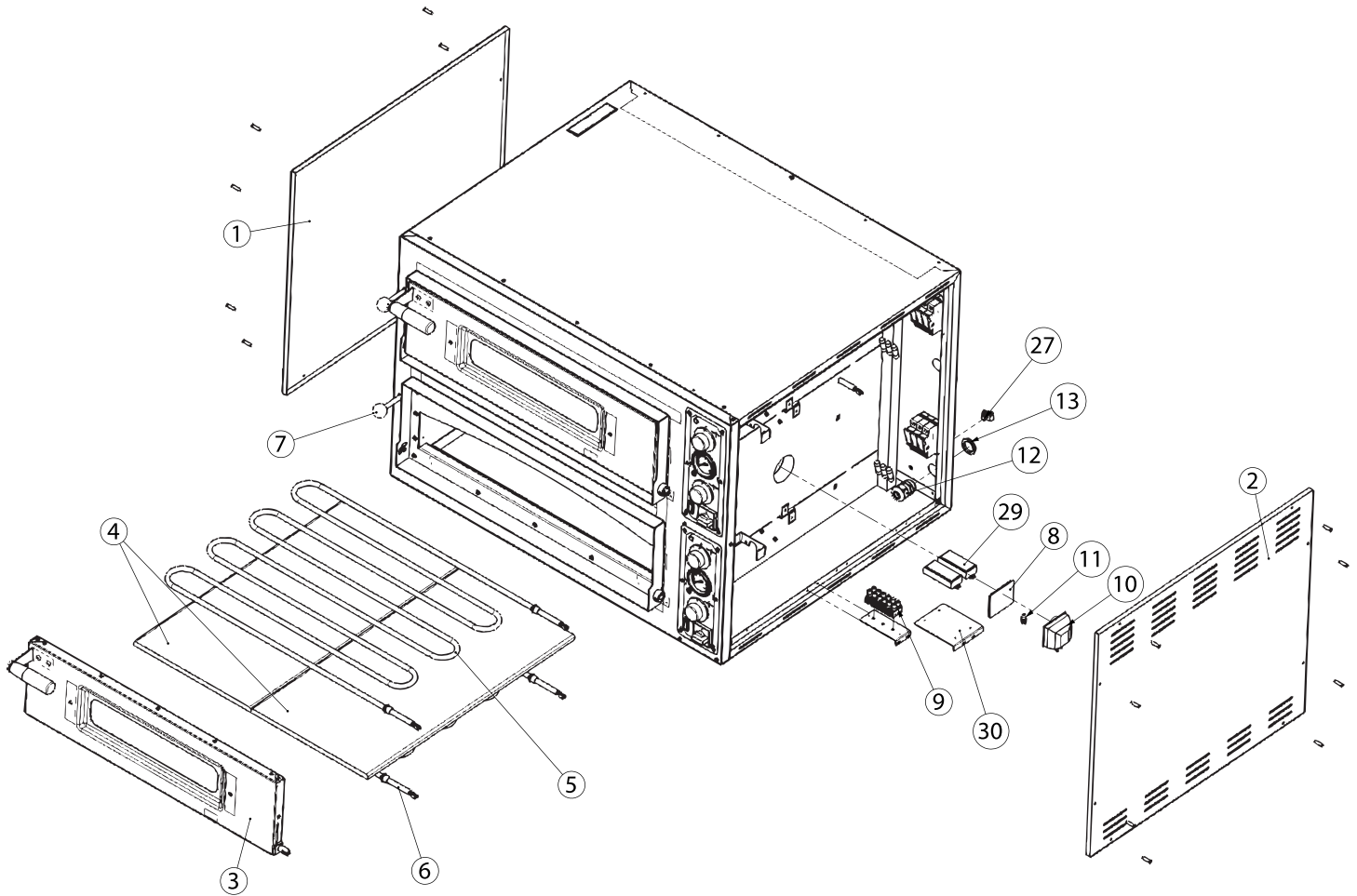

Parts Breakdown

Model PE-IT-0019-S 40635

Model PE-IT-0038-D 40636

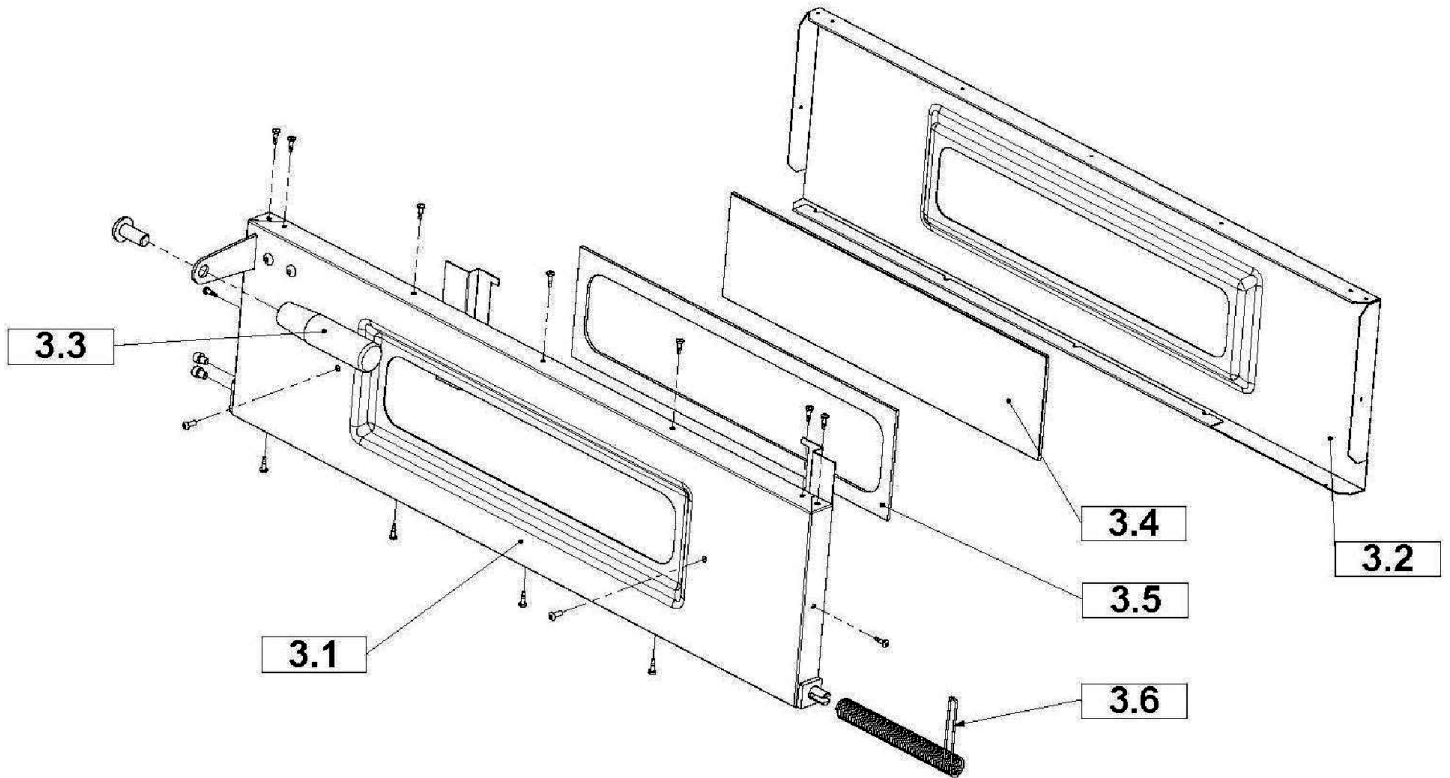

Parts Breakdown

Model PE-IT-0019-S 40635

Model PE-IT-0038-D 40636

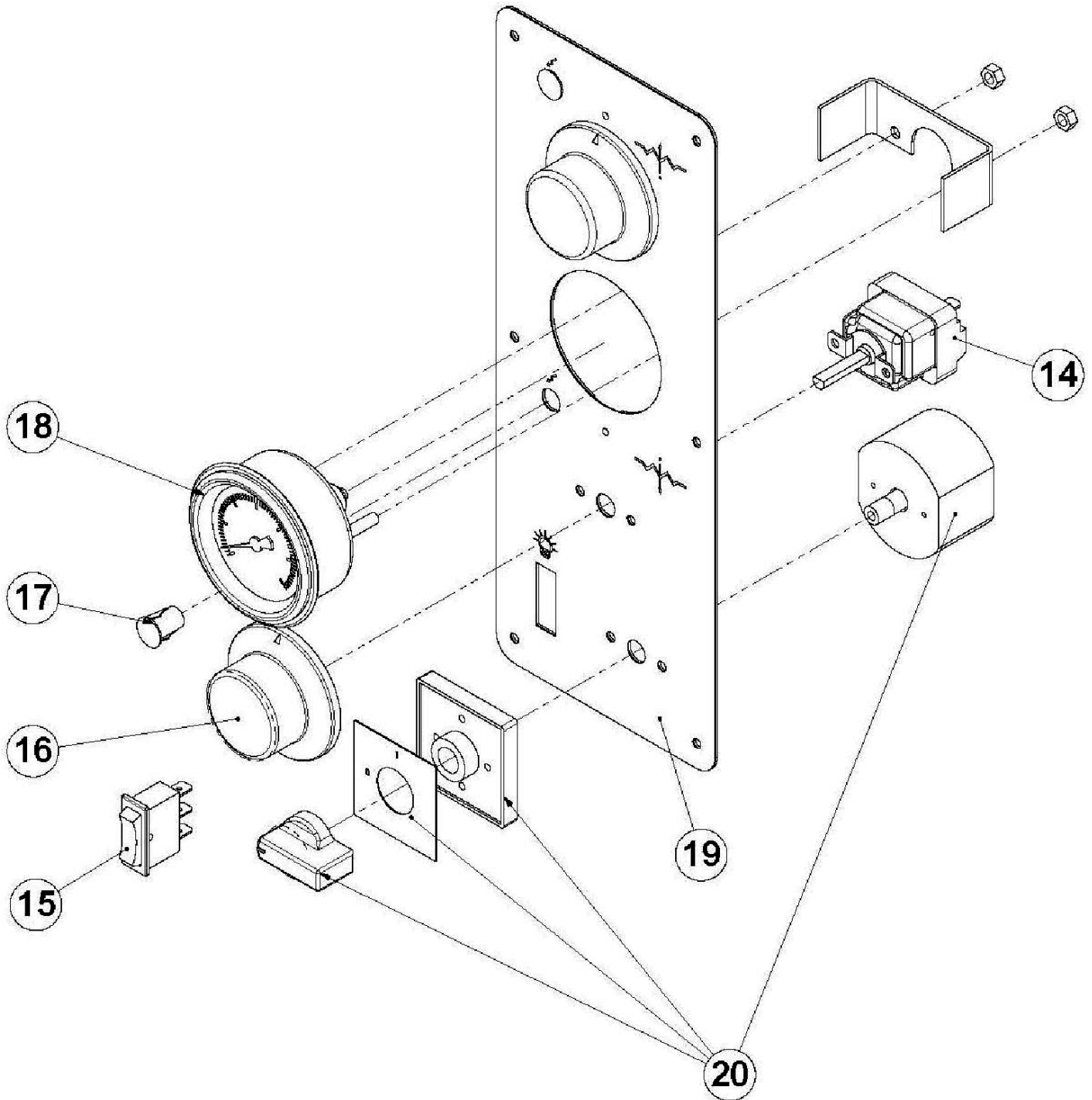

Parts Breakdown

Model PE-IT-0019-S 40635

Item No.	Description	Position	Item No.	Description	Position	Item No.	Description	Position
76602	Entry LH Side Panel for ENTRY MAX 4	1	76612	Resistor 2800 W 230 V Prime for ENTRY MAX 4	6	76646	Thermostat Knob AP10 Scale 0-10 for ENTRY MAX 4	16
76603	Entry RH Side Panel for ENTRY MAX 4	2	76614	Spheric Knob PLX.30-M8-C9 for ENTRY MAX 4	7	42848	Warning Light Lamp 380 V for ENTRY MAX 4	17
76604	Entry Complete Door for ENTRY MAX 4	3	AC196	Rectangular Lamp Glass for ENTRY MAX 4	8	74749	Analogue Thermometer 0-500°C for ENTRY MAX 4	18
76605	Entry Door Assembly for ENTRY MAX 4	3.1	42831	Mammut Assembly for ENTRY MAX 4	9	76626	Entry Control Label for ENTRY MAX 4	19
76606	Counterdoor Assembly for ENTRY MAX 4	3.2	AC197	Lamp Holder for ENTRY MAX 4	10	42035	Four-Pole Switch 16A for ENTRY MAX 4	20
76607	Elesa Handle I 280/115 for ENTRY MAX 4	3.3	74855	Lamp 12VAC 20W - G4 for ENTRY MAX 4	11	42849	Resin Coated Label PizzaGroup for ENTRY MAX 4	22
41771	Entry Glass Ceramic Plate for ENTRY MAX 4	3.4	74747	Cable Gland OBO 106 PG 21 for ENTRY MAX 4	12	42837	Equipotential Connection for ENTRY MAX 4	27
76609	Joint Entry for ENTRY MAX 4	3.5	74746	Nut for Cable Gland OBO 106 PG 11 for ENTRY MAX 4	13	AC291	Transformer 230 VAC-12VAC	29, 30
76650	Hollow Tile 350x700x14 for ENTRY MAX 4	4	AC198	Single-Phase Thermostat Tmax=400° for ENTRY MAX 4	14			
76612	Resistor 2800 W 230 V Prime for ENTRY MAX 4	5	42048	Red Single-Pole Switch for ENTRY MAX 4	15			

Model PE-IT-0038-D 40636

Item No.	Description	Position	Item No.	Description	Position	Item No.	Description	Position
77228	Entry LH Side Panel for ENTRY MAX 8	1	76612	Resistor 2800 W 230 V Prime for ENTRY MAX 8	6	76646	Thermostat Knob AP10 Scale 0-10 for ENTRY MAX 8	16
77229	Entry RH Side Panel for ENTRY MAX 8	2	76614	Spheric Knob PLX.30-M8-C9 for ENTRY MAX 8	7	42848	Warning Light Lamp 380 V for ENTRY MAX 8	17
76604	Entry Complete Door for ENTRY MAX 8	3	AC196	Rectangular Lamp Glass for ENTRY MAX 8	8	74749	Analogue Thermometer 0-500°C for ENTRY MAX 8	18
76605	Entry Door Assembly for ENTRY MAX 8	3.1	42831	Mammut Assembly for ENTRY MAX 8	9	76626	Entry Control Label for ENTRY MAX 8	19
76606	Counterdoor Assembly for ENTRY MAX 8	3.2	AC197	Lamp Holder for ENTRY MAX 8	10	42035	Four-Pole Switch 16A for ENTRY MAX 8	20
76607	Elesa Handle I 280/115 for ENTRY MAX 8	3.3	74855	Lamp 12VAC 20W - G4 for ENTRY MAX 8	11	42849	Resin Coated Label PizzaGroup for ENTRY MAX 8	22
41771	Entry Glass Ceramic Plate for ENTRY MAX 8	3.4	74747	Cable Gland OBO 106 PG 21 for ENTRY MAX 8	12	42837	Equipotential Connection for ENTRY MAX 8	27
76609	Joint Entry for ENTRY MAX 8	3.5	74746	Nut for Cable Gland OBO 106 PG 11 for ENTRY MAX 8	13	AC291	Transformer 230 VAC-12VAC	29, 30
76650	Hollow Tile 350x700x14 for ENTRY MAX 8	4	AC198	Single-Phase Thermostat Tmax=400° for ENTRY MAX 8	14			
76612	Resistor 2800 W 230 V Prime for ENTRY MAX 8	5	42048	Red Single-Pole Switch for ENTRY MAX 8	15			

Electrical Schematics

Model PE-IT-0019-S 40635

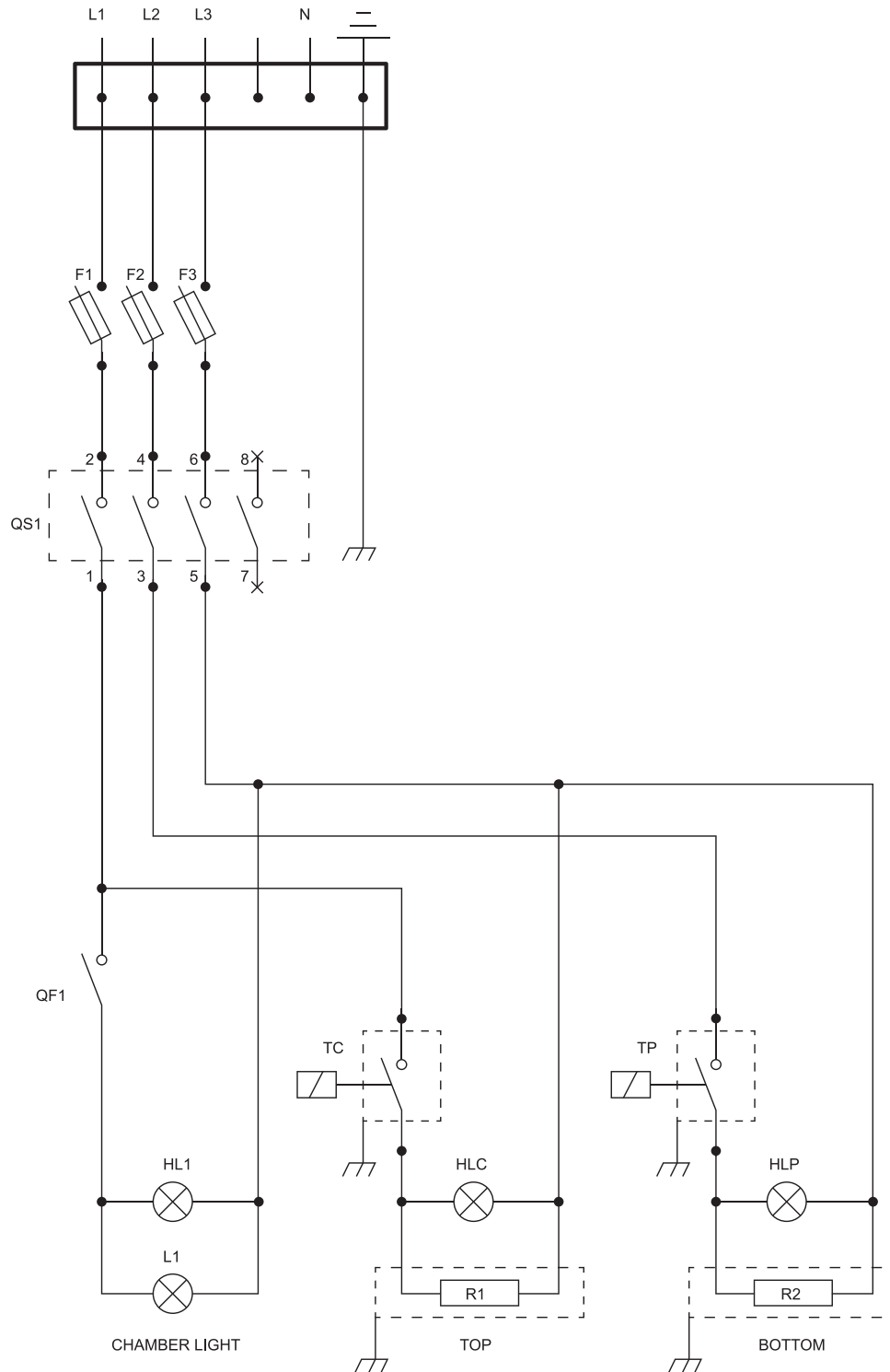

Electrical Schematics

Model PE-IT-0038-D 40636

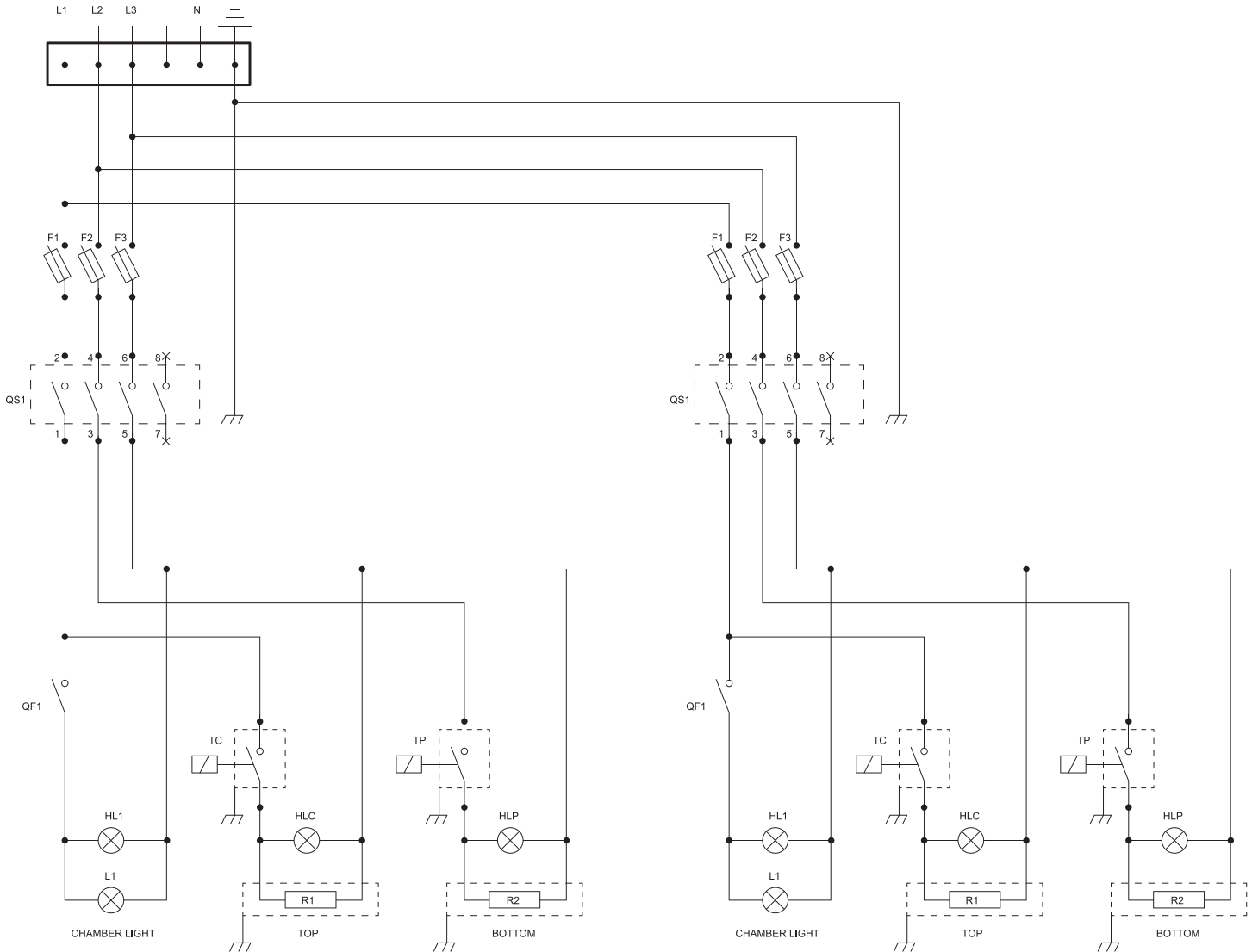



Warranty Registration

Thank you for purchasing an Omcan product. To register your warranty for this product, complete the information below, tear off the card at the perforation and then send to the address specified below. You can also register online by visiting:

Merci d'avoir acheté un produit Omcan. Pour enregistrer votre garantie pour ce produit, complétez les informations ci-dessous, détachez la carte au niveau de la perforation, puis l'envoyer à l'adresse spécifiée ci-dessous. Vous pouvez également vous inscrire en ligne en visitant:

Gracias por comprar un producto Omcan usted. Para registrar su garantía para este producto, complete la información a continuación, cortar la tarjeta en la perforación y luego enviarlo a la dirección indicada a continuación. También puede registrarse en línea en:

<https://omcan.com/warranty-registration/>

For mailing in Canada

Pour postale au Canada

Por correo en Canadá

OMCAN

PRODUCT WARRANTY REGISTRATION

3115 Pepper Mill Court,

Mississauga, Ontario

Canada, L5L 4X5

For mailing in the US

Pour diffusion aux États-Unis

Por correo en los EE.UU.

OMCAN

PRODUCT WARRANTY REGISTRATION

4450 Witmer Industrial Estates, Unit 4,

Niagara Falls, New York

USA, 14305

or email to: service@omcan.com



Purchaser's Information

Name: _____

Address: _____

City: _____ Province or State: _____ Postal or Zip: _____

Country: _____

Dealer from which Purchased: _____

Dealer City: _____ Dealer Province or State: _____

Invoice: _____

Model Name: _____ Model Number: _____

Machine Description: _____

Date of Purchase (MM/DD/YYYY): _____

Would you like to extend the warranty? Yes No

Company Name: _____

Telephone: _____

Email Address: _____

Type of Company:

Restaurant Bakery Deli

Butcher Supermarket Caterer

Institution (specify): _____

Other (specify): _____

Serial Number: _____

Date of Installation (MM/DD/YYYY): _____

Thank you for choosing Omcan | Merci d'avoir choisi Omcan | Gracias por elegir Omcan



Since 1951 Omcan has grown to become a leading distributor of equipment and supplies to the North American food service industry. Our success over these many years can be attributed to our commitment to strengthen and develop new and existing relationships with our valued customers and manufacturers. Today with partners in North America, Europe, Asia and South America, we continually work to improve and grow the company. We strive to offer customers exceptional value through our qualified local sales and service representatives who provide convenient access to over 5,000 globally sourced products.

Depuis 1951 Omcan a grandi pour devenir un des “leaders” de la distribution des équipements et matériel pour l’industrie des services alimentaires en Amérique du Nord. Notre succès au cours de ces nombreuses années peut être attribué à notre engagement à renforcer et à développer de nouvelles et existantes relations avec nos clients et les fabricants de valeur. Aujourd’hui avec des partenaires en Amérique du Nord, Europe, Asie et Amérique du Sud, nous travaillons continuellement à améliorer et développer l’entreprise. Nous nous efforçons d’offrir à nos clients une valeur exceptionnelle grâce à nos ventes locales qualifiées et des représentants de service qui offrent un accès facile à plus de 5000 produits provenant du monde entier.

Desde 1951 Omcan ha crecido hasta convertirse en un líder en la distribución de equipos y suministros de alimentos en América del Norte industria de servicios. Nuestro éxito en estos años se puede atribuir a nuestro compromiso de fortalecer y desarrollar nuevas relaciones existentes con nuestros valiosos clientes y fabricantes. Hoy con socios de América del Norte, Europa, Asia y América del Sur, que trabajan continuamente para mejorar y crecer la empresa. Nos esforzamos por ofrecer a nuestros clientes valor excepcional a través de nuestro local de ventas y representantes de los servicios que proporcionan un fácil acceso a más de 5,000 productos con origen a nivel mundial.

