



***Vacuum Packaging Machines***  
***Model VP-IT-0330***  
***Item 14407***  
***Instruction Manual***



**STOP**  
**DO NOT RETURN**  
**THIS PRODUCT TO THE STORE**

For questions or assistance with this product call OMCAN Toll Free:  
1 800 465 0234  
Customer Service  
or  
visit the Support section of  
[www.omcan.com](http://www.omcan.com)

*Revised - 12/05/2019*

Toll Free: 1-800-465-0234  
Fax: 905-607-0234  
Email: [service@omcan.com](mailto:service@omcan.com)  
[www.omcan.com](http://www.omcan.com)

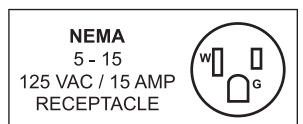

# ***Table of Contents***

Model VP-IT-0330

---

<b>Section</b>	<b>Page</b>
General Information -----	3 - 4
Safety and Warranty -----	4 - 6
Technical Specifications -----	6
Installation -----	6
Operation -----	6 - 7
Maintenance -----	7 - 8
Parts Breakdown -----	8 - 9
Electrical Schematics -----	10
Warranty Registration -----	11



# General Information

---

Omcan Manufacturing and Distributing Company Inc., Food Machinery of America, Inc. dba Omcan and Omcan Inc. are not responsible for any harm or injury caused due to any person's improper or negligent use of this equipment. The product shall only be operated by someone over the age of 18, of sound mind, and not under the influence of any drugs or alcohol, who has been trained in the correct operation of this machine, and is wearing authorized, proper safety clothing. Any modification to the machine voids any warranty, and may cause harm to individuals using the machine or in the vicinity of the machine while in operation.

## CHECK PACKAGE UPON ARRIVAL

Upon receipt of an Omcan shipment please inspect for external damage. If no damage is evident on the external packaging, open carton to ensure all ordered items are within the box, and there is no concealed damage to the machine. If the package has suffered rough handling, bumps or damage (visible or concealed), please note it on the bill of lading before accepting the delivery and contact Omcan within 24 hours, so we may initiate a claim with the carrier. A detailed report on the extent of the damage caused to the machine must be filled out within three days, from the delivery date shown in the shipping documents. Omcan has no recourse for damaged products that were shipped collect or third party.

**Before operating any equipment, always read and familiarize yourself with all operation and safety instructions.**

Omcan would like to thank you for purchasing this machine. It's of the utmost importance to save these instructions for future reference. Also save the original box and packaging for shipping the equipment if servicing or returning of the machine is required.

---

Omcan Fabrication et distribution Compañie Limité et Food Machinery d'Amérique, dba Omcan et Omcan Inc. ne sont pas responsables de tout dommage ou blessure causé du fait que toute personne ait utilisé cet équipement de façon irrégulière. Le produit ne doit être exploité que par quelqu'un de plus de 18 ans, saine d'esprit, et pas sous l'influence d'une drogue ou d'alcool, qui a été formé pour utiliser cette machine correctement, et est vêtu de vêtements de sécurité approprié. Toute modification de la machine annule toute garantie, et peut causer un préjudice à des personnes utilisant la machine ou des personnes à proximité de la machine pendant son fonctionnement.

## VÉRIFIEZ LE COLIS DÈS RÉCEPTION

Dès réception d'une expédition d'Omcan veuillez inspecter pour dommages externes. Si aucun dommage n'est visible sur l'emballage externe, ouvrez le carton afin de s'assurer que tous les éléments commandés sont dans la boîte, et il n'y a aucun dommage dissimulé à la machine. Si le colis n'a subi aucune mauvaises manipulations, de bosses ou de dommages (visible ou cachée), notez-le sur le bond de livraison avant d'accepter la livraison et contactez Omcan dans les 24 heures qui suivent, pour que nous puissions engager une réclamation auprès du transporteur. Un rapport détaillé sur l'étendue des dommages causés à la machine doit être rempli dans un délai de trois jours, à compter de la date de livraison indiquée dans les documents d'expédition. Omcan n'a aucun droit de recours pour les produits endommagés qui ont été expédiés ou cueilli par un tiers transporteur.

# General Information

---

Avant d'utiliser n'importe quel équipement, toujours lire et vous familiariser avec toutes les opérations et les consignes de sécurité.

Omcan voudrais vous remercier d'avoir choisi cette machine. Il est primordial de conserver ces instructions pour une référence ultérieure. Également conservez la boîte originale et l'emballage pour l'expédition de l'équipement si l'entretien ou le retour de la machine est nécessaire.

---

Omcan Empresa De Fabricacion Y Distribucion Inc. Y Maquinaria De Alimentos De America, Inc. dba Omcan y Omcan Inc. no son responsables de ningun daño o perjuicio causado por cualquier persona inadecuada o el uso descuidado de este equipo. El producto solo podra ser operado por una persona mayor de 18 años, en su sano juicio y no bajo alguna influencia de droga o alcohol, y que este ha sido entrenado en el correcto funcionamiento de esta máquina, y ésta usando ropa apropiada y autorizada. Cualquier modificación a la máquina anula la garantía y puede causar daños a las personas usando la máquina mientras esta en el funcionamiento.

## REVISE EL PAQUETE A SU LLEGADA

Tras la recepcion de un envio Omcan favor inspeccionar daños externos. Si no hay daños evidentes en el empaque exterior, Habra el carton para asegurarse que todos los articulos solicitados estén dentro de la caja y no encuentre daños ocultos en la máquina. Si el paquete ha sufrido un manejo de poco cuidado, golpes o daños (visible o oculto) por favor anote en la factura antes de aceptar la entrega y contacte Omcan dentro de las 24 horas, de modo que podamos iniciar una reclamación con la compañía. Un informe detallado sobre los daños causados a la máquina debe ser llenado en el plazo de tres días, desde la fecha de entrega que se muestra en los documentos de envío. Omcan no tiene ningun recurso por productos dañados que se enviaron a recoger por terceros.

Antes de utilizar cualquier equipo, siempre leer y familiarizarse con todas las instrucciones de operación y seguridad.

Omcan quisiera darles las gracias por la compra de esta máquina. Es de la máxima importancia para guardar estas instrucciones para referencias en el futuro. También guarde la caja original y el embalaje para envío del equipo si el mantenimiento o la devolución de la máquina es necesaria.

# Safety and Warranty

---

## PAY ATTENTION TO WORK SAFETY:

ELECTRICAL EQUIPMENT CAN CAUSE HARM TO PERSONS. IT IS THE RESPONSIBILITY OF THE USER TO INSTALL THIS APPLIANCE ONLY AFTER HE HAS READ THIS MANUAL WITH CARE AND BECOME FAMILIAR WITH ALL NECESSARY REQUIREMENTS.

## WARNING

Welding and cooling times must be adjusted depending on the thickness of the bag that is used greater



# Safety and Warranty

---

thicknesses require longer times and vice versa. The time required to aspirate all the air and generate a vacuum depends on the relationship between the dimensions of the bag and the quantity of product it contains. Every time there is liquid inside the plate seal or inside the cup these must be immediately cleaned and dried. Presence of liquid, in fact, may prevent perfect vacuum seal. In this case we recommend repeating the weld one centimeter back from the first weld. Avoid putting materials in the bags that may puncture the bag during aspiration phases.

## **IMPORTANT**

THE MANUFACTURER DECLINES ALL RESPONSIBILITY FOR HARM TO PERSONS, ANIMALS OR PROPERTY CAUSED BY FAILURE TO COMPLY, TOTALLY OR IN PART WITH THE INSTALLATION, OPERATING AND MAINTENANCE INSTRUCTIONS GIVEN ABOVE.

## **CE STATEMENT OF CONFORMITY AND MACHINE SAFETY STANDARDS**

The CE statement of conformity is the process whereby the manufacturer or his agent residing in the European Community states that the machine placed on the market complies with all the basic health and safety requirements that concern it. Signing the CE statement of conformity authorizes the manufacturer or his agent residing in the European Community to put the CE brand on the machine (1). The manufacturer, in particular, guarantees: The machines are designed to operate, be adjusted and undergo maintenance without these procedures, performed in the conditions herein stipulated, exposing persons to risks; The manufacturer has applied the following principles, in the order given, when selecting the most appropriate solutions: reduce or eliminate risks in the best possible manner (integrate safety in design and manufacture of the machine); adopt the necessary protection measures regarding risks that cannot be eliminated - inform users regarding residual risks caused by incomplete efficiency of the safety measures adopted. The manufacturer, during design and manufacture of the machine as well as when drawing up operating instructions, has considered not only formal use of the machine but also all reasonably possible uses (2). (1)From CE Machine Regulations, Attachment V, European Community Official Publications Office, 1993, Luxembourg.) From CEN/TC 114-EN 292 machine Safety Standards. The Ce machine conformity Statement (Directive 8 9/392 Ce, Attachment II, part A) - The model - MT 500 - vacuum packaging machine - conforms to the terms of Machine Directive (Directive 89/392 CE) as emended and to the national legislation that enacts it and also states that the following (parts of clauses of) harmonization standards have been applied: en 60204-1, CEN/EN 71, CEN/TC 114,CE 88/378, ATS 2486.

## **1 YEAR PARTS AND LABOUR BENCH WARRANTY**

**Within the warranty period, contact Omcan Inc. at 1-800-465-0234 to schedule a drop off to either an Omcan authorized service depot in the area, or to an Omcan Service warehouse to repair the equipment.**

**Unauthorized maintenance will void the warranty. Warranty covers electrical and part failures, not improper use.**

**Please see <https://omcan.com/disclaimer> for complete info.**

## **WARNING:**

The packaging components (cardboard, polyethylene, and others) are classified as normal solid urban waste

# Safety and Warranty

---

and can therefore be disposed of without difficulty.

In any case, for suitable recycling, we suggest disposing of the products separately (differentiated waste) according to the current norms.

**DO NOT DISCARD ANY PACKAGING MATERIALS IN THE ENVIRONMENT!**

# Technical Specifications

---

<b>Model</b>	<b>VP-IT-0330</b>
<b>Type</b>	Seal Bar 13"/ 330mm
<b>Cycle Time</b>	20-30 sec
<b>Electrical</b>	110V / 60Hz / 1
<b>Weight</b>	10 lbs. / 4.5 kgs.
<b>Packaging Weight</b>	13 lbs. / 5.9 kgs.
<b>Dimensions</b>	14.5" x 12" x 6" / 368 x 305 x 150mm
<b>Packaging Dimensions</b>	16" x 14" x 7" / 406 x 356 x 178mm
<b>Item Number</b>	14407

# Installation

---

Set the sealer on a stable horizontal surface. Make sure ventilation is not blocked by any obstacle. Check that the operating voltage for the unit corresponds to available grid voltage. Also check that the plug has a ground connection since this appliance has insulation and is equipped with a device for connection to the safety ground conductor in accordance with the provisions for class 1 appliances (CEI 64 8 Standards) and must be firmly connected to ground. The power outlet must be able to furnish at least 110 V of power.

# Operation

---

Set sealing timer on number four (4). Insert the product into a large bag. Lift the mobile cover. Position the mouth of the bag one (1) centimeter beyond the black seal. Lower the cover and press the pump push-button, putting pressure downwards so that the needle on the vacuum gauge goes past position 0.2. When the vacuum is made and the vacuum gauge needle has stabilized, then press sealing push-button and wait until the vacuum pump automatically turns off.

# Operation

## RECOMMENDATIONS

The bag must be the right size for the product to be contained. Adjust the sealing timer based on the thickness of the bag. The thicker the bag, the more sealing time is needed. Removing the blood will be faster/slower depending on the proportions between the product and thickness of the bag. Blood may need to be removed with certain types of meat. This blood will not get inside the pump but stops inside the seal which must be cleaned. If liquid is removed, then re-seal the bag right below the sealing you have just made. If there are wrinkles along the sealing the re-seal the bag as above. Before sealing the bag, stretch it out with your hands to eliminate any air bubbles. Use care when packaging meat with bones as they can puncture the bag.

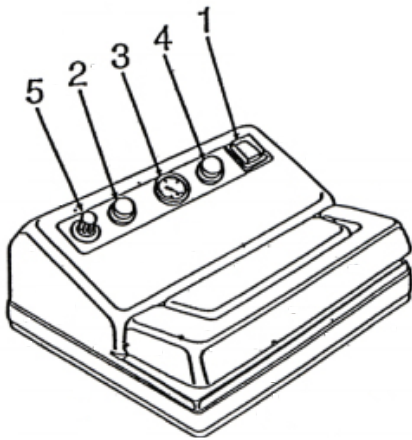

1. General Cut-out Switch
2. Pump Push Button
3. Vacuum gauge
4. Welding push button
5. Welding timer

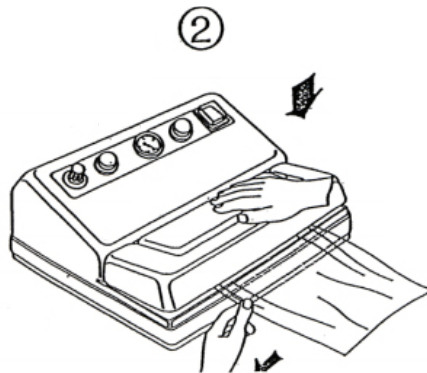
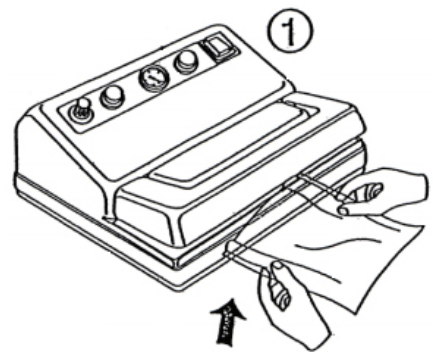

## Maintenance

All maintenance must be done with the machine off and the power plug disconnected from the power outlet. The machine must remain off for at least 20 minutes so that all welding components cool down. The following maintenance procedures can be performed safely if you comply with these precautions every day, or whenever necessary. Clean exterior components, seals, the filter, etc. using alcohol detergent. Parts that are cleaned must be perfectly dried before restarting the appliance. Eliminate all foreign bodies that prevent free air circulation in the air aspiration tubes. The welding bar cover strip has an average working life of about 2000 welds. Replace this cover strip when necessary.

# Maintenance

## REFERENCE

Item Number	Model Number	Description	Manufacturer Model Number
14407	VP-IT-0330	Vacuum Packaging Machine 13" / 330mm Seal Bar 110V/60/1	MT500

# Parts Breakdown

## Model VP-IT-0330 14407

Item No.	Description	Position	Item No.	Description	Position	Item No.	Description	Position
16552	Potentiometer for MT500	1	<a href="#">16556</a>	Silicon Bar for MT500	11	16563	Base for MT500	21
16553	Time Regulator Knob for MT500	2	16557	Non-Stick Coating for MT500	12	39093	Rubber Feet for MT500	22
16554	Push Button for MT500	3, 5	16559	Element for MT500	14	39094	Draft Tube for MT500	23
17779	Vacuum Gauge for MT500	4	16560	Upper Cover for MT500	15	16564	Rubber Joint for MT500	24
39088	Main On - Off Switch for MT500	6	39090	Filter for MT500	16	16565	Vacuum Pump for MT500	25
17780	Pin for MT500	7	16561	Fuse for MT500	17	39095	Internal Cables for MT500	26
17781	Hinge for MT500	8	16562	Electronic Board for MT500	18	<a href="#">16566</a>	Foam Gasket for MT500	27
39089	Chamber Cover for MT500	9	39091	Transformer for MT500	19	23826	Valve Kit for MT500	
19928	Chamber Fixed and Mobile Surfaces for MT500	10, 13	39092	Power Supply Cable for MT500	20			

# Parts Breakdown

Model VP-IT-0330 14407

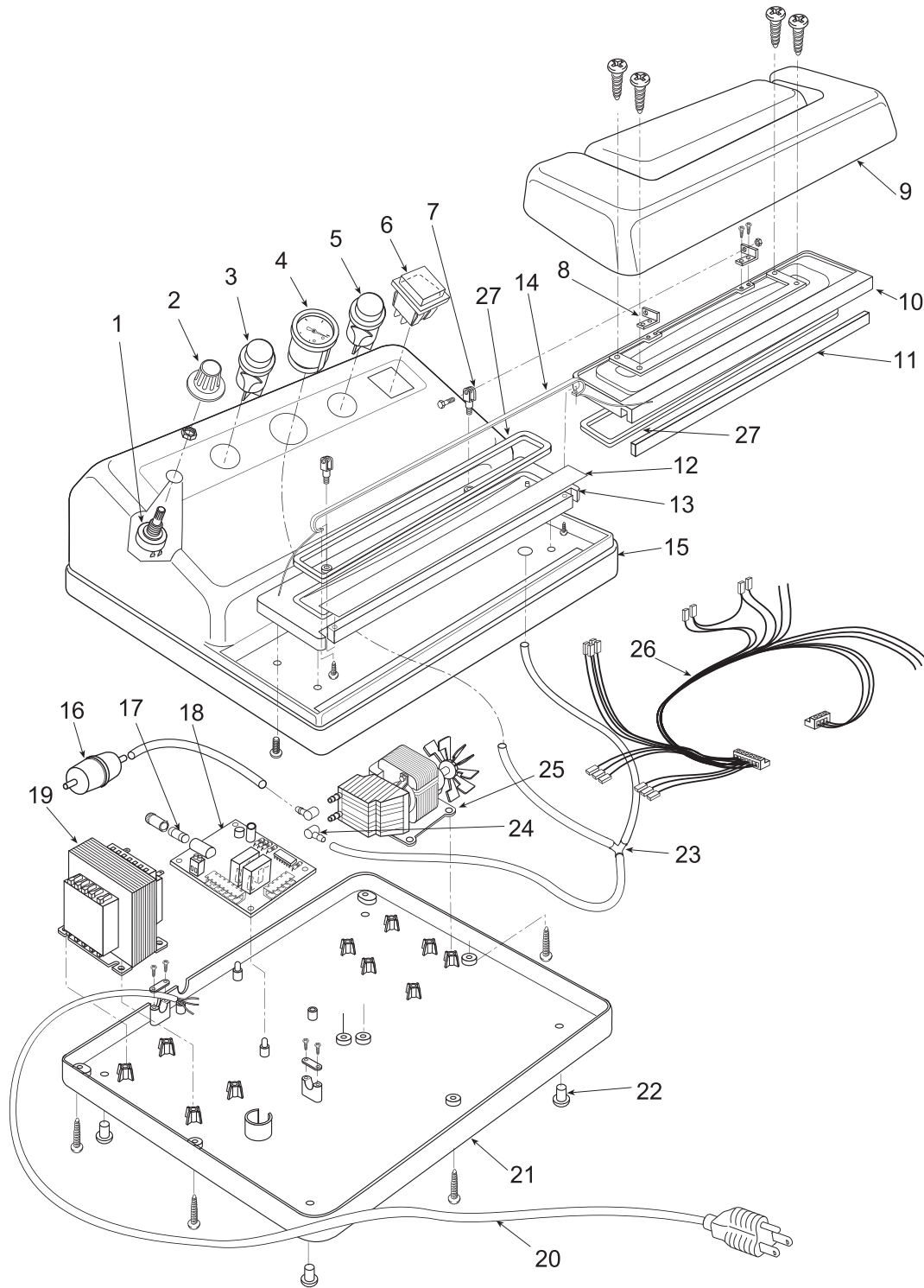

# Electrical Schematics

## Model VP-IT-0330 14407

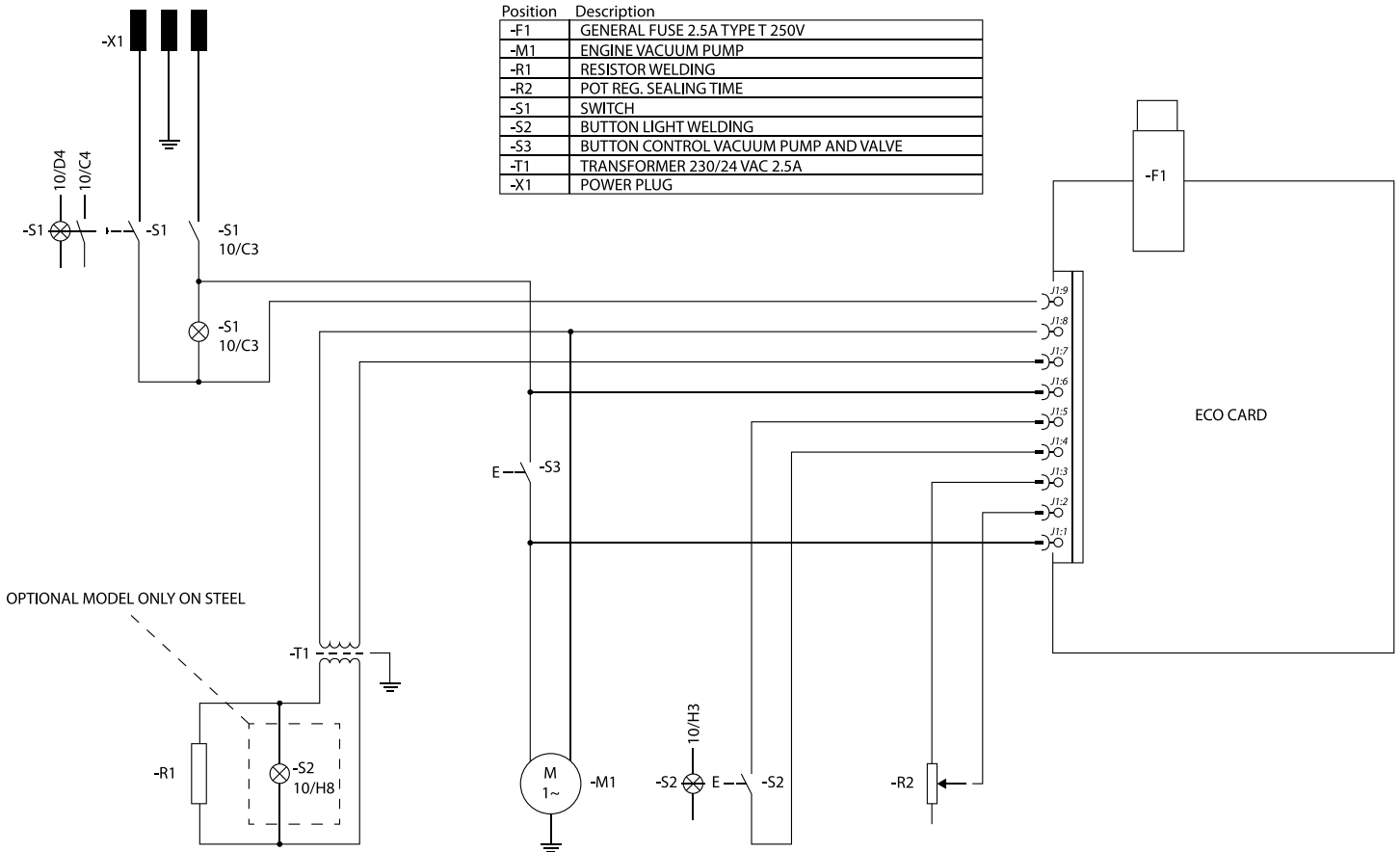



# Warranty Registration

Thank you for purchasing an Omcan product. To register your warranty for this product, complete the information below, tear off the card at the perforation and then send to the address specified below. You can also register online by visiting:

Merci d'avoir acheté un produit Omcan. Pour enregistrer votre garantie pour ce produit, complétez les informations ci-dessous, détachez la carte au niveau de la perforation, puis l'envoyer à l'adresse spécifiée ci-dessous. Vous pouvez également vous inscrire en ligne en visitant:

Gracias por comprar un producto Omcan usted. Para registrar su garantía para este producto, complete la información a continuación, cortar la tarjeta en la perforación y luego enviarlo a la dirección indicada a continuación. También puede registrarse en línea en:

<https://omcan.com/warranty-registration/>

For mailing in Canada

Pour postale au Canada

Por correo en Canadá

**OMCAN**

PRODUCT WARRANTY REGISTRATION

3115 Pepper Mill Court,

Mississauga, Ontario

Canada, L5L 4X5

For mailing in the US

Pour diffusion aux États-Unis

Por correo en los EE.UU.

**OMCAN**

PRODUCT WARRANTY REGISTRATION

4450 Witmer Industrial Estates, Unit 4,

Niagara Falls, New York

USA, 14305

*or email to: [service@omcan.com](mailto:service@omcan.com)*



Purchaser's Information

Name: \_\_\_\_\_

Address: \_\_\_\_\_

City: \_\_\_\_\_ Province or State: \_\_\_\_\_ Postal or Zip: \_\_\_\_\_

Country: \_\_\_\_\_

Dealer from which Purchased: \_\_\_\_\_

Dealer City: \_\_\_\_\_ Dealer Province or State: \_\_\_\_\_

Invoice: \_\_\_\_\_

Model Name: \_\_\_\_\_ Model Number: \_\_\_\_\_

Machine Description: \_\_\_\_\_

Date of Purchase (MM/DD/YYYY): \_\_\_\_\_

Would you like to extend the warranty?  Yes  No

Company Name: \_\_\_\_\_

Telephone: \_\_\_\_\_

Email Address: \_\_\_\_\_

Type of Company:

Restaurant  Bakery  Deli

Butcher  Supermarket  Caterer

Institution (specify): \_\_\_\_\_

Other (specify): \_\_\_\_\_

Serial Number: \_\_\_\_\_

Date of Installation (MM/DD/YYYY): \_\_\_\_\_

**Thank you for choosing Omcan | Merci d'avoir choisi Omcan | Gracias por elegir Omcan**



Since 1951 Omcan has grown to become a leading distributor of equipment and supplies to the North American food service industry. Our success over these many years can be attributed to our commitment to strengthen and develop new and existing relationships with our valued customers and manufacturers. Today with partners in North America, Europe, Asia and South America, we continually work to improve and grow the company. We strive to offer customers exceptional value through our qualified local sales and service representatives who provide convenient access to over 5,000 globally sourced products.

---

Depuis 1951 Omcan a grandi pour devenir un des “leaders” de la distribution des équipements et matériel pour l’industrie des services alimentaires en Amérique du Nord. Notre succès au cours de ces nombreuses années peut être attribué à notre engagement à renforcer et à développer de nouvelles et existantes relations avec nos clients et les fabricants de valeur. Aujourd’hui avec des partenaires en Amérique du Nord, Europe, Asie et Amérique du Sud, nous travaillons continuellement à améliorer et développer l’entreprise. Nous nous efforçons d’offrir à nos clients une valeur exceptionnelle grâce à nos ventes locales qualifiées et des représentants de service qui offrent un accès facile à plus de 5000 produits provenant du monde entier.

---

Desde 1951 Omcan ha crecido hasta convertirse en un líder en la distribución de equipos y suministros de alimentos en América del Norte industria de servicios. Nuestro éxito en estos años se puede atribuir a nuestro compromiso de fortalecer y desarrollar nuevas relaciones existentes con nuestros valiosos clientes y fabricantes. Hoy con socios de América del Norte, Europa, Asia y América del Sur, que trabajan continuamente para mejorar y crecer la empresa. Nos esforzamos por ofrecer a nuestros clientes valor excepcional a través de nuestro local de ventas y representantes de los servicios que proporcionan un fácil acceso a más de 5,000 productos con origen a nivel mundial.

