

# Service Manual

Digital Camera

LUMIX  HDMI

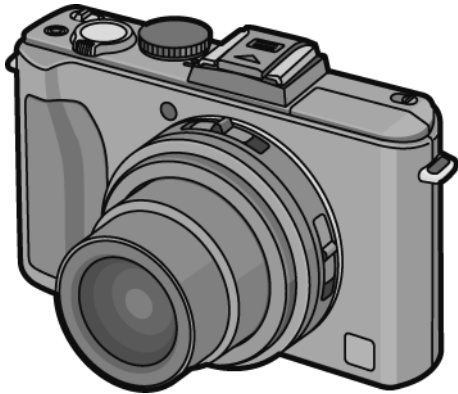

Model No. **DMC-LX5P**  
**DMC-LX5PC**  
**DMC-LX5PU**  
**DMC-LX5EB**  
**DMC-LX5EE**  
**DMC-LX5EF**  
**DMC-LX5EG**  
**DMC-LX5EP**  
**DMC-LX5GC**  
**DMC-LX5GD**  
**DMC-LX5GK**  
**DMC-LX5GN**  
**DMC-LX5GT**  
**DMC-LX5SG**

Vol. 1

Colour

(K).....Black Type

(W).....White Type (only P/GC/GD/GK/GN/GT)

## WARNING

This service information is designed for experienced repair technicians only and is not designed for use by the general public. It does not contain warnings or cautions to advise non-technical individuals of potential dangers in attempting to service a product. Products powered by electricity should be serviced or repaired only by experienced professional technicians. Any attempt to service or repair the product or products dealt with in this service information by anyone else could result in serious injury or death.

**Panasonic**<sup>®</sup>

© Panasonic Corporation 2010 Unauthorized copying and distribution is a violation of law.

# TABLE OF CONTENTS

|   | PAGE      | PAGE |
|---|-----------|------|
| <b>1 Safety Precautions</b> .....   | <b>3</b>  |      |
| 1.1. General Guidelines .....   | 3         |      |
| 1.2. Leakage Current Cold Check .....   | 3         |      |
| 1.3. Leakage Current Hot Check (See Figure 1.) .....  | 3         |      |
| 1.4. How to Discharge the E.Capacitor on Flash<br>P.C.B. ....   | 4         |      |
| <b>2 Warning</b> .....  | <b>5</b>  |      |
| 2.1. Prevention of Electrostatic Discharge (ESD)<br>to Electrostatically Sensitive (ES) Devices ..... | 5         |      |
| 2.2. How to Recycle the Lithium Ion Battery (U.S.<br>Only) .....                                      | 5         |      |
| 2.3. Caution for AC Cord(For EB/GC) .....   | 6         |      |
| 2.4. How to Replace the Lithium Battery .....   | 7         |      |
| <b>3 Service Navigation</b> .....   | <b>8</b>  |      |
| 3.1. Introduction .....   | 8         |      |
| 3.2. About lens block .....   | 8         |      |
| 3.3. Note: When replacement FeRAM(IC6003) on<br>the main P.C.B. ....                                  | 8         |      |
| 3.4. General Description About Lead Free Solder<br>(PbF) .....  | 8         |      |
| 3.5. Important Notice 1:(Other than U.S.A. and<br>Canadian Market) .....                              | 8         |      |
| 3.6. How to Define the Model Suffix (NTSC or PAL<br>model) .....                                      | 9         |      |
| <b>4 Specifications</b> .....   | <b>13</b> |      |
| <b>5 Location of Controls and Components</b> .....  | <b>14</b> |      |
| <b>6 Service Mode</b> .....   | <b>16</b> |      |
| 6.1. Error Code Memory Function .....   | 16        |      |
| 6.2. ICS (Indication of additional Camera Settings<br>when picture was taken) function .....          | 18        |      |
| <b>7 Service Fixture &amp; Tools</b> .....  | <b>20</b> |      |
| 7.1. Service Fixture and Tools .....  | 20        |      |
| 7.2. When Replacing the Main P.C.B. ....  | 21        |      |
| 7.3. Service Position .....   | 21        |      |
| <b>8 Disassembly and Assembly Instructions</b> .....  | <b>22</b> |      |
| 8.1. Disassembly Flow Chart .....   | 22        |      |
| 8.2. P.C.B. Location .....  | 22        |      |
| 8.3. Disassembly Procedure .....  | 23        |      |
| 8.4. Lens Disassembly Procedure .....   | 33        |      |
| 8.5. Assembly Procedure for the Lens .....  | 36        |      |
| 8.6. Removal of the CCD Unit .....  | 40        |      |
| 8.7. Removal of the Focus Motor .....   | 41        |      |
| 8.8. The Application of Grease Method .....   | 41        |      |
| <b>9 Measurements and Adjustments</b> .....   | <b>42</b> |      |
| 9.1. Introduction .....   | 42        |      |
| 9.2. Before Disassembling the unit .....  | 42        |      |
| 9.3. Details of Electrical Adjustment .....   | 44        |      |
| 9.4. After Adjustment .....   | 48        |      |
| <b>10 Maintenance</b> .....   | <b>49</b> |      |
| 10.1. Cleaning Lens and LCD Panel .....   | 49        |      |

# 1 Safety Precautions

## 1.1. General Guidelines

### 1. IMPORTANT SAFETY NOTICE

There are special components used in this equipment which are important for safety. These parts are marked by

 in the Schematic Diagrams, Circuit Board Layout, Exploded Views and Replacement Parts List. It is essential that these critical parts should be replaced with manufacturer's specified parts to prevent X-RADIATION, shock, fire, or other hazards. Do not modify the original design without permission of manufacturer.

2. An Isolation Transformer should always be used during the servicing of AC Adaptor whose chassis is not isolated from the AC power line. Use a transformer of adequate power rating as this protects the technician from accidents resulting in personal injury from electrical shocks. It will also protect AC Adaptor from being damaged by accidental shorting that may occur during servicing.
3. When servicing, observe the original lead dress. If a short circuit is found, replace all parts which have been overheated or damaged by the short circuit.
4. After servicing, see to it that all the protective devices such as insulation barriers, insulation papers shields are properly installed.
5. After servicing, make the following leakage current checks to prevent the customer from being exposed to shock hazards.

## 1.2. Leakage Current Cold Check

1. Unplug the AC cord and connect a jumper between the two prongs on the plug.
2. Measure the resistance value, with an ohmmeter, between the jumpered AC plug and each exposed metallic cabinet part on the equipment such as screwheads, connectors, control shafts, etc. When the exposed metallic part has a return path to the chassis, the reading should be between  $1\text{ M}\Omega$  and  $5.2\text{ M}\Omega$ . When the exposed metal does not have a return path to the chassis, the reading must be infinity.

## 1.3. Leakage Current Hot Check (See Figure 1.)

1. Plug the AC cord directly into the AC outlet. Do not use an isolation transformer for this check.
2. Connect a  $1.5\text{ k}\Omega$ ,  $10\text{ W}$  resistor, in parallel with a  $0.15\text{ }\mu\text{F}$  capacitor, between each exposed metallic part on the set and a good earth ground, as shown in Figure 1.
3. Use an AC voltmeter, with  $1\text{ k}\Omega/\text{V}$  or more sensitivity, to measure the potential across the resistor.
4. Check each exposed metallic part, and measure the voltage at each point.
5. Reverse the AC plug in the AC outlet and repeat each of the above measurements.
6. The potential at any point should not exceed  $0.75\text{ V RMS}$ . A leakage current tester (Simpson Model 229 or equivalent) may be used to make the hot checks, leakage current must not exceed  $1/2\text{ mA}$ . In case a measurement is outside of the limits specified, there is a possibility of a shock hazard, and the equipment should be repaired and rechecked before it is returned to the customer.

Hot-Check Circuit

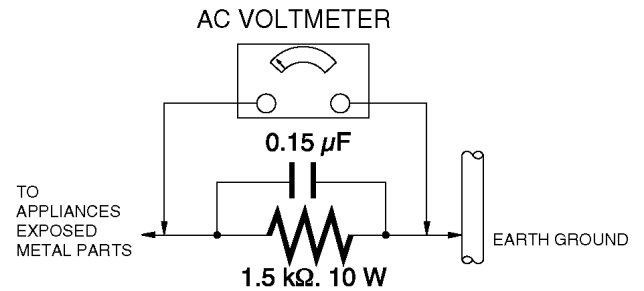

Figure. 1

## 1.4. How to Discharge the E.Capacitor on Flash P.C.B.

### CAUTION:

1. Be sure to discharge the E.capacitor on FLASH P.C.B..
2. Be careful of the high voltage circuit on FLASH P.C.B. when servicing.

### [Discharging Procedure]

1. Refer to the disassemble procedure and remove the necessary parts/unit.
2. Install the insulation tube onto the lead part of resistor (ERG5SJ102:1k $\Omega$  /5W).  
(an equivalent type of resistor may be used.)
3. Place a resistor between both terminals of E.capacitor on the FLASH P.C.B. for approx. 5 seconds.
4. After discharging, confirm that the E.capacitor voltage is lower than 10V using a voltmeter.

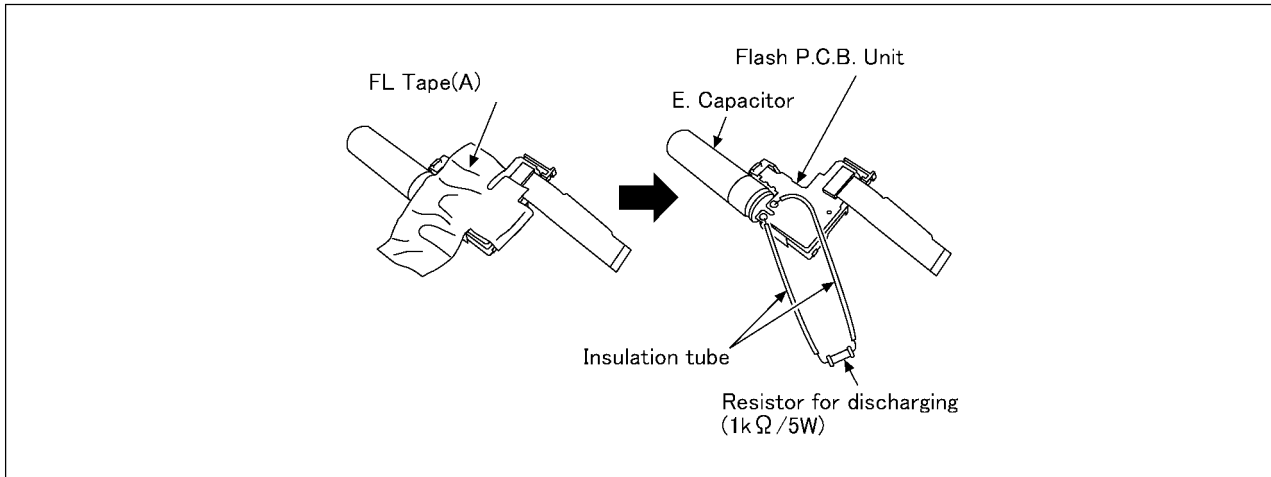

Fig. F1

## 2 Warning

### 2.1. Prevention of Electrostatic Discharge (ESD) to Electrostatically Sensitive (ES) Devices

Some semiconductor (solid state) devices can be damaged easily by static electricity. Such components commonly are called Electrostatically Sensitive (ES) Devices.

Examples of typical ES devices are CCD image sensor, IC (integrated circuits) and some field-effect transistors and semiconductor "chip" components.

The following techniques should be used to help reduce the incidence of component damage caused by electrostatic discharge (ESD).

1. Immediately before handling any semiconductor component or semiconductor-equipped assembly, drain off any ESD on your body by touching a known earth ground. Alternatively, obtain and wear a commercially available discharging ESD wrist strap, which should be removed for potential shock reasons prior to applying power to the unit under test.
2. After removing an electrical assembly equipped with ES devices, place the assembly on a conductive surface such as aluminum foil, to prevent electrostatic charge buildup or exposure of the assembly.
3. Use only a grounded-tip soldering iron to solder or unsolder ES devices.
4. Use only an antistatic solder removal device. Some solder removal devices not classified as "antistatic (ESD protected)" can generate electrical charge sufficient to damage ES devices.
5. Do not use freon-propelled chemicals. These can generate electrical charges sufficient to damage ES devices.
6. Do not remove a replacement ES device from its protective package until immediately before you are ready to install it. (Most replacement ES devices are packaged with leads electrically shorted together by conductive foam, aluminum foil or comparable conductive material).
7. Immediately before removing the protective material from the leads of a replacement ES device, touch the protective material to the chassis or circuit assembly into which the device will be installed.

**CAUTION :**

Be sure no power is applied to the chassis or circuit, and observe all other safety precautions.

8. Minimize bodily motions when handling unpackaged replacement ES devices. (Otherwise harmless motion such as the brushing together of your clothes fabric or the lifting of your foot from a carpeted floor can generate static electricity (ESD) sufficient to damage an ES device).

### 2.2. How to Recycle the Lithium Ion Battery (U.S. Only)

**ENGLISH**



A lithium ion battery that is recyclable powers the product you have purchased. Please call 1-800-8-BATTERY for information on how to recycle this battery.

**FRANÇAIS**



L'appareil que vous vous êtes procuré est alimenté par une batterie au lithium-ion recyclable. Pour des renseignements sur le recyclage de la batterie, veuillez composer le 1-800-8-BATTERY.

## 2.3. Caution for AC Cord (For EB/GC)

### 2.3.1. Information for Your Safety

#### IMPORTANT

Your attention is drawn to the fact that recording of pre-recorded tapes or discs or other published or broadcast material may infringe copyright laws.

#### WARNING

To reduce the risk of fire or shock hazard, do not expose this equipment to rain or moisture.

#### CAUTION

To reduce the risk of fire or shock hazard and annoying interference, use the recommended accessories only.

#### FOR YOUR SAFETY

##### DO NOT REMOVE THE OUTER COVER

To prevent electric shock, do not remove the cover. No user serviceable parts inside. Refer servicing to qualified service personnel.

### 2.3.2. Caution for AC Mains Lead

For your safety, please read the following text carefully.

This appliance is supplied with a moulded three-pin mains plug for your safety and convenience.

A 5-ampere fuse is fitted in this plug.

Should the fuse need to be replaced please ensure that the replacement fuse has a rating of 5 amperes and it is approved by ASTA or BSI to BS1362

Check for the ASTA mark or the BSI mark on the body of the fuse.



If the plug contains a removable fuse cover you must ensure that it is refitted when the fuse is replaced.

If you lose the fuse cover, the plug must not be used until a replacement cover is obtained.

A replacement fuse cover can be purchased from your local Panasonic Dealer.

If the fitted moulded plug is unsuitable for the socket outlet in your home then the fuse should be removed and the plug cut off and disposed of safely.

There is a danger of severe electrical shock if the cut off plug is inserted into any 13-ampere socket.

If a new plug is to be fitted please observe the wiring code as shown below.

If in any doubt, please consult a qualified electrician.

### 2.3.2.1. Important

The wires in this mains lead are coloured in accordance with the following code:

|       |         |
|-------|---------|
| Blue  | Neutral |
| Brown | Live    |

As the colours of the wires in the mains lead of this appliance may not correspond with the coloured markings identifying the terminals in your plug, proceed as follows:

The wire which is coloured BLUE must be connected to the terminal in the plug which is marked with the letter N or coloured BLACK.

The wire which is coloured BROWN must be connected to the terminal in the plug which is marked with the letter L or coloured RED.

Under no circumstances should either of these wires be connected to the earth terminal of the three pin plug, marked with the letter E or the Earth Symbol.

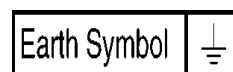

### 2.3.2.2. Before Use

Remove the Connector Cover as follows.

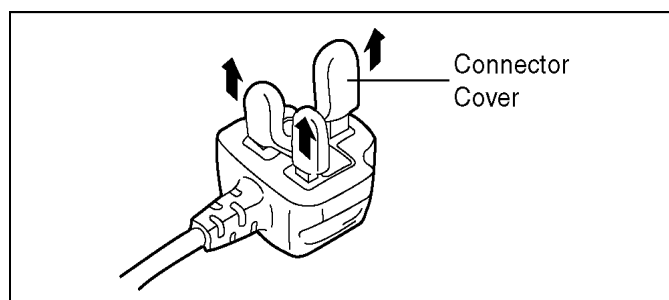

### 2.3.2.3. How to Replace the Fuse

1. Remove the Fuse Cover with a screwdriver.

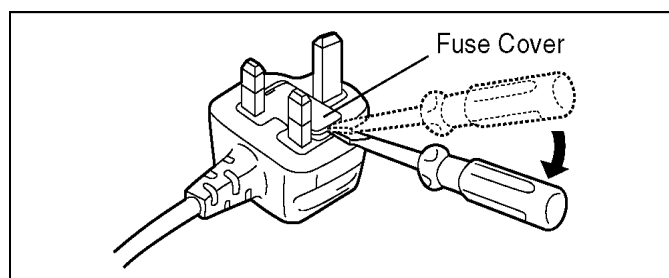

2. Replace the fuse and attach the Fuse cover.

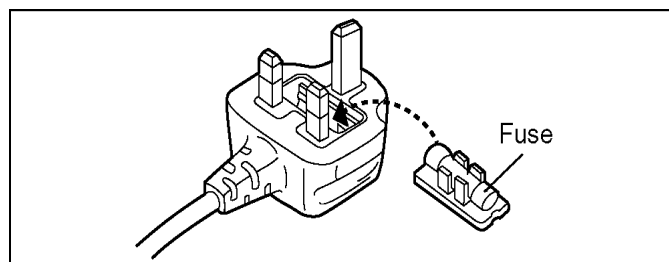

## 2.4. How to Replace the Lithium Battery

### 2.4.1. Replacement Procedure

1. Remove the BATTERY P.C.B.. (Refer to Disassembly Procedures.)
2. Remove the Lithium battery (Ref. No. "B9201" at foil side of BATTERY P.C.B.) and then replace it into new one.

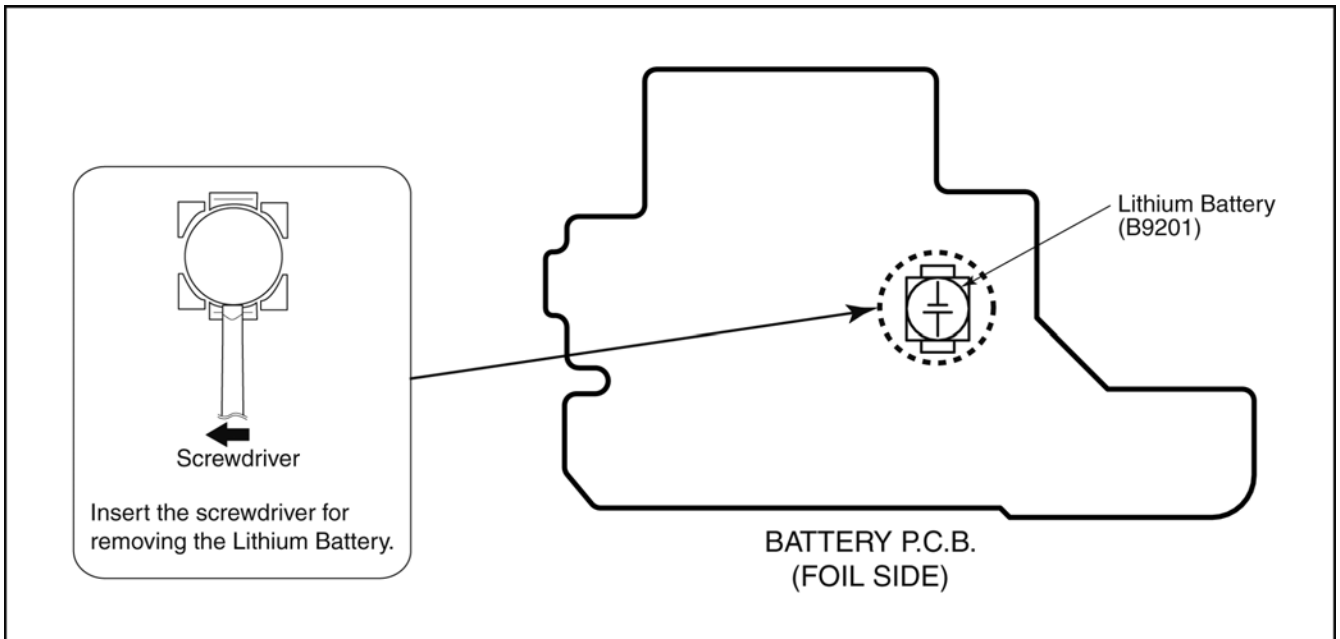

#### NOTE:

This Lithium battery is a critical component.

(Type No.: ML421 **Manufactured by Energy Company, Panasonic Corporation.**)

It must never be subjected to excessive heat or discharge.

It must therefore only be fitted in requirement designed specifically for its use.

Replacement batteries must be of same type and manufacture.

They must be fitted in the same manner and location as the original battery, with the correct polarity contacts observed.

Do not attempt to re-charge the old battery or re-use it for any other purpose.

It should be disposed of in waste products destined for burial rather than incineration.

#### (For English)

### CAUTION

Danger of explosion if battery is incorrectly replaced.

Replace only with the same or equivalent type recommended by the manufacturer.

Dispose of used batteries according to the manufacturer's instructions.

#### (For German)

### ACHTUNG

Explosionsgefahr bei falschem Anbringen der Batterie. Ersetzen Sie nur mit einem äquivalentem vom Hersteller empfohlenem Typ.

Behandeln Sie gebrauchte Batterien nach den Anweisungen des Herstellers.

#### (For French)

### MISE EN GARDE

Une batterie de remplacement inappropriée peut exploser. Ne remplacez qu'avec une batterie identique ou d'un type recommandé par le fabricant. L'élimination des batteries usées doit être faite conformément aux instructions du fabricant.

#### NOTE:

Above caution is applicable for a battery pack which is for DMC-LX5 series, as well.

## 3 Service Navigation

### 3.1. Introduction

This service manual contains technical information, which allow service personnel's to understand and service this model.

Please place orders using the parts list and not the drawing reference numbers.

If the circuit is changed or modified, the information will be followed by service manual to be controlled with original service manual.

### 3.2. About lens block

- The image sensor (CCD) unit which are connected to the lens unit with 3 screws. These screws are locked with the screw locking glue, after performing the Optical tilt adjustment.
- During servicing, if one of CCD fixing screws are loosened or removed, the Optical tilt adjustment must be performed. About the Optical tilt adjustment, refer to the "9.3.2 Adjustment Specifications" for details.

### 3.3. Note: When replacement FeRAM(IC6003) on the main P.C.B.

- After replacing the FeRAM(IC6003), it is necessary to use the adjustment software "DIAS" and "Adjustment Boot Software" to allow the "Initialization".
- These software are available at "TSN Website". To download, click on "Support Information from NDBG/VDBG-AVC".

### 3.4. General Description About Lead Free Solder (PbF)

The lead free solder has been used in the mounting process of all electrical components on the printed circuit boards used for this equipment in considering the globally environmental conservation.

The normal solder is the alloy of tin (Sn) and lead (Pb). On the other hand, the lead free solder is the alloy mainly consists of tin (Sn), silver (Ag) and Copper (Cu), and the melting point of the lead free solder is higher approx.30°C (86°F) more than that of the normal solder.

**Distinction of P.C.B. Lead Free Solder being used**

|  |
|--|
| The letter of "PbF" is printed either foil side or components side on the P.C.B. using the lead free solder.(See right figure) |
|--|

|     |
|-----|
| PbF |
|-----|

#### Service caution for repair work using Lead Free Solder (PbF)

- The lead free solder has to be used when repairing the equipment for which the lead free solder is used.  
(Definition: The letter of "PbF" is printed on the P.C.B. using the lead free solder.)
- To put lead free solder, it should be well molten and mixed with the original lead free solder.
- Remove the remaining lead free solder on the P.C.B. cleanly for soldering of the new IC.
- Since the melting point of the lead free solder is higher than that of the normal lead solder, it takes the longer time to melt the lead free solder.
- Use the soldering iron (more than 70W) equipped with the temperature control after setting the temperature at 350±30°C (662±86°F).

#### Recommended Lead Free Solder (Service Parts Route.)

- The following 3 types of lead free solder are available through the service parts route.  
RFKZ03D01KS------(0.3mm 100g Reel)  
RFKZ06D01KS------(0.6mm 100g Reel)  
RFKZ10D01KS------(1.0mm 100g Reel)

#### Note

\* Ingredient: tin (Sn) 96.5%, silver (Ag) 3.0%, Copper (Cu) 0.5%, Cobalt (Co) / Germanium (Ge) 0.1 to 0.3%

### 3.5. Important Notice 1:(Other than U.S.A. and Canadian Market)

1. The service manual does not contain the following information because of issues servicing to component level without necessary equipment/facilities.
  - a. Schematic diagram, Block Diagram and P.C.B. layout of MAIN P.C.B..
  - b. Parts list for individual parts for MAIN P.C.B..When a part replacement is required for repairing MAIN P.C.B., replace as an assembled parts. (MAIN P.C.B.)
2. The following category is/are recycle module part. please send it/them to Central Repair Center.
  - MAIN P.C.B. (VEP56112A: P/PC/PU/EE/GC/GD/GK/GN/GT/SG)
  - MAIN P.C.B. (VEP56112B: EB/EF/EG/EP)

### 3.6. How to Define the Model Suffix (NTSC or PAL model)







There are nine kinds of DMC-LX5, regardless of the colours.

- a) DMC-LX5 (Japan domestic model), DMC-LX5SG
- b) DMC-LX5P/PC
- c) DMC-LX5EB/EF/EG/EP
- d) DMC-LX5EE
- e) DMC-LX5GT
- f) DMC-LX5GK
- g) DMC-LX5GD
- h) DMC-LX5GN
- i) DMC-LX5GC/PU

What is the difference is that the "INITIAL SETTINGS" data which is stored in Flash-ROM mounted on MAIN P.C.B..

#### 3.6.1. Defining methods:

To define the model suffix to be serviced, refer to the nameplate which is putted on the bottom side of the Unit.

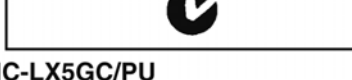
|  |
|--|
| <p><b>a) DMC-LX5 (Japan domestic model), DMC-LX5SG</b><br/>The nameplate for these models show the following Safety registration mark.</p>  |
| <p><b>b) DMC-LX5P/PC</b><br/>The nameplate for these models show the following Safety registration mark.</p>                                |
| <p><b>c) DMC-LX5EB/EF/EG/EP</b><br/>The nameplate for these models show the following Safety registration mark.</p>                       |
| <p><b>d) DMC-LX5EE</b><br/>The nameplate for this model show the following Safety registration mark.</p>                                  |
| <p><b>e) DMC-LX5GT</b><br/>The nameplate for this model show the following Safety registration mark.</p>                                  |
| <p><b>f) DMC-LX5GK</b><br/>The nameplate for this model show the following Safety registration mark.</p>                                  |
| <p><b>g) DMC-LX5GD</b><br/>The nameplate for this model show the following Safety registration mark.</p>                                  |
| <p><b>h) DMC-LX5GN</b><br/>The nameplate for this model show the following Safety registration mark.</p>                                  |
| <p><b>i) DMC-LX5GC/PU</b><br/>The nameplate for these models do not show any above Safety registration mark.</p>   |

**NOTE:**

After replacing the MAIN P.C.B., be sure to achieve adjustment.

The service software is available at "TSN Website". To download, click on "Support Information from NWBG/VDBG-AVC".

### 3.6.2. INITIAL SETTINGS:

After replacing the MAIN P.C.B., be sure to perform the initial settings after achieving the adjustment by ordering the following procedure in accordance with model suffix of the unit.

#### 1. IMPORTANT NOTICE:

Before proceeding Initial settings, be sure to read the following CAUTIONS.

#### CAUTION 1:(INITIAL SETTINGS)

---AFTER REPLACING THE MAIN P.C.B. and/or FLASH-ROM ---

[Except "EG, EF, EB and EP" models : (VEP56112A is used as a Main P.C.B.)]

\*.The model suffix can be chosen **JUST ONE TIME.**

(Effective model suffix : " P/PU/GD/GC/GT/GK/EE/GN/PC/SG and NONE (JAPAN)")

\*.Once one of the model suffix has been chosen, the model suffix lists will not be displayed, thus, it can not be changed.

[Only for "EG, EF, EB and EP" models : (VEP56112B is used as a Main P.C.B.)]

\*.From the beginning, only "EG, EF, EB and EP" are displayed as model suffix lists, and these are displayed from the second times as well.

#### CAUTION 2:(Stored picture image data in the unit)

This unit employs "Built-in Memory" for picture image data recording.(Approx.40MB)  
After proceeding "INITIAL SETTINGS", the picture image data stored in the unit is erased.

#### 2. PROCEDURES:

• Precautions: Read the above "CAUTION 1" and "CAUTION 2", carefully.

• Preparation:

- Attach the Battery or AC Adaptor with a DC coupler to the unit.

(Since this unit has built-in memory, it can be performed without inserting SD memory card.)

• **Step 1. The temporary cancellation of "INITIAL SETTINGS":**

Set the mode dial to "[ P ] (Program AE mode)".

While keep pressing "[ UP ] of Cursor button" and [ MOTION PICTURE ] button simultaneously, turn the Power on.

• **Step 2. The cancellation of "INITIAL SETTINGS":**

Press the [ PLAYBACK ] button, then playback the picture.

Press "[ UP ] of Cursor button" and [ MOTION PICTURE ] button simultaneously, then turn the Power off.

• **Step 3. Turn the Power on:**

Set the mode dial to "[ P ] (Program AE mode)", and then turn the Power on.

• **Step 4. Display the INITIAL SETTING:**

While keep pressing [ MENU/SET ] and "[ RIGHT ] of Cursor buttons" simultaneously, turn the Power off.

The "INITIAL SETTINGS" menu is displayed.

There are two kinds of "INITIAL SETTINGS" menu form as follows:

[CASE 1. After replacing MAIN P.C.B.]

[Except "EG, EF, EB and EP" models: (VEP56112A is used as a Main P.C.B.)]

When MAIN P.C.B. has just been replaced, all of the model suffix is displayed as follows. (Three pages in total)



[Only "EG, EF, EB and EP" models: (VEP56112B is used as a Main P.C.B.)]

When MAIN P.C.B. has just been replaced, only 7 model suffix are displayed as follows. (Two pages in total)



[CASE 2. Other than "After replacing MAIN P.C.B."]



• **Step 5. Choose the model suffix in "INITIAL SETTINGS": (Refer to "CAUTION 1")**

**[Caution: After replacing MAIN P.C.B.]**

The model suffix can be chosen, **JUST ONE TIME**.

Once one of the model suffix have been chosen, the model suffix lists will not be displayed, thus, it can not be changed.

Therefore, select the area carefully.

Select the area with pressing "[ UP ] / [ DOWN ] of Cursor buttons".

• **Step 6. Set the model suffix in “INITIAL SETTINGS”:**

- Press the “[ RIGHT ] of Cursor buttons”.
- The only set area is displayed, and then press the “[ RIGHT ] of Cursor buttons” after confirmation.  
(The unit is powered off automatically.)

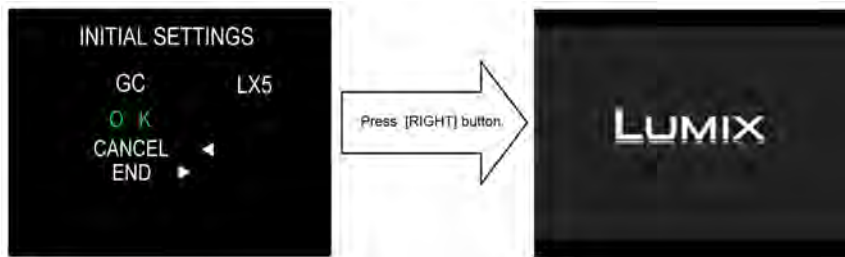

• **Step 7. CONFIRMATION:**

Confirm the display of “PLEASE SET THE CLOCK” in concerned language when the unit is turned on again.

When the unit is connected to PC with USB cable, it is detected as removable media.

(When the “GT” or “GK” model suffix is selected, the display shows “PLEASE SET THE CLOCK” in Chinese.)

1) As for your reference, major default setting condition is as shown in the following table.

• **Default setting (After “INITIAL SETTINGS”)**

|    | MODEL                          | VIDEO OUTPUT | LANGUAGE              | DATE            | REMARKS |
|----|--------------------------------|--------------|-----------------------|-----------------|---------|
| a) | DMC-LX5 (Japan domestic model) | NTSC         | Japanese              | Year/Month/Date |         |
| b) | DMC-LX5P                       | NTSC         | English               | Month/Date/Year |         |
| c) | DMC-LX5PU                      | NTSC         | Spanish               | Month/Date/Year |         |
| d) | DMC-LX5GD                      | NTSC         | Korean                | Year/Month/Date |         |
| e) | DMC-LX5GC                      | PAL          | English               | Date/Month/Year |         |
| f) | DMC-LX5GT                      | NTSC         | Chinese (traditional) | Year/Month/Date |         |
| g) | DMC-LX5GK                      | PAL          | Chinese (simplified)  | Year/Month/Date |         |
| h) | DMC-LX5EE                      | PAL          | Russian               | Date/Month/Year |         |
| i) | DMC-LX5GN                      | PAL          | English               | Date/Month/Year |         |
| j) | DMC-LX5PC                      | NTSC         | English               | Month/Date/Year |         |
| k) | DMC-LX5SG                      | PAL          | English               | Date/Month/Year |         |
| l) | DMC-LX5EG                      | PAL          | English               | Date/Month/Year |         |
| m) | DMC-LX5EF                      | PAL          | French                | Date/Month/Year |         |
| n) | DMC-LX5EB                      | PAL          | English               | Date/Month/Year |         |
| o) | DMC-LX5EP                      | PAL          | English               | Date/Month/Year |         |

# 4 Specifications

**Digital Camera:** Information for your safety

|                           |   |
|---------------------------|---|
| <b>Power Source:</b>      | DC 5.1 V  |
| <b>Power Consumption:</b> | 1.4 W (When recording)<br>0.8 W (When playing back) |

**Camera effective pixels:** 10,100,000 pixels  
**Image sensor:** 1/1.63" CCD, total pixel number 11,300,000 pixels, Primary color filter  
**Lens:** Optical 3.8×zoom, f=5.1 mm to 19.2 mm (35 mm film camera equivalent: 24 mm to 90 mm)/ F2.0 (Wide) to F3.3 (Tele)  
**Digital zoom:** Max. 4×  
**Extended optical zoom:** Max. 6.7× (When set to 3,000,000 pixels [3M] or less)  
**Focus range:** Normal: 50 cm (1.64 feet) to ∞  
 Macro/Intelligent Auto: 1 cm (0.04 feet) (Wide)/30 cm (0.99 feet) (Tele) to ∞  
 Scene Mode: There may be differences in the above settings.  
**Shutter system:** Electronic shutter + Mechanical shutter  
**Burst recording**  
**Burst speed:** Approx. 2.5 pictures/second  
**Number of recordable pictures:** Max. 5 pictures (Standard), max. 3 pictures (Fine).  
**Hi-speed burst**  
**Burst speed:** Approx. 10 pictures/second (Speed priority)  
 Approx. 6.5 pictures/second (Image priority)  
 [2.5M (1:1), 3M (4:3), 2.5M (3:2) or 2M (16:9) is selected as the picture size.]  
**Number of recordable pictures:** Approx. 15 to 100  
**Minimum illuminance:** Approx. 3 lx (when i-Low light is used)  
**Shutter speed:** 60 seconds to 1/4000th of a second  
 [STARRY SKY] Mode: 15 seconds, 30 seconds, 60 seconds  
**Exposure (AE):** Program AE (P)/Aperture-Priority AE (A)/Shutter-Priority AE (S)/Manual Exposure (M)  
 Exposure compensation (1/3 EV Step, -3 EV to +3 EV)  
 Multiple/Center weighted/Spot  
**Metering mode:** 3.0" TFT LCD (3:2)  
**LCD monitor:** (Approx. 460,000 dots) (field of view ratio about 100%)

**Flash:** Built-in pop up flash  
 Flash range: [ISO AUTO]  
 Approx. 80 cm (2.62 feet) to 7.2 m (23.6 feet) (Wide)  
**Microphone:** Monaural  
**Speaker:** Monaural  
**Recording media:** Built-in Memory (Approx. 40 MB)/SD Memory Card/SDHC Memory Card/SDXC Memory Card

**Recording file format**  
**Still Picture:** JPEG (based on "Design rule for Camera File system", based on "Exif 2.3" standard)/DPOF corresponding

**Motion pictures with audio:** AVCHD Lite/QuickTime Motion JPEG

**Interface**  
**Digital:** "USB 2.0" (High Speed)  
**Analog video/audio:** [for NTSC areas]  
 NTSC  
 Audio line output (monaural) [for PAL areas]  
 NTSC/PAL Composite (Switched by menu)  
 Audio line output (monaural)

**Terminal**  
**[AV OUT/DIGITAL]:** Dedicated jack (8 pin)  
**[HDMI]:** MiniHDMI TypeC  
**Dimensions:** Approx. 109.7 mm (W)×65.5 mm (H)×43.0 mm (D)  
 [4.32" (W)×2.58" (H)×1.69" (D)]  
 (excluding the projecting parts)  
**Mass (weight):** Approx. 271 g/0.6 lb (with card and battery)  
 Approx. 233 g/0.51 lb (excluding card and battery)

**Operating temperature:** 0 °C to 40 °C (32 °F to 104 °F)  
**Operating humidity:** 10%RH to 80%RH

**Battery Charger:** Information for your safety

|                |                                   |
|----------------|-----------------------------------|
| <b>Input:</b>  | ~ 110 V to 240 V, 50/60 Hz, 0.2 A |
| <b>Output:</b> | ===4.2 V, 0.65 A                  |

**Equipment mobility:** Movable

**Battery Pack (lithium-ion):** Information for your safety

|                          |                |
|--------------------------|----------------|
| <b>Voltage/capacity:</b> | 3.6 V/1250 mAh |
|--------------------------|----------------|

**NOTE:(Only for "EB/EF/EG/EP" models)**

- Data from the PC can not be written to the camera using the USB connection cable.

**Motion pictures**

**(Only "EB/EF/EG/EP" models:)**

- Motion pictures can be recorded continuously for up to 29 minutes 59 seconds.

**(Except "EB/EF/EG/EP" models:)**

- Motion picture recorded continuously in [MOTION JPEG] or [HIGH SPEED MOVIE] in Scene Mode is up to 2 GB. Only the maximum recordable time for 2 GB is displayed on the screen.

# 5 Location of Controls and Components

- 1 Lens
- 2 Self-timer indicator
- AF Assist Lamp
- 3 Flash
- 4 Shoulder strap eyelet
- 5 Focus selector switch

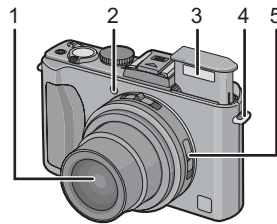

- 6 LCD monitor
- 7 [AF/AE LOCK] button
- 8 Playback button
- 9 Status indicator
- 10 [MENU/SET] button
- 11 [DISPLAY] button
- 12 [Q.MENU]/Delete button
- 13 Rear dial

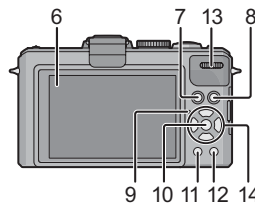

- 14 Cursor buttons
  - ▲/[FOCUS] button
  - ▼/Function button
 Assign Menu to ▼ button. It is convenient to register a Menu that is used often.  
 [FILM MODE]/[QUALITY]/[METERING MODE]/[WHITE BALANCE]/  
 [AF MODE]/[I.EXPOSURE]/[GUIDE LINE]/[REC AREA]/  
 [REMAINING DISP.]/[FLASH]/[AUTO BRACKET]/[ASPECT BRACKET]  
 ◀/Self-timer button  
 ▶/ISO

- 15 Aspect ratio selector switch
- 16 Microphone
- 17 Zoom lever
- 18 Motion picture button
- 19 Flash open switch
- 20 Hot shoe cover
  - Keep the hot shoe cover out of reach of children to prevent swallowing.
- 21 Mode dial
- 22 Shutter button
- 23 Camera ON/OFF switch
- 24 [HDMI] socket
- 25 [AV OUT/DIGITAL] socket
- 26 Lens ring front
- 27 Lens barrel

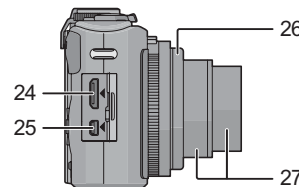
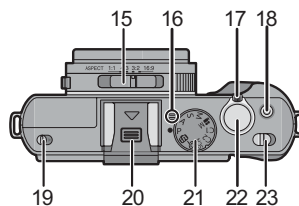

- 28 Tripod receptacle
  - When you use a tripod, make sure the tripod is stable when the camera is attached to it.
- 29 Speaker
  - Do not cover the speaker with your fingers.
- 30 Card/Battery door
- 31 Release lever
- 32 DC coupler cover
  - When using an AC adaptor, ensure that the Panasonic DC coupler and AC adaptor are used.
  - Always use a genuine Panasonic AC adaptor (optional).
  - We recommend you use a battery with sufficient battery power or the AC adaptor when recording motion pictures.
  - If while recording motion pictures using the AC adaptor and the power supply is cut off due to a power outage or if the AC adaptor is disconnected etc., the motion picture being recorded will not be recorded.

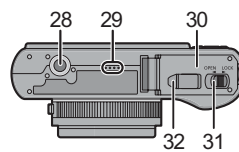

## Selecting the [REC] Mode

### 1 Turn the camera on.

(A) Mode dial

- The status indicator (2) lights when you turn this unit on (1). (It turns off after about 1 second.)

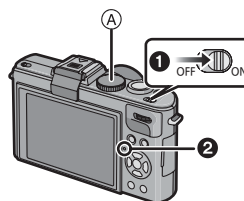

### 2 Switching the mode by rotating the mode dial.

Align a desired mode with part (B).

- Rotate the Mode dial slowly and surely to adjust to each mode. (The mode dial rotates 360°)

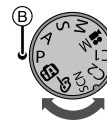

#### Basic

##### **P** Program AE Mode

The subjects are recorded using your own settings.

##### **iA** Intelligent Auto Mode

The subjects are recorded using settings automatically selected by the camera.

#### Advanced

##### **A** Aperture-Priority AE Mode

The shutter speed is automatically determined by the aperture value you set.

##### **S** Shutter-Priority AE Mode

The aperture value is automatically determined by the shutter speed you set.

##### **M** Manual Exposure Mode

The exposure is adjusted by the aperture value and the shutter speed which are manually adjusted.

##### **M** Creative Motion Picture Mode

Record motion picture with manual settings.

##### **C1 C2** Custom Mode

Use this mode to take pictures with previously registered settings.

##### **SCN** Scene Mode

This allows you to take pictures that match the scene being recorded.

##### **b** My Color Mode

Use this mode to check coloring effects, select a color mode from among twelve color modes, and then take pictures.

## About the Battery

- The camera has a function for distinguishing batteries which can be used safely. The dedicated battery supports this function. The only batteries suitable for use with this unit are genuine Panasonic products and batteries manufactured by other companies and certified by Panasonic. (Batteries which do not support this function cannot be used). Panasonic cannot in any way guarantee the quality, performance or safety of batteries which have been manufactured by other companies and are not genuine Panasonic products.

It has been found that counterfeit battery packs which look very similar to the genuine product are made available to purchase in some markets. Some of these battery packs are not adequately protected with internal protection to meet the requirements of appropriate safety standards. There is a possibility that these battery packs may lead to fire or explosion. Please be advised that we are not liable for any accident or failure occurring as a result of use of a counterfeit battery pack. To ensure that safe products are used we would recommend that a genuine Panasonic battery pack is used.

# 6 Service Mode

## 6.1. Error Code Memory Function

### 1. General description

This unit is equipped with history of error code memory function, and can be memorized 16 error codes in sequence from the latest. When the error is occurred more than 16, the oldest error is overwritten in sequence.

The error code is not memorized when the power supply is shut down forcibly (i.e., when the unit is powered on by the battery, the battery is pulled out) The error code is memorized to FLASH-ROM when the unit has just before powered off.

### 2. How to display

The error code can be displayed by ordering the following procedure:

#### • Preparation:

1. Attach the Battery or AC Adaptor with a DC coupler to the unit.

#### NOTE:

\*Since this unit has built-in memory, it can be performed without inserting SD memory card.

#### • Step 1. The temporary cancellation of "INITIAL SETTINGS":

Set the mode dial to "[ P ] (Program AE mode)".

While keep pressing "[ UP ] of Cursor button" and [ MOTION PICTURE ] button simultaneously, turn the Power on.

#### • Step 2. Execute the error code display mode:

Press the "[ LEFT ] of Cursor button", [ MENU/SET ] button and [ MOTION PICTURE ] button simultaneously.

The display is changed as shown below when the above buttons are pressed simultaneously.

Normal display → Error code display → Operation history display → Normal display → .....

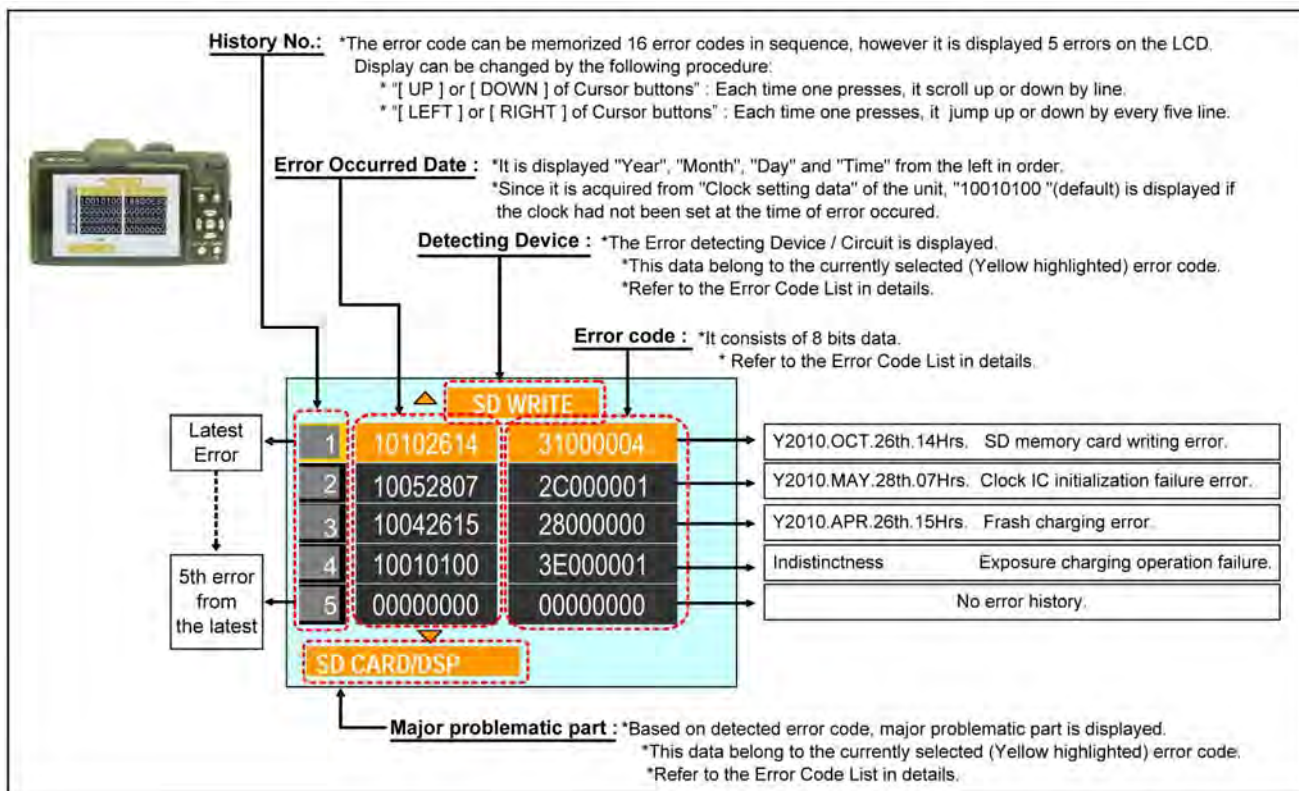

Example of Error Code Display

• 3. Error Code List

The error code consists of 8 bits data and it shows the following information.

| Attribute | Main item                                      | Sub item  | Error code  |   | Contents (Upper line)   |  | Error Indication   |  |  |   |  |                 |                 |
|-----------|--|---|---|---|---|--|--|--|--|---|--|-----------------|-----------------|
|           |  |   | High 4 bits   | Low 4 bits  | Problematic Part & Check point (Lower line)                             |  | Detecting device   | Problematic Part/Circuit                                       |  |   |  |                 |                 |
| LENS      | Lens drive                                     | OIS   | 18*0  | 1000  | PSD (X) error. Hall element (X axis) position detect error in OIS unit. | OIS Unit   | OIS X  | LENSu NG   |  |   |  |                 |                 |
|           |  |   |   | 2000  | PSD (Y) error. Hall element (Y axis) position detect error in OIS unit. | OIS Unit   | OIS Y  |  |  |   |  |                 |                 |
|           |  |   | 3000  | GYRO (X) error. Gyro (IC7301: X axis) detect error on MAIN P.C.B. | IC7301 (Gyro element) or IC6001 (VENUS FHD)                             | GYRO X   | GYRO NG  |  |  |   |  |                 |                 |
|           |  |   |   | 4000  | GYRO (Y) error. Gyro (IC7201: Y axis) detect error on MAIN P.C.B.       | IC7201 (Gyro element) or IC6001 (VENUS FHD)                          |  | GYRO Y   |  |   |  |                 |                 |
|           |  |   | 5000  | MREF error (Reference voltage error).                             | IC9101 (SYSTEM) or IC6001 (VENUS FHD)                                   | OIS REF  | LENSSd/DSP NG  |  |  |   |  |                 |                 |
|           |  |   |   | 6000  | Drive voltage (X) error.  | LENS Unit, LENS flex breaks, IC6001 (VENUS FHD) AD value error, etc. |  | OISX REF   |  |   |  |                 |                 |
|           |  |   | 7000  | Drive voltage (Y) error.  | LENS Unit, LENS flex breaks, IC6001 (VENUS FHD) AD value error, etc.    | OISY REF   | LENSu/LENS FPC   |  |  |   |  |                 |                 |
|           |  |   |   | Zoom  | 0710  | Collapsible barrel Low detect error                                  |  | (Collapsible barrel encoder always detects Low.)               | Mechanical lock, FP9005-(34) signal line or IC6001 (VENUS FHD) | ZOOM L  | ZOOMm/LENSu  |                 |                 |
|           |  |   | 0720  |   |   | Collapsible barrel High detect error                                 | (Collapsible barrel encoder always detects High.)                    | Mechanical lock, FP9005-(34) signal line or IC6001 (VENUS FHD) | ZOOM H   |   |  |                 |                 |
|           |  |   |   |   | 0730  | Zoom motor sensor error.   | Mechanical lock, FP9005-(41), (43) signal line or IC6001 (VENUS FHD) | ZOOM ENC   |  |   |  |                 |                 |
|           |  | 0740  | Zoom motor sensor error. (During monitor mode.)                 |   |   | Mechanical lock, FP9005-(41), (43) signal line or IC6001 (VENUS FHD) |  |  |  |   |  |                 |                 |
|           |  | 0750  | Zoom motor sensor error. (During monitor mode with slow speed.) |   | Mechanical lock, FP9005-(41), (43) signal line or IC6001 (VENUS FHD)    | ZOOM ENC   |  |  |  |   |  |                 |                 |
|           |  |   | Focus   |   | 0701  |  | HP High detect error   | (Focus encoder always detects High, and not becomes Low)       | Mechanical lock, FP9005-(34) signal line or IC6001 (VENUS FHD) | FOCUS L   |  | LENS FPC/DSP    |                 |
|           |  | 0702  |   |   | HP Low detect error   | (Focus encoder always detects Low, and not becomes High)             | Mechanical lock, FP9005-(34) signal line or IC6001 (VENUS FHD)       | FOCUS H  |  |   |  |                 |                 |
|           |  | Lens  | 18*1  | 0000  | Power ON time out error.  | LENS drive system  | LENS DRV   | LENSu  |  |   |  |                 |                 |
|           |  |   |   |   | 18*2  | Power OFF time out error.  |  |  | LENS drive system  |   |  |                 |                 |
|           |  | Adj. History  | OIS   | 19*0  | 2000  | OIS adj. Yaw direction amplitude error (small)                       | OIS ADJ  | OIS ADJ  |  |   |  |                 |                 |
|           |  |   |   |   | 3000  | OIS adj. Pitch direction amplitude error (small)                     |  |  |  |   |  |                 |                 |
|           |  |   |   |   | 4000  | OIS adj. Yaw direction amplitude error (large)                       |  |  |  |   |  |                 |                 |
|           |  |   |   |   | 5000  | OIS adj. Pitch direction amplitude error (large)                     |  |  |  |   |  |                 |                 |
|           | 6000   |   |   |   | OIS adj. MREF error   |  |  |  |  |   |  |                 |                 |
|           | 7000   |   |   |   | OIS adj. time out error   |  |  |  |  |   |  |                 |                 |
|           | 8000   |   |   |   | OIS adj. Yaw direction off set error                                    |  |  |  |  |   |  |                 |                 |
|           | 9000   |   |   |   | OIS adj. Pitch direction off set error                                  |  |  |  |  |   |  |                 |                 |
|           | A000   |   |   |   | OIS adj. Yaw direction gain error                                       |  |  |  |  |   |  |                 |                 |
|           | B000   |   |   |   | OIS adj. Pitch direction gain error                                     |  |  |  |  |   |  |                 |                 |
|           | C000   |   |   |   | OIS adj. Yaw direction position sensor error                            |  |  |  |  |   |  |                 |                 |
| D000      | OIS adj. Pitch direction position sensor error |   |   |   |   |  |  |  |  |   |  |                 |                 |
| E000      | OIS adj. other error                           |   |   |   |   |  |  |  |  |   |  |                 |                 |
| HARD      | VENUS A/D                                      |   |   |   | Flash   | 28*0   |  |  | 0000   | Flash charging error.                               | IC6001-(E18) signal line or Flash charging circuit | STRB CHG        | STRB PCB/FPC    |
|           | FLASH ROM (EEPROM Area)                        |   |   |   | FLASH ROM (EEPROM Area)   | 2B*0   |  |  | 0001   | EEPROM read error                                   | IC6001 (VENUS FHD)                                 | FROM RE         | FROM            |
|           |  |   |   |   |   |  |  |  | 0002   | EEPROM write error                                  | IC6001 (VENUS FHD)                                 | FROM WR         | FROM            |
|           |  |   |   |   |   |  |  |  | 0005   | Firmware version up error                           | Replace the firmware file in the SD memory card.   | (No indication) | (No indication) |
|           |  | 0008  | SDRAM error   | SDRAM Mounting defective  |   |  |  |  |  |   |  |                 |                 |
| SYSTEM    | RTC  | 2C*0  | 0001  | SYSTEM IC initialize failure error                                | Communication between IC6001 (VENUS FHD) and IC9101 (SYSTEM)            | SYS INIT   | MAIN PCB   |  |  |   |  |                 |                 |
| SOFT      | CPU  | Reset   | 30*0  | 0001  | NMI reset   | NMI RST  | MAIN PCB   |  |  |   |  |                 |                 |
|           |  |   |   | 0007  | Non Mask-able Interrupt (30000001-30000007 are caused by factors)       |  |  |  |  |   |  |                 |                 |
|           | Card   | Card  | 31*0  | 0001  | Card logic error  | SD CARD  | SD CARD/DSP  |  |  |   |  |                 |                 |
|           |  |   |   | 0002  | SD memory card data line or IC6001 (VENUS FHD)                          |  |  |  |  |   |  |                 |                 |
|           |  |   |   | 0004  | Card physical error   |  |  | SD memory card data line or IC6001 (VENUS FHD)                 |  |   |  |                 |                 |
|           |  |   |   | 0004  | Write error   |  |  | SD memory card data line or IC6001 (VENUS FHD)                 |  |   |  |                 |                 |
|           | CPU, ASIC hard                                 | Stop  | 38*0  | 0001  | Camera task finish process time out.                                    | LENS COM   | LENSu/DSP  |  |  |   |  |                 |                 |
|           |  |   |   |   | 0002  |  |  | Communication between Lens system and IC6001 (VENUS FHD)       |  |   |  |                 |                 |
|           |  |   |   | 0100  | Camera task invalid code error.   |  |  | IC6001 (VENUS FHD)   |  |   |  |                 |                 |
|           |  |   |   |   | 0200  |  |  |  | File time out error in recording motion image                  | IC6001 (VENUS FHD)                                  | DSP  | DSP             |                 |
|           |  |   |   | 0300  | File data cue send error in recording motion image                      |  |  | IC6001 (VENUS FHD)   |  |   |  |                 |                 |
|           |  |   |   |   | 0300  |  |  |  | Single or burst recording brake time out.                      |   |  |                 |                 |
|           |  |   |   | Memory area   | 3A*0  |  |  | 0008   | USB work area partitioning failure                             | USB dynamic memory securing failure when connecting | (No indication)                                    | (No indication) |                 |
|           | Operation                                      | Power on  | 3B*0  | 0000  | FLASHROM processing early period of camera during movement.             | INIT   | (No indication)  |  |  |   |  |                 |                 |
|           | Zoom   | Zoom  | 3C*0  | 0000  | Inperfect zoom lens processing  | ZOOM   | ZOOMm/LENSu  |  |  |   |  |                 |                 |
| Zoom lens |  |   |   |   |   |  |  |  |  |   |  |                 |                 |
| 35*0      |  |   |   | 0000  | Software error  |  |  | DSP  | DSP  |   |  |                 |                 |
|           |  |   |   | FFFF  | (0-7bit : command, 8-15bit : status)                                    |  |  |  |  |   |  |                 |                 |
| 35*1      | 0000   | Though record preprocessing is necessary, it is not called. | (No indication)   | (No indication)   |   |  |  |  |  |   |  |                 |                 |
|           |  | 35*2  |   |   | 0000  | Though record preprocessing is necessary, it is not completed.       |  |  |  |   |  |                 |                 |

### Important notice about "Error Code List"

#### 1) About "\*" indication:

The third digit from the left is different as follows.

- In case of 0 (example: 18001000)

When the third digit from the left shows "0", this error occurred under the condition of INITIAL SETTINGS has been completed.

It means that this error is occurred basically at user side.

- In case of 8 (example: 18801000)

When the third digit from the left shows "8", this error occurred under the condition of INITIAL SETTINGS has been released.

(Example; Factory assembling-line before unit shipment, Service mode etc.)

It means that this error is occurred at service side.

#### 2) About "?" indication: ("18\*0 0?01" to "18\*0 0?50"):

The third digit from the right shows one of the hexadecimal ("0" to "F") character.

#### • 4. How to exit from Error Code display mode:

Simply, turn the power off. (Since Error code display mode is executed under the condition of temporary cancellation of "INITIAL SETTINGS", it wake up with normal condition when turn off the power.)

##### NOTE:

The error code can not be initialized.

## 6.2. ICS (Indication of additional Camera Settings when picture was taken) function

### 1. General description

This unit is equipped with ICS (ICS: Indication of additional Camera Settings when picture was taken) function by playing back the concerned picture on the LCD display.

(This function is achieved by utilizing "maker note" data stored in Exif data area of recorded picture file.)

To proceed failure diagnosis, use this ICS function together with "displaying the recorded picture with picture information" function.

##### NOTE:

- The ICS function operates with a picture which is only taken with the same model. (It may not be displayed when the picture was taken with other model.)
- Since Exif data is not available after the picture is edited by PC, the ICS function may not be activated.

### 2. How to display

The ICS data is displayed by ordering the following procedure:

#### • Preparation:

1. Attach the Battery or AC Adaptor with a DC coupler to the unit.

##### NOTE:

Since this unit has built-in memory, it can be performed without inserting SD memory card.

#### • Step 1. The temporary cancellation of "INITIAL SETTINGS":

Set the mode dial to "[ P ] (Program AE mode)".

While keep pressing "[ UP ] of Cursor button" and [ MOTION PICTURE ] button simultaneously, turn the Power on.

#### • Step 2. Execute the ICS display mode:

Press the [ PLAYBACK ] button, then playback the picture.

Press the "[ LEFT ] of Cursor button", [ MENU/SET ] button and [ MOTION PICTURE ] button simultaneously.

Press the [ DISPLAY ] button, 3 times.

The display condition is changed as shown below when the [ DISPLAY ] button is pressed.

Code display → Code + Picture display (1) → Code + Picture display (2) → ICS display → Code display .....

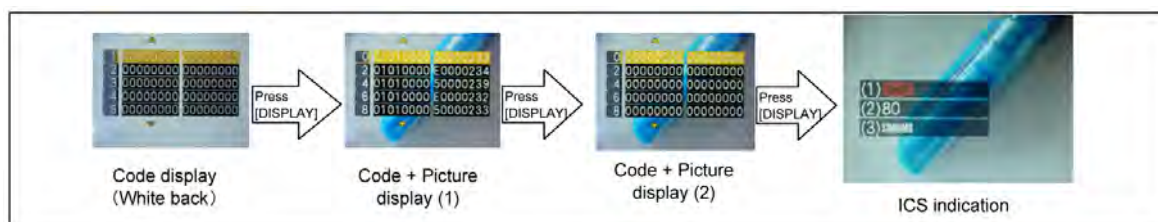

### 3. How to read

**(1). Jitter alert was displayed or not:**  
 This part shows that the "Jitter alert" mark was displayed or not when the picture has just before been taken.  
 + With "Jitter alert" mark : The "Jitter alert" mark was displayed.  
 + Without "Jitter alert" mark: The "Jitter alert" mark was not displayed.  
 [About "Jitter alert" mark]  
 Due to lacking the enough light amount etc, shooting condition prone to make a "hand jitter", the "Jitter alert" mark is displayed.  
 [Reference Guide]  
 (Applicable settings : Normal picture mode, ISO100, WIDE edge, Flash OFF)  
 + The "Jitter alert" mark is displayed when the shutter speed is 1/15th and below.

**(2). ISO Sensitivity Setting condition:**  
 This part shows that the "ISO Sensitivity" setting condition when the picture had been taken.  
 (Note: The [i ISO] is displayed when the "Intelligent ISO" was selected.)  
 For instance, when the recorded picture information shows [ISO100], it can be confirmed the ISO setting condition ; [AUTO], [INTELLIGENT ISO] or [ISO 100](Fixed: set by user).  
 [Point for Confirmation]  
 \*The symptom is "Picture with "hand jitter". Subject is not clearly stopped," in darker scene, does the picture was taken with lower ISO setting mode?  
 \*The symptom is "Noisy picture. Rough picture image" in brighter scene, does the picture was taken with higher ISO setting mode?

**(3). Color effect Setting condition:**  
 This part shows that the "Color effect" setting condition when the picture had been taken.

[ICS display (Sample)]



(1). Jitter alert mark : [Indicated]  
 (2). ISO sens. setting : [ISO]  
 (3). Color effect setting: Standard

Normal playback screen  
 (Recorded picture with information)



\*In playback mode, the picture information is displayed when pressing the [DISPLAY] button. (It can be confirmed at user as well.)  
 \*Use this indication together with ICS function

[Reference Guide : Settings "When taking picture"]

**<ISO SENSITIVITY>**  
 \*This allows the sensitivity to light (ISO sensitivity) to be set. Setting to a higher figure enables pictures to be taken even in dark places without the resulting pictures coming out dark.  
 \*The higher the value set for the ISO sensitivity, the more the jitter is reduced but the greater the amount of picture noise.  
 \*Depending on the brightness and how fast the subject is moving, jitter may not be avoided even if [iISO] is selected.  
 \*Movements may not be detected when a moving subject is small, when a moving subject is at the edge of the screen or when a subject has moved at the very moment when the shutter button was pressed fully.  
 \*The setting is fixed to [iISO] in the following cases.  
 -In [SPORTS], [BABY1]/[BABY2], [PET] and [FLASH BURST] in Scene Mode  
 \*Program Shift cannot be activated when the ISO sensitivity is set to [iISO].  
 \*You cannot select [iISO] in Shutter-Priority AE Mode and Manual Exposure Mode.  
 \*Fixed to [AUTO] except for [CUSTOM] in My Color Mode.  
 \*To avoid picture noise, we recommend reducing the ISO sensitivity, setting [NOISE REDUCTION] in [FILM MODE] towards [+] or setting the items except [NOISE REDUCTION] towards [-] to take pictures.

| ISO sensitivity                  | 80                          | 12800           |
|----------------------------------|-----------------------------|-----------------|
| Recording location (recommended) | When it is light (outdoors) | When it is dark |
| Shutter speed                    | Slow                        | Fast            |
| Noise                            | Less                        | Increased       |

| ISO sensitivity                         | Settings   |
|---|--|
| AUTO*                                   | The ISO sensitivity is automatically adjusted according to the brightness.   |
| [iISO]* (Intelligent)                   | The ISO sensitivity is adjusted according to the movement of the subject and the brightness.   |
| 80/100/200/400/800/1600/3200/6400/12800 | The ISO sensitivity is fixed to various settings. (When the [ISO INCREMENTS] in [REC] mode menu is set to [1/3 EV], items of ISO sensitivity that can be set will increase.) |





### 4. How to exit:

Simply, turn the power off. (Since ICS function is executed under the condition of temporary cancellation of "INITIAL SETTINGS", it wake up with normal condition when turn off the power.)

# 7 Service Fixture & Tools

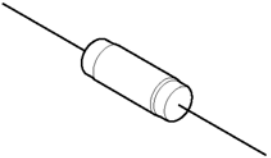
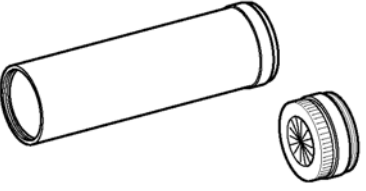
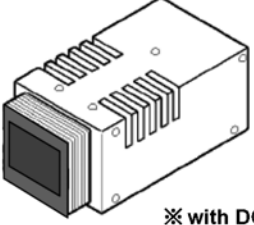
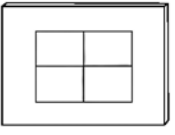
## 7.1. Service Fixture and Tools

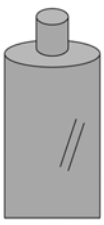
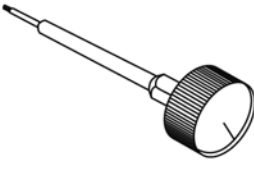
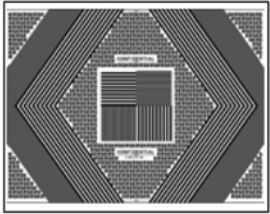
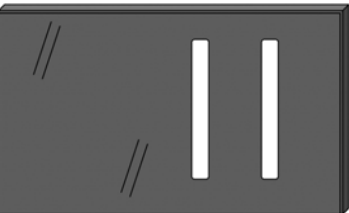
The following Service Fixture and tools are used for checking and servicing this unit.

|  |   |  |
|--|---|--|
| <p>Resistor for Discharging<br/>ERG5SJ102</p>  | <p>Infinity Lens (with Focus Chart)<br/>RFKZ0422</p>  | <p>LIGHT BOX<br/>RFKZ0523</p>  |
|  <p>An equivalent type of Resistor may be used.</p> |                                        |  <p>※ with DC Cable<br/>* VFK1164TDVLB can be used.</p> |
| <p>TR Chart<br/>RFKZ0443</p>   | <p>Lens Cleaning Kit (BK)<br/>VFK1900BK</p>   | <p>Grease (for lens)<br/>RFKZ0472</p>  |
|   |  <p>* Only supplied as 10 set/box.</p> |   |
| <p>Screw locking glue<br/>RFKZ0573</p>   | <p>Driver (for optical axis adjustment)<br/>RFKZ0569</p>  | <p>Optical axis adjustment chart<br/>RFKZ0570</p>  |
|   |                                      |   |
| <p>Camera stand<br/>RFKZ0333J</p>  | <p>Torque Driver<br/>RFKZ0542</p>   |  |
|   |                                      |  |

## 7.2. When Replacing the Main P.C.B.

After replacing the MAIN P.C.B., be sure to achieve adjustment.

The service software is available at "TSN Website". To download, click on "Support Information from NWBG/VDBG-AVC".

## 7.3. Service Position

This Service Position is used for checking and replacing parts. Use the following Extension cables for servicing.

Table S1 Extension Cable List

| No. | Parts No. | Connection                                 | Form         |
|-----|-----------|--|--------------|
| 1   | RFKZ0416  | FP9001 (MAIN) - CCD UNIT                   | 41PIN 0.3FFC |
| 2   | VFK1364   | FP9002 (MAIN) - FLASH FPC - FP8001 (FLASH) | 14PIN 0.5FFC |
| 3   | RFKZ0477  | FP9003 (MAIN) - LCD UNIT                   | 45PIN 0.3FFC |
| 4   | RFKZ0477  | FP9005 (MAIN) - LENS UNIT                  | 45PIN 0.3FFC |
| 5   | VFK1441   | FP9006 (MAIN) - AF/MF-ASPECT FPC           | 8PIN 0.5FFC  |
| 6   | VFK1974   | FP9010 (MAIN) - LCD UNIT                   | 4PIN 0.5FFC  |
| 7   | RFKZ0379  | PP9001 (MAIN) - PS9901 (TOP)               | 40PIN B to B |

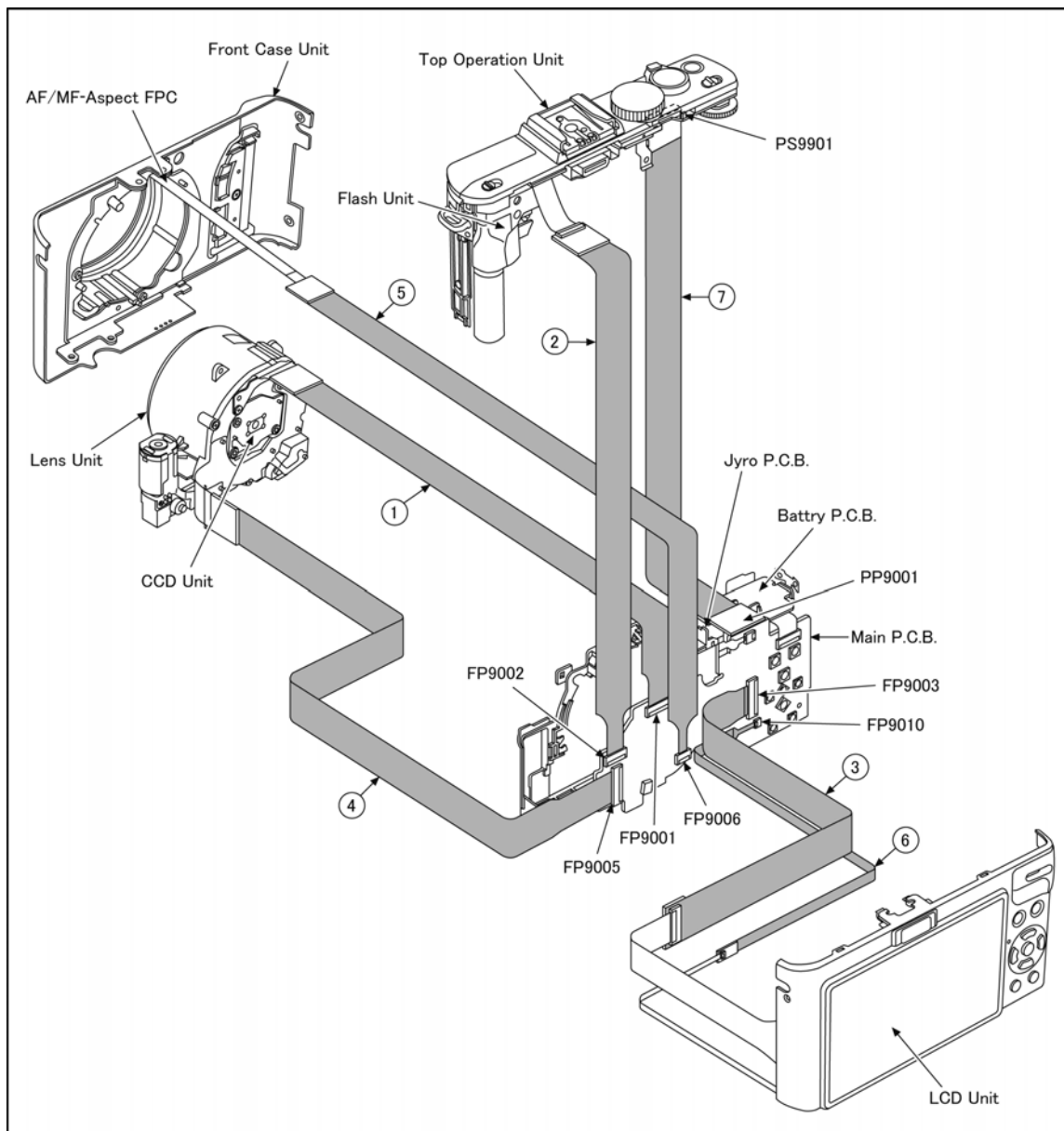

### CAUTION-1. (When servicing FLASH P.C.B.)

1. Be sure to discharge the E.capacitor on FLASH P.C.B..  
Refer to "HOW TO DISCHARGE THE E.CAPACITOR ON FLASH P.C.B.".  
The E.capacitor voltage is not lowered soon even if the AC Cord is unplugged or the battery is removed.
2. Be careful of the high voltage circuit on FLASH P.C.B..
3. DO NOT allow other parts to touch the high voltage circuit on FLASH P.C.B..

# 8 Disassembly and Assembly Instructions

## 8.1. Disassembly Flow Chart

This is a disassembling chart.

When assembling, perform this chart conversely.

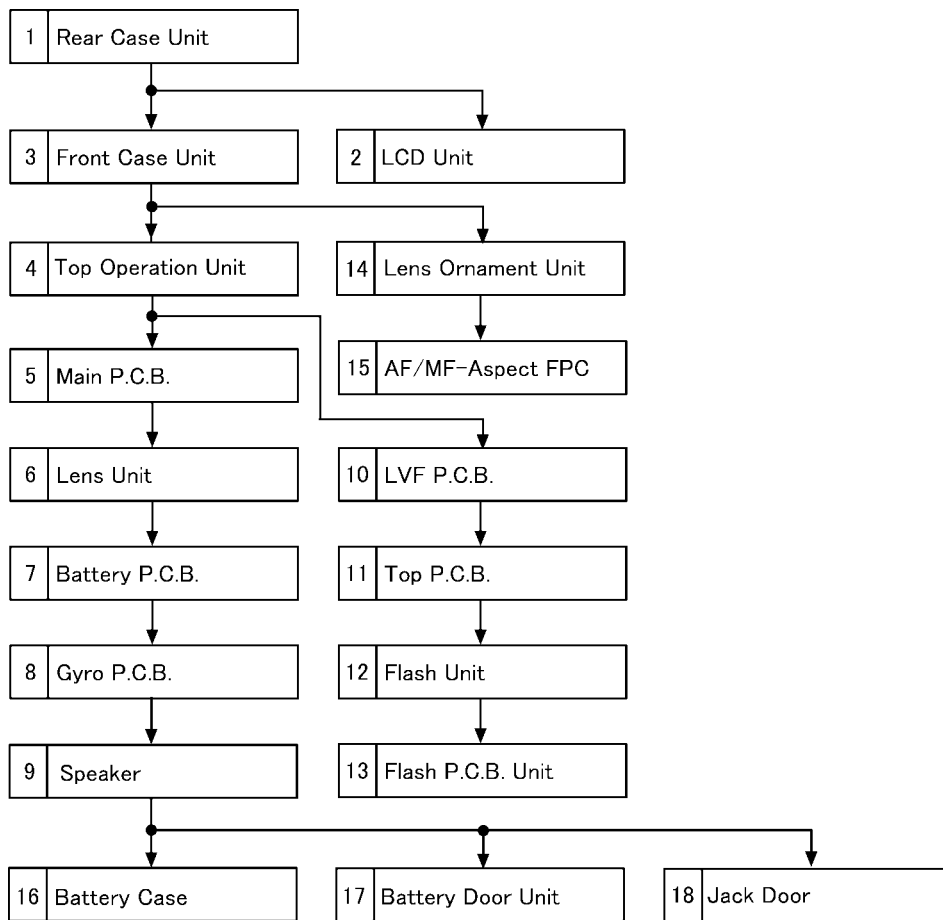

## 8.2. P.C.B. Location

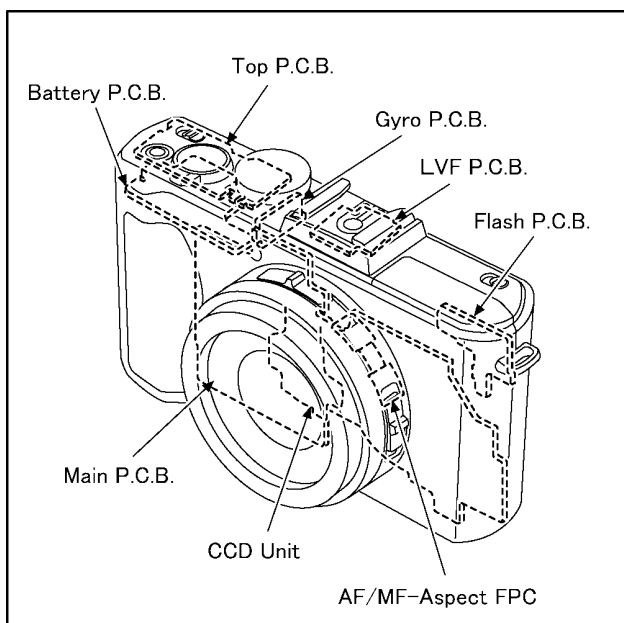

### 8.3. Disassembly Procedure

| No. | Item               | Fig        | Removal                 |
|-----|--------------------|------------|-------------------------|
| 1   | Rear Case Unit     | (Fig. D1)  | Card                    |
|     |                    |            | Battery                 |
|     |                    |            | 3 Screws (A)            |
|     |                    |            | 1 Screw (B)             |
|     |                    |            |                         |
|     |                    | (Fig. D2)  | Shoe Spring             |
|     |                    |            | 2 Screws (C)            |
|     |                    |            | FP9003(Flex)            |
|     |                    |            | FP9010(Flex)            |
|     |                    |            | Rear Case Unit          |
| 2   | LCD Unit           | (Fig. D3)  | 2 Locking tabs          |
|     |                    |            | 2 Hanging parts         |
|     |                    |            | LVF Jack Holder         |
|     |                    |            | Capton Tape             |
|     |                    |            | 1 Locking tab           |
|     |                    |            | 2 Hanging parts         |
|     |                    |            | LCD Holder              |
|     |                    |            | LCD Unit                |
|     |                    |            |                         |
|     |                    |            |                         |
| 3   | Front Case Unit    | (Fig. D4)  | FP9006(Flex)            |
|     |                    |            | 3 Screws (D)            |
|     |                    |            | 4 Screws (E)            |
|     |                    |            | 1 Screw (F)             |
|     |                    |            | 2 Screws (G)            |
|     |                    |            | Front Case Unit         |
|     |                    |            |                         |
| 4   | Top Operation Unit | (Fig. D5)  | 1 Screw (H)             |
|     |                    |            | FP9002(Flex)            |
|     |                    |            | 3 Locking tabs          |
|     |                    |            | Top Operation Unit      |
|     |                    |            |                         |
| 5   | Main P.C.B.        | (Fig. D6)  | Tape                    |
|     |                    |            | FP9001(Flex)            |
|     |                    |            | FP9005(Flex)            |
|     |                    |            | FP9007(Flex)            |
|     |                    |            | FP9008(Flex)            |
|     |                    |            | FP9009(Connector)       |
|     |                    |            | 1 Screw (I)             |
|     |                    |            | 2 Locking tabs          |
|     |                    |            | Main P.C.B.             |
|     |                    |            |                         |
| 6   | Lens Unit          | (Fig. D7)  | 3 Locking tabs          |
|     |                    |            | Tripod                  |
|     |                    |            | Lens Unit               |
| 7   | Battery P.C.B.     | (Fig. D8)  | 1 Screw (J)             |
|     |                    |            | 1 Hanging part          |
|     |                    |            | Battery P.C.B.          |
| 8   | Gyro P.C.B.        | (Fig. D9)  | 2 Hanging parts         |
|     |                    |            | Gyro P.C.B.             |
| 9   | Speaker            | (Fig. D10) | Speaker Tape            |
|     |                    |            | Speaker                 |
| 10  | LVF P.C.B.         | (Fig. D11) | 2 Screws (K)            |
|     |                    |            | FP9971(Flex)            |
|     |                    |            | 1 Screw (L)             |
|     |                    |            | Shield Plate            |
|     |                    |            | LVF P.C.B.              |
| 11  | Top P.C.B.         | (Fig. D12) | AF Panel Light          |
|     |                    |            | 2 Screws (M)            |
|     |                    |            | FP9951(Flex)            |
|     |                    |            | 2 Locking tabs          |
|     |                    |            | Top P.C.B.              |
|     |                    | (Fig. D13) | NOTE: (When Installing) |
|     |                    |            |                         |
| 12  | Flash Unit         | (Fig. D14) | 5 Locking tabs          |
|     |                    |            | 3 ribs                  |
|     |                    |            | Flash Unit              |

| No. | Item               | Fig        | Removal             |
|-----|--------------------|------------|---------------------|
| 13  | Flash P.C.B. Unit  | (Fig. D15) | P8001(Connector)    |
|     |                    |            | P8002(Connector)    |
|     |                    |            | Strap Holder(R)     |
|     |                    |            | 2 Locking tabs      |
|     |                    |            | 1 Rib               |
|     |                    |            | FLK Unit            |
|     |                    |            | FL Tape(A)          |
|     |                    |            | Flash P.C.B. Unit   |
| 14  | Lens Ornament Unit | (Fig. D16) | 3 Screws (N)        |
|     |                    |            | Front Plate         |
|     |                    |            | Lens Ornament Unit  |
| 15  | AF/MF-Aspect FPC   | (Fig. D17) | 2 Screws (O)        |
|     |                    |            | AS Click Spring     |
|     |                    |            | FC Click Spring     |
|     |                    |            | Focus Sheet         |
|     |                    |            | Focus Knob          |
|     |                    |            | Aspect Sheet        |
|     |                    |            | AS Knob             |
|     |                    | (Fig. D18) | Lens Ring Front     |
|     |                    |            | 1 Screw (P)         |
|     |                    |            | Lens Ornament       |
|     |                    |            | 3 Screws (Q)        |
|     |                    |            | AF/MF-Aspect FPC    |
|     |                    |            |                     |
| 16  | Battery Case       | (Fig. D19) | 3 Locking tabs      |
|     |                    |            | Battery Out Spring  |
|     |                    |            | Battery Case        |
| 17  | Battery Door Unit  | (Fig. D20) | Battery Door Shaft  |
|     |                    |            | Battery Door Spring |
|     |                    |            | Battery Door Unit   |
| 18  | Jack Door          | (Fig. D21) | Jack Door Shaft     |
|     |                    |            | Jack Door           |



### 8.3.1. Removal of the Rear Case Unit

**NOTE:**

When servicing and reassembling, remove the card and battery from the unit.

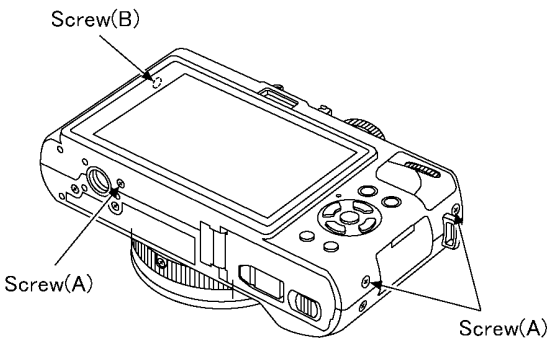
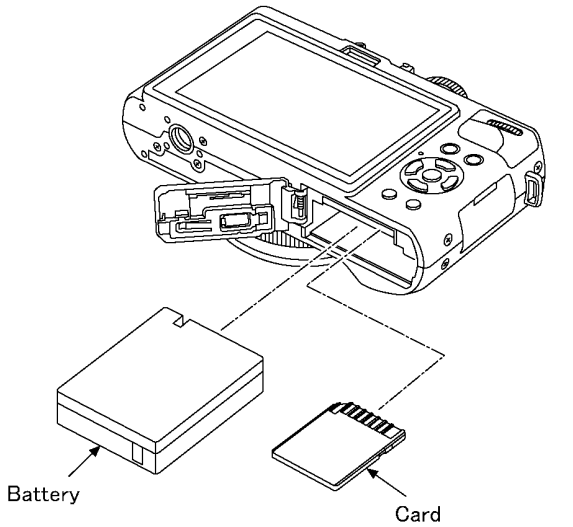
- Card
- Battery
- Screw(A) × 3
- Screw(B) × 1



| Screw(A)  | Screw(B)  |
|---|---|
|  3.3mm |  2.5mm |
| Ⓚ: BLACK  | Ⓚ: BLACK  |
| Ⓜ: SILVER   | Ⓜ: SILVER   |

(Fig. D1)

- Shoe Spring
- Screw(C) × 2
- FP9003(Flex)
- FP9010(Flex)

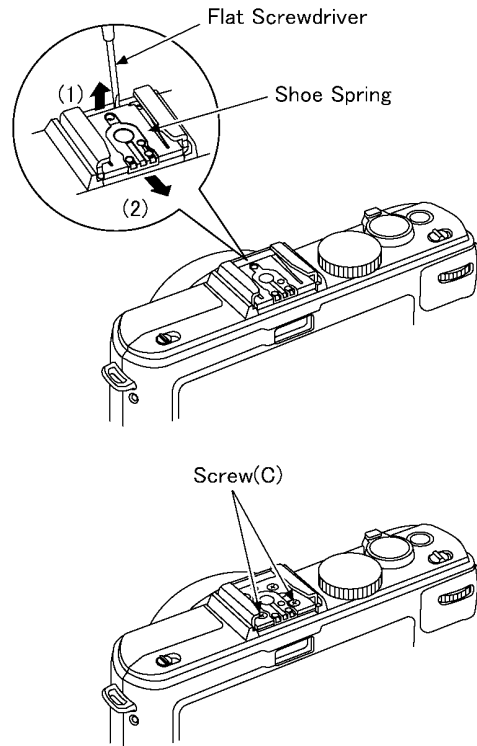

**NOTE: (When Replacing)**

- When remove the flex, pull up the locking tab in the direction of arrow (1), and then remove the flex in the direction of arrow (2).

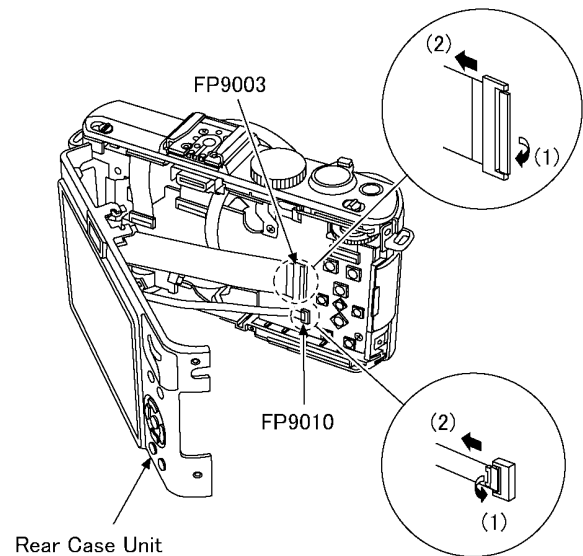

| Screw(C)  |
|---|
|  5.5mm |
| SILVER  |

(Fig. D2)

### 8.3.2. Removal of the LCD Unit

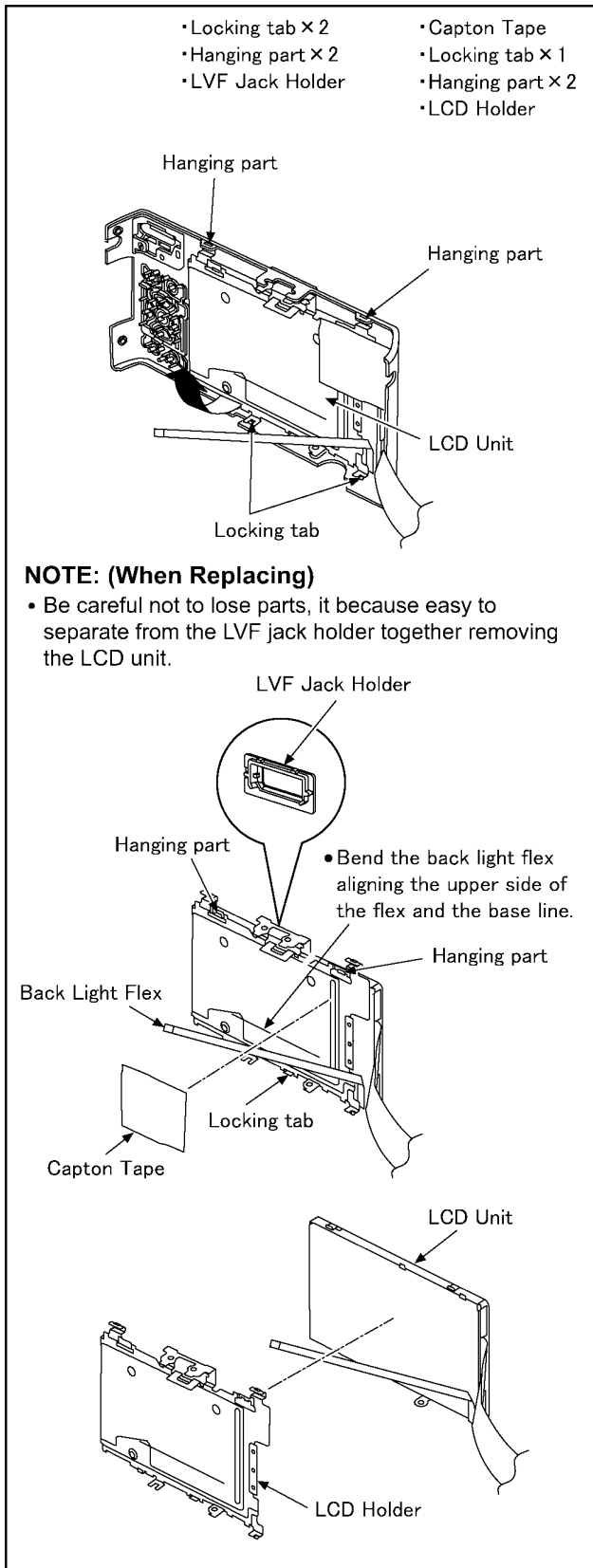

(Fig. D3)

### 8.3.3. Removal of the Front Case Unit

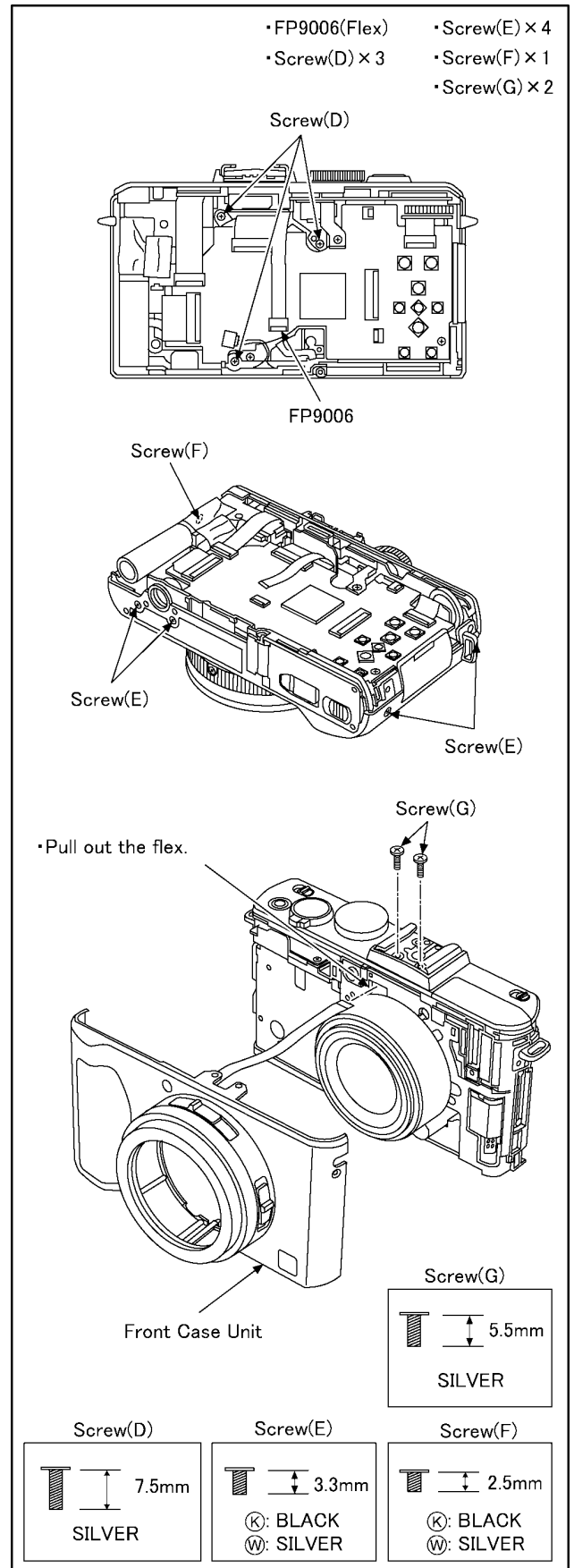

(Fig. D4)

### 8.3.4. Removal of the Top Operation Unit

**IMPORTANT NOTICE:**

Take care not apply any bending load to the charging capacitor. It brings about the possibility of P.C.B. and/or component damage on the Flash P.C.B. Unit.

- Screw(H) × 1
- Locking tab × 3
- FP9002(Flex)

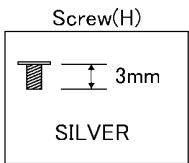
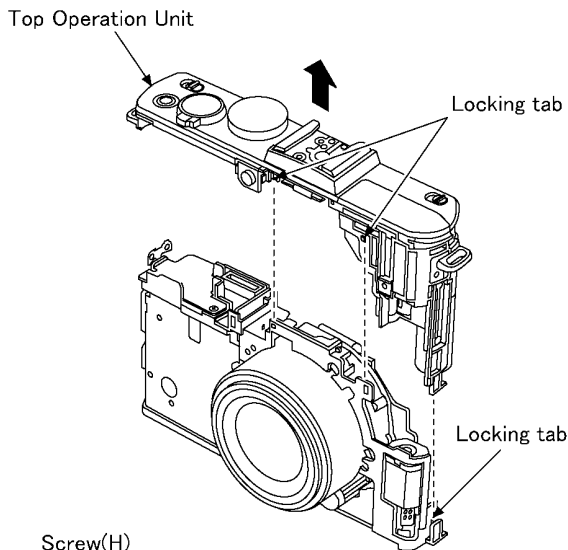
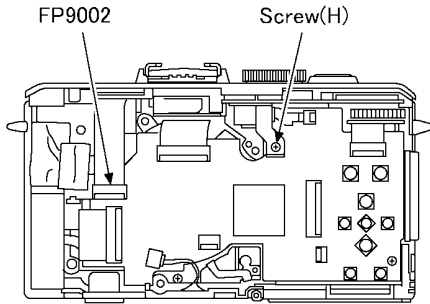

(Fig. D5)

### 8.3.5. Removal of the Main P.C.B.

- Tape
- FP9001(Flex)
- FP9005(Flex)
- FP9007(Flex)
- FP9008(Flex)
- FP9009(Connector)
- Screw(I) × 1
- Locking tab × 2

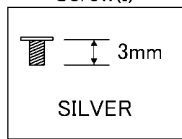
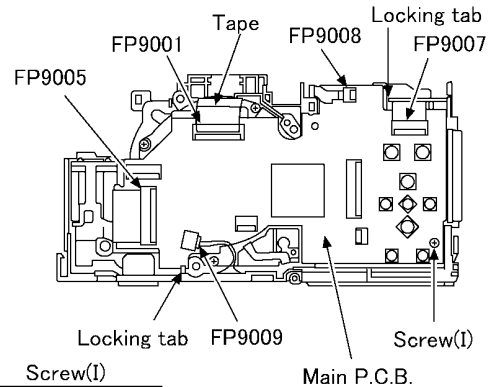

(Fig. D6)

### 8.3.6. Removal of the Lens Unit

- Locking tab × 3
- Tripod

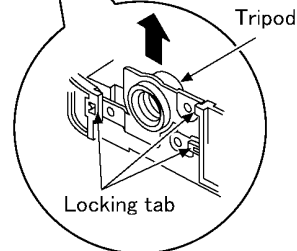
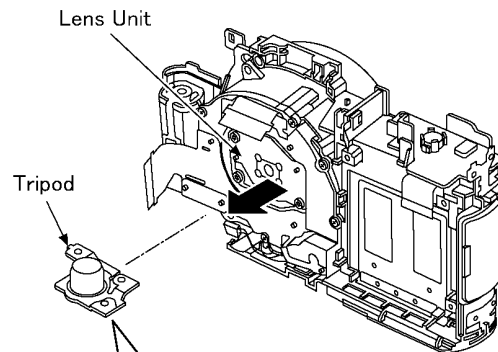

(Fig. D7)

### 8.3.7. Removal of the Battery P.C.B.

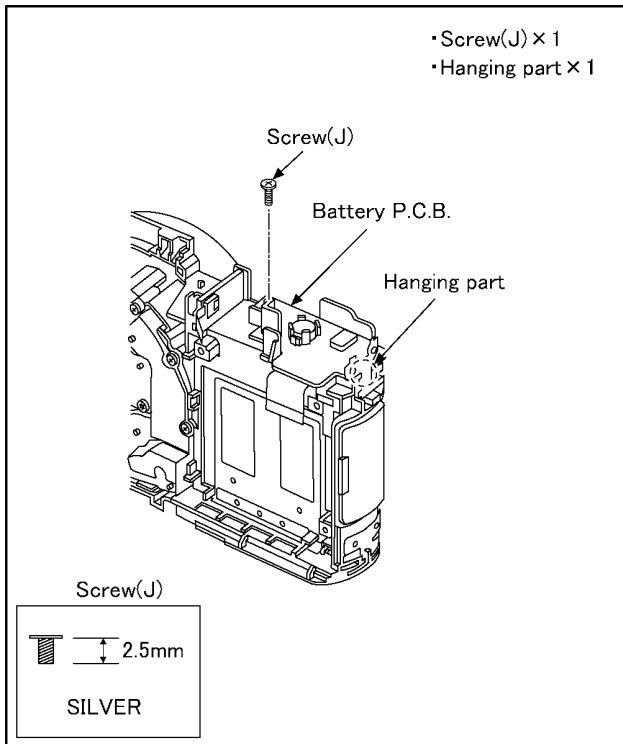

(Fig. D8)

### 8.3.8. Removal of the Gyro P.C.B.

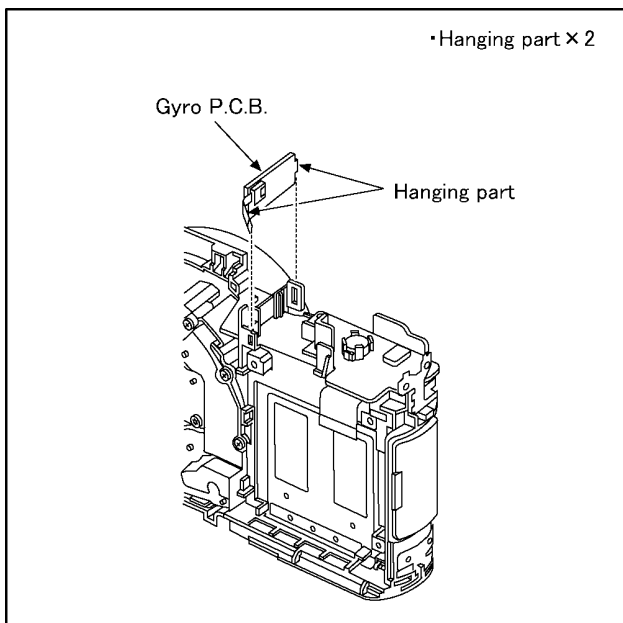

(Fig. D9)

### 8.3.9. Removal of the Speaker

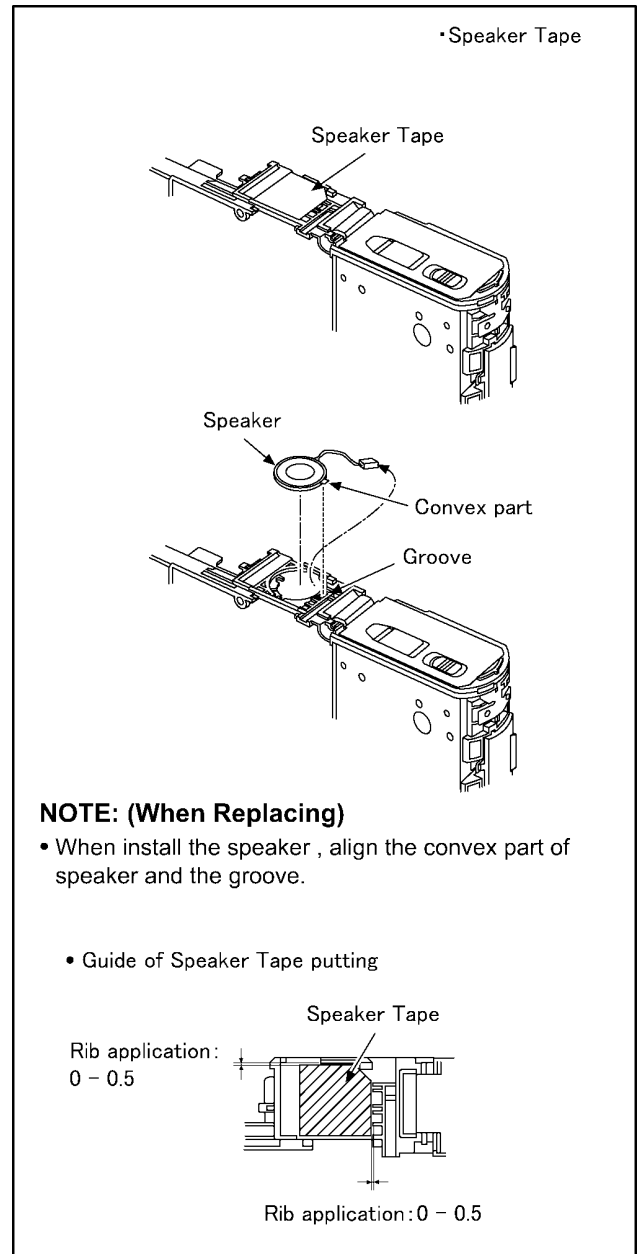

(Fig. D10)

### 8.3.10. Removal of the LVF P.C.B.

**IMPORTANT NOTICE:**

Take care not apply any bending load to the charging capacitor. It brings about the possibility of P.C.B. and/or component damage on the Flash P.C.B. Unit.

- Screw(K) × 2
- Screw(L) × 1
- FP9971(Flex)
- Shield Plate

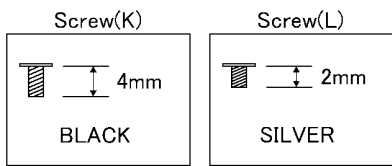
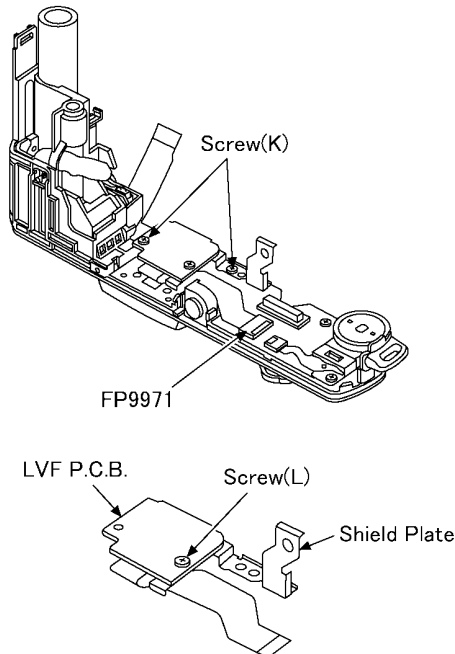

(Fig. D11)

### 8.3.11. Removal of the Top P.C.B.

**IMPORTANT NOTICE:**

Take care not apply any bending load to the charging capacitor. It brings about the possibility of P.C.B. and/or component damage on the Flash P.C.B. Unit.

- AF Panel Light
- Screw(M) × 2
- FP9951(Flex)
- Locking tab × 2

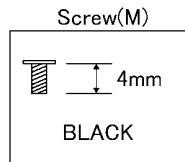
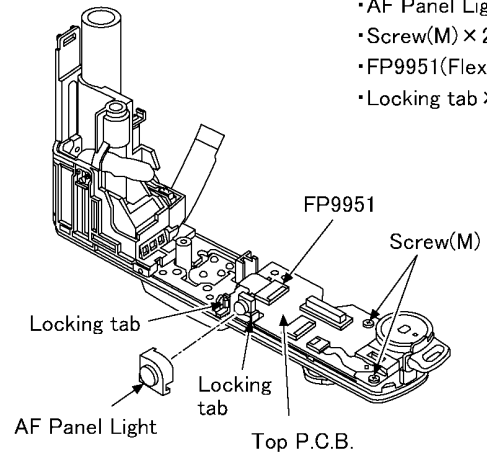

(Fig. D12)

**IMPORTANT NOTICE:**

Take care not apply any bending load to the charging capacitor. It brings about the possibility of P.C.B. and/or component damage on the Flash P.C.B. Unit.

**NOTE: (When Installing)**

- Align the convex of power switch and the groove of power knob.
- Align the D cut of mode switch and the D cut of coupling plate, and then install the coupling plate to the top p.c.b..
- Align the convex of coupling plate and the concave part of mode knob.

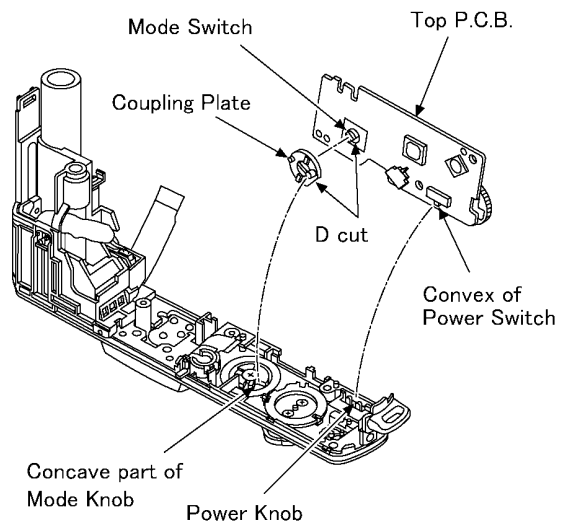

(Fig. D13)

### 8.3.12. Removal of the Flash Unit

**IMPORTANT NOTICE:**

Take care not apply any bending load to the charging capacitor. It brings about the possibility of P.C.B. and/or component damage on the Flash P.C.B. Unit.

- Locking tab × 5
- Rib × 3

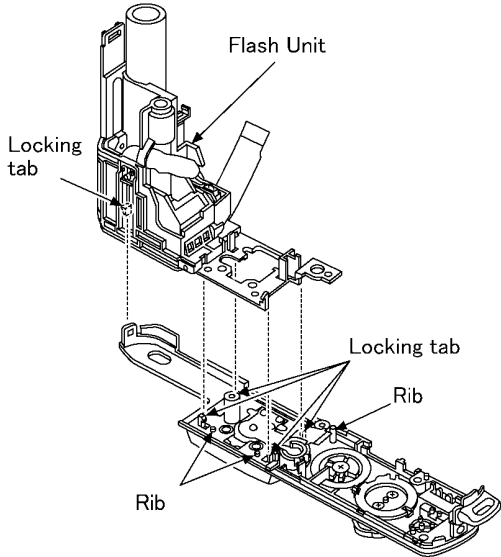

(Fig. D14)

### 8.3.13. Removal of the Flash P.C.B. Unit

**IMPORTANT NOTICE:**

Take care not apply any bending load to the charging capacitor. It brings about the possibility of P.C.B. and/or component damage on the Flash P.C.B. Unit.

- P8001(Connector)
- P8002(Connector)
- Strap Holder(R)
- Locking tab × 2
- Rib × 1
- FLK Unit
- FL Tape(A)

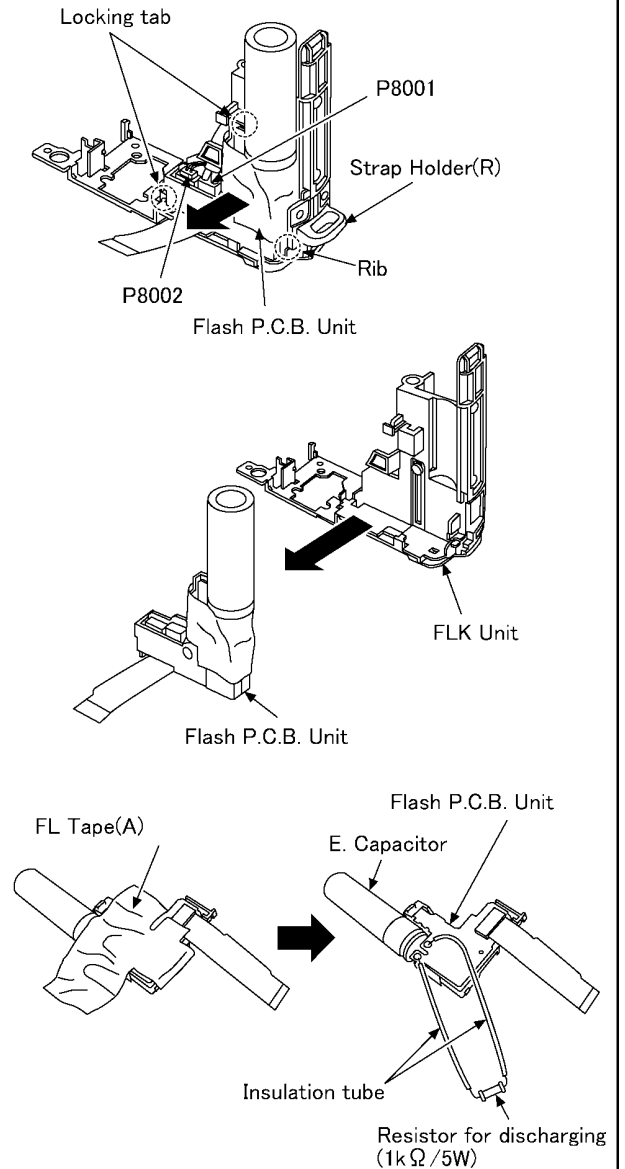

**CAUTION**

Be sure to discharge the capacitor on Flash P.C.B. unit before disassembling.

1. Remove the Flash P.C.B. unit.
2. Remove the fl tape(A) carefully.
3. Put the insulation tube on the lead part of resistor (ERG5SJ102: 1kΩ/5W).
4. Put the resistor between both terminals of capacitor unit for approx. 5 seconds.

(Fig. D15)

### 8.3.14. Removal of the Lens Ornament Unit

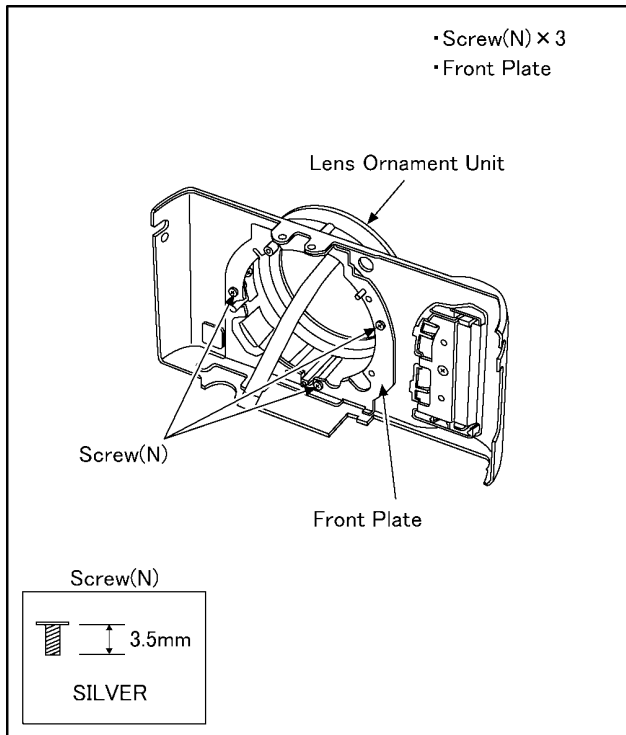

(Fig. D16)

### 8.3.15. Removal of the AF/MF-Aspect FPC

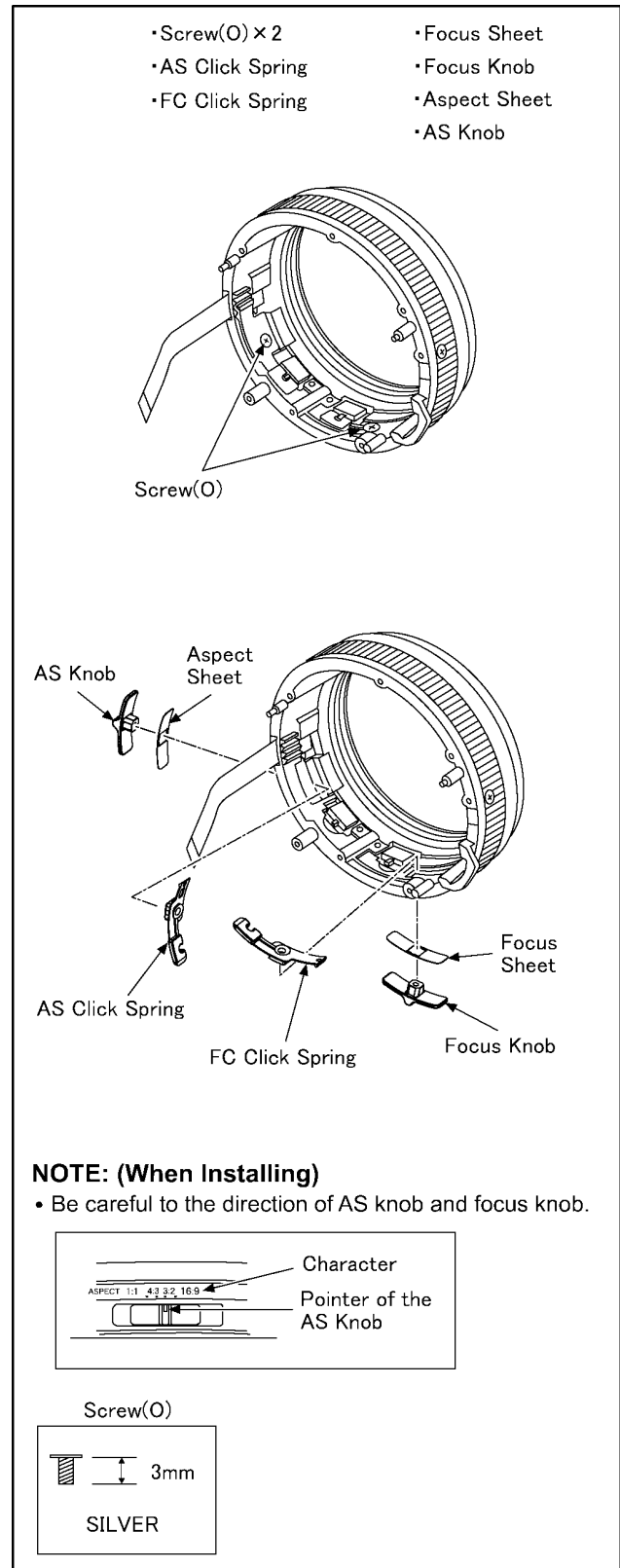

(Fig. D17)

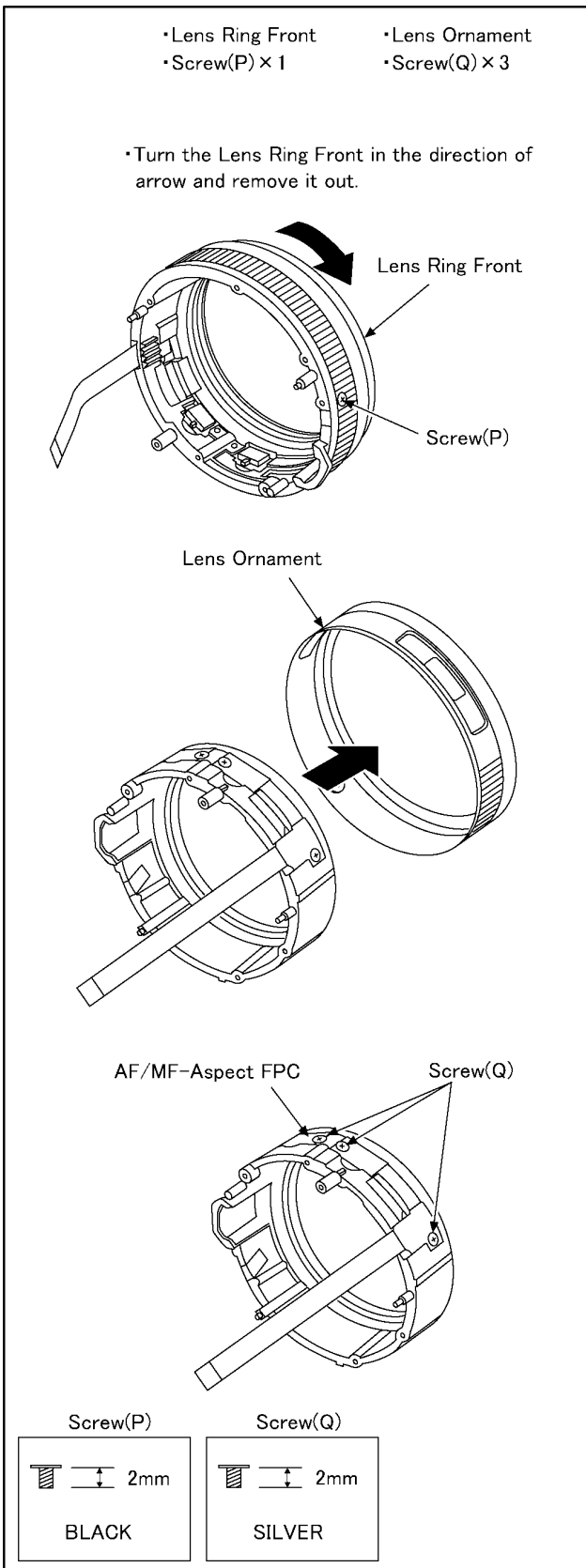

(Fig. D18)

### 8.3.16. Removal of the Battery Case

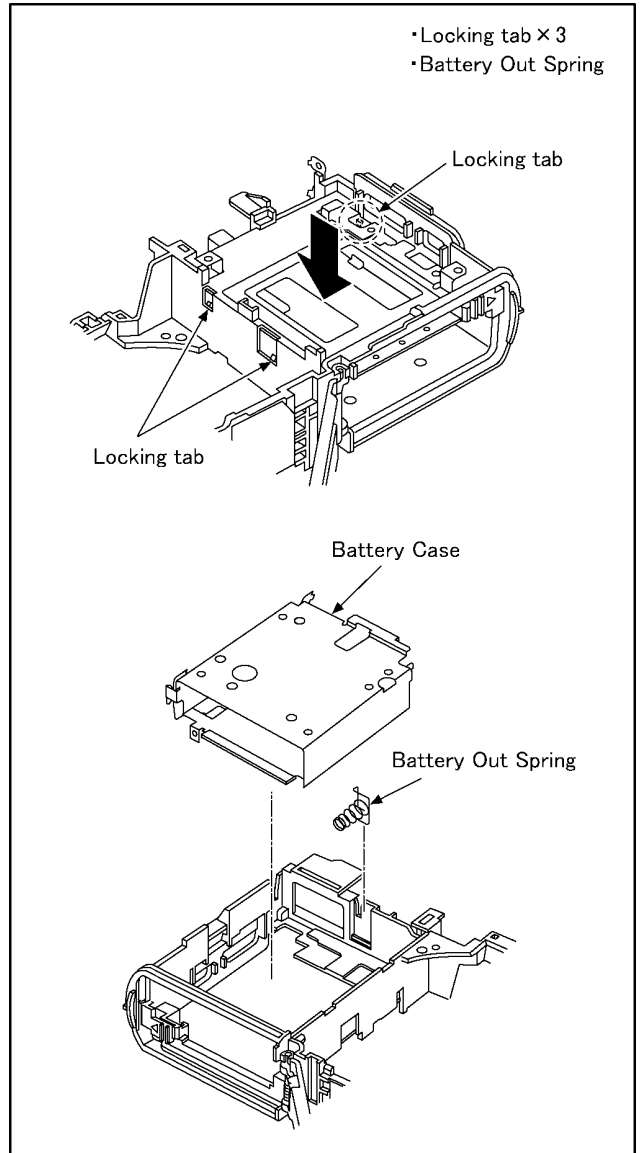

(Fig. D19)

### 8.3.17. Removal of the Battery Door Unit

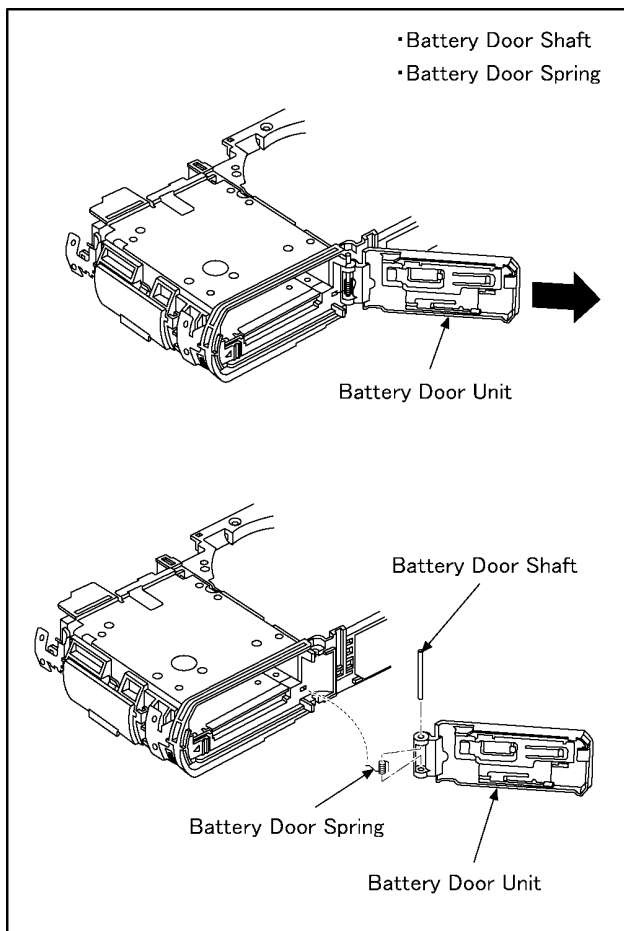

(Fig. D20)

### 8.3.18. Removal of the Jack Door

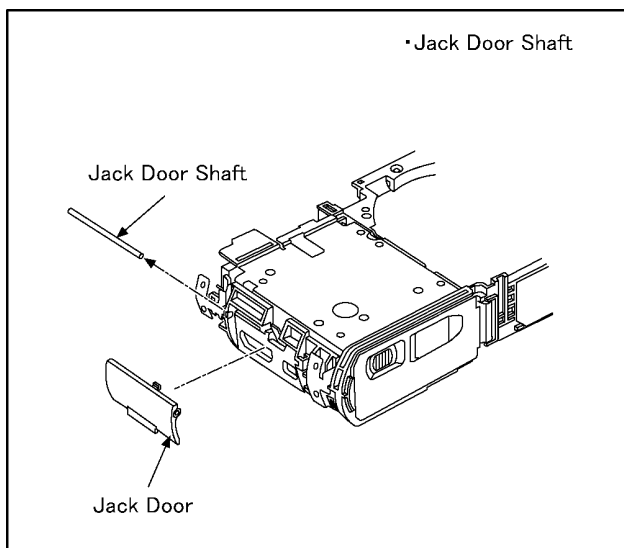

(Fig. D21)

#### **NOTE: (When Installing)**

Make sure to confirm the following points when installing:

- The Screw is tightened enough.
- Installing conditions are fine. (No distortion, no abnormal-space.)
- No dust and/or dirt on Lens surfaces.
- LCD image is fine. (No dust and dirt on it, and no gradient images.)

## 8.4. Lens Disassembly Procedure

### Precaution:

1. Do not remove the CCD unit when disassembling or re-assembling the lens in order to maintain it clean.  
The screw fitting the CCD unit to the master flange unit is fixed by the screw locking glue with the adjustment of the installation angle of the CCD unit against the lens (optical tilt adjustment) finished.  
When remove it, refer to item "8.6."
2. Keep dust or dirt away from the lens.  
To remove dirt or dust from the lens, blow with dry air.
3. Do not touch the lens surface.
4. Use lens cleaning KIT (VFK1900BK).
5. Apply grease (RFKZ0472) as shown on "THE APPLICATION OF GREASE METHOD" in the figure.

### 8.4.1. Removal of the Zoom Motor and Lens FPC P.C.B. Unit

1. Remove the 8 solders (A).
2. Unscrew the 2 screws (A).
3. Remove the 2 locks.
4. Remove the zoom motor to the direction of arrow (1).
5. Unscrew the 1 screw (B).
6. Remove the photo sensor.
7. Remove the 18 solders (B).
8. Remove the 4 solders (C).
9. Remove the 7 locks.
10. Remove the lens FPC P.C.B. unit.

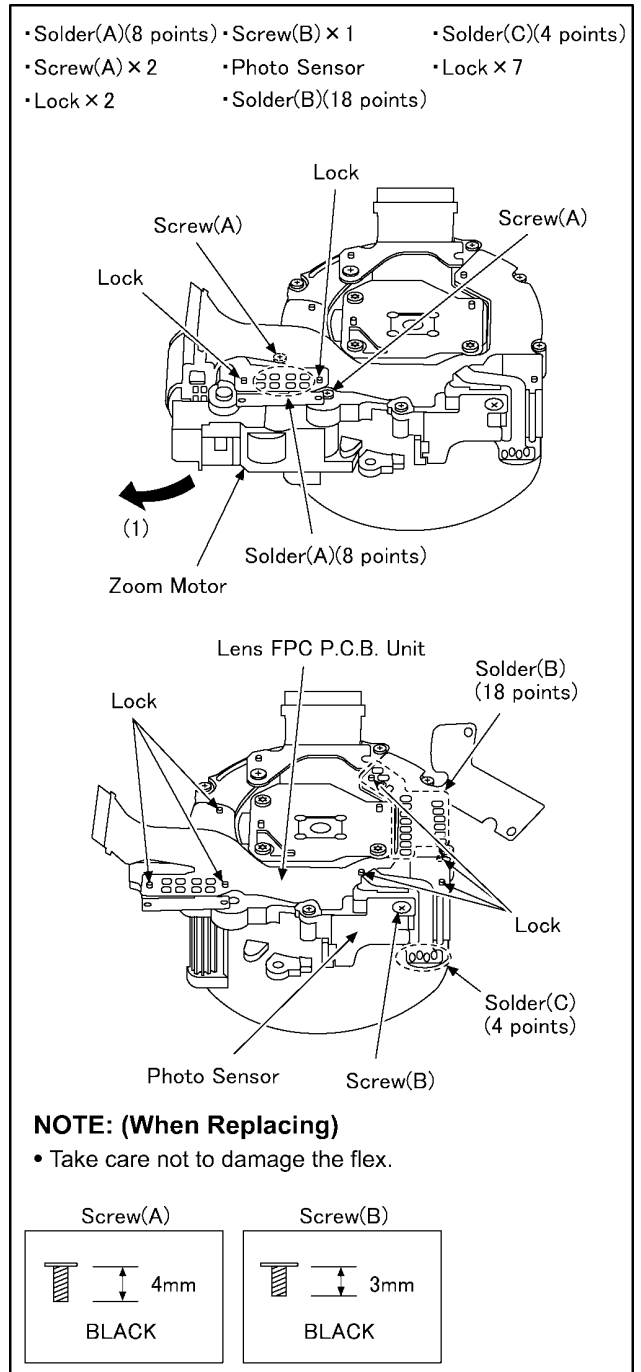

### 8.4.2. Removal of the Master Flange Unit

1. Unscrew the 3 screws (C).
2. Detach the flex from 1 convex of master flange unit.
3. Remove the master flange unit.

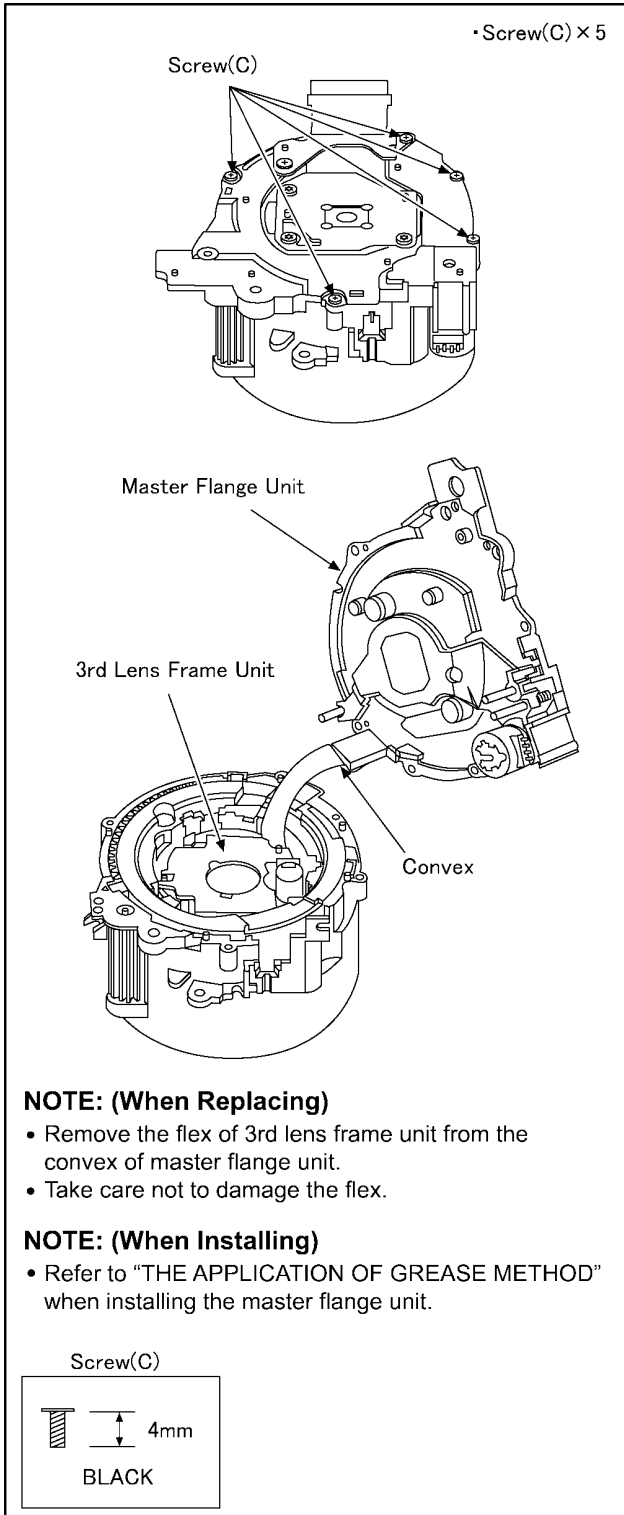

### 8.4.3. Removal of the 1st Lens Frame Unit/Both Sides Cam Frame/2nd 3rd Direct Frame/2nd Lens Frame Unit/3rd Lens Frame Unit

1. Push the 1st lens frame unit from the lens front side in the direction of arrow, and then remove the unit of 1st lens frame unit/both sides cam frame/2nd 3rd direct frame/2nd lens frame unit/3rd lens frame unit from the fix frame unit/1st drive frame unit.

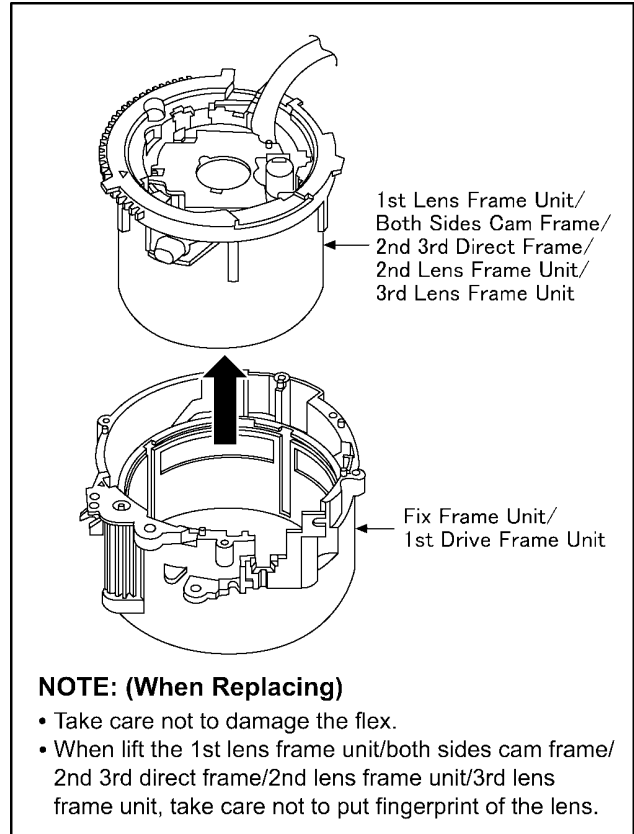

#### 8.4.4. Removal of the Both Sides Cam Frame/2nd 3rd Direct Frame/2nd Lens Frame Unit/3rd Lens Frame Unit

1. Turn the both sides cam frame/2nd 3rd direct frame/2nd lens frame unit/3rd lens frame unit, and then remove the both sides cam frame/2nd 3rd direct frame/2nd lens frame unit/3rd lens frame unit from the 1st lens frame unit.

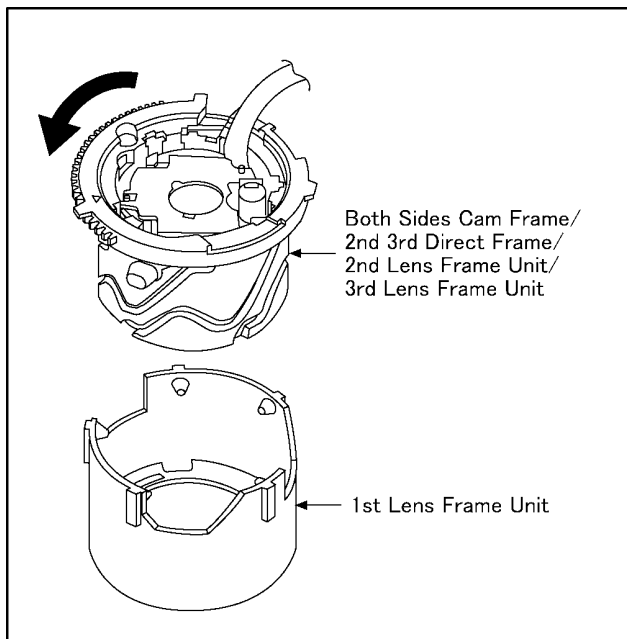

#### 8.4.5. Removal of the 2nd 3rd Direct Frame/2nd Lens Frame Unit/3rd Lens Frame Unit

1. Remove the unit of 2nd 3rd direct frame/2nd lens frame unit/3rd lens frame unit from the both sides cam frame.

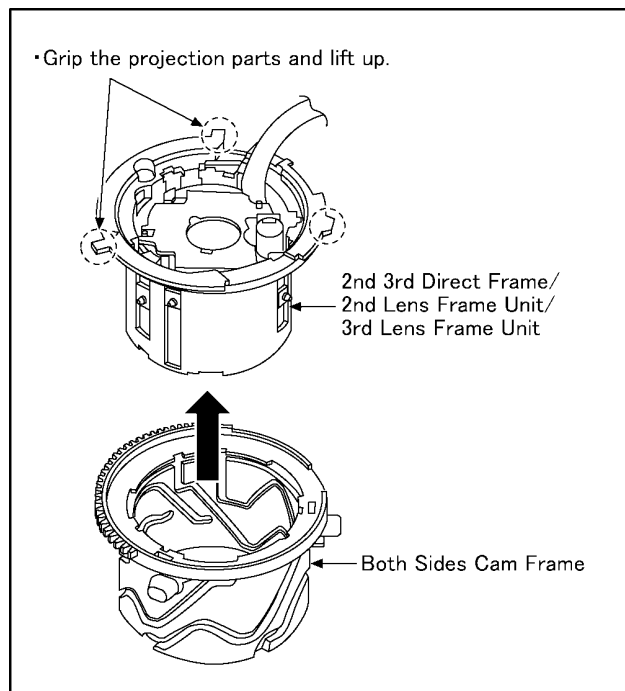

### 8.4.6. Removal of the 2nd Lens Frame Unit and 3rd Lens Frame Unit

1. Push the 2nd lens frame unit from the lens front side in the direction of arrow, and then remove the 3rd lens frame unit and 2nd lens frame unit from the 2nd 3rd direct frame.

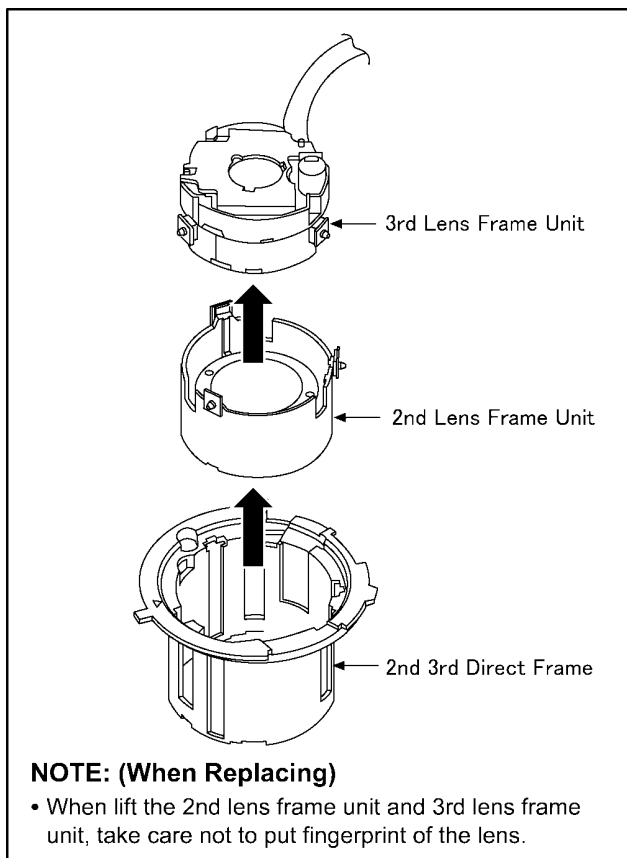

### 8.5. Assembly Procedure for the Lens

#### 8.5.1. Phase alignment of the 1st Lens Frame Unit and Both Sides Cam Frame

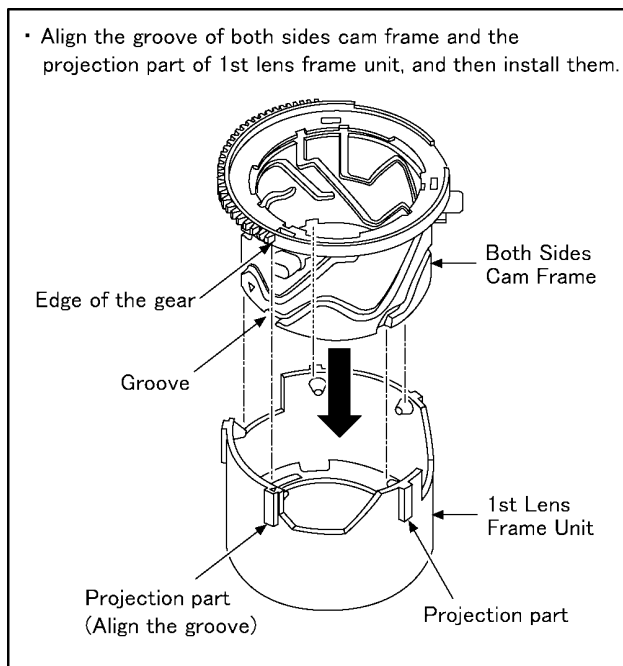

### 8.4.7. Removal of the 1st Drive Frame Unit

1. Remove the 1st lens frame unit from the fix frame unit.

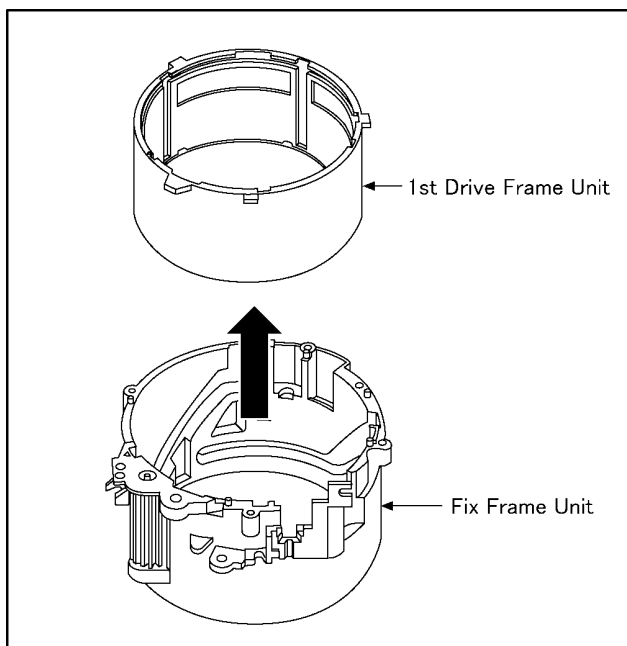

### 8.5.2. Phase alignment of the 1st Lens Frame Unit/Both Sides Cam Frame and 2nd 3rd Direct Frame

- Align the  $\Delta$  mark of 1st lens frame unit/both sides cam frame and the  $\Delta$  mark of 2nd 3rd direct frame, and then install them.
- Align the phase of the groove of 2nd 3rd direct frame and the groove of 1st lens frame unit/both sides cam frame (6 points).

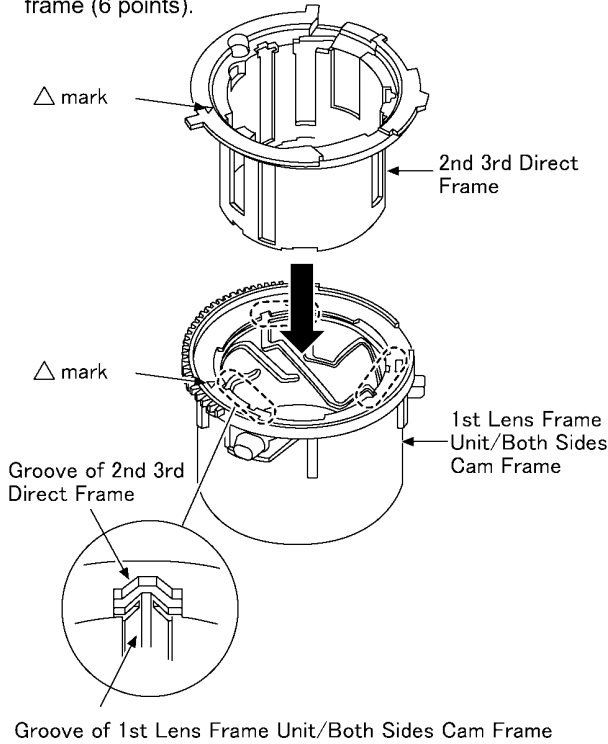

### 8.5.3. Phase alignment of the 1st Lens Frame Unit/Both Sides Cam Frame/ 2nd 3rd Direct Frame and 1st Drive Frame Unit

- Align the  $\Delta$  mark of 1st lens frame unit/both sides cam frame/2nd 3rd direct frame and the  $\Delta$  mark of 1st drive frame unit, and then install them.

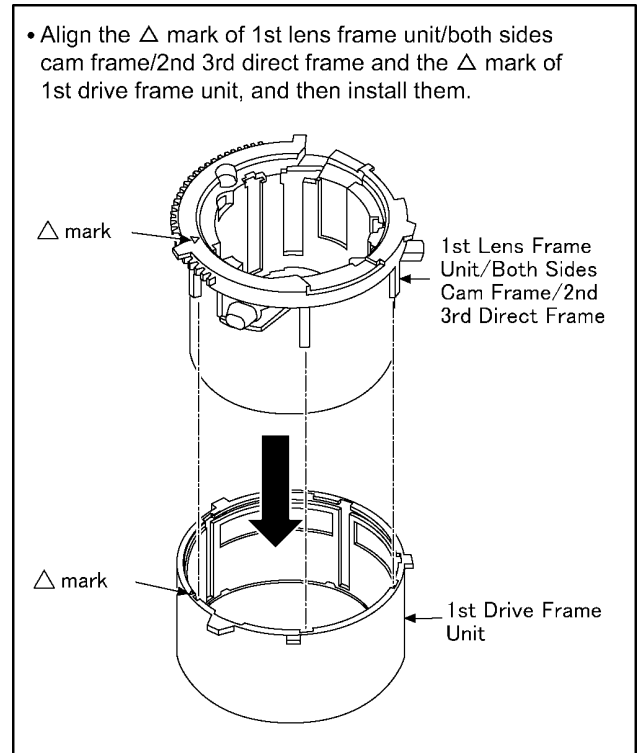

### 8.5.4. Phase alignment of the 1st Lens Frame Unit/Both Sides Cam Frame/ 2nd 3rd Direct Frame/1st Drive Frame Unit and 2nd Lens Frame Unit

- Align the  $\Delta$  mark of 1st lens frame unit/both sides cam frame/2nd 3rd direct frame/1st drive frame unit, and the  $\Delta$  mark of 2nd lens frame unit, and then install them.

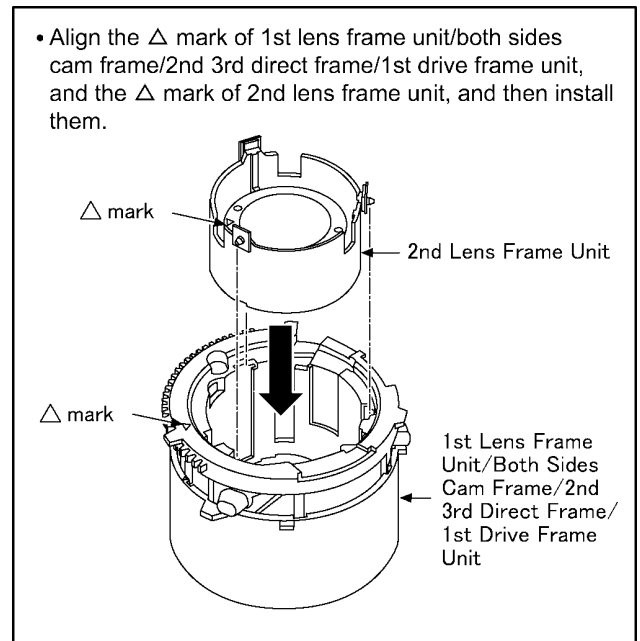

**8.5.5. Phase alignment of the 1st Lens Frame Unit/Both Sides Cam Frame/2nd 3rd Direct Frame/1st Drive Frame Unit/2nd Lens Frame Unit and 3rd Lens Frame Unit**

- Align the  $\Delta$  mark of 1st lens frame unit/both sides cam frame/2nd 3rd direct frame/1st drive frame unit/ 2nd lens frame unit, and the  $\Delta$  mark of 3rd lens frame unit, and then install them.

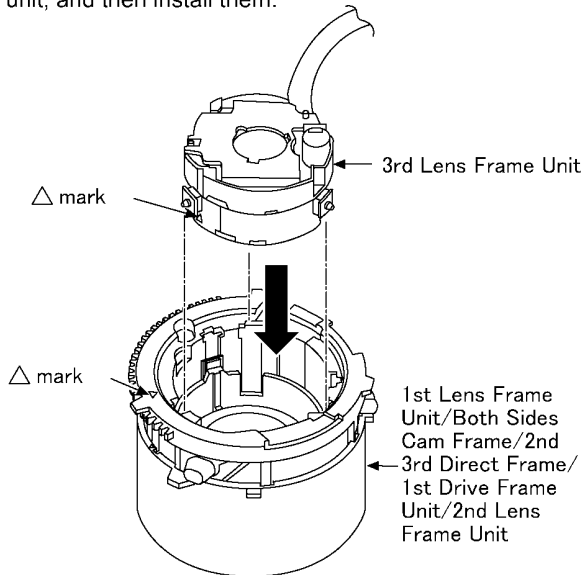

**8.5.6. Phase alignment of the 1st Lens Frame Unit/Both Sides Cam Frame/2nd 3rd Direct Frame/1st Drive Frame Unit/2nd Lens Frame Unit/3rd Lens Frame Unit and Fix Frame Unit**

- Align the  $\Delta$  mark of 1st lens frame unit/both sides cam frame/2nd 3rd direct frame/1st drive frame unit/ 2nd lens frame unit/3rd lens frame unit, and the  $\Delta$  mark of fix frame unit, and then install them.

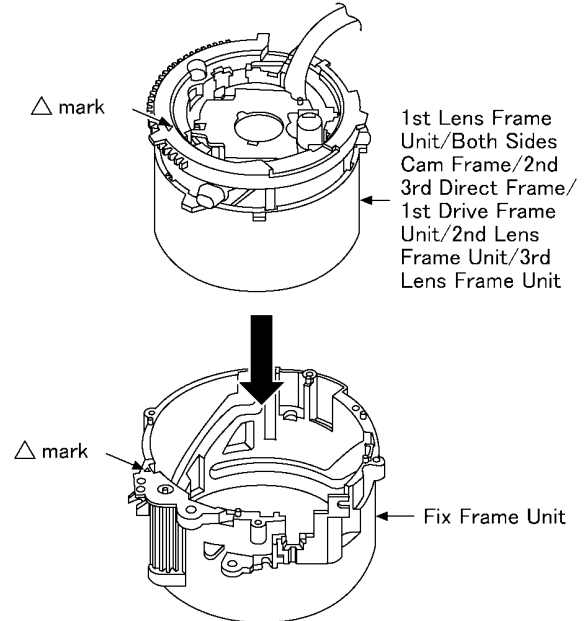

### 8.5.7. Install of the Master Flange Unit

• Screw(C) × 5

• Insert the convex to positioning hole of flex and install to flex insert part.

Flex  
Flex Insert part  
Master Flange Unit

**NOTE: (When Replacing)**

- Take care not to damage the flex.
- Refer to "THE APPLICATION OF GREASE METHOD" when installing the master flange unit.

Screw(C)  
Master Flange Unit

Screw(C)

4mm  
BLACK

### 8.5.8. Install of the Zoom Motor and Lens FPC P.C.B. Unit

- Lock × 7
- Solder(B)(18 points)
- Solder(C)(4 points)
- Photo Sensor
- Lock × 2
- Screw(A) × 2
- Solder(A)(8 points)

Lens FPC P.C.B. Unit  
Lock  
Solder(B) (18 points)  
Lock  
Solder(C) (4 points)  
Photo Sensor  
Screw(B)

• When installing screw (B), Shift the photo sensor in the direction of the arrow, then tighten it.

Lock  
Screw(A)  
Lock  
Screw(A)  
Solder(A)(8 points)  
Zoom Motor

**NOTE: (When Replacing)**

- Take care not to damage the flex.

| Screw(B)         | Screw(A)         |
|------------------|------------------|
| <br>3mm<br>BLACK | <br>4mm<br>BLACK |

## 8.6. Removal of the CCD Unit

When remove the CCD unit once (the screw(E) is loosened even a little), the optical tilt adjustment is required.

When loosen the screw(E), necessary the optical tilt adjustment at the end of assembling. (Refer to item "9.3.2.")

To prevent the CCD unit from catching the dust and dirt, do not remove the CCD unit except for replacing.

### ■ CAUTION

- The screw(E) is fixed by the screw locking glue with the optical tilt adjustment finished. When remove the CCD unit, wipe the screw locking glue away carefully.
- Don't reuse the screw(E) that the screw locking glue adheres to keep dust or dirt away from the CCD unit. (When installing, take new screw(E).)

- Screw(D) × 1
- Screw(E) × 3
- CCD FPC Plate
- CCD Spring

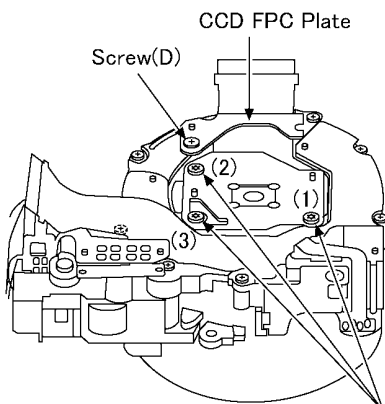

Screw(E)

- Screws(1)(2) are for adjustment, screw(3) is for fix.

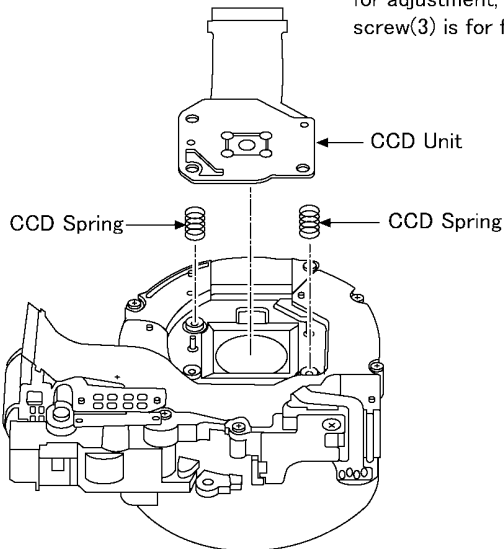

Screw(D)

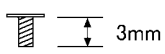

BLACK

Screw(E)

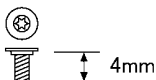

SILVER  
Special Screw  
(T4 Torx type)

### NOTE: (When Installing)

- Take new screw.  
(Don't reuse the screw that the screw locking glue adheres.)
- Tighten the 3 special screws according to the following.
  - Set the bit of adjustment driver(RFKZ0569) to the torque driver(RFKZ0542).
- [Screw order]: (3)→(1)→(2).
- [Screw torque]:  $10 \pm 1 \text{ N} \cdot \text{cm}$ .
- Be sure to execute the optical tilt adjustment with the screw (1) and (2).
- After the adjustment is finished, apply the screw locking glue as shown in the figure below.
- Apply the screw locking glue thinly on the head of screw to the sheet metal with a toothpick.
- Don't apply the screw locking glue where it is applied before disassembling.

(Example)

This is the case where the screw locking glue is applied to inside of the slash area.

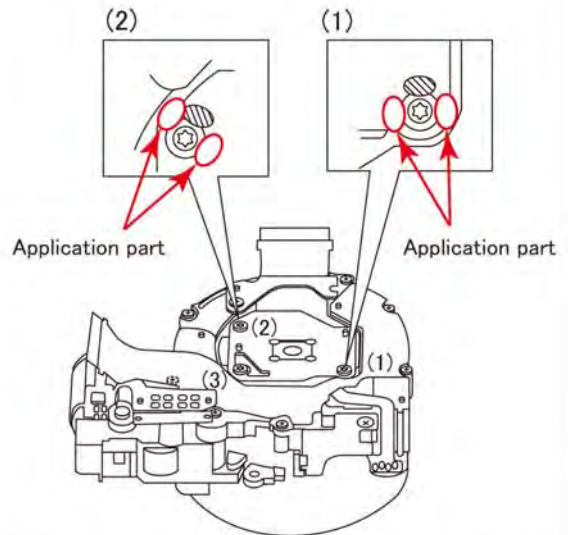

## 8.7. Removal of the Focus Motor

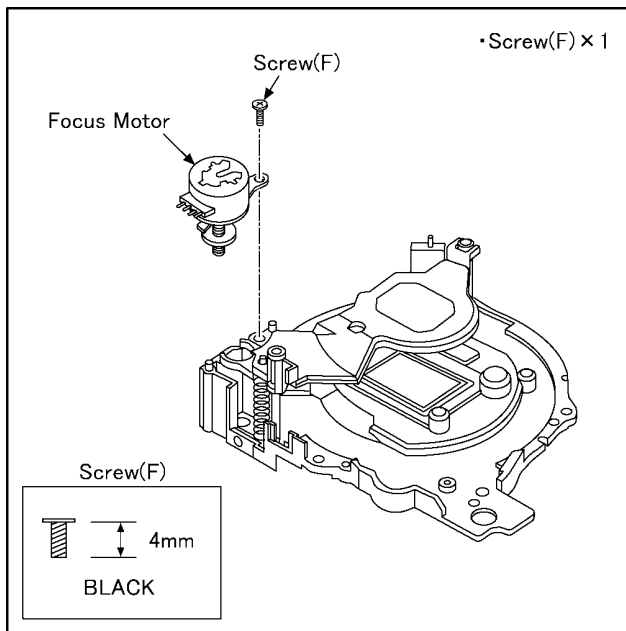

## 8.8. The Application of Grease Method

The grease application parts of lens unit are as follows.  
Apply grease additionally in the specified position if necessary.  
When the grease is applied, use a toothpick and apply thinly.

- Focus motor (lead screw)/Fasten groove of nut/Guide pole
  - Grease: RFKZ0472
  - Amount of application: 2 - 4 mg
- Resin pin
  - Grease: RFKZ0472
  - Amount of application: 1 - 2 mg

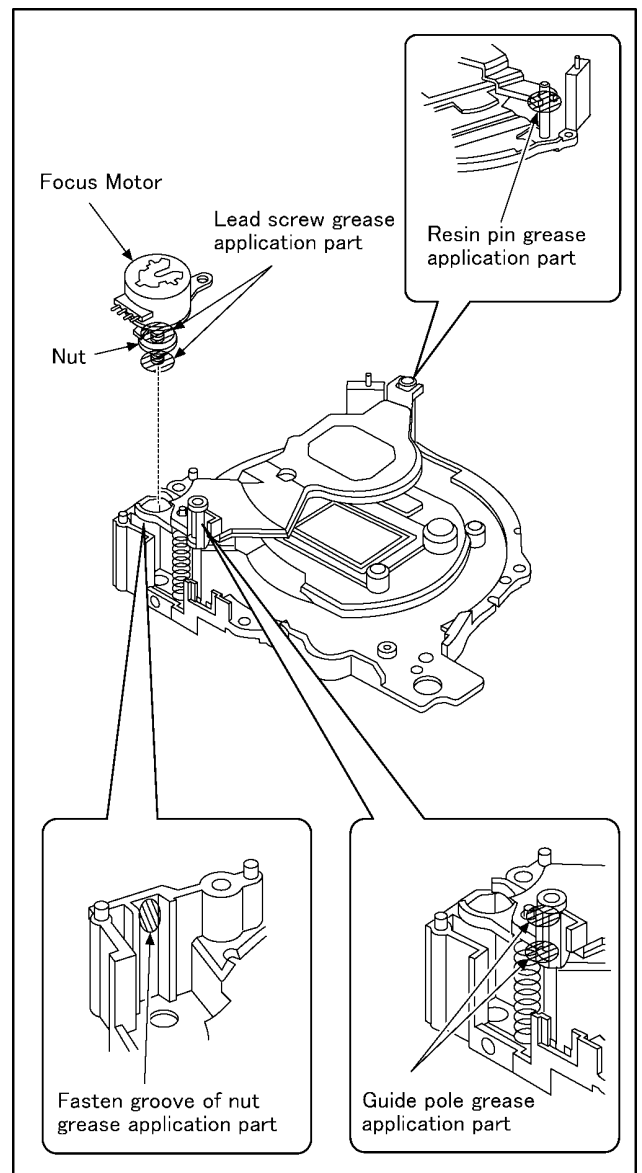

# 9 Measurements and Adjustments

## 9.1. Introduction

When servicing this unit, make sure to perform the adjustments necessary based on the part(s) replaced. Before disassembling the unit, it is recommended to back up the camera data stored in flash-rom as a data file.

### **IMPORTANT NOTICE (After replacing the MAIN P.C.B.)**

After replacing the MAIN P.C.B., it is necessary to use the "DIAS" software to allow the release of adjustment flag(s).

The Adjustment software "DIAS" is available at "TSN Website". To download, click on "Support Information from NWBG/VDBG-AVC".

\*DIAS (DSC Integrated Assist Software)

### **NOTE: (When replacing the Lens unit, Master flange unit and CCD unit)**

- When the CCD unit is unavoidably removed for Lens unit, Master flange unit and CCD unit replaced, an optical adjustment is necessary after parts are exchanged.
- The adjustment software (DSC\_Tilt) is necessary to execute an optical adjustment.
- Please inquire the adjustment software of the service base or the CS promotion center.

## 9.2. Before Disassembling the unit

### 9.2.1. Initial Setting Release

The cameras specification are initially set in accordance with model suffix (such as EB, EG, GK, GC, and so on.).

Unless the initial setting is not released, an automatic alignment software in the camera is not able to be executed when the alignment is carried out.

#### **Note:**

The initial setting should be again done after completing the alignment. Otherwise, the camera may not work properly.

Therefore as a warning, the camera display a warning symbol "!" on the LCD monitor every time the camera is turned off.

Refer to the procedure described in "3.6.2 INITIAL SETTINGS" for details.

#### **[ How to Release the camera initial setting ]**

##### **Preparation:**

1. Attach the Battery or AC Adaptor with a DC coupler to the unit.  
(Since this unit has built-in memory, it can be performed without inserting SD memory card.)

##### **Step 1. Temporary cancellation of "INITIAL SETTINGS":**

Set the mode dial to "[ P ] (Program AE mode)".

While keep pressing "[ UP ] of Cursor button" and [ MOTION PICTURE ] button simultaneously, turn the Power on.

##### **Step 2. Cancellation of "INITIAL SETTINGS":**

Press the [ PLAYBACK ] button, then playback the picture.

Press "[ UP ] of Cursor button" and [ MOTION PICTURE ] button simultaneously. (The camera will beep after this.)

Turn the Power off. (The warning symbol "!" is displayed on the LCD monitor.)

## 9.2.2. Flash-Rom Data Backup

When trouble occurs, it is recommended to backup the Flash-rom data before disassembling the unit.

There are two kinds of Flash-rom data backup methods:

### [ ROM\_BACKUP (Method of Non-PC backup) ]

1. Insert the SD-card into the camera.
2. Set the camera to "Temporary cancellation of the initial settings".
3. Select the "SETUP" menu.  
From the "SETUP" menu, select "ROM BACKUP".

#### NOTE:

This item is not listed on the customer's "SETUP" menu.

4. When this "ROM\_BACKUP" item is selected, the following submenus are displayed.



Fig.2-1



Fig.2-2

| Item                   | Function  | Details   |
|------------------------|---|---|
| DSC → SD               | Save all the DSC's Flash-rom data to SD-CARD  | *DSC's Flash-rom data is saved to the SD-CARD as a data file by the same format as the TATSUJIN software for the previous models. (DATA BACKUP)<br>-File location: ROOT DIRECTORY in SD-CARD.<br>-File Name:<br>1) User Setup Information data: <Model Number>U.txt [Example: DMC-FX66 : "FX66U.txt"]<br>2) Optical Adjustment data: <Model Number>F.txt [Example: DMC-FX66 : "FX66F.txt"]<br>*If the concerned file already exists, "OVERWRITE?" message is displayed. |
| SDALL → DSC (ID CHECK) | Write the all data to DSC's Flash-rom from SD-CARD  | *The backup data being stored in the SD card is transferred to DSC unit.<br>*ID CHECK: When the model ID is different, data is not transferred.   |
| SDALL → DSC (FORCE)    | Write the all data to DSC's Flash-rom from SD-CARD  | *FORCE: Even if the model ID is different, data is transferred.<br>※If the main PCB is replaced, select "SDALL → DSC (FORCE)".  |
| SDUSER → DSC (FORCE)   | Only "User setup information" is written from the saved file in the SD-CARD to DSC's Flash-rom. | *Only the user's "setup" setting condition is transferred to DSC unit.<br>*FORCE: Even if the model ID is different, the data is transferred.   |
| ! → LUMIX              | Shipping set without initializing "User setup information"                                      | *Initial setting is executed without initializing the user's set up setting condition.<br>※ The initial setting must be performed while the Self-timer LED is blinking.<br>※ The picture data stored in the built-in memory of the DSC is not erased, with this operation.  |

### [ DSC Integrated Assist Software (Method of Using PC) ]

Same as TATSUJIN software for previous models.

## 9.2.3. Light Box

If using VFK1164TDVLB Light Box, remove the lens connection ring by loosening three hexagon screws.

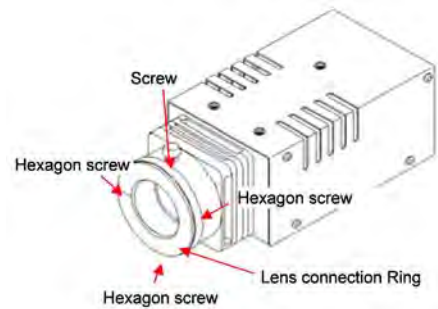

## 9.3. Details of Electrical Adjustment

### 9.3.1. How to execute the Electrical Adjustment

It is not necessary to connect the camera to a PC to perform adjustments.

“Flag reset operation” and “Initial setting operation” are required when carrying out the alignment, follow the procedure below.

#### 9.3.1.1. Startup Electrical Adjustment mode

1. Release the initial settings.
2. Insert a recordable SD card.  
(Without a SD card, the automatic adjustment can not executed.)
3. Procedure to set the camera into adjustment mode:
  - a. Set the mode dial to “[ P ] (Program AE mode)”.
  - b. Turn the Power off.
  - c. Turn the Power on pressing [ MENU/SET ] and [ MOTION PICTURE ] simultaneously.  
LCD monitor displays “SERVICE MODE”.(Refer to Fig. 3-1)



Fig.3-1

#### 9.3.1.2. Status Adjustment Flag Setting

Reset (Not yet adjusted) the status flag condition.

1. After pressing the [ DISPLAY ] button, the LCD monitor displays the Flag status screen (Refer to Fig.3-2)
2. Select item by pressing the Cursor buttons. (Gray cursor is moved accordingly.)
3. Press the [ Delete ] button.

**NOTE:**

The selected item's flag has been changed from “F (green)” to “0 (yellow)”.

\*Flag conditions:

F (green)

means that the alignment has been completed and the status flag condition is set. In this case, the flag condition should be reset, if you try to carry out the automatic alignment.

0 (yellow)

means that the alignment has been not “completed” and the status flag condition is “reset”. In this case, automatic alignment is available.



Fig.3-2

- In case of setting the status flag into set condition again without completion of the alignment, the status flag should be SET by using PC, or UNDO by using ROM BACKUP function.

### 9.3.1.3. Execute Adjustment (In case of “OIS Adjustment”)

1. Perform step “9.3.1.1.” to “9.3.1.2.”, to reset the OIS flag status “F” (Set) to “0” (Reset)
2. Press [ DISPLAY ] button after Flag reset.  
OIS Adjustment screen is displayed on the LCD panel.  
(Refer to Fig.3-3)
3. Press the [ Shutter ] button. The adjustment will start automatically.



Fig.3-3

4. When the adjustment is completed successfully, adjustment report menu appears with Green OK on the LCD monitor. (Refer to Fig.3-4)



Fig.3-4

### 9.3.1.4. Attention point during Adjustment

1. Step “9.3.1.3.” procedure shows OIS adjustment as an example. To perform the adjustment, refer to the “9.3.2. Adjustment Specifications” table which shows key point for each adjustment.
2. Do not move the light box, the camera or the chart while adjusting. If one of these is moved accidentally, start the adjustment again.
3. Do not press any buttons/keys until the default menu (Fig.3-5) is displayed on the LCD monitor. Otherwise, adjustment data may not be stored properly.
4. If the adjustment is interrupted accidentally, the alignment data may not be properly saved in the Flash-rom.



Fig.3-5

### 9.3.1.5. Finalizing the Adjustment

1. Several adjustment flags can be reset (“F” into “0”) at the same time. In this case, when the adjustment has been completed, the screen will change showing the adjustment for the next item until all reset items are completed.  
Also, when the shutter button is pressed, the screen jump to the next adjustment item.
2. To cancel the adjustment mode while in the process of performing the adjustment, follow this procedures.
  - (1) Press [ Delete ] button.
  - (2) Press [ RIGHT ] of Cursor button.

#### NOTE:

- If adjustment is cancelled with above procedure, adjustment is not completed. Make sure to adjust it later.
- Adjustment software “DIAS” is able to control the status of the adjustment flags.

### 9.3.2. Adjustment Specifications

The following matrix table shows the relation between the replaced part and the Necessary Adjustment.

When a part is replaced, make sure to perform the necessary adjustment(s) in the order indicated.

The table below shows all the information necessary to perform each adjustment.

| Adjustment order | Adjustment Item                                    | FLAG | Purpose  | Replacing Parts |                |                           |          |                       |                | JIG/TOOLS  | SET UP  | How to Operate  |
|------------------|--|------|--|-----------------|----------------|---------------------------|----------|-----------------------|----------------|--|---|---|
|                  |  |      |  | MAIN P.C.B      | VENUS (IC6001) | Lens part (Excluding CCD) | CCD UNIT | GYRO (IC7201, IC7301) | FeRAM (IC6003) |  |   |   |
| 1                | Initialization (IC6003)                            | —    | Initialization of FeRAM (After replacing the IC6003)                             | —               | —              | —                         | —        | —                     | ○              | <ul style="list-style-type: none"> <li>When replacing the FeRAM (IC6003), it is necessary to use the "Boot software" to allow the "Initialization".</li> <li>The "Boot software" is available at "TSN Website". To download, click on "Support Information from NWBG/VDBG-AVC".</li> </ul>   |   |   |
| 2                | Optical Tilt                                       | —    | Align the image sensor installation angle to the Lens.                           | —               | —              | ○                         | ○        | —                     | —              | NOTE:<br><ul style="list-style-type: none"> <li>It is necessary to use the "DSC_Tilt" software to allow the "Optical tilt adjustment".</li> <li>The Adjustment software "DSC_Tilt" is available at "TSN Website". To download, click on "Support Information from NWBG/VDBG-AVC".</li> </ul> |   |   |
| 3                | Venus Zoom   | PZM  | Venus Zoom Inspection  | ○               | ○              | —                         | —        | —                     | —              | NONE   | NONE  | 1) Press Shutter Button<br>2) After displaying "PZM", press Shutter Button again.<br>3) After completed, the "OK" menu appears.             |
| 4                | OIS sensor   | OIS  | OIS sensor output level adjustment   | ○               | ○              | ○                         | —        | —                     | —              | NONE   | NONE  | 1) Press Shutter Button (Do not apply any shock and vibration for the camera while adjusting)<br>2) After completed, the "OK" menu appears. |
| 5                | Backfocus / GYRO                                   | BF   | To have the focus tracking curve be appropriate shape and GYRO sensor adjustment | ○               | ○              | ○                         | ○        | ※1                    | ○              | • COLLIMATOR (VFK1164TCM02 or VFK1164TCM03 or RFKZ0422)  | 1) Set the camera in front of collimator so that the distance from collimator to camera becomes about 4.5 cm as shown in Fig. A.<br>[NOTE]<br>Please notice ! "NG" might happen while auto adjusting.<br>- Do not put the black colored stuff at the back side of collimator near hunching chart to get some certain brightness.<br>- Make sure the hunching chart has no dust and dirty condition.<br>- Not connect the USB cable at this stage. | 1) Press Shutter Button (Do not apply any shock and vibration for the camera while adjusting)<br>2) After completed, the "OK" menu appears. |
| 6                | Irs  | IRS  | Iris adjustment  | ○               | ○              | ○                         | ○        | —                     | —              | • LIGHT BOX (VFK1164TDVLB or RFKZ0523)   | 1) Set the camera in front of LIGHTBOX so that the distance from collimator to camera becomes about 7.5 cm as shown in Fig. B.  | 1) Press Shutter Button<br>2) After completed, the "OK" menu appears.   |
| 7                | Monitor Linearity                                  | MLN  | Monitor Linearity adjustment   | ○               | ○              | ○                         | ○        | —                     | —              | • LIGHT BOX (VFK1164TDVLB or RFKZ0523)<br>• TR CHART (RFKZ0443)  | 1) Press Shutter Button<br>2) After completed, the "OK" menu appears.   | 1) Press Shutter Button<br>2) After completed, the "OK" menu appears.   |
| 8                | Shutter  | SHT  | Shutter speed adjustment   | ○               | ○              | ○                         | ○        | —                     | —              | • LIGHT BOX (VFK1164TDVLB or RFKZ0523)<br>• TR CHART (RFKZ0443)  | 1) Insert the TR chart into the slot of LIGHTBOX.<br>2) Set the camera in front of LIGHTBOX so that the distance from LIGHTBOX to camera becomes about 1.3 cm as shown in Fig. B.<br>3) Set the camera angle so that the color chart is displayed on the LCD monitor fully.   | 1) Press Shutter Button<br>2) After completed, the "OK" menu appears.   |
| 9                | ISO  | ISO  | ISO sensitivity adjustment   | ○               | ○              | ○                         | ○        | —                     | —              | • LIGHT BOX (VFK1164TDVLB or RFKZ0523)<br>• TR CHART (RFKZ0443)  | [NOTE]<br>- Since the lens position is automatically set into certain position after executing auto adjustment, confirm the angle after stopping the lens zoom position.<br>- It is no problem even though the chart on to the LCD monitor slightly cut at the corner.<br>- It is no problem even though the focusing slightly becomes out of focusing condition.<br>- Not connect the USB cable at this stage.                                   | 1) Press Shutter Button<br>2) After completed, the "OK" menu appears.   |
| 10               | White Balance                                      | WBL  | White balance adjustment under various color temperature                         | ○               | ○              | ○                         | ○        | —                     | —              | • LIGHT BOX (VFK1164TDVLB or RFKZ0523)<br>• TR CHART (RFKZ0443)  | - Since the lens position is automatically set into certain position after executing auto adjustment, confirm the angle after stopping the lens zoom position.<br>- It is no problem even though the chart on to the LCD monitor slightly cut at the corner.<br>- It is no problem even though the focusing slightly becomes out of focusing condition.<br>- Not connect the USB cable at this stage.   | 1) Press Shutter Button<br>2) After completed, the "OK" menu appears.   |
| 11               | High brightness coloration                         | LIN  | High brightness coloration adjustment  | ○               | ○              | ○                         | ○        | —                     | —              | • LIGHT BOX (VFK1164TDVLB or RFKZ0523)<br>• TR CHART (RFKZ0443)  | - Since the lens position is automatically set into certain position after executing auto adjustment, confirm the angle after stopping the lens zoom position.<br>- It is no problem even though the chart on to the LCD monitor slightly cut at the corner.<br>- It is no problem even though the focusing slightly becomes out of focusing condition.<br>- Not connect the USB cable at this stage.   | 1) Press Shutter Button<br>2) After completed, the "OK" menu appears.   |
| 12               | CCD Missing Pixels (White)                         | WKI  | Compensation of CCD Missing Pixels (White)                                       | ○               | ○              | —                         | ○        | ※1                    | —              | NONE   | NONE  | 1) Press Shutter Button<br>2) After completed, the "OK" menu appears.   |
| 13               | Color reproduction inspection and Microphone check | COL  | Color reproduction inspection and Microphone check                               | ○               | ○              | ○                         | ○        | —                     | —              | NONE   | NONE  | 1) Press Shutter Button<br>2) After completed, the "OK" menu appears.   |
| 14               | CCD Missing Pixels (Black)                         | BKI  | Compensation of CCD Missing Pixels (Black)                                       | ○               | ○              | —                         | ○        | ※1                    | —              | • LIGHT BOX (VFK1164TDVLB or RFKZ0523)   | 1) Set the camera in front of LIGHTBOX so that the distance from collimator to camera becomes about 7.5 cm as shown in Fig. B.  | 1) Press Shutter Button<br>2) After completed, the "OK" menu appears.   |

- ※1: Execute the adjustment when remove the CCD unit and replace the CCD unit.
- ※2: The pixel that always lights while shaded is called a white wound.
- ※3: The pixel that does not light while complete exposed is called a black wound.
- \*This unit does not have the LCD adjustment of the camera (LCD flicker adjustment etc.).

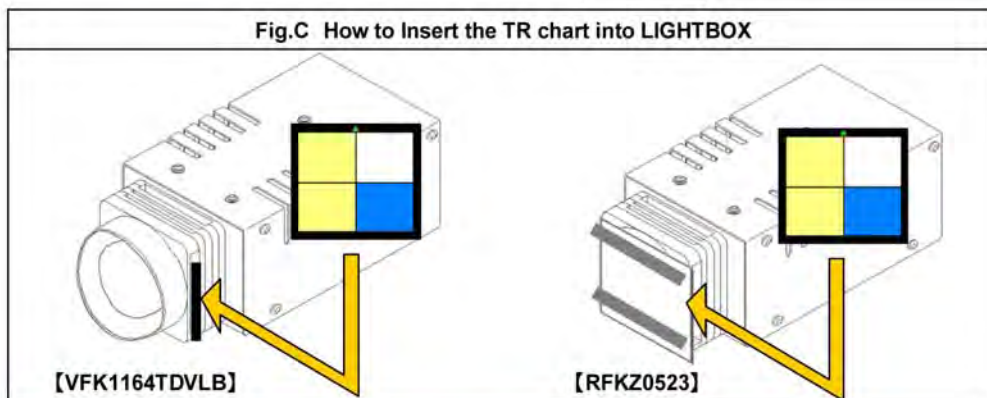
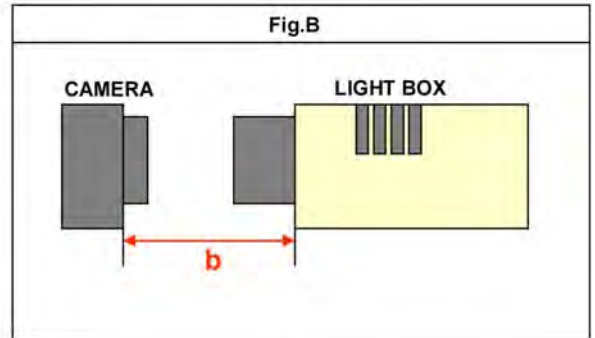
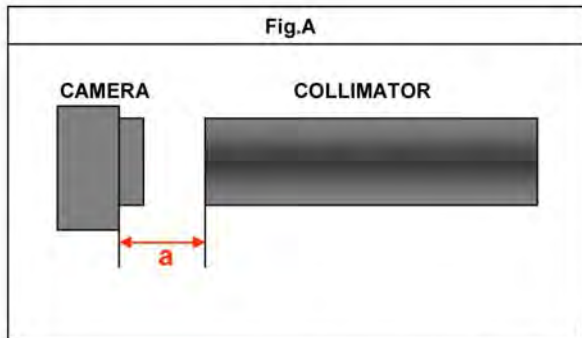

**IMPORTANT NOTICE (After replacing the MAIN P.C.B.)**  
 After replacing the MAIN P.C.B., make sure to perform the "INITIAL SETTINGS" first, then release the "INITIAL SETTINGS" in order to proceed the electrical adjustment.

**NOTE:**

- 1). If electrical adjustment or data re-writing is executed before "INITIAL SETTINGS", suffix code list is never displayed, and it cannot be chosen suitable suffix code.
- 2). Never remove the battery during initial setting in process.

## 9.4. After Adjustment

### 9.4.1. Initial Setting

Since the initial setting has been released to execute the built-in adjustment software, it should be set up again before shipping the camera to the customer.

Refer to the procedure described in "3.6.2. INITIAL SETTINGS" for details.

#### [ IMPORTANT ]

1. The initial setting should be done again after completing the alignment. Otherwise, the camera will not work properly.  
Therefore as a warning, the camera display a warning symbol " ! " on the LCD monitor every time the camera is turned off.
2. Confirm that status of all adjustment flag show "F". Even if one of the adjustment flag shows "0", initial setting programmed is never executed.
3. Adjustment software "DIAS" is able to control the status of the adjustment flags.  
The Adjustment software "DIAS" is available at "TSN Website", therefore, access to "TSN Website" at "Support Information from NWBG/VDBG-AVC".

# 10 Maintenance

## 10.1. Cleaning Lens and LCD Panel

Do not touch the surface of lens and LCD Panel with your hand.

When cleaning the lens, use air-Blower to blow off the dust.

When cleaning the LCD Panel, dampen the lens cleaning paper with lens cleaner, and the gently wipe the its surface.

**Note:**

The Lens Cleaning KIT ; VFK1900BK (Only supplied as 10 set/Box) is available as Service Aid.

# Service Manual

---

## Diagrams and Replacement Parts List

### Digital Camera

Model No.

|           |           |
|-----------|-----------|
| DMC-LX5P  | DMC-LX5GC |
| DMC-LX5PC | DMC-LX5GD |
| DMC-LX5PU | DMC-LX5GK |
| DMC-LX5EB | DMC-LX5GN |
| DMC-LX5EE | DMC-LX5GT |
| DMC-LX5EF | DMC-LX5SG |
| DMC-LX5EG |           |
| DMC-LX5EP |           |

Vol. 1  
 Colour  
 (K).....Black Type  
 (W).....White Type (only P/GC/GD/GK/GN/GT)

### Table of contents

|  |     |   |      |
|--|-----|---|------|
| S1. About Indication of The Schematic Diagram..... | S-1 | S5. Print Circuit Board.....                          | S-10 |
| S1.1. Important Safety Notice.....                 | S-1 | S5.1. Gyro P.C.B. ....                                | S-10 |
| S2. Voltage Chart .....                            | S-2 | S5.2. BAT P.C.B.....                                  | S-10 |
| S2.1. Gyro P.C.B. ....                             | S-2 | S5.3. LVF P.C.B.....                                  | S-11 |
| S2.2. BAT P.C.B.....                               | S-2 | S5.4. Flash P.C.B. ....                               | S-12 |
| S2.3. Flash P.C.B. ....                            | S-2 | S5.5. Top P.C.B. ....                                 | S-13 |
| S2.4. Top P.C.B. ....                              | S-2 | S5.5.1. Top P.C.B. (Component Side) .....             | S-13 |
| S3. Block Diagram.....                             | S-3 | S5.5.2. Top P.C.B. (Foil Side).....                   | S-14 |
| S3.1. Overall Block Diagram .....                  | S-3 | S5.6. CCD Flex P.C.B.....                             | S-15 |
| S4. Schematic Diagram.....                         | S-4 | S6. Replacement Parts List.....                       | S-17 |
| S4.1. Interconnection Diagram.....                 | S-4 | S7. Exploded View .....                               | S-23 |
| S4.2. Gyro Schematic Diagram .....                 | S-5 | S7.1. Frame and Casing Section.....                   | S-23 |
| S4.3. BAT Schematic Diagram .....                  | S-5 | S7.2. Camera Lens Section.....                        | S-24 |
| S4.4. EXT LVF Schematic Diagram .....              | S-6 | S7.3. Packing Parts and Accessories Section (1) ..... | S-25 |
| S4.5. Flash Schematic Diagram .....                | S-7 | S7.4. Packing Parts and Accessories Section (2) ..... | S-26 |
| S4.6. Top Schematic Diagram .....                  | S-8 |   |      |
| S4.7. CCD Flex Schematic Diagram .....             | S-9 |   |      |

## S1. About Indication of The Schematic Diagram

### S1.1. Important Safety Notice

COMPONENTS IDENTIFIED WITH THE MARK  $\triangle$  HAVE THE SPECIAL CHARACTERISTICS FOR SAFETY. WHEN REPLACING ANY OF THESE COMPONENTS USE ONLY THE SAME TYPE.

1. Although reference number of the parts is indicated on the P.C.B. drawing and/or schematic diagrams, it is NOT mounted on the P.C.B. when it is displayed with "\$" mark.
2. It is only the "Test Round" and no terminal (Pin) is available on the P.C.B. when the TP (Test Point) indicated as "●" mark.
3. The voltage being indicated on the schematic diagram is measured in "Standard-Playback" mode when there is no specify mode is mentioned.
4. Although the voltage and waveform available on here is measured with standard frame, it may be differ from actual measurement due to modification of circuit and so on.
5. The voltage being indicated here may be include observational-error (deviation) due to internal-resistance and/or reactance of equipment. Therefore, handle the value indicated on here as reference.
6. Use the parts number indicated on the Replacement Parts List .
7. Indication on Schematic diagrams:

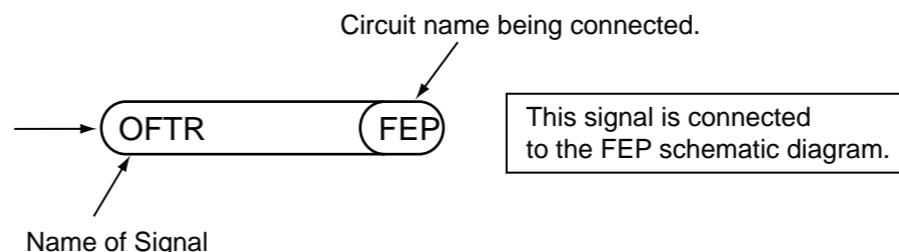

## S2. Voltage Chart

Note) Indicated voltage values are the standard values for the unit measured by the DC electronic circuit tester (high-impedance) with the chassis taken as standard.  
Therefore, there may exist some errors in the voltage values, depending on the internal impedance of the DC circuit tester.

### S2.1. Gyro P.C.B.

| REF No. | PIN No. | POWER ON |
|---------|---------|----------|
| IC7201  | 1       | -        |
| IC7201  | 2       | -        |
| IC7201  | 3       | -        |
| IC7201  | 4       | 0        |
| IC7201  | 5       | 0        |
| IC7201  | 6       | 0        |
| IC7201  | 7       | 0        |
| IC7201  | 8       | 3.1      |

### S2.2. BAT P.C.B.

| REF No. | PIN No. | POWER ON |
|---------|---------|----------|
| IC7301  | 1       | -        |
| IC7301  | 2       | -        |
| IC7301  | 3       | -        |
| IC7301  | 4       | 0        |
| IC7301  | 5       | 1.4      |
| IC7301  | 6       | 1.4      |
| IC7301  | 7       | 0        |
| IC7301  | 8       | 3.1      |

### S2.3. Flash P.C.B.

| REF No. | PIN No. | POWER ON |
|---------|---------|----------|
| IC8001  | 1       | 0        |
| IC8001  | 2       | 0        |
| IC8001  | 3       | 0        |
| IC8001  | 4       | 0        |
| IC8001  | 5       | 3.6      |
| IC8001  | 6       | 0        |
| IC8001  | 7       | 0        |
| IC8001  | 8       | 0        |
| IC8001  | 9       | 3.1      |
| IC8001  | 10      | 4        |
| IC8501  | 1       | -        |
| IC8501  | 2       | 0        |
| IC8501  | 3       | 3        |
| IC8501  | 4       | 3        |

### S2.4. Top P.C.B.

| REF No. | PIN No. | POWER ON |
|---------|---------|----------|
| Q9951   | S       | 0        |
| Q9951   | D       | 3        |
| Q9951   | G       | 0        |

# S3. Block Diagram

## S3.1. Overall Block Diagram

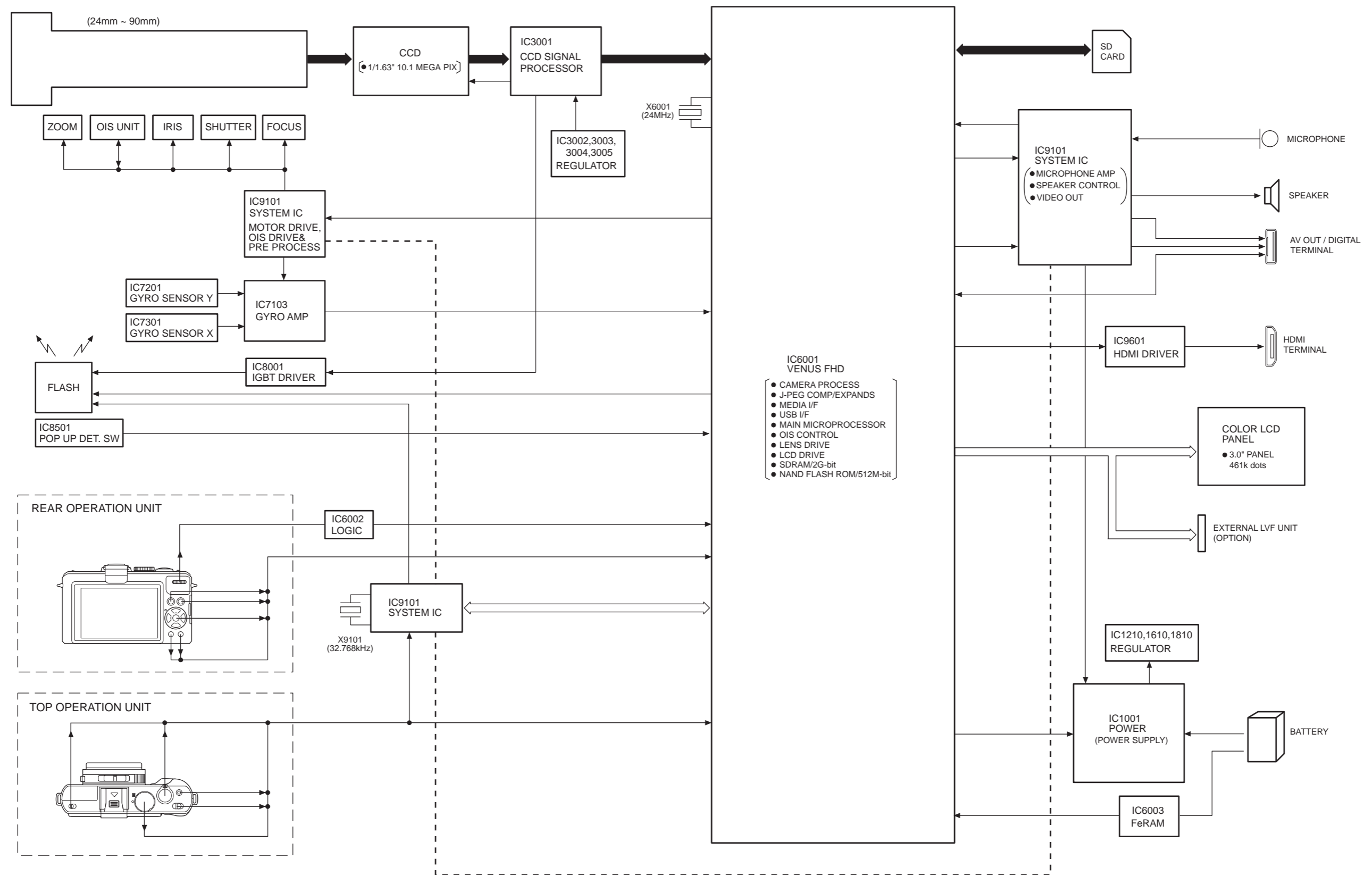

DMC-LX5 OVERALL BLOCK DIAGRAM

# S4. Schematic Diagram

## S4.1. Interconnection Diagram

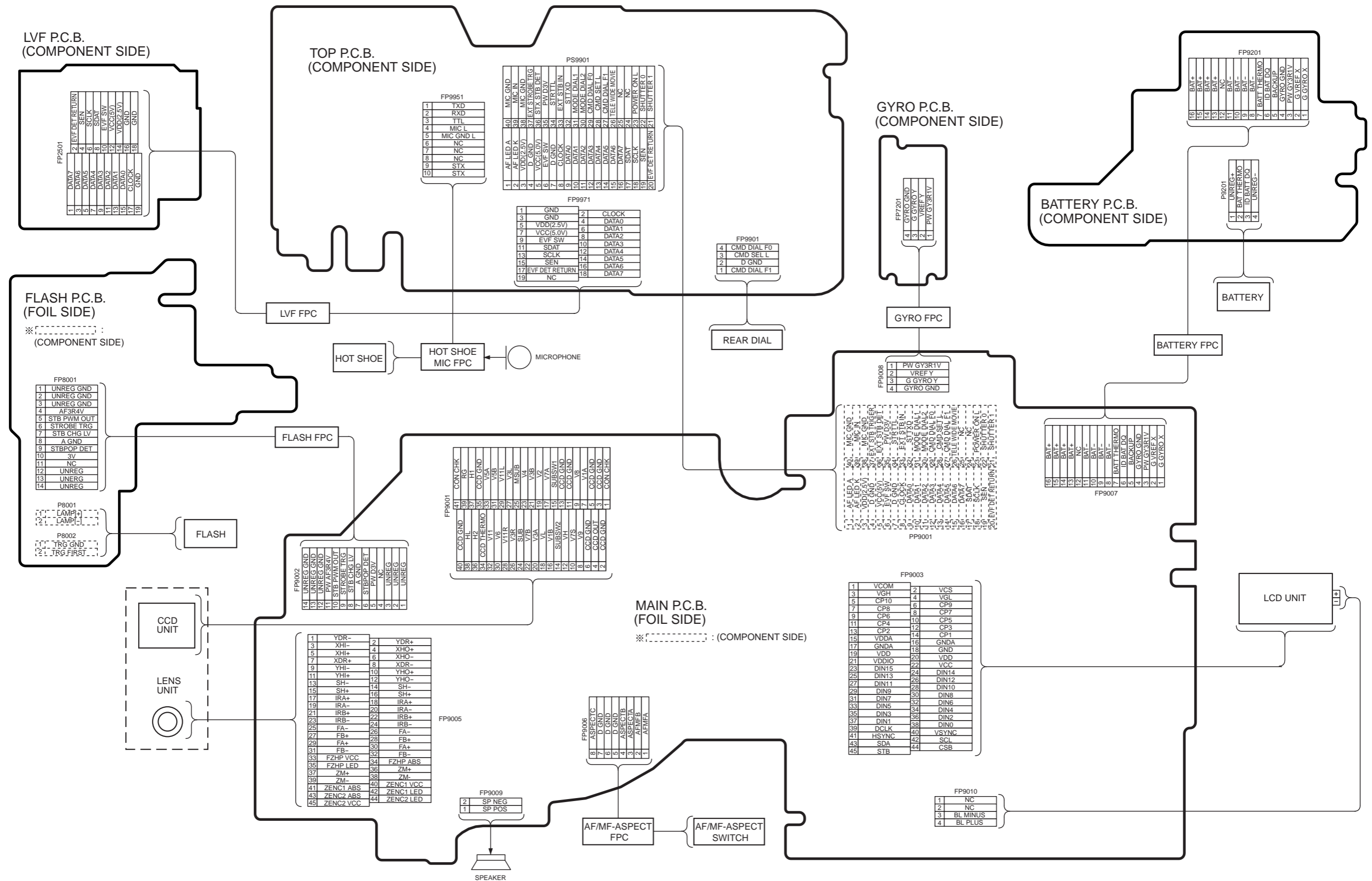

## S4.2. Gyro Schematic Diagram / S4.3. BAT Schematic Diagram

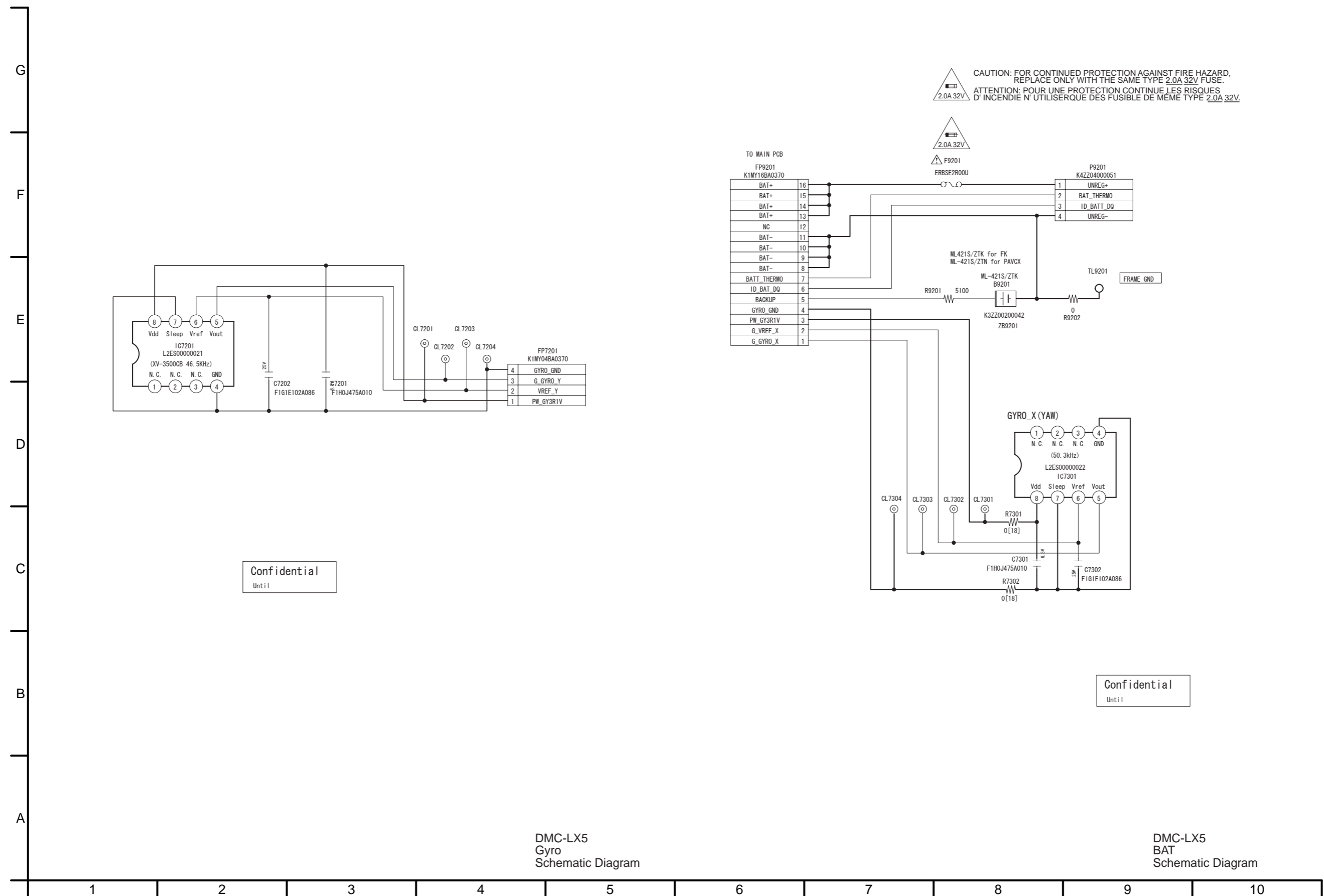

DMC-LX5  
Gyro  
Schematic Diagram

DMC-LX5  
BAT  
Schematic Diagram

# S4.4. EXT LVF Schematic Diagram

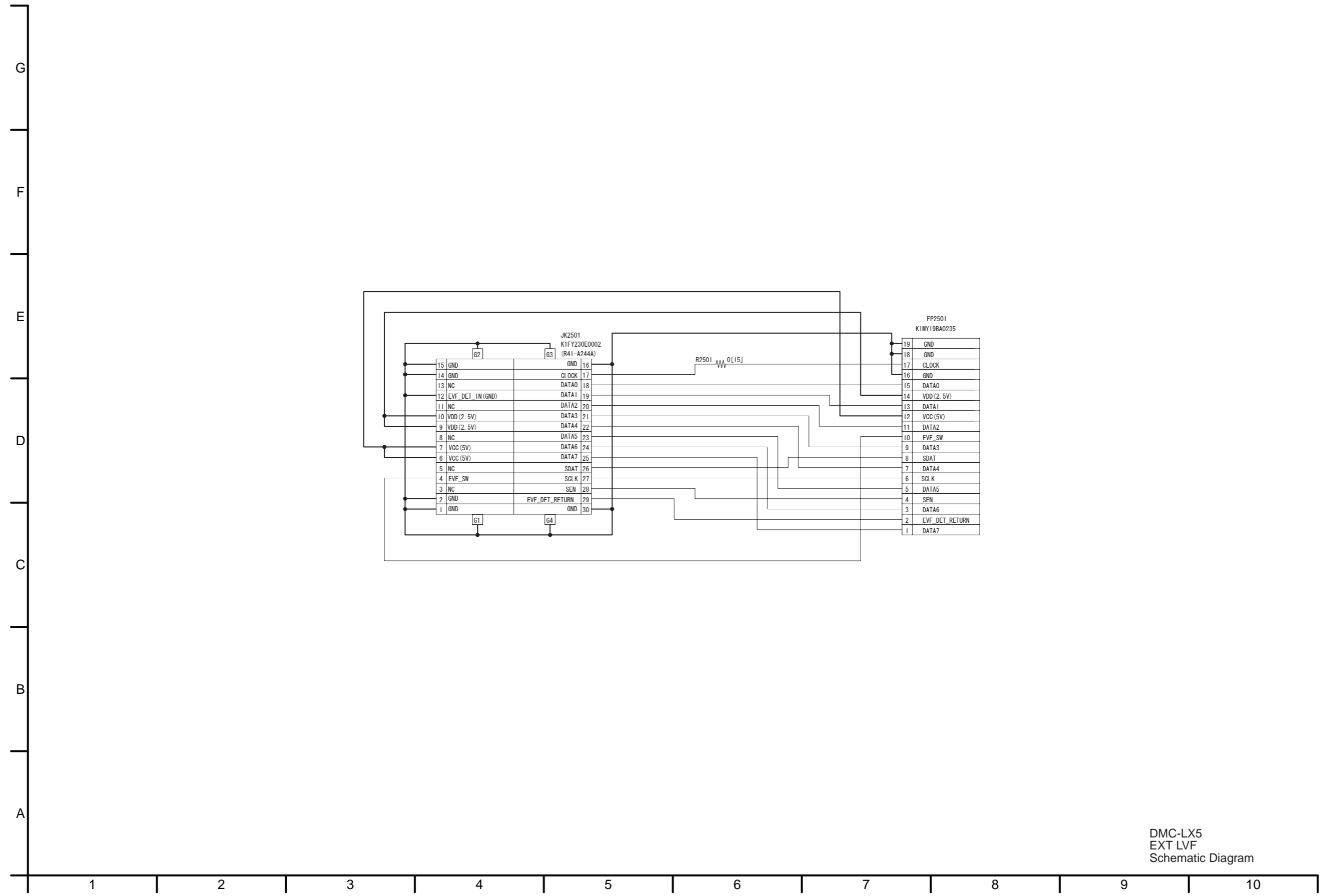

DMC-LX5  
EXT LVF  
Schematic Diagram

# S4.5. Flash Schematic Diagram

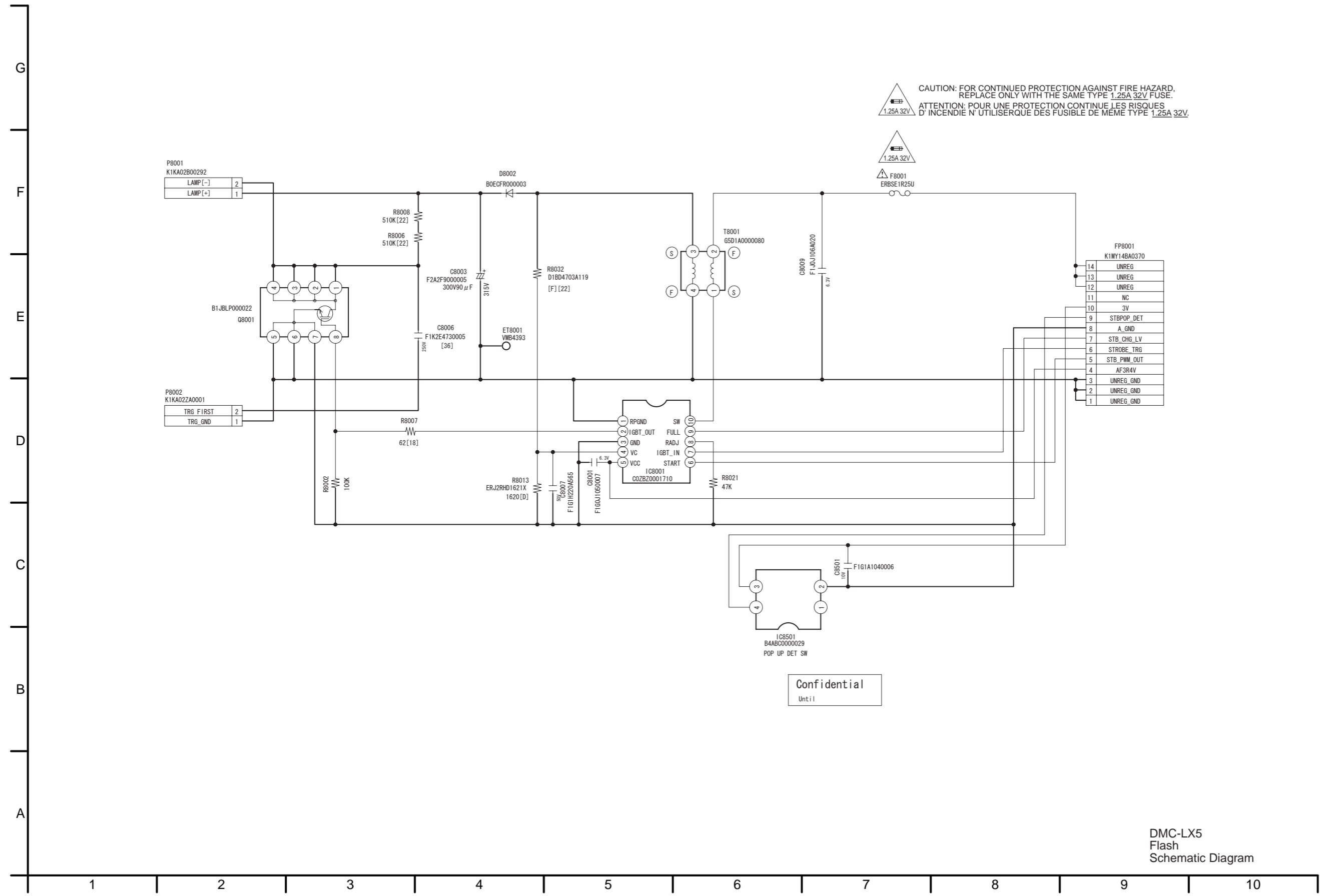

Confidential  
Until

# S4.6. Top Schematic Diagram

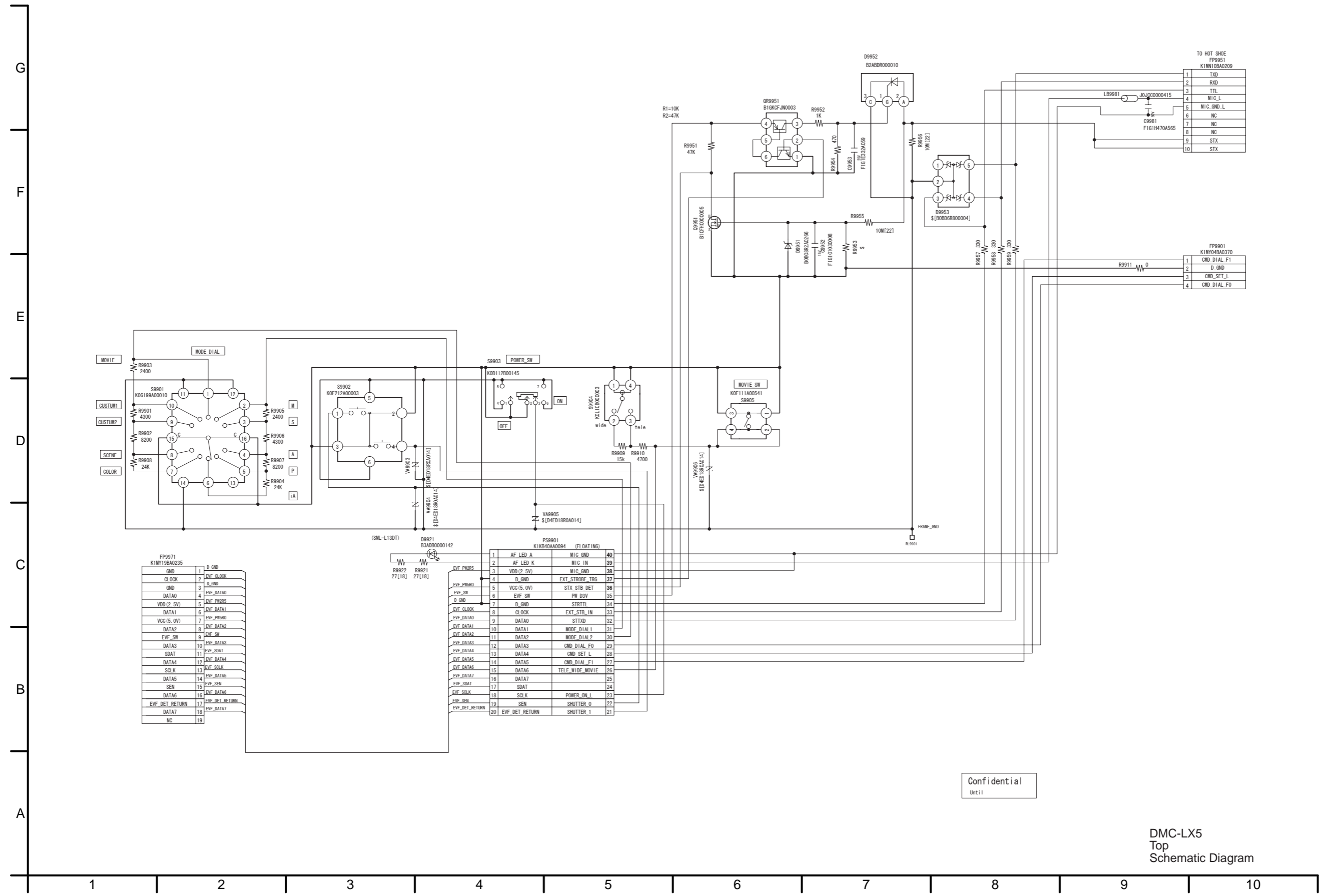

Confidential  
Unit 1

DMC-LX5  
Top  
Schematic Diagram

# S4.7. CCD Flex Schematic Diagram

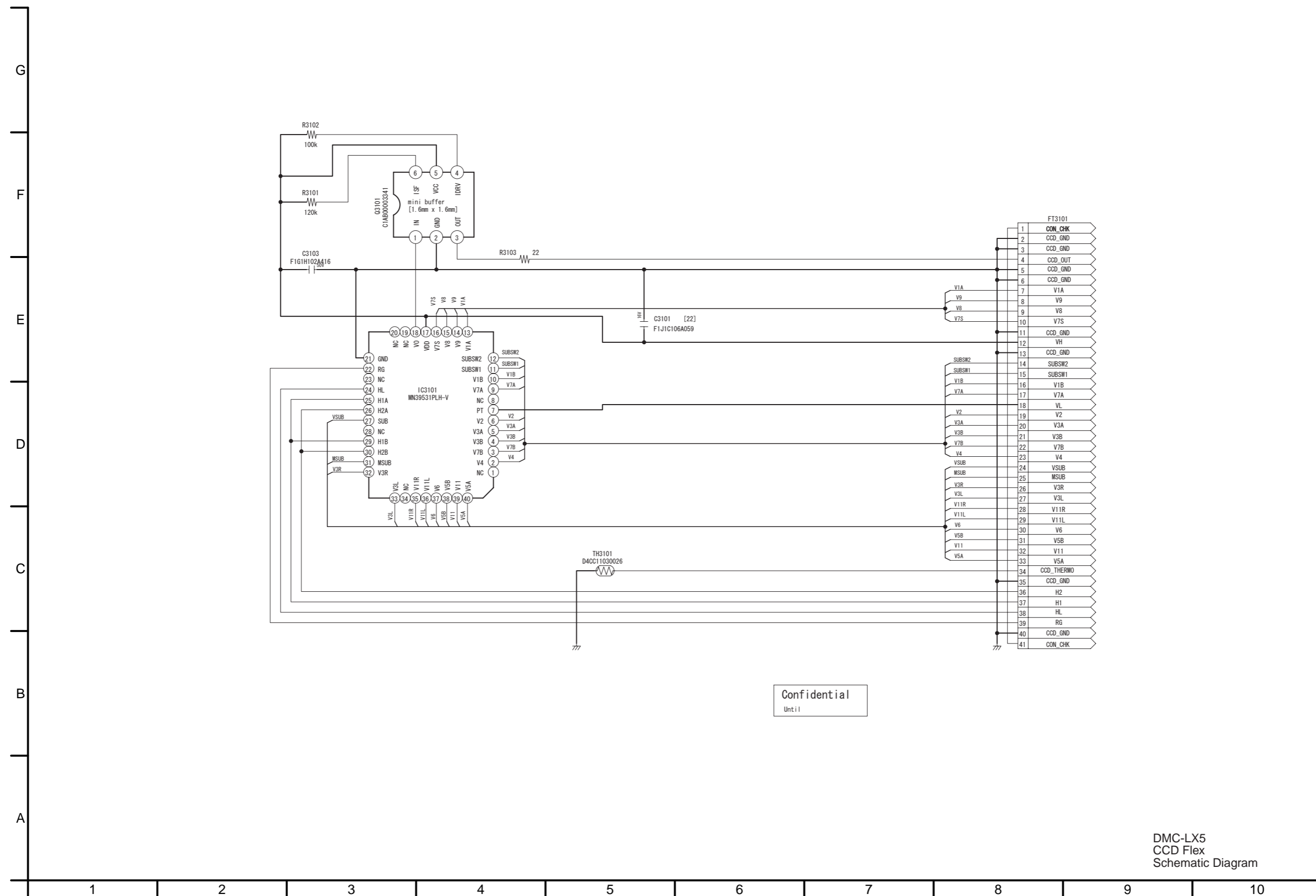

Confidential  
Until

# S5. Print Circuit Board

## S5.1. Gyro P.C.B. / S5.2. BAT P.C.B.

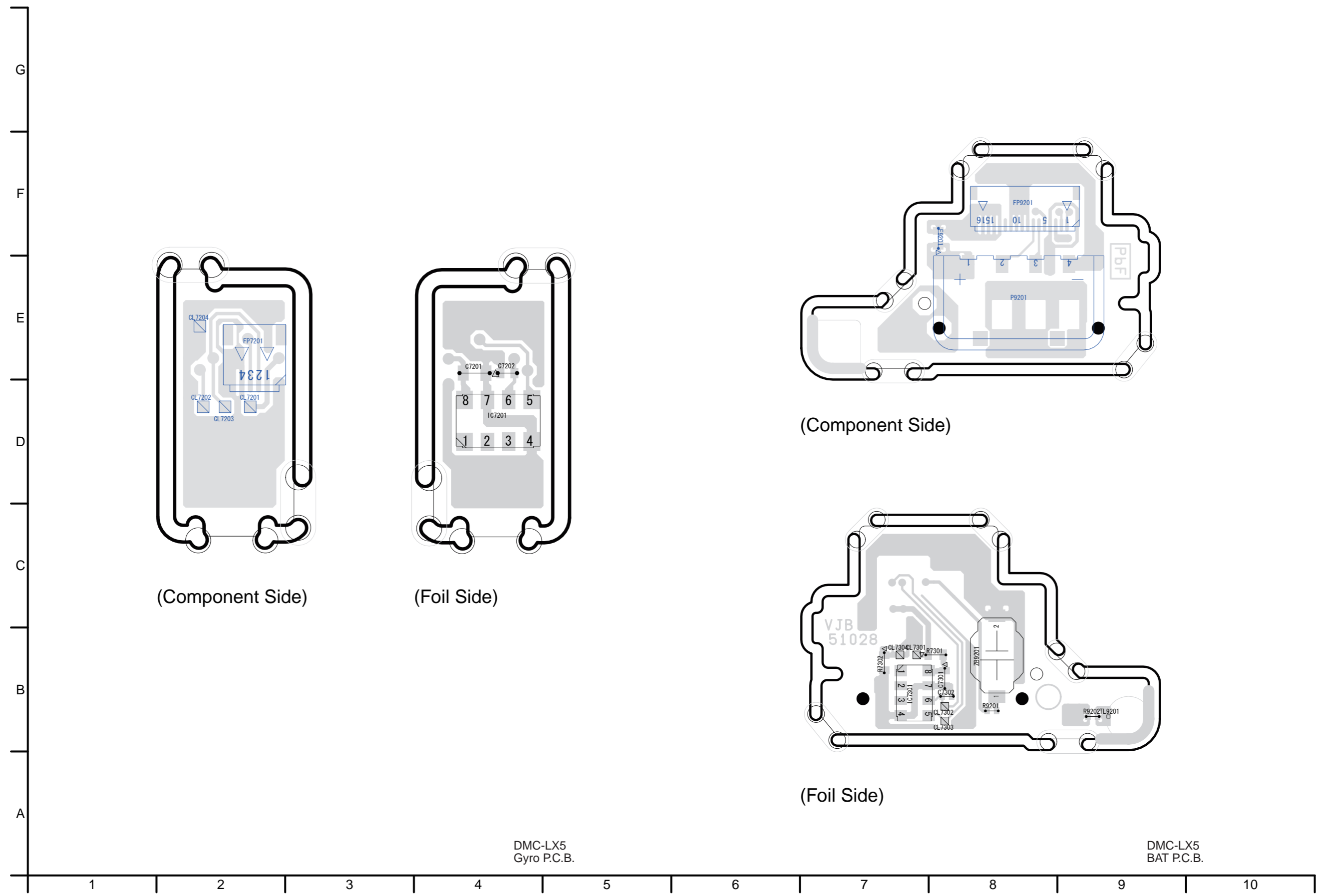

DMC-LX5 Gyro P.C.B.

DMC-LX5 BAT P.C.B.

S5.3. LVF P.C.B.

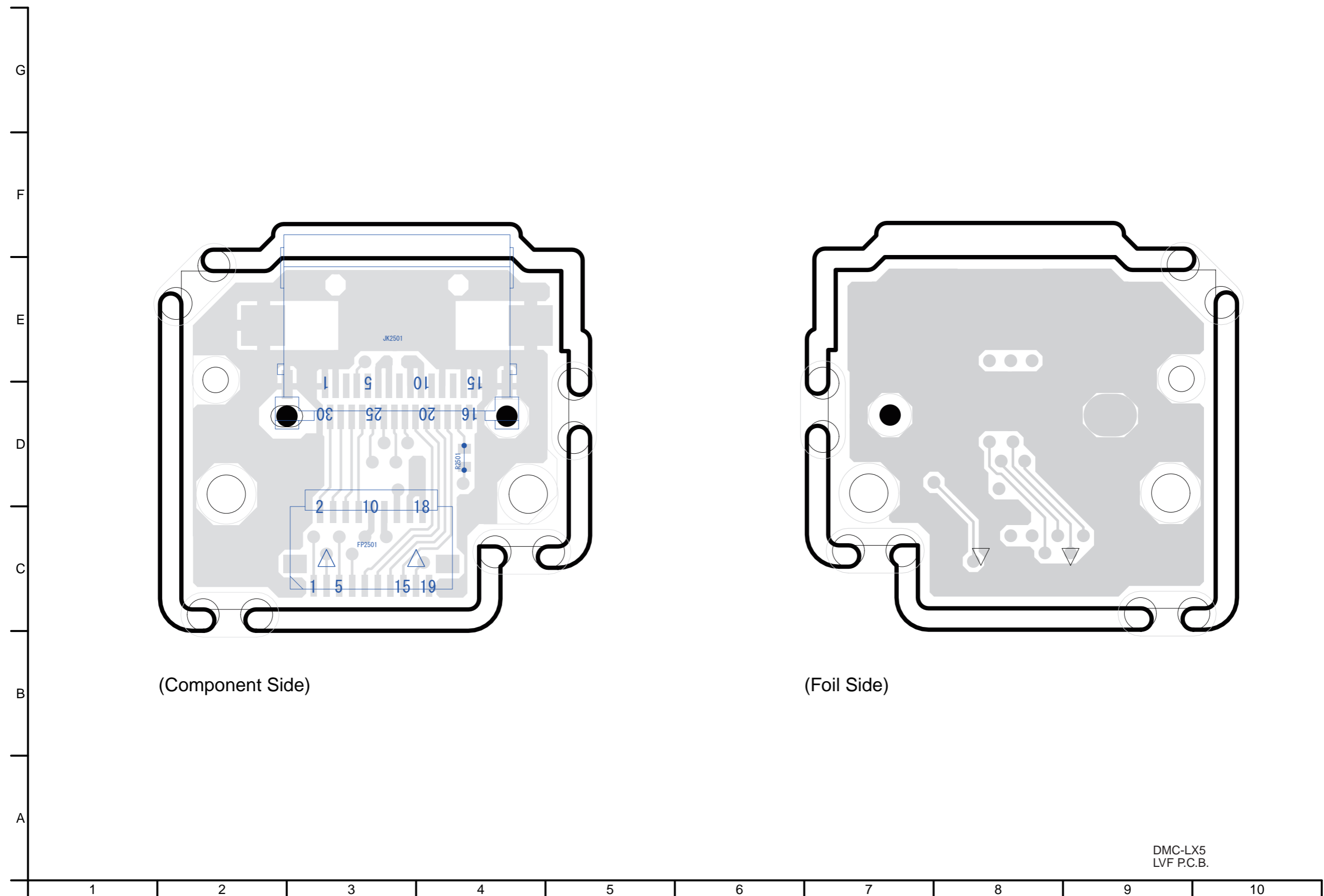

(Component Side)

(Foil Side)

DMC-LX5  
LVF P.C.B.

S5.4. Flash P.C.B.

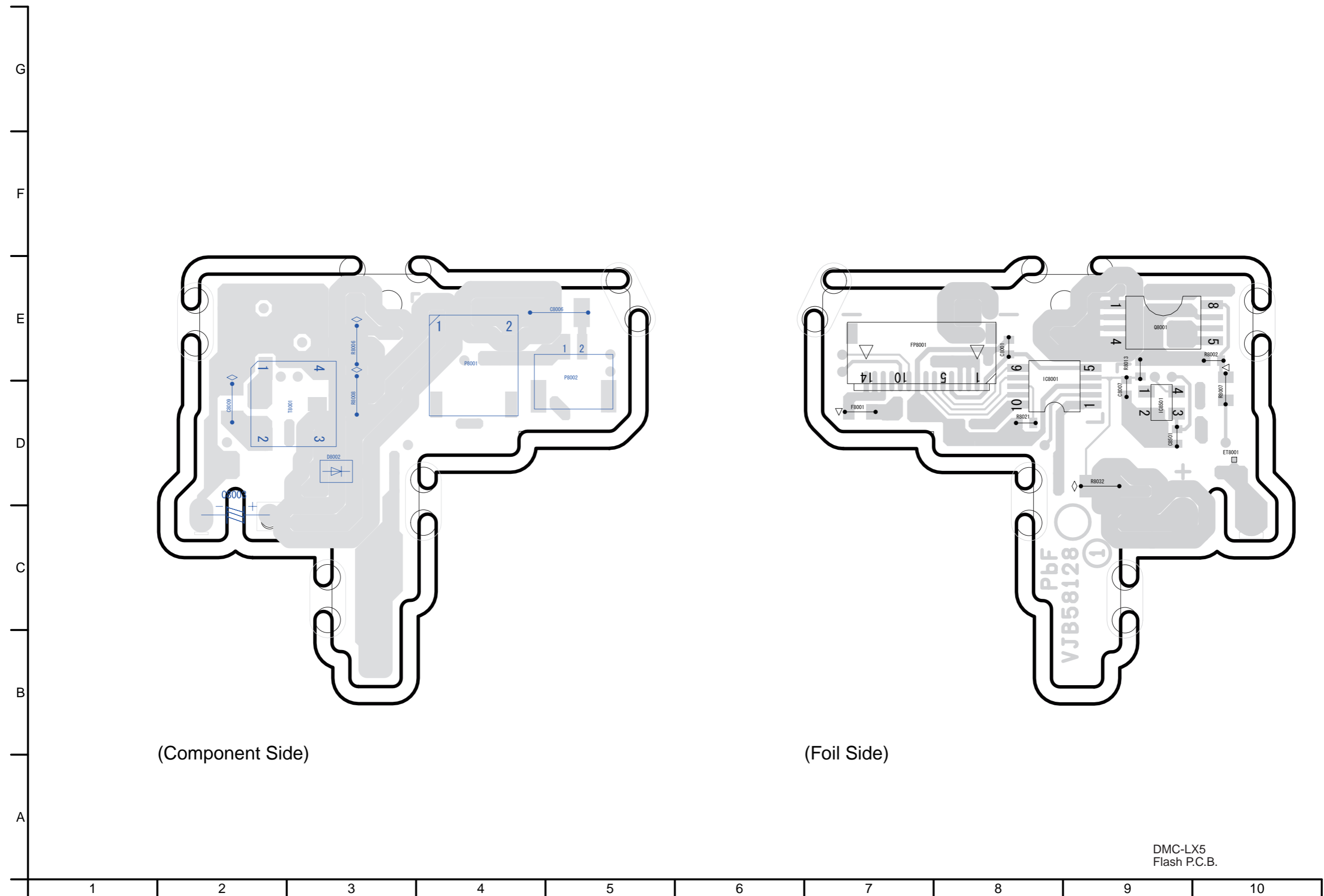



S5.5.2. Top P.C.B. (Foil Side)

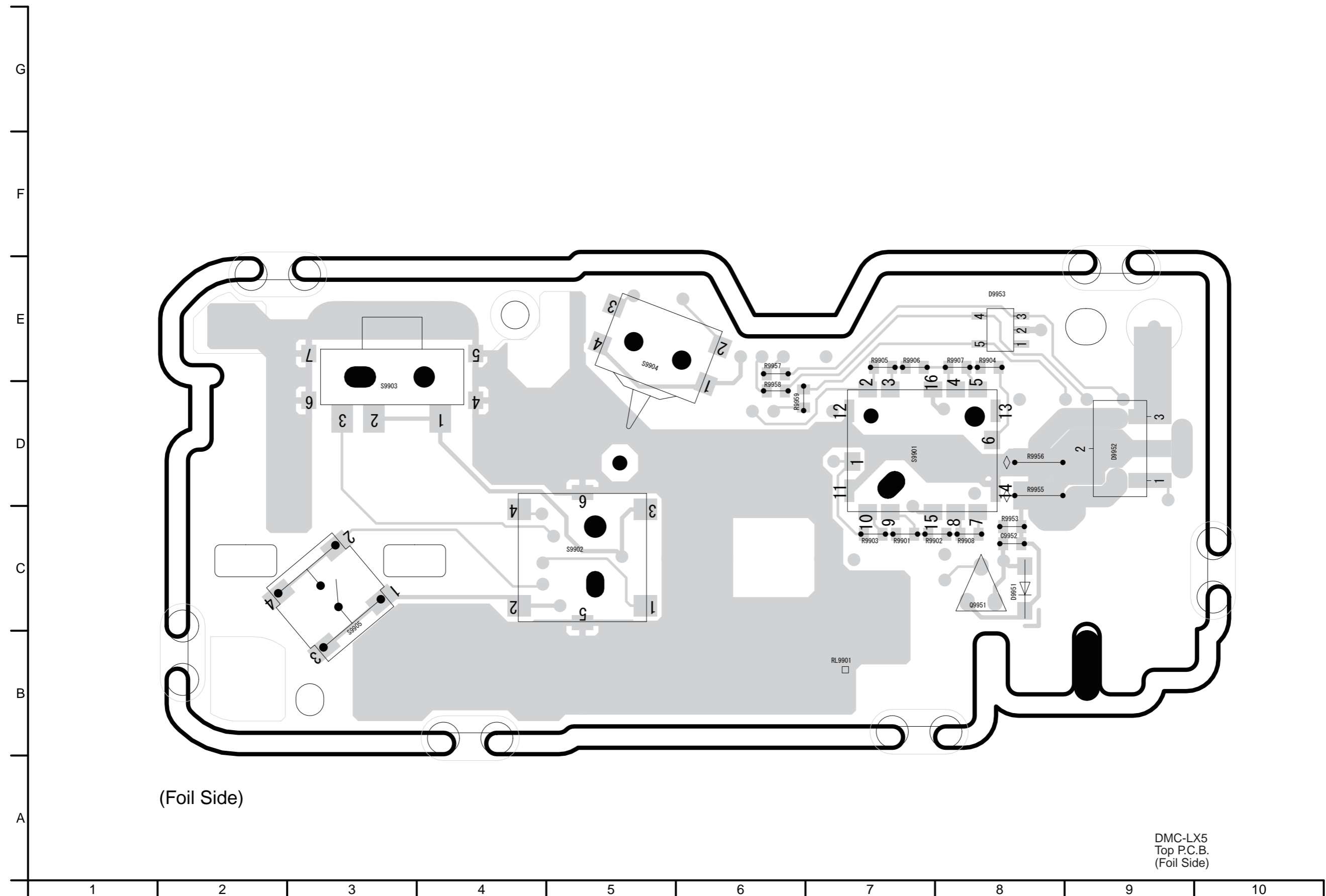

S5.6. CCD Flex P.C.B.

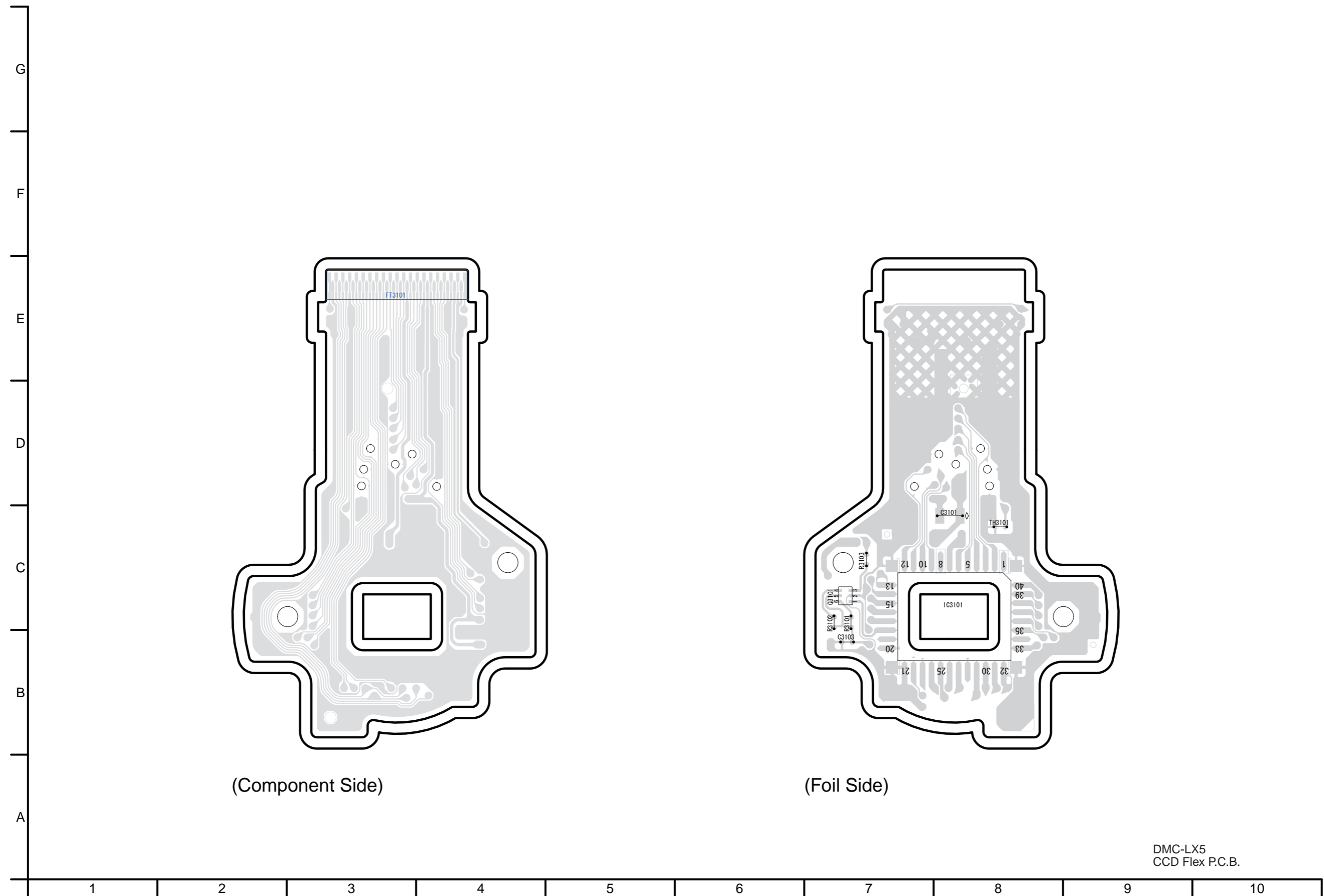

DMC-LX5  
CCD Flex P.C.B.



## S6. Replacement Parts List

- Note:
1. \* Be sure to make your orders of replacement parts according to this list.
  2. **IMPORTANT SAFETY NOTICE**  
Components identified with the mark  have the special characteristics for safety.  
When replacing any of these components, use only the same type.
  3. Unless otherwise specified,  
All resistors are in OHMS, K=1,000 OHMS. All capacitors are in MICRO-FARADS (uf), P=uuF.
  4. The marking (RTL) indicates the retention time is limited for this item. After the discontinuation of this assembly in production, it will no longer be available.
  5. Supply of CD-ROM, in accordance with license protection, is allowable as replacement parts only for customers who accidentally damaged or lost their own.

**E.S.D. standards for Electrostatically Sensitive Devices, refer to PREVENTION OF ELECTROSTATIC DISCHARGE (ESD) TO ELECTROSTATICALLY SENSITIVE (ES) DEVICES section.**

**Definition of Parts supplier:**

1. **Parts marked with [ENERGY] in the remarks column are supplied from Panasonic Corporation Energy Company.**
2. **Parts marked with [PAVCSG] in the remarks column are supplied from PAVCSG. Others are supplied from AVC-CSC-SPC.**

| Ref.No. | Part No.     | Part Name & Description  | Pcs | Remarks                           |
|---------|--------------|--------------------------|-----|-----------------------------------|
| ##      | VEP56112A    | MAIN P.C.B.              | 1   | (EXCEPT EG,EP,EF,EB) (RTL) E.S.D. |
| ##      | VEP56112B    | MAIN P.C.B.              | 1   | EG,EP,EF,EB (RTL) E.S.D.          |
| ##      | VEP50067A    | GYRO P.C.B.              | 1   | (RTL) E.S.D.                      |
| ##      | VEP51028A    | BATTERY P.C.B.           | 1   | (RTL) E.S.D.                      |
| ##      | VEP59089A    | LVF P.C.B.               | 1   | (RTL) [PAVCSG] E.S.D.             |
| ##      | VEP58128A    | FLASH P.C.B.             | 1   | (RTL) [PAVCSG] E.S.D.             |
| ##      | VEP59088A    | TOP P.C.B.               | 1   | (RTL) [PAVCSG] E.S.D.             |
| ##      | VEK0R03      | CCD UNIT                 | 1   |                                   |
| ##      | VEP50067A    | GYRO P.C.B.              |     | (RTL) E.S.D.                      |
| C7201   | F1H0J475A010 | C.CAPACITOR CH 6.3V 4.7U | 1   |                                   |
| C7202   | F1G1H1020008 | C.CAPACITOR CH 50V 1000P | 1   |                                   |
| FP7201  | K1MY04BA0370 | CONNECTOR 4P             | 1   |                                   |
| IC7201  | L2ES00000021 | IC                       | 1   | E.S.D.                            |
| ##      | VEP51028A    | BATTERY P.C.B.           |     | (RTL) E.S.D.                      |
| C7301   | F1H0J475A010 | C.CAPACITOR CH 6.3V 4.7U | 1   |                                   |
| C7302   | F1G1H1020008 | C.CAPACITOR CH 50V 1000P | 1   |                                   |
| △ F9201 | ERBSE2R00U   | FUSE 32V 2.0A            | 1   |                                   |
| FP9201  | K1MY16BA0370 | CONNECTOR 16P            | 1   |                                   |
| IC7301  | L2ES00000022 | IC                       | 1   | E.S.D.                            |
| P9201   | K4ZZ04000051 | CONNECTOR 4P             | 1   |                                   |
| R7301   | ERJ3GEY0R00  | M.RESISTOR CH 1/10W 0    | 1   |                                   |
| R7302   | ERJ3GEY0R00  | M.RESISTOR CH 1/10W 0    | 1   |                                   |
| R9201   | ERJ2GEJ512X  | M.RESISTOR CH 1/16W 5.1K | 1   |                                   |
| R9202   | D0YAR0000007 | M.RESISTOR CH 1/10W 0    | 1   |                                   |
| ZB9201  | K3ZZ00200042 | BATTERY HOLDER           | 1   |                                   |
| ##      | VEP59089A    | LVF P.C.B.               |     | (RTL) [PAVCSG] E.S.D.             |
| FP2501  | K1MY19BA0235 | CONNECTOR 19P            | 1   | [PAVCSG]                          |
| JK2501  | K1FY230E0002 | JACK                     | 1   | [PAVCSG]                          |
| R2501   | ERJ2GE0R00X  | M.RESISTOR CH 1/16W 0    | 1   | [PAVCSG]                          |
| ##      | VEP58128A    | FLASH P.C.B.             |     | (RTL) [PAVCSG] E.S.D.             |
| C8001   | F1G0J1050007 | C.CAPACITOR CH 6.3V 1U   | 1   | [PAVCSG]                          |
| C8006   | F1K2E4730005 | C.CAPACITOR 250V 0.047U  | 1   | [PAVCSG]                          |
| C8007   | F1G1H220A565 | C.CAPACITOR CH 50V 22P   | 1   | [PAVCSG]                          |
| C8009   | F1J0J106A020 | C.CAPACITOR CH 6.3V 10U  | 1   | [PAVCSG]                          |
| C8501   | F1G1A1040006 | C.CAPACITOR CH 10V 0.1U  | 1   | [PAVCSG]                          |
| D8002   | B0ECFR000003 | DIODE                    | 1   | [PAVCSG] E.S.D.                   |
| △ F8001 | ERBSE1R25U   | FUSE 32V 1.25A           | 1   | [PAVCSG]                          |
| FP8001  | K1MY14BA0370 | CONNECTOR 14P            | 1   | [PAVCSG]                          |
| IC8001  | C0ZB20001710 | IC                       | 1   | [PAVCSG] E.S.D.                   |
| IC8501  | B4ABC0000029 | IC                       | 1   | [PAVCSG] E.S.D.                   |
| P8001   | K1KA02B00292 | CONNECTOR 2P             | 1   | [PAVCSG]                          |
| P8002   | K1KA02ZA0001 | CONNECTOR 2P             | 1   | [PAVCSG]                          |
| Q8001   | B1JBLP000022 | TRANSISTOR               | 1   | [PAVCSG] E.S.D.                   |

| Ref.No. | Part No.     | Part Name & Description  | Pcs | Remarks               |
|---------|--------------|--------------------------|-----|-----------------------|
| R8002   | ERJ2GEJ104X  | M.RESISTOR CH 1/16W 100K | 1   | [PAVCSG]              |
| R8006   | ERJ6GEYJ514V | M.RESISTOR CH 1/10W 514K | 1   | [PAVCSG]              |
| R8007   | ERJ3GEYJ620V | M.RESISTOR CH 1/10W 62   | 1   | [PAVCSG]              |
| R8008   | ERJ6GEYJ514V | M.RESISTOR CH 1/10W 514K | 1   | [PAVCSG]              |
| R8013   | ERJ2RHD1621X | M.RESISTOR CH W K        | 1   | [PAVCSG]              |
| R8021   | ERJ2GEJ473X  | M.RESISTOR CH 1/16W 47K  | 1   | [PAVCSG]              |
| R8032   | D1BD4703A119 | RESISTOR                 | 1   | [PAVCSG]              |
| T8001   | G5D1A0000080 | TRANSFORMER              | 1   | [PAVCSG]              |
| ##      | VEP59088A    | TOP P.C.B.               |     | (RTL) [PAVCSG] E.S.D. |
| C9952   | F1G1C1030008 | C.CAPACITOR CH 16V 0.01U | 1   | [PAVCSG]              |
| C9953   | F1G1E332A059 | C.CAPACITOR CH 25V 3300P | 1   | [PAVCSG]              |
| C9981   | F1G1H470A565 | C.CAPACITOR CH 50V 47P   | 1   | [PAVCSG]              |
| D9921   | B3ADB0000142 | DIODE                    | 1   | [PAVCSG] E.S.D.       |
| D9951   | B0BC8R2A0266 | DIODE                    | 1   | [PAVCSG] E.S.D.       |
| D9952   | B2ABDR000010 | DIODE                    | 1   | [PAVCSG] E.S.D.       |
| FP9901  | K1MY04BA0370 | CONNECTOR 4P             | 1   | [PAVCSG]              |
| FP9951  | K1MN10BA0209 | CONNECTOR 10P            | 1   | [PAVCSG]              |
| FP9971  | K1MY19BA0235 | CONNECTOR 19P            | 1   | [PAVCSG]              |
| LB9981  | J0JCC0000415 | FILTER                   | 1   | [PAVCSG]              |
| PS9901  | K1KB40AA0094 | CONNECTOR 40P            | 1   | [PAVCSG]              |
| Q9951   | B1CFHC000005 | TRANSISTOR               | 1   | [PAVCSG] E.S.D.       |
| QR9951  | B1GKCFJN0003 | TRANSISTOR-RESISTOR      | 1   | [PAVCSG] E.S.D.       |
| R9901   | ERJ2GEJ432X  | M.RESISTOR CH 1/10W 4.3K | 1   | [PAVCSG]              |
| R9902   | ERJ2GEJ822X  | M.RESISTOR CH 1/10W 8.2K | 1   | [PAVCSG]              |
| R9903   | ERJ2GEJ242X  | M.RESISTOR CH 1/16W 2.4K | 1   | [PAVCSG]              |
| R9904   | ERJ2GEJ243X  | M.RESISTOR CH 1/16W 24K  | 1   | [PAVCSG]              |
| R9905   | ERJ2GEJ242X  | M.RESISTOR CH 1/16W 2.4K | 1   | [PAVCSG]              |
| R9906   | ERJ2GEJ432X  | M.RESISTOR CH 1/10W 4.3K | 1   | [PAVCSG]              |
| R9907   | ERJ2GEJ822X  | M.RESISTOR CH 1/10W 8.2K | 1   | [PAVCSG]              |
| R9908   | ERJ2GEJ243X  | M.RESISTOR CH 1/16W 24K  | 1   | [PAVCSG]              |
| R9909   | ERJ2GEJ153X  | M.RESISTOR CH 1/16W 15K  | 1   | [PAVCSG]              |
| R9910   | ERJ2GEJ472X  | M.RESISTOR CH 1/10W 4.7K | 1   | [PAVCSG]              |
| R9911   | ERJ2GE0R00X  | M.RESISTOR CH 1/16W 0    | 1   | [PAVCSG]              |
| R9921   | ERJ3GEYJ270V | M.RESISTOR CH 1/10W 27   | 1   | [PAVCSG]              |
| R9922   | ERJ3GEYJ270V | M.RESISTOR CH 1/10W 27   | 1   | [PAVCSG]              |
| R9951   | ERJ2GEJ473X  | M.RESISTOR CH 1/16W 47K  | 1   | [PAVCSG]              |
| R9952   | ERJ2GEJ102X  | M.RESISTOR CH 1/16W 1K   | 1   | [PAVCSG]              |
| R9954   | ERJ2GEJ471X  | M.RESISTOR CH 1/10W 470  | 1   | [PAVCSG]              |
| R9955   | ERJ6GEYJ106V | M.RESISTOR CH 1/10W 10M  | 1   | [PAVCSG]              |
| R9956   | ERJ6GEYJ106V | M.RESISTOR CH 1/10W 10M  | 1   | [PAVCSG]              |
| R9957   | ERJ2GEJ331X  | M.RESISTOR CH 1/16W 330  | 1   | [PAVCSG]              |
| R9958   | ERJ2GEJ331X  | M.RESISTOR CH 1/16W 330  | 1   | [PAVCSG]              |
| R9959   | ERJ2GEJ331X  | M.RESISTOR CH 1/16W 330  | 1   | [PAVCSG]              |
| S9901   | K0G199A00010 | SWITCH                   | 1   | [PAVCSG]              |
| S9902   | K0F212A00003 | SWITCH                   | 1   | [PAVCSG]              |
| S9903   | K0D112B00145 | SWITCH                   | 1   | [PAVCSG]              |
| S9904   | K0L1CB000003 | SWITCH                   | 1   | [PAVCSG]              |
| S9905   | K0F111A00541 | SWITCH                   | 1   | [PAVCSG]              |
| ##      | VEK0R03      | CCD UNIT                 |     |                       |
| C3101   | F1J1C106A059 | C.CAPACITOR CH 16V 10U   | 1   |                       |
| C3103   | F1G1H1020008 | C.CAPACITOR CH 50V 1000P | 1   |                       |
| Q3101   | C1AB00003341 | IC                       | 1   | E.S.D.                |
| R3101   | ERJ2GEJ124   | M.RESISTOR CH 1/16W 120K | 1   |                       |
| R3102   | ERJ2GEJ104   | M.RESISTOR CH 1/10W 100K | 1   |                       |
| R3103   | ERJ2GEJ470   | M.RESISTOR CH 1/16W 47   | 1   |                       |
| TH3101  | D4CC11030026 | THERMISTORS              | 1   |                       |

| Ref.No. | Part No.     | Part Name & Description | Pcs | Remarks                              | Ref.No. | Part No.     | Part Name & Description | Pcs | Remarks  |
|---------|--------------|-------------------------|-----|--------------------------------------|---------|--------------|-------------------------|-----|----------|
| 1       | VEP56112B    | MAIN P.C.B.             | 1   | EG,EP,EF,EB (RTL) E.S.D.             | B9      | VHD2206      | SCREW                   | 1   | (-K)     |
| 1       | VEP56112A    | MAIN P.C.B.             | 1   | (EXCEPT EG,EP,EF,EB)<br>(RTL) E.S.D. | B9      | VHD2205      | SCREW                   | 1   | (-W)     |
| 2       | VGK3657      | FRONT GRIP              | 1   | (-K)                                 | B10     | VHD2206      | SCREW                   | 1   | (-K)     |
| 2       | VGK3698      | FRONT GRIP              | 1   | (-W)                                 | B10     | VHD2205      | SCREW                   | 1   | (-W)     |
| 3       | VYK4J22      | FRONT CASE UNIT         | 1   | (-K)                                 | B11     | VHD2206      | SCREW                   | 1   | (-K)     |
| 3       | VYK4J23      | FRONT CASE UNIT         | 1   | (-W)                                 | B11     | VHD2205      | SCREW                   | 1   | (-W)     |
| 4       | VMP9735      | FRONT PLATE             | 1   |                                      | B12     | VHD2206      | SCREW                   | 1   | (-K)     |
| 5       | VYK4F35      | LENS ORNAMENT UNIT      | 1   | (-K)                                 | B12     | VHD2205      | SCREW                   | 1   | (-W)     |
| 5       | VYK4G90      | LENS ORNAMENT UNIT      | 1   | (-W)                                 | B13     | VHD2206      | SCREW                   | 1   | (-K)     |
| 5-1     | VEK0Q61      | AF/MF-ASPECT FPC        | 1   |                                      | B13     | VHD2205      | SCREW                   | 1   | (-W)     |
| 5-2     | VGK3662      | LENS RING FRONT         | 1   | (-K)                                 | B14     | VHD2206      | SCREW                   | 1   | (-K)     |
| 5-2     | VGK3696      | LENS RING FRONT         | 1   | (-W)                                 | B14     | VHD2205      | SCREW                   | 1   | (-W)     |
| 6       | VGQ0A50      | CAPTON TAPE             | 1   |                                      | B15     | VHD2206      | SCREW                   | 1   | (-K)     |
| 9       | VYK4G35      | LCD UNIT                | 1   |                                      | B15     | VHD2205      | SCREW                   | 1   | (-W)     |
| 10      | VYK4G36      | LCD PANEL UNIT          | 1   |                                      | B16     | VHD2208      | SCREW                   | 1   | (-K)     |
| 11      | VYK4G37      | REAR CASE UNIT          | 1   | (-K)                                 | B16     | VHD2207      | SCREW                   | 1   | (-W)     |
| 11      | VYK4G38      | REAR CASE UNIT          | 1   | (-W)                                 | B17     | VHD2208      | SCREW                   | 1   | (-K)     |
| 11-1    | VGK3659      | GRIP PIECE REAR         | 1   | (-K)                                 | B17     | VHD2207      | SCREW                   | 1   | (-W)     |
| 11-1    | VGK3709      | GRIP PIECE REAR         | 1   | (-W)                                 | B18     | VHD2259      | SCREW                   | 1   |          |
| 11-2    | VGL1276      | REAR PANEL LIGHT        | 1   |                                      | B19     | VHD2259      | SCREW                   | 1   |          |
| 11-3    | VGU0G58      | CURSOR BUTTON           | 1   |                                      | B20     | VHD2259      | SCREW                   | 1   |          |
| 12      | VGK3660      | LVF JACK HOLDER         | 1   |                                      | B21     | VHD2259      | SCREW                   | 1   |          |
| 13      | L0AA01A00054 | SPEAKER                 | 1   |                                      | B23     | XQN14+BJ75FN | SCREW                   | 1   |          |
| △ 14    | ML-421S/ZTK  | BUTTON BATTERY          | 1   | [ENERGY] (B9201)                     | B24     | XQN14+BJ75FN | SCREW                   | 1   |          |
| 15      | VEP50067A    | GYRO P.C.B.             | 1   | (RTL) E.S.D.                         | B25     | XQN14+BJ75FN | SCREW                   | 1   |          |
| 16      | VEP51028A    | BATTERY P.C.B.          | 1   | (RTL) E.S.D.                         | B26     | VHD1812      | SCREW                   | 1   |          |
| 17      | VKF4733      | JACK DOOR               | 1   | (-K)                                 | B27     | VHD1812      | SCREW                   | 1   |          |
| 17      | VKF4734      | JACK DOOR               | 1   | (-W)                                 | B28     | VHD1812      | SCREW                   | 1   |          |
| 18      | VMB3962      | BATTERY LOCK SPRING     | 1   |                                      | B52     | VHD2198      | SCREW                   | 1   | [PAVCSG] |
| 19      | VMB4443      | BATTERY OUT SPRING      | 1   |                                      | B53     | XQN14+BJ4FJK | SCREW                   | 1   | [PAVCSG] |
| 20      | VMP9737      | FRAME                   | 1   |                                      | B54     | XQN14+BJ4FJK | SCREW                   | 1   | [PAVCSG] |
| 21      | VMP9738      | BATTERY CASE            | 1   |                                      | B55     | XQN14+BJ4FJK | SCREW                   | 1   | [PAVCSG] |
| 22      | VMS8049      | JACK DOOR SHAFT         | 1   |                                      | B56     | XQN14+BJ4FJK | SCREW                   | 1   | [PAVCSG] |
| 23      | VWJ2191      | MAIN-BATTERY-JOINT FPC  | 1   |                                      |         |              |                         |     |          |
| 24      | VWJ2198      | MAIN-GYRO-JOINT FPC     | 1   |                                      |         |              |                         |     |          |
| 25      | VMC2008      | SHOE SPRING             | 1   |                                      |         |              |                         |     |          |
| 26      | VMP9740      | TORIPOD                 | 1   |                                      |         |              |                         |     |          |
| 27      | VYF3287      | HOTSHOE COVER           | 1   |                                      |         |              |                         |     |          |
| 28      | VGQ0N89      | SPEAKER TAPE            | 1   |                                      |         |              |                         |     |          |
| 29      | VGQ0M00      | BATTERY LOCK KNOB       | 1   |                                      |         |              |                         |     |          |
| 50      | K0RC01100005 | DIAL UNIT               | 1   | [PAVCSG]                             |         |              |                         |     |          |
| 51      | VEK0Q99      | HOT SHOE UNIT           | 1   | [PAVCSG]                             |         |              |                         |     |          |
| 52      | VEP58128A    | FLASH P.C.B.            | 1   | (RTL) [PAVCSG] E.S.D.                |         |              |                         |     |          |
| 53      | VEP59088A    | TOP P.C.B.              | 1   | (RTL) [PAVCSG] E.S.D.                |         |              |                         |     |          |
| 54      | VEP59089A    | LVF P.C.B.              | 1   | (RTL) [PAVCSG] E.S.D.                |         |              |                         |     |          |
| 55      | VYK4J20      | TOP CASE UNIT           | 1   | (-K) [PAVCSG]                        |         |              |                         |     |          |
| 55      | VYK4J21      | TOP CASE UNIT           | 1   | (-W) [PAVCSG]                        |         |              |                         |     |          |
| 56      | VGL1290      | AF PANEL LIGHT          | 1   | [PAVCSG]                             |         |              |                         |     |          |
| 57      | VGQ0H34-A    | COUPLING PLATE          | 1   | [PAVCSG]                             |         |              |                         |     |          |
| 58      | VGQ0Q88      | DPR SHEET               | 1   | [PAVCSG]                             |         |              |                         |     |          |
| 59      | VKH0457      | STRAP HOLDER (L)        | 1   | [PAVCSG]                             |         |              |                         |     |          |
| 60      | VKH0458      | STRAP HOLDER (R)        | 1   | [PAVCSG]                             |         |              |                         |     |          |
| 61      | VMP9739      | SHIELD PLATE            | 1   | [PAVCSG]                             |         |              |                         |     |          |
| 62      | VMP9742      | TOP PLATE               | 1   | [PAVCSG]                             |         |              |                         |     |          |
| 63      | VWJ2192      | MAIN-LVF JOINT FPC      | 1   | [PAVCSG]                             |         |              |                         |     |          |
| 64      | VYK4K22      | FLASH UNIT              | 1   | (-K) [PAVCSG]                        |         |              |                         |     |          |
| 64      | VYK4K23      | FLASH UNIT              | 1   | (-W) [PAVCSG]                        |         |              |                         |     |          |
| 65      | VYF3364      | BATTERY DOOR UNIT       | 1   | (-K) [PAVCSG]                        |         |              |                         |     |          |
| 65      | VYF3365      | BATTERY DOOR UNIT       | 1   | (-W) [PAVCSG]                        |         |              |                         |     |          |
| 65-1    | VMB4332      | BATTERY DOOR SPRING     | 1   | [PAVCSG]                             |         |              |                         |     |          |
| 65-2    | VMS8040      | BATTERY DOOR SHAFT      | 1   | [PAVCSG]                             |         |              |                         |     |          |
| 66      | VGQ0N71      | FL PCB COVER            | 1   | [PAVCSG]                             |         |              |                         |     |          |
| 67      | VGQ0N77      | FL TAPE (A)             | 1   | [PAVCSG]                             |         |              |                         |     |          |
| 68      | VWJ2190      | MAIN-FLASH JOINT FPC    | 1   | [PAVCSG]                             |         |              |                         |     |          |
| △ 69    | F2A2F9000005 | E.CAPACITOR             | 1   | [PAVCSG] (C8003)                     |         |              |                         |     |          |
| 70      | VMB4393      | EARTH SPRING            | 1   | [PAVCSG]                             |         |              |                         |     |          |
| B1      | RHD14153     | SCREW                   | 1   |                                      |         |              |                         |     |          |
| B2      | RHD14153     | SCREW                   | 1   |                                      |         |              |                         |     |          |
| B3      | RHD14153     | SCREW                   | 1   |                                      |         |              |                         |     |          |
| B4      | RHD14153     | SCREW                   | 1   |                                      |         |              |                         |     |          |
| B5      | VHD1803      | SCREW                   | 1   |                                      |         |              |                         |     |          |
| B6      | VHD2207      | SCREW                   | 1   |                                      |         |              |                         |     |          |
| B7      | VHD1678      | SCREW                   | 1   |                                      |         |              |                         |     |          |
| B8      | VHD1678      | SCREW                   | 1   |                                      |         |              |                         |     |          |





| Ref.No. | Part No. | Part Name & Description | Pcs               | Remarks  |
|---------|----------|-------------------------|-------------------|--|
|         | 400      | VPF1137                 | CAMERA BAG        | 1 (EXCEPT P,PC,PU)                                 |
| △       | 402      | DE-A82AA                | BATTERY CHARGER   | 1 EG,EP,EF,EB,EE,GN                                |
| △       | 402      | DE-A82BA                | BATTERY CHARGER   | 1 GC,GK,GD   |
| △       | 402      | DE-A82DA                | BATTERY CHARGER   | 1 SG   |
| △       | 402      | DE-A82CA                | BATTERY CHARGER   | 1 GT   |
| △       | 403      | ----                    | BATTERY           | 1 (EXCEPT P,PC,PU)                                 |
|         | 404      | K1HA08AD0002            | USB CABLE W/PLUG  | 1 (EXCEPT P,PC,PU)                                 |
|         | 405      | K1HA08CD0028            | AV CABLE W/PLUG   | 1 (EXCEPT P,PC,PU)                                 |
|         | 406      | VFC4324                 | SHOULDER STRAP    | 1 (EXCEPT P,PC,PU)                                 |
|         | 407      | VFF0665-S               | CD-ROM            | 1 GK   |
|         |          |                         |                   | See "Notes"  |
|         | 407      | VFF0664-S               | CD-ROM            | 1 EG,EP,EF,EB,EE,GC,SG,<br>GT,GN,GD                |
|         |          |                         |                   | See "Notes"  |
|         | 408      | VPK4539                 | PACKING CASE      | 1 EGK,EPK,EFK,EBK,EEK,GCK,<br>SGK,GNK              |
|         | 408      | VPK4547                 | PACKING CASE      | 1 GCW,GNW  |
|         | 408      | VPK4540                 | PACKING CASE      | 1 GKK  |
|         | 408      | VPK4548                 | PACKING CASE      | 1 GKW  |
|         | 408      | VPK4539                 | PACKING CASE      | 1 GTK,GDK  |
|         |          |                         |                   | Please use the attached<br>Ref No.410 (NTSC LABEL) |
|         | 408      | VPK4547                 | PACKING CASE      | 1 GTW,GDW  |
|         |          |                         |                   | Please use the attached<br>Ref No.410 (NTSC LABEL) |
|         | 408      | VPK4540                 | PACKING CASE      | 1 GKK  |
|         | 408      | VPK4548                 | PACKING CASE      | 1 GKW  |
|         | 409      | VPN7078                 | CUSION            | 1 (EXCEPT P,PC,PU)                                 |
|         | 410      | VQL1222                 | NTSC LABEL        | 1 GT,GD  |
|         | 411      | VPF1230                 | BAG, POLYETHYLENE | 1 (EXCEPT P,PC,PU)                                 |
| △       | 412      | VFF0672                 | CD-ROM            | 1 EG,EP,EF,EB                                      |
|         |          |                         |                   | (INSTRUCTION BOOK)                                 |
| △       | 412      | VFF0673                 | CD-ROM            | 1 EE,SG  |
|         |          |                         |                   | (INSTRUCTION BOOK)                                 |
| △       | 412      | VFF0674                 | CD-ROM            | 1 GC,GN  |
|         |          |                         |                   | (INSTRUCTION BOOK)                                 |
| △       | 412      | VFF0675                 | CD-ROM            | 1 GT,GD  |
|         |          |                         |                   | (INSTRUCTION BOOK)                                 |
| △       | 412      | VFF0676                 | CD-ROM            | 1 GK   |
|         |          |                         |                   | (INSTRUCTION BOOK)                                 |
| △       | 413      | VQT2W86                 | SIMPLIFIED O/I    | 1 EG   |
|         |          |                         |                   | (GERMAN/FRENCH)                                    |
| △       | 413      | VQT2W87                 | SIMPLIFIED O/I    | 1 EG   |
|         |          |                         |                   | (ITALIAN/DUTCH)                                    |
| △       | 413      | VQT2W88                 | SIMPLIFIED O/I    | 1 EG   |
|         |          |                         |                   | (SPANISH/PORTUGUESE)                               |
| △       | 413      | VQT2W89                 | SIMPLIFIED O/I    | 1 EG   |
|         |          |                         |                   | (TURKISH)  |
| △       | 413      | VQT2W90                 | SIMPLIFIED O/I    | 1 EP   |
|         |          |                         |                   | (SWEDISH/DANISH)                                   |
| △       | 413      | VQT2W91                 | SIMPLIFIED O/I    | 1 EP   |
|         |          |                         |                   | (POLISH/CZECH)                                     |
| △       | 413      | VQT2W92                 | SIMPLIFIED O/I    | 1 EP   |
|         |          |                         |                   | (HUNGARIAN/FINNISH)                                |
| △       | 413      | VQT2W93                 | SIMPLIFIED O/I    | 1 EF   |
|         |          |                         |                   | (FRENCH)   |
| △       | 413      | VQT2W94                 | SIMPLIFIED O/I    | 1 EB   |
|         |          |                         |                   | (ENGLISH)  |
| △       | 413      | VQT2W95                 | SIMPLIFIED O/I    | 1 EE   |
|         |          |                         |                   | (RUSSIAN/UKRAINIAN)                                |
| △       | 413      | VQT2W96                 | SIMPLIFIED O/I    | 1 GC,SG  |
|         |          |                         |                   | (ENGLISH/<br>CHINESE(TRADITIONAL))                 |
| △       | 413      | VQT2W97                 | SIMPLIFIED O/I    | 1 GC   |
|         |          |                         |                   | (ARABIC/PERSIAN)                                   |
| △       | 413      | VQT2W98                 | SIMPLIFIED O/I    | 1 GT   |
|         |          |                         |                   | (CHINESE(TRADITIONAL))                             |
| △       | 413      | VQT2W99                 | SIMPLIFIED O/I    | 1 GK   |
|         |          |                         |                   | (CHINESE(SIMPLIFIED))                              |
| △       | 413      | VQT2X00                 | SIMPLIFIED O/I    | 1 GN   |
|         |          |                         |                   | (ENGLISH)  |
| △       | 413      | VQT2X01                 | INSTRUCTION BOOK  | 1 GD   |
|         |          |                         |                   | (KOREAN)   |

| Ref.No. | Part No. | Part Name & Description | Pcs                     | Remarks  |
|---------|----------|-------------------------|-------------------------|--|
|         | 414      | VQC7825                 | O/I SOFTWARE            | 1 EG   |
|         |          |                         |                         | (GERMAN/FRENCH/ITALIAN/<br>DUTCH/SPANISH/PORTUGUESE/<br>TURKISH) |
|         | 414      | VQC7826                 | O/I SOFTWARE            | 1 EP   |
|         |          |                         |                         | (FINNISH/SWEDISH/DANISH/<br>POLISH/CZECH/HUNGARIAN)              |
|         | 414      | VQC7827                 | O/I SOFTWARE            | 1 EF   |
|         |          |                         |                         | (FRENCH)   |
|         | 414      | VQC7828                 | O/I SOFTWARE            | 1 EB,GN  |
|         |          |                         |                         | (ENGLISH)  |
|         | 414      | VQC7829                 | O/I SOFTWARE            | 1 EE   |
|         |          |                         |                         | (RUSSIAN/UKRAINIAN)  |
|         | 414      | VQC7830                 | O/I SOFTWARE            | 1 GC,SG  |
|         |          |                         |                         | (ENGLISH/<br>CHINESE(TRADITIONAL)/<br>ARABIC/PERSIAN)            |
|         | 414      | VQC7831                 | O/I SOFTWARE            | 1 GT   |
|         |          |                         |                         | (CHINESE(TRADITIONAL))   |
|         | 414      | VQC7832                 | O/I SOFTWARE            | 1 GK   |
|         |          |                         |                         | (CHINESE(SIMPLIFIED))  |
|         | 414      | VQC7833                 | O/I SOFTWARE            | 1 GD   |
|         |          |                         |                         | (KOREAN)   |
|         | 415      | VGQ0N97                 | BATTERY PROTECTION CASE | 1 (EXCEPT P,PC,PU)   |
|         | 416      | VFC4366                 | STRING                  | 1 (EXCEPT P,PC,PU)   |
|         | 417      | VYF3361                 | LENS CAP UNIT           | 1 (-K)   |
|         | 417      | VYF3376                 | LENS CAP UNIT           | 1 (-W)   |
| △       | 419      | K2CT39A00002            | AC CORD W/PLUG          | 1 EB,GC  |
| △       | 420      | K2CQ29A00002            | AC CORD W/PLUG          | 1 EG,EP,EF,EE,GC   |
| △       | 420      | K2CR29A00001            | AC CORD W/PLUG          | 1 GD   |
| △       | 421      | K2CJ29A00002            | AC CORD W/PLUG          | 1 GN   |
| △       | 422      | K2CA29A00023            | AC CORD W/PLUG          | 1 SG   |
| △       | 422      | K2CA29A00021            | AC CORD W/PLUG          | 1 GT   |
| △       | 422      | K2CA29Y00070            | AC CORD W/PLUG          | 1 GK   |
|         | 430      | VQL2C68-1               | OPERATING LABEL         | 1 GT   |

# S7. Exploded View

## S7.1. Frame and Casing Section

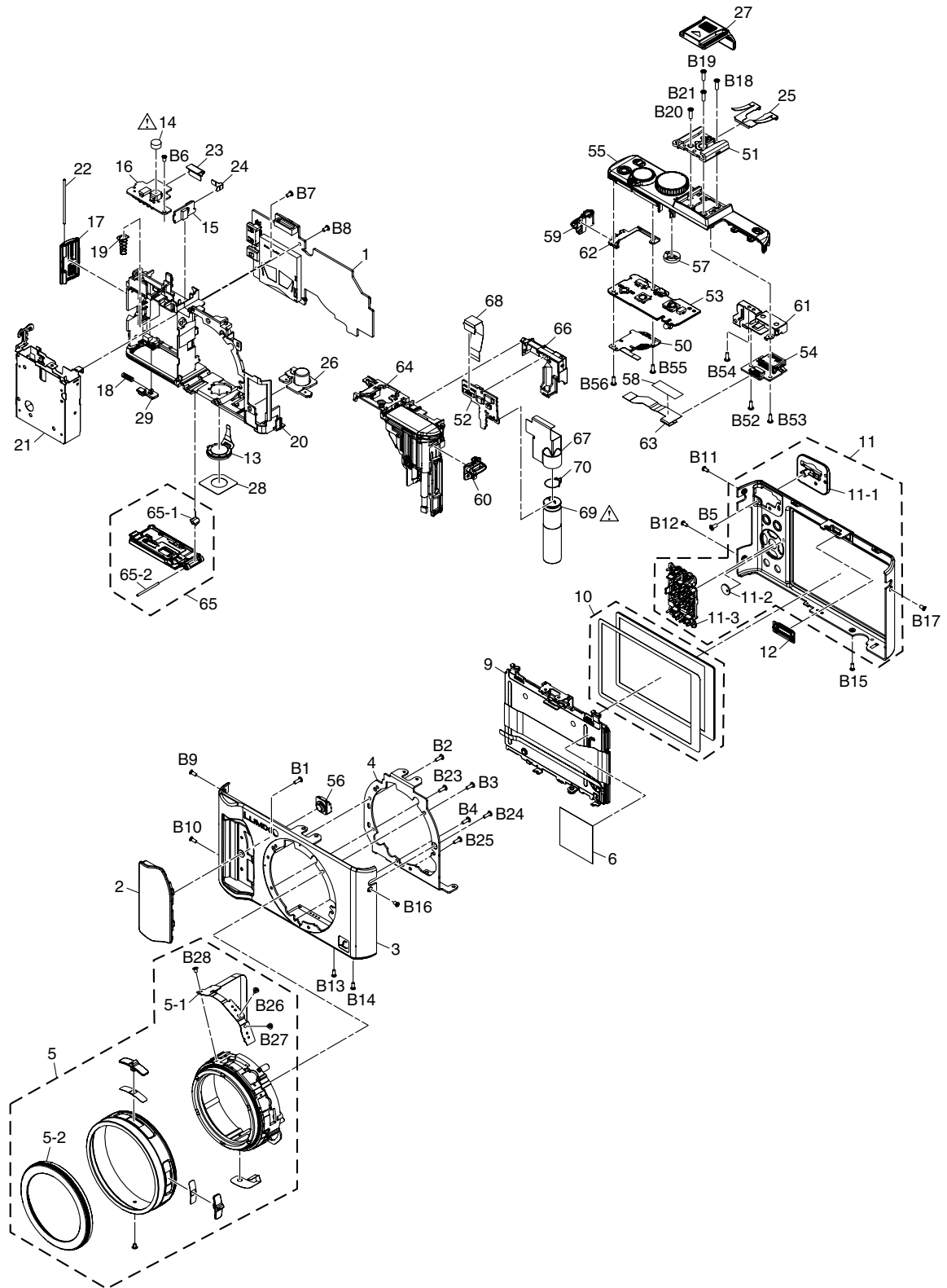

## S7.2. Camera Lens Section

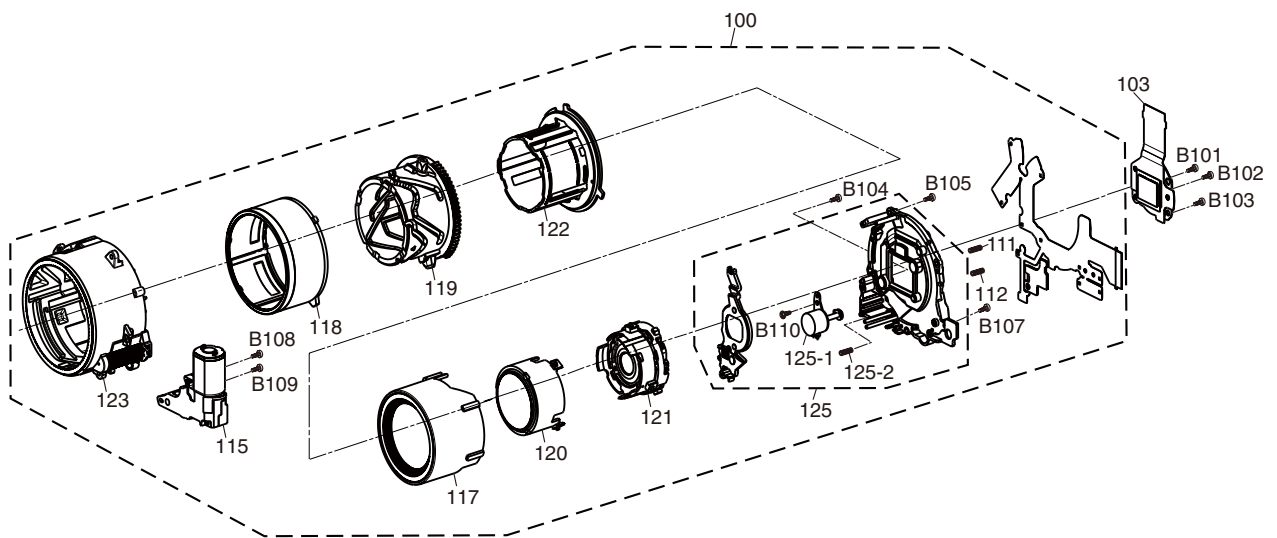

### S7.3. Packing Parts and Accessories Section (1)

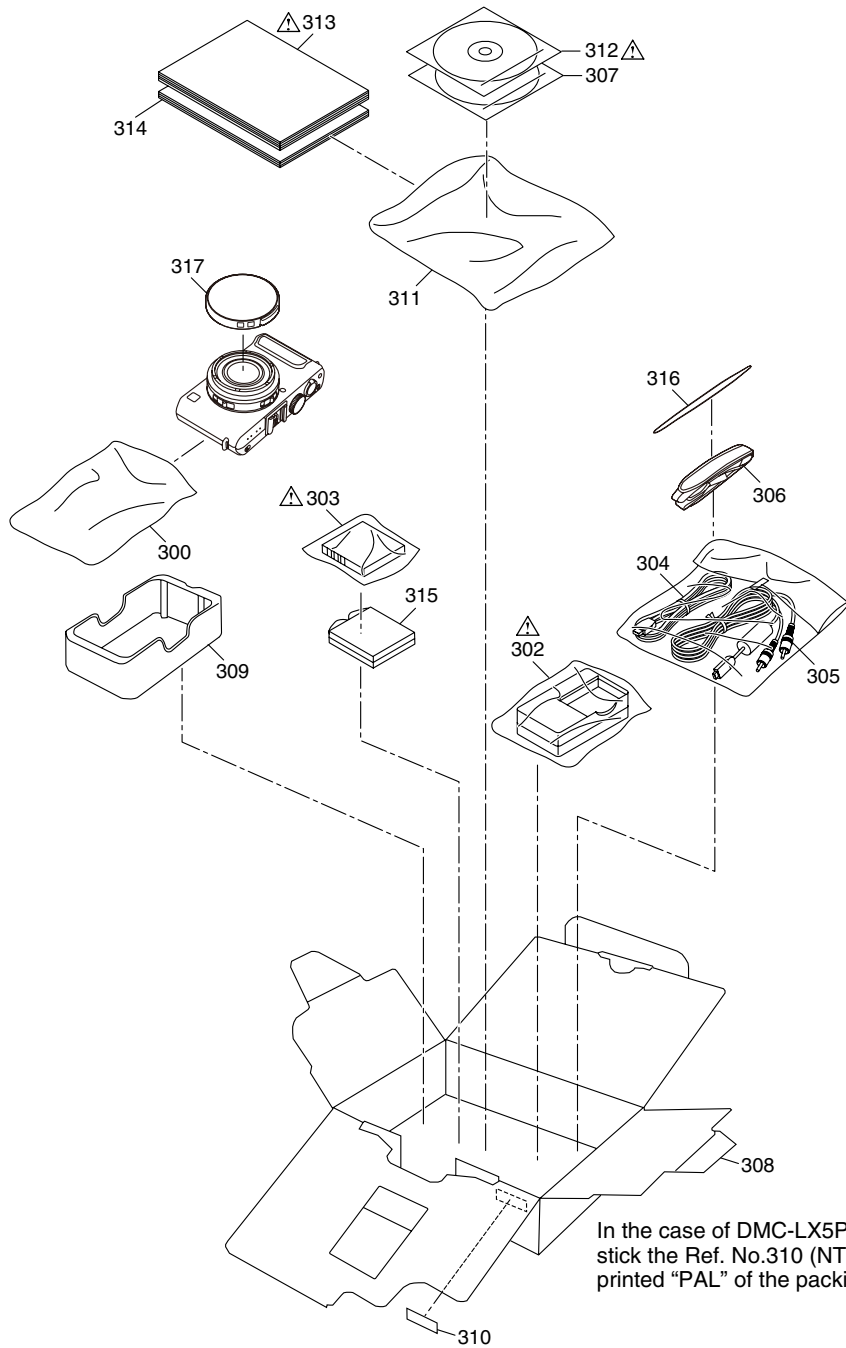

## S7.4. Packing Parts and Accessories Section (2)

