

# Service Manual

Digital Camera

LUMIX

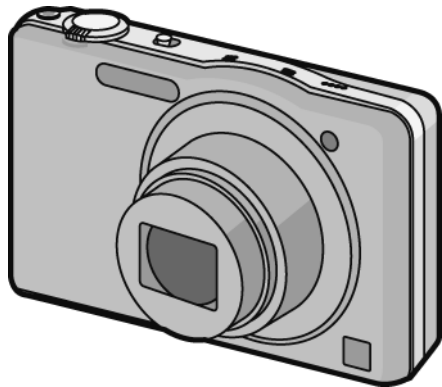

Model No. **DMC-SZ7P**  
**DMC-SZ7PC**  
**DMC-SZ7PU**  
**DMC-SZ7EB**  
**DMC-SZ7EE**  
**DMC-SZ7EF**  
**DMC-SZ7EG**  
**DMC-SZ7EP**  
**DMC-SZ7GA**  
**DMC-SZ7GC**  
**DMC-SZ7GF**  
**DMC-SZ7GK**  
**DMC-SZ7GN**

Colour

(K).....Black Type  
(P).....Pink Type (only PU/GA/GC/GF/GK/GN)  
(T).....Brown Type (except P/PC/PU/EP/GC/GN)  
(W).....White Type (except P/PU/EE/EF/EP/GC)

## WARNING

This service information is designed for experienced repair technicians only and is not designed for use by the general public. It does not contain warnings or cautions to advise non-technical individuals of potential dangers in attempting to service a product. Products powered by electricity should be serviced or repaired only by experienced professional technicians. Any attempt to service or repair the product or products dealt with in this service information by anyone else could result in serious injury or death.

**Panasonic**<sup>®</sup>

© Panasonic Corporation 2012 Unauthorized copying and distribution is a violation of law.

# TABLE OF CONTENTS

|   | PAGE      | PAGE |
|---|-----------|------|
| <b>1 Safety Precautions</b> .....   | <b>3</b>  |      |
| 1.1. General Guidelines .....   | 3         |      |
| 1.2. Leakage Current Cold Check .....   | 3         |      |
| 1.3. Leakage Current Hot Check (See Figure 1.) .....  | 3         |      |
| 1.4. How to Discharge the E.Capacitor on Flash<br>Top P.C.B. ....                                     | 4         |      |
| <b>2 Warning</b> .....  | <b>5</b>  |      |
| 2.1. Prevention of Electrostatic Discharge (ESD)<br>to Electrostatically Sensitive (ES) Devices ..... | 5         |      |
| 2.2. How to Recycle the Lithium Ion Battery (U.S.<br>Only) .....                                      | 5         |      |
| 2.3. How to Replace the Lithium Battery .....   | 6         |      |
| <b>3 Service Navigation</b> .....   | <b>7</b>  |      |
| 3.1. Introduction .....   | 7         |      |
| 3.2. Important Notice .....   | 7         |      |
| 3.3. General Description About Lead Free Solder<br>(PbF) .....  | 7         |      |
| 3.4. Important Notice 1:(Other than U.S.A. and<br>Canadian Market) .....                              | 7         |      |
| 3.5. How to Define the Model Suffix (NTSC or PAL<br>model) .....                                      | 8         |      |
| <b>4 Specifications</b> .....   | <b>12</b> |      |
| <b>5 Location of Controls and Components</b> .....  | <b>13</b> |      |
| <b>6 Service Mode</b> .....   | <b>15</b> |      |
| 6.1. Error Code Memory Function .....   | 15        |      |
| <b>7 Service Fixture &amp; Tools</b> .....  | <b>18</b> |      |
| 7.1. Service Fixture and Tools .....  | 18        |      |
| 7.2. When Replacing the Main P.C.B. ....  | 19        |      |
| 7.3. Service Position .....   | 19        |      |
| <b>8 Disassembly and Assembly Instructions</b> .....  | <b>20</b> |      |
| 8.1. Disassembly Flow Chart .....   | 20        |      |
| 8.2. P.C.B. Location .....  | 20        |      |
| 8.3. Disassembly Procedure .....  | 20        |      |
| 8.4. Lens Disassembly Procedure .....   | 26        |      |
| 8.5. Removal of the Focus Motor .....   | 28        |      |
| 8.6. The Application of Grease Method .....   | 28        |      |
| 8.7. Removal of the MOS FPC Unit .....  | 29        |      |
| <b>9 Measurements and Adjustments</b> .....   | <b>30</b> |      |
| 9.1. Introduction .....   | 30        |      |
| 9.2. Before Disassembling the unit .....  | 30        |      |
| 9.3. Details of Electrical Adjustment .....   | 32        |      |
| 9.4. After Adjustment .....   | 37        |      |
| <b>10 Maintenance</b> .....   | <b>38</b> |      |
| 10.1. Cleaning Lens and LCD Panel .....   | 38        |      |
| <b>11 Block Diagram</b> .....   | <b>39</b> |      |
| 11.1. Overall Block Diagram .....   | 39        |      |
| 11.2. System Control Block Diagram .....  | 40        |      |
| 11.3. Video/Audio Process Block Diagram .....   | 41        |      |
| 11.4. Lens Drive Block Diagram .....  | 42        |      |
| 11.5. Power Block Diagram .....   | 43        |      |
| <b>12 Wiring Connection Diagram</b> .....   | <b>44</b> |      |
| 12.1. Interconnection Diagram .....   | 44        |      |

# 1 Safety Precautions

## 1.1. General Guidelines

### 1. IMPORTANT SAFETY NOTICE

There are special components used in this equipment which are important for safety. These parts are marked by

 in the Schematic Diagrams, Circuit Board Layout, Exploded Views and Replacement Parts List. It is essential that these critical parts should be replaced with manufacturer's specified parts to prevent X-RADIATION, shock, fire, or other hazards. Do not modify the original design without permission of manufacturer.

2. An Isolation Transformer should always be used during the servicing of AC Adaptor whose chassis is not isolated from the AC power line. Use a transformer of adequate power rating as this protects the technician from accidents resulting in personal injury from electrical shocks. It will also protect AC Adaptor from being damaged by accidental shorting that may occur during servicing.
3. When servicing, observe the original lead dress. If a short circuit is found, replace all parts which have been overheated or damaged by the short circuit.
4. After servicing, see to it that all the protective devices such as insulation barriers, insulation papers shields are properly installed.
5. After servicing, make the following leakage current checks to prevent the customer from being exposed to shock hazards.

## 1.2. Leakage Current Cold Check

1. Unplug the AC cord and connect a jumper between the two prongs on the plug.
2. Measure the resistance value, with an ohmmeter, between the jumpered AC plug and each exposed metallic cabinet part on the equipment such as screwheads, connectors, control shafts, etc. When the exposed metallic part has a return path to the chassis, the reading should be between  $1\text{ M}\Omega$  and  $5.2\text{ M}\Omega$ . When the exposed metal does not have a return path to the chassis, the reading must be infinity.

## 1.3. Leakage Current Hot Check (See Figure 1.)

1. Plug the AC cord directly into the AC outlet. Do not use an isolation transformer for this check.
2. Connect a  $1.5\text{ k}\Omega$ ,  $10\text{ W}$  resistor, in parallel with a  $0.15\text{ }\mu\text{F}$  capacitor, between each exposed metallic part on the set and a good earth ground, as shown in Figure 1.
3. Use an AC voltmeter, with  $1\text{ k}\Omega/\text{V}$  or more sensitivity, to measure the potential across the resistor.
4. Check each exposed metallic part, and measure the voltage at each point.
5. Reverse the AC plug in the AC outlet and repeat each of the above measurements.
6. The potential at any point should not exceed  $0.75\text{ V RMS}$ . A leakage current tester (Simpson Model 229 or equivalent) may be used to make the hot checks, leakage current must not exceed  $1/2\text{ mA}$ . In case a measurement is outside of the limits specified, there is a possibility of a shock hazard, and the equipment should be repaired and rechecked before it is returned to the customer.

Hot-Check Circuit

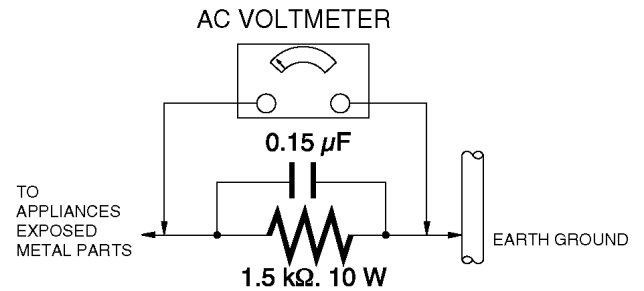

Figure. 1

## 1.4. How to Discharge the E.Capacitor on Flash Top P.C.B.

### CAUTION:

1. Be sure to discharge the E.capacitor on FLASH TOP P.C.B..
2. Be careful of the high voltage circuit on FLASH TOP P.C.B. when servicing.

### [Discharging Procedure]

1. Refer to the disassemble procedure and remove the necessary parts/unit.
2. Install the insulation tube onto the lead part of resistor (ERG5SJ102:1k $\Omega$  /5W).  
(An equivalent type of resistor may be used.)
3. Place a resistor between both terminals of E.capacitor on the FLASH TOP P.C.B. for approx. 5 seconds.
4. After discharging, confirm that the E.capacitor voltage is lower than 10V by using a voltmeter.

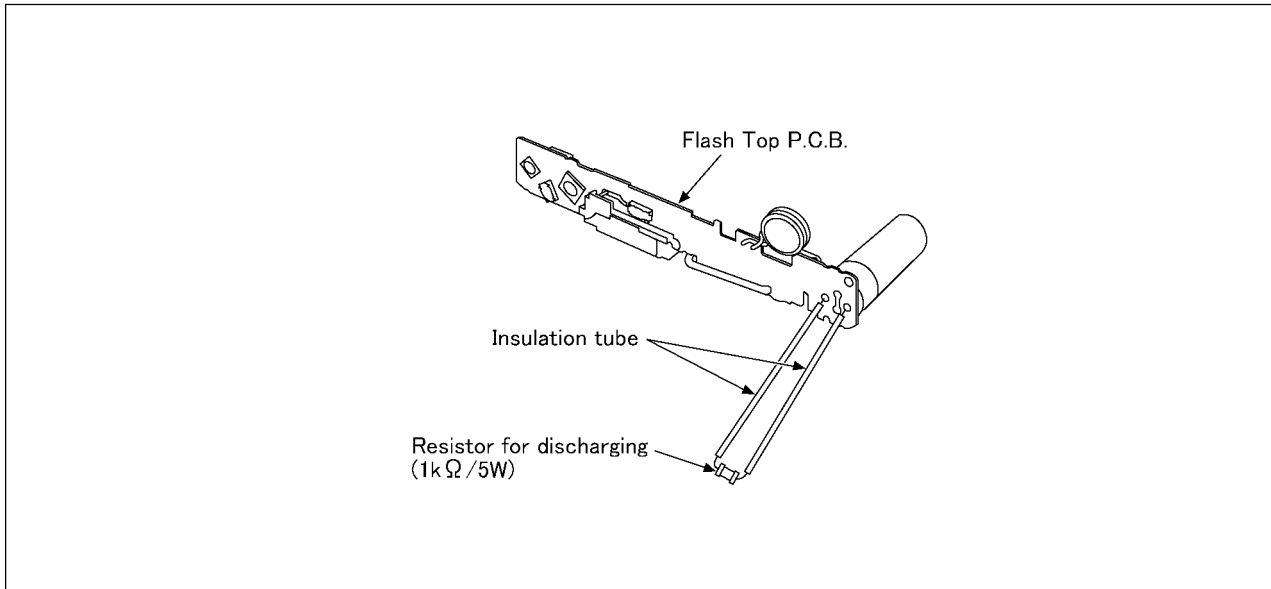

Fig. F1

## 2 Warning

### 2.1. Prevention of Electrostatic Discharge (ESD) to Electrostatically Sensitive (ES) Devices

Some semiconductor (solid state) devices can be damaged easily by static electricity. Such components commonly are called Electrostatically Sensitive (ES) Devices.

Examples of typical ES devices are IC (integrated circuits) and some field-effect transistors and semiconductor "chip" components.

The following techniques should be used to help reduce the incidence of component damage caused by electrostatic discharge (ESD).

1. Immediately before handling any semiconductor component or semiconductor-equipped assembly, drain off any ESD on your body by touching a known earth ground. Alternatively, obtain and wear a commercially available discharging ESD wrist strap, which should be removed for potential shock reasons prior to applying power to the unit under test.
2. After removing an electrical assembly equipped with ES devices, place the assembly on a conductive surface such as aluminum foil, to prevent electrostatic charge buildup or exposure of the assembly.
3. Use only a grounded-tip soldering iron to solder or unsolder ES devices.
4. Use only an antistatic solder removal device. Some solder removal devices not classified as "antistatic (ESD protected)" can generate electrical charge sufficient to damage ES devices.
5. Do not use freon-propelled chemicals. These can generate electrical charges sufficient to damage ES devices.
6. Do not remove a replacement ES device from its protective package until immediately before you are ready to install it. (Most replacement ES devices are packaged with leads electrically shorted together by conductive foam, aluminum foil or comparable conductive material).
7. Immediately before removing the protective material from the leads of a replacement ES device, touch the protective material to the chassis or circuit assembly into which the device will be installed.

**CAUTION :**

Be sure no power is applied to the chassis or circuit, and observe all other safety precautions.

8. Minimize bodily motions when handling unpackaged replacement ES devices. (Otherwise harmless motion such as the brushing together of your clothes fabric or the lifting of your foot from a carpeted floor can generate static electricity (ESD) sufficient to damage an ES device).

### 2.2. How to Recycle the Lithium Ion Battery (U.S. Only)

**ENGLISH**



A lithium ion battery that is recyclable powers the product you have purchased. Please call 1-800-8-BATTERY for information on how to recycle this battery.

**FRANÇAIS**



L'appareil que vous vous êtes procuré est alimenté par une batterie au lithium-ion recyclable. Pour des renseignements sur le recyclage de la batterie, veuillez composer le 1-800-8-BATTERY.

## 2.3. How to Replace the Lithium Battery

### 2.3.1. Replacement Procedure

1. Remove the SUB OPERATION P.C.B.. (Refer to Disassembly Procedures.)
2. Unsolder the each soldering point of electric lead terminal for Lithium battery (Ref. No. "B9501" at component side of SUB OPERATION P.C.B.) and remove the Lithium battery together with electric lead terminal. Then replace it into new one.

**NOTE:**

The Type No. ML421 includes electric lead terminals.

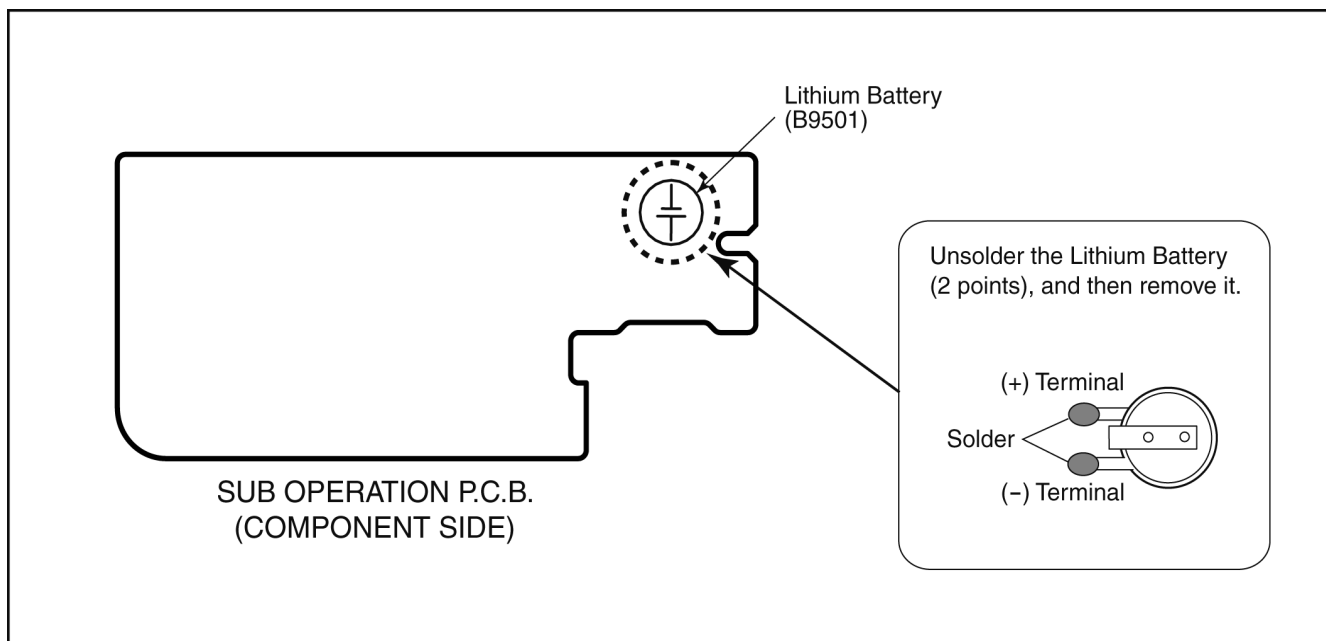

**NOTE:**

This Lithium battery is a critical component.

(Type No.: ML421 **Manufactured by Energy Company, Panasonic Corporation.**)

It must never be subjected to excessive heat or discharge.

It must therefore only be fitted in requirement designed specifically for its use.

Replacement batteries must be of same type and manufacture.

They must be fitted in the same manner and location as the original battery, with the correct polarity contacts observed.

Do not attempt to re-charge the old battery or re-use it for any other purpose.

It should be disposed of in waste products destined for burial rather than incineration.

**(For English)**

**CAUTION**

- Danger of explosion if battery is incorrectly replaced. Replace only with the type recommended by the manufacturer.
- When disposing the batteries, please contact your local authorities or dealer and ask for the correct method of disposal.

**(For German)**

**ACHTUNG**

- Explosionsgefahr bei falschem Anbringen der Batterie. Ersetzen Sie die Batterie nur durch den vom Hersteller empfohlenen Typ.
- Wenden Sie sich zur Entsorgung der Batterien an die lokalen Behörden oder erfragen Sie die richtige Vorgehensweise zur Entsorgung.

**(For French)**

**MISE EN GARDE**

- Il y a un danger d'explosion si la batterie n'est pas correctement remplacée. Remplacez-la uniquement par le type recommandé par le fabricant.
- Pour vous débarrasser des batteries, veuillez contacter les autorités locales ou votre revendeur afin de connaître la procédure d'élimination à suivre.

**NOTE:**

Above caution is applicable for a battery pack which is for DMC-SZ7 series, as well.

# 3 Service Navigation

## 3.1. Introduction

This service manual contains technical information, which allow service personnel's to understand and service this model. Please place orders using the parts list and not the drawing reference numbers. If the circuit is changed or modified, the information will be followed by service manual to be controlled with original service manual.

## 3.2. Important Notice

### 3.2.1. MOS FPC UNIT:

- The image sensor (MOS FPC) unit which are connected to the lens unit with 3 screws. These screws are locked with the screw locking glue, after performing the Optical tilt adjustment. During servicing, if one of MOS FPC fixing screws are loosened, the Optical tilt adjustment must be performed. About the Optical tilt adjustment, refer to the "9.3.2 Adjustment Specifications" for details.

### 3.2.2. About Flexible Cable and Connector

Do not touch carelessly so that the foreign body should not adhere to the terminal part of flexible cable and connector. Wipe off with a clean cloth and the cotton bud, etc. when the terminal part is dirty.

## 3.3. General Description About Lead Free Solder (PbF)

The lead free solder has been used in the mounting process of all electrical components on the printed circuit boards used for this equipment in considering the globally environmental conservation.

The normal solder is the alloy of tin (Sn) and lead (Pb). On the other hand, the lead free solder is the alloy mainly consists of tin (Sn), silver (Ag) and Copper (Cu), and the melting point of the lead free solder is higher approx.30°C (86°F) more than that of the normal solder.

### Distinction of P.C.B. Lead Free Solder being used

|  |            |
|--|------------|
| The letter of "PbF" is printed either foil side or components side on the P.C.B. using the lead free solder.(See right figure) | <b>PbF</b> |
|--|------------|

### Service caution for repair work using Lead Free Solder (PbF)

- The lead free solder has to be used when repairing the equipment for which the lead free solder is used. (Definition: The letter of "PbF" is printed on the P.C.B. using the lead free solder.)
- To put lead free solder, it should be well molten and mixed with the original lead free solder.
- Remove the remaining lead free solder on the P.C.B. cleanly for soldering of the new IC.
- Since the melting point of the lead free solder is higher than that of the normal lead solder, it takes the longer time to melt the lead free solder.
- Use the soldering iron (more than 70W) equipped with the temperature control after setting the temperature at 350±30°C (662±86°F).

### Recommended Lead Free Solder (Service Parts Route.)

- The following 3 types of lead free solder are available through the service parts route.
  - RFKZ03D01KS-----(0.3mm 100g Reel)
  - RFKZ06D01KS-----(0.6mm 100g Reel)
  - RFKZ10D01KS-----(1.0mm 100g Reel)

### Note

\* Ingredient: tin (Sn) 96.5%, silver (Ag) 3.0%, Copper (Cu) 0.5%, Cobalt (Co) / Germanium (Ge) 0.1 to 0.3%

## 3.4. Important Notice 1:(Other than U.S.A. and Canadian Market)

1. The service manual does not contain the following information because of issues servicing to component level without necessary equipment/facilities.
  - a. Schematic diagram, Block Diagram and P.C.B. layout of MAIN P.C.B. and SUB OPERATION P.C.B..
  - b. Parts list for individual parts for MAIN P.C.B. and SUB OPERATION P.C.B..
 When a part replacement is required for repairing MAIN P.C.B. and/or SUB OPERATION P.C.B., replace as an assembled parts. (MAIN P.C.B./SUB OPERATION P.C.B.)
2. The following category is/are recycle module part. please send it/them to Central Repair Center.
  - MAIN P.C.B. (VEP56148A : P/PC/PU/EE/GC/GF/GA/GK/GN)
  - MAIN P.C.B. (VEP56148B : EG/EP/EF/EB)
  - SUB OPERATION P.C.B. (VEP59108A): Excluding replacement of Lithium Battery

### 3.5. How to Define the Model Suffix (NTSC or PAL model)







There are seven kinds of DMC-SZ7, regardless of the colours.

- a) DMC-SZ7 (Japan domestic model)
- b) DMC-SZ7P/PC
- c) DMC-SZ7EB/EF/EG/EP
- d) DMC-SZ7EE
- e) DMC-SZ7GK
- f) DMC-SZ7GN
- g) DMC-SZ7PU/GA/GC/GF

What is the difference is that the "INITIAL SETTINGS" data which is stored in Flash-ROM mounted on MAIN P.C.B..

#### 3.5.1. Defining methods:

To define the model suffix to be serviced, refer to the nameplate which is putted on the bottom side of the Unit.

|  |
|--|
| <p><b>a) DMC-SZ7 (Japan domestic model)</b><br/>The nameplate for this model shows the following Safety registration mark.</p>  |
| <p><b>b) DMC-SZ7P/PC</b><br/>The nameplate for these models show the following Safety registration mark.</p>                    |
| <p><b>c) DMC-SZ7EB/EF/EG/EP</b><br/>The nameplate for these models show the following Safety registration mark.</p>            |
| <p><b>d) DMC-SZ7EE</b><br/>The nameplate for this model shows the following Safety registration mark.</p>                     |
| <p><b>e) DMC-SZ7GK</b><br/>The nameplate for this model shows the following Safety registration mark.</p>                     |
| <p><b>f) DMC-SZ7GN</b><br/>The nameplate for this model shows the following Safety registration mark.</p>                     |
| <p><b>g) DMC-SZ7PU/GA/GC/GF</b><br/>The nameplate for these models do not show any above Safety registration mark.</p>   |

**NOTE:**

After replacing the MAIN P.C.B., be sure to achieve adjustment.

The service software is available at "TSN Website". To download, click on "Support Information from NWBG/VDBG-AVC".

### 3.5.2. INITIAL SETTINGS:

After replacing the MAIN P.C.B., make sure to perform the initial settings after achieving the adjustment by ordering the following procedure in accordance with model suffix of the unit.

#### 1. IMPORTANT NOTICE:

Before proceeding Initial settings, make sure to read the following CAUTIONS.

### CAUTION 1:(INITIAL SETTINGS)

---AFTER REPLACING THE MAIN P.C.B. and/or FLASH-ROM ---

[Except "EG, EP, EF and EB" models : (VEP56148A is used as a Main P.C.B.)]

\*.The model suffix can be chosen **JUST ONE TIME.**

(Effective model suffix : " P/PC/PU/EE/GC/GF/GA/GK/GN/JAPAN domestic model ")

\*.Once one of the model suffix has been chosen, the model suffix lists will not be displayed, thus, it can not be changed.

[Only for "EG, EP, EF and EB" models : (VEP56148B is used as a Main P.C.B.)]

\*.From the beginning, only "EG, EP, EF and EB" are displayed as model suffix lists, and these are displayed from the second times as well.

### CAUTION 2:(Stored picture image data in the unit)

This unit employs "Built-in Memory" for picture image data recording. (Approx.70MB)

After proceeding "INITIAL SETTINGS", the picture image data stored in the unit is erased.

#### 2. PROCEDURES:

• Precautions: Read the above "CAUTION 1" and "CAUTION 2", carefully.

• Preparation:

- Attach the Battery or AC Adaptor with a DC coupler to the unit.

(Since this unit has built-in memory, it can be performed without inserting SD memory card.)

1. Set the REC/PLAY switch to "[ REC ] (Camera mark)", and then turn the Power on.

2. Press the [ MODE ] button, and select the [ NORMAL PICTURE ] mode by Cursor buttons, then press the [ MENU/SET ] button.

3. Turn the Power off.

(If the unit is other than [ NORMAL PICTURE ] mode, it does not display the initial settings menu.)

• **Step 1. The temporary cancellation of "INITIAL SETTINGS":**

Set the REC/PLAY switch to "[ REC ] (Camera mark)".

While pressing "[ UP ] of Cursor button" and [ MOTION PICTURE ] button simultaneously, turn the Power on.

• **Step 2. The cancellation of "INITIAL SETTINGS":**

Set the REC/PLAY switch to "[ PLAY ]".

Press "[ UP ] of Cursor button" and [ MOTION PICTURE ] button simultaneously, turn the Power off.

The LCD displays the " ! " mark before the unit powers down.



• **Step 3. Turn the Power on:**

Set the REC/PLAY switch to "[ REC ] (Camera mark)", and then turn the Power on.

• **Step 4. Display the INITIAL SETTING:**

While pressing [ MENU/SET ] button and “[ RIGHT ] of Cursor button” simultaneously, turn the Power off.

The “INITIAL SETTINGS” menu is displayed.

There are two kinds of “INITIAL SETTINGS” menu form as follows:

[CASE 1. After replacing MAIN P.C.B.]

[Except “EG, EP, EF and EB” models: VEP56148A is used as a Main P.C.B.]

When MAIN P.C.B. has just been replaced, 20 model suffixes is displayed as follows. (Four pages in total)



[Only “EG, EP, EF and EB” models: VEP56148B is used as a Main P.C.B.]

When MAIN P.C.B. has just been replaced, only 6 model suffixes is displayed as follows. (two pages in total)



[CASE 2. Other than “After replacing MAIN P.C.B.”]



• **Step 5. Choose the model suffix in “INITIAL SETTINGS”: (Refer to “CAUTION 1”)**

[Caution: After replacing MAIN P.C.B.]

The model suffix can be chosen, **JUST ONE TIME**.

Once one of the model suffix have been chosen, the model suffix lists will not be displayed, thus, it can not be changed.

Therefore, select the area carefully.

Select the area with pressing “[ UP ] / [ DOWN ] of Cursor buttons”.

• **Step 6. Set the model suffix in “INITIAL SETTINGS”:**

Press the “[ RIGHT ] of Cursor buttons”.

The only set area is displayed, and then press the “[ RIGHT ] of Cursor buttons” after confirmation.

(The unit is powered off automatically.)

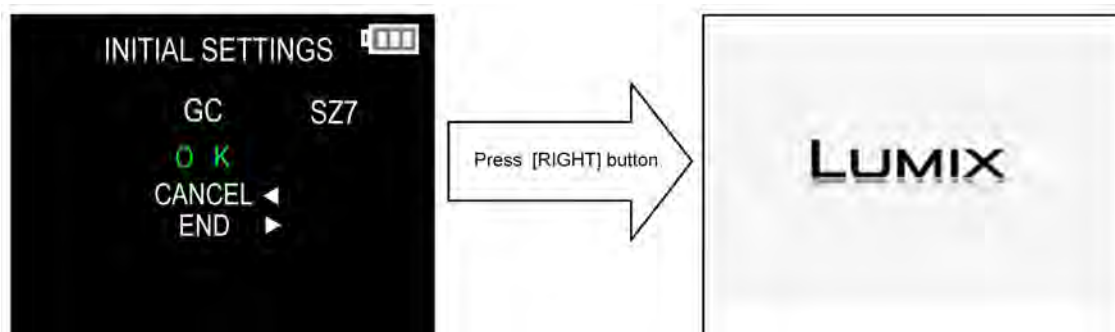

• **Step 7. CONFIRMATION:**

Confirm the display of “PLEASE SET THE CLOCK” in concerned language when the unit is turned on again.

When the unit is connected to PC with USB cable, it is detected as removable media.

(When the “GK” model suffix is selected, the display shows “PLEASE SET THE CLOCK” in Chinese.)

1) As for your reference, major default setting condition is as shown in the following table.

• **Default setting (After “INITIAL SETTINGS”)**

|    | MODEL                         | VIDEO OUTPUT | LANGUAGE             | DATE            | REMARKS |
|----|-------------------------------|--------------|----------------------|-----------------|---------|
| a) | DMC-SZ7(Japan domestic model) | NTSC         | Japanese             | Year/Month/Date |         |
| b) | DMC-SZ7P                      | NTSC         | English              | Month/Date/Year |         |
| c) | DMC-SZ7PC                     | NTSC         | English              | Month/Date/Year |         |
| d) | DMC-SZ7PU                     | NTSC         | Spanish              | Month/Date/Year |         |
| e) | DMC-SZ7EG                     | PAL          | English              | Date/Month/Year |         |
| f) | DMC-SZ7EP                     | PAL          | English              | Date/Month/Year |         |
| g) | DMC-SZ7EF                     | PAL          | French               | Date/Month/Year |         |
| h) | DMC-SZ7EB                     | PAL          | English              | Date/Month/Year |         |
| i) | DMC-SZ7EE                     | PAL          | Russian              | Date/Month/Year |         |
| j) | DMC-SZ7GC                     | PAL          | English              | Date/Month/Year |         |
| k) | DMC-SZ7GF                     | PAL          | English              | Date/Month/Year |         |
| l) | DMC-SZ7GA                     | PAL          | English              | Date/Month/Year |         |
| m) | DMC-SZ7GK                     | PAL          | Chinese (simplified) | Year/Month/Date |         |
| n) | DMC-SZ7GN                     | PAL          | English              | Date/Month/Year |         |

# 4 Specifications

## Digital Camera:

Information for your safety

|                           |   |
|---------------------------|---|
| <b>Power Source:</b>      | DC 5.1 V  |
| <b>Power Consumption:</b> | 1.3 W (When recording)<br>0.9 W (When playing back) |

|                                |   |   |
|--------------------------------|---|---|
| <b>Camera effective pixels</b> | 14,100,000 pixels   |   |
| <b>Image sensor</b>            | 1/2.33" MOS sensor, total pixel number 15,300,000 pixels, Primary color filter  |   |
| <b>Lens</b>                    | Optical 10× zoom, f=4.5 mm to 45 mm (35 mm film camera equivalent: 25 mm to 250 mm)/F3.1 (Wide) to F5.9 (Tele)  |   |
| <b>Image stabilizer</b>        | Optical method  |   |
| <b>Focus range</b>             | Normal  | 50 cm (1.6 feet) (Wide)/1.5 m (4.9 feet) (Tele) to ∞<br>[9× is 2 m (6.6 feet) to ∞] |
|                                | Macro/ Intelligent auto/ Motion picture   | 5 cm (0.16 feet) (Wide)/1.5 m (4.9 feet) (Tele) to ∞<br>[9× is 2 m (6.6 feet) to ∞] |
|                                | Scene Mode  | There may be differences in the above settings.                                     |
| <b>Shutter system</b>          | Electronic shutter+Mechanical shutter   |   |
| <b>Minimum illumination</b>    | [NTSC areas]<br>Approx. 8 lx (when i-low light is used, the shutter speed is 1/30th of a second)<br>[PAL areas]<br>Approx. 8 lx (when i-low light is used, the shutter speed is 1/25th of a second) |   |
| <b>Shutter speed</b>           | 8 seconds to 1/1600th of a second   |   |
| <b>Exposure (AE)</b>           | Auto (Program AE)   |   |
| <b>Metering mode</b>           | Multiple  |   |
| <b>LCD monitor</b>             | 3.0" TFT LCD (4:3)<br>(Approx. 460,000 dots) (field of view ratio about 100%)   |   |
| <b>Microphone</b>              | Stereo  |   |
| <b>Speaker</b>                 | Monaural  |   |
| <b>Recording media</b>         | Built-in Memory (Approx. 70 MB)/SD Memory Card/<br>SDHC Memory Card/SDXC Memory Card  |   |

|   |   |
|---|---|
| <b>Recording file format</b>                          |   |
| <b>Still Picture</b>                                  | JPEG (based on "Design rule for Camera File system", based on "Exif 2.3" standard)/DPOF corresponding/MPO |
| <b>Motion pictures</b>                                | AVCHD/MP4   |
| <b>Audio compression format</b>                       | AVCHD: Dolby Digital (2ch)<br>MP4: AAC (2ch)  |
| <b>Interface</b>                                      |   |
| <b>Digital</b>  | "USB 2.0" (High Speed)  |
| <b>Analog video</b>                                   | [NTSC areas]<br>NTSC<br>[PAL areas]<br>NTSC/PAL Composite (Switched by menu)                              |
| <b>Audio</b>  | Audio line output (monaural)  |
| <b>Terminal</b>                                       |   |
| <b>[AV OUT/DIGITAL]</b>                               | Dedicated jack (8 pin)  |
| <b>[HDMI]</b>   | MiniHDMI TypeC  |
| <b>Dimensions</b><br>(excluding the projecting parts) | Approx. 99.0 mm (W)×59.4 mm (H)×21.0 mm (D)<br>[3.9"(W)×2.4"(H)×0.9"(D)]                                  |
| <b>Mass (weight)</b>                                  | Approx. 133 g/0.30 lb (with card and battery)<br>Approx. 116 g/0.26 lb (excluding card and battery)       |
| <b>Operating temperature</b>                          | 0 °C to 40 °C (32 °F to 104 °F)   |
| <b>Operating humidity</b>                             | 10%RH to 80%RH  |

## AC Adaptor:

Information for your safety

|                |                                   |
|----------------|-----------------------------------|
| <b>Input:</b>  | ~ 110 V to 240 V, 50/60 Hz, 0.2 A |
| <b>Output:</b> | === 5 V, 800 mA                   |

## Battery Pack (lithium-ion):

Information for your safety

|                          |               |
|--------------------------|---------------|
| <b>Voltage/capacity:</b> | 3.6 V/680 mAh |
|--------------------------|---------------|

## NOTE:(Only for "EB/EF/EG/EP" models)

- Data from the PC can not be written to the camera using the USB connection cable.

# 5 Location of Controls and Components

- 1 Flash
- 2 Lens
- 3 Self-timer indicator  
AF Assist Lamp

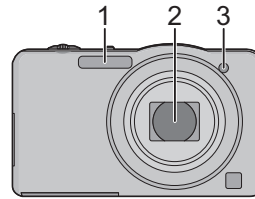

- 4 LCD monitor
- 5 [MENU/SET] button
- 6 [DISP.] button
- 7 [Q.MENU]/[/↵] (Delete/Cancel) button
- 8 [MODE] button
- 9 REC/PLAY switch
- 10 Charging lamp

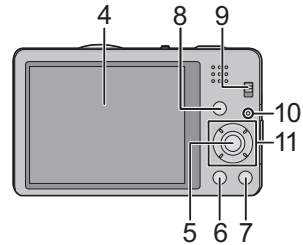

- 11 Cursor buttons
- Ⓐ: ▲/Exposure compensation
- Ⓑ: ▼/Macro Mode  
AF Tracking
- Ⓒ: ◀/Self-timer
- Ⓓ: ▶/Flash setting

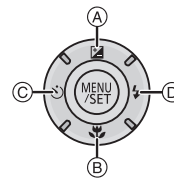

- 12 Strap eyelet
- Be sure to attach the strap when using the camera to ensure that you will not drop it.
- 13 Lens barrel
- 14 [HDMI] socket
- 15 [AV OUT/DIGITAL] socket

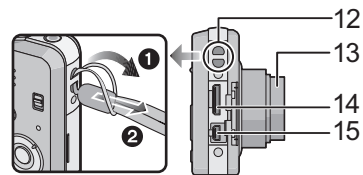

- 16 Speaker
- Be careful not to cover the speaker with your finger. Doing so may make sound difficult to hear.
- 17 Camera ON/OFF switch
- 18 Zoom lever
- 19 Microphone
- 20 Shutter button
- 21 Motion picture button
- 22 Tripod receptacle
- 23 Card/Battery door
- 24 Release lever

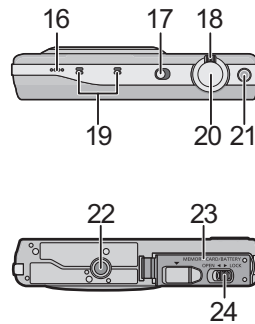

## Selecting the Recording Mode

1 Slide the REC/PLAY switch to [📷].

2 Press [MODE].

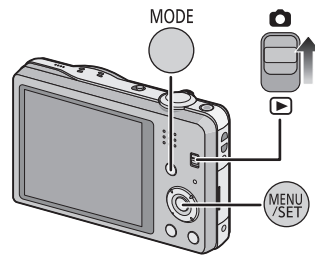

3 Press ▲/▼/◀/▶ to select the Recording Mode.



4 Press [MENU/SET].

### ■ List of Recording Modes

|   |
|---|
| <b>iA Intelligent Auto Mode</b>   |
| The subjects are recorded using settings automatically selected by the camera.  |
| <b>📷 Normal Picture Mode</b>  |
| The subjects are recorded using your own settings.  |
| <b>📷 Miniature Effect Mode</b>  |
| This is an imaging effect which defocuses the surroundings to make it look like a diorama. (also known as Tilt Shift Focus) |
| <b>SCN Scene Mode</b>   |
| This allows you to take pictures that match the scene being recorded.   |
| <b>3D 3D Photo Mode</b>   |
| Takes a 3D picture.   |

### 📌 Note

- When the mode has been switched from Playback Mode to Recording Mode, the previously set Recording Mode will be set.

# 6 Service Mode

## 6.1. Error Code Memory Function

### 1. General description

This unit is equipped with history of error code memory function, and can be memorized 16 error codes in sequence from the latest. When the error is occurred more than 16, the oldest error is overwritten in sequence.

The error code is not memorized when the power supply is shut down forcibly (i.e.,when the unit is powered on by the battery, the battery is pulled out) The error code is memorized to FLASH-ROM when the unit has just before powered off.

### 2. How to display

The error code can be displayed by ordering the following procedure:

• Preparation

- Attach the Battery or AC Adaptor with a DC coupler to the unit.

(Since this unit has built-in memory, it can be performed without inserting SD memory card.)

1. Set the REC/PLAY switch to "[ REC ] (Camera mark)", and then turn the Power on.

2. Press the [ MODE ] button, and select the [ NORMAL PICTURE ] mode by Cursor buttons, then press the [ MENU/SET ] button.

3. Turn the Power off.

(If the unit is other than [ NORMAL PICTURE ] mode, it does not display the initial settings menu.)

• **Step 1. The temporary cancellation of "INITIAL SETTINGS":**

Set the REC/PLAY switch to "[ REC ] (Camera mark)".

While pressing "[ UP ] of Cursor button" and [ MOTION PICTURE ] button simultaneously, turn the Power on.

• **Step 2. Execute the error code display mode:**

Press the "[ LEFT ] of Cursor button" , [ MENU/SET ] button and [ MOTION PICTURE ] button simultaneously.

The display is changed as shown below when the above buttons are pressed simultaneously.

Normal display → Error code display → Operation history display →Normal display →.....

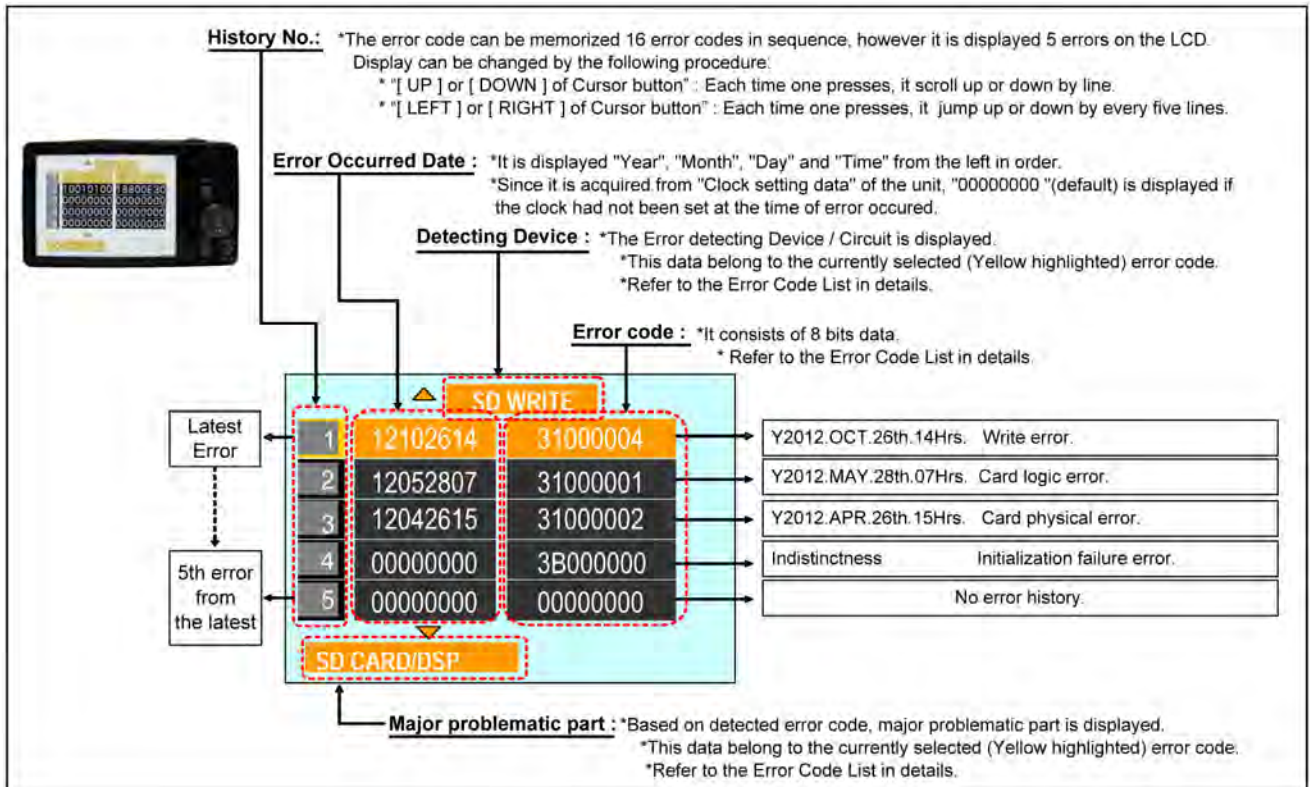

Example of Error Code Display

• 3. Error Code List

The error code consists of 8 bits data and it shows the following information.

| Attribute | Main item   | Sub item  | Error code      |   | Contents (Upper line)  | Error Indication   |  |   |             |      |   |          |              |
|-----------|---|---|-----------------|---|--|--|--|---|-------------|------|---|----------|--------------|
|           |   |   | High 4 bits     | Low 4 bits  | Problematic Part & Check point (Lower line)  | Detecting device   | Problematic Part/Circuit   |   |             |      |   |          |              |
| LENS      | Lens drive  | OIS   | 18*0            | 1000  | PSD (X) error. Hall element (X axis) position detect error in OIS unit.<br>OIS Unit  | OIS X  | LENSu NG   |   |             |      |   |          |              |
|           |   |   |                 | 2000  | PSD (Y) error. Hall element (Y axis) position detect error in OIS unit.<br>OIS Unit  | OIS Y  |  |   |             |      |   |          |              |
|           |   |   | 3000            | GYRO (X) error. Gyro (IC7101: X axis) detect error on Sub P.C.B..<br>IC7101 (Gyro element) or IC6001 (VENUS ENGINE) | GYRO X   | GYRO NG  |  |   |             |      |   |          |              |
|           |   |   |                 | 4000  | GYRO (Y) error. Gyro (IC7101: Y axis) detect error on Sub P.C.B..<br>IC7101 (Gyro element) or IC6001 (VENUS ENGINE)  |  | GYRO Y   |   |             |      |   |          |              |
|           |   |   | 5000            | MREF error (Reference voltage error).<br>IC9101 (SYSTEM) or IC6001 (VENUS ENGINE)                                   | OIS REF  | LENSsD/DSP NG  |  |   |             |      |   |          |              |
|           |   |   |                 | 6000  | Drive voltage (X) error.<br>LENS Unit, LENS flex breaks, IC6001 (VENUS ENGINE) AD value error,   |  | OISX REF   |   |             |      |   |          |              |
|           |   |   | 7000            | Drive voltage (Y) error.<br>LENS Unit, LENS flex breaks, IC6001 (VENUS ENGINE) AD value error,                      | OISY REF   | LENSu/LENS FPC   |  |   |             |      |   |          |              |
|           |   |   |                 | Zoom  | 0710   |  | Collapsible barrel Low detect error<br>(Collapsible barrel encoder always detects Low.)<br>Mechanical lock, FP9002-(40) signal line or IC6001 (VENUS ENGINE) | ZOOM L  | ZOOMm/LENSu |      |   |          |              |
|           |   |   | 0720            |   | Collapsible barrel High detect error<br>(Collapsible barrel encoder always detects High.)<br>Mechanical lock, FP9002-(40) signal line or IC6001 (VENUS ENGINE) | ZOOM H   |  |   |             |      |   |          |              |
|           |   |   | 0730            |   | Zoom motor sensor error.<br>Mechanical lock, FP9002-(34), (37) signal line or IC6001 (VENUS ENGINE)  | ZOOM ENC   |  |   |             |      |   |          |              |
|           |   | 0740  |                 |   | Zoom motor sensor error. (During monitor mode.)<br>Mechanical lock, FP9002-(34), (37) signal line or IC6001 (VENUS ENGINE)                                     |  |  |   |             |      |   |          |              |
|           |   | 0750  |                 |   | Zoom motor sensor error. (During monitor mode with slow speed.)<br>Mechanical lock, FP9002-(34), (37) signal line or IC6001 (VENUS ENGINE)                     |  |  |   |             |      |   |          |              |
|           |   | Focus   | 0701            |   | HP Low detect error<br>(Focus encoder always detects High, and not becomes Low)<br>Mechanical lock, FP9002-(40) signal line or IC6001 (VENUS ENGINE)           | FOCUS L  | LENS FPC/DSP   |   |             |      |   |          |              |
|           |   |   | 0702            |   | HP High detect error<br>(Focus encoder always detects Low, and not becomes High)<br>Mechanical lock, FP9002-(40) signal line or IC6001 (VENUS ENGINE)          | FOCUS H  |  |   |             |      |   |          |              |
|           |   | Lens  | 18*1            | 0000  | Power ON time out error.<br>Lens drive system  | LENS DRV   | LENSu  |   |             |      |   |          |              |
|           |   |   |                 | 0000  | Power OFF time out error.<br>Lens drive system   |  |  |   |             |      |   |          |              |
|           |   | Adj. History  | OIS             | 19*0  | 2000   | OIS adj. Yaw direction amplitude error (small)                       | OIS ADJ  | OIS ADJ   |             |      |   |          |              |
|           |   |   |                 |   | 3000   | OIS adj. Pitch direction amplitude error (small)                     |  |   |             |      |   |          |              |
|           |   |   |                 |   | 4000   | OIS adj. Yaw direction amplitude error (large)                       |  |   |             |      |   |          |              |
|           |   |   |                 |   | 5000   | OIS adj. Pitch direction amplitude error (large)                     |  |   |             |      |   |          |              |
|           | 6000  |   |                 |   | OIS adj. MREF error  |  |  |   |             |      |   |          |              |
|           | 7000  |   |                 |   | OIS adj. time out error  |  |  |   |             |      |   |          |              |
|           | 8000  |   |                 |   | OIS adj. Yaw direction off set error   |  |  |   |             |      |   |          |              |
|           | 9000  |   |                 |   | OIS adj. Pitch direction off set error   |  |  |   |             |      |   |          |              |
|           | A000  |   |                 |   | OIS adj. Yaw direction gain error  |  |  |   |             |      |   |          |              |
|           | B000  |   |                 |   | OIS adj. Pitch direction gain error  |  |  |   |             |      |   |          |              |
|           | C000  |   |                 |   | OIS adj. Yaw direction position sensor error   |  |  |   |             |      |   |          |              |
|           | D000  |   |                 |   | OIS adj. Pitch direction position sensor error   |  |  |   |             |      |   |          |              |
|           | E000  |   |                 |   | OIS adj. other error   |  |  |   |             |      |   |          |              |
|           | HARD  |   |                 |   | VENUS A/D  | Flash  |  |   | 28*0        | 0000 | Flash charging error.<br>IC6001-(Y22) signal line or Flash charging circuit | STRB CHG | STRB PCB/FPC |
|           |   |   |                 |   | FLASH ROM (EEPROM Area)  | FLASH ROM (EEPROM Area)  |  |   | 2B*0        | 0001 | EEPROM read error<br>IC6002 (FLASH ROM)                                     | FROM RE  | FROM         |
|           |   |   |                 |   |  |  |  |   |             | 0002 | EEPROM write error<br>IC6002 (FLASH ROM)                                    | FROM WR  | FROM         |
| 0005      |   | Firmware version up error<br>Replace the firmware file in the SD memory card. | (No indication) | (No indication)   |  |  |  |   |             |      |   |          |              |
| 0008      |   | SDRAM error   |                 |   |  |  |  |   |             |      |   |          |              |
| 0009      |   | SDRAM Mounting defective  |                 |   |  |  |  |   |             |      |   |          |              |
| SYSTEM    |   | RTC   | 2C*0            | 0001  | SYSTEM IC initialize failure error<br>Communication between IC6001 (VENUS ENGINE) and IC9101 (SYSTEM)  | SYS INIT   | MAIN PCB   |   |             |      |   |          |              |
| SOFT      |   | CPU   | Reset           | 30*0  | 0001   | NMI reset  | NMI RST  | MAIN PCB  |             |      |   |          |              |
|           |   |   |                 |   | 0007   | Non Mask-able Interrupt<br>(30000001-30000007 are caused by factors) |  |   |             |      |   |          |              |
|           |   | Card  | Card            | 31*0  | 0001   | Card logic error   | SD CARD  | SD CARD/DSP   |             |      |   |          |              |
|           | SD memory card data line or IC6001 (VENUS ENGINE) |   |                 |   |  |  |  |   |             |      |   |          |              |
|           | 0002  |   |                 |   | Card physical error  |  |  |   |             |      |   |          |              |
|           |   |   |                 |   | SD memory card data line or IC6001 (VENUS ENGINE)  |  |  |   |             |      |   |          |              |
|           | 0004  | Write error   | SD WRITE        |   |  |  |  |   |             |      |   |          |              |
|           |   | SD memory card data line or IC6001 (VENUS ENGINE)                             |                 |   |  |  |  |   |             |      |   |          |              |
|           | CPU, ASIC hard                                    | Stop  | 38*0            | 0001  | Camera task finish process time out.   | LENS COM   | LENSu/DSP  |   |             |      |   |          |              |
|           |   |   |                 |   | Communication between Lens system and IC6001 (VENUS ENGINE)  |  |  |   |             |      |   |          |              |
|           |   |   |                 |   | 0002   |  |  | Camera task invalid code error.<br>IC6001 (VENUS ENGINE)                    |             |      |   |          |              |
|           |   |   |                 |   | 0100   |  |  | File time out error in recording motion image<br>IC6001 (VENUS ENGINE)      |             |      |   |          |              |
|           |   |   |                 |   |  |  |  | File data cue send error in recording motion image<br>IC6001 (VENUS ENGINE) |             |      |   |          |              |
|           |   |   |                 |   | 0200   |  |  | Single or burst recording brake time out.                                   |             |      |   |          |              |
|           | 0300  | USB work area partitioning failure  | (No indication) | (No indication)   |  |  |  |   |             |      |   |          |              |
|           |   | USB dynamic memory securing failure when connecting                           |                 |   |  |  |  |   |             |      |   |          |              |
| Operation | Power on  | 3B*0  | 0000            | FLASH ROM processing early period of camera during movement.  | INIT   | (No indication)  |  |   |             |      |   |          |              |
| Zoom      | Zoom  | 3C*0  | 0000            | Inperfect zoom lens processing  | ZOOM   | ZOOMm/LENSu  |  |   |             |      |   |          |              |
|           |   |   |                 | Zoom lens   |  |  |  |   |             |      |   |          |              |
|           |   |   | 35*0            | 0000  | Software error<br>(0-7bit : command, 8-15bit : status)   | DSP  | DSP  |   |             |      |   |          |              |
|           |   |   |                 | FFFF  |  |  |  |   |             |      |   |          |              |
| 35*1      | 0000  | Though record preprocessing is necessary, it is not called.                   | (No indication) | (No indication)   |  |  |  |   |             |      |   |          |              |
|           | 0000  | Though record preprocessing is necessary, it is not completed.                |                 |   |  |  |  |   |             |      |   |          |              |

## **Important notice about "Error Code List"**

### **1) About "\*" indication:**

The third digit from the left is different as follows.

- In case of 0 (example: 18001000)

When the third digit from the left shows "0", this error occurred under the condition of INITIAL SETTINGS has been completed.

It means that this error is occurred basically at user side.

- In case of 8 (example: 18801000)

When the third digit from the left shows "8", this error occurred under the condition of INITIAL SETTINGS has been released.

(Example; Factory assembling-line before unit shipment, Service mode etc.)

It means that this error is occurred at service side.

### **2) About "?" indication: ("18\*0 0?01" to "18\*0 0?60"):**

The third digit from the right shows one of the hexadecimal ("0" to "F") character.

### **• 4. How to exit from Error Code display mode:**

Simply, turn the power off. (Since Error code display mode is executed under the condition of temporary cancellation of "INITIAL SETTINGS", it wake up with normal condition when turn off the power.)







#### **NOTE:**

The error code can not be initialized.

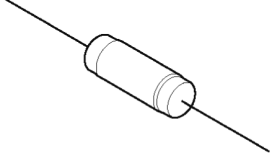
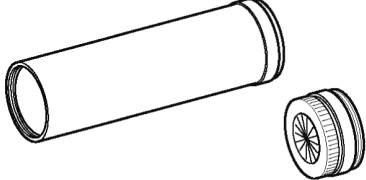
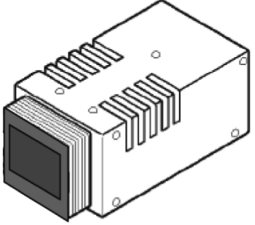
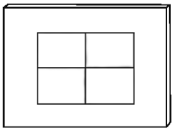
# 7 Service Fixture & Tools

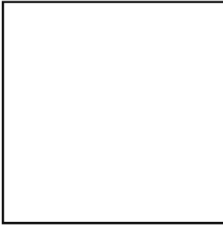
## 7.1. Service Fixture and Tools

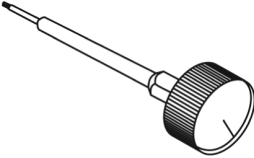
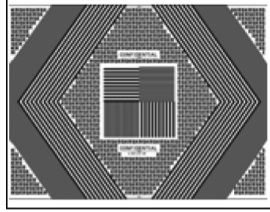
The following Service Fixture and tools are used for checking and servicing this unit.

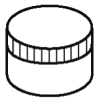
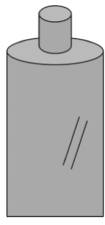
|  |  |   |
|--|--|---|
| Resistor for Discharging (1kΩ/5W)<br><b>ERG5SJ102</b>  | Collimator (with Focus Chart)<br><b>VFK1164TCM02</b>   | LIGHT BOX (with DC Cable)<br><b>RFKZ0523</b>  |
|  <p>An equivalent type of Resistor may be used.</p> |  <p>*VFK1164TCM03 can be used.<br/>*RFKZ0422 can be used.</p> |  <p>*VFK1164TDVLB can be used.</p> |
| TR Chart<br><b>RFKZ0443</b>  | Lens Cleaning Kit (BK)<br><b>VFK1900BK</b>   | ND Filter (ND0.3)<br><b>RFKZ0513</b>  |
|   |  <p>*Only supplied 10 set/box.</p>                            |                                    |
| Diffuser<br><b>RFKZ0591</b>  | Driver (for optical axis adjustment)<br><b>RFKZ0569</b>  | Optical axis adjustment chart<br><b>RFKZ0570</b>  |
|   |   |                                  |
| Camera stand<br><b>RFKZ0333J</b>   | Driver (for Lens)<br><b>VFK1390</b>  | Grease (for Lens)<br><b>RFKZ0472</b>  |
|   |   |                                  |
| Screw locking glue<br><b>RFKZ0573</b>  |  |   |
|   |  |   |

## 7.2. When Replacing the Main P.C.B.

After replacing the MAIN P.C.B., be sure to achieve adjustment.

The service software is available at "TSN Website". To download, click on "Support Information from NWBG/VDBG-AVC".

## 7.3. Service Position

This Service Position is used for checking and replacing parts. Use the following Extension cables for servicing.

Table S1 Extension Cable List

| No. | Parts No. | Connection                             | Form         |
|-----|-----------|--|--------------|
| 1   | RFKZ0553  | PS9001 (MAIN) - PP9501 (SUB OPERATION) | 16PIN B to B |
| 2   | RFKZ0418  | PP9001 (MAIN) - PS8001 (FLASH TOP)     | 30PIN B to B |

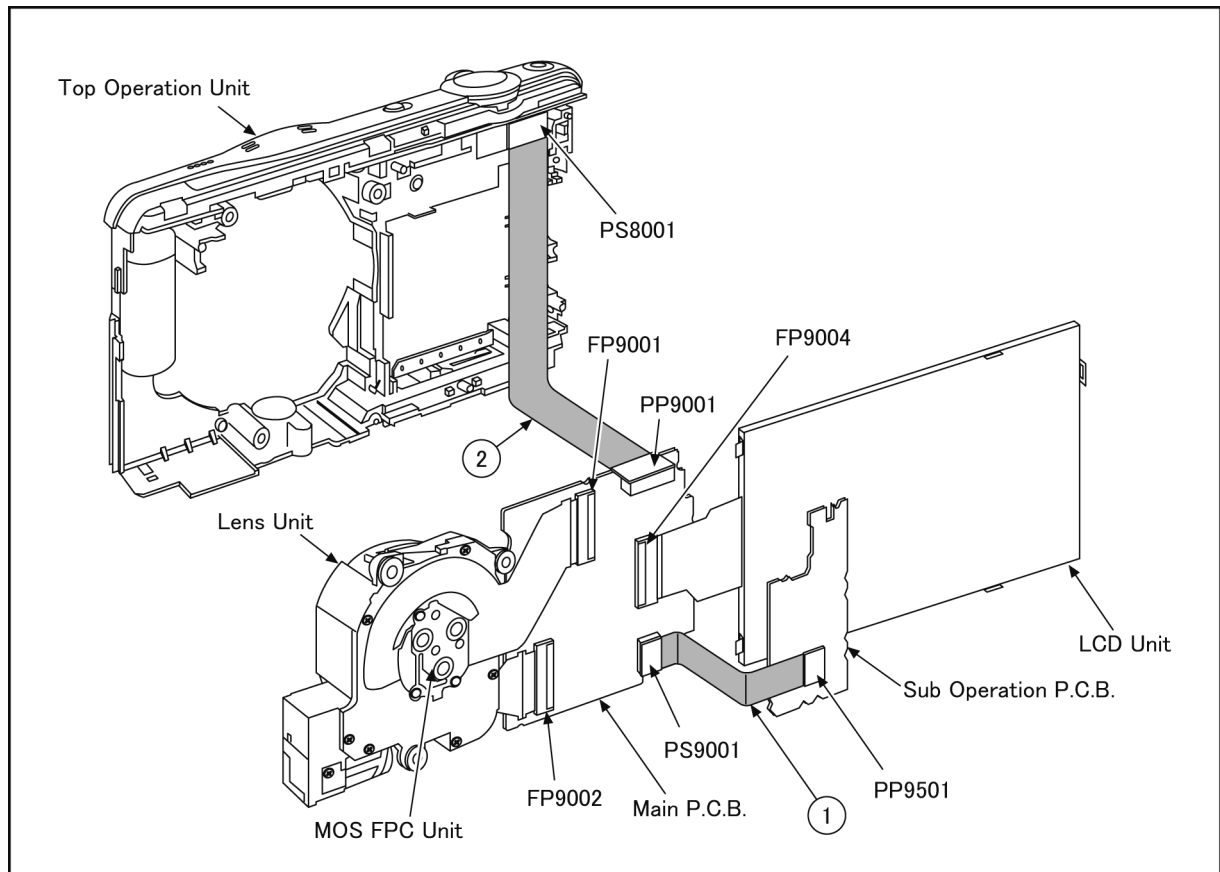

### CAUTION-1. (When servicing FLASH TOP P.C.B.)

1. Be sure to discharge the E.capacitor on FLASH TOP P.C.B..

Refer to "HOW TO DISCHARGE THE E.CAPACITOR ON FLASH TOP P.C.B.".

The E.capacitor voltage is not lowered soon even if the AC Cord is unplugged or the battery is removed.

2. Be careful of the high voltage circuit on FLASH TOP P.C.B..
3. DO NOT allow other parts to touch the high voltage circuit on FLASH TOP P.C.B..

# 8 Disassembly and Assembly Instructions

## 8.1. Disassembly Flow Chart

This is a disassembling chart.

When assembling, perform this chart conversely.

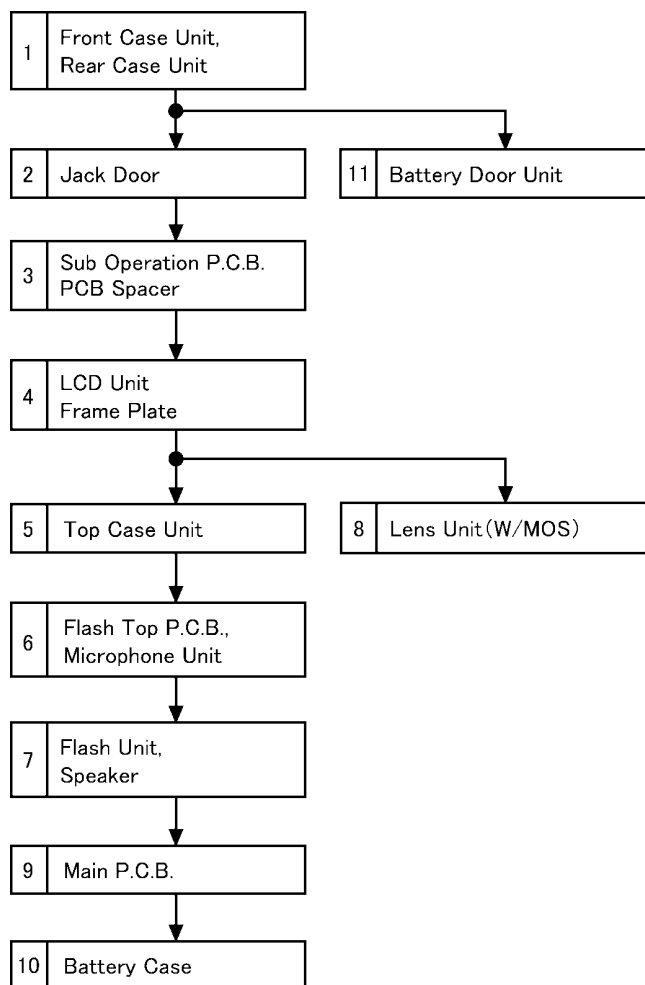

## 8.2. P.C.B. Location

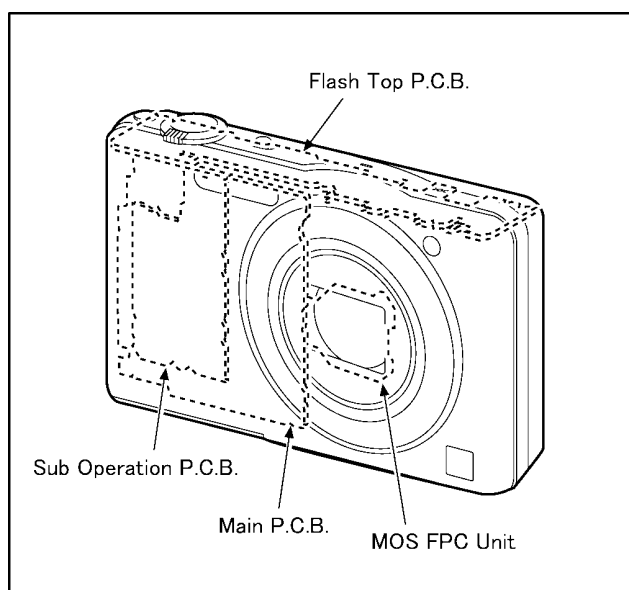

## 8.3. Disassembly Procedure

| No. | Item                                | Fig        | Removal   |
|-----|-------------------------------------|------------|---|
| 1   | Front Case Unit<br>Rear Case Unit   | (Fig. D1)  | Card<br>Battery<br>3 Screws (A)<br>1 Screw (B)<br>2 Screws (C)  |
|     |                                     | (Fig. D2)  | 4 Locking tabs<br>Front Case Unit<br>4 Locking tabs<br>Rear Case Unit   |
| 2   | Jack Door                           | (Fig. D3)  | 1 Groove<br>1 Locking tab<br>Side Ornament (R)<br>2 Locking tabs<br>Side Ornament (L)<br>Jack Door  |
| 3   | Sub Operation P.C.B.<br>PCB Spacer  | (Fig. D4)  | PP9501(Connector)<br>Sub Operation P.C.B.<br>2 Locking tabs<br>PCB Spacer   |
| 4   | LCD Unit<br>Frame Plate             | (Fig. D5)  | 1 Locking tab<br>FP9004(Flex)<br>LCD Unit<br>3 Locking tabs<br>Frame Plate  |
| 5   | Top Case Unit                       | (Fig. D6)  | PS8001(Connector)<br>AF Panel Light<br>Top Case Unit  |
| 6   | Flash Top P.C.B.<br>Microphone Unit | (Fig. D7)  | 2 Screws (D)<br>FP8051(Flex)<br>3 Locking tabs<br>Flash Top P.C.B.<br>2 Locking tabs<br>Power Knob<br>2 Convexes<br>REC Button<br>Microphone Unit |
|     |                                     | (Fig. D8)  | Discharge the E.capacitor   |
| 7   | Flash Unit<br>Speaker               | (Fig. D9)  | 3 Solders<br>Flash Unit<br>2 Solders<br>Speaker   |
| 8   | Lens Unit (W/MOS)                   | (Fig. D10) | DPR Sheet<br>FP9001(Flex)<br>FPC Tape<br>FP9002(Flex)<br>Lens Unit (W/MOS)  |
| 9   | Main P.C.B.                         | (Fig. D11) | 1 Screw (E)<br>1 Convex<br>Main P.C.B.  |
| 10  | Battery Case                        | (Fig. D12) | 1 Locking tab<br>Battery Out Spring<br>4 Locking tabs<br>Battery Case   |
| 11  | Battery Door Unit                   | (Fig. D13) | Battery Lock Knob<br>Battery Lock Spring<br>Battery Door Unit   |

### 8.3.1. Removal of the Front Case Unit and Rear Case Unit

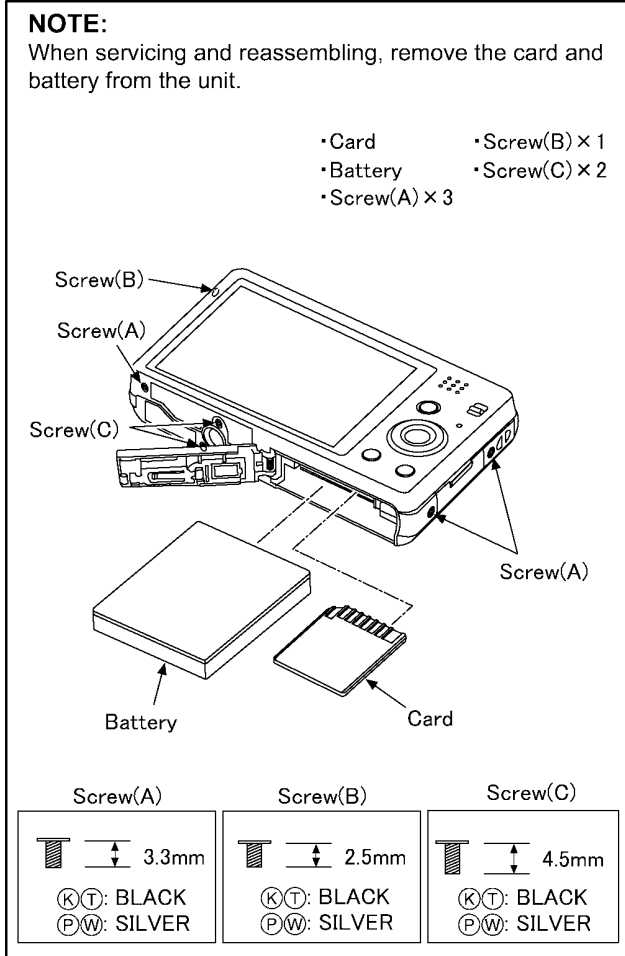

(Fig. D1)

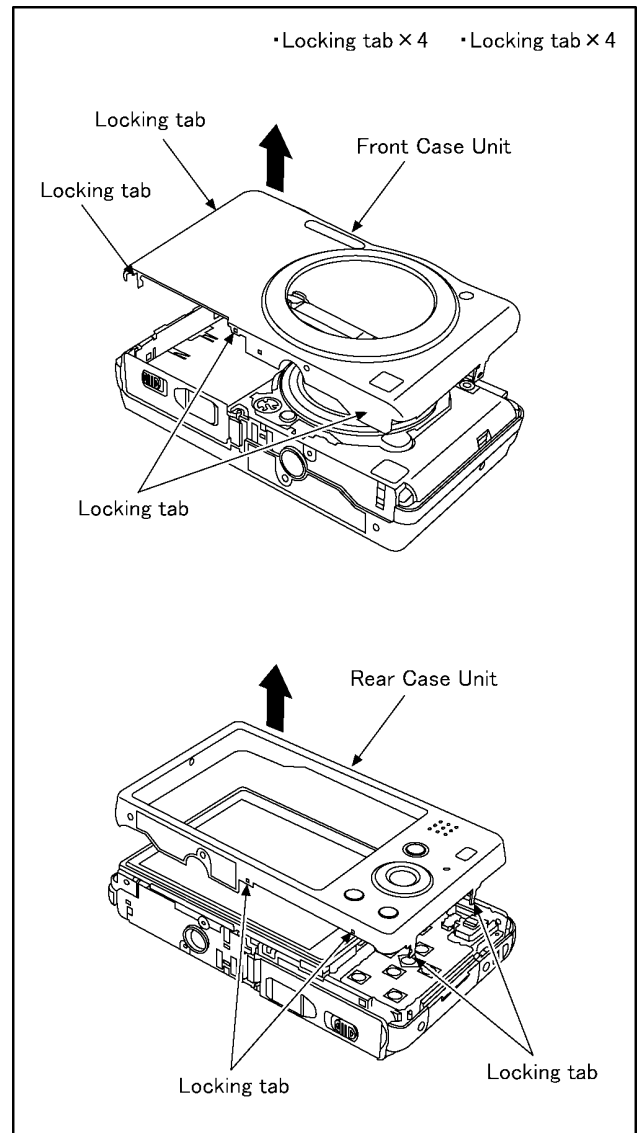

(Fig. D2)

### 8.3.2. Removal of the Jack Door

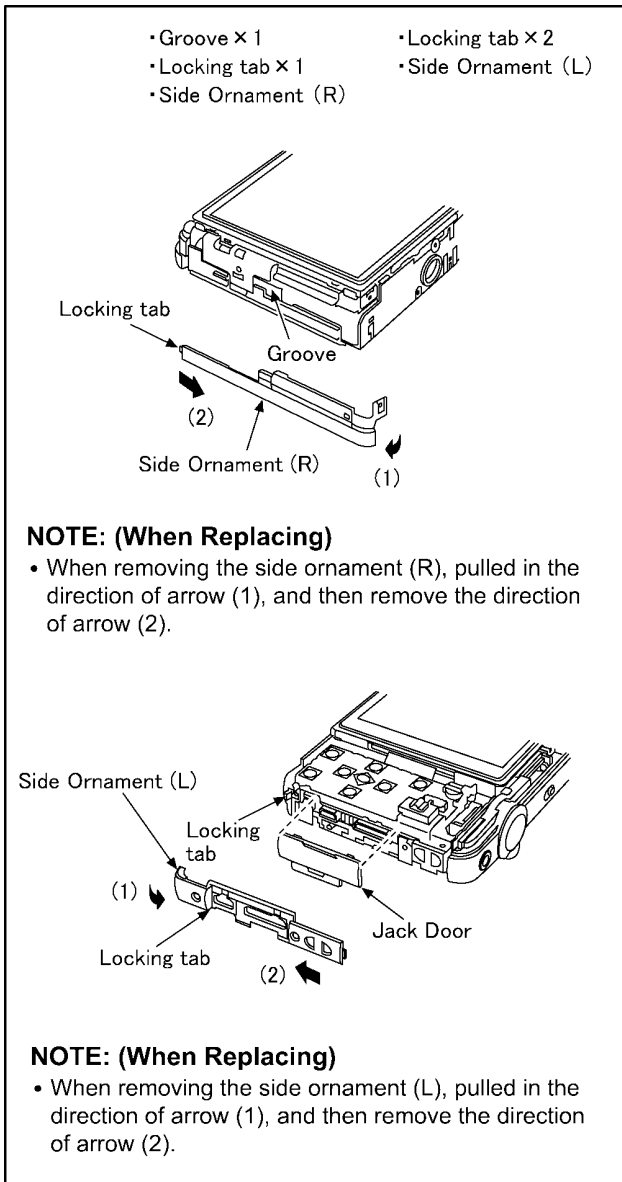

(Fig. D3)

### 8.3.3. Removal of the Sub Operation P.C.B. and PCB Spacer

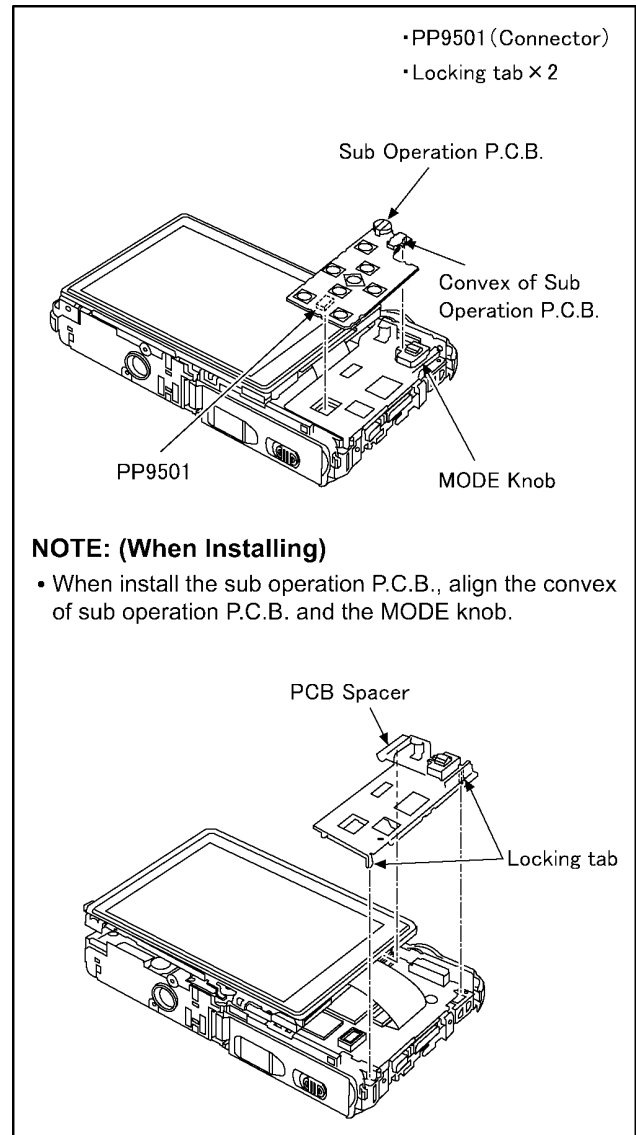

(Fig. D4)

### 8.3.4. Removal of the LCD Unit and Frame Plate

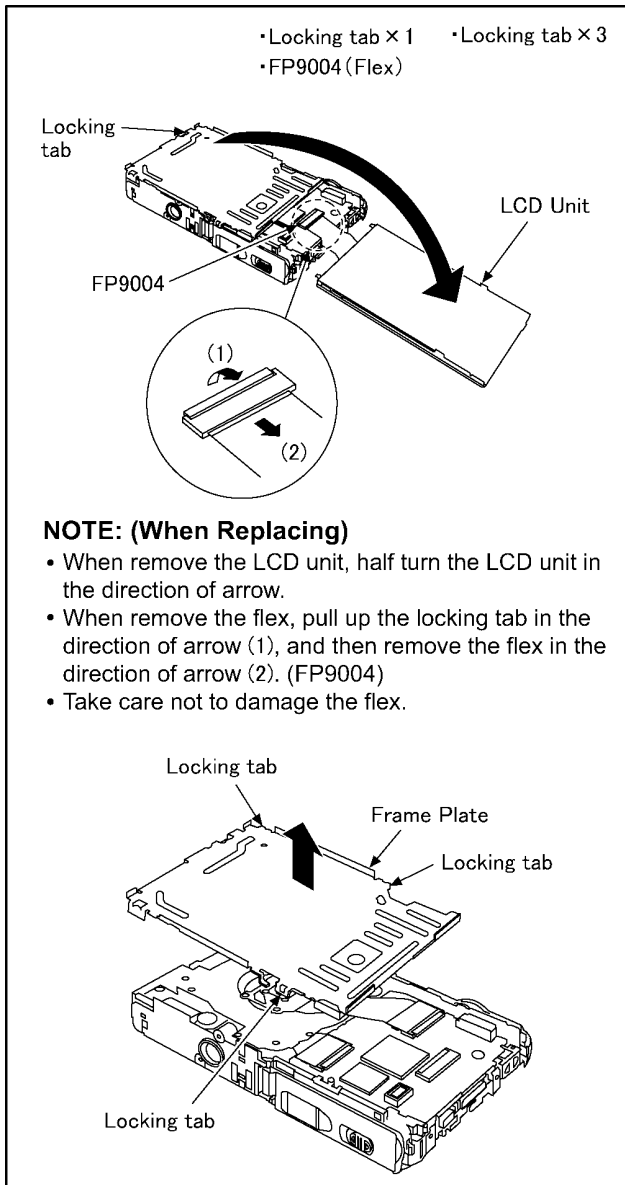

(Fig. D5)

### 8.3.5. Removal of the Top Case Unit

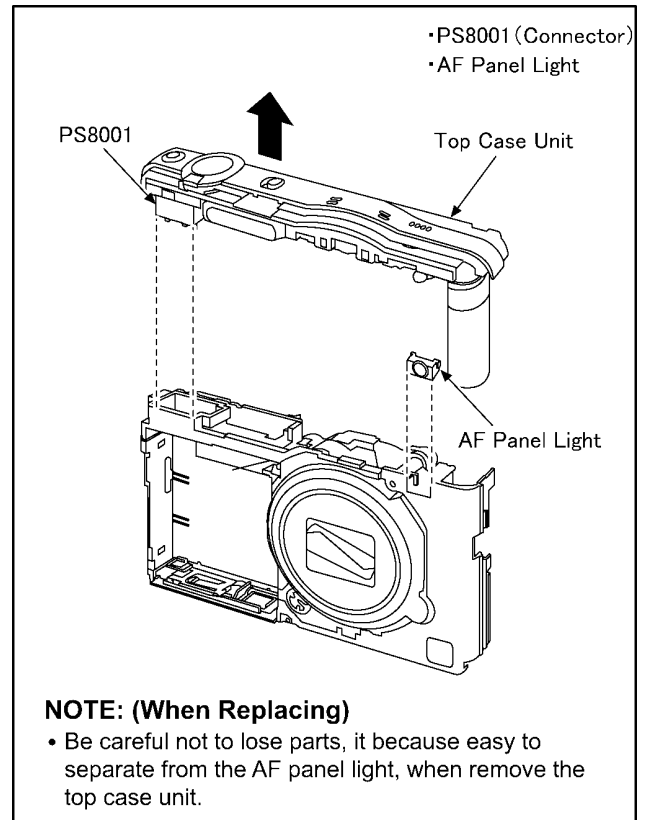

(Fig. D6)

### 8.3.6. Removal of the Flash Top P.C.B. and Microphone Unit

#### IMPORTANT NOTICE:

Take care not apply any bending load to the charging capacitor. It brings about the possibility of P.C.B. and/or component damage on the Flash Top P.C.B..

- Screw(D) × 2
- FP8051 (Flex)
- Locking tab × 3
- Locking tab × 2
- Power Knob
- Convex × 2
- REC Button

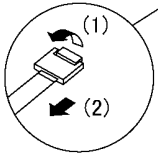
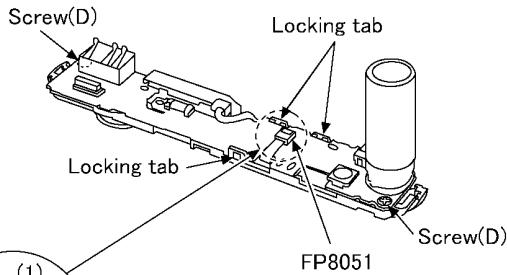

#### NOTE: (When Replacing)

- When remove the flex, pull up the locking tab in the direction of arrow (1), and then remove the flex in the direction of arrow (2). (FP8051)
- Take care not to damage the flex.

Screw(D)

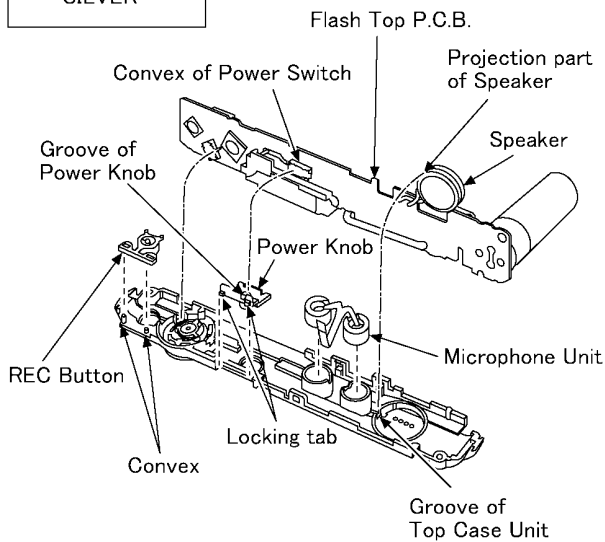
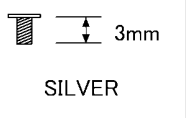

#### NOTE: (When Installing)

1. Align the convex of power switch and groove of power knob.
2. Insert the projection part of speaker to the groove of top case unit.

(Fig. D7)

#### IMPORTANT NOTICE:

Take care not apply any bending load to the charging capacitor. It brings about the possibility of P.C.B. and/or component damage on the Flash Top P.C.B..

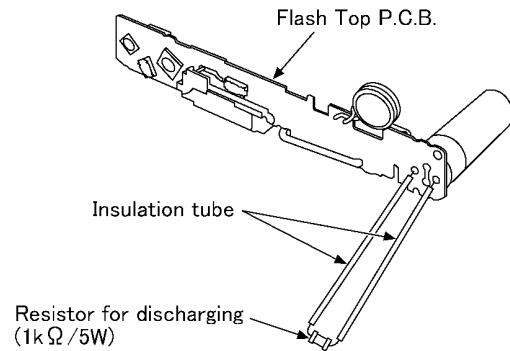

#### CAUTION

Be sure to discharge the E.capacitor on Flash Top P.C.B. before disassembling.

1. Put the insulation tube on the lead part of resistor (ERG5SJ102: 1kΩ/5W).
2. Put the resistor between both terminals of capacitor unit for approx. 5 seconds.

(Fig. D8)

### 8.3.7. Removal of the Flash Unit and Speaker

#### IMPORTANT NOTICE:

Take care not apply any bending load to the charging capacitor. It brings about the possibility of P.C.B. and/or component damage on the Flash Top P.C.B..

- Sloder × 3 points
- Sloder × 2 points

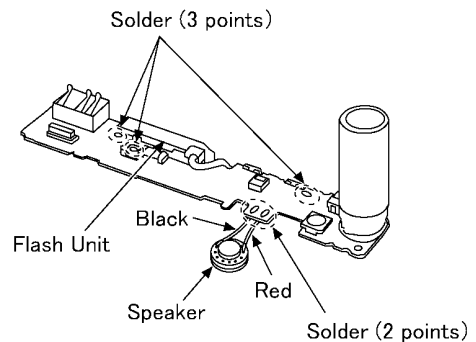

(Fig. D9)

### 8.3.8. Removal of the Lens Unit (W/MOS)

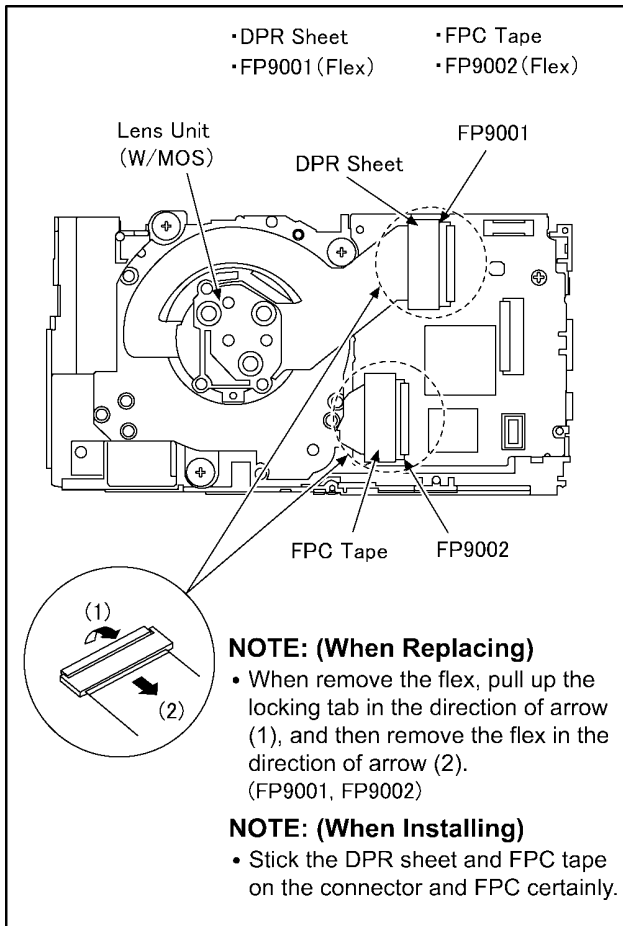

(Fig. D10)

### 8.3.9. Removal of the Main P.C.B.

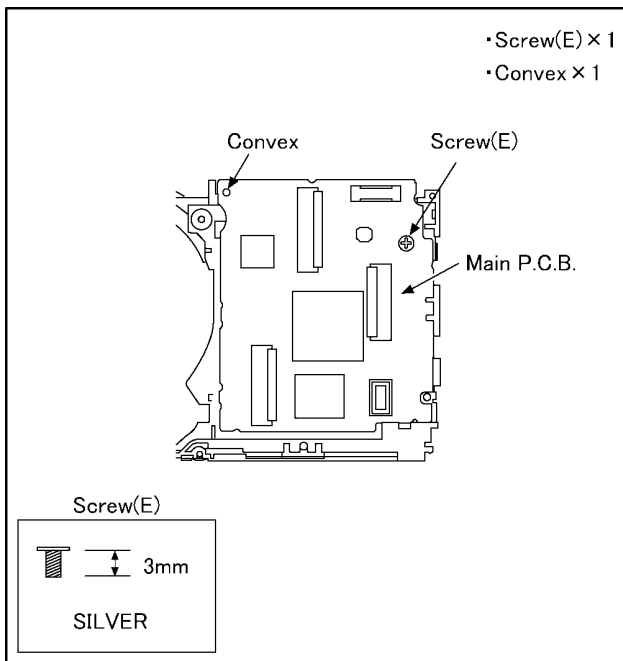

(Fig. D11)

### 8.3.10. Removal of the Battery Case

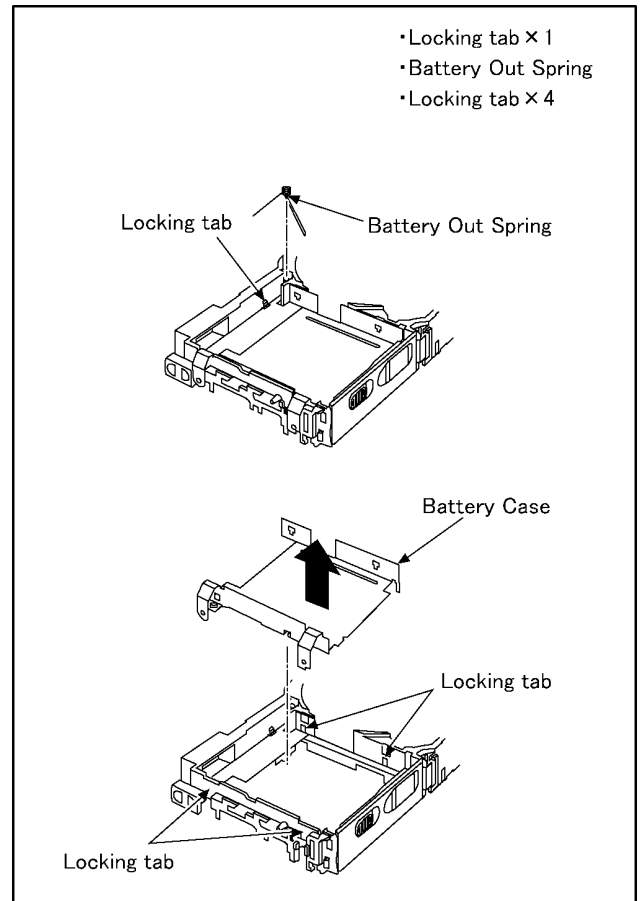

(Fig. D12)

### 8.3.11. Removal of the Battery Door Unit

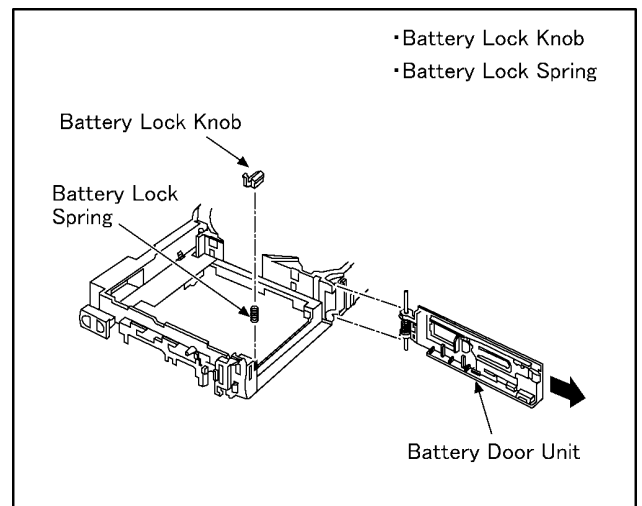

(Fig. D13)

**NOTE: (When Installing)**

Make sure to confirm the following points when installing:

- The Screw is tightened enough.
- Installing conditions are fine. (No distortion, no abnormal-space.)
- No dust and/or dirt on Lens surfaces.
- LCD image is fine. (No dust and dirt on it, and no gradient images.)

## 8.4. Lens Disassembly Procedure

### Precaution:

1. Do not remove the MOS FPC unit when disassembling or reassembling the lens in order to maintain it clean.  
The screw fitting the MOS FPC unit to the master flange unit is fixed by the bond lock with the adjustment of the installation angle of the MOS FPC unit against the lens (optical axis adjustment) finished.  
When remove it, refer to item "8.7."
2. Keep dust or dirt away from the lens.  
To remove dirt or dust from the lens, blow with dry air.
3. Do not touch the lens surface.
4. Use lens cleaning KIT (VFK1900BK).
5. Apply grease (RFKZ0472) as shown on "THE APPLICATION OF GREASE METHOD" in the figure.

### 8.4.1. Removal of the Zoom Motor Unit and Lens FPC Unit

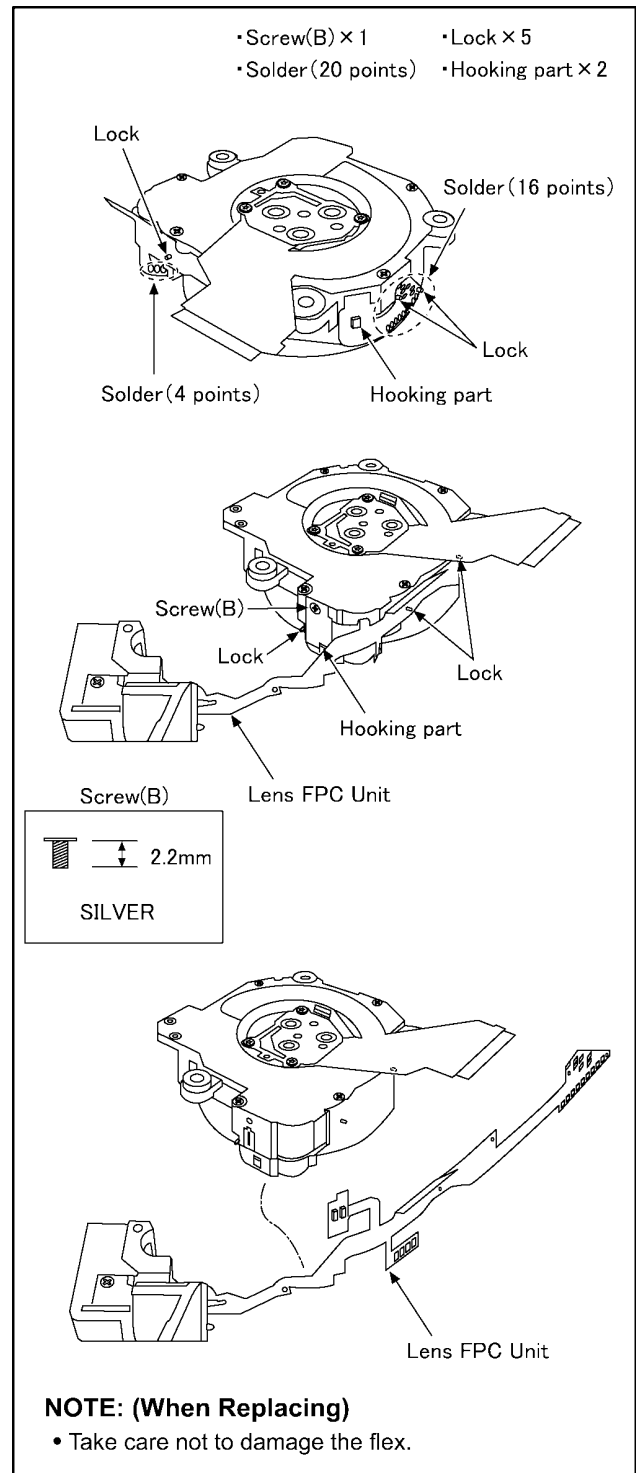
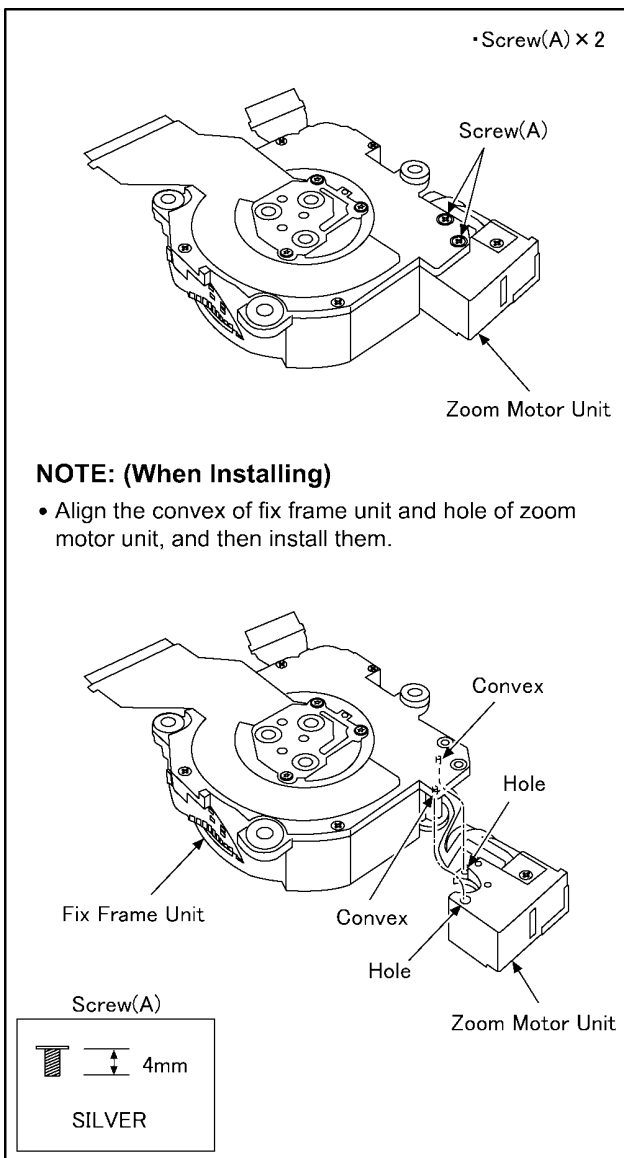

### 8.4.2. Removal of the Master Flange Unit

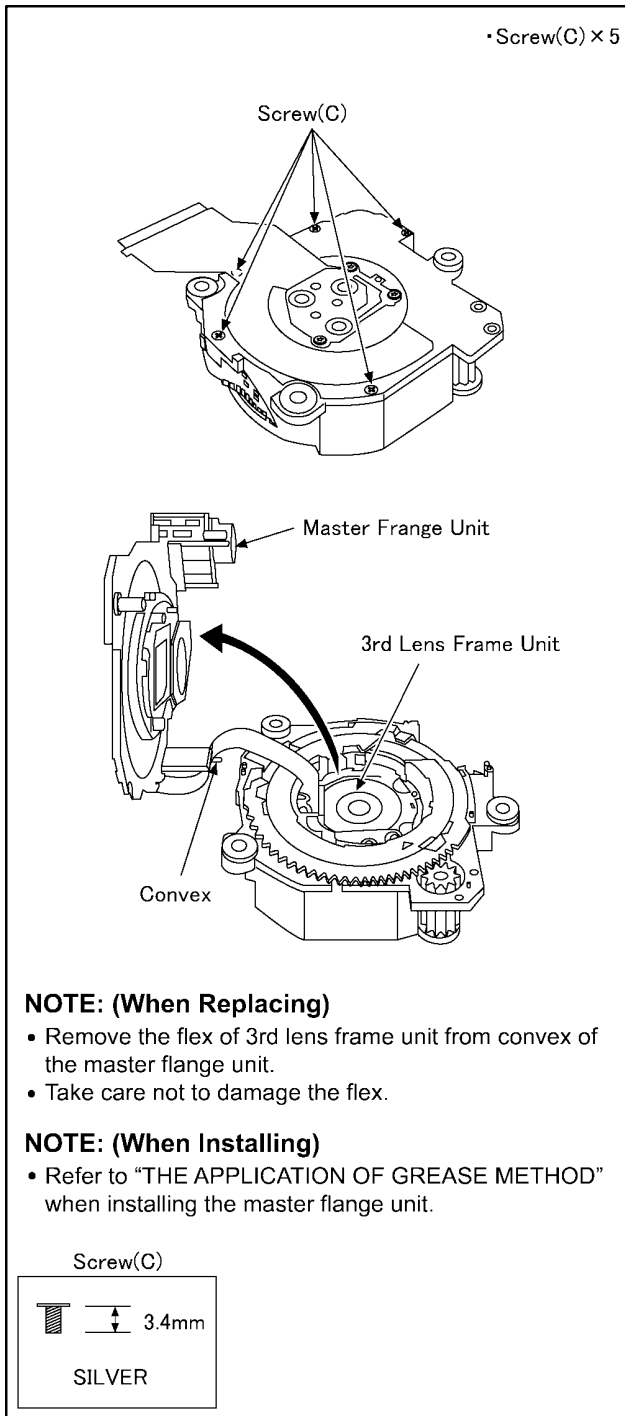

### 8.4.3. Removal of the Outside Direct Frame Unit / 1st-3rd Lens Frame Unit

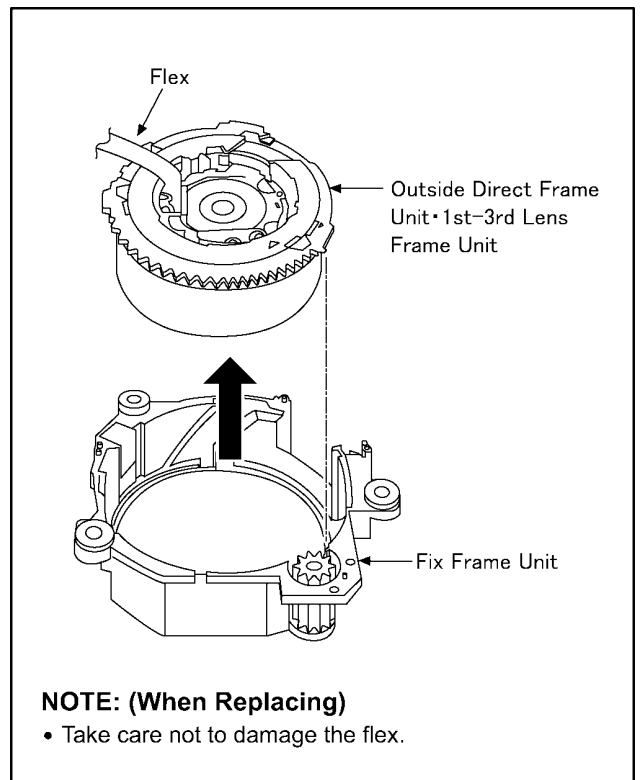

### 8.4.4. 1st-3rd Lens Frame Unit

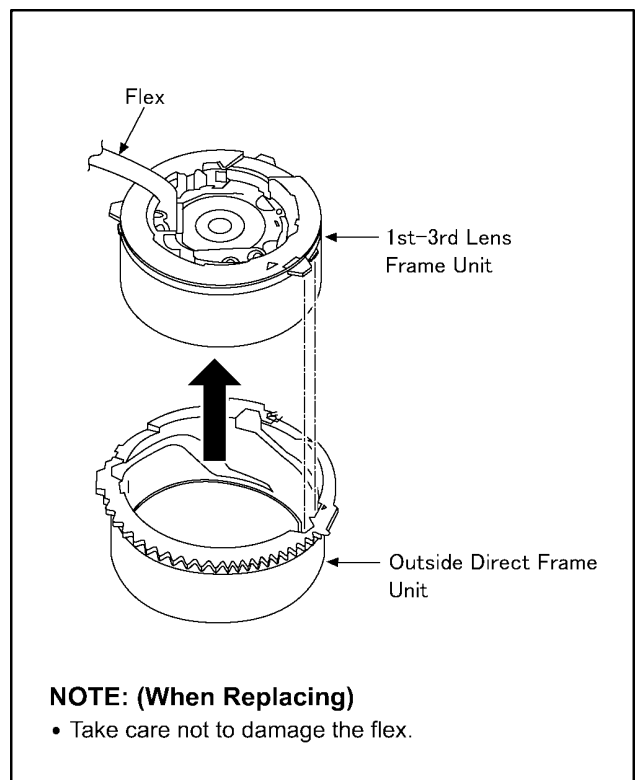

## 8.5. Removal of the Focus Motor

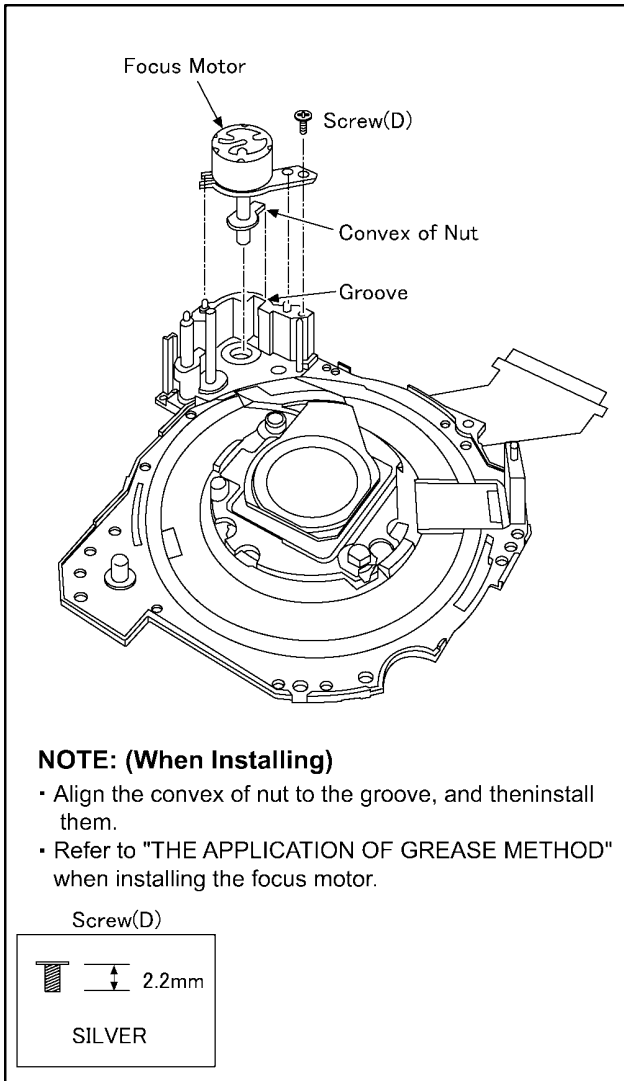

## 8.6. The Application of Grease Method

The grease application parts of lens unit are as follows.  
Apply grease additionally in the specified position if necessary.  
When the grease is applied, use a toothpick and apply thinly.

- Focus motor nut sliding part
  - Grease: RFKZ0472
  - Amount of application: 1.5 - 2 mg
- 4th Lens Frame sub shaft
  - Grease: RFKZ0472
  - Amount of application: 0.5 - 1 mg
- Lead screw
  - Grease: RFKZ0472
  - Amount of application: 2 - 4 mg
- 4th Lens Frame spindle guide
  - Grease: RFKZ0472
  - Amount of application: 1 - 2 mg

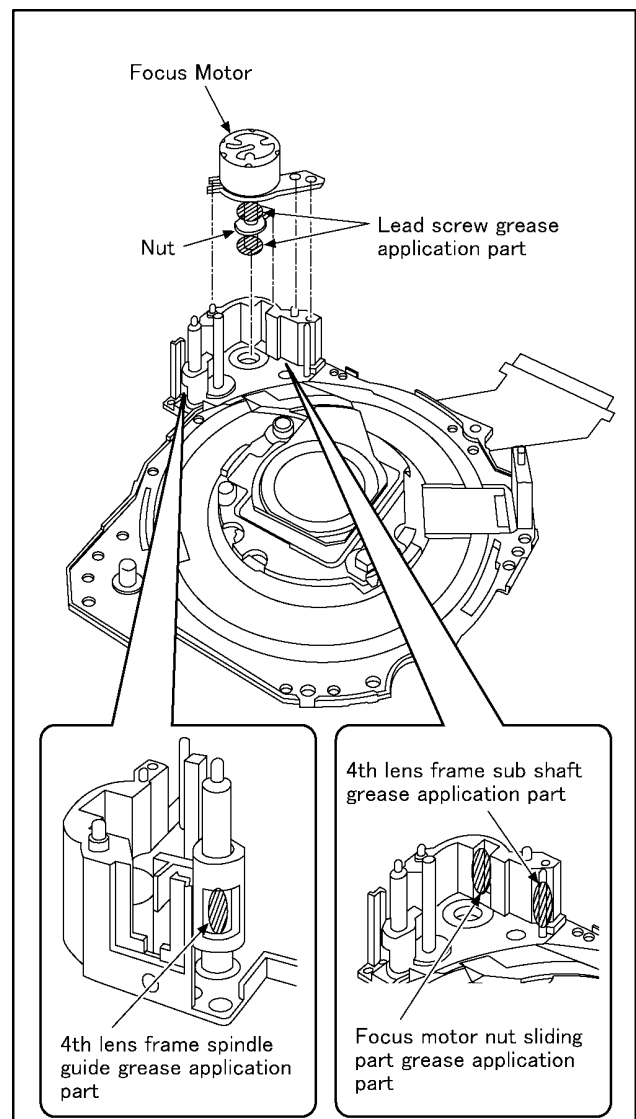

## 8.7. Removal of the MOS FPC Unit

When remove the MOS FPC unit once (the screw(E) is loosened even a little), the optical tilt adjustment is required.

When loosen the screw(E), necessary the optical tilt adjustment at the end of assembling. (Refer to item "9.3.2.")

To prevent the MOS FPC unit from catching the dust and dirt, do not remove the MOS FPC unit except for replacing.

### ■ CAUTION

- The screw(E) is fixed by the screw locking glue with the optical tilt adjustment finished. When remove the MOS FPC unit, wipe the screw locking glue away carefully.
- Don't reuse the screw(E) that the screw locking glue adheres to keep dust or dirt away from the MOS FPC unit. (When installing, use new screw(E).)

- Screw (E) × 3
- Tilt Spring × 2

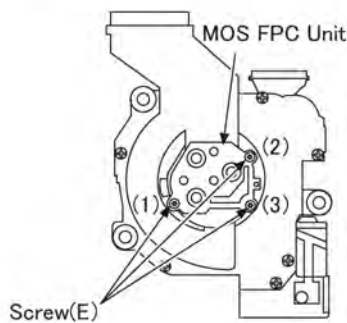

Screw(E)

- Screws(1)(2) are for adjustment, screw(3) is for fix.

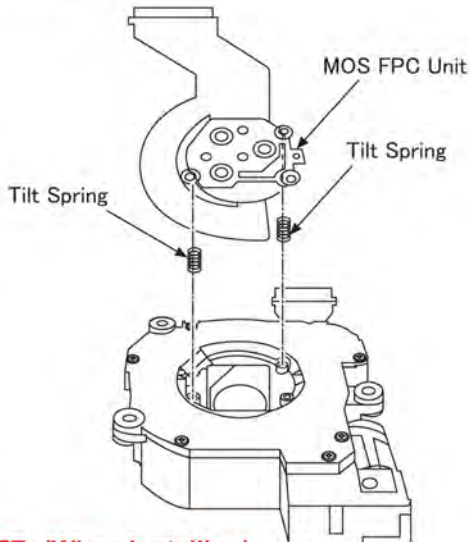
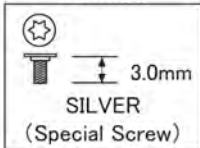

### NOTE: (When Installing)

- Take new screw.  
(Don't reuse the screw that the screw locking glue adheres.)
- Be sure to execute the optical tilt adjustment with the screw (1) and (2).
- Tighten the 3 special screws in order (1)→(2)→(3).
- Screw torque: 5 N·cm.
- After the adjustment is finished, apply the screw locking glue as shown on the next item in the figure.

- Remove screw locking glue for services to clean the bond curing UV, so as to straddle the place of the original application.  
(Do not adhere locking glue to the head of tilt screw)

(Example)

This is the case where the screw locking glue is applied to inside of the broken line.

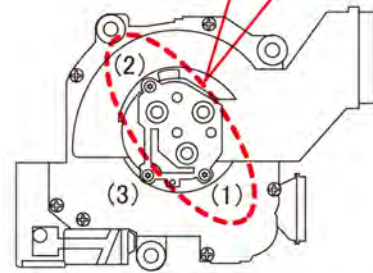
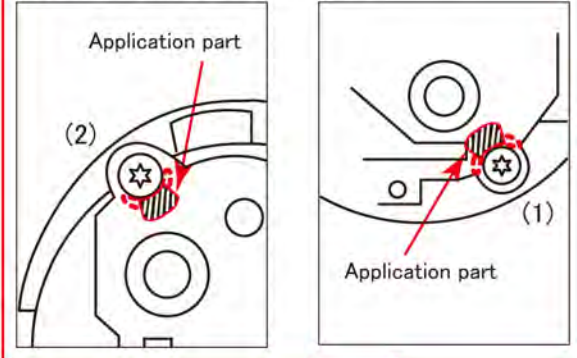

# 9 Measurements and Adjustments

## 9.1. Introduction

When servicing this unit, make sure to perform the adjustments necessary based on the part(s) replaced. Before disassembling the unit, it is recommended to back up the camera data stored in flash-rom as a data file.

### **IMPORTANT NOTICE (After replacing the MAIN P.C.B.)**

After replacing the MAIN P.C.B., it is necessary to use the "DIAS" software to allow the release of adjustment flag(s).

The Adjustment software "DIAS" is available at "TSN Website". To download, click on "Support Information from NWBG/VDBG-AVC".

\*DIAS (DSC Integrated Assist Software)

### **NOTE: (When replacing the Lens unit and MOS FPC unit)**

- When the MOS FPC unit is unavoidably removed for Lens unit, Master Flange unit and MOS FPC unit replaced, an optical tilt adjustment is necessary after parts are exchanged.
- The adjustment software (DSC\_Tilt) is necessary to execute an optical tilt adjustment.
- The adjustment software "DSC\_Tilt" is available at "TSN Website", therefore, access to "TSN Website" at "Support Information from NWBG/VDBG-AVC".

## 9.2. Before Disassembling the unit

### 9.2.1. Initial Setting Release

The cameras specification are initially set in accordance with model suffix (such as EB, EG, GK, GC, and so on.).

Unless the initial setting is not released, an automatic alignment software in the camera is not able to be executed when the alignment is carried out.

#### **Note:**

The initial setting should be again done after completing the alignment. Otherwise, the camera may not work properly.

Therefore as a warning, the camera display a warning symbol "!" on the LCD monitor every time the camera is turned off.

Refer to the procedure described in "3.5.2 INITIAL SETTINGS" for details.

#### **[ How to Release the camera initial setting ]**

##### **Preparation:**

- Attach the Battery or AC Adaptor with a DC coupler to the unit.
  1. Set the REC/PLAY switch to "[ REC ] (Camera mark)", and then turn the Power on.
  2. Press the [ MODE ] button, and select the [ NORMAL PICTURE ] mode by Cursor buttons, then press the [ MENU/SET ] button.
  3. Turn the Power off.  
(If the unit is other than [ NORMAL PICTURE ] mode, it does not display the initial settings menu.)

##### **Step 1. The temporary cancellation of "INITIAL SETTINGS":**

Set the REC/PLAY switch to "[ REC ] (Camera mark)".

While pressing "[ UP ] of Cursor button" and [ MOTION PICTURE ] button simultaneously, turn the Power on.

##### **Step 2. Cancellation of "INITIAL SETTINGS":**

Set the REC/PLAY switch to "[ PLAY ]".

Press "[ UP ] of Cursor button" and [ MOTION PICTURE ] button simultaneously, turn the Power off.

The LCD displays the "!" mark before the unit powers down.



## 9.2.2. Flash-Rom Data Backup

When trouble occurs, it is recommended to backup the Flash-rom data before disassembling the unit.

There are two kinds of Flash-rom data backup methods:

### [ ROM\_BACKUP (Method of Non-PC backup) ]

1. Insert the SD-card into the camera.
2. Set the camera to “Temporary cancellation of the initial settings”.
3. Select the “SETUP” menu.

From the “SETUP” menu, select “ROM BACKUP”.

#### NOTE:

This item is not listed on the customer's “SETUP” menu.

4. When this “ROM\_BACKUP” item is selected, the following submenus are displayed.



Fig.2-1



Fig.2-2



Fig.2-3

| Item                   | Function  | Details   |
|------------------------|---|---|
| DSC → SD               | Save all the DSC's Flash-rom data to SD-CARD  | *DSC's Flash-rom data is saved to the SD-CARD as a data file by the same format as the TATSUJIN software for the previous models. (DATA BACKUP)<br>-File location: ROOT DIRECTORY in SD-CARD.<br>-File Name:<br>1) User Setup Information data: <Model Number>U.txt [Example: DMC-FX66 : "FX66U.txt"]<br>2) Optical Adjustment data: <Model Number>F.txt [Example: DMC-FX66 : "FX66F.txt"]<br>*If the concerned file already exists, "OVERWRITE?" message is displayed. |
| SDALL → DSC (ID CHECK) | Write the all data to DSC's Flash-rom from SD-CARD  | *The backup data being stored in the SD card is transferred to DSC unit.<br>*ID CHECK: When the model ID is different, data is not transferred.   |
| SDALL → DSC (FORCE)    | Write the all data to DSC's Flash-rom from SD-CARD  | *FORCE: Even if the model ID is different, data is transferred.<br>※If the main PCB is replaced, select "SDALL → DSC (FORCE)".  |
| SDUSER → DSC (FORCE)   | Only "User setup information" is written from the saved file in the SD-CARD to DSC's Flash-rom. | *Only the user's "setup" setting condition is transferred to DSC unit.<br>*FORCE: Even if the model ID is different, the data is transferred.   |
| ! → LUMIX              | Shipping set without initializing "User setup information"                                      | *Initial setting is executed without initializing the user's set up setting condition.<br>※ The initial setting must be perform while the Self-timer LED is blinking,<br>※ The picture data stored in the built-in memory of the DSC is not erased, with this operation.  |

### [ DSC Integrated Assist Software (Method of Using PC) ]

Same as TATSUJIN software for previous models.

## 9.2.3. Light Box

If using VFK1164TDVLB Light Box, remove the lens connection ring by loosening three hexagon screws.

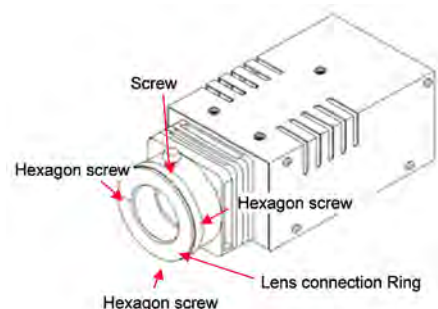

## 9.3. Details of Electrical Adjustment

### 9.3.1. How to execute the Electrical Adjustment

It is not necessary to connect the camera to a PC to perform adjustments.

“Flag reset operation” and “Initial setting operation” are required when carrying out the alignment, follow the procedure below.

#### 9.3.1.1. Startup Electrical Adjustment mode

1. Release the initial settings.
2. Insert a recordable SD card.  
(Without a SD card, the automatic adjustment can not executed.)
3. Procedure to set the camera into adjustment mode:
  - a. Set the REC/PLAY switch to “[ REC ] (Camera mark)”, and then turn the Power on.
  - b. Press the [ MODE ] button, and select the [ NORMAL PICTURE ] mode by Cursor button, then press the [ MENU/SET ] button.
  - c. Set the REC/PLAY switch to “[ REC ] (Camera mark)”, and then turn the Power off.
  - d. Turn the Power on pressing [ MENU/SET ] and [ MOTION PICTURE ] simultaneously.  
LCD monitor displays “SERVICE MODE”.(Refer to Fig. 3-1)

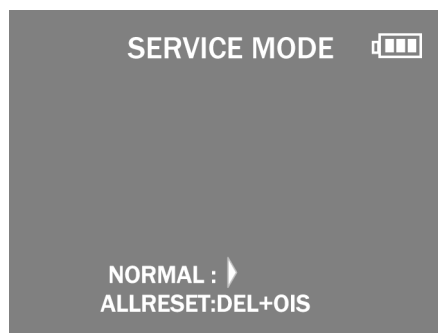

Fig.3-1

#### 9.3.1.2. Status Adjustment Flag Setting

Reset (Not yet adjusted) the status flag condition.

1. After pressing the [ DISP. ] button, the LCD monitor displays the Flag status screen (Refer to Fig.3-2)
2. Select item by pressing the Cursor buttons. (Gray cursor is moved accordingly.)
3. Press the [ Q.MENU ]/[ Delete/Cancel ] button.

**NOTE:**

The selected item's flag has been changed from “F (green)” to “0 (yellow)”.

\*Flag conditions:

F (green)

means that the alignment has been completed and the status flag condition is set. In this case, the flag condition should be reset, if you try to carry out the automatic alignment.

0 (yellow)

means that the alignment has been not “completed” and the status flag condition is “reset”. In this case, automatic alignment is available.

- In case of setting the status flag into set condition again without completion of the alignment, the status flag should be SET by using PC, or UNDO by using ROM BACKUP function.



Fig.3-2

### 9.3.1.3. Execute Adjustment (In case of “OIS Adjustment”)

1. Perform step “9.3.1.1.” to “9.3.1.2.”, to reset the OIS flag status “F” (Set) to “0” (Reset)
2. Press [ DISP. ] button after Flag reset.  
OIS Adjustment screen is displayed on the LCD panel.  
(Refer to Fig.3-3)
3. Press the [ Shutter ] button.  
The adjustment will start automatically.



Fig.3-3

4. When the adjustment is completed successfully, adjustment report menu appears with Green OK on the LCD monitor. (Refer to Fig.3-4)



Fig.3-4

### 9.3.1.4. Attention point during Adjustment

1. Step “9.3.1.3.” procedure shows OIS adjustment as an example. To perform the adjustment, refer to the “9.3.2. Adjustment Specifications” table which shows key point for each adjustment.
2. Do not move the light box, the camera or the chart while adjusting. If one of these is moved accidentally, start the adjustment again.
3. Do not press any buttons/keys until the default menu (Fig.3-5) is displayed on the LCD monitor. Otherwise, adjustment data may not be stored properly.
4. If the adjustment is interrupted accidentally, the alignment data may not be properly saved in the Flash-rom.

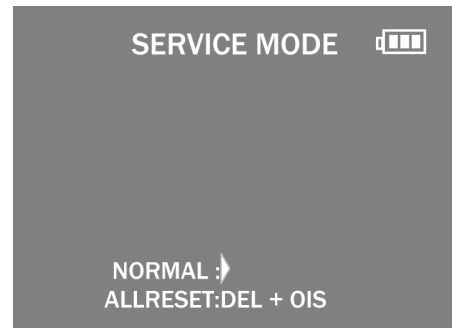

Fig.3-5

### 9.3.1.5. Finalizing the Adjustment

1. Several adjustment flags can be reset (“F” into “0”) at the same time. In this case, when the adjustment has been completed, the screen will change showing the adjustment for the next item until all reset items are completed.  
Also, when the [ Shutter ] button is pressed, the screen jump to the next adjustment item.
2. To cancel the adjustment mode while in the process of performing the adjustment, follow this procedures.  
(1) Press “[ Q.MENU ]/[ Delete/Cancel ] of Cursor button”.  
(2) Press “[ RIGHT ] of Cursor button”.

**NOTE:**

- If adjustment is cancelled with above procedure, adjustment is not completed. Make sure to adjust it later.
- Adjustment software “DIAS” is able to control the status of the adjustment flags.

### 9.3.2. Adjustment Specifications

The following matrix table shows the relation between the replaced part and the Necessary Adjustment.

When a part is replaced, make sure to perform the necessary adjustment(s) in the order indicated.

The table below shows all the information necessary to perform each adjustment.

| Adjustment order | Adjustment Item                         | FLAG | Purpose  | Replacing Parts         |                           |     |            | JIG/TOOLS  | SET UP  | How to Operate  |
|------------------|---|------|--|-------------------------|---------------------------|-----|------------|--|---|---|
|                  |   |      |  | MAIN P.C.B./F-ROM/VENUS | Lens part (include MOS U) | MIC | Flash Part |  |   |   |
| 1                | Optical Tilt Adjustment                 |      | Adjustment of MOS FPC installation angle to lens                                 | -                       | O                         | -   | -          |  | Please execute the adjustment by using optical tilt adjustment software "DSC_Tilt" for DMC-SZ7. The adjustment software "DSC_Tilt" is available at "TSN Website", therefore, access to "TSN Website" at "Support Information from NWBG/VDBG-AVC".   |   |
| 2                | Zoom Home Position and Microphone check | ZHP  | Zoom Home Position adjustment  | O                       | O                         | O   | -          | NONE   | NONE  | 1) Press Shutter Button (Do not apply any shock and vibration for the camera while adjusting)<br>2) Voice is uttered for 5 seconds into the microphone, waiting 5 seconds after pushing a shutter release. ※Comparatively high voice is ideal. (Standard: 1Khz)<br>3) After completed, the "OK" message appears.  |
| 3                | OIS sensor                              | OIS  | OIS sensor output level adjustment   | O                       | O                         | -   | -          | NONE   | NONE  | 1) Press Shutter Button (Do not apply any shock and vibration for the camera while adjusting)<br>2) After completed, the "OK" message appears.  |
| 4                | Backfocus / GYRO                        | BF   | To have the focus tracking curve be appropriate shape and GYRO sensor adjustment | O                       | O ※1                      | -   | -          | -COLLIMATOR (VFK1164TCM02 or VFK1164TCM03 or RFK20422)               | 1) Set the camera in front of collimator so that the distance between collimator and camera becomes about 4 cm as shown in Fig.A. [NOTE] Please note that "NG" might happen while auto adjusting.<br>- Do not put the black colored stuff at the back side of collimator near hunting chart to get some certain brightness.<br>- Make sure the hunting chart has no dust and dirty condition.<br>- Not connect the USB cable at this stage. | 1) A star chart changes into the state where it is reflected to the center. Press Shutter Button (Do not apply any shock and vibration for the camera while adjusting). (Green ● mark is displayed on LCD).<br>2) A star chart changes into the state where it is reflected to the center.<br>3) Press shutter button.<br>4) After completed, the "OK" message appears. |
| 5                | Venus Zoom                              | PZM  | Venus Zoom Inspection  | O                       | -                         | -   | -          | NONE   | NONE  | 1) Press Shutter Button (Do not apply any shock and vibration for the camera while adjusting)<br>2) After completed, the "OK" message appears.  |
| 6                | Monitor Linearity                       | MLN  | Monitor Linearity adjustment   | O                       | O                         | -   | -          | -LIGHT BOX (RFK20523 (VFK1164TDVLB))                                 | 1) Set the camera in front of LIGHT BOX so that the distance between Light box and camera becomes about 4 cm as shown in Fig.B. [NOTE] - Not connect the USB cable at this stage.   | 1) Press Shutter Button (Do not apply any shock and vibration for the camera while adjusting)<br>2) After completed, the "OK" message appears.  |
| 7                | Shutter                                 | SHT  | Shutter speed adjustment   | O                       | O                         | -   | -          | -LIGHT BOX (RFK20523 (VFK1164TDVLB))                                 | 1) Set the camera in front of LIGHT BOX so that the distance between Light box and camera becomes about 12 cm as shown in Fig.B. [NOTE] - Not connect the USB cable at this stage.  | 1) Press Shutter Button (Do not apply any shock and vibration for the camera while adjusting)<br>2) After completed, the "OK" message appears.  |
| 8                | ISO                                     | ISO  | ISO sensitivity adjustment   | O                       | O                         | -   | -          | -LIGHT BOX (RFK20523 (VFK1164TDVLB))<br>-ND FILTER (RFK20513(ND0.3)) | 1) Set the ND FILTER (RFK20513) to the LIGHT BOX. (The LIGHT BOX "VFK1164TDVLB" can be used if the front hood of VFK1164TDVLB is removed.)<br>2) Set the camera in front of LIGHT BOX so that the distance between ND FILTER and camera becomes about 9 cm as shown in Fig.C. [NOTE] - Not connect the USB cable at this stage.   | 1) Press Shutter Button (Do not apply any shock and vibration for the camera while adjusting)<br>2) After completed, the "OK" message appears.  |
| 9                | High brightness coloration              | LIN  | High brightness coloration adjustment  | O                       | O                         | -   | -          | -LIGHT BOX (RFK20523 (VFK1164TDVLB))<br>-TR CHART (RFK20443)         | 1) Set the camera in front of LIGHT BOX so that the distance between Light box and camera becomes about 9 cm as shown in Fig.C. [NOTE] - Not connect the USB cable at this stage.   | 1) Press Shutter Button (Do not apply any shock and vibration for the camera while adjusting)<br>2) After completed, the "OK" message appears.  |
| 10               | White Balance                           | WBL  | White balance adjustment under various color temperature                         | O                       | O                         | -   | -          | -LIGHT BOX (RFK20523 (VFK1164TDVLB))<br>-TR CHART (RFK20443)         | 1) Insert the TR chart into the slot of light box as shown in Fig.E.<br>2) Set the camera in front of LIGHT BOX so that the distance between Light box and camera becomes about 15 cm as shown in Fig.B. [NOTE] - Not connect the USB cable at this stage.  | 1) Press Shutter Button (Do not apply any shock and vibration for the camera while adjusting)<br>2) After completed, the "OK" message appears.  |
| 11               | MOS Missing Pixels (White)※2            | WKI  | Compensation of MOS Missing Pixels (White)                                       | O                       | O ※1                      | -   | -          | NONE   | NONE  | 1) Press Shutter Button (Do not apply any shock and vibration for the camera while adjusting)<br>2) After completed, the "OK" message appears.  |

| Adjustment order | Adjustment Item                                    | FLAG | Purpose   | Replacing Parts                         |     |            |   | JIG/TOOLS  | SET UP  | How to Operate  |
|------------------|--|------|---|---|-----|------------|---|--|---|---|
|                  |  |      |   | MAIN P.C.B<br>Lens part (include MOS U) | MIC | Flash Part |   |  |   |   |
| 12               | Flash adjustment                                   | STB  | Flash adjustment  | ○                                       | —   | —          | ○ | NONE   | NONE  | 1) Press Shutter Button<br>(Do not apply any shock and vibration for the camera while adjusting.)<br>2) Check that a flash shines. (It is different for every mode how many times it shines.)<br>※When a flash does not shine, there is a possibility that the flash unit is out of order.<br>3) Check a test result. ※Results of the tests are usually NG. (When a result is OK, it is the completion of an inspection.)<br>4) When a result is NG, rewrite STB flag to an 'f' adjustment using DIAS.<br><br>※STB is an item which checks shines operation of a flash automatically at a Manufacturing facility. For this reason, Except environment for exclusive use, a result will be NG, but it is no problem if shines operation can be checked visually. |
| 13               | Color reproduction inspection and Microphone check | COL  | Color reproduction inspection and Microphone check  | ○                                       | ○   | —          | — | NONE   | NONE  | 1) Press Shutter Button<br>(Do not apply any shock and vibration for the camera while adjusting.)<br>2) After completed, the "OK" message appears.  |
|                  |  | BK1  | Do not use "BK1" adjustment flag for this unit. Use "BK2" adjustment flag, instead.<br>(In case of most DSC models, the adjustment flag for MOS Missing Pixels is "BK1". But, in this model, "BK2" the adjustment flag for MOS Missing Pixels.) |   |     |            |   |  |   |   |
| 14               | MOS Missing Pixels (Black)※3                       | BK2  | Compensation of MOS Missing Pixels (Black)  | ○                                       | ○※1 | —          | — | *LIGHT BOX:<br>(RFKZ0523)<br>(VFK1164TDVLB)<br>*DIFFUSER<br>(RFKZ0591) | 1) Prepare the LIGHT BOX (RFKZ0523).<br>(The LIGHT BOX "VFK1164TDVLB" can be used if the front hood of VFK1164TDVLB is removed.)<br>2) Set the Diffuser (RFKZ0591) to the LIGHT BOX.<br>3) Set the camera in front of LIGHT BOX so that the distance between Diffuser and camera becomes about 4 cm as shown in Fig.D.<br>[NOTE]<br>- Do not use "BK1" adjustment flag for this unit. Use "BK2" adjustment flag, instead. | 1) Press Shutter Button after SET UP.<br>(Green ● mark is displayed on LCD)<br>2) Press Shutter Button.<br>(The 1st adjustment is executed, and then green ● mark is displayed on LCD).<br>3) Press Shutter Button.<br>(Green ● mark is displayed on LCD).<br>4) Press Shutter Button.<br>(The 2nd adjustment is executed, and then green ● mark is displayed on LCD).<br>5) Press Shutter Button.<br>(Green ● mark is displayed on LCD).<br>6) Press Shutter Button.<br>(The 3rd adjustment is executed, and then "OK" mark is displayed on LCD when the adjustment has been completed successfully.)  |
| 15               | OIS Act adjustment                                 | DAC  | OIS performance/Lens flare/ghost adjustment   | ○                                       | ○   | —          | — | NONE   | 1) Set the camera on plane.   | 1) Press Shutter Button<br>(Do not apply any shock and vibration for the camera while adjusting.)<br>2) After completed, the "OK" message appears.  |

- ※1: This adjustment must be performed not only replacing the MOS FPC unit, but also simply removing the MOS FPC unit.  
 ※2: The pixel that always lights while shaded is called a white wound.  
 ※3: The pixel that does not light while complete exposed is called a black wound.  
 \*This unit does not have the LCD adjustment of the camera (LCD flicker adjustment etc.).

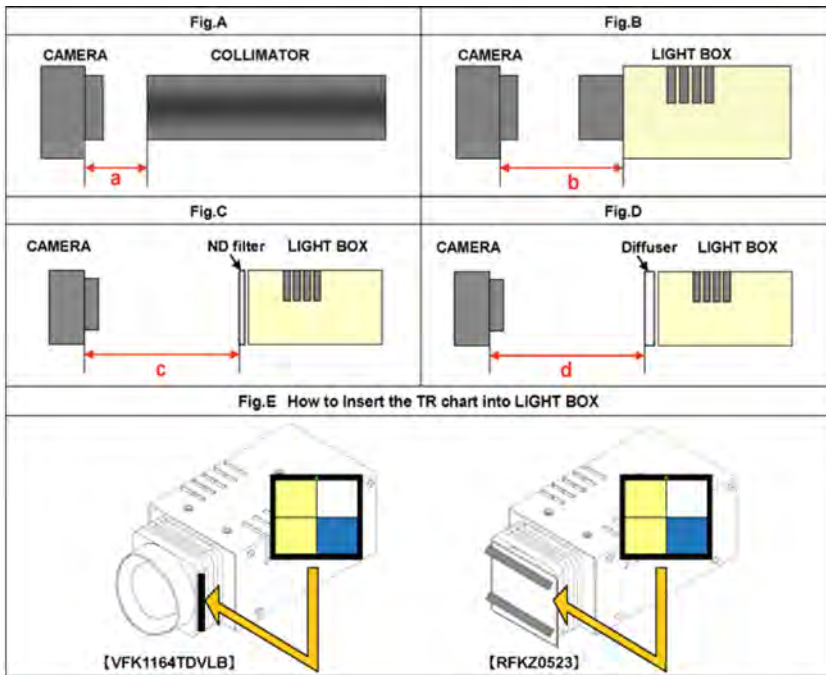

■ **IMPORTANT NOTICE** (After replacing the MAIN P.C.B.)  
 After replacing the MAIN P.C.B., make sure to perform the "INITIAL SETTINGS" first, then release the "INITIAL SETTINGS" in order to proceed the electrical adjustment.

**NOTE:**

- 1). If electrical adjustment or data re-writing is executed before "INITIAL SETTINGS", suffix code list is never displayed, and it cannot be chosen suitable suffix code.
- 2). Never remove the battery during initial setting in process.

## **9.4. After Adjustment**

### **9.4.1. Initial Setting**

Since the initial setting has been released to execute the built-in adjustment software, it should be set up again before shipping the camera to the customer.

Refer to the procedure described in “3.5.2. INITIAL SETTINGS” for details.

#### **[ IMPORTANT ]**

1. The initial setting should be done again after completing the alignment. Otherwise, the camera will not work properly.  
Therefore as a warning, the camera display a warning symbol “ ! ” on the LCD monitor every time the camera is turned off.
2. Confirm that status of all adjustment flag show “F”. Even if one of the adjustment flag shows “0”, initial setting programmed is never executed.

# 10 Maintenance

## 10.1. Cleaning Lens and LCD Panel

Do not touch the surface of lens and LCD Panel with your hand.

When cleaning the lens, use air-Blower to blow off the dust.

When cleaning the LCD Panel, dampen the lens cleaning paper with lens cleaner, and the gently wipe the its surface.

**Note:**

The Lens Cleaning KIT ; VFK1900BK (Only supplied as 10 set/Box) is available as Service Aid.



# 11.2. System Control Block Diagram

◆ SYSTEM CONTROL BLOCK DIAGRAM

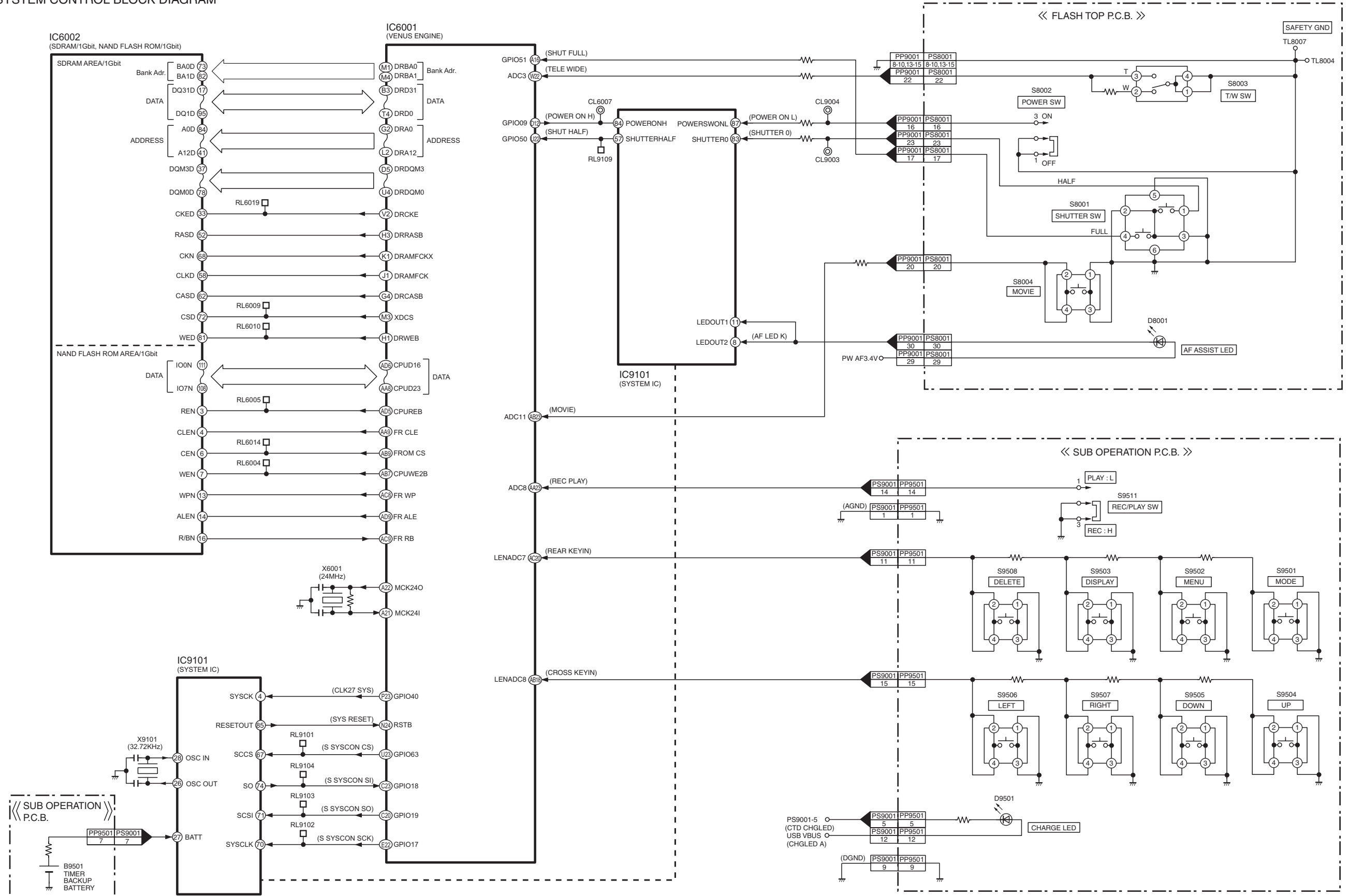

DMC-SZ7 SYSTEM CONTROL BLOCK DIAGRAM

# 11.3. Video/Audio Process Block Diagram

## VIDEO/AUDIO PROCESS BLOCK DIAGRAM

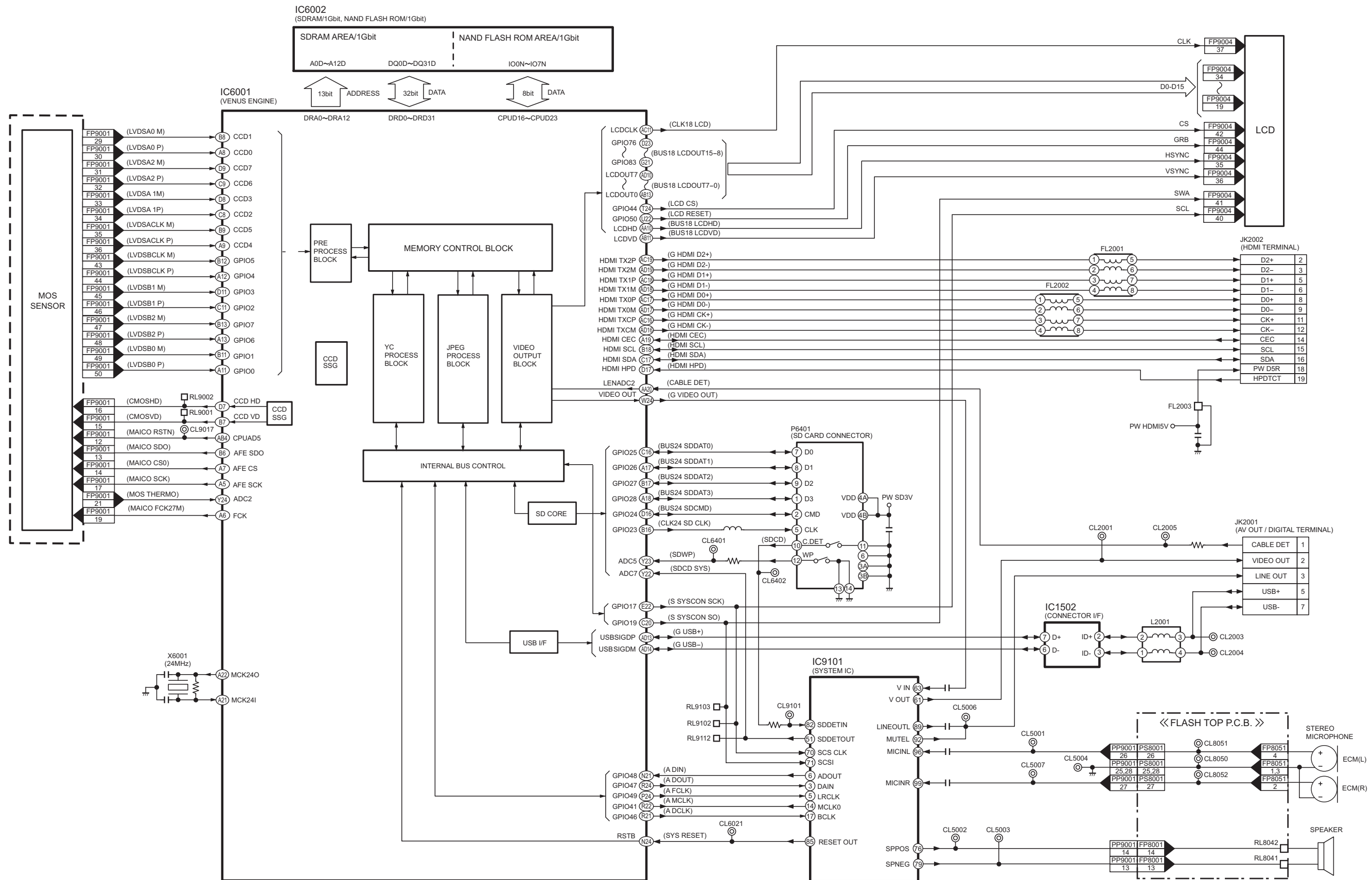

DMC-SZ7 VIDEO/AUDIO PROCESS BLOCK DIAGRAM

# 11.4. Lens Drive Block Diagram

LENS DRIVE BLOCK DIAGRAM

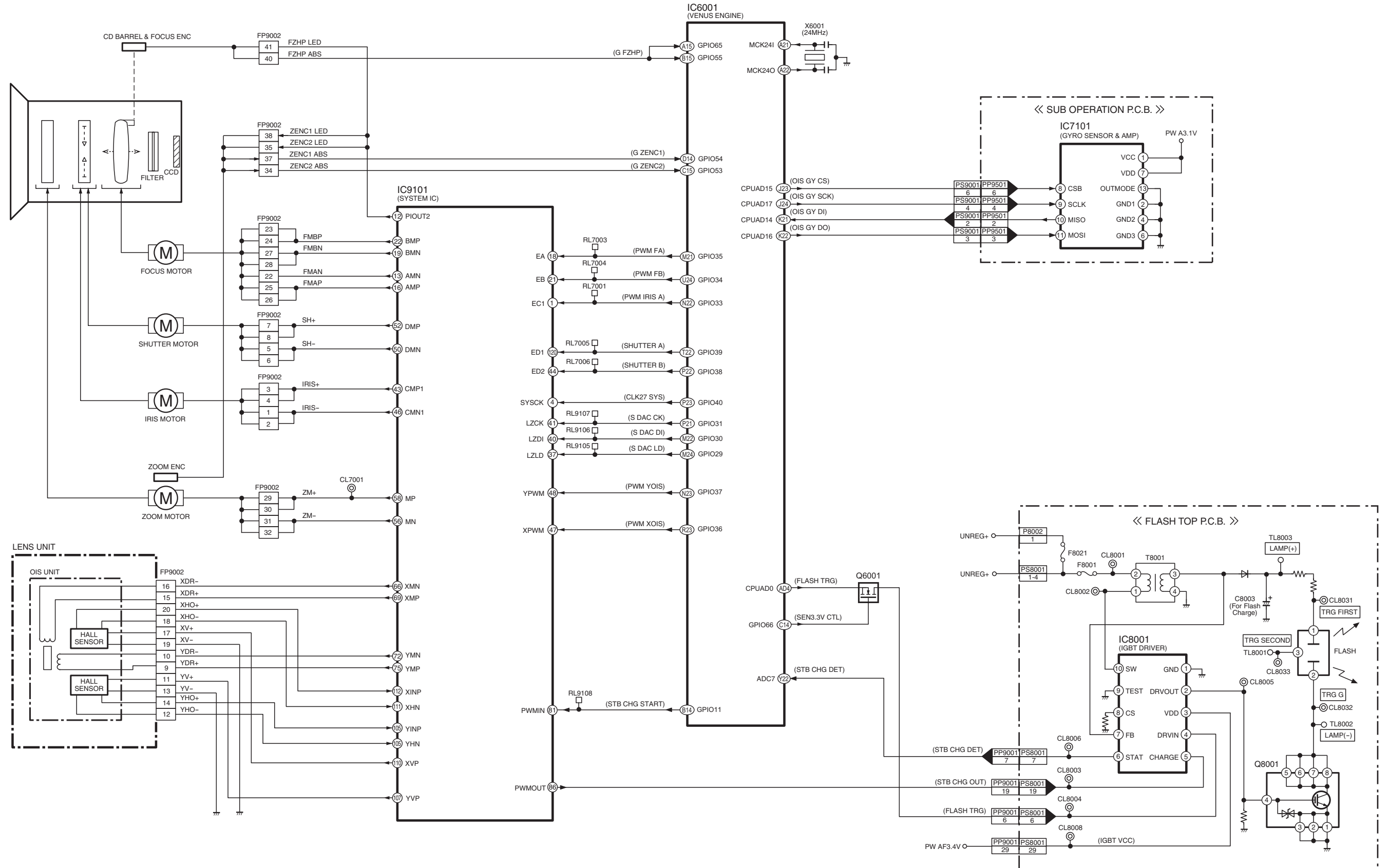

DMC-SZ7 LENS DRIVE BLOCK DIAGRAM

# 11.5. Power Block Diagram

POWER BLOCK DIAGRAM

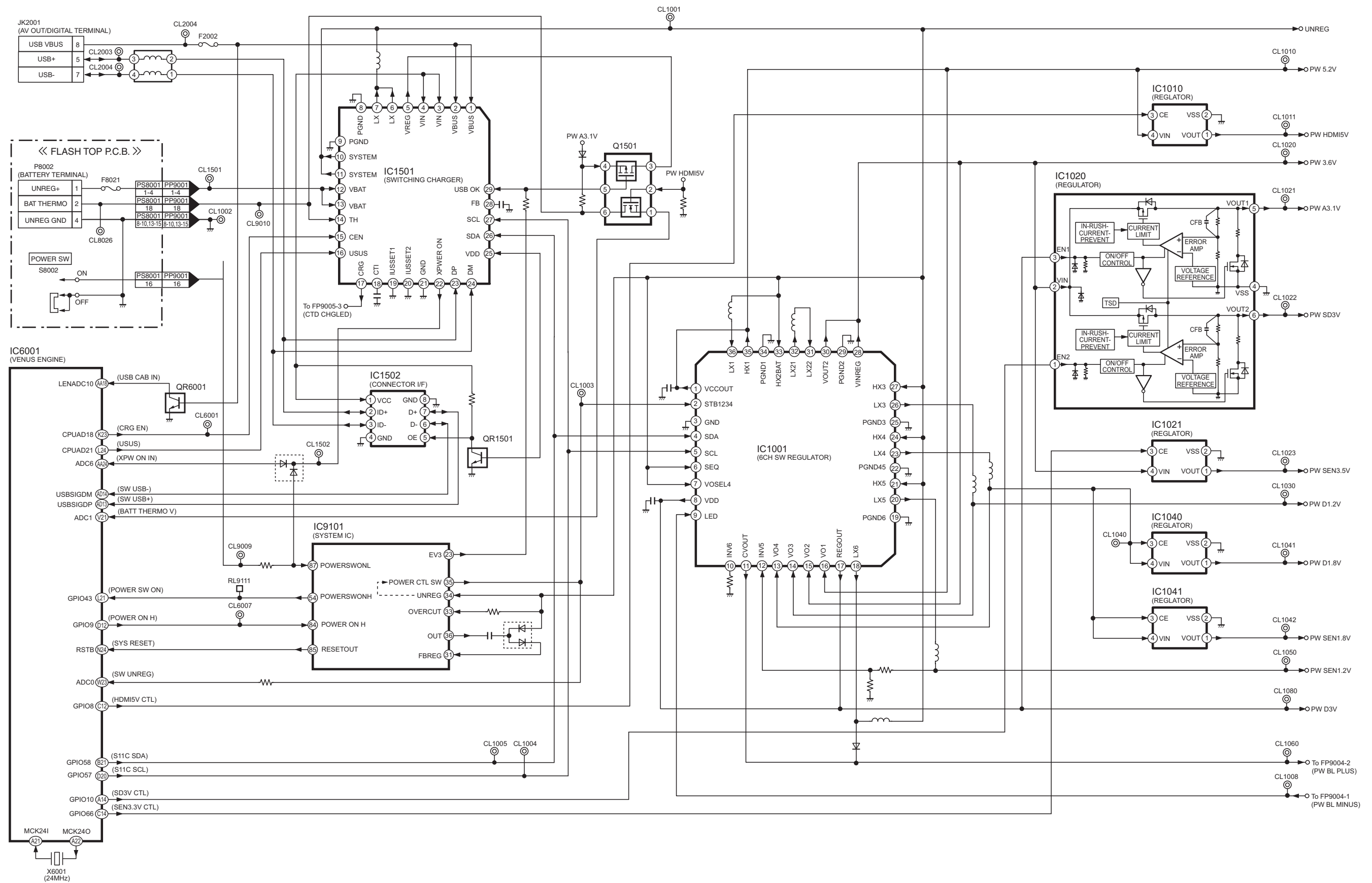

DMC-SZ7 POWER BLOCK DIAGRAM

# 12 Wiring Connection Diagram

## 12.1. Interconnection Diagram

◆ INTERCONNECTION DIAGRAM

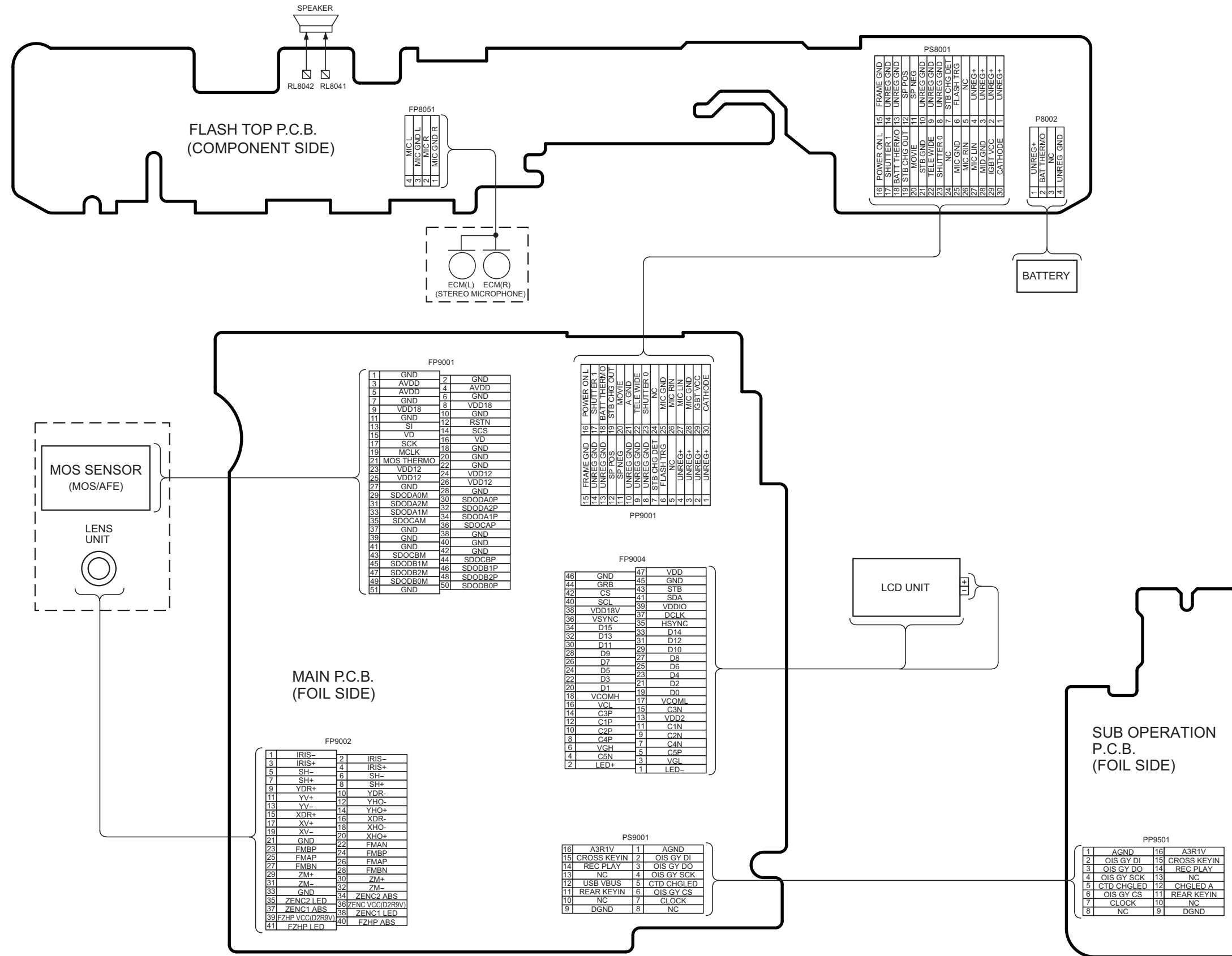

### IMPORTANT SAFETY NOTICE:

COMPONENTS IDENTIFIED WITH THE MARK  HAVE THE SPECIAL CHARACTERISTICS FOR SAFETY. WHEN REPLACING ANY OF THESE COMPONENTS USE ONLY THE SAME TYPE.

1. Although reference number of the parts is indicated on the P.C.B. drawing and/or schematic diagrams, it is NOT mounted on the P.C.B. when it is displayed with "\$" mark.
2. It is only the "Test Round" and no terminal (Pin) is available on the P.C.B. when the TP (Test Point) indicated as "●" mark.
3. Use the parts number indicated on the Replacement Parts List .
4. Indication on Schematic diagrams:

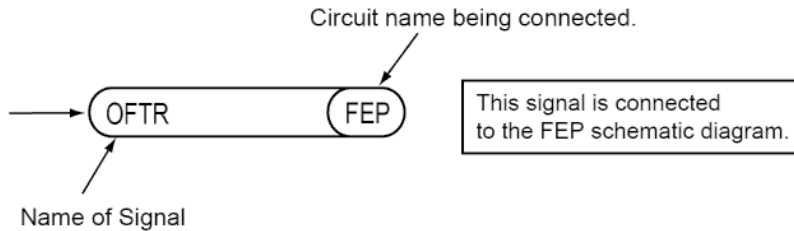

5. It might be taking time for display and/or access of the Schematic Diagrams & P. C. B. having the heavy data volume.

- Note:
1. \* Be sure to make your orders of replacement parts according to this list.
  2. **IMPORTANT SAFETY NOTICE**  
Components identified with the mark  $\Delta$  have the special characteristics for safety.  
When replacing any of these components, use only the same type.
  3. Unless otherwise specified,  
All resistors are in OHMS, K=1,000 OHMS. All capacitors are in MICRO-FARADS (uf), P=uuF.
  4. The marking (RTL) indicates the retention time is limited for this item. After the discontinuation of this assembly in production, it will no longer be available.
  5. Supply of CD-ROM, in accordance with license protection, is allowable as replacement parts only for customers who accidentally damaged or lost their own.

**E.S.D. standards for Electrostatically Sensitive Devices, refer to PREVENTION OF ELECTROSTATIC DISCHARGE (ESD) TO ELECTROSTATICALLY SENSITIVE (ES) DEVICES section.**

**Definition of Parts supplier:**

1. Parts marked with [ENERGY] in the remarks column are supplied from Panasonic Corporation Energy Company.
2. Parts marked with [SPC] in the remarks column are supplied from AVC-CSC-SPC. Others are supplied from PAVCX.

Model No. : DMC-SZ7 Power (P) (Main P.C.B.)

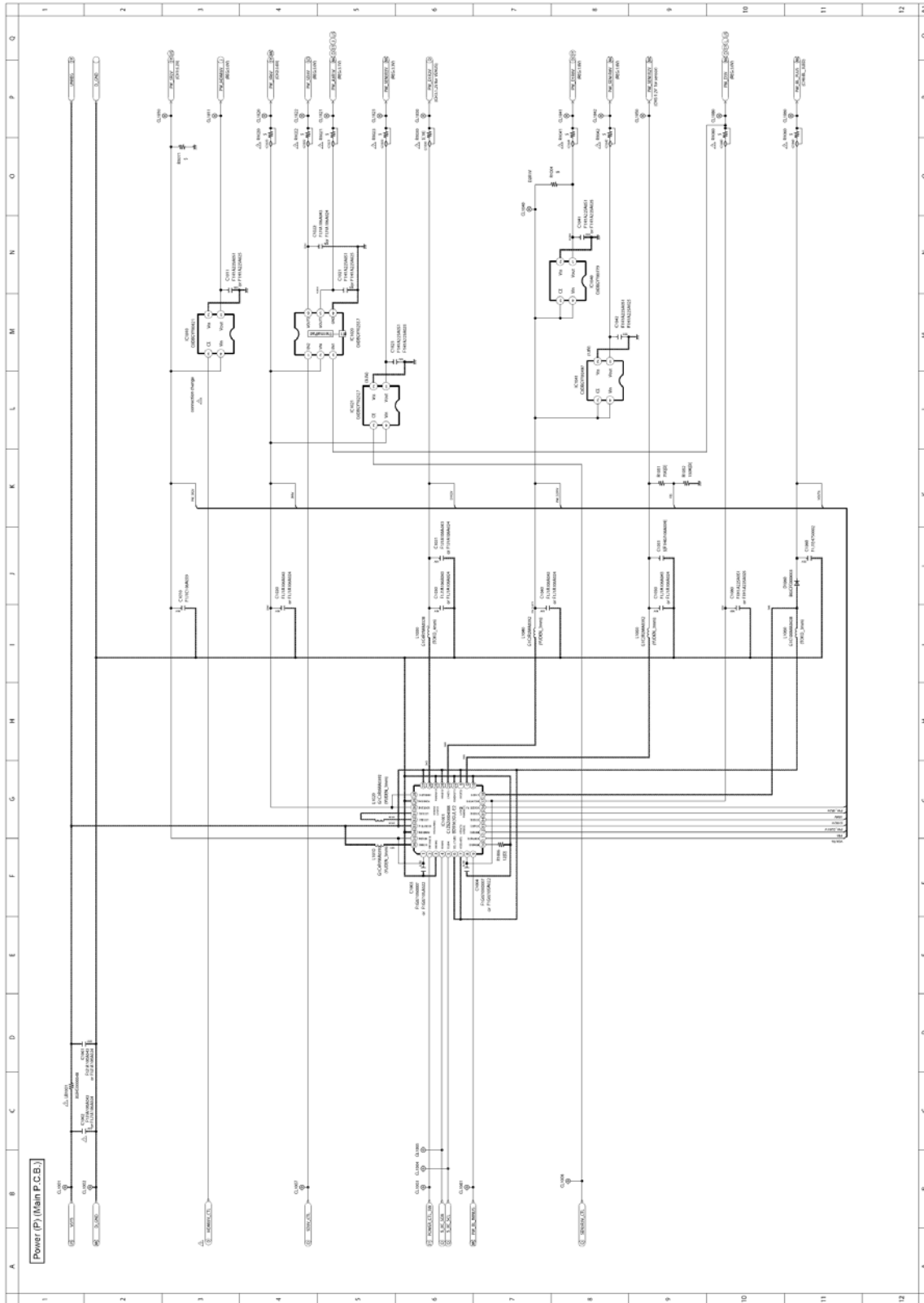

Model No. : DMC-SZ7 USB (U) (Main P.C.B.)

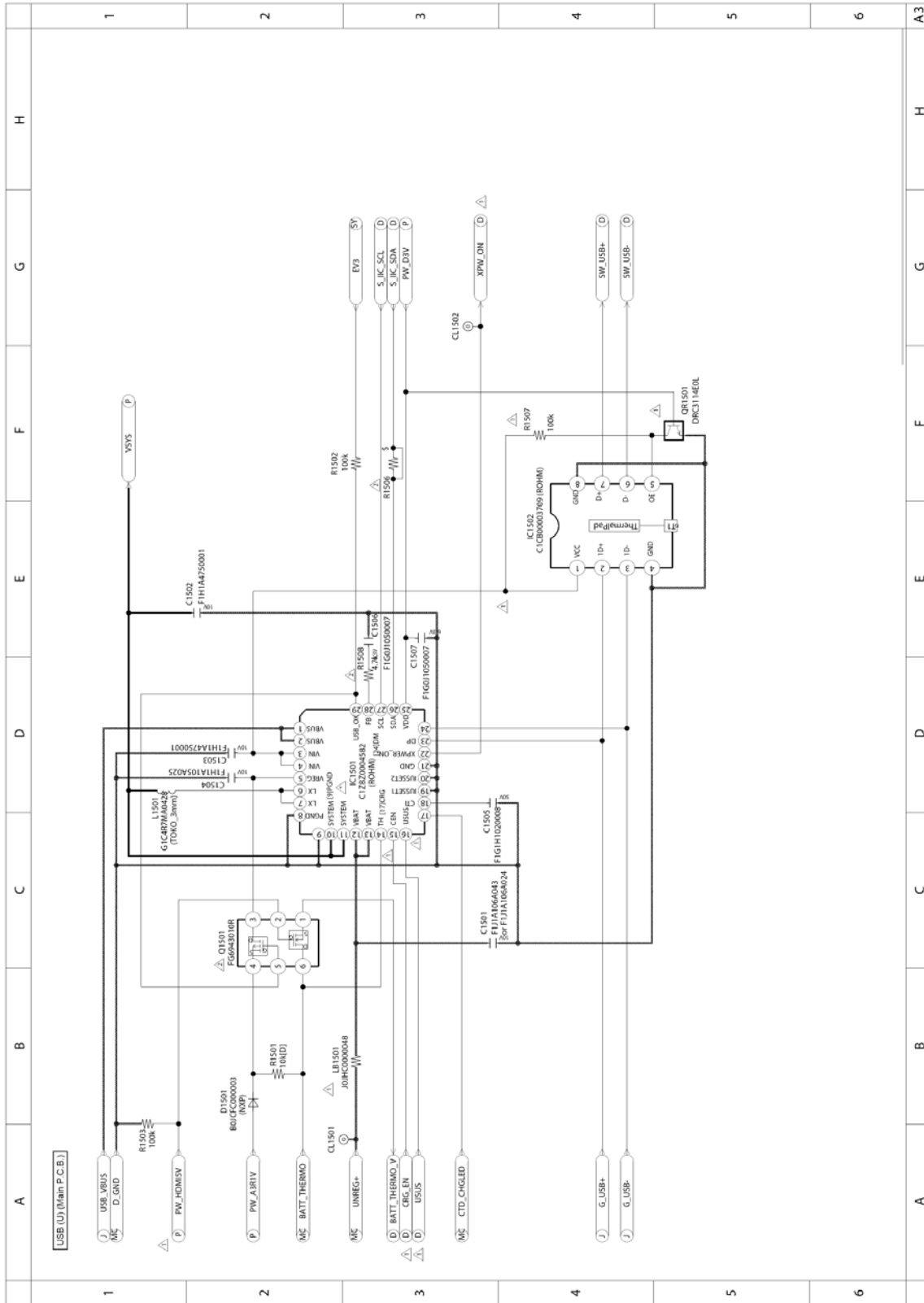

# Model No. : DMC-SZ7 Jack (J) (Main P.C.B.)

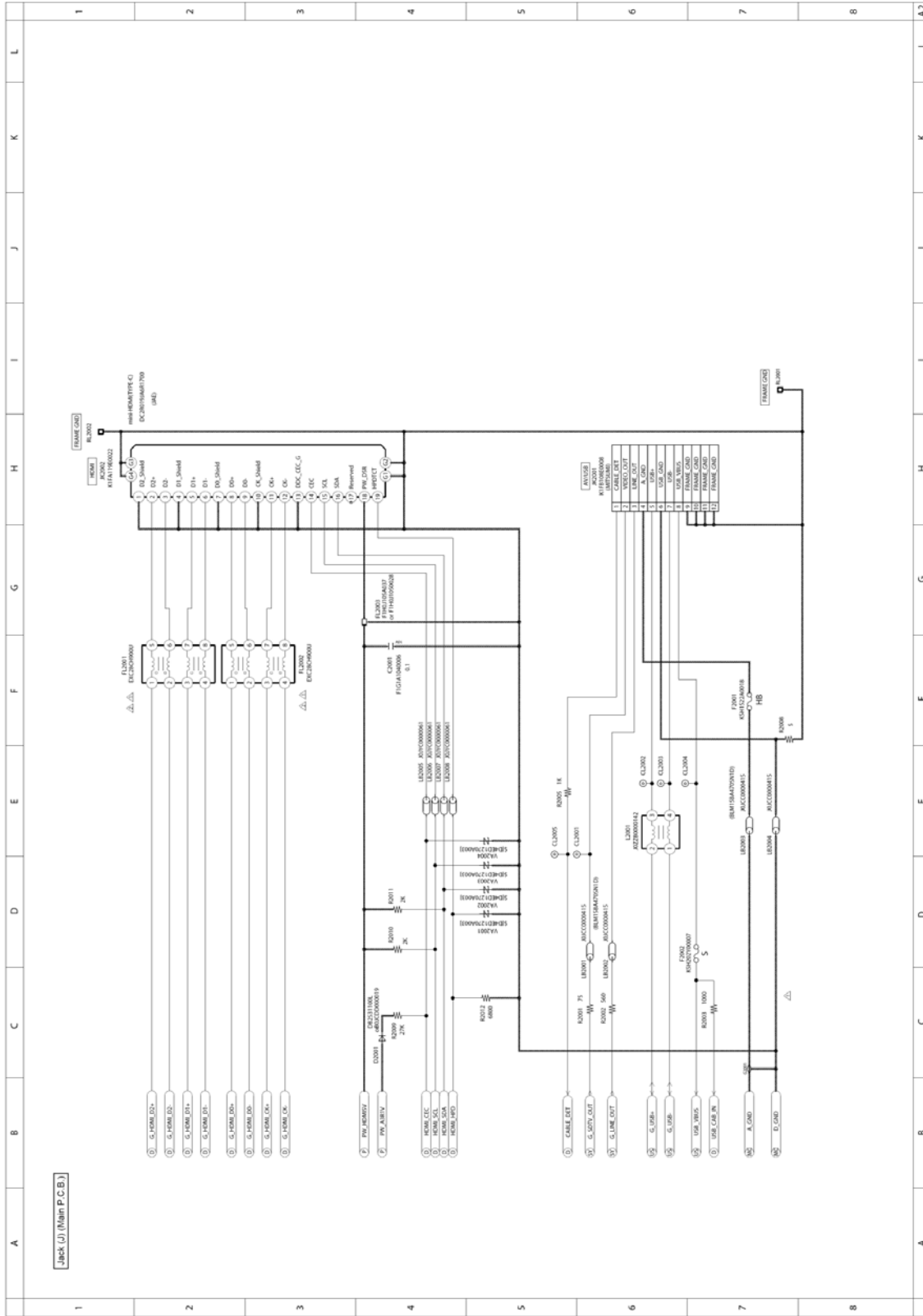

| A | B  | C  | D | E | F  |
|---|--|--|---|---|----|
| 1 | C-4001 F1G0J1050007<br>C-4002 F1G0J1050007<br>C-4003 F1H1A105A025<br>C-4004 F1H1A105A025<br>C-4005 F1H1A105A025<br>C-4006 F1H1A105A025<br>C-4007 F1H1A105A025<br>C-4008 F1G0J1050007<br>C-4009 F1G0J1050007<br>C-4010 F1H1C105A097 | PW_D3V (MC)<br>VDD_18V (MC)<br>VCOMH (MC)<br>VCOML (MC)<br>VCL (MC)<br>C3N (MC)<br>C3P (MC)<br>VDD2 (MC)<br>C1P (MC)<br>C1N (MC)<br>C2P (MC)<br>C2N (MC)<br>C4P (MC) |   |   | 1  |
| 2 | C-4011 F1H1E105A144 or F1H1E105A116<br>C-4012 F1H1C105A097<br>C-4013 F1H1C105A097  | C4N (MC)<br>VGH (MC)<br>C5P (MC)<br>C5N (MC)<br>VGL (MC)   |   |   | 2  |
| 3 |  |  |   |   | 3  |
| 4 |  |  |   |   | 4  |
| A | A  | B  | C | D | E  |
|   |  |  |   |   | F  |
|   |  |  |   |   | A4 |

[LCD (L) (Main P.C.B.)]

777

Model No. : DMC-SZ7 Digital (D) (Main P.C.B.)

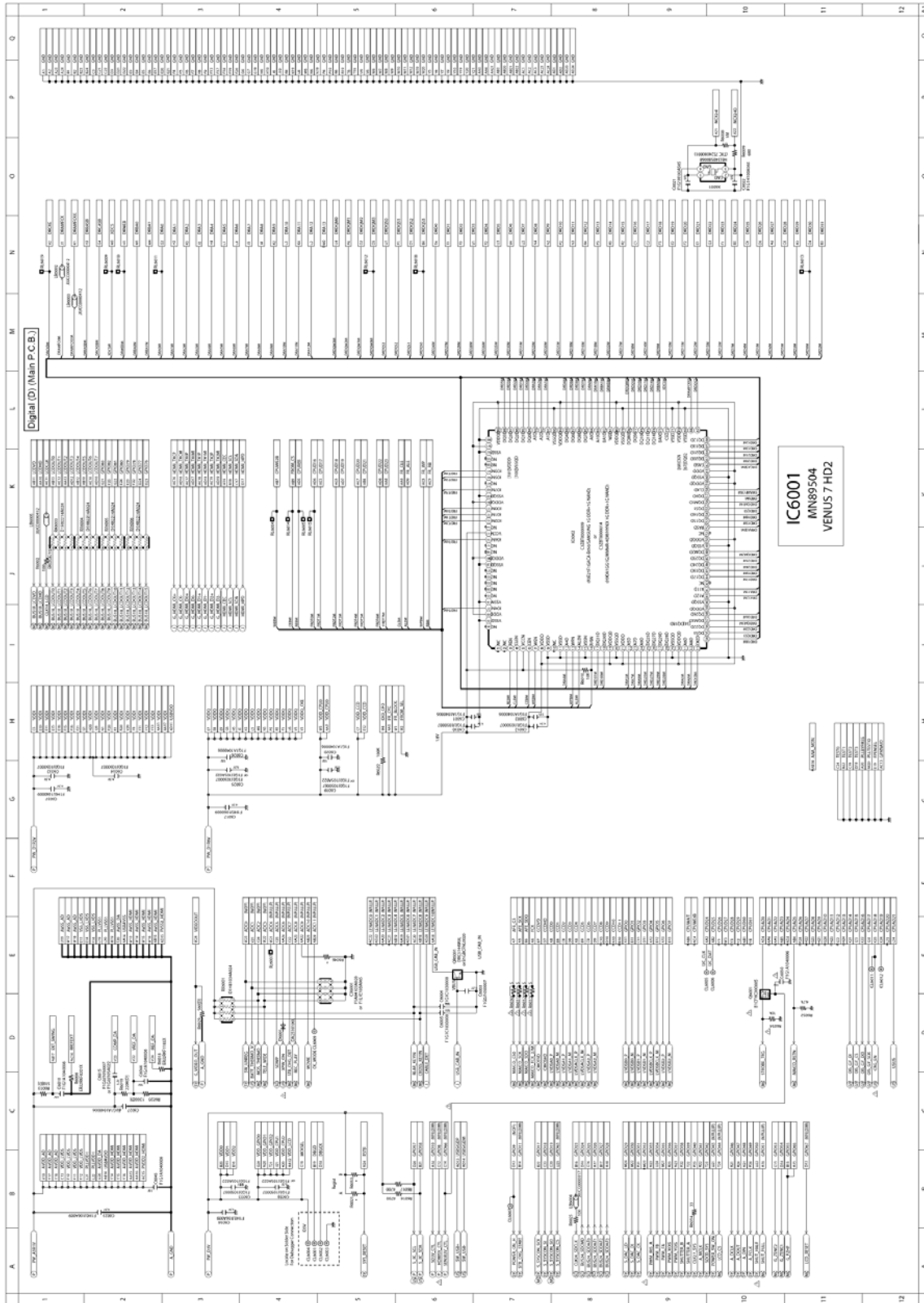

Model No. : DMC-SZ7 SD Card (SD) (Main P.C.B.)

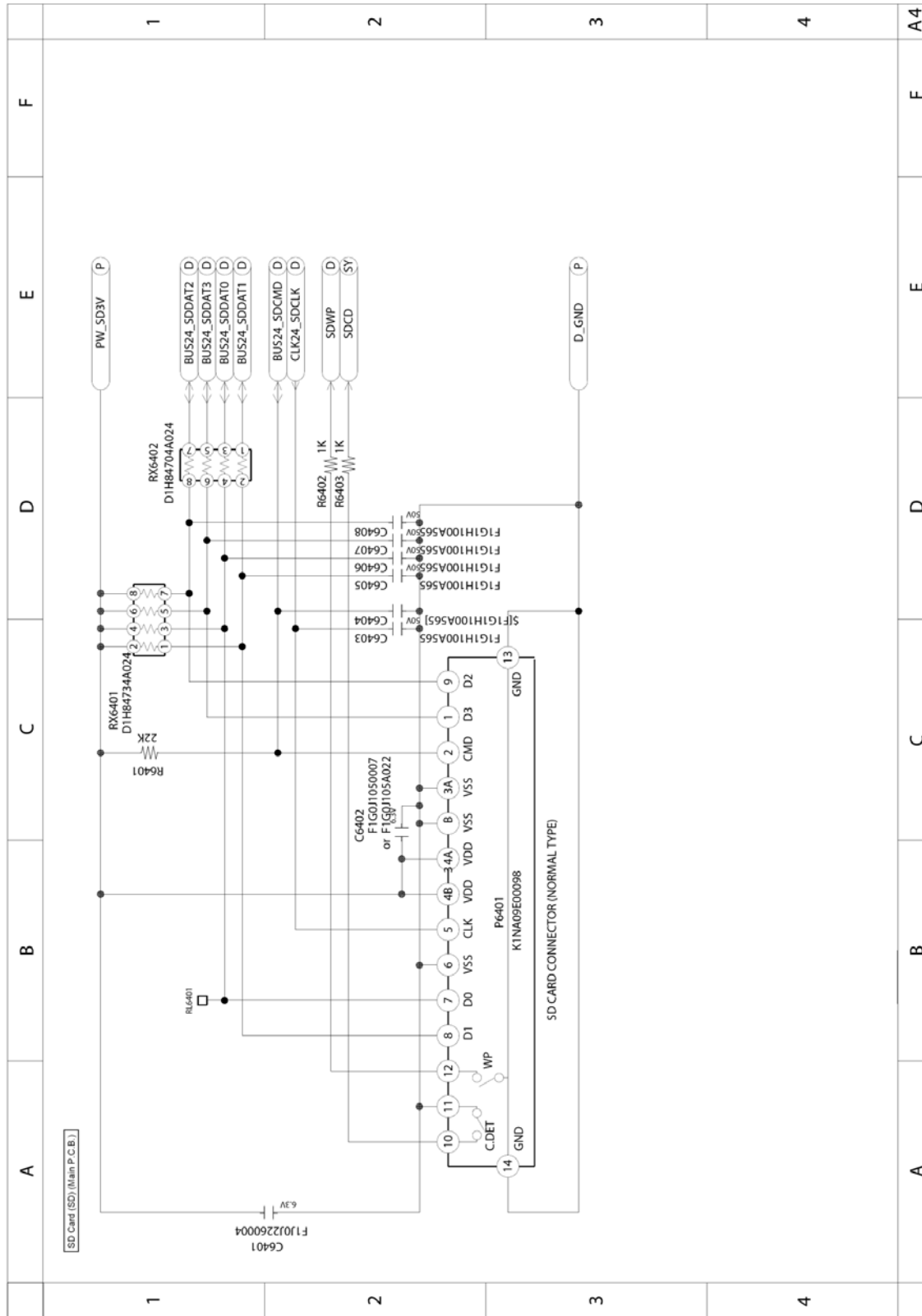





# Model No. : DMC-SZ7 Sub Operation (R) (Sub Operation P.C.B.)

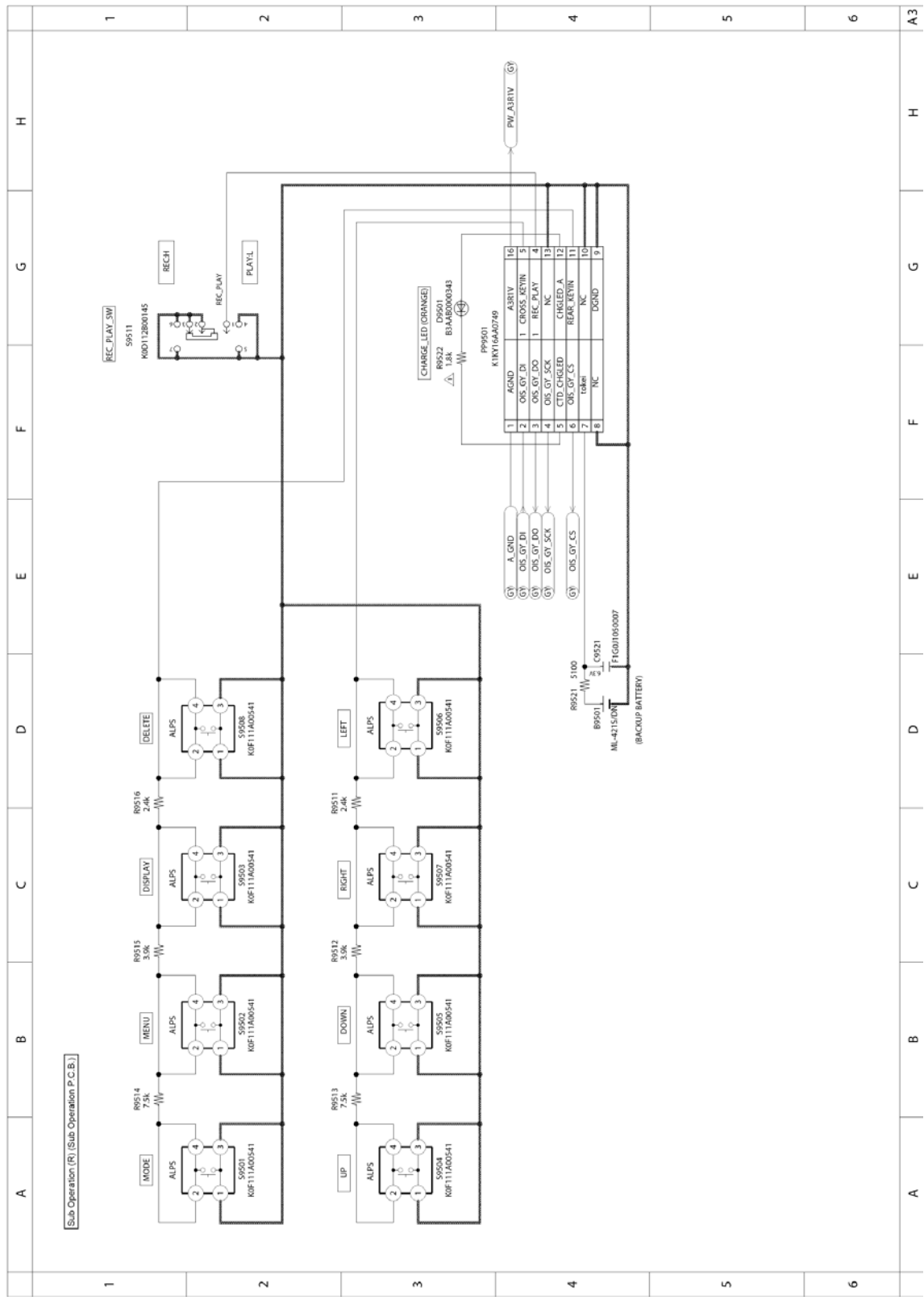

Model No. : DMC-SZ7 Gyro (GY) (Sub Operation P.C.B.)

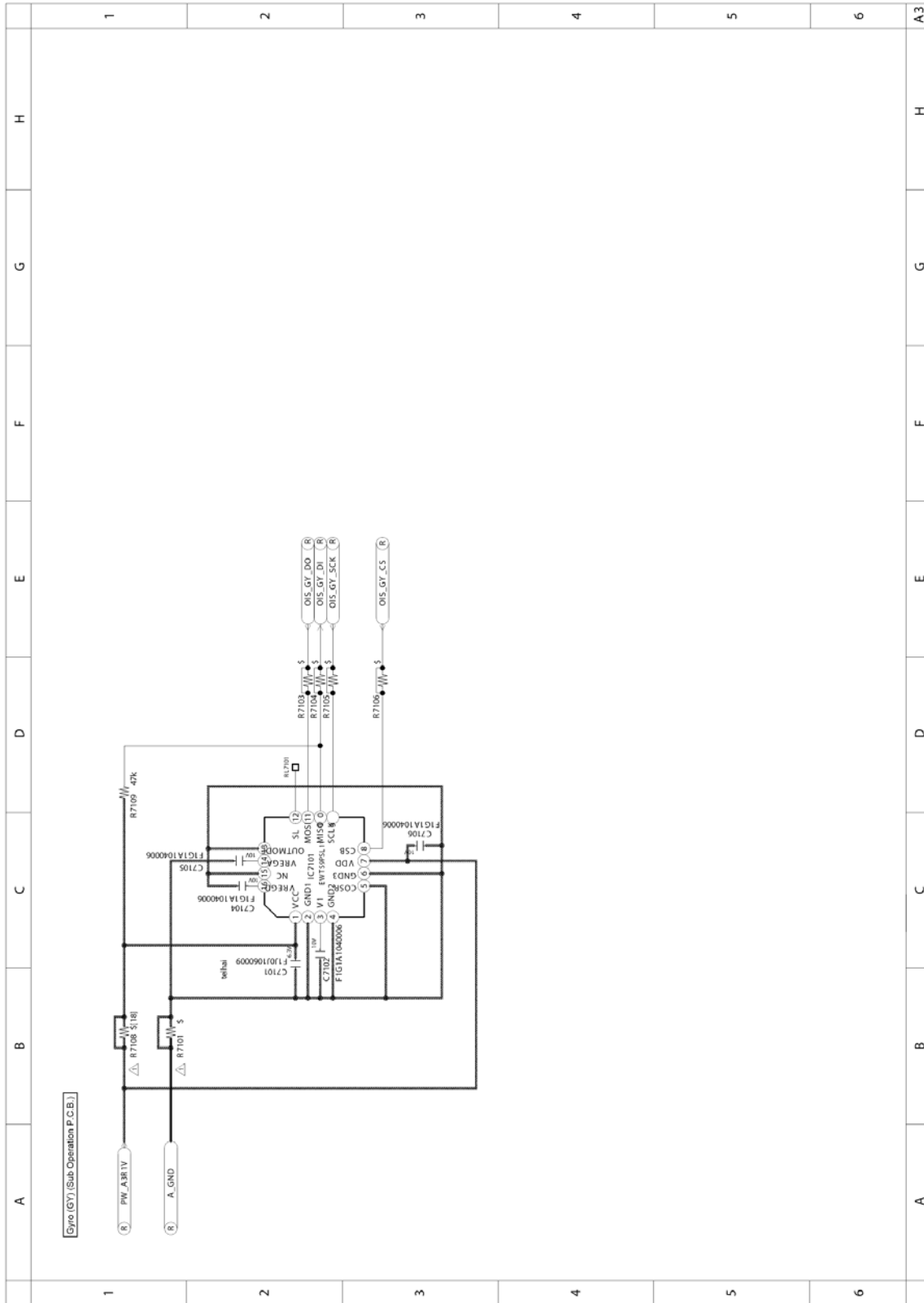

# Model No. : DMC-SZ7 Flash Top (Flash Top P.C.B.)

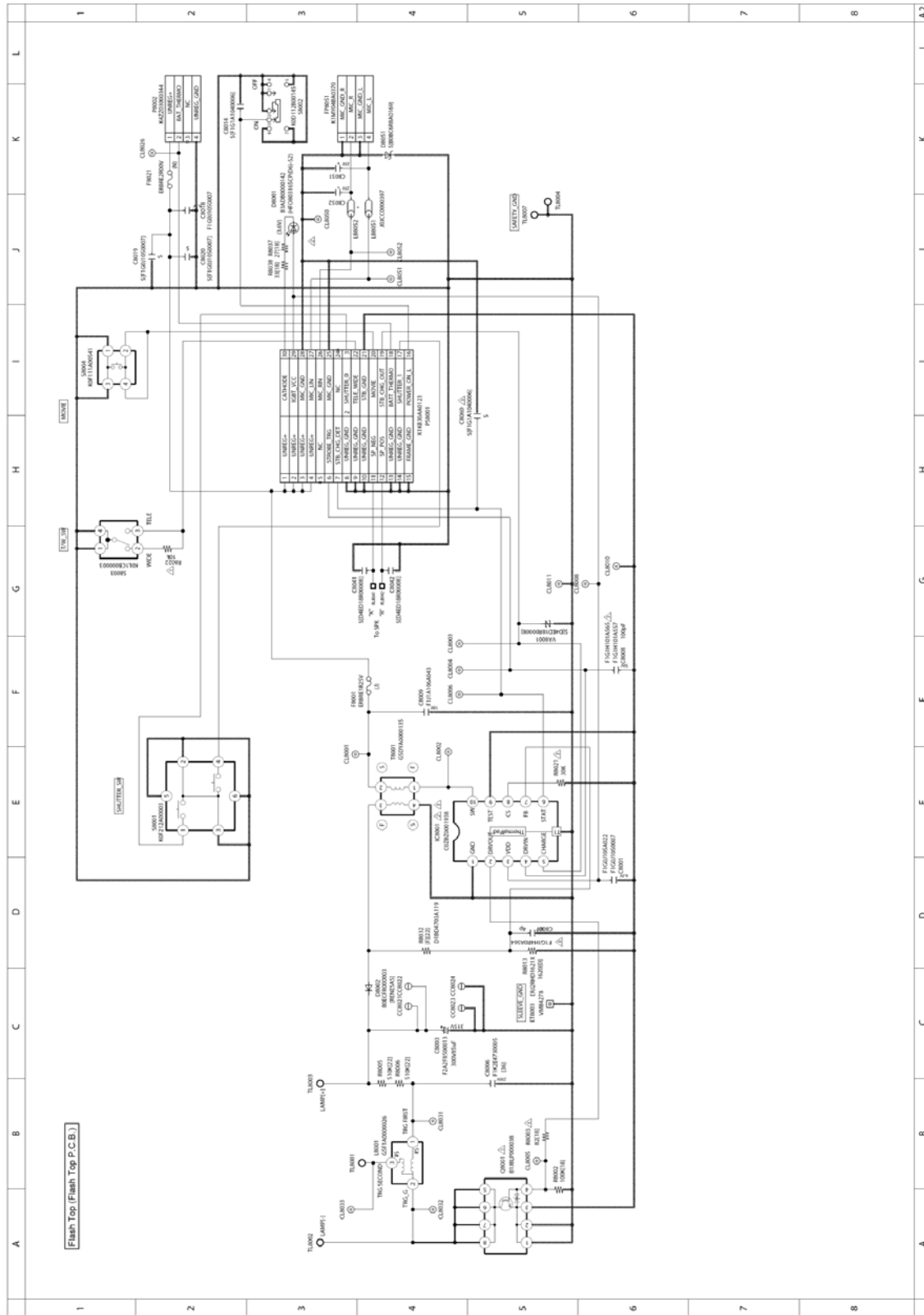

Model No. : DMC-SZ7 MOS (MOS P.C.B.)

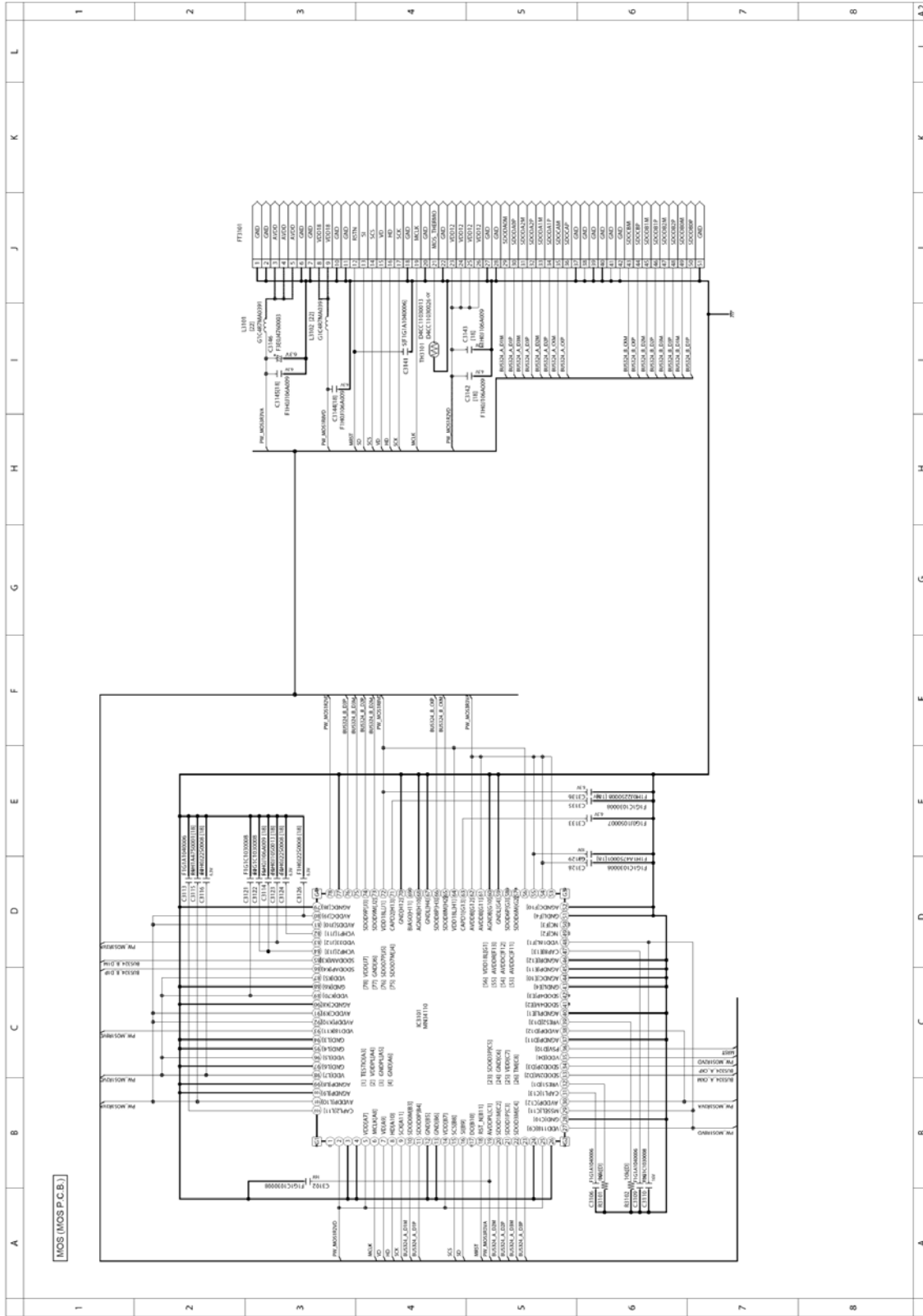

Model No. : DMC-SZ7 Lens Flex (Lens Flex P.C.B.)

Lens Flex (Lens Flex P.C.B.)

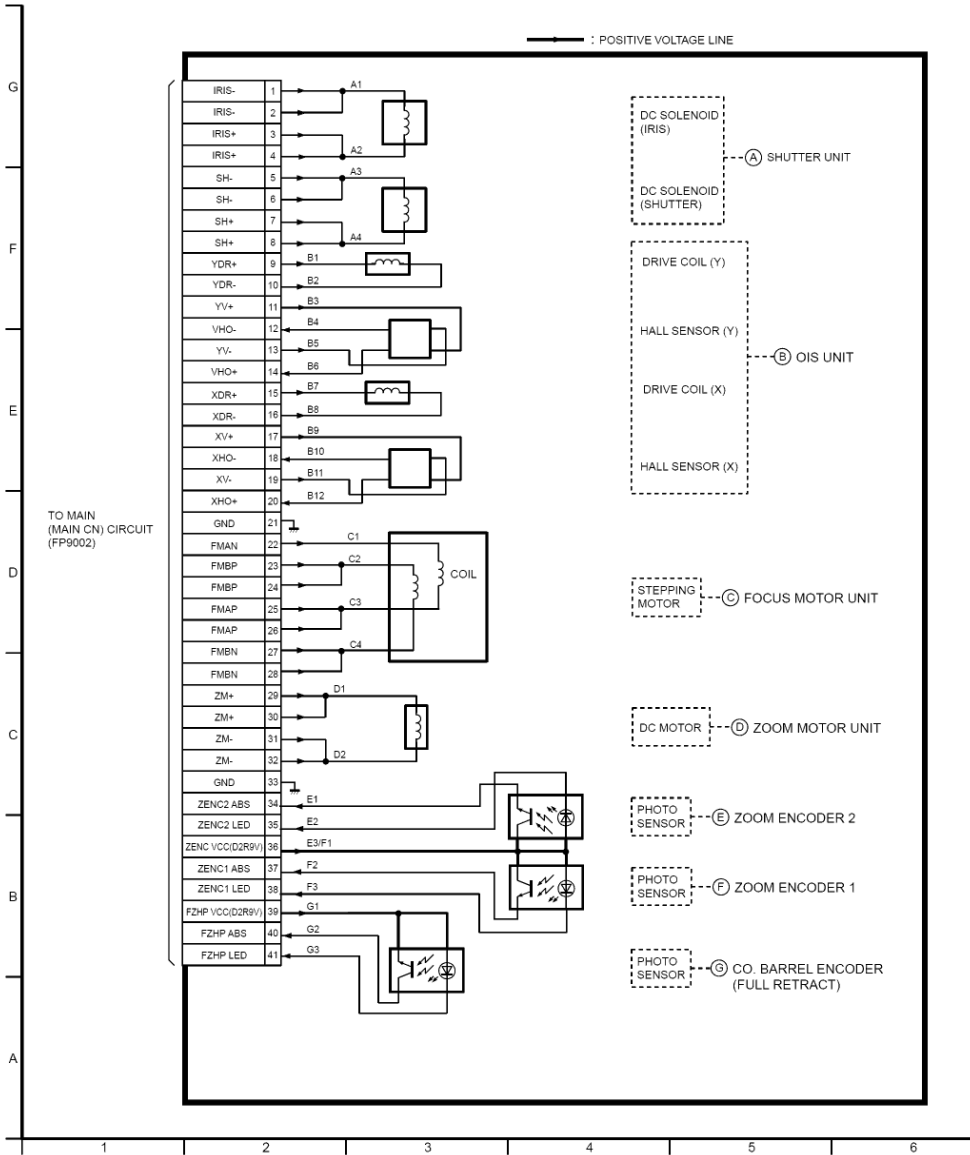



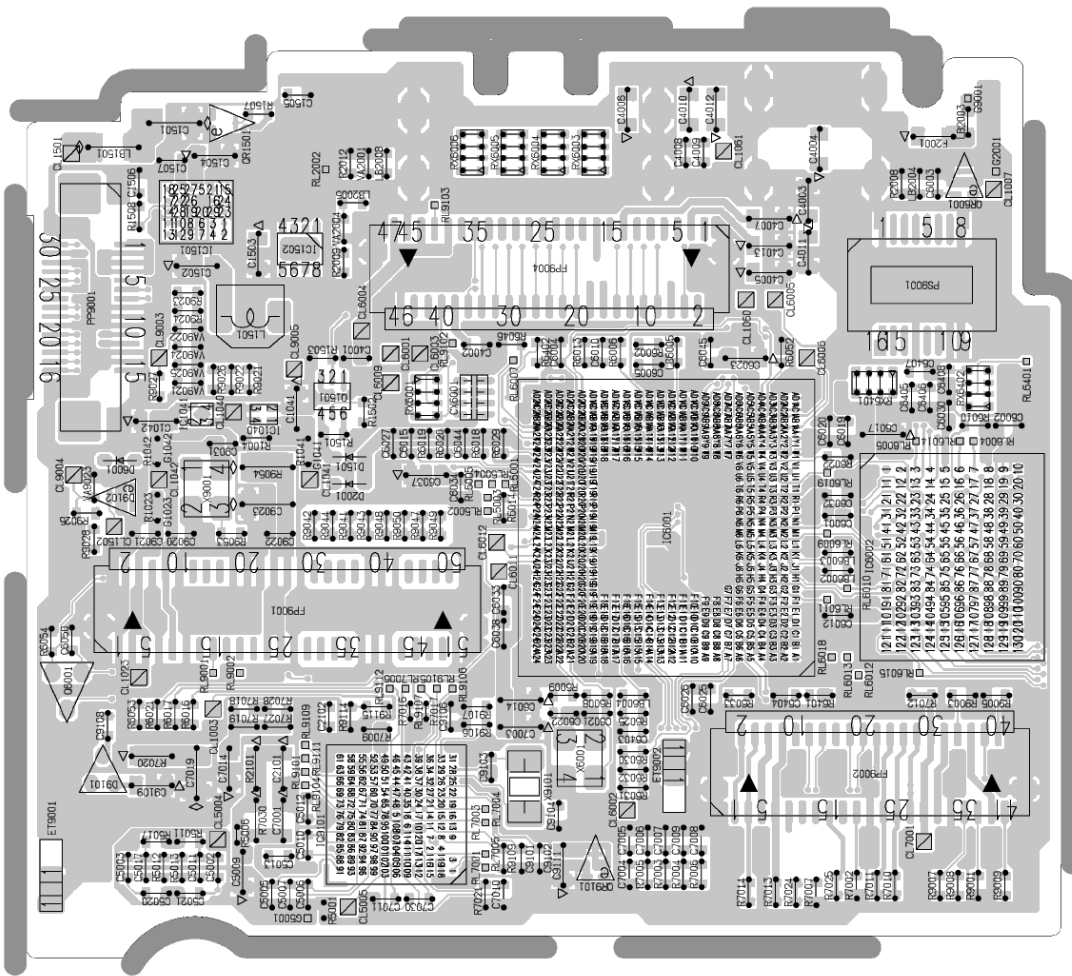

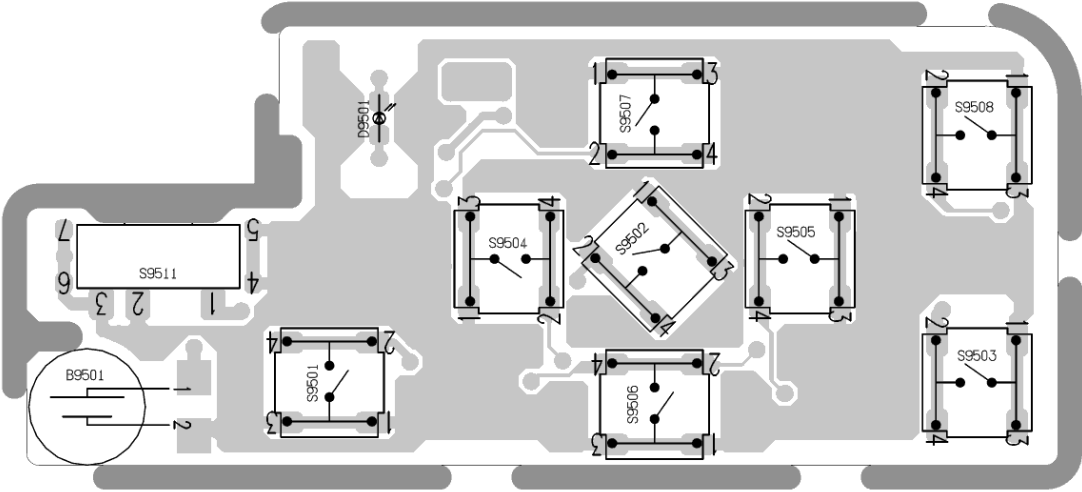

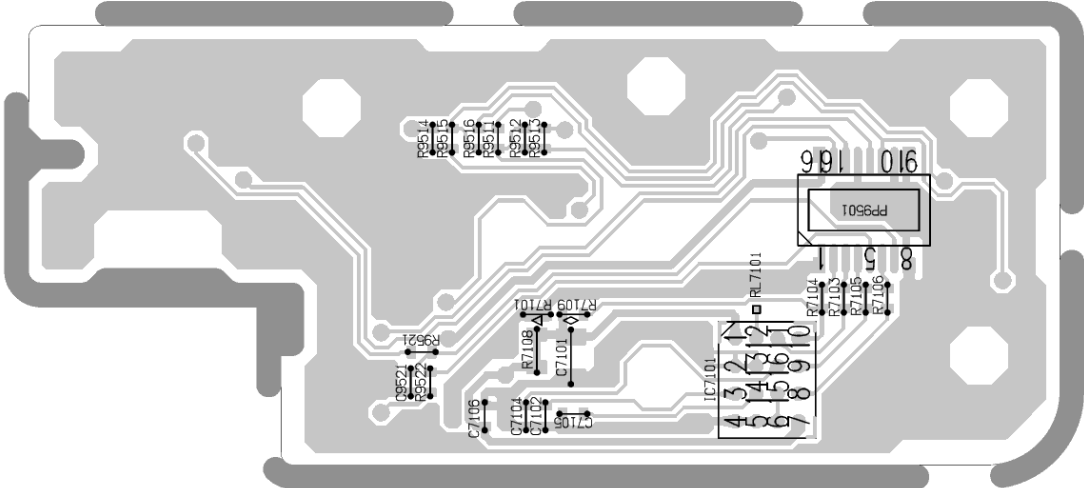



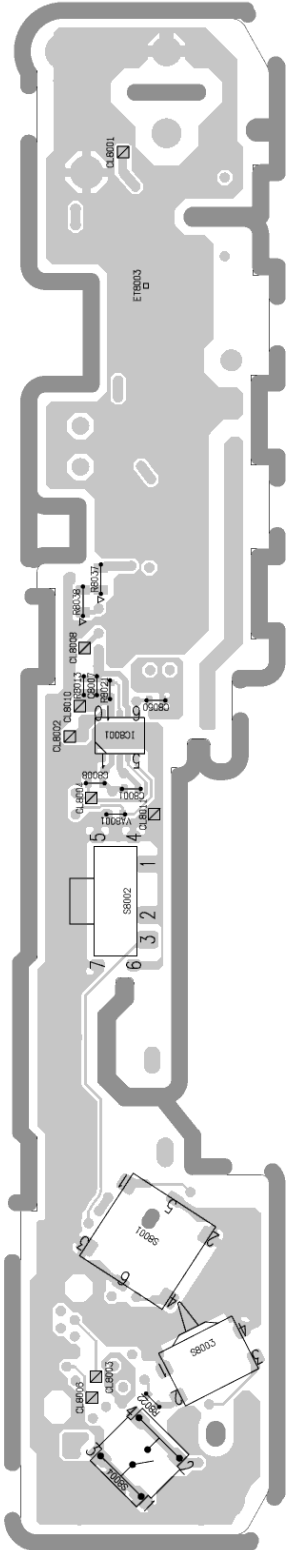

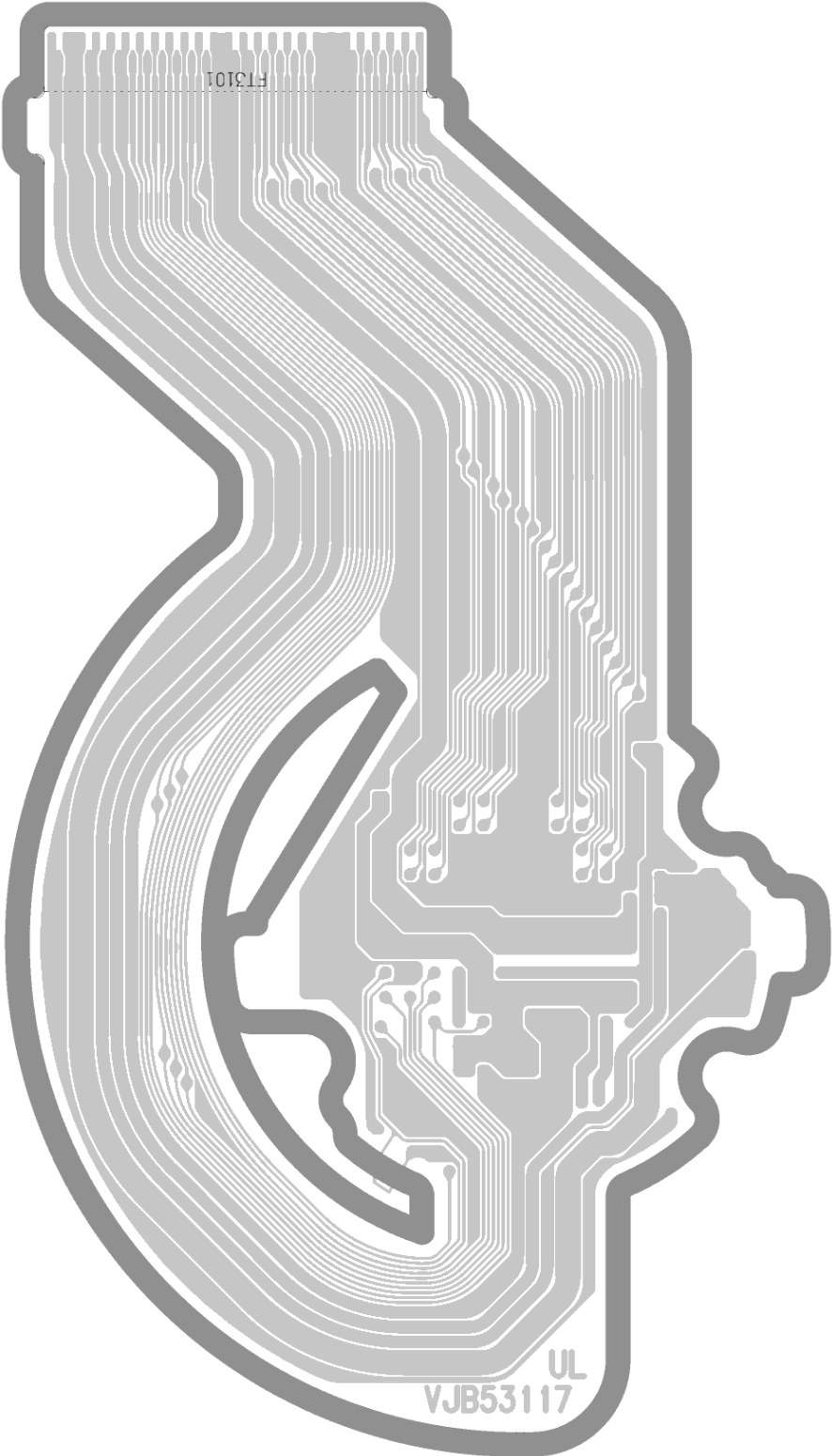

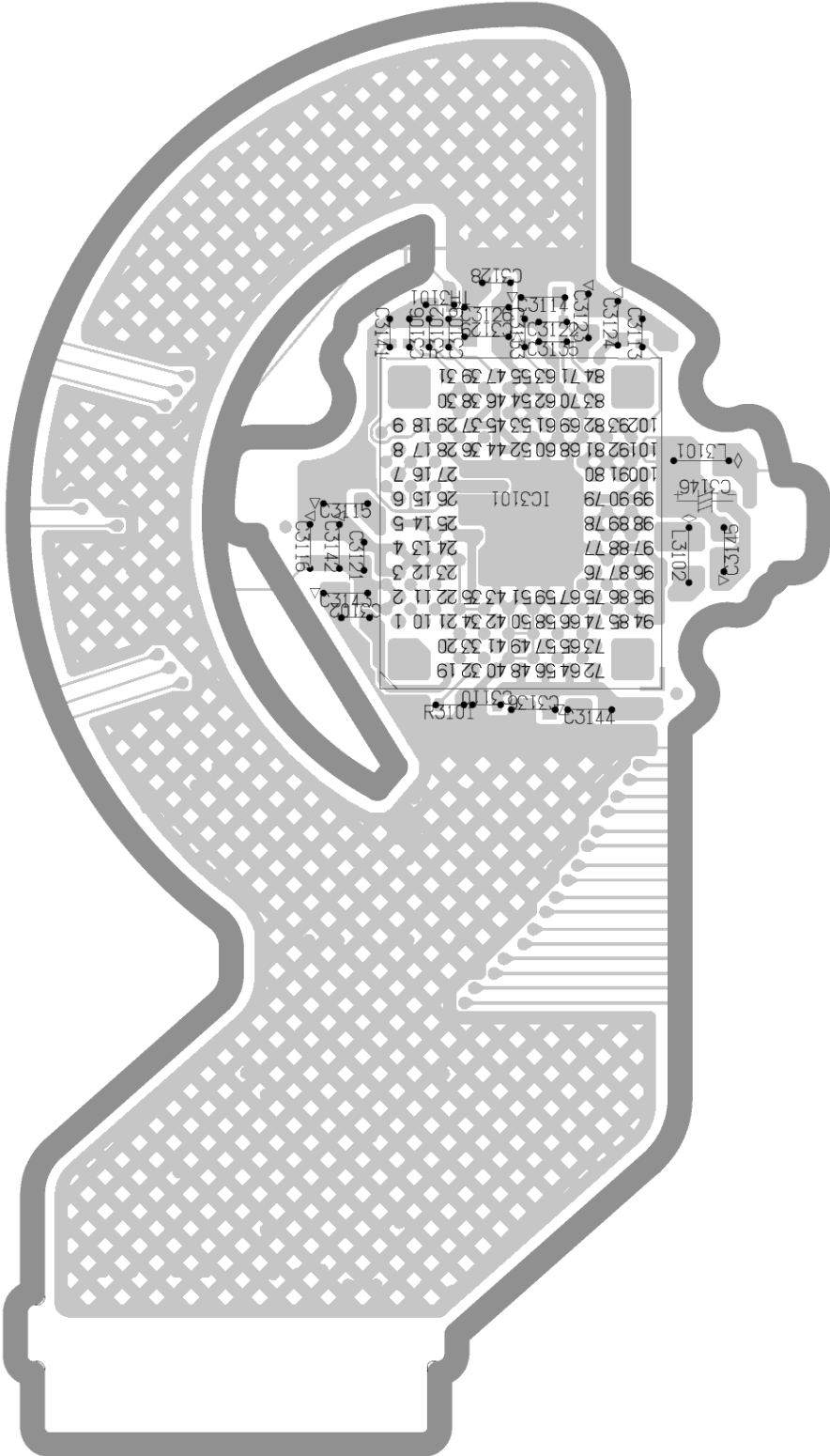

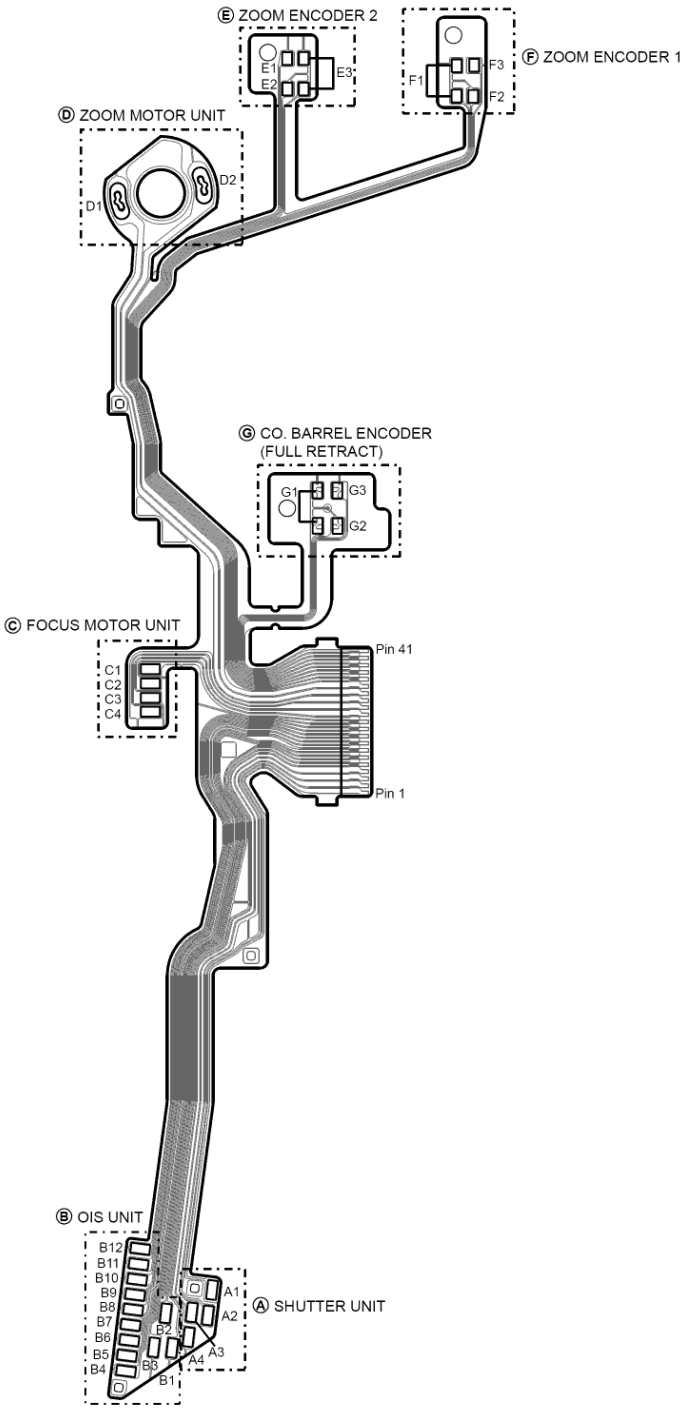





**Model No. : DMC-SZ7 Parts List**

| Safety | Ref. No. | Part No.     | Part Name & Description   | Q'ty | Remarks |
|--------|----------|--------------|---------------------------|------|---------|
|        | C1001    | FLJ1A106A024 | C.CAPACITOR CH 10V 10U    | 1    |         |
|        | C1002    | FLJ1A106A024 | C.CAPACITOR CH 10V 10U    | 1    |         |
|        | C1003    | FLG0J1050007 | C.CAPACITOR CH 6.3V 1U    | 1    |         |
|        | C1004    | FLG0J1050007 | C.CAPACITOR CH 6.3V 1U    | 1    |         |
|        | C1010    | FLJ1C106A059 | C.CAPACITOR CH 16V 10U    | 1    |         |
|        | C1011    | FLH1A225A051 | C.CAPACITOR CH 10V 2.2U   | 1    |         |
|        | C1020    | FLJ1A106A024 | C.CAPACITOR CH 10V 10U    | 1    |         |
|        | C1021    | FLH1A225A051 | C.CAPACITOR CH 10V 2.2U   | 1    |         |
|        | C1022    | FLJ1A106A043 | C.CAPACITOR CH 10V 10U    | 1    |         |
|        | C1023    | FLH1A225A051 | C.CAPACITOR CH 10V 2.2U   | 1    |         |
|        | C1030    | FLJ1A106A043 | C.CAPACITOR CH 10V 10U    | 1    |         |
|        | C1031    | FLJ1A106A043 | C.CAPACITOR CH 10V 10U    | 1    |         |
|        | C1040    | FLJ1A106A043 | C.CAPACITOR CH 10V 10U    | 1    |         |
|        | C1041    | FLH1A225A051 | C.CAPACITOR CH 10V 2.2U   | 1    |         |
|        | C1042    | FLH1A225A051 | C.CAPACITOR CH 10V 2.2U   | 1    |         |
|        | C1050    | FLJ1A106A043 | C.CAPACITOR CH 10V 10U    | 1    |         |
|        | C1060    | FLJ1E4750002 | C.CAPACITOR CH 25V 4.7U   | 1    |         |
|        | C1080    | FLH1A225A051 | C.CAPACITOR CH 10V 2.2U   | 1    |         |
|        | C1501    | FLJ1A106A024 | C.CAPACITOR CH 10V 10U    | 1    |         |
|        | C1502    | FLH1A4750001 | C.CAPACITOR CH 10V 4.7U   | 1    |         |
|        | C1503    | FLH1A4750001 | C.CAPACITOR CH 10V 4.7U   | 1    |         |
|        | C1504    | FLH1A105A025 | C.CAPACITOR CH 10V 1U     | 1    |         |
|        | C1505    | FLG1H1020008 | C.CAPACITOR CH 50V 1000P  | 1    |         |
|        | C1506    | FLG0J1050007 | C.CAPACITOR CH 6.3V 1U    | 1    |         |
|        | C1507    | FLG0J1050007 | C.CAPACITOR CH 6.3V 1U    | 1    |         |
|        | C2001    | FLG1A1040006 | C.CAPACITOR CH 10V 0.1U   | 1    |         |
|        | C2101    | FLH1A105A025 | C.CAPACITOR CH 10V 1U     | 1    |         |
|        | C2102    | FLG1A1040006 | C.CAPACITOR CH 10V 0.1U   | 1    |         |
|        | C4001    | FLG0J1050007 | C.CAPACITOR CH 6.3V 1U    | 1    |         |
|        | C4002    | FLG0J1050007 | C.CAPACITOR CH 6.3V 1U    | 1    |         |
|        | C4003    | FLH1A105A025 | C.CAPACITOR CH 10V 1U     | 1    |         |
|        | C4004    | FLH1A105A025 | C.CAPACITOR CH 10V 1U     | 1    |         |
|        | C4005    | FLH1A105A025 | C.CAPACITOR CH 10V 1U     | 1    |         |
|        | C4006    | FLH1A105A025 | C.CAPACITOR CH 10V 1U     | 1    |         |
|        | C4007    | FLH1A105A025 | C.CAPACITOR CH 10V 1U     | 1    |         |
|        | C4008    | FLG0J1050007 | C.CAPACITOR CH 6.3V 1U    | 1    |         |
|        | C4009    | FLG0J1050007 | C.CAPACITOR CH 6.3V 1U    | 1    |         |
|        | C4010    | FLH1C105A097 | C.CAPACITOR CH 16V 1U     | 1    |         |
|        | C4011    | FLH1E105A144 | C.CAPACITOR CH 25V 1U     | 1    |         |
|        | C4012    | FLH1C105A097 | C.CAPACITOR CH 16V 1U     | 1    |         |
|        | C4013    | FLH1C105A097 | C.CAPACITOR CH 16V 1U     | 1    |         |
|        | C5002    | FLG1A1040006 | C.CAPACITOR CH 10V 0.1U   | 1    |         |
|        | C5003    | FLG1A1040006 | C.CAPACITOR CH 10V 0.1U   | 1    |         |
|        | C5005    | FLG0J1050007 | C.CAPACITOR CH 6.3V 1U    | 1    |         |
|        | C5006    | FLG0J1050007 | C.CAPACITOR CH 6.3V 1U    | 1    |         |
|        | C5007    | FLG0J1050007 | C.CAPACITOR CH 6.3V 1U    | 1    |         |
|        | C5009    | FLH0J4750005 | C.CAPACITOR CH 6.3V 4.7U  | 1    |         |
|        | C5010    | FLG1A1040006 | C.CAPACITOR CH 10V 0.1U   | 1    |         |
|        | C5011    | FLG1A473A032 | C.CAPACITOR CH 10V 0.047U | 1    |         |
|        | C5012    | FLG0J1050007 | C.CAPACITOR CH 6.3V 1U    | 1    |         |
|        | C5013    | FLG0J1050007 | C.CAPACITOR CH 6.3V 1U    | 1    |         |
|        | C5017    | FLG1A473A032 | C.CAPACITOR CH 10V 0.047U | 1    |         |
|        | C5020    | FLG1C103A048 | C.CAPACITOR CH 50V 47P    | 1    |         |
|        | C5021    | FLG1C103A048 | C.CAPACITOR CH 50V 47P    | 1    |         |
|        | C6001    | FLG1A1040006 | C.CAPACITOR CH 10V 0.1U   | 1    |         |
|        | C6002    | FLG1A1040006 | C.CAPACITOR CH 10V 0.1U   | 1    |         |
|        | C6003    | FLG0J1050007 | C.CAPACITOR CH 6.3V 1U    | 1    |         |
|        | C6004    | FLG1C1030008 | C.CAPACITOR CH 16V 0.01U  | 1    |         |
|        | C6005    | FLG1C1030008 | C.CAPACITOR CH 16V 0.01U  | 1    |         |
|        | C6010    | FLG1A1040006 | C.CAPACITOR CH 10V 0.1U   | 1    |         |
|        | C6012    | FLG0J1050007 | C.CAPACITOR CH 6.3V 1U    | 1    |         |
|        | C6014    | FLH0J106A009 | C.CAPACITOR CH 6.3V 10U   | 1    |         |

**Model No. : DMC-SZ7 Parts List**

| Safety | Ref. No. | Part No.     | Part Name & Description  | Q'ty | Remarks |
|--------|----------|--------------|--------------------------|------|---------|
|        | C6015    | F1G0J1050007 | C.CAPACITOR CH 6.3V 1U   | 1    |         |
|        | C6017    | F1H0J1060009 | C.CAPACITOR CH 6.3V 10U  | 1    |         |
|        | C6019    | F1G0J1050007 | C.CAPACITOR CH 6.3V 1U   | 1    |         |
|        | C6020    | F1G1A1040006 | C.CAPACITOR CH 10V 0.1U  | 1    |         |
|        | C6021    | F1G1H100A565 | C.CAPACITOR CH 50V 10P   | 1    |         |
|        | C6022    | F1G1H100A565 | C.CAPACITOR CH 50V 10P   | 1    |         |
|        | C6023    | F1H0J106A009 | C.CAPACITOR CH 6.3V 10U  | 1    |         |
|        | C6025    | F1G0J1050007 | C.CAPACITOR CH 6.3V 1U   | 1    |         |
|        | C6026    | F1G1A1040006 | C.CAPACITOR CH 10V 0.1U  | 1    |         |
|        | C6027    | F1G1A1040006 | C.CAPACITOR CH 10V 0.1U  | 1    |         |
|        | C6030    | F1G0J1050007 | C.CAPACITOR CH 6.3V 1U   | 1    |         |
|        | C6032    | F1G0J1050007 | C.CAPACITOR CH 6.3V 1U   | 1    |         |
|        | C6033    | F1G0J1050007 | C.CAPACITOR CH 6.3V 1U   | 1    |         |
|        | C6034    | F1G0J1050007 | C.CAPACITOR CH 6.3V 1U   | 1    |         |
|        | C6037    | F1H0J1060009 | C.CAPACITOR CH 6.3V 10U  | 1    |         |
|        | C6038    | F1G0J1050007 | C.CAPACITOR CH 6.3V 1U   | 1    |         |
|        | C6044    | F1G1A1040006 | C.CAPACITOR CH 10V 0.1U  | 1    |         |
|        | C6045    | F1G1A1040006 | C.CAPACITOR CH 10V 0.1U  | 1    |         |
|        | C6050    | F1G1A1040006 | C.CAPACITOR CH 10V 0.1U  | 1    |         |
|        | C6401    | F1J0J2260004 | C.CAPACITOR CH 6.3V 22U  | 1    |         |
|        | C6402    | F1G0J1050007 | C.CAPACITOR CH 6.3V 1U   | 1    |         |
|        | C6403    | F1G1H100A565 | C.CAPACITOR CH 50V 10P   | 1    |         |
|        | C6405    | F1G1H100A565 | C.CAPACITOR CH 50V 10P   | 1    |         |
|        | C6406    | F1G1H100A565 | C.CAPACITOR CH 50V 10P   | 1    |         |
|        | C6407    | F1G1H100A565 | C.CAPACITOR CH 50V 10P   | 1    |         |
|        | C6408    | F1G1H100A565 | C.CAPACITOR CH 50V 10P   | 1    |         |
|        | C7001    | F1H1A105A025 | C.CAPACITOR CH 10V 1U    | 1    |         |
|        | C7003    | F1H1A105A025 | C.CAPACITOR CH 10V 1U    | 1    |         |
|        | C7006    | F1G1C1030008 | C.CAPACITOR CH 16V 0.01U | 1    |         |
|        | C7007    | F1G1C1030008 | C.CAPACITOR CH 16V 0.01U | 1    |         |
|        | C7008    | F1G1C1030008 | C.CAPACITOR CH 16V 0.01U | 1    |         |
|        | C7009    | F1G1C1030008 | C.CAPACITOR CH 16V 0.01U | 1    |         |
|        | C7010    | F1G0J1050007 | C.CAPACITOR CH 6.3V 1U   | 1    |         |
|        | C7011    | F1G0J1050007 | C.CAPACITOR CH 6.3V 1U   | 1    |         |
|        | C7014    | F1H1A105A025 | C.CAPACITOR CH 10V 1U    | 1    |         |
|        | C7019    | F1J1A106A043 | C.CAPACITOR CH 10V 10U   | 1    |         |
|        | C7101    | F1J0J1060009 | C.CAPACITOR CH 6.3V 10U  | 1    |         |
|        | C7102    | F1G1A1040006 | C.CAPACITOR CH 10V 0.1U  | 1    |         |
|        | C7104    | F1G1A1040006 | C.CAPACITOR CH 10V 0.1U  | 1    |         |
|        | C7105    | F1G1A1040006 | C.CAPACITOR CH 10V 0.1U  | 1    |         |
|        | C7106    | F1G1A1040006 | C.CAPACITOR CH 10V 0.1U  | 1    |         |
|        | C8001    | F1G0J1050007 | C.CAPACITOR CH 6.3V 1U   | 1    |         |
|        | C8006    | F1K2E4730005 | C.CAPACITOR 250V 0.047U  | 1    |         |
|        | C8007    | F1G1H4R0A564 | C.CAPACITOR CH 50V 22P   | 1    |         |
|        | C8008    | F1G1H101A557 | C.CAPACITOR CH 50V 100P  | 1    |         |
|        | C8009    | F1J1A106A043 | C.CAPACITOR CH 10V 10U   | 1    |         |
|        | C8018    | F1G0J1050007 | C.CAPACITOR CH 6.3V 1U   | 1    |         |
|        | C8051    | F1G1E472A086 | C.CAPACITOR CH 25V 4700P | 1    |         |
|        | C8052    | F1G1E472A086 | C.CAPACITOR CH 25V 4700P | 1    |         |
|        | C8060    | F1G1A1040006 | C.CAPACITOR CH 10V 0.1U  | 1    |         |
|        | C9020    | F1G1A1040006 | C.CAPACITOR CH 10V 0.1U  | 1    |         |
|        | C9021    | F1G1A1040006 | C.CAPACITOR CH 10V 0.1U  | 1    |         |
|        | C9022    | F1G1A1040006 | C.CAPACITOR CH 10V 0.1U  | 1    |         |
|        | C9101    | F1G1E102A086 | C.CAPACITOR CH 25V 1000P | 1    |         |
|        | C9102    | F1G0J1050007 | C.CAPACITOR CH 6.3V 1U   | 1    |         |
|        | C9103    | F1G1H120A565 | C.CAPACITOR CH 50V 12P   | 1    |         |
|        | C9104    | F1G1H150A565 | C.CAPACITOR CH 50V 15P   | 1    |         |
|        | C9106    | F1G0J1050007 | C.CAPACITOR CH 6.3V 1U   | 1    |         |
|        | C9108    | F1G1A1040006 | C.CAPACITOR CH 10V 0.1U  | 1    |         |
|        | C9109    | F1H0J106A009 | C.CAPACITOR CH 6.3V 10U  | 1    |         |
|        | C9111    | F1H1A105A025 | C.CAPACITOR CH 10V 1U    | 1    |         |
|        | C9521    | F1G0J1050007 | C.CAPACITOR CH 6.3V 1U   | 1    |         |

**Model No. : DMC-SZ7 Parts List**

| Safety   | Ref. No. | Part No.      | Part Name & Description | Q'ty | Remarks       |
|--|----------|---------------|-------------------------|------|---------------|
|  | CX6001   | F5A84103A020  | CAPACITOR NETWORKS      | 1    |               |
|  | D1060    | B0JCF0000003  | DIODE                   | 1    | E.S.D.        |
|  | D1501    | B0JCF0000003  | DIODE                   | 1    | E.S.D.        |
|  | D2001    | DB2S31100L    | DIODE                   | 1    | E.S.D.        |
|  | D6001    | DA2S10100L    | DIODE                   | 1    | E.S.D.        |
|  | D8001    | B3ADB0000142  | DIODE                   | 1    | E.S.D.        |
|  | D8002    | B0ECFR000003  | DIODE                   | 1    | E.S.D.        |
|  | D9101    | DB3S406F0L    | DIODE                   | 1    | E.S.D.        |
|  | D9102    | B0ADDH000014  | DIODE                   | 1    | E.S.D.        |
|  | D9501    | B3AAB0000343  | LED                     | 1    | E.S.D.        |
|  | ET9001   | K4ZZ01000208  | EARTH TERMINAL          | 1    |               |
|  | ET9002   | K4ZZ01000208  | EARTH TERMINAL          | 1    |               |
|  | F2001    | K5H1522A0018  | FUSE 32V 1.5A           | 1    |               |
|  | F2002    | K5H202Y000007 | FUSES                   | 1    |               |
|  | F8001    | ERBRE1R25V    | FUSE 32V 1.25A          | 1    |               |
|  | F8021    | ERBRE2R00V    | FUSE                    | 1    |               |
|  | FL2001   | EXC28CH900U   | MOUNTING LINE           | 1    |               |
|  | FL2002   | EXC28CH900U   | MOUNTING LINE           | 1    |               |
|  | FL2003   | F1H0J105A037  | C.CAPACITOR CH 6.3V 1U  | 1    |               |
|  | FP8051   | K1MY04BA0370  | CONNECTOR 4P            | 1    |               |
|  | FP9001   | K1MY51BA0235  | CONNECTOR 51P           | 1    |               |
|  | FP9002   | K1MY41BA0235  | CONNECTOR 41P           | 1    |               |
|  | FP9004   | K1MY47BA0235  | CONNECTOR 47P           | 1    |               |
|  | IC1001   | C1ZBZ0004588  | IC                      | 1    | E.S.D.        |
|  | IC1010   | C0DBGYY00821  | IC                      | 1    | E.S.D.        |
|  | IC1020   | C0DBGYY02557  | IC                      | 1    | E.S.D.        |
|  | IC1021   | C0DBGYY02527  | IC                      | 1    | E.S.D.        |
|  | IC1040   | C0DBGYY00779  | IC                      | 1    | E.S.D.        |
|  | IC1041   | C0DBGYY02497  | IC                      | 1    | E.S.D.        |
|  | IC1501   | C1ZBZ0004582  | IC                      | 1    | E.S.D.        |
|  | IC1502   | C1CB00003709  | IC                      | 1    | E.S.D.        |
|  | IC6001   | MN89504       | IC                      | 1    | E.S.D.        |
|  | IC6002   | RS10309       | IC                      | 1    | E.S.D.        |
|  | IC7101   | EWTS9PSL1A    | IC                      | 1    | E.S.D., [SPC] |
|  | IC8001   | C0ZBZ0001938  | IC                      | 1    | E.S.D.        |
|  | IC9101   | C1AB00003449  | IC                      | 1    | E.S.D.        |
|  | JK2001   | K1FB108E0008  | JACK, AV/USB            | 1    |               |
|  | JK2002   | K1FA119E0022  | JACK, HDMI              | 1    |               |
|  | L1010    | G1C4R7MA0392  | CHIP INDUCTOR 4.7UH     | 1    |               |
|  | L1020    | G1C3R3MA0392  | CHIP INDUCTOR 3.3UH     | 1    |               |
|  | L1030    | G1C4R7MA0328  | CHIP INDUCTOR 4.7UH     | 1    |               |
|  | L1040    | G1C2R2MA0392  | CHIP INDUCTOR 2.2UH     | 1    |               |
|  | L1050    | G1C2R2MA0392  | CHIP INDUCTOR 2.2UH     | 1    |               |
|  | L1060    | G1C100MA0428  | CHIP INDUCTOR 10UH      | 1    |               |
|  | L1501    | G1C4R7MA0428  | CHIP INDUCTOR 4.7UH     | 1    |               |
|  | L2001    | J0ZZB0000142  | FILTER                  | 1    |               |
|  | L8001    | G5F1A0000026  | CHIP INDUCTOR           | 1    |               |
|  | LB1001   | J0JHC0000048  | FILTER                  | 1    |               |
|  | LB1501   | J0JHC0000048  | FILTER                  | 1    |               |
|  | LB2001   | J0JCC0000415  | FILTER                  | 1    |               |
|  | LB2002   | J0JCC0000415  | FILTER                  | 1    |               |
|  | LB2003   | J0JCC0000415  | FILTER                  | 1    |               |
|  | LB2004   | J0JCC0000415  | FILTER                  | 1    |               |
|  | LB2005   | J0JYC0000061  | FILTER                  | 1    |               |
|  | LB2006   | J0JYC0000061  | FILTER                  | 1    |               |
|  | LB2007   | J0JYC0000061  | FILTER                  | 1    |               |
|  | LB2008   | J0JYC0000061  | FILTER                  | 1    |               |
|  | LB6002   | J0JCC0000412  | FILTER                  | 1    |               |
|  | LB6003   | J0JCC0000412  | FILTER                  | 1    |               |
|  | LB6004   | J0JCC0000317  | FILTER                  | 1    |               |
|  | LB6005   | J0JCC0000274  | COIL                    | 1    |               |
|  | LB8051   | J0JCC0000397  | FILTER                  | 1    |               |

**Model No. : DMC-SZ7 Parts List**

| Safety | Ref. No. | Part No.     | Part Name & Description  | Q'ty | Remarks                           |
|--------|----------|--------------|--------------------------|------|-----------------------------------|
|        | LB8052   | J0JCC0000397 | FILTER                   | 1    |                                   |
|        | P6401    | K1NA09E00098 | SD CARD CONNECTOR        | 1    |                                   |
|        | P8002    | K4ZZ03000344 | CONNECTOR 4P             | 1    |                                   |
|        | PP9001   | K1KA30BA0342 | CONNECTOR 30P            | 1    |                                   |
|        | PP9501   | K1KY16AA0749 | CONNECTOR 16P            | 1    |                                   |
|        | PS8001   | K1KB30AA0123 | CONNECTOR 30P            | 1    |                                   |
|        | PS9001   | K1KY16AA0748 | CONNECTOR 16P            | 1    |                                   |
|        | Q1501    | FG6943010R   | TRANSISTOR               | 1    | E.S.D.                            |
|        | Q6001    | B1CFHD000027 | TRANSISTOR               | 1    | E.S.D.                            |
|        | Q8001    | B1JBLP000038 | TRANSISTOR               | 1    | E.S.D.                            |
|        | QR1501   | DRC3114E0L   | TRANSISTOR-RESISTOR      | 1    | E.S.D.                            |
|        | QR6001   | DRC3144W0L   | TRANSISTOR-RESISTOR      | 1    | E.S.D.                            |
|        | R1006    | ERJ2RKD120X  | M.RESISTOR CH 1/16W 12   | 1    |                                   |
|        | R1051    | ERJ2RHD753X  | M.RESISTOR CH 1/16W 75K  | 1    |                                   |
|        | R1052    | ERJ2RKD154X  | M.RESISTOR CH 1/16W 150K | 1    |                                   |
|        | R1501    | ERJ2RHD103X  | M.RESISTOR CH 1/16W 10K  | 1    |                                   |
|        | R1502    | DOGA104JA023 | CHIP RESISTOR            | 1    |                                   |
|        | R1503    | DOGA104JA023 | CHIP RESISTOR            | 1    |                                   |
|        | R1507    | DOGA104JA023 | CHIP RESISTOR            | 1    |                                   |
|        | R1508    | DOGA472JA023 | CHIP RESISTOR            | 1    |                                   |
|        | R2001    | DOGA750JA023 | CHIP RESISTOR            | 1    |                                   |
|        | R2002    | DOGA561JA023 | CHIP RESISTOR            | 1    |                                   |
|        | R2003    | DOGA102JA023 | CHIP RESISTOR            | 1    |                                   |
|        | R2005    | DOGA102JA023 | CHIP RESISTOR            | 1    |                                   |
|        | R2009    | DOGA273JA023 | CHIP RESISTOR            | 1    |                                   |
|        | R2010    | DOGA202JA023 | CHIP RESISTOR            | 1    |                                   |
|        | R2011    | DOGA202JA023 | CHIP RESISTOR            | 1    |                                   |
|        | R2012    | ERJ2GEJ682X  | M.RESISTOR CH 1/16W 6.8K | 1    |                                   |
|        | R5011    | DOGA333JA023 | CHIP RESISTOR            | 1    |                                   |
|        | R5012    | DOGA222JA023 | CHIP RESISTOR            | 1    |                                   |
|        | R5013    | DOGA222JA023 | CHIP RESISTOR            | 1    |                                   |
|        | R5017    | DOGA333JA023 | CHIP RESISTOR            | 1    |                                   |
|        | R6002    | DOGA101JA023 | CHIP RESISTOR            | 1    |                                   |
|        | R6006    | ERJ2RKF6201X | M.RESISTOR CH 1/16W 6.2K | 1    |                                   |
|        | R6008    | DOGA105JA023 | CHIP RESISTOR            | 1    |                                   |
|        | R6009    | DOGA681JA023 | CHIP RESISTOR            | 1    |                                   |
|        | R6010    | DOGA103JA023 | CHIP RESISTOR            | 1    |                                   |
|        | R6013    | ERJ2RHD511X  | M.RESISTOR CH 1/16W 510  | 1    |                                   |
|        | R6014    | DOGA330JA023 | CHIP RESISTOR            | 1    |                                   |
|        | R6016    | DOGA472JA023 | CHIP RESISTOR            | 1    |                                   |
|        | R6017    | DOGA472JA023 | CHIP RESISTOR            | 1    |                                   |
|        | R6018    | ERJ2RKF1183X | M.RESISTOR CH 1/16W 118K | 1    |                                   |
|        | R6019    | ERJ2RHD222X  | M.RESISTOR CH 1/16W 2.2K | 1    |                                   |
|        | R6020    | ERJ2RHD122X  | M.RESISTOR CH 1/16W 1.2K | 1    |                                   |
|        | R6021    | DOGA473JA023 | CHIP RESISTOR            | 1    | P, PC, PU, EE, GC, GF, GA, GK, GN |
|        | R6022    | DOGA104JA023 | CHIP RESISTOR            | 1    |                                   |
|        | R6025    | DOGA101JA023 | CHIP RESISTOR            | 1    |                                   |
|        | R6029    | ERJ2RHD561X  | M.RESISTOR CH 1/16W 560  | 1    |                                   |
|        | R6046    | D0GAR00J0005 | CHIP RESISTOR            | 1    | EG, EP, EF, EB                    |
|        | R6052    | DOGA472JA023 | CHIP RESISTOR            | 1    |                                   |
|        | R6053    | ERJ2GEJ473X  | M.RESISTOR CH 1/16W 47K  | 1    | EG, EP, EF, EB                    |
|        | R6054    | DOGA103JA023 | CHIP RESISTOR            | 1    |                                   |
|        | R6401    | DOGA223JA023 | CHIP RESISTOR            | 1    |                                   |
|        | R6402    | DOGA102JA023 | CHIP RESISTOR            | 1    |                                   |
|        | R6403    | DOGA102JA023 | CHIP RESISTOR            | 1    |                                   |
|        | R7002    | ERJ2RKD680X  | M.RESISTOR CH 1/16W 68   | 1    |                                   |
|        | R7007    | ERJ2RKD680X  | M.RESISTOR CH 1/16W 68   | 1    |                                   |
|        | R7009    | D1BALR00A079 | CHIP RESISTOR            | 1    |                                   |
|        | R7021    | ERJ2RHD822X  | M.RESISTOR CH 1/16W 8.2K | 1    |                                   |
|        | R7030    | D0GBR00J0004 | CHIP RESISTOR            | 1    |                                   |
|        | R7109    | DOGA473JA023 | CHIP RESISTOR            | 1    |                                   |
|        | R8002    | D0GB104JA065 | CHIP RESISTOR            | 1    |                                   |

**Model No. : DMC-SZ7 Parts List**

| Safety | Ref. No. | Part No.     | Part Name & Description  | Q'ty | Remarks |
|--------|----------|--------------|--------------------------|------|---------|
|        | R8003    | D0GB820JA065 | CHIP RESISTOR            | 1    |         |
|        | R8005    | ERJ6GEYJ514V | M.RESISTOR CH 1/8W 510K  | 1    |         |
|        | R8006    | ERJ6GEYJ514V | M.RESISTOR CH 1/8W 510K  | 1    |         |
|        | R8013    | ERJ2RHD1621X | M.RESISTOR CH 1/16W 1620 | 1    |         |
|        | R8021    | D0GA303JA023 | CHIP RESISTOR            | 1    |         |
|        | R8022    | D0GA103JA023 | CHIP RESISTOR            | 1    |         |
|        | R8032    | D1BD4703A119 | CHIP RESISTOR            | 1    |         |
|        | R8037    | ERJ3GEYJ270V | M.RESISTOR CH 1/10W 27   | 1    |         |
|        | R8038    | D0GB330JA065 | CHIP RESISTOR            | 1    |         |
|        | R9001    | D0GA183JA023 | CHIP RESISTOR            | 1    |         |
|        | R9003    | D0GA183JA023 | CHIP RESISTOR            | 1    |         |
|        | R9005    | D0GA273JA023 | CHIP RESISTOR            | 1    |         |
|        | R9007    | D0GA151JA023 | CHIP RESISTOR            | 1    |         |
|        | R9008    | D0GA151JA023 | CHIP RESISTOR            | 1    |         |
|        | R9009    | D0GA331JA023 | CHIP RESISTOR            | 1    |         |
|        | R9021    | D0GA101JA023 | CHIP RESISTOR            | 1    |         |
|        | R9022    | D0GA102JA023 | CHIP RESISTOR            | 1    |         |
|        | R9024    | D0GA102JA023 | CHIP RESISTOR            | 1    |         |
|        | R9025    | D0GA102JA023 | CHIP RESISTOR            | 1    |         |
|        | R9026    | D0GA102JA023 | CHIP RESISTOR            | 1    |         |
|        | R9027    | D0GA102JA023 | CHIP RESISTOR            | 1    |         |
|        | R9041    | ERJ2RKF1000X | M.RESISTOR CH 1/16W 1K   | 1    |         |
|        | R9042    | ERJ2RKF1000X | M.RESISTOR CH 1/16W 1K   | 1    |         |
|        | R9043    | ERJ2RKF1000X | M.RESISTOR CH 1/16W 1K   | 1    |         |
|        | R9044    | ERJ2RKF1000X | M.RESISTOR CH 1/16W 1K   | 1    |         |
|        | R9047    | ERJ2RKF1000X | M.RESISTOR CH 1/16W 1K   | 1    |         |
|        | R9048    | ERJ2RKF1000X | M.RESISTOR CH 1/16W 1K   | 1    |         |
|        | R9049    | ERJ2RKF1000X | M.RESISTOR CH 1/16W 1K   | 1    |         |
|        | R9050    | ERJ2RKF1000X | M.RESISTOR CH 1/16W 1K   | 1    |         |
|        | R9106    | ERJ2GEJ824X  | M.RESISTOR CH 1/16W 820K | 1    |         |
|        | R9107    | D0GA334JA023 | CHIP RESISTOR            | 1    |         |
|        | R9109    | D0GA331JA023 | CHIP RESISTOR            | 1    |         |
|        | R9114    | ERJ2RHD183X  | M.RESISTOR CH 1/16W 18K  | 1    |         |
|        | R9115    | ERJ2RHD223X  | M.RESISTOR CH 1/16W 22K  | 1    |         |
|        | R9511    | D0GA242JA023 | CHIP RESISTOR            | 1    |         |
|        | R9512    | D0GA392JA023 | CHIP RESISTOR            | 1    |         |
|        | R9513    | D0GA752JA023 | CHIP RESISTOR            | 1    |         |
|        | R9514    | D0GA752JA023 | CHIP RESISTOR            | 1    |         |
|        | R9515    | D0GA392JA023 | CHIP RESISTOR            | 1    |         |
|        | R9516    | D0GA242JA023 | CHIP RESISTOR            | 1    |         |
|        | R9521    | D0GA512JA023 | CHIP RESISTOR            | 1    |         |
|        | R9522    | D0GA182JA023 | CHIP RESISTOR            | 1    |         |
|        | RX6001   | D1H81034A024 | RESISTOR NETWORKS        | 1    |         |
|        | RX6003   | D1H82214A024 | RESISTOR NETWORKS        | 1    |         |
|        | RX6004   | D1H82214A024 | RESISTOR NETWORKS        | 1    |         |
|        | RX6005   | D1H82214A024 | RESISTOR NETWORKS        | 1    |         |
|        | RX6006   | D1H82214A024 | RESISTOR NETWORKS        | 1    |         |
|        | RX6401   | D1H84734A024 | RESISTOR NETWORKS        | 1    |         |
|        | RX6402   | D1H84704A024 | RESISTOR NETWORKS        | 1    |         |
|        | S8001    | K0F212A00003 | SWITCH                   | 1    |         |
|        | S8002    | K0D112B00145 | SWITCH                   | 1    |         |
|        | S8003    | K0L1CB000003 | SWITCH                   | 1    |         |
|        | S8004    | K0F111A00541 | SWITCH                   | 1    |         |
|        | S9501    | K0F111A00541 | SWITCH                   | 1    |         |
|        | S9502    | K0F111A00541 | SWITCH                   | 1    |         |
|        | S9503    | K0F111A00541 | SWITCH                   | 1    |         |
|        | S9504    | K0F111A00541 | SWITCH                   | 1    |         |
|        | S9505    | K0F111A00541 | SWITCH                   | 1    |         |
|        | S9506    | K0F111A00541 | SWITCH                   | 1    |         |
|        | S9507    | K0F111A00541 | SWITCH                   | 1    |         |
|        | S9508    | K0F111A00541 | SWITCH                   | 1    |         |
|        | S9511    | K0D112B00145 | SWITCH                   | 1    |         |

**Model No. : DMC-SZ7    Parts List**

| Safety | Ref. No. | Part No.     | Part Name & Description | Q'ty | Remarks |
|--------|----------|--------------|-------------------------|------|---------|
|        | T8001    | G5DYA0000135 | TRANSFORMER             | 1    |         |
|        | VA9021   | D4ED18R0A014 | VARISTOR                | 1    |         |
|        | VA9022   | D4ED18R0A014 | VARISTOR                | 1    |         |
|        | X6001    | H0J240500068 | CRYSTAL OSCILLATOR      | 1    |         |
|        | X9101    | H0J327200225 | CRYSTAL OSCILLATOR      | 1    |         |

Model No. : DMC-SZ7 Frame and Casing Section

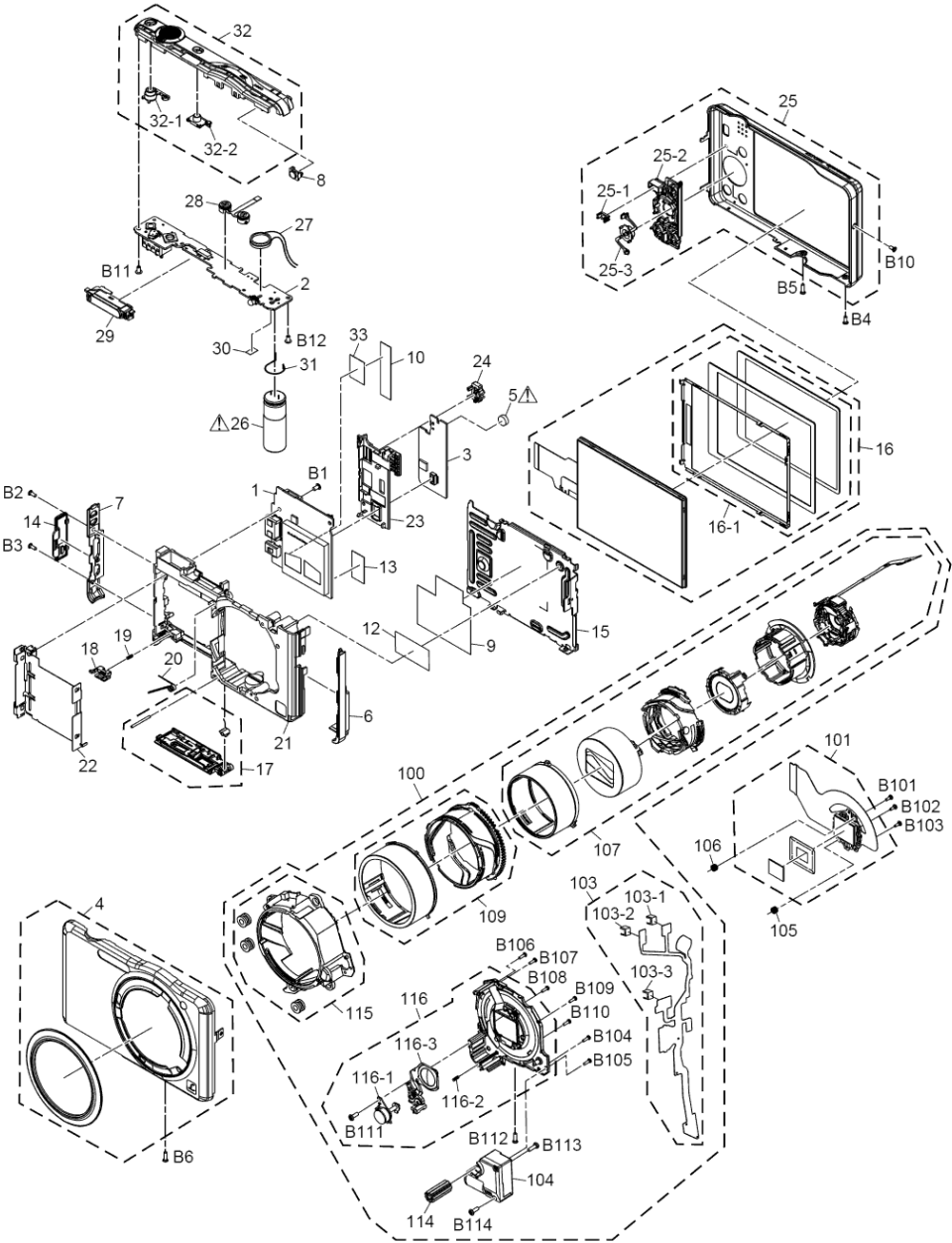

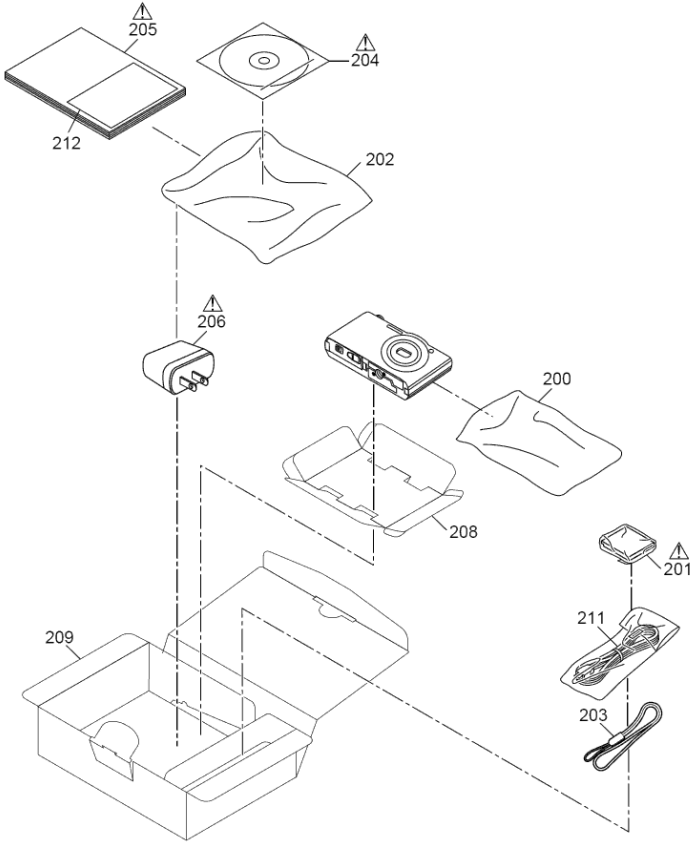

**Model No. : DMC-SZ7 Packing Parts and Accessories Section (1)**



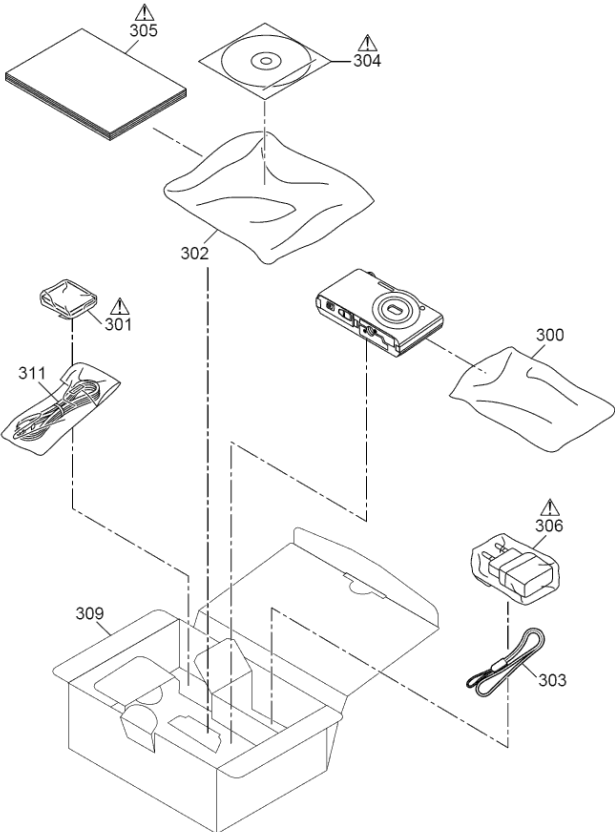





Model No. : DMC-SZ7 Packing Parts and Accessories Section (2)



**Model No. : DMC-SZ7 Parts List**

| Safety   | Ref. No. | Part No.     | Part Name & Description | Q'ty | Remarks   |
|--|----------|--------------|-------------------------|------|---|
|  | 1        | VEP56148A    | MAIN P.C.B.             | 1    | (RTL) , E.S.D. P,PC,PU,EE,GC,GF,GA,GK,GN                              |
|  | 1        | VEP56148B    | MAIN P.C.B.             | 1    | (RTL) , E.S.D. EG,EP,EF,EB  |
|  | 2        | VEP58166A    | FLASH TOP P.C.B.        | 1    | (RTL) , E.S.D.  |
|  | 3        | VEP59108A    | SUB OPERATION P.C.B.    | 1    | (RTL) , E.S.D.  |
|  | 4        | VYK5M49      | FRONT CASE UNIT         | 1    | P-K   |
|  | 4        | VYK5M12      | FRONT CASE UNIT         | 1    | PC-K,PU-K, EG-K,EP-K, EF-K, EB-K,EE-K, G<br>C-K,GF-K, GA-K, GK-K,GN-K |
|  | 4        | VYK5M11      | FRONT CASE UNIT         | 1    | (-W)  |
|  | 4        | VYK5M13      | FRONT CASE UNIT         | 1    | (-P)  |
|  | 4        | VYK5M14      | FRONT CASE UNIT         | 1    | (-T)  |
|    | 5        | ML-421S/DN   | BUTTON BATTERY          | 1    | (B9501) , [ENERGY]  |
|  | 6        | VGK3850      | SIDE ORNAMENT(R)        | 1    | (-K, -T)  |
|  | 6        | VGK3883      | SIDE ORNAMENT(R)        | 1    | (-W, -P)  |
|  | 7        | VGK3851      | SIDE ORNAMENT(L)        | 1    | (-K, -T)  |
|  | 7        | VGK3884      | SIDE ORNAMENT(L)        | 1    | (-W, -P)  |
|  | 8        | VGL1365      | AF PANEL LIGHT          | 1    |   |
|  | 9        | VGQ1C32      | PLATE SHEET             | 1    |   |
|  | 10       | VGQ1C44      | SHEET                   | 1    |   |
|  | 12       | VGQ1D41      | DPR SHEET               | 1    |   |
|  | 13       | VGQ1D49      | FPC TAPE                | 1    |   |
|  | 14       | VKF5091      | JACK DOOR               | 1    | (-K, -T)  |
|  | 14       | VKF5092      | JACK DOOR               | 1    | (-W, -P)  |
|  | 15       | VMP0B90      | FRAME PLATE             | 1    |   |
|  | 16       | VYK5M47      | LCD UNIT                | 1    |   |
|  | 16-1     | VYQ7890      | LCD PANEL UNIT          | 1    |   |
|  | 17       | VYK5R08      | BATTERY DOOR UNIT       | 1    | (-K)  |
|  | 17       | VYK5M18      | BATTERY DOOR UNIT       | 1    | (-W)  |
|  | 17       | VYK5M20      | BATTERY DOOR UNIT       | 1    | (-P)  |
|  | 17       | VYK5M21      | BATTERY DOOR UNIT       | 1    | (-T)  |
|  | 18       | VGU0H52-A    | BATTERY LOCK KNOB       | 1    |   |
|  | 19       | VMB4152-A    | BATTERY LOCK SPRING     | 1    |   |
|  | 20       | VMB4530      | BATTERY OUT SPRING      | 1    |   |
|  | 21       | VMP0B89      | FRAME                   | 1    |   |
|  | 22       | VMP0B92      | BATTERY CASE            | 1    |   |
|  | 23       | VGQ1A46      | PCB SPACER              | 1    |   |
|  | 24       | VGU0L29      | MODE KNOB               | 1    | (-K, -T)  |
|  | 24       | VGU0L26      | MODE KNOB               | 1    | (-W, -P)  |
|  | 25       | VYK5M34      | REAR CASE UNIT          | 1    | (-K)  |
|  | 25       | VYK5M33      | REAR CASE UNIT          | 1    | (-W)  |
|  | 25       | VYK5M35      | REAR CASE UNIT          | 1    | (-P)  |
|  | 25       | VYK5M36      | REAR CASE UNIT          | 1    | (-T)  |
|  | 25-1     | VGL1421      | REAR PANEL LIGHT        | 1    |   |
|  | 25-2     | VGU0K98      | CURSOR BUTTON           | 1    |   |
|  | 25-3     | VGU0K99      | MENU/SET BUTTON         | 1    |   |
|  | 26       | F2A2F8500013 | E.CAPACITOR             | 1    | (C8003)   |
|  | 27       | L0AA01A00098 | SPEAKER                 | 1    |   |
|  | 28       | L0CBAY000140 | MICROPHONE UNIT         | 1    |   |
|  | 29       | VEK0S64      | FLASH UNIT              | 1    |   |
|  | 30       | VGQ1C30      | TOP PCB SHEET           | 1    |   |
|  | 31       | VMB4604      | EARTH SPRING            | 1    | (ET8003)  |
|  | 32       | VYK5M45      | TOP CASE UNIT           | 1    | (-K, -T)  |
|  | 32       | VYK5M44      | TOP CASE UNIT           | 1    | (-W, -P)  |
|  | 32-1     | VGU0L25      | REC BUTTON              | 1    |   |
|  | 32-2     | VGU0L27      | POWER KNOB              | 1    |   |
|  | 33       | VGQ1D02      | DPR SHEET               | 1    |   |
|  | 100      | VXW1433      | LENS UNIT(W/O MOS)      | 1    | (-K, -T)  |
|  | 100      | VXW1432      | LENS UNIT(W/O MOS)      | 1    | (-W, -P)  |
|  | 101      | VEK0T13      | MOS FPC UNIT            | 1    |   |
|  | 103      | VEK0S66      | LENS FPC UNIT           | 1    |   |
|  | 103-1    | B3NBA0000011 | PHOTO SENSOR            | 1    |   |
|  | 103-2    | B3NBA0000011 | PHOTO SENSOR            | 1    |   |
|  | 103-3    | B3NBA0000018 | PHOTO SENSOR            | 1    |   |

# Model No. : DMC-SZ7 Parts List

| Safety   | Ref. No. | Part No.     | Part Name & Description             | Q'ty | Remarks                   |
|--|----------|--------------|-------------------------------------|------|---------------------------|
|  | 104      | L6DAYYYD0005 | ZOOM MOTOR UNIT                     | 1    |                           |
|  | 105      | VMB4603      | TILT SPRING                         | 1    |                           |
|  | 106      | VMB4603      | TILT SPRING                         | 1    |                           |
|  | 107      | VXP3819      | 1ST-3RD LENS FRAME UNIT             | 1    | (-K,-T)                   |
|  | 107      | VXP3818      | 1ST-3RD LENS FRAME UNIT             | 1    | (-W,-P)                   |
|  | 109      | VXP3760      | OUTSIDE DIRECT FRAME UNIT           | 1    | (-K,-T)                   |
|  | 109      | VXP3761      | OUTSIDE DIRECT FRAME UNIT           | 1    | (-W,-P)                   |
|  | 114      | VDG1781      | DRIVE GEAR                          | 1    |                           |
|  | 115      | VXQ2221      | FIX FRAME UNIT                      | 1    |                           |
|  | 116      | VXQ2222      | MASTER FLANGE UNIT                  | 1    |                           |
|  | 116-1    | L6HAYYYD0047 | FOCUS MOTOR UNIT                    | 1    |                           |
|  | 116-2    | VMB4593      | FOCUS SPRING                        | 1    |                           |
|  | 116-3    | VXP3768      | 4TH LENS FRAME UNIT                 | 1    |                           |
|  | B1       | VHD2004      | SCREW                               | 1    |                           |
|  | B2       | VHD2206      | SCREW                               | 1    | (-K,-T)                   |
|  | B2       | VHD2205      | SCREW                               | 1    | (-W,-P)                   |
|  | B3       | VHD2205      | SCREW                               | 1    | (-W,-P)                   |
|  | B3       | VHD2206      | SCREW                               | 1    | (-K,-T)                   |
|  | B4       | VHD2205      | SCREW                               | 1    | (-W,-P)                   |
|  | B4       | VHD2206      | SCREW                               | 1    | (-K,-T)                   |
|  | B5       | VHD2300      | SCREW                               | 1    | (-K,-T)                   |
|  | B5       | VHD2290      | SCREW                               | 1    | (-W,-P)                   |
|  | B6       | VHD2290      | SCREW                               | 1    | (-W,-P)                   |
|  | B6       | VHD2300      | SCREW                               | 1    | (-K,-T)                   |
|  | B10      | VHD2408      | SCREW                               | 1    | (-K,-T)                   |
|  | B10      | VHD2409      | SCREW                               | 1    | (-W,-P)                   |
|  | B11      | XQN16+BJ3FN  | SCREW                               | 1    |                           |
|  | B12      | XQN16+BJ3FN  | SCREW                               | 1    |                           |
|  | B101     | VHD2388      | SCREW                               | 1    |                           |
|  | B102     | VHD2388      | SCREW                               | 1    |                           |
|  | B103     | VHD2388      | SCREW                               | 1    |                           |
|  | B104     | VHD2430      | SCREW                               | 1    |                           |
|  | B105     | VHD2430      | SCREW                               | 1    |                           |
|  | B106     | VHD2390      | SCREW                               | 1    |                           |
|  | B107     | VHD2390      | SCREW                               | 1    |                           |
|  | B108     | VHD2390      | SCREW                               | 1    |                           |
|  | B109     | VHD2390      | SCREW                               | 1    |                           |
|  | B110     | VHD2390      | SCREW                               | 1    |                           |
|  | B111     | VHD2400      | SCREW                               | 1    |                           |
|  | B112     | VHD2400      | SCREW                               | 1    |                           |
|  | B113     | VHD2400      | SCREW                               | 1    |                           |
|  | B114     | VHD2400      | SCREW                               | 1    |                           |
|  | 200      | VPF1372-A    | CAMERA BAG                          | 1    | P,PC,PU                   |
|  | 201      | -----        | BATTERY                             | 1    | P,PC,PU                   |
|  | 202      | VPF1378      | BAG, POLYETHYLENE                   | 1    | P,PC,PU                   |
|  | 203      | VFC4297-B    | HAND STRAP                          | 1    | P,PC,PU                   |
|  | 204      | VFF0932-S    | CD-ROM                              | 1    | P,PC,PU [SPC] See "Notes" |
|  | 205      | VQT3Y79      | BASIC O/I (ENGLISH/SPANISH)         | 1    | P                         |
|  | 205      | VQT3Y80      | BASIC O/I (ENGLISH/CANADIAN FRENCH) | 1    | PC                        |
|  | 205      | VQT3Y81      | BASIC O/I (SPANISH/PORTUGUESE)      | 1    | PU                        |
|  | 206      | VSK0768      | AC ADAPTOR                          | 1    | P,PC,PU                   |
|  | 208      | VPN7381      | PAD                                 | 1    | P,PC,PU                   |
|  | 209      | VYQ7398      | PACKING CASE                        | 1    | P-K,PC-K                  |
|  | 209      | VYQ7406      | PACKING CASE                        | 1    | PC-W                      |
|  | 209      | VYQ7399      | PACKING CASE                        | 1    | PU-K                      |
|  | 209      | VYQ7407      | PACKING CASE                        | 1    | PU-P                      |
|  | 211      | K1HY08YY0025 | USB CABLE W/PLUG                    | 1    | P,PC,PU                   |
|  | 212      | VQL2C67-1A   | OPERATING LABEL                     | 1    | PC                        |
|  | 300      | VPF1372-A    | CAMERA BAG                          | 1    | EXCEPT P,PC,PU            |
|  | 301      | -----        | BATTERY                             | 1    | EXCEPT P,PC,PU            |
|  | 302      | VPF1378      | BAG, POLYETHYLENE                   | 1    | EXCEPT P,PC,PU            |
|  | 303      | VFC4297-B    | HAND STRAP                          | 1    | EXCEPT P,PC,PU            |

**Model No. : DMC-SZ7 Parts List**

| Safety | Ref. No. | Part No.     | Part Name & Description                   | Q'ty | Remarks                                    |
|--------|----------|--------------|---|------|--|
| ⚠      | 304      | VFF0933-S    | CD-ROM                                    | 1    | EG [SPC] See "Notes"                       |
| ⚠      | 304      | VFF0934-S    | CD-ROM                                    | 1    | EP,EF,EB [SPC] See "Notes"                 |
| ⚠      | 304      | VFF0935-S    | CD-ROM                                    | 1    | EE [SPC] See "Notes"                       |
| ⚠      | 304      | VFF0936-S    | CD-ROM                                    | 1    | GC,GF,GA,GN [SPC] See "Notes"              |
| ⚠      | 304      | VFF0938-S    | CD-ROM                                    | 1    | GK [SPC] See "Notes"                       |
| ⚠      | 305      | VQT3Y83      | BASIC O/I (GERMAN/FRENCH)                 | 1    | EG   |
| ⚠      | 305      | VQT3Y84      | BASIC O/I (ITALIAN/DUTCH)                 | 1    | EG   |
| ⚠      | 305      | VQT3Y85      | BASIC O/I (SPANISH/PORTUGUESE)            | 1    | EG   |
| ⚠      | 305      | VQT3Y86      | BASIC O/I (TURKISH)                       | 1    | EG   |
| ⚠      | 305      | VQT3Y87      | BASIC O/I (SWEDISH/DANISH)                | 1    | EP   |
| ⚠      | 305      | VQT3Y88      | BASIC O/I (POLISH/CZECH)                  | 1    | EP   |
| ⚠      | 305      | VQT3Y89      | BASIC O/I (HUNGARIAN/FINNISH)             | 1    | EP   |
| ⚠      | 305      | VQT3Y90      | BASIC O/I (FRENCH)                        | 1    | EF   |
| ⚠      | 305      | VQT3Y91      | BASIC O/I (ENGLISH)                       | 1    | EB   |
| ⚠      | 305      | VQT3Y92      | BASIC O/I (RUSSIAN/UKRAINIAN)             | 1    | EE   |
| ⚠      | 305      | VQT3Y93      | BASIC O/I (ENGLISH/CHINESE (TRADITIONAL)) | 1    | GC,GF,GA                                   |
| ⚠      | 305      | VQT3Y94      | BASIC O/I (ARABIC/PERSIAN)                | 1    | GC,GF                                      |
| ⚠      | 305      | VQT3Y95      | BASIC O/I (VIETNAMESE)                    | 1    | GA   |
| ⚠      | 305      | VQT3Y97      | BASIC O/I (CHINESE (SIMPLIFIED))          | 1    | GK   |
| ⚠      | 305      | VQT3Y98      | BASIC O/I (ENGLISH)                       | 1    | GN   |
| ⚠      | 306      | VSK0772      | AC ADAPTOR                                | 1    | EG,EP,EF,EE,GF,GA                          |
| ⚠      | 306      | VSK0775      | AC ADAPTOR                                | 1    | EB,GC                                      |
| ⚠      | 306      | VSK0770      | AC ADAPTOR                                | 1    | GK   |
| ⚠      | 306      | VSK0776      | AC ADAPTOR                                | 1    | GN   |
|        | 309      | VYQ7400      | PACKING CASE                              | 1    | EG-K,EP-K,EF-K, EB-K, EE-K, GC-K,GA-K,GN-K |
|        | 309      | VYQ7390      | PACKING CASE                              | 1    | EG-W,EB-W,GA-W,GN-W                        |
|        | 309      | VYQ7414      | PACKING CASE                              | 1    | EG-T,EF-T,EB-T,EE-T,GA-T                   |
|        | 309      | VYQ7408      | PACKING CASE                              | 1    | GC-P,GA-P,GN-P                             |
|        | 309      | VYQ7403      | PACKING CASE                              | 1    | GF-K                                       |
|        | 309      | VYQ7395      | PACKING CASE                              | 1    | GF-W                                       |
|        | 309      | VYQ7411      | PACKING CASE                              | 1    | GF-P                                       |
|        | 309      | VYQ7417      | PACKING CASE                              | 1    | GF-T                                       |
|        | 309      | VYQ7404      | PACKING CASE                              | 1    | GK-K                                       |
|        | 309      | VYQ7396      | PACKING CASE                              | 1    | GK-W                                       |
|        | 309      | VYQ7412      | PACKING CASE                              | 1    | GK-P                                       |
|        | 309      | VYQ7418      | PACKING CASE                              | 1    | GK-T                                       |
|        | 311      | K1HY08YY0025 | USB CABLE W/PLUG                          | 1    | EXCEPT P,PC,PU                             |