

Operation Manual



Extended Hold Bin
EHBTH34-1 Series



ATTENTION: Read the instructions before using the machine.

LIMITED WARRANTY

This product is warranted to be free from defects in material and/or workmanship for a period of 3 years (repair parts) and 2 years (service labor) from date of original installation, not to exceed 30 months from the date of manufacture.

Any component which proves to be faulty in material and/or workmanship will be replaced or repaired (at the option of Prince Castle LLC) without cost to the customer for parts and labor. This warranty covers on location service (i.e. trip charges and or mileage). Travel mileage is limited to 100 miles (200 Kilometers) round trip (one trip warranty) from an authorized service agency or its sub-service agency.

This warranty is subject to the following exceptions/conditions:

- Use of any non-genuine Prince Castle parts voids this warranty.
- All labor to be performed during regular work hours. Overtime premium (the incremental amount) will be charged to the customer.
- Damage caused by carelessness, neglect and/or abuse (e.g., dropping, tampering or altering parts, equipment damaged in shipment, by fire, flood or an act of nature) is not covered under this warranty.
- All problems due to operation at voltages other than that specified on equipment nameplates are not covered by this warranty. Conversion to correct voltage is the customer's responsibility.
- This equipment must be serviced by Prince Castle Authorized Service Agency or a Prince Castle Service Technician during the warranty period.

TABLE OF CONTENTS

Model Identification	2
Model Specifications	3
Safety Information	3
Installation	3
Product Identification	4
Operation	4
Setting the Temperature	6
Calibrating the Heaters	7
Changing the Hold and Cook More Times	8
Changing Product Names	9
Changing Temperature Scale	10
Adjusting Alarm Volume	10
Choosing a Language	11
Selecting the Daypart	11
Setting Product Location	12
Cleaning	12
Default Menu	13
Zone Layouts	13
Troubleshooting	14
Diagnostics	15
Wiring Diagram	16
Exploded Views	17



355 EAST KEHOE BLVD. ~ CAROL STREAM, IL, 60188, USA
PHONE: 630-462-8800 ~ TOLL FREE: 1-800-PCASTLE
FAX 630-462-1460 ~ WWW.PRINCECASTLE.COM

Dedicated Holding Bin

EHBTH34-1 Series



Model Identification

EHBTH24ACE-1

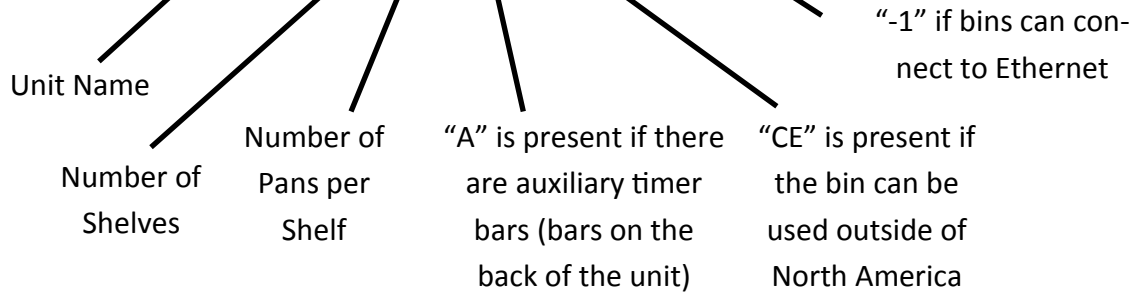

Serial Number Matrix

The manufacture date is encoded in the unit's serial number.
 The service bench installation date (used to determine warranty coverage) is considered to be the end of the following month. For example:

Serial Number: JL0173804
 Manufacture Date: September 2016
 Service Bench Installation Date: October 31, 2016

		SERIAL NUMBER MATRIX							
		2016	2017	2018	2019	2020	2021	2022	2023
		L	M	N	P	R	S	T	U
January	A	AL	AM	AN	AP	AR	AS	AT	AU
February	B	BL	BM	BN	BP	BR	BS	BT	BU
March	C	CL	CM	CN	CP	CR	CS	CT	CU
April	D	DL	DM	DN	DP	DR	DS	DT	DU
May	E	EL	EM	EN	EP	ER	ES	ET	EU
June	F	FL	FM	FN	FP	FR	FS	FT	FU
July	G	GL	GM	GN	GP	GR	GS	GT	GU
August	H	HL	HM	HN	HP	HR	HS	HT	HU
September	J	JL	JM	JN	JP	JR	JS	JT	JU
October	K	KL	KM	KN	KP	KR	KS	KT	KU
November	L	LL	LM	LN	LP	LR	LS	LT	LU
December	M	ML	MM	MN	MP	MR	MS	MT	MU

Model Specifications

STYLE	MODEL NO.	WIDTH (mm)	HEIGHT (mm)	DEPTH (mm)	WEIGHT (kgs)	VOLTAGE	AMPS	PLUG
3H X 4W	EHBTH34-1	33.2" (843)	16.2" (413)	14.1" (358)	83 lbs (38)	208-240V	13.5-15.6	6-20P

NOTE: Weight (kgs) is product weight.

Safety Information



WARNING

Indicates information important to the proper operation of the unit. Failure to observe may result in damage to the equipment and/or severe bodily injury or death.



CAUTION

Indicates information important to the operation of the unit. Failure to observe may result in damage to the equipment.

Important

Prince Castle reserves the right to change specifications and product design without notice. Such revisions do not entitle the buyer to corresponding changes, improvements, additions or replacements for previously purchased equipment.

Installation

1

Remove the unit from the carton and inspect for signs of damage. If there is damage to the unit:

- notify the carrier within 24 hours of delivery
- save carton and packaging materials for inspection purposes
- contact your local dealer, or if purchased directly, the Prince Castle Sales Department at 800-722-7853 or 1-630-462-8800 to arrange for a replacement unit.

NOTE: Plug the power cord into the proper electrical receptacle. All electrical connections must be in accordance with local electrical codes and any other applicable codes.

2

Place Holding Bin on flat surface. Remove blue and/or white protective covering.

NOTE: When installing this unit, the ambient temperature at the mounting site should not exceed 100°F (38°C)

3

Plug unit into a grounded receptacle with a matching plug configuration.

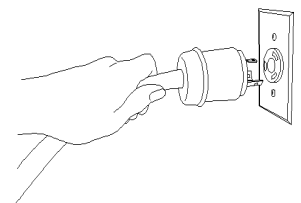

WARNING:

All electrical connections must be in accordance with local electrical codes and any other applicable codes. If the supply cord is damaged, it must be replaced by the manufacturer, its service agent, or similarly qualified persons in order to avoid a hazard. To prevent an electric shock hazard this device must be bonded to equipment in close proximity with an equipotential bonding conductor. This device is equipped with a grounding lug for this purpose.

NOTICE – This product is not intended for connection to the residential public low-voltage supply system.

Dedicated Holding Bin

EHBTH34-1 Series



Product Identification

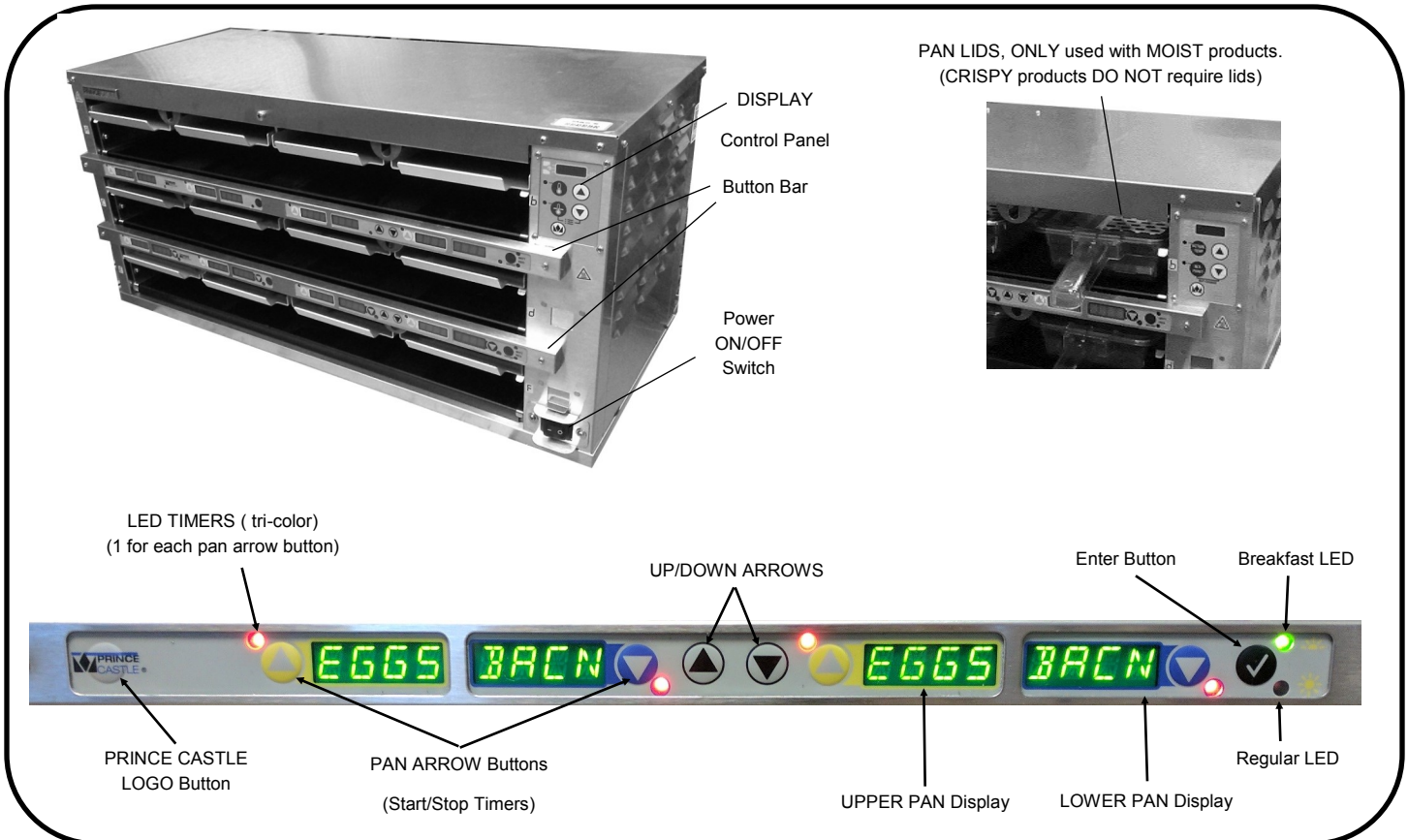

Operation



WARNING: This application is not intended for use by persons (including children) with reduced physical, sensory or mental capabilities, or lack of experience and knowledge, unless they have been given supervision or instruction concerning use of the appliance by a person responsible for their safety.

- 1 To turn on the unit,
Turn Power On/Off switch (A) to **ON** position.



Allow 20 minutes for heaters to reach operating temperature. The button bar will read "WARM UP" as the unit warms up, they will display the product names.

NOTE: Load pan covers (if used) and insert pans into the unit.

- 2 Press all Pan Arrow buttons.
The Pan displays will show the assigned product name.



If no product is assigned, the display will be dim and show "----". Pressing the Pan Arrow button will not activate the timer if "----" is displayed. Pressing Pan Arrow button when product name is displayed will start timing cycle.

BKFT (Breakfast) or **REG** (Regular Menu) will be lit depending on pre-programmed menu.

Operation

3 LED Timing Status



LED TIMERS

- BLANK** (steady) = Ready for product
- RED** (flashing) = Discard product
- GREEN** (steady) = Oldest product, use first
- GREEN** (flashing) = Cook more product
- YELLOW** (steady) = Newer product, use green first
- YELLOW** (flashing) = Cook more product

4 When **LED** is **BLANK**, load product and press the Pan Arrow button.



If only one pan is active for a product, the **LED** will turn from **BLANK** to **GREEN**.

If more than one pan is active for a product, the **LED** for the first pan loaded will turn from **BLANK** to **GREEN**.

The **LED** for the 2nd pan loaded with the same product will turn from **BLANK** to **YELLOW**.

The **LED** timer can be stopped (cancelled) at any time by pressing and releasing the corresponding **PAN** Arrow button.

5 When any of the timer **LED** flash, cook more product or remove and discard product as indicated.

- GREEN** (flashing) = Cook more product
- YELLOW** (flashing) = Cook more product
- RED** (flashing) = Discard product



WARNING: HOT SURFACES

Dedicated Holding Bin

EHBTH34-1 Series



Setting the Temperature

The unit has multiple shelves, each with an upper and lower heater for each zone. The heaters follow the default set points of the preset products for each pan. Use the instructions below and the following steps to set the set point temperatures for each heater.

UPPER SHELF LED
This LED will be lit to indicate upper shelf is selected.

PROG LED
This LED will be lit to indicate unit is in Program Mode.

LOWER SHELF LED
This LED will be lit to indicate lower shelf is selected.

ACTUAL TEMP BUTTON and LED
Press to display actual temperature for the selected heater. LED will be lit when actual temperature is displayed.

SETPOINT BUTTON and LED
Press to display set point temperature of a selected heater. LED will be lit when set point temperature is displayed.

TEMPERATURE DISPLAY
A, B, C, D (E, F) = ZONES
Upper and Lower Heater

UP/DOWN ARROW BUTTONS
Used with other Buttons to scroll through heater and temperature selections.

CROWN BUTTON
Press to enter temperature selections.

CAUTION:
DISPLAYED TEMPERATURES ARE HEATER TEMPERATURES AND DO NOT INDICATE ACTUAL FOOD TEMPERATURES.

NOTE: To reset all calibrations to the factory settings, turn the unit off, then press and hold the UP and DOWN Arrow buttons simultaneously while turning the unit back on. A "P" will appear in the display and all calibrations will be reset to original factory settings.

1 The **SET PRODUCT TEMP** menu is used to change the Hold and Cook-More times. Press and hold the **PRINCE CASTLE LOGO** button on the button bar, then immediately press and hold the **ENTER** button until the display shows one of six programming menus.....(hold for about 5 seconds)
Use the **UP** or **DOWN** Arrow button to scroll to the **PROD EGGS** ↑ ↓ **ENTR** (Set Product Temperature) menu.

2 Press the **ENTER** button to enter the programming menu, the display should then read **SEL TEMP XXXX** ↑ ↓ . The **XXXX** is where the product abbreviation is displayed. Use the black **UP** and **DOWN** arrows to navigate to the desired product.

3 Press the **ENTER** button to select that product profile to update, the display will read **SET UPR XXXX ###s** ↑ ↓ the **XXXX** is where the product abbreviation is displayed, and **###** is the temperature. Use the **UP** and **DOWN** arrows to set the temperature of the upper heater of that zone.
Confirm set point by pressing **ENTER**

Setting the Temperature (Continued)

4 The display will now show **SET LWR XXXX ###s** ↑ ↓. Use the **UP** and **DOWN** arrows to set the temperature of the Lower heater of that zone. Press **ENTER** to confirm setpoint temperature.



5 Press **PRINCE CASTLE LOGO BUTTON** to save the setpoints. Repeat steps 2-5 for all necessary profile upgrades.



NOTE: Setpoints are displayed on the front display board, and should be updated according to the product at this point.

Calibrating Heaters

1 Use the following steps to calibrate the individual heaters

Press the **UP** or **DOWN** Arrow button until the desired shelf **LED** and upper or lower heater is selected.

NOTE: Allow sufficient amount of time for temperatures to stabilize before starting calibration. (approx. 30 mins.)

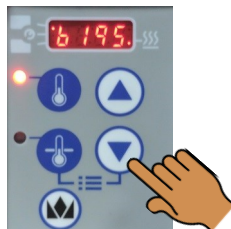

2 Take a temperature reading within the shelf near the center of each heater surface.

WARNING: HOT SURFACES
 Use caution when taking temperature readings within the shelf.

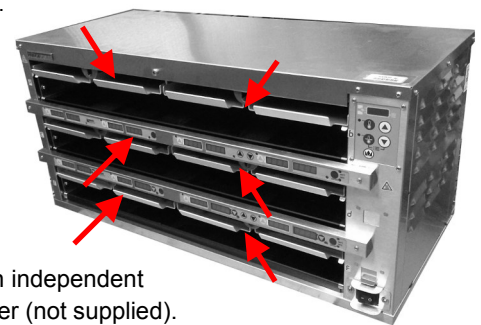

NOTE: Use an independent Temperature meter (not supplied).

3 Press and hold the **CROWN BUTTON** and **ACTUAL TEMP** buttons for 5 seconds. The colon (:) LED indicator will light. The temperature displayed is the actual heater temperature sensed by the controller. To clear any offset readings, press the **SETPOINT** button.

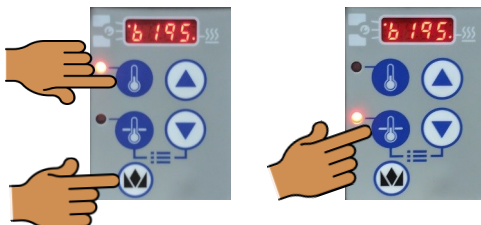

4 Press the **UP** or **DOWN** Arrow button until the temperature displayed matches the reading obtained in Step 2. Press the **CROWN BUTTON** to save the temperature value and exit the Calibration Mode.

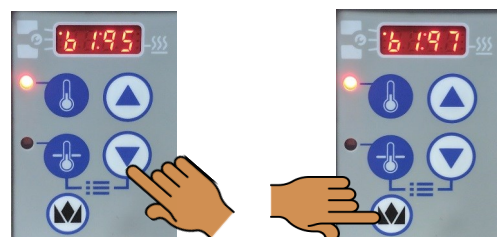

Dedicated Holding Bin

EHBTH34-1 Series



Changing the Hold and Cook-More Times

1 The **SET PRODUCT TIME** menu is used to change the Hold and Cook-More times. Press and hold the **PRINCE CASTLE LOGO** button on the button bar, then immediately press and hold the **ENTER** button until the display shows one of six programming menus. Use the UP or DOWN Arrow button to scroll to the **PROD TIME** ↑ ↓ **ENTR** (Set Product Time) menu.



2 Press and release the **ENTER** button to enter the Set Product Time menu. The display will show **EGGS TIME** ↑ ↓ **ENTR**. Use the **UP** or **DOWN** Arrow button to scroll through the list of products. When the desired product is displayed, press the **ENTER** button to select it.



NOTE: Holding the UP or DOWN Arrow button for longer than 2 seconds will cause the product list to automatically scroll up or down.

3 The display will show **240** ↑ ↓ **ENTR**.



Use the **UP** or **DOWN** Arrow button to scroll to the desired Hold time. When the desired Hold time is displayed, press the **ENTER** button to save the desired Hold time.

NOTE: Hold time cannot be reduced to less than the Cook-More time plus one minute. NOTE: All times are displayed in minutes only. For example, 2 and half hours is displayed as 150.

4 The display will show **COOK 30** ↑ ↓ **ENTR**.



Use the **UP** or **DOWN** Arrow button to scroll to the desired Cook-More time. When the desired Cook-More time is displayed, press the **ENTER** button to save it.

NOTE: Cook-More time cannot be increased to more than the Hold time, minus one minute.

5 The display will show **EGGS TIME** ↑ ↓ **ENTR**. Repeat Steps 2 – 4 for any other product. Press and release the **PRINCE CASTLE LOGO** button at any time to exit the Program Mode and return to the Run Mode.

NOTE: If the ENTER button has not been pressed to save any changes, the program will revert to the original values.



Changing Product Names

- 1** The **EDIT PRODUCT NAME** menu is used to change a default product name to one of your own choosing. Press and hold the **PRINCE CASTLE LOGO** button on the button bar, then immediately press and hold the **ENTER** button until the display shows one of six programming menus. Use the **UP** or **DOWN** Arrow button to scroll to the **PROD NAME** ↑ ↓ **ENTR** (Edit Product Name) menu.



NOTE: The default menu items and names are listed on page 13.

- 2** Press and release the **ENTER** button to enter the Edit Product Name menu. Use the **UP** or **DOWN** Arrow button to scroll through the list of products. When the desired product is displayed, press the **ENTER** button to select it. The first letter (in this case, the **E**) will start blinking.



- 3** To change the blinking **E**, use the **UP** or **DOWN** Arrow button to scroll to the desired letter/number/symbol. When the desired selection is displayed, press the **PAN** Arrow button to move to the next digit. Repeat for all digits.



NOTE: Holding the UP or DOWN Arrow button for longer than 2 seconds will cause the display to automatically scroll up or down.

- 4** When all four digits have been changed, press the **ENTER** button to select the new name.



- 5** The display will show **PROD NAME** ↑ ↓ **ENTR**. Repeat Steps 2 – 4 for any other product. Press and release the **PRINCE CASTLE LOGO** button at any time to exit the Program Mode and return to the Run Mode.



NOTE: If the ENTER button has not been pressed to save any changes, the program will revert to the original names.

Dedicated Holding Bin

EHBTH34-1 Series



Changing Temperature Scale

- 1 The **SET F/C** menu is used to change the temperature scale.
Press and hold the **PRINCE CASTLE LOGO** button on the button bar, then immediately press and hold the **ENTER** button until the display shows one of six programming menus. Use the **UP** or **DOWN** Arrow button to scroll to the **SET F/C XXXX** ↑ ↓ **ENTR** (Edit Product Name) menu.



- 2 Press the **ENTER** button to enter the menu.
Bar will display **SET DEGR F/C** ↑ ↓ **ENTR** and either the **F** or **C** will be blinking.



Use the **UP** and **DOWN** arrows to select the desired temperature mode (the selected mode will blink). Press the **ENTER** button to confirm the selection. Press the **PRINCE CASTLE LOGO** button to save the setting.

Adjusting Alarm Volume

- 1 The **SET VOLUME** menu is used to change the alarm volume when a timer expires. It is adjustable from level 0 to 3.
Press and hold the **PRINCE CASTLE LOGO** button on the button bar, then immediately press and hold the **ENTER** button until the display shows one of six programming menus. Use the **UP** or **DOWN** Arrow button to scroll to the **SET VOL** ↑ ↓ **ENTR** (Set Volume) menu.



NOTE: Only applicable in stand-alone mode when not connected to Product Management system.

Use the **UP** and **DOWN** arrows to select the desired volume level (the selected level will blink). Press the **ENTER** button to confirm the selection. Press the **PRINCE CASTLE LOGO** button to save the setting.

Choosing a Language

- 1 The **SET LANGUAGE** menu is used to change the language between English and French.
 Press and hold the **PRINCE CASTLE LOGO** button on the button bar, then immediately press and hold the **ENTER** button until the display shows one of six programming menus.
 Use the **UP** or **DOWN** Arrow button to scroll to the **SET LANG** ↑ ↓ **ENTR** (Set Language) menu.



- 2 Use the black arrow buttons to select **ENGLISH** or **FRENCH**



Press the **ENTER** button when desired language is selected. Press the **Prince Castle** button to exit the settings menu.

Selecting the Daypart

- 1 Press and hold the **SETPOINT** button and the **DOWN** Arrow button for 3 seconds, the current day part will begin flashing on the screen.
 Use the **up/down** arrows to select day part 1 through 6 and the **Prince Castle Crown** button to confirm your selection.
NOTE: Whenever a bin is powered **ON** it defaults to **DAY**

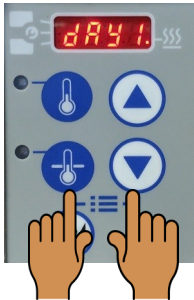

Dedicated Holding Bin

EHBTH34-1 Series



Setting Product Location

1 To change a menu selection for a specific pan cavity, use the following steps:

- A. Press and hold the **PRINCE CASTLE LOGO** button for 6 seconds. All Pan displays will show **PROG**. All LED Timers will be **RED**.
- C. Press the **UP** or **DOWN** Arrow button to scroll to the desired menu item.
- D. Press the **ENTER** button to select the menu item.



- B. Press a Pan Arrow button to change the menu. The **LED** Timer will change to **YELLOW** and the display will change from **PROG** to the assigned menu item.
- E. Repeat steps A – D as required for other Pan displays. Press the **PRINCE CASTLE LOGO** button to exit the Program Mode.

NOTE: A pan may be set as “not used” by assigning “- - -” as its product.

NOTE: Setting a pan to a particular product will automatically change the other pan in that zone to the same product.

2 To shut down the unit, turn the Power On/Off switch (A) to **OFF** position.



Cleaning

WARNING:
Before performing any maintenance, turn the power switch to the OFF position and unplug the power cord from the electrical receptacle.

CAUTION:
This unit is not watertight. Do not clean with a water jet/jet spray. Do not immerse the unit in water.
1. Turn the unit off and unplug the power cord from electrical receptacle.
2. Remove the pans and covers. Wipe all parts and unit with a damp cloth.
DO NOT use a green Scotch Bright pad cleaner, ice or water.

Default Menu Items

Product Names		Display Name		Hold Time (Minutes)	Cook-More (Minutes)	Upper Temp		Lower Temp	
English	French	English	French			F	C	F	C
Group 1									
Eggs	Oeufs	EGGS	OEUF	240	30	200	93	180	82
Bacon	Bacon	BACN	BAC	180	15	200	93	180	82
Veggies	Legumes	VEG	LEG	240	15	200	93	180	82
Sausage	Saucisses	SAUS	SAU	240	30	200	93	180	82
Turkey Sausage	Saucisse a la dinde	TURK	SAUD	240	30	200	93	180	82
Steak	Steak	STK	STK	240	30	200	93	180	82
Pasta	Pates	PSTA	PATE	240	60	200	93	180	82
Pork	Porc	PORK	PORC	360	60	200	93	180	82
Ham	Jambon	HAM	JAMB	120	15	200	93	180	82
Chicken Strip	Lanieres de poulet	CHKS	POUL	240	30	200	93	180	82
Group 2									
Crispy Chicken	Poulet Croustillant	CCHK	PCRO	120	30	265	129	275	135
Hash Brown	Galette de Pommes de Terre	HSBR	GLPT	120	30	265	129	275	135
Potato Wedge	Pomme de Terre le morceau	PWGE	PAQT	90	30	265	129	275	135

Zones

All bin configurations are set up with zones, which correspond to a set of heaters that work together to hold the product. A single product can be programmed into each zone.

The timer bars are equipped with this knowledge. If the product in one slot of a zone is changed, the other slot will automatically change to that product as well if they are not in the same Group (see Default Menu Items).

3X4



Dedicated Holding Bin

EHBTH34-1 Series



Troubleshooting

⚠ WARNING: To avoid personal injury and possible damage to the unit, troubleshooting and repair of electrical equipment should be performed by qualified service personnel. This unit should be unplugged when servicing. Except when electrical tests are required. Use extreme caution during electrical circuit tests as live circuits may be exposed.

Problem	Probable Cause	Solution
No Power	Power switch is turned off, Power cord is not plugged in.	Turn power switch to ON position, Ensure power cord is connected to proper receptacle
Unit will not heat up	Wrong power cord, loose connection on power switch and/or heater	CALL TECH SUPPORT 1-800-722-7853
Unit heats up but timer bars do not work	Timer bar wiring disconnected, timer bar is defective	CALL TECH SUPPORT 1-800-722-7853
Unit under/over heats	Check temperature settings	CALL TECH SUPPORT 1-800-722-7853
Display flashes OPN and REL	Open relay, circuit or heater inoperable	CALL TECH SUPPORT 1-800-722-7853
Display flashes SHR and REL	Shorted relay, circuit inoperable, open heater, unplugged ribbon cable	CALL TECH SUPPORT 1-800-722-7853
Display shows HHH for extended period and heat- er surface temperature is hot	Temperature is above 300 F (149 C), Abnormal operation	CALL TECH SUPPORT 1-800-722-7853
Display shows HOLD	Only displayed on a 3X4 Bin display board, when the operator changes the bin address or during calibration	HOLD message means the 2 PC boards in the bin are communicating, wait until the message disappears
Display shows WAIT	When in stand alone mode and the oper- ator makes change to the product profile	Wait until the message disappears
Display shows INIT	When switching from Kitchen Minder to stand alone mode	Bin is learning Kitchen Minder menus, wait for message to disappear
Timer bar displays COMM DOWN	Bin is not communicating with Kitchen Minder	Refer to Kitchen Minder setup manual

For all technical support in North America, please contact **PRINCE CASTLE LLC 1-800-722-7853**
For technical support worldwide, contact your local service representative / installer.

Diagnosics

DIAGNOSTICS

For all diagnostic messages on the holding bin, the message will appear on the timer bar located at the pan that is triggering the message.

The message is a two-word message that will cycle through on the timer bar in addition to the product name at that pan location.

1. WARM | UP | XXXX – When turning on holding bin the warm up message will appear until heaters reach within 15°F set point.
 - a. Cleared when within 15°F of the set point.
2. HTR | OFF | XXXX – Heater off message appears when both the upper and lower heaters are off.
 - a. Cleared when heater is turned on.
3. HTR | LOW | XXXX – Heater low appears if the temperature falls 15°F below the set point.
 - a. Cleared when temperature is back in range. If not cleared, would require a service technician to repair.
4. HTR | HIGH | XXXX – Heater high appears if the heater is above 285°F for 20 minutes.
 - a. Cleared when temperature is back in range. If not cleared, would require a service technician to repair.
5. RLY | SHRT | XXXX – Relay short error occurs when there is a thermocouple or heater problem.
 - a. Bin requires service to further troubleshoot and repair.
6. RLY | OPEN | XXXX – Relay open error occurs when there is a thermocouple or heater problem.
 - a. Bin requires service to further troubleshoot and repair.
7. COMM | DOWN | XXXX – Communication down error occurs when the temperature data is not being properly communicated.
 - a. Check that unit is in bin1/BAR2/BAR3. Otherwise, requires service technician to troubleshoot.

USB Update Procedure

1. First, un-plug any communication cables from the holding bin. These devices will interfere with the timer bar boot loading process.
2. Place the update files on the USB flash drive in the main directory (Do not put them in a folder on the flash drive). There are five* files that you will need to put on the drive. Two for the controller board, **mainbin.hex** and **DHBFWBIN.TXT**. Three for the timer bars, **mainbar.hex**, **auxbar.hex** and **DHBFWBAR.TXT**.
3. Once all files are on USB drive, turn power off to bin and place the USB drive with the files into USB port on the front of the bin.
4. While holding down crown button on front right side of the bin, above the power switch, turn the power to the bin on.
5. Keeping the crown button pressed, wait for the “BL” (boot load) message to appear on the screen. Release the button approx. 5 seconds after the “BL” message appears or once the USB stick light begins to flash.
6. Wait for the display to show:
 - a. (blank while upgrading main bin firmware)
 - b. BL00 (searching for timer bars to upgrade)
 - c. BL02 (2 timer bars left to upgrade)
 - d. BL01 (1 timer bar left to upgrade)
 - e. BL00 (0 timer bars left to upgrade)
 - f. BN02 (2 timer bars detected and done with programming)
7. You can check the version number on the timer bars by pressing the Prince Castle logo button and the down button on timer bar.

*EHB34XX requires **seven** files. The two additional to those listed are **mainbar2.hex** and **auxbar2.hex**.

Dedicated Holding Bin

EHBTH34-1 Series



Wiring Diagram

NON-U.S., NON-CANADA, AND NON- BRAZIL ONLY

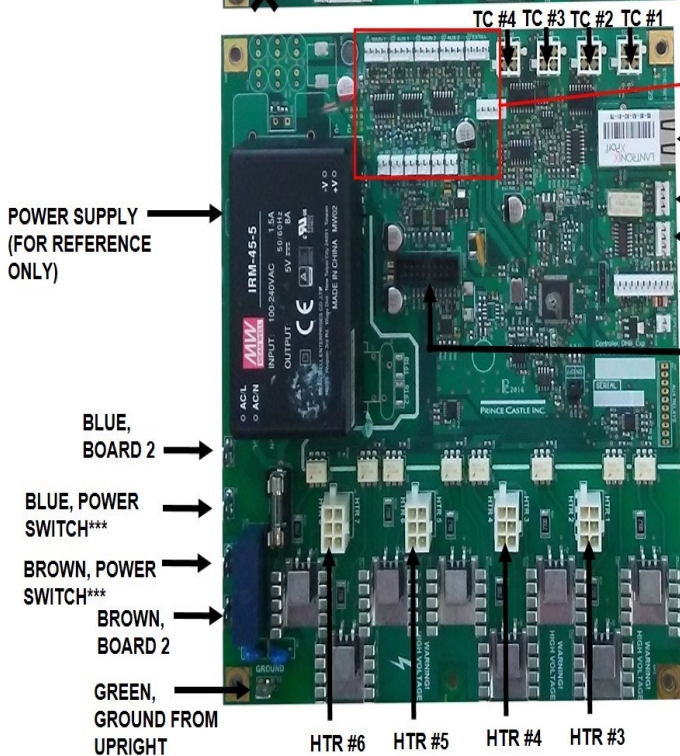
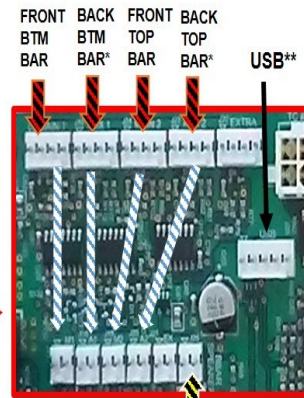
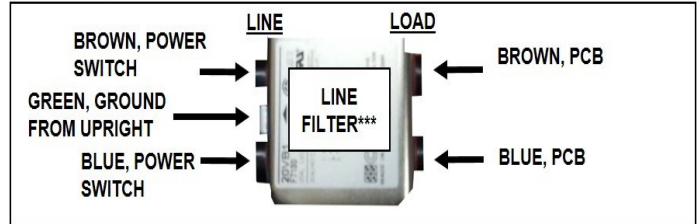
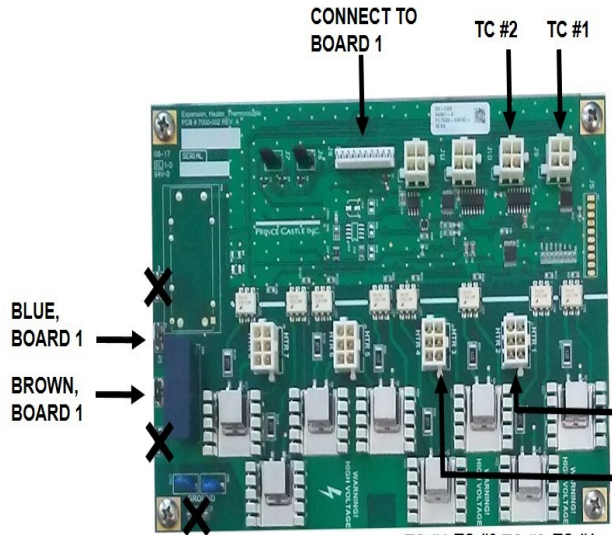

BOARD 2

BOARD 1

SPEAKER

KEY

- Braided wires, button bar (power)
- Braided wires, button bar (speaker)
- Braided wires, speaker
- Arrowhead = connector
- *Connections not used on some models
- **USB connector must be oriented with red wire toward power supply
- ***LINE FILTER if model is non-U.S., non-Canada, or non-Brazil

94-636_REV.D

Exploded View

Model	Power Cord
EHBTH34-1	72-476S

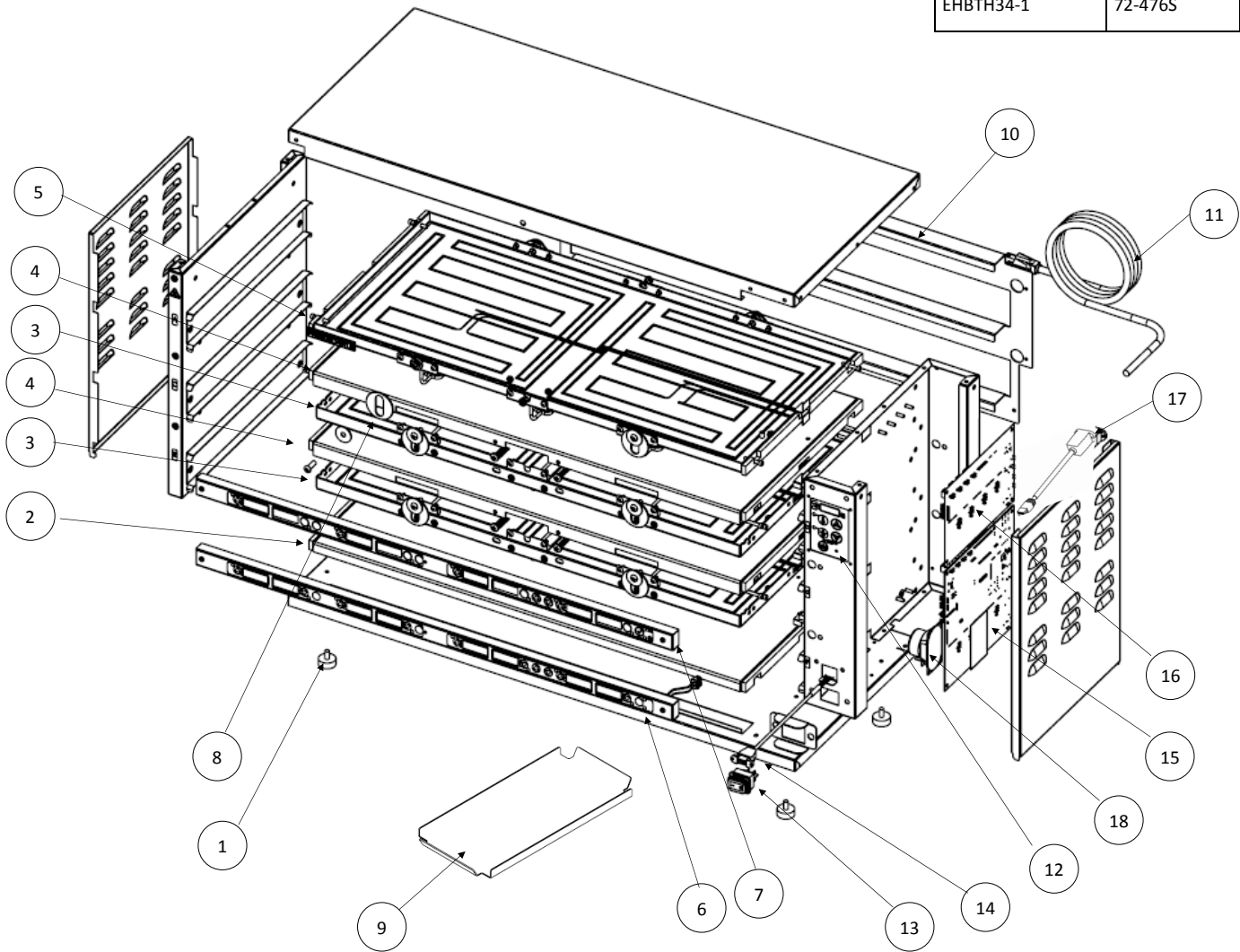

ITEM NO.	PART NUMBER	DESCRIPTION	ITEM NO.	PART NUMBER	DESCRIPTION	ITEM NO.	PART NUMBER	DESCRIPTION
1	197-232S	FOOT (4 PACK)	7	510-371S*	BB 8CH MAIN TOP	13	78-184S	POWER SWITCH
2	540-1072S	HTR, BOTTOM SHELF, LOWER	8	540-1158S	LATCH, CATCH	14	95-1819S	USB CORD
3	540-1226S	HTR, CENTER SHELF, LOWER	9	540-1251S	LID (4 PACK)	15	540-1425S*	BOARD 1
4	540-1224S	HTR, CENTER SHELF, UPPER	10	540-1412S	PAN STOP, 3x4	16	540-1426S*	BOARD 2
5	540-1222S	HTR, TOP SHELF, UPPER	11	USE TABLE	POWERCORD	17	95-2011S*	ETHERNET CONNECTOR
6	510-368S*	BB 8CH MAIN BASE	12	541-1394S*	OVERLAY, DISPLAY	18	88-709-2-11S	SPEAKER

*Recommended spares for stocking

Dedicated Holding Bin

EHBTH34-1 Series



REV	DATE	DESC.
A	1/9/19	RELEASE
B	7/1/20	ADDED NOTE TO INSTALLATION SECTION: "NOTICE – This product is not intended for connection to the residential public low-voltage supply system"