

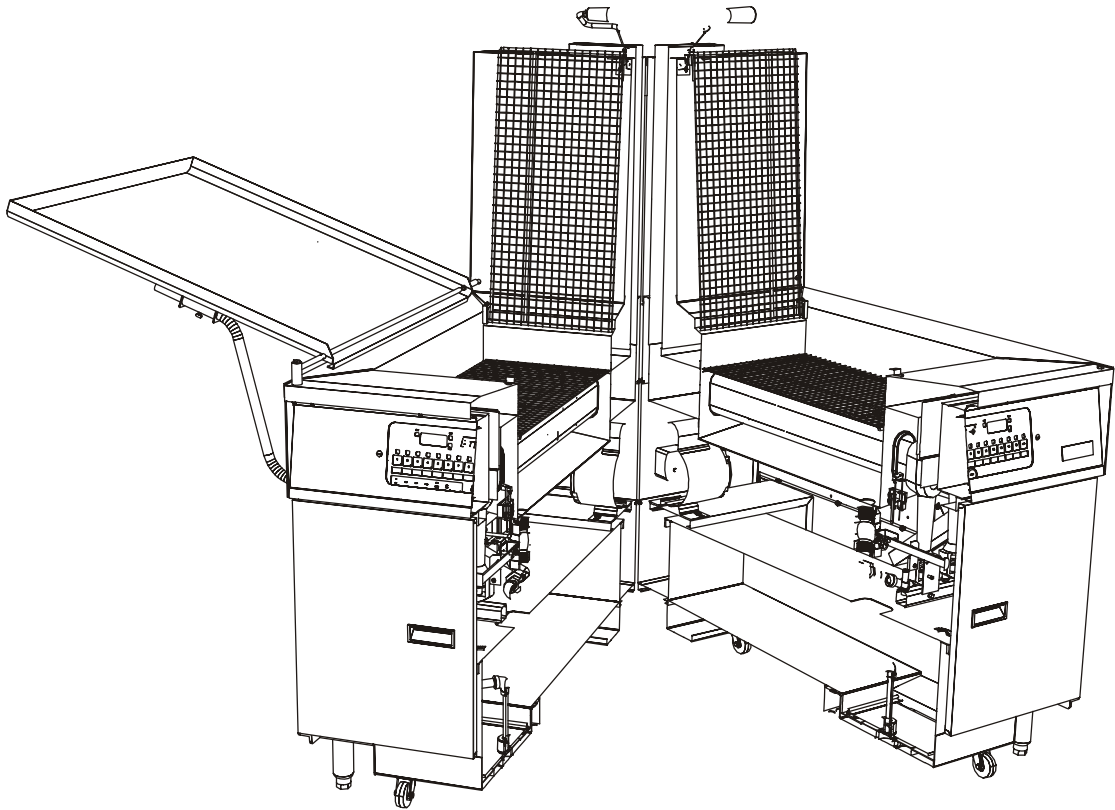

ENGLISH

Technical Service and Exploded Parts
For Gas Fryers
Covering Models
DD-24RUFM



THIS MANUAL MUST BE RETAINED FOR FUTURE REFERENCE

FOR YOUR SAFETY

DO NOT store or use gasoline or other flammable vapors or liquids in the vicinity of this or any other appliance.

WARNING

Improper installation, alteration, service or maintenance can cause property damage, injury or death. Read the installation, operating and maintenance instructions thoroughly before installing or servicing this equipment.

TO THE PURCHASER

Post in a prominent location the instructions to be followed in the event that an operator smells gas. Obtain this information from your local gas supplier.

WARNING

The fryer is equipped with an oil proof, electrical supply cord with a three prong safety plug. This is to protect operators from electrical shock hazard in the event of an equipment malfunction. **DO NOT** cut or remove the grounding (third) prong from this plug.

WARNING

There is an open flame inside the fryer. The unit may get hot enough to set near by materials on fire. Keep the area around the fryer free from combustibles.

WARNING

DO NOT supply the fryer with a gas that is not indicated on the data plate. If you need to convert the fryer to another type of fuel, contact your dealer.

WARNING

DO NOT use an open flame to check for gas leaks!

WARNING

Wait 5 minutes before attempting to relight the pilot to allow for any gas in the fryer to dissipate.

WARNING

Never melt blocks of shortening on top of the burner tubes. This will cause a fire, and void your warranty.

WARNING

Water and shortening **DO NOT** mix. Keep liquids away from hot shortening. Dropping liquid frozen food into the hot shortening will cause violent boiling.

WARNING

Ensure that the fryer can get enough air to keep the flame burning correctly. If the flame is starved for air, it can give off a dangerous carbon Monoxide gas. Carbon monoxide is a clear odorless gas that can cause suffocation.

WARNING

A cooker equipped with casters and a flexible gas line, must be connected to the gas supply with a quick disconnect device. This quick disconnect must comply with ANSI Z24.41. To limit the movement of the cooker without depending on the connector or quick disconnect, a restraining cable must also be installed.

WARNING

The power supply must be disconnected before servicing or cleaning the appliance

WARNING

Do not attempt to move the appliance when the unit is at operating temperature.
Hot oil will cause serious personal injury if it comes in contact with you skin

TROUBLESHOOTING

Figure 24 shows a block diagram for a unit with standing pilot ignition. Figures 26 and 27 are schematics for this type of fryer. On a fryer with standing pilot ignition, the pilot is lit by hand. The flow of gas is controlled by a valve called a “Unitrol” (V1). The Unitrol actually includes two separate valves - one for the pilot flame, and another valve for the main burners. When you turn the Unitrol handle to the Pilot position and push it in, the valve for the pilot burner opens. This allows you to light the pilot flame.

A device called a “thermopile” extends into the pilot flame. The thermopile generates a small electric current when it is heated. The Unitrol uses the current from the thermopile to keep the gas valve open. If the pilot goes out, the gas valve will close. This prevents the unit from leaking gas if the pilot goes out.

Once the pilot is burning, the main burners are controlled by a signal from the temperature control (A 1). When the temperature control calls for heat, it signals to the Unitrol, and the Unitrol turns on the gas supply for the main burners. A device called a “thermistor” (RT1) is used to sense the actual temperature in the kettle.

Other Circuits

This fryer has a built-in filtering system. The filter pump operates on 120V AC, and is controlled by a switch mounted on the control box panel.

The unit includes a high temperature limit switch (S3). This switch uses a sensor bulb which is mounted inside the fry kettle. When the temperature of the shortening rises above 450°F (232°C), this switch opens. On the version with standing pilot ignition, when the hi limit switch opens it causes the Unitrol to close, cutting off the gas supply to the fryer.

The pump will not be able to move the shortening if it has cooled and become solid. The filter pan has a 120V resistive heating element (HR1) which can be turned on by a switch behind the front door.

This fryer which includes a standard pilot and is wired for 120V AC has one transformer (T1). This transformer produces 24V AC for the computer on the front of the fryer. A 4 Amp slow-blow fuse protects the 24V AC output to the control circuit.

7. Drain switch. The controller will turn off if the drain valve is opened. If the controller will not turn on, make sure the drain valve is closed.

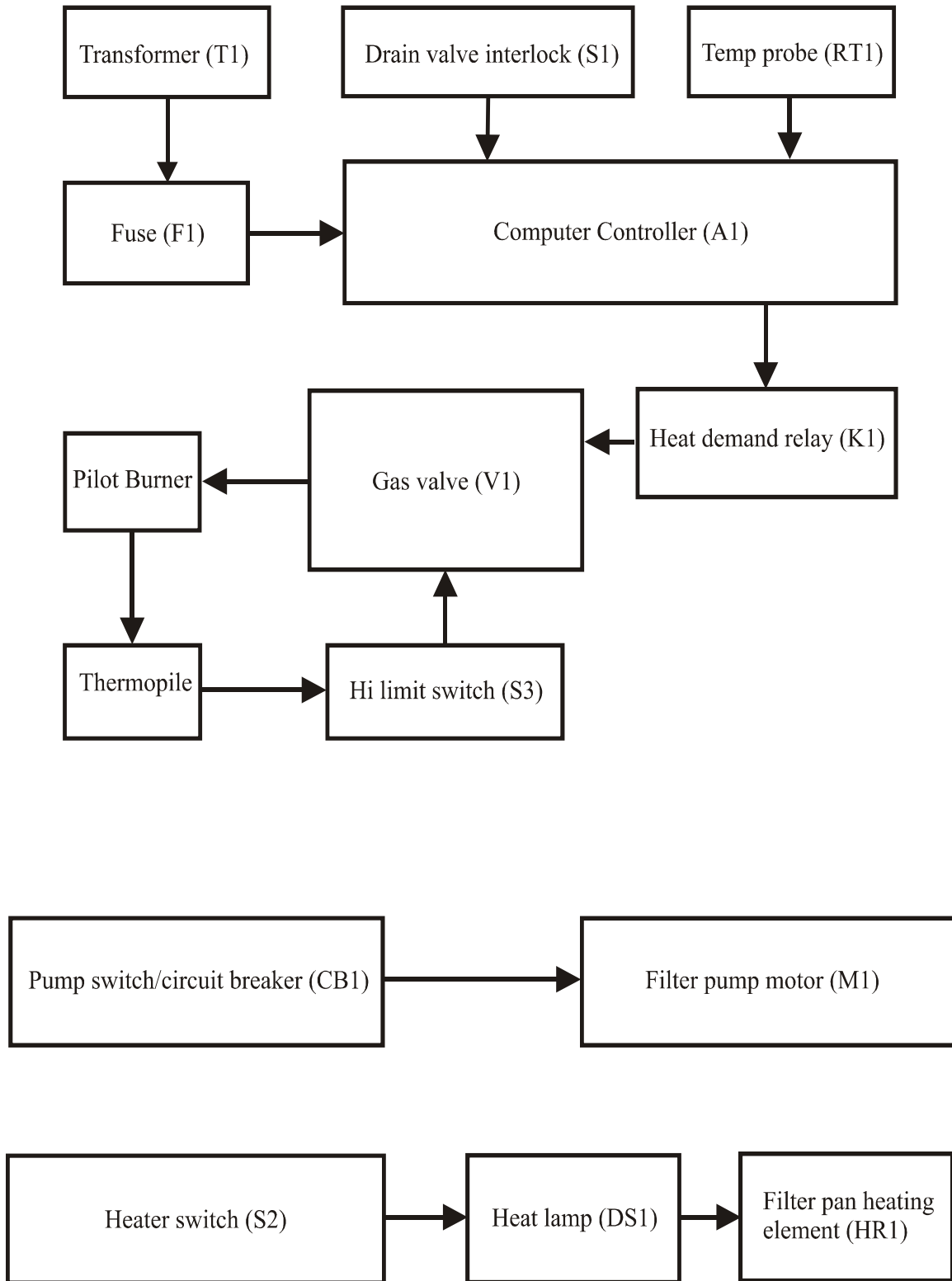

Fig.24
 Block diagram of control circuits
 Refer to Schematic 700341 for component identification.

PARTS LIST		
NOMENCLATURE	PART NO.	DESCRIPTION
A1	60138201	CONTROLLER, DUNKIN DONUTS
CB1	PP10460	CIRCUIT BREAKER, ROCKER SPST
DSI	PP10082	LAMP, 125V AMBER RECT
F1	P5045720	FUSE, 4A SLOW BLOW GLASS
F2	P5045721	FUSE, 7A SLOW BLOW GLASS
HR1	B6620302	FILTER, PLATE HEATER 120V
J8	P5046542	RECEPTACLE, TWIST LOCK 125V L5-15R
K1	PP11124	RELAY, 24VDC SPST
M1	P5046381	MOTOR, PUMP 115VAC
P8	P5046545	PLUG, TWIST LOCK 125V L5-15P
RT1	P5044876	PROBE, THERMISTOR
S1	PP10262	SWITCH, PROXIMITY SENSOR
	PP10263	SWITCH, PROXIMITY ACTUATOR
S2	PP11284	SWITCH, ROCKER DPDT
S3	PP10084	SWITCH, HIGH TEMPERATURE LIMIT
T1	PP10210	TRANSFORMER, 40 VA
V1	P5045650	VALVE, GAS UNITROL BMSER 120V NAT
	P5045652	VALVE, GAS UNITROL BMSER 120V LP

Fig 26 Schematic 700341

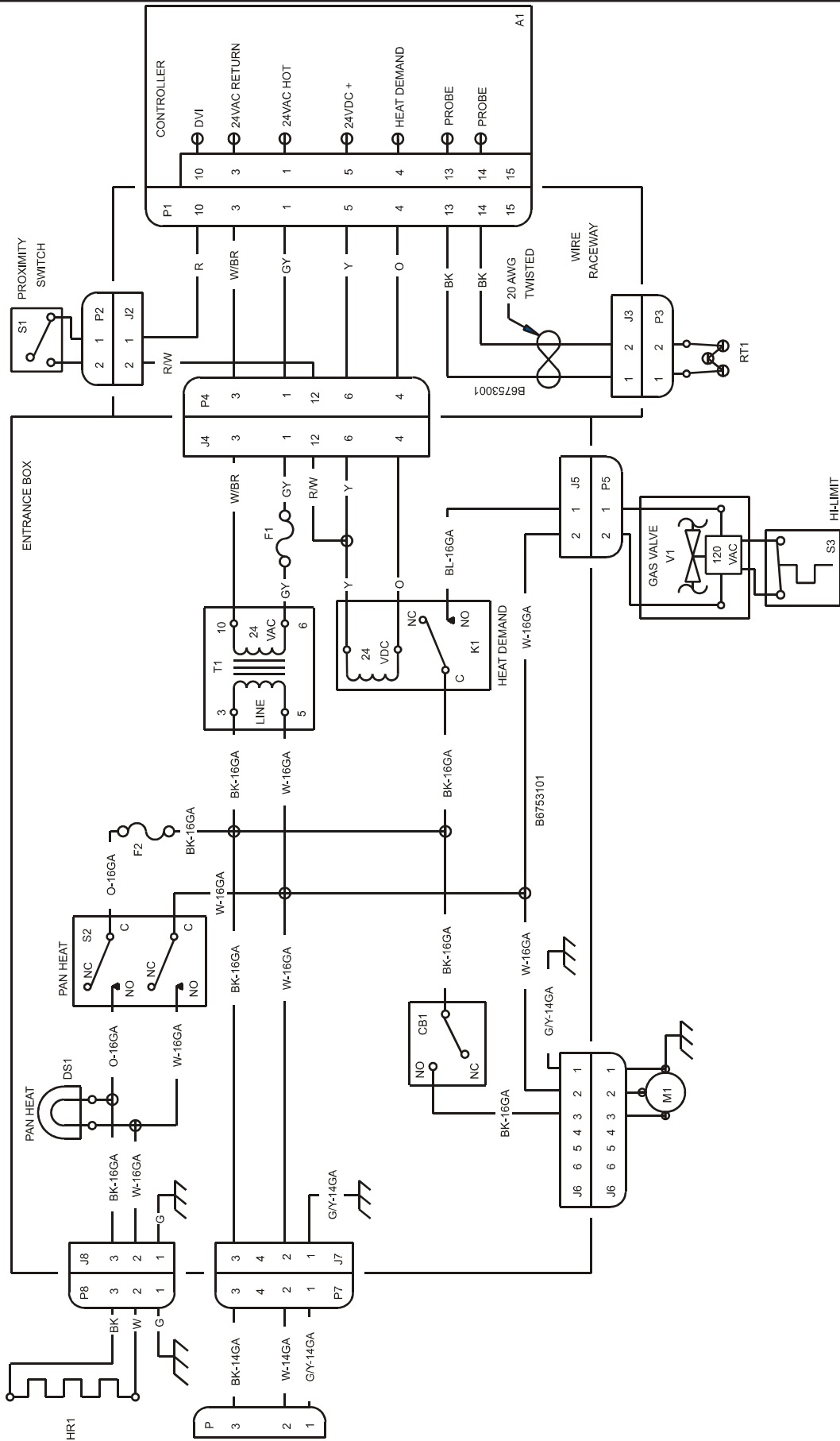

Fig 27 Schematic 700341

FRYER PROBLEM	CAUSE	CORRECTIVE ACTION
Computer does not come on; nothing shows in either display.	A. Main circuit breaker is turned off. B. Fryer fuse (F1) is blown	A. Locate the correct building circuit breaker, turn off and back on. B. Call an Authorized Service Technician
Computer heat light comes on but burners do not light.	A. Hi limit switch may be tripped. B. Pilot not lit C. Gas valve not in the on position	A. Allow oil to cool and reset the hi limit switch B. Light pilot C. Make sure pilot is lit and the gas valve is in the on position
Computer displays "OFF" and cannot be turned on	A. Drain valve open B. Drain valve switch loose C. Drain valve switch out of alignment D. Bad computer.	A. Close drain valve completely B. If mounting screws are loose, try to tighten C. Align switch or call Authorized Service Technician D. Locate the correct building circuit breaker, turn off and back on. If this does not reset the computer, call an Authorized Service Technician.
Computer displays "Prob"	A. Open or shorted temperature probe.	A. Call Authorized Service Technician to test and replace probe.

FILTER PROBLEM	CAUSE	CORRECTIVE ACTION
Filter pump not running with pump switch on	A. Main circuit breaker is turned off B. Circuit breaker/Pump switch (CB1) is open or in off position C. Defective pump motor	A. Locate the correct building circuit breaker, turn off and back on B. Turn off and back on C. If motor is getting 120V AC and does not run, call an Authorized Service Technician
Filter pumps slowly and/or blows air bubbles into to oil. Four to five minutes to fill tank	A. Defective filter connections B. Blocked filter paper C. Bad pump D. Intake hose leaking	A. Replace filter connections if air bubbles are in the oil being returned to the vat B. Change the filter paper C. Call Authorized Service Technician D. Call Authorized Service Technician
Heater in filter pan will not heat. Pan heat light (DS1) is not on when heater ON/OFF switch (S2) is in the on position	A. Main circuit breaker is turned off B. F2 fuse is blown C. Defective pan heat switch	A. Locate the correct building circuit breaker, turn off and back on B. Replace fuse, why did fuse blow? C. Replace switch
Heater in filter pan will not heat. Pan heat light is on when heater on/off switch is on.	A. Pan heater not plugged in B. Defective pan heater	A. Plug in pan heater cord to entrance box B. Check the resistance through the heating element. You should see a resistance of approximately 36 ohms.

Testing a Transformer (T1)

Check the voltage input and output on the transformer when the fryer is turned on. When there is 120V AC at the input (term 3 & 5), you should see 24V AC at the output (term 6 & 10). If do not see the correct output, replace the transformer. You can also use an Ohmmeter to check for continuity through the transformer coils. Be sure neither of the coils is shorted to the frame of the transformer.

Testing the Temperature Control Module (A1)

The output from the temperature control module is found on terminal 5. If the controller does not produce 24VAC output on terminal 5 when the controller is calling for heat, replace the module.

Testing the thermistor (RT1)

A “thermistor” is a special kind of resistor. The resistance of this part goes down as it is heated. The table below shows the correct resistances at different temperatures. If the thermistor shows an open circuit, or if it shows the wrong resistances at these temperatures, replace it.

75°F = 95,539Ω	250°F = 3,458Ω
100°F = 53,146Ω	300°F = 1,734Ω
150°F = 18,695Ω	350°F = 942Ω
200°F = 7,586Ω	400°F = 547Ω

Testing the Hi Limit Switch (S3)

Press the red reset button. Check the switch for continuity, you should have continuity across the switch. You should not have continuity to ground.

Testing Drain Valve Interlock (S1)

With the drain valve closed, you should have continuity through the switch. You should not have continuity to ground.

Testing Heat Demand Relay (K1)

Check the resistance across the coil with the coil wires off. You should see a resistance of approximately 650 ohms. With 24 volts DC at the coil, you should have continuity across the COM and NO terminals. Without 24 volts DC at the coil, you should have continuity across the COM and NC terminals.

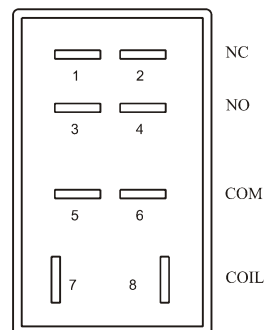

Testing Gas Valve (V1)

Pitco Frialator DD 24R-UFM Doughnut Fryer

Check the resistance through the gas valve. You should see a resistance of approximately 2350 ohms across the coil of the valve.

Testing Filter Pan Heaters (HR1)

Check the resistance through the heating element. You should see a resistance of approximately 36 ohms in the element

Pitco Frialator DD 24R-UFM Doughnut Fryer

Item #	Part #	Part Description
1	P7036013	Reducer Bushing, 3/4 X 1/2
2	P7038050	1/2" Lock Nut
3	P7036902	1/2" Union
4	P7037090	1/2" Close Nipple
5	P7037750	1/2" Street Elbow
6	P5045650	Gas Valve, Nat 120V
	P5045652	Gas Valve, LP 120V
7	P7037096	1/2" X 3 1/2" Nipple
8	P7037678	1/2" Elbow
9	P7037093	1/2" X 2" Nipple
10	PP10084	Hi Limit Switch
	A1815501	Hi Limit Bracket
	B6779850	Hi Limit Wires
	P0007300	Screw, 8-32 X 1/2
	PP10687	Screw, 6-32 X 5/16
11	A7575101	Pilot Tube
12	P6071450	Pilot Assembly
13	P5047541	Thermopile
14	PP11261	Bolt, 5/16 X 3/4
15	P6071050	4" Burner
16	A8001001	Air Collar
	PP10025	Screw, 10-32 X 1/4
17	A1325201	Right Manifold Bracket
	A1325203	Left Manifold Bracket
18	P6071347	Orifice Tip #47 Nat
	P6071353	Orifice Tip #53 LP
19	B8019801	Gas Manifold
20	A3701009	Heat Sheild
21	PP10818	1/2" X 28 3/4" Nipple

Table 1

Pitco Frialator DD 24R-UFM Doughnut Fryer

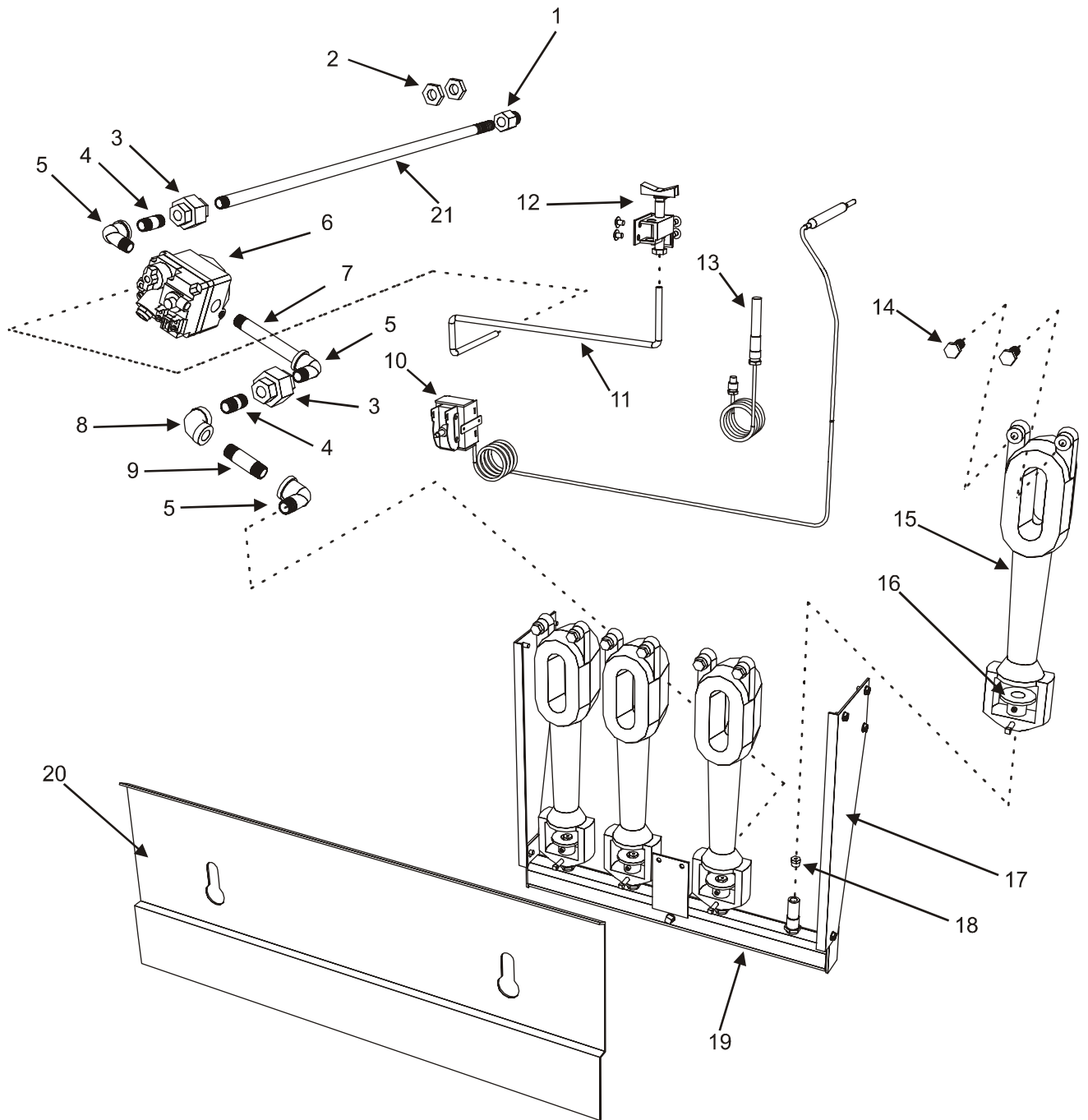

Figure 1

Pitco Frialator DD 24R-UFM Doughnut Fryer

Item #	Part #	Part Description
1	PP11124	24VDC Relay
2	PP10210	40VA Transformer
3	PP11284	Rocker Switch DPDT
4	PP10082	Lamp, 125V
5	P5046542	Twist Receptacle
6	P5045794	Fuse Holder
7	PP10460	8 Amp Circuit Breaker
8	A2959401	Entrance Box Cover
9	B6753101	Entrance Box Harness
10	B6753001	Raceway Wiring
11	B6701401	Power Cord
8 - 11 Not Shown		

Table 2

Pitco Frialator DD 24R-UFM Doughnut Fryer

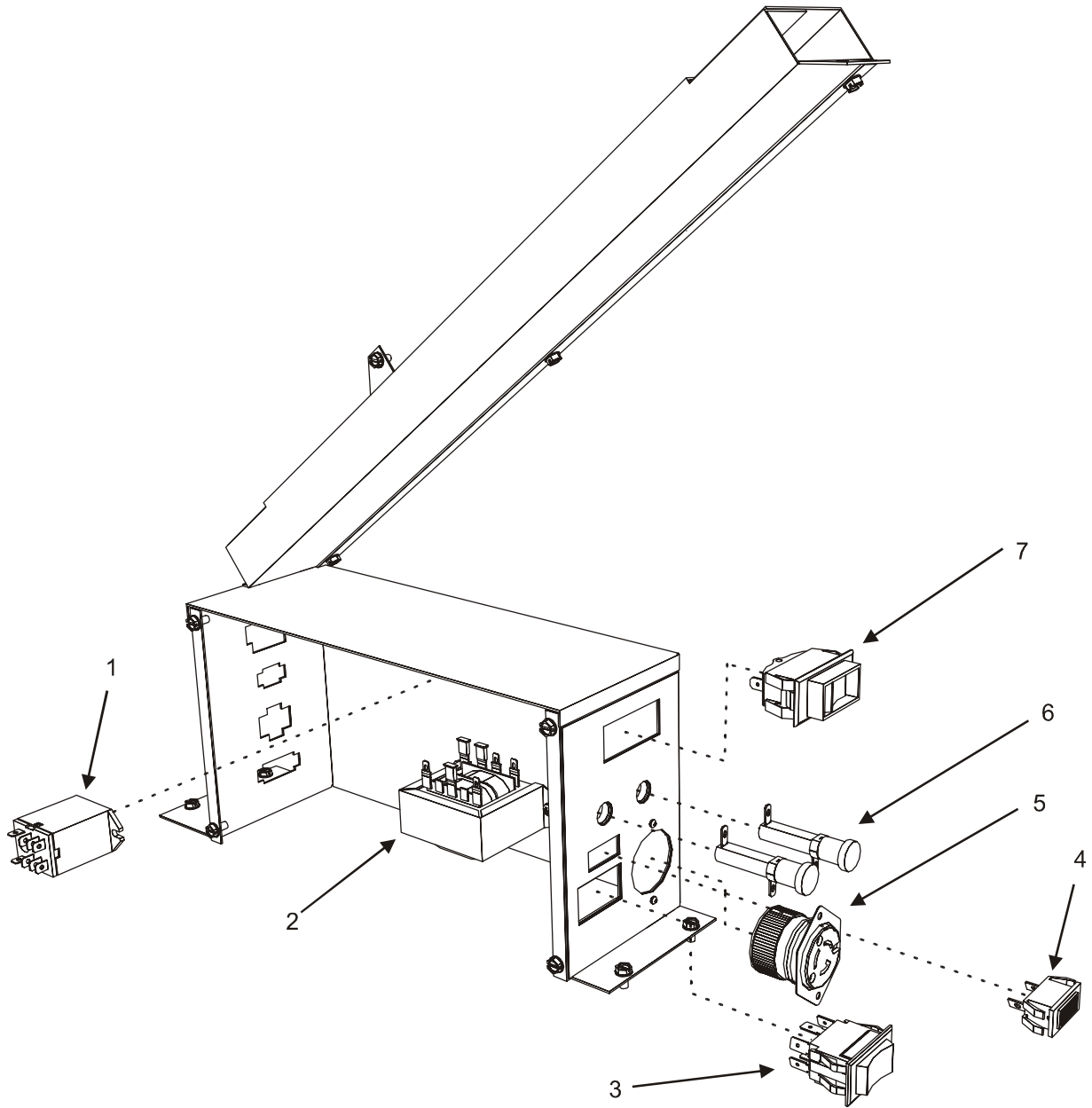

Figure 2

Pitco Frialator DD 24R-UFM Doughnut Fryer

Item #	Part #	Part Description
1	P0079500	Screw, 10-24 X 1/2
2	A4103301	Splash Back Lug
3	A4103202	Secondary Submerger Catch
	A4510902	Submerger Catch
4	PP10698	Screw, 10-24 X 5/8
	B2400304	Drainboard Assembly (items 5-12)
5	A2402101	Drainboard Spacer Rod
6	B2400504	Drainboard Weldment
7	A2401001	Drainboard Stop Tubing
8	PP10065	Thumb Screw, 1/4-20 X 3/4
9	A2401101-1	Drainboard Support Tubing
	P6071492	5/8" Hole Plug
10	B2400202	Drainboard Hinge Rod
11	P0026400	Bolt, 3/8-16 X 2 1/2
12	P5045165	Rubber Tip
13	B4506824	Submerger Screen
14	PP10698	Screw, 10-24 X 5/8
15	B4507501	Submerger Handle
16	P6071190	Plastic Handle
17	P0095200	Jam Nut
18	P0142000	Acorn Nut
19	PP11366	Screw, 10-24 X 5/8
20	A4106802	Hi Limit Bulb/Probe Clamp
21	P6072402	Tube Screen
22	B4100208	Splash Back Weldment
	A4100201	Splash Back Cover
<u>Complete Assemblies</u>		
B2400304		Drainboard Assembly (includes 5-12)
B4507401		Submerger Screen Assmby (includes 13-18)
B4507001		Submerger Handle Assembly (includes 14-18)

Table 3

Pitco Frialator DD 24R-UFM Doughnut Fryer

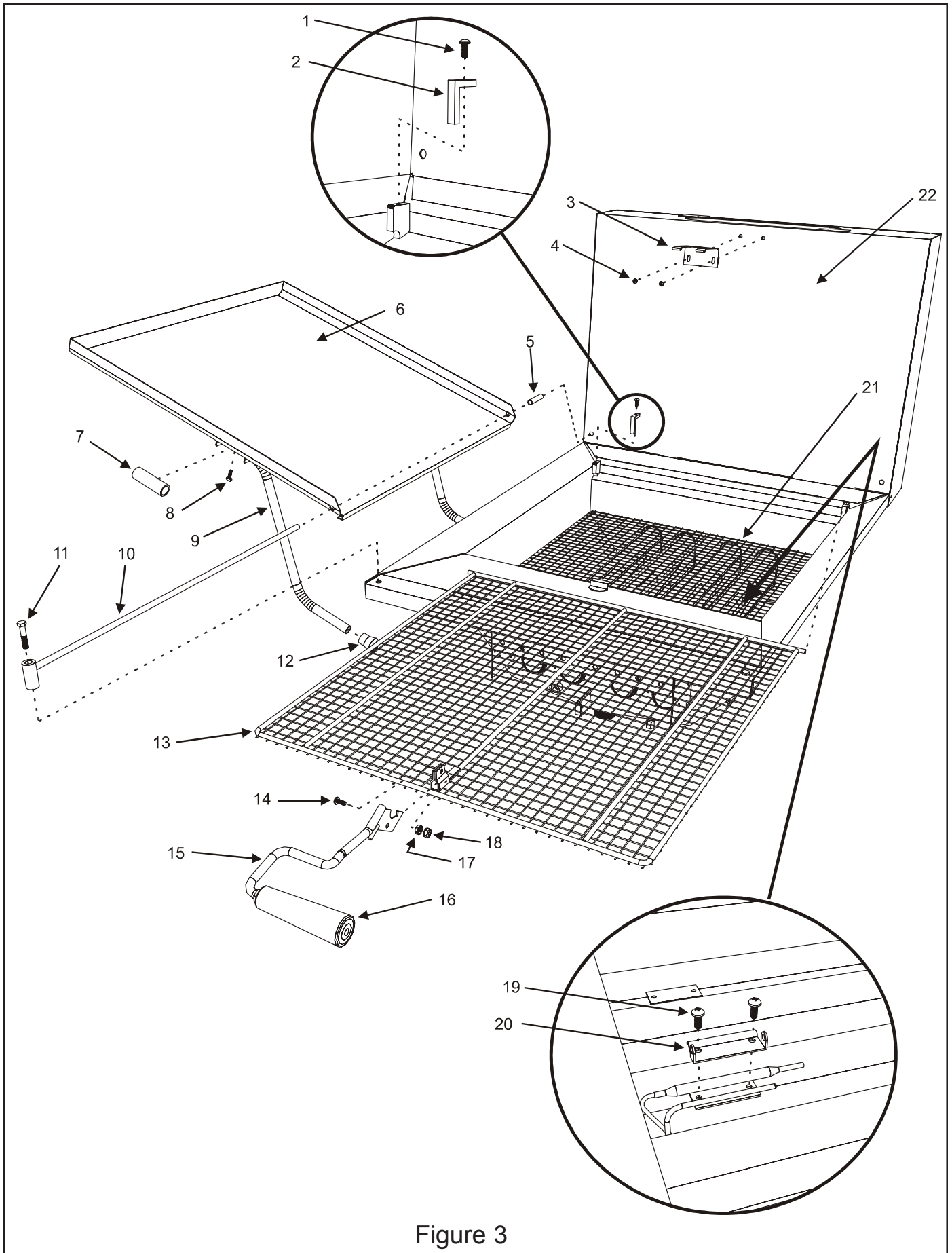

Figure 3

Pitco Frialator DD 24R-UFM Doughnut Fryer

Item #	Part #	Part Description
1	B3500801	Flue Pipe Weldment
2	B3306202-C	24R Stainless Steel Tank
	B3306201-C	24R Cold Rolled Steel Tank
3	B1824601	Cabinet Assembly
4	A3671502	Lower Front Panel
5	A3671402	LH Front Panel End Cap
6	P0092300	10-24 Kep Nut
7	60138201	DD Computer
8	A3671602	Front Panel Bezel
9	60125801	Screw, 10-24 X 3/8
10	B2304604	24R Door Assembly
11	B3802404	Upper Left Hinge
12	B3801804	Lower Left Hinge
13	B3801803	Lower Right Hinge
14	PP11006	Door Handle
15	B3802403	Upper Right Hinge
16	B3900701	Leg Set
17	A3671404	RH Front Panel End Cap
18	P6071300	Door Magnet Catch

Table 4

Pitco Frialator DD 24R-UFM Doughnut Fryer

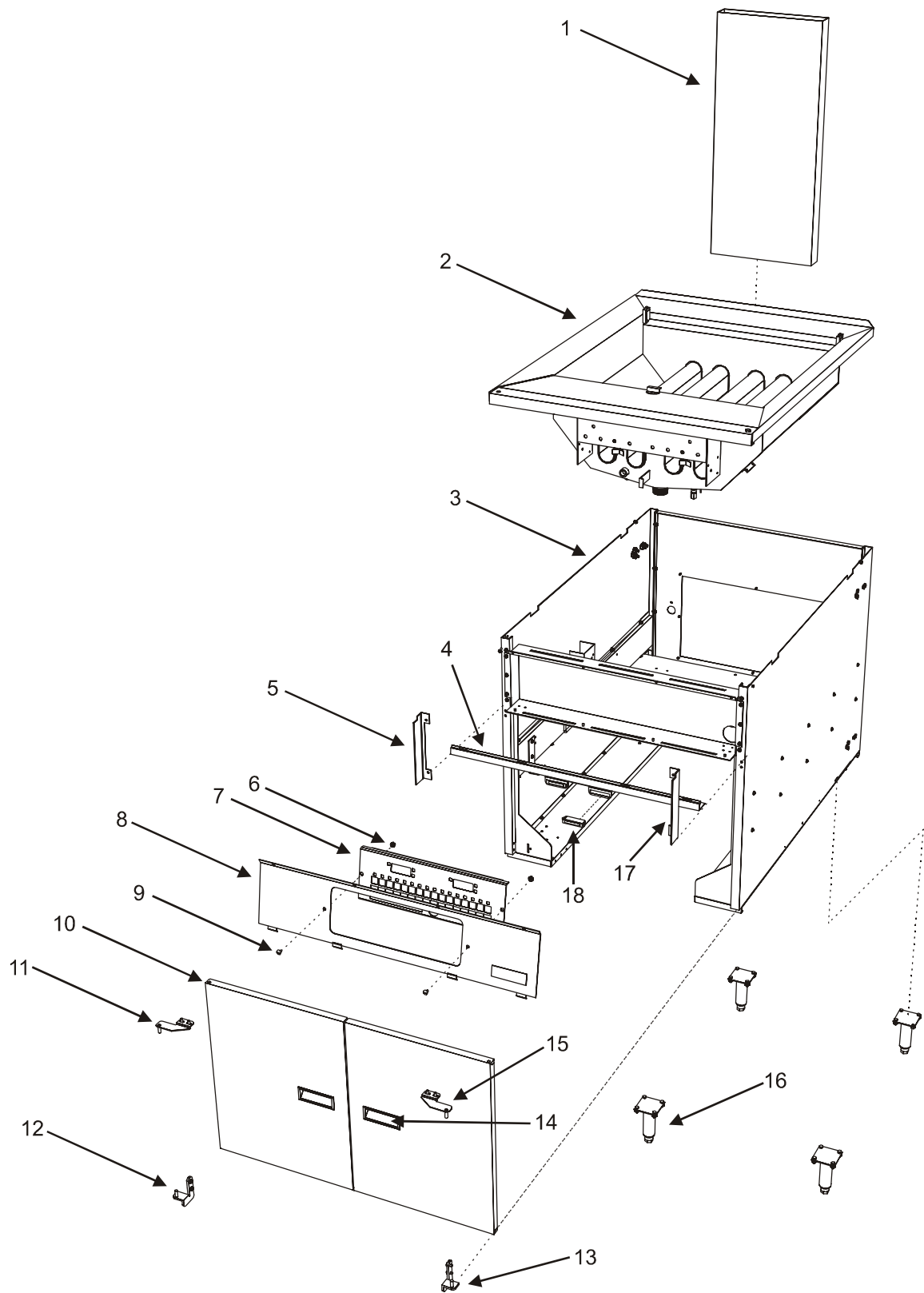

Figure 4

Pitco Frialator DD 24R-UFM Doughnut Fryer

Item #	Part #	Part Description
1	A6627702	Filter Pan Cover
2	P6071516	Chrome Handle
3	P0007300	Screw, 8-32 X 1/4
4	P6071123	3/8 Male Connector Nipple
5	P7037308	3/8 X 4 Nipple
6	P7037675	3/8 Elbow
7	P7037309	3/8 X Nipple
8	A6682202	Filter Paper Support Rack
	PP10617	Filter Paper 11 X 13
9	P6071526	Top & Bottom Plate
10	P7037313	3/8 X Nipple
11	A6615802	Filter Paper Retainer Clip
12	B6606801	Filter Pan Weldment
	B6606901	Filter Carriage Assembly
	A6668902	Heater Plate Cover
13	B6620302	Filter Plate Heater
14	B6635801	Filter Electrical Box
	P5046545	Twist Lock Plug
	PP10452	Power Cord
	P5045090	3/4" Snap Bushing
	P5046220	Stain Relief Bushing
	P5045432	2X4 Box Cover
15	B6606701	Filter Carriage Weldment
16	P6071062	2" Caster
17	P0011300	Screw, 10-24 X 3/8
	P0092300	10-24 Kep Nut
	<u>Complete Assemblies</u>	
B661401		Filter Pan Cover Assembly (inc. 1-3)

Table 5

Pitco Frialator DD 24R-UFM Doughnut Fryer

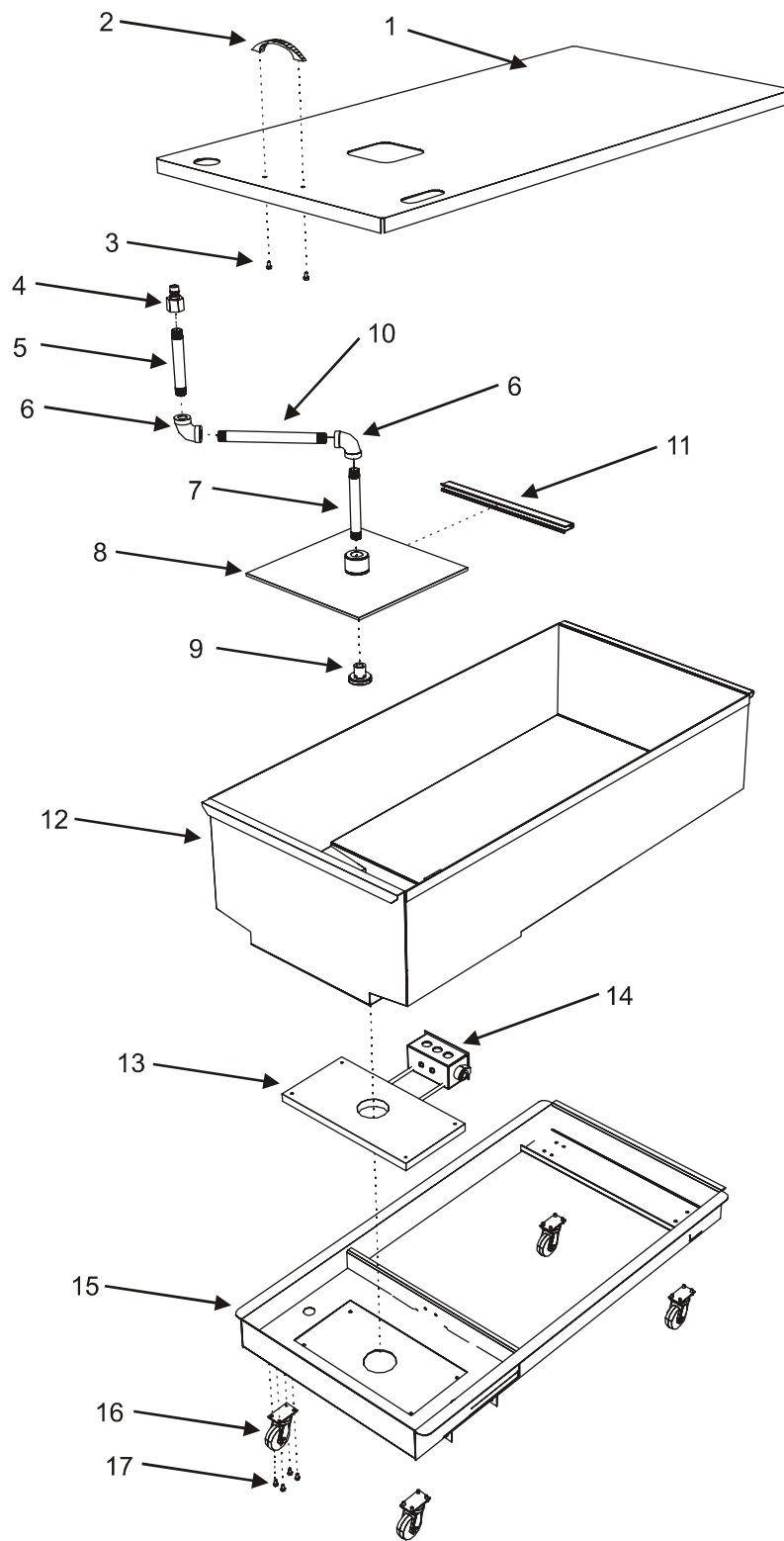

Figure 5

Pitco Frialator DD 24R-UFM Doughnut Fryer

Item #	Part #	Part Description
1	B7402241-C	Black Donut Assembly
2	P7037301	3/8 Close Nipple
3	P6071780	3/8 Ball Valve
	PP10050	3/8 Return Valve Handle
4	P7037752	3/8 Street Elbow
5	P7036854	3/8 Tee
6	P7037300	3/8 Space Nipple
7	P7036600	3/8 NPT Coupling
8	P7037330	3/8 X 16 Nipple
9	P7037675	3/8 Elbow
10	P7037305	3/8 X 2 1/2 Nipple
11	P7036901	3/8 Union
12	P7036014	1/2 X 3/8 Reducer Bushing
13	P5046381	.5HP Pump & Motor
	P5046384	.5HP Motor Only
	P6071530	Pump Only
14	P7037308	3/8 X 4 Nipple
15	P7037093	1/2 X 2 Nipple
16	P7036902	1/2 Union
17	A6653510	31-3/4 Filter Return Hose
18	B7402240-C	White Donut Assembly
		Flush Hose Not Shown
	B6602501	Filter Flush Hose Assembly
	A6653505	Flush Hose
	B6661001	Flush Hose Nozzle
	P6071123	3/8 Male Connector Nipple
	P7037752-1	3/8 Street Elbow

Table 6

Pitco Frialator DD 24R-UFM Doughnut Fryer

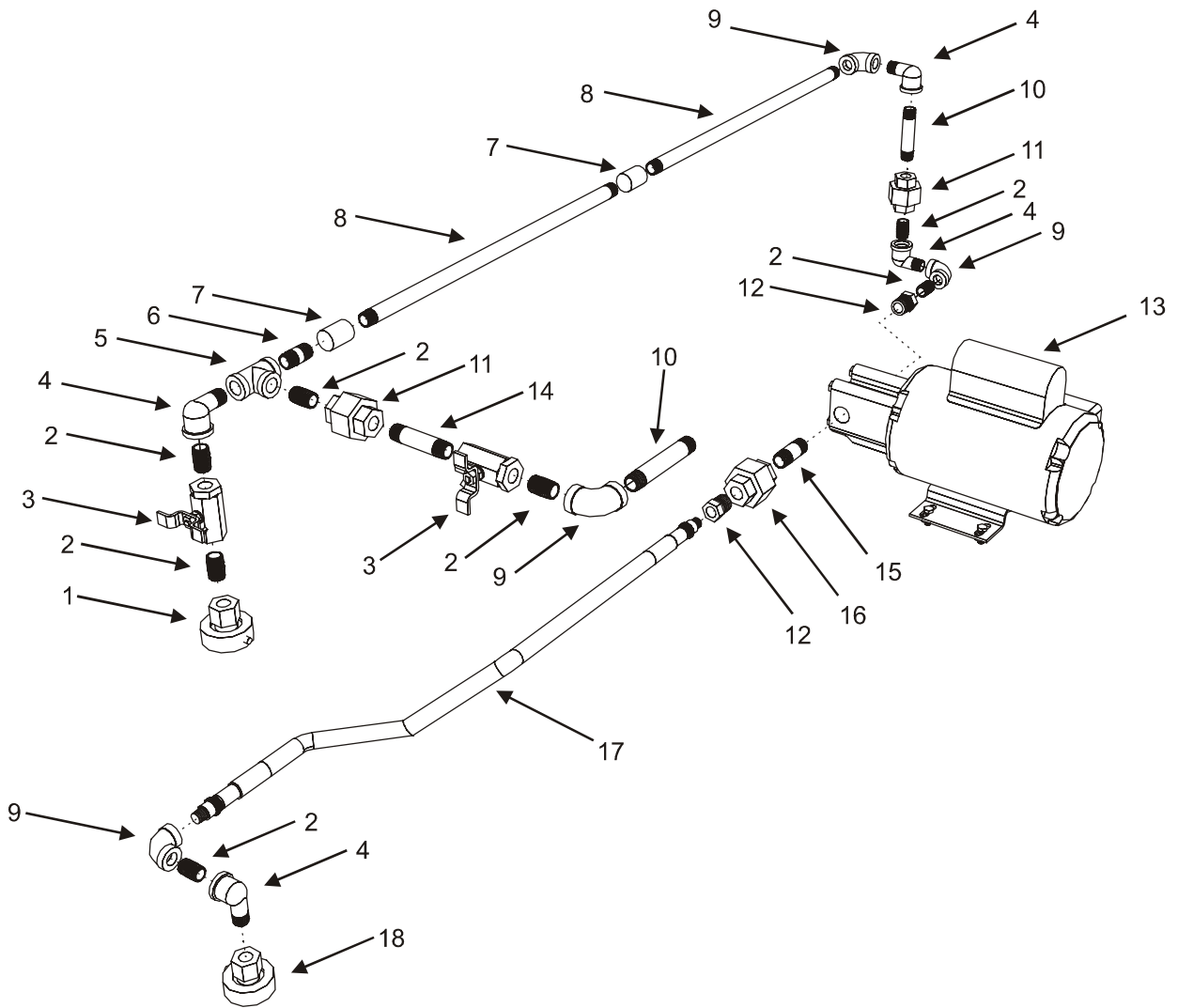

Figure 6

Pitco Frialator DD 24R-UFM Doughnut Fryer

Item #	Part #	Part Description
1	PP10266	Screw, 4-40 X .25
2	A4021601	Handle Actuator Bracket
3	PP10263	Proximity Switch Magnet
4	B5305001	DVI Electric Assembly
5	A4011101	Dain Valve Handle Support
6	B4000801	Drain Valve Handle
7	PP10023	Screw, 10-24 X 3/8
8	PP10699	Screw, 10-24 X 3/4
9	P0092300	10-24 Kep Nut
10	A4021301	Drain Valve DVI Bracket
11	A4021204	Drain Valve Handle Bracket
12	P0190145	Cleavis Pin
13	P0190300	Cotter Pin
14	PP10368	Drain Valve

Table 7

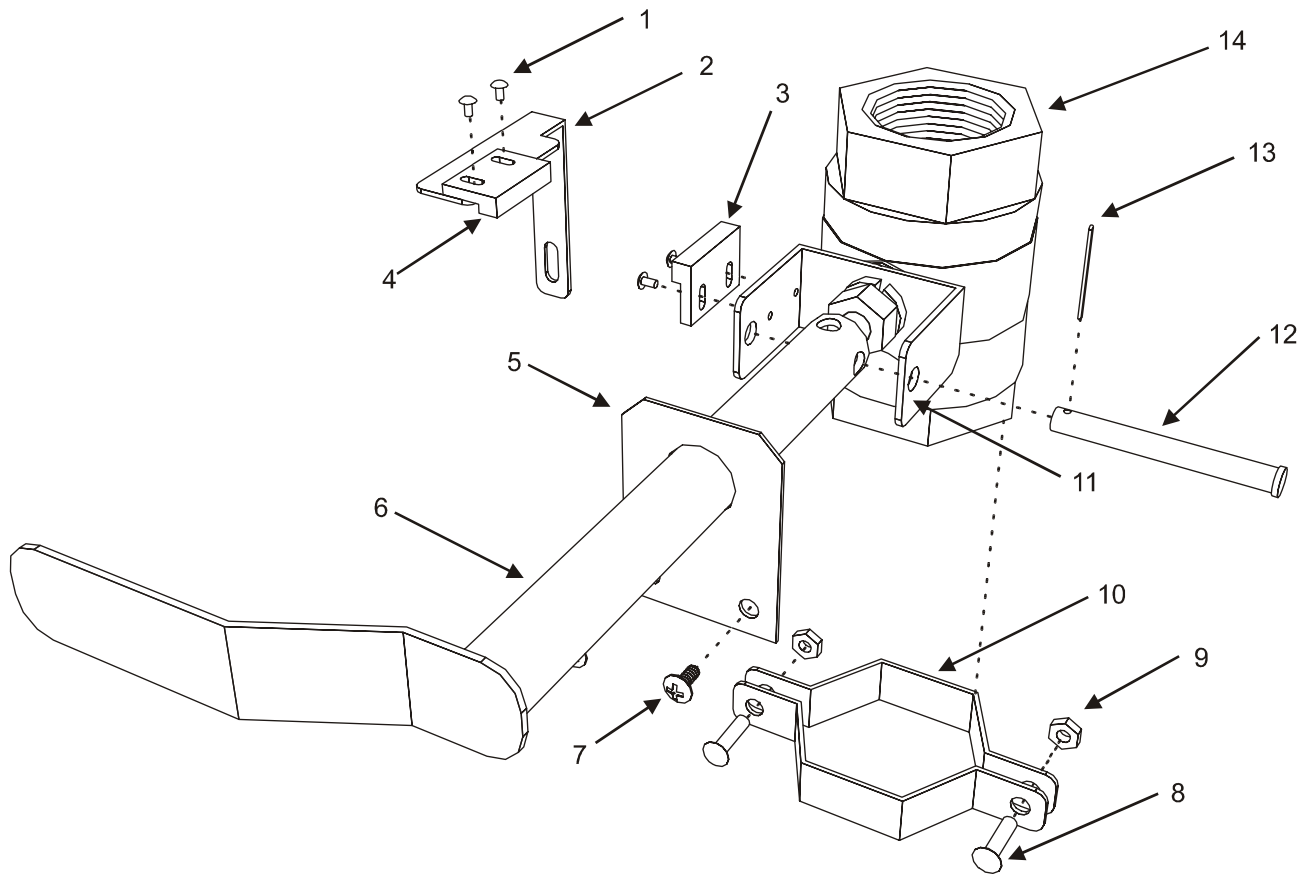
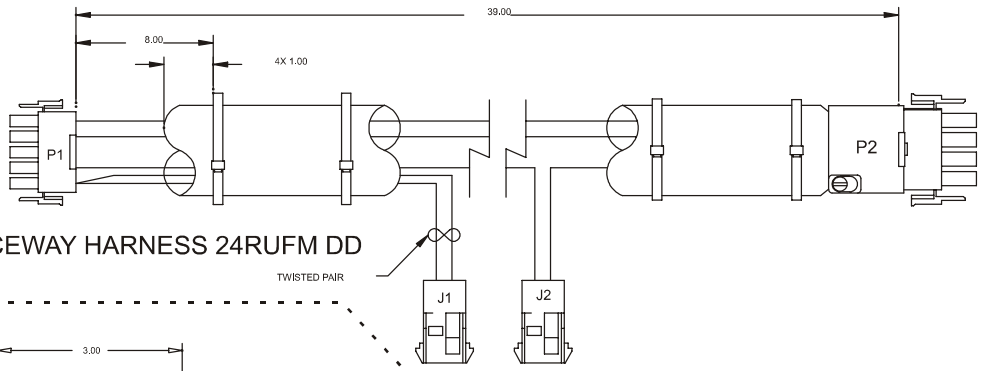

Figure 7

Pitco Frialator DD 24R-UFM Doughnut Fryer

Harnesses not shown
 B6701401, POWER CORD
 B6706901, MOTOR CORD



B6753001, RACEWAY HARNESS 24RUFM DD

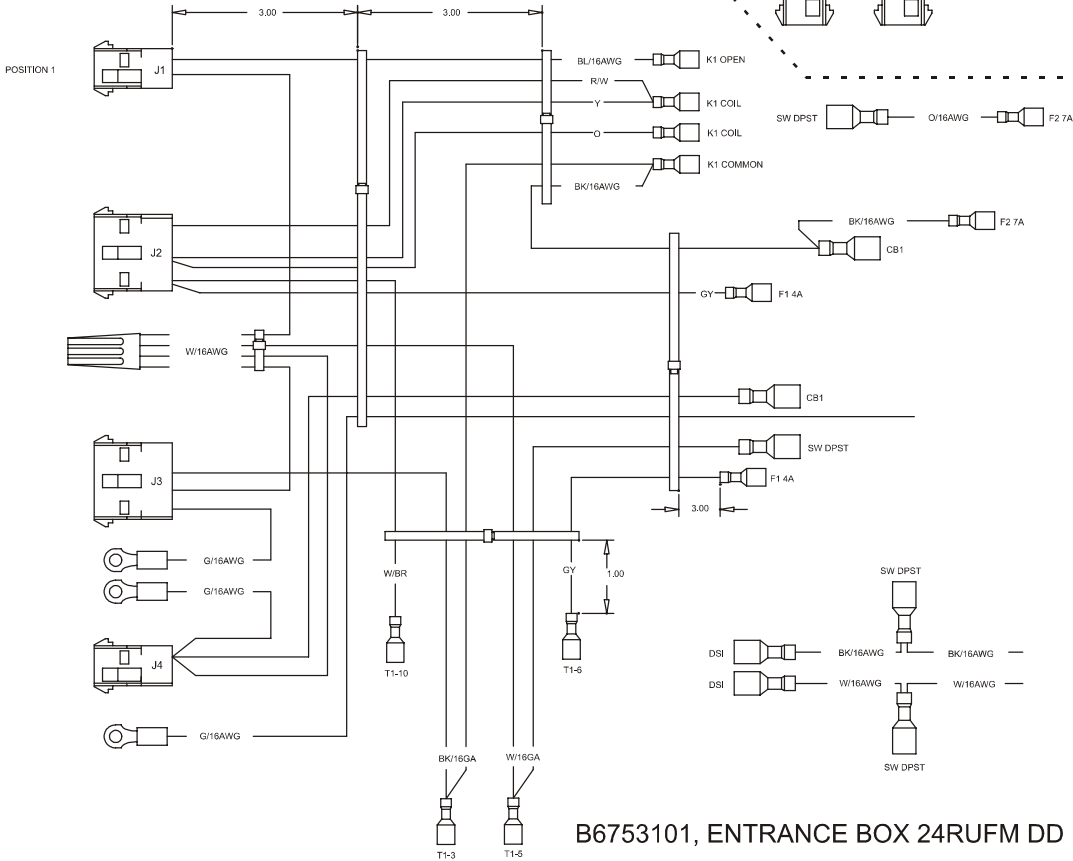

B6753101, ENTRANCE BOX 24RUFM DD

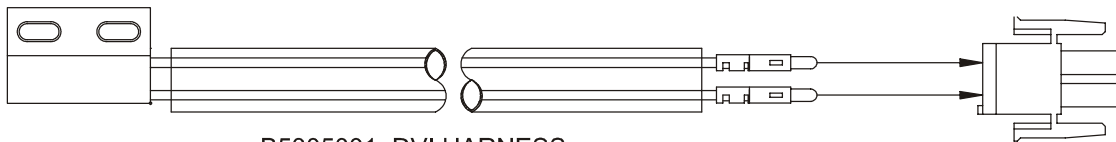

B5305001, DVI HARNESS

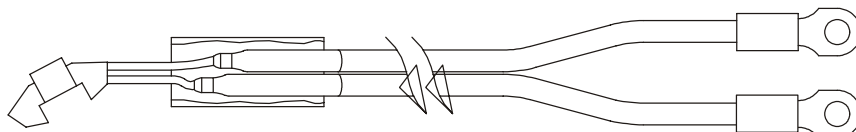

B6779850, HI LIMIT HARNESS

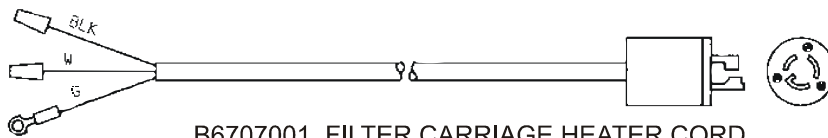

B6707001, FILTER CARRIAGE HEATER CORD



In the event of problems with or questions about your order, please contact the Pitco Frialator factory, from 8:00 a.m. - 5:00 p.m., Eastern Standard Time, Monday through Friday, toll-free at:

(800) 258-3708 US and Canada only or
(603) 225-6680

In the event of problems with or questions about your order, please contact the Pitco Frialator Authorized Service and Parts representative (ASAP) covering your area, through Pitco at:

(800) 258-3708 US only, 24 hours