

**CRISP N' HOLD**  
**FOOD HOLDING STATION**  
Free-Standing Floor MODELS: PCF14, PCF18  
**OWNERS / OPERATORS MANUAL**



**PCF18**  
**(shown)**

**TABLE OF CONTENTS**

SAFETY PRECAUTIONS.....	2
FEATURES & SPECIFICATIONS.....	3
UNPACKING AND INSPECTION.....	4
INSTALLATION & START-UP.....	5
NORMAL OPERATION .....	6
CONTROLLER PROGRAMMING.....	6
DAILY CLEANING PROCEDURES.....	7
WIRING DIAGRAMS & REPLACEMENT PARTS.....	8
TROUBLESHOOTING GUIDE .....	9
WARRANTY STATEMENT.....	10

Part Number: L20-354 Rev 2 (05/12)

Printed in The United States of America

## SAFETY PRECAUTIONS



### WARNING: ELECTRIC SHOCK HAZARD

All service requiring access to non-insulated components must be performed by qualified service personnel. Failure to heed this warning may result in severe electric shock.



### CAUTION: ELECTRIC SHOCK HAZARD

Disconnect this appliance from electrical power before performing any maintenance or service.



### CAUTION: BURN HAZARD

Exposed metal surfaces can be hot to the touch and may cause burns.

## IMPORTANT SAFETY INSTRUCTIONS

When using electrical appliances basic safety precautions should be adhered to, including the following:

- 1) Be familiar with the appliance use, limitations and associated restrictions. Operating instructions must be read and understood by all persons using or installing this appliance.
- 2) This appliance must be grounded. Connect only to properly grounded outlet.
- 3) Use this appliance only for its intended use as described in the manual.
  - a. This equipment is specifically designed to hold pre-cooked food at temperature.
  - b. This equipment is intended for use in commercial establishments only.
  - c. This equipment is not designed for industrial or laboratory use.
- 4) Cleanliness of this appliance and accessories is essential to good sanitation.
- 5) DO NOT submerge this appliance in water. This appliance is not jet stream approved. DO NOT direct water jet or steam jet at this appliance, or at any control panel or wiring. DO NOT splash or pour water on, in or over any controls, control panel or wiring. DO NOT use corrosive chemicals or vapors in this appliance.
- 6) DO NOT store this appliance outdoors. DO NOT use this product near water – for example, near a kitchen sink, in a wet basement, or near a swimming pool, and the like.
- 7) DO NOT operate this appliance if it has a damaged cord or plug, if it is not working properly, or if it has been damaged or dropped. Do not immerse cord or plug in water, keep cord away from heated surfaces, and do not let cord hang over edge of table or counter.
- 8) **Only qualified service personnel should service this appliance.**
- 9) DO NOT cover or block any openings on the appliance.

### NOTE:

The technical content of this manual, including any wiring diagrams, schematics, parts breakdown illustrations and/or adjustment procedures, is **intended for use by qualified technical personnel** and is subject to change without notice.

## FEATURES & SPECIFICATIONS

### Free-Standing Forced Convection Food Holding Cabinets

The Crisp n' Hold provides a heated stream of air to maintain fried food temperature and freshness for a specified period of time after cooking. Forced air is heated through an electric resistance heater and ducted to a food grate. The heated air is discharged through small circular openings in the bottom of the grate and through a slotted opening located front top to provide a warm blanket of air over the food. Additionally, the grate has small round embossments to minimize hot metal contact with the food. The PCF14 & PCF18 are free-standing floor models on casters, so they can be moved for convenience and cleaning. Swivel front casters have brakes. Controls are located in the cabinet below the warmer for easy access.

### Capacity/Dimensional Characteristics

**Layout: Two models, with adjustable and removable dividers:**  
14" with 2 sections; 18" with 3 sections

#### Internal Capacity (cubic inches):

PCF14	837	2 sections
PCF18	1050	3 sections

#### Overall Dimensions inches (mm):

PCF14	45.5"H x 34.5"D x 15.5"W (1156H x 876D x 394D)
PCF18	45.5"H x 34.5"D x 19.6"W (1156H x 876D x 498D)

#### Shipping Weight lbs (kg):

PCF14	132 (60)
PCF18	145 (66)

Agency Approvals



### Electrical Characteristics

<b>Model:</b>	<b>PCF14 &amp; PCF18</b>
<b>Watts:</b>	<b>1820</b>
<b>Voltage:</b>	<b>120</b>
<b>Phase:</b>	<b>1</b>
<b>Frequency:</b>	<b>60 HZ</b>
<b>Full Load Amps:</b>	<b>15.1 amps</b>
<b>Plug configuration:</b>	<b>NEMA 5-20P</b>

**Cabinet Material:** 300 series stainless steel...400 series stainless and aluminized where appropriate.

**Controls:** Programmable digital controller with low temperature alarm.

**Heater System:** Electrical resistance 900 watt heaters with blower fan for circulation, located away from oils and vapors.

**Performance:** Temperature range to 210° F. Preheat to 160° F in 20 minutes.

*Specifications subject to change through product improvement and innovation.*

## UNPACKING AND INSPECTION



This appliance should be thoroughly cleaned prior to use.

See the **CLEANING INSTRUCTIONS**, on page 7 of this manual.

**NOTE: DO NOT** discard the carton or other packing materials until you have inspected the appliance for hidden damage and tested it for proper operation.

Refer to *SHIPPING DAMAGE CLAIM PROCEDURE* on bottom of this page.

1. Remove the cabinet from shipping carton, ensuring that all packing materials and protective plastic has been removed from the unit. Inspect all components for completeness and condition.
2. If any freight damage is present, a freight claim must be filed immediately with the shipping company.
3. **Freight damage is not covered under warranty.**
4. Check to insure all components are included: cabinet, instruction packet and additional accessories, such as product dividers.
5. Read operation instructions completely.
6. Connect power cord to grounded and properly wired electrical source as specified.
7. Appliance should be thoroughly cleaned before use. See **CLEANING INSTRUCTIONS**, page seven.

## FREIGHT DAMAGE PROCEDURE

**NOTE:** For your protection, please note that equipment in this shipment was carefully inspected and packaged by skilled personnel before leaving the factory. Upon acceptance of this shipment, the transportation company assumes full responsibility for its safe delivery.

### IF SHIPMENT ARRIVES DAMAGED:

1. **VISIBLE LOSS OR DAMAGE:** Be certain that any visible loss or damage is noted on the freight bill or express receipt, and that the note of loss or damage is signed by the delivery person.
2. **FILE CLAIM FOR DAMAGE IMMEDIATELY:** Regardless of the extent of damage. **Contact your dealer immediately.**
3. **CONCEALED DAMAGE:** If damage is unnoticed until the merchandise is unpacked, notify the transportation company or carrier immediately, and then file a "CONCEALED DAMAGE" claim with them. This should be done within fifteen (15) days from the date the delivery was made to you. **Be sure to retain the container for inspection.**

Pitco cannot assume liability for damage or loss incurred in transit, **freight damage is not covered under warranty.** We will, however, at your request, supply you with the necessary documents to support your claim.

## INSTALLATION & START-UP



### **WARNING:** Risk of personal injury

Installation procedures must be performed by a qualified technician with full knowledge of all applicable electrical codes.

Failure can result in personal injury and property damage.



### **IMPORTANT:** Power cord is 7' long.

If necessary, contact a licensed electrician to install an appropriate 20 amp electrical circuit with correct NEMA receptacle.



### **CAUTION:** Electrical Shock Hazard

The ground prong of the power cord is part of a system designed to protect you from electric shock in the event of internal damage.

DO NOT cut off the large round ground prong or twist a blade to fit an existing receptacle.



### **IMPORTANT:** Not under warranty:

Damage to unit due to being connected to the wrong voltage or phase is **NOT** covered by warranty.



### **CAUTION:** Risk of personal injury

Unit is not waterproof, to avoid electrical shock keep unit and counter from being submerged in water. Do not operate if unit has been submerged in water.

### **Location**

For proper operation and maximum performance, locate the Crisp n' Hold in an ambient air temperature of 70° F (21°C).

Avoid areas near exhaust fans where there is active air movement. For safe operation, locate the unit a reasonable distance from combustible walls and materials.

To prevent injury and damage, locate the unit at a proper and safe working height. The location should be level, clean of debris, and strong enough to support the weight of a fully loaded unit.

### **Start-up**

1. Plug the Crisp n' Hold into a properly grounded electrical receptacle.
2. Ensure all plastic and packaging materials have been removed.
3. Familiarize yourself with the controls.
4. On/Off switch is located inside the cabinet below the product station. Set POWER switch to "ON" position.
5. Do not load product into the cabinet. Allow the heat to remove any residual oils which may adhere to inside metal surfaces. A slight emission of smoke is normal for the first few hours of operation.



### **GROUNDING INSTRUCTIONS**

This appliance is equipped with a cord having a grounding wire with a grounding plug which must be plugged into an outlet that is properly installed and grounded. In the event of an electrical short circuit, grounding reduces the risk of electric shock by providing an escape wire for the electric current.

**WARNING—Improper use of the grounding can result in a risk of electric shock.** Consult a qualified electrician or serviceman if the grounding instructions are not completely understood, or if doubt exists as to whether the appliance is properly grounded.

## NORMAL OPERATION



### CAUTION: HOT SURFACE

Inner surfaces of the unit will be very hot during and after operation.

Avoid touching the cabinet when loading or removing product.

### Daily operating procedures

1. Prior to use, unit must be installed properly and tested by a trained installation or service professional.
2. Unit must be clean and grease-free prior to use.
3. Verify that the grease pan, heat duct and air filters are installed
4. Open door, locate switch to the right of the controller and turn power on. The motors should begin to turn and create airflow.
5. Unit will automatically begin to preheat, allow 20 minutes for unit to climb to operating temperature of 160° degrees F.
6. Load product into Crisp n' Hold.

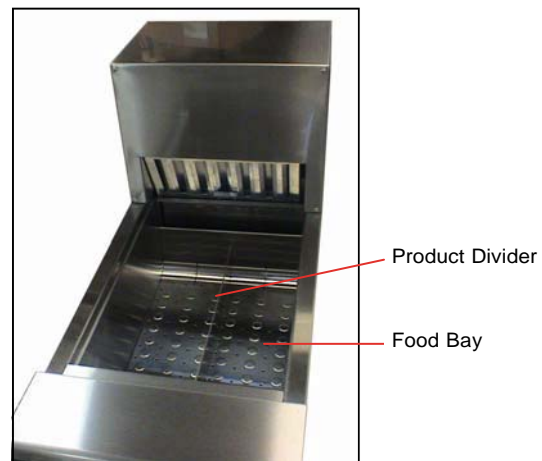

## CONTROLLER PROGRAMMING

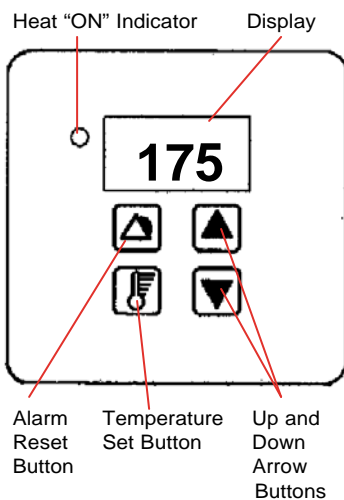

The controller has been factory pre-set at 175°F (79°C), and has a low temperature alarm pre-set for 140°F (60°C).

### To View or Change the Temperature Setpoints

Turn the power on. To view the temperature setpoint, press and hold the temperature set button. To change the temperature setpoint, press and hold the temperature set button; press the up or down arrow button until the desired air temperature is displayed. The display will advance in 1° increments.

### To View or Change Alarm Setpoints

Turn the power on. To view the alarm setpoint, press and hold the alarm reset button; press the up or down arrow button until the desired alarm temperature is displayed. The display will advance in 1° increments.

### To View or Change the Temperature Scale

The cabinet is programmable for a temperature scale in degrees Fahrenheit and Centigrade (Celsius). Turn power off. Hold down both arrow buttons and while holding both arrows, turn power back on. Display will show current scale (°C or °F). If desired, push the up or down arrow to change the scale.

## CLEANING PROCEDURES



### CAUTION: ELECTRIC SHOCK HAZARD

Disconnect appliance from electric power before cleaning.



### CAUTION: HOT SURFACE

Exposed surfaces can be hot to the touch and may cause burns. Allow appliance to cool before cleaning.

**IMPORTANT:** DO NOT spill or pour water into controls, control panel or wiring. Water damage is **not** covered by warranty.



### CAUTION:

Beware of sharp edges on sheet metal during cleaning, especially during removal of grease filters.



Food Bay

Removal of air filter

Grease/crumb pan

Product Divider



### CAUTION

Cleaners, detergents, degreasers, sanitizers, or bleaching agents that contain chlorides or phosphates will cause permanent damage to stainless steel products. The damage appears as pits, eruptions, voids, small holes, severe discoloration or dulling of the metal finish. Water with high chloride content can also damage stainless steel. If unsure of your water quality, we recommend you have it tested. **THIS DAMAGE IS PERMANENT, COSTLY TO REPAIR, AND IS NOT COVERED BY THE WARRANTY.**

### RECOMMENDED TIPS FOR CLEANING STAINLESS STEEL

<u>Purpose</u>	<u>Frequency</u>	<u>Cleaning Agent</u>	<u>Method of Application</u>
Routine cleaning	Daily	Soap, ammonia detergent and water	Sponge with cloth, rinse with clear water and wipe dry.
Smears/ Fingerprints	As needed	Stainless steel cleaner or similar products	Rub with soft cloth as directed on package. Rub in direction of grain of stainless steel. Do not use on vinyl trim.
Stubborn spots and stains	Daily as needed	Any chloride-free or phosphate-free cleaner	Apply with damp sponge or cloth. Rub in direction of grain of stainless steel. Rinse thoroughly, especially if cleaner contains chlorine bleach, do not use on vinyl trim.
Hard water spots	Daily as needed	Vinegar	Swab with cloth. Rinse with water and wipe dry.

## WIRING DIAGRAM

**PCF14 & PCF18**  
 1820 watts, 120v, 15.1A, 60Hz, 1 Ph, NEMA 5-20P

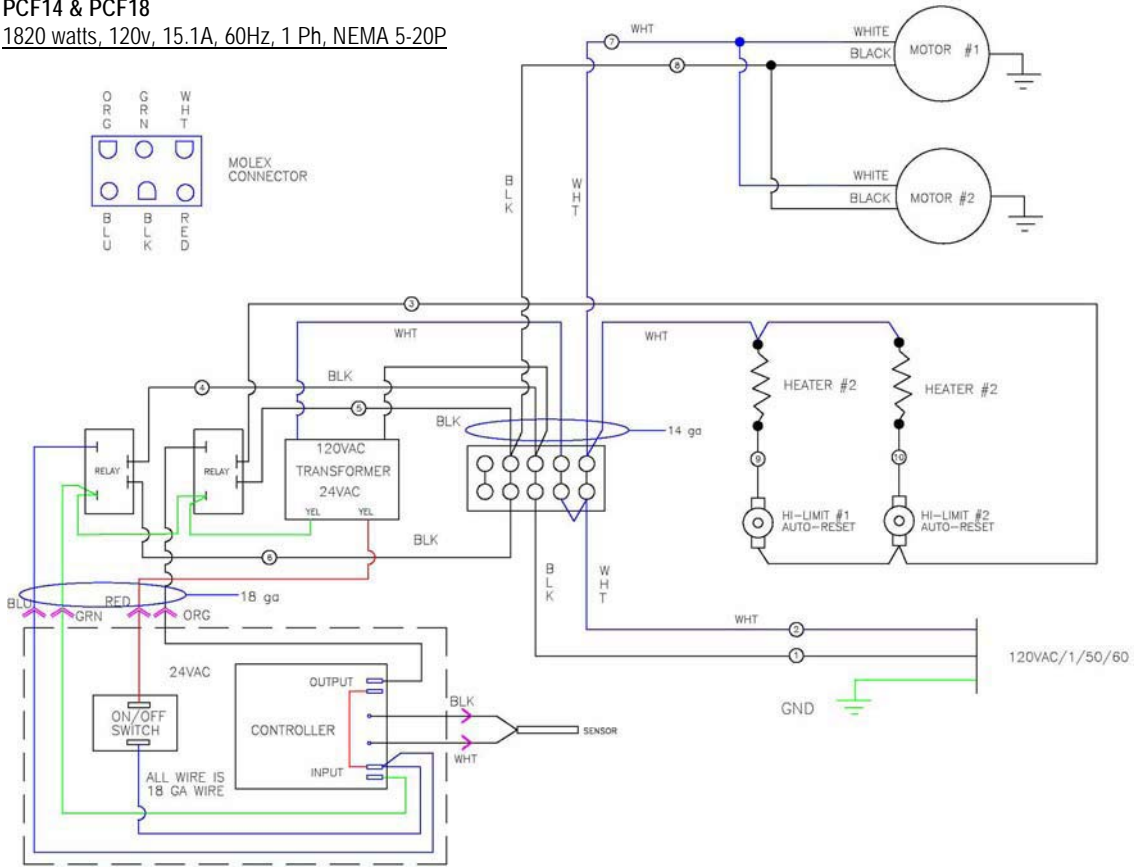

## REPLACEMENT PARTS

PART NUMBER	DESCRIPTION	PCF14 120V	PCF18 120V	PCF14 240V
18614-0362	MOTOR C-FRAME 120V CNH	X	X	
18614-0364	MOTOR C-FRAME 240V CNH			X
18614-0365	WHEEL,BLWR,3.125" CW ROT	X	X	X
18614-0359	INLET SCREEN 3.81"	X	X	X
18600-0061	THERMAL DISC AUTO RESET	X	X	X
18612-0113	TUBULAR ELEMENT 900W/120V	X	X	X
18616-0223	RELAY SPST-NO,240V,24VAC	X	X	X
18616-0229	CONTROL WGRN LGHT ROHS	X	X	X
18312-0189	CONTROL OVERLAY	X	X	X
18602-0172	ROCKER SW SPST ON/OFF	X	X	X
18616-0198	PROBE 3/16 X 1.5 X 18.5	X	X	X
18616-0135	TRNSFORMER B24-N0120-015	X	X	
18616-0131	CONTROL TRANFRMR NTI-2575			X
18602-0174	GREASE BAFFLE PCF14	X		X
18602-0175	GREASE BAFFLE PCF18		X	
18605-0018	14/3 HSJO CORD W/6-15PLUG			X
18605-0017	14/3 HSJO CORD W/5-20PLUG	X	X	

## TROUBLESHOOTING GUIDE

SYMPTOM	POSSIBLE CAUSE	SUGGESTED REMEDY
No power to unit	Not plugged in or circuit breaker tripped	Check or reset circuit breaker Connect to proper receptacle
	Power cord damaged	Check - replace if required
	Power switch damaged or defective	Check - replace if required
Food dries out too quickly	Operation where product temp is too high	Check product temps going into holding cabinet
	Thermostat incorrectly set or defective	Check proper operation or calibration of thermostat
Unit is on, motors are running but no heat	Internal wiring error	Call service technician
	Element hi-limit trip /defective	Call service technician
Takes too long to get to temperature	Improper voltage	Call service technician to verify incoming voltage matches cabinet specifications.
Unit is hot but low or no airflow	Internal wiring error	Call service technician
	Circulation motor has quit	Call service technician
	Improper voltage	Call service technician to verify incoming voltage matches cabinet specifications.

**NOTE:**

The technical content of this manual, including any wiring diagrams, schematics, parts breakdown illustrations and / or adjustment procedures, is **intended for use ONLY by qualified technical personnel.**

**NOTE:**

For warranty service, call Pitco direct at 800-258-3708 for authorization, we will dispatch the nearest authorized service agency.



## ***Pitco Warranty:***

Pitco Frialator, Inc. warrants to the original user of its commercial cooking equipment and related equipment that said appliances and related equipment will be free from defects in material and workmanship under normal use for a period of one (1) year from the date of installation, with appropriate documentation, to a maximum of fifteen (15) months from the date of manufacture, subject to the following additions, exceptions, exclusions & limitations.

This warranty is limited to the repair or replacement at the Company's option, without charge, of any part found to be defective within the warranty period and reasonable expenses incurred for freight and material for the installation of such part; in addition, the Company's obligation shall be limited to reimbursement for normal labor on such parts. Pitco Frialator, Inc. agrees to pay the Authorized Service and Parts Distributor for any labor and material required to repair or replace, at the Company's option, any part which may fail due to defects in material or workmanship during the above general warranty period.

### **How to Keep Your Warranty in Force**

- Make sure any shipping damages are reported immediately. Damages of this nature are the responsibility of the carrier.
- Install the unit properly. This is the responsibility of the installer and the procedures are outlined in the equipment manual.
- Do not install appliance in a home or residence.
- Maintain appliance properly. This is the responsibility of the user of the appliance and the procedures are outlined in the manual.
- Adjustments, such as calibration, leveling, tightening of fasteners or plumbing or electrical connections normally associated with initial installation, if necessary, are outlined in the manual.
- Damages due to flood, fire, or other acts of God, are not covered by the warranty.
- Use appliance only for its intended purpose. If it is used for a purpose other than for which it was intended or designed, any resulting damages are not covered under warranty.
- Do not materially alter or modify the appliance from the condition in which it left the factory.
- Do not obliterate, remove or alter the serial number rating plate.
- Use only genuine OEM parts from Pitco Frialator, Inc. or its Authorized Parts and Service Distributors. Repairs are not covered by the warranty.
- If any other failure occurs which is not attributable to a defect in materials or workmanship, it is not covered by the warranty.

This warranty specifically excludes parts which wear or would be replaced under normal usage, including, but not limited to, electric lamps, fuses, interior or exterior finishes and gaskets.

### **Limits to the Warranty**

Outside the United States and Canada, this warranty is limited to the replacement of parts and Pitco Frialator, Inc. will not bear any other expense be it labor, mileage, freight or travel. If any oral statements have been made regarding this appliance, these statements do not constitute warranties and are not part of the contract of sale. This limited warranty constitutes the complete, final and exclusive statement with regard to warranties. **THIS LIMITED WARRANTY IS EXCLUSIVE AND IS IN LIEU OF ALL OTHER WARRANTIES WHETHER WRITTEN, ORAL OR IMPLIED, INCLUDING, BUT NOT LIMITED TO, ANY WARRANTY OF MERCHANTABILITY OR FITNESS FOR A PARTICULAR PURPOSE OR WARRANTY AGAINST LATENT DEFECTS.**

### **Limitations of Liability**

In the event of a warranty or other claim, the sole obligation of Pitco Frialator, Inc. will be the repair or replacement, at the company's option, of the appliance or the component part. The repair or replacement will be at the expense of Pitco Frialator, Inc. except as limited by this warranty statement. Any repair or replacement under this warranty does not constitute an extension in time to the original warranty. Parts covered under this warranty will be repaired or replaced, at the Company's option, with new or functionally operative parts. The liability of Pitco Frialator, Inc. on any claim of any kind, including claims based on warranty, express or implied contract, negligence, strict liability or any other legal theories, will be exclusively the repair or replacement of the appliance. This liability will not include, and the purchaser specifically renounces any right to recover special, incidental, consequential or other damages of any kind, including but not limited to, injuries to persons, damage to property, loss of profits or anticipated loss of the use of this appliance. If any provision of this warranty is unenforceable under the law of any jurisdiction, only that provision will be inapplicable there, and the remainder of the warranty will remain unaffected. The maximum exclusion or limitation allowed by law will be substituted for the unenforceable provision.

### **How to Obtain Warranty Service**

First direct your claim to the Pitco Frialator, Inc. Authorized Service and Parts Distributor closest to you. Give the complete model, serial and code numbers, voltage, gas type, and description of the problem. Proof of the date of installation and/or the sales slip may also be required. If this procedure fails to be satisfactory, write to: The Service Manager, Pitco Frialator, Inc., PO Box 501, Concord, NH 03302-0501 USA.

This warranty gives you certain specific legal rights; you may have other rights which may vary from state to state.

## ***Pitco Frialator, Inc.***

**PO Box 501, Jct I-89 & I-93, Concord, NH 03302-0501  
509 Route 3S, Bow, NH 03304**

Phone: 603-225-6684 • Fax: 603-225-8497

Sales & Marketing E-mail: sales@pitco.com • Service E-mail: service@pitco.com

Company Website: www.pitco.com